

2009 STANDARD SPECIFICATIONS FOR HIGHWAY CONSTRUCTION

Adopted October 1, 2008

Volume 2 of 2



BRITISH
COLUMBIA

The Best Place on Earth

Ministry of
Transportation
and Infrastructure

2009 STANDARD SPECIFICATIONS
FOR
HIGHWAY CONSTRUCTION

VOLUME 2

**Adopted
October 1, 2008**

Construction and Maintenance Branch
Ministry of Transportation and Infrastructure

Canadian Cataloguing in Publication Data

British Columbia. Ministry of Transportation and
Infrastructure.

Standard specifications for highway construction
effective February 1, ...-- 1991 -

Annual.

ISSN 1188-0120 = Standard specifications for
highway construction (Victoria)

1. Roads - Specifications - British Columbia. I.
Title.

TE27.B7B74

625.7

C91-092305-1

NOTICE TO USERS

SECTIONS 101 to 586 - VOLUME ONE

SECTIONS 604 to 991 - VOLUME TWO

All text significantly changed or added since the 2006 edition is shown with single underlining and a vertical bar in the margin. Deletions and minor corrections such as typos have not been marked.

To obtain the Standard Specifications for Highway Construction Volume - 1 & 2 - 2009

- Order online at <http://www.publications.gov.bc.ca/> , click on general public go shopping button and in the “search” field type in 7680002870, the Queen’s Printer stock number, select the item and click the “add to shopping cart” button. You will require a Visa or MasterCard to process this order. (Visa and/or MasterCard information is stored on our secure server)
- Mail in a Company Cheque, Money Order or Certified Cheque payable to the Minister of Finance to:

Queen’s Printer,
Government Publication Services,
Box 9452, Stn Prov Govt
Victoria BC V8W 9V7
- Phone toll free 1 800 663-6105 or locally in Victoria at 387-6409, with your Visa or MasterCard Number and we will place the order for you.

To view the electronic version of these specifications go to:

http://www.th.gov.bc.ca/Publications/const_maint/contract_serv/standardspecs.htm

For technical content please contact:

Construction Contracts Engineer
Construction and Maintenance Branch
Ministry of Transportation
940 Blanshard Street Level 4C
PO Box 9850 STN PROV GOVT
Victoria BC V8W 9T5

Telephone: (250) 387-7752 or (250) 387-6931
Facsimile: (250) 356-7276

THIS PAGE IS LEFT INTENTIONALLY BLANK

SECTION TITLES

VOLUME ONE CONTAINS THE FOLLOWING SECTIONS:

SECTION 101 - QUALITY MANAGEMENT
SECTION 108 - SAMPLE FORMS
SECTION 125 - VALUE ENGINEERING - PROPOSAL GUIDELINES
SECTION 135 - CONSTRUCTION SITE SAFETY (**REVISED SECTION**)
SECTION 145 - GENERAL REQUIREMENTS FOR HIGHWAY, BRIDGE AND MARINE
CONSTRUCTION
SECTION 165 - PROTECTION OF THE ENVIRONMENT
SECTION 194 - TRAFFIC MANAGEMENT FOR WORK ZONES
SECTION 200 - CLEARING AND GRUBBING
SECTION 201 - ROADWAY AND DRAINAGE EXCAVATION
SECTION 202 - GRANULAR SURFACING, BASE AND SUB-BASES
SECTION 204 - ROCK CUTS
SECTION 205 - RIPRAP
SECTION 206 - ROCK BOLTS
SECTION 207 - SLOPE MESH FOR ROCK CUTS
SECTION 208 - DRAINS FOR ROCK CUTS
SECTION 209 - SHOTCRETE FOR ROCK CUTS
SECTION 211 - PORTLAND CEMENT CONCRETE
SECTION 213 - TIMBER BRIDGES - CONSTRUCTION
SECTION 214 - TIMBER PILING CONSTRUCTION
SECTION 215 - BRIDGES
SECTION 216 - COATING OF STEELWORK
SECTION 218 - CONCRETE FOR MINOR WORKS
SECTION 232 - METAL BIN-WALL
SECTION 303 - CULVERTS
SECTION 308 - COATING SYSTEMS (**REVISED SECTION**)
SECTION 312 - STEEL TRAFFIC BARRIERS AND WOOD POSTS
SECTION 316 - STEEL AND WIRE FENCE MATERIALS
SECTION 317 - P.E. PLASTIC DRAINAGE PIPE (**REVISED SECTION**)
SECTION 318 - PVC PLASTIC DRAINAGE PIPE
SECTION 320 - CORRUGATED STEEL PIPE
SECTION 321 - TRAFFIC PAINT
SECTION 407 - FOUNDATION EXCAVATION (**REVISED SECTION**)
SECTION 412 - CONCRETE REINFORCEMENT
SECTION 413 - BRIDGE DECKS AND CONCRETE OVERLAYS

- SECTION 415 - MANUFACTURE AND ERECTION OF PRECAST AND PRESTRESSED CONCRETE MEMBERS
- SECTION 416 - MANUFACTURE AND INSTALLATION OF POST-TENSIONED CONCRETE MEMBERS
- SECTION 418 - CONCRETE BRIDGE DECK SEALANTS - SILANE SURFACE TREATMENT OF NEW PORTLAND CEMENT CONCRETE
- SECTION 419 - CONCRETE BRIDGE DECK WATERPROOFING SYSTEM - PREFABRICATED MEMBRANE
- SECTION 421 - STRUCTURAL STEELWORK
- SECTION 422 - MISCELLANEOUS STEELWORK
- ~~SECTION 501 - HOT MIXED ASPHALT PAVEMENT (**DELETED**)~~
- SECTION 502 - ASPHALT PAVEMENT CONSTRUCTION (EPS) (**REVISED SECTION**)
- SECTION 503 - BASE PREPARATION AND BASE PROCESSING
- SECTION 504 - PAVEMENT DRAINAGE
- SECTION 507 - PRODUCTION AND STOCKPILING OF ASPHALT MIX
- SECTION 508 - GRADED AGGREGATE SEAL COAT (EPS)
- SECTION 511 - COLD MILLING
- SECTION 514 - HOT IN-PLACE RECYCLE
- SECTION 515 - HOT-IN-PLACE RECYCLED ASPHALT PAVEMENT (EPS)
- SECTION 521 - ASPHALT STABILIZED BASE COURSE MIXED IN PLACE
- SECTION 531 - ASPHALT SURFACE TREATMENTS
- SECTION 536 - PAVEMENT CRACK SEALING
- SECTION 541 - RUBBLE MASONRY
- SECTION 582 - CONCRETE CURB AND GUTTER AND STORM DRAINAGE
- SECTION 586 - PLANT MIXED PORTLAND CEMENT TREATED BASE COURSE

SECTION TITLES

VOLUME TWO CONTAINS THE FOLLOWING SECTIONS:

SECTION 604 - STEEL TRAFFIC BARRIER CONSTRUCTION
SECTION 635 - ELECTRICAL AND SIGNING
SECTION 700 - WILDLIFE EXCLUSION FENCING (**NEW SECTION**)
SECTION 741 - FENCE CONSTRUCTION
SECTION 751 - TOPSOIL AND LANDSCAPE GRADING
SECTION 754 - PLANTING OF TREES, SHRUBS, AND GROUND COVERS
SECTION 757 - REVEGETATION SEEDING
SECTION 766 - IRRIGATION
SECTION 769 - PROTECTION AND RETENTION OF VEGETATION
SECTION 903 - TIMBER - MATERIALS
SECTION 904 - TIMBER (TREATED AND UNTREATED) - FABRICATION AND HANDLING
SECTION 905 - TIMBER - GLUED LAMINATED
SECTION 906 - ROUND TIMBER PILES
SECTION 908 - PRESERVATIVE TREATMENT - WOOD PRODUCTS
SECTION 909 - TREATED WOOD FENCE POSTS
SECTION 911 - STEEL AND IRON
~~SECTION 913 - REINFORCEMENT FOR CONCRETE (**DELETED**)~~
SECTION 917 - WIRE ROPE
~~SECTION 931 - PORTLAND CEMENT (**DELETED**)~~
SECTION 933 - ADMIXTURES FOR PORTLAND CEMENT CONCRETE
SECTION 941 - PRECAST REINFORCED CONCRETE BARRIERS
SECTION 951 - ASPHALT AND PAVING MATERIALS FOR HIGHWAY USE
SECTION 952 - CONTRACTOR SUPPLY ASPHALT AND PAVING MATERIALS FOR
HIGHWAY USE
SECTION 971 - PLASTIC TRAFFIC CONES
SECTION 991 - CALCIUM CHLORIDE AND SODIUM CHLORIDE

THIS PAGE IS LEFT INTENTIONALLY BLANK

SECTION 604

STEEL TRAFFIC BARRIER CONSTRUCTION

604.01 Scope - This Section covers the construction of roadside and median steel traffic barriers in accordance with the general layout and details indicated on Drawings of the SP312 series.

Steel beam guardrail, wood posts and accessory materials are specified by SS 312.

Design and part number references are taken from the ARTBA Technical Bulletin #268-B, as noted in Section 312, unless indicated otherwise on Drawings 1-SP312 and 2-SP312.

604.02 Provision of Steel Barriers - Barriers of the type(s) called for shall be constructed at the locations and as shown on the Contract Drawings with the materials, accessories and necessary ancillary work all in accordance with the details indicated on the Contract Drawings, Specifications, Special Provisions and/or typical standard SP Drawings or to the direction of the Ministry Representative.

All materials will be supplied by the Contractor, unless the Special Provisions specify Ministry supply.

Construction shall be carried out with all labour, tools, equipment and incidentals necessary to complete all barrier work in accordance with good work practice, for a substantially supported and anchored steel barrier developing a continuous beam strength together with necessary crashworthy end treatment.

604.03 Materials - Detailed material requirements are set out in Section 312 and indicated on Drawings 1-SP312, 2-SP312 and the manufacturer's drawings.

Concrete for post footings shall be constructed of minimum 15 MPa Portland cement concrete in accordance with Section 218, and reinforcement, 152 x 152 MW18.2 welded steel wire fabric to CSA G30.5 and 10M deformed bar or minimum 7 mm stirrups in accordance with SS 412.

Preservative treatment for protecting field cuts and borings and for making good any superficial damage to treated wood post material, as approved by the Ministry Representative, shall be creosote, pentachlorophenol or preservative salts in proper solution corresponding to the original pressure treatment for application in three separate heavy coatings.

Touch-up treatment for damaged galvanized metal surfaces shall be a heavy application of zinc rich paint to CGSB Standard 1-GP-181M Specification for Ready Mixed Zinc Rich Coating.

604.04 Post Installation - Posts shall be set true to the lines, spacing, depth(s) and height(s) indicated or required. The layout, type of support and fixing treatment at ends of barriers or where adjacent to abutments and the like shall

be as indicated on the Contract Drawings and relevant Drawings 1-SP312 and 2-SP312, and/or to the direction of the Ministry Representative.

Wood posts shall be driven in place with equipment approved by the Ministry Representative or set in augered or dug holes with necessary dampened and well tamped layers of approved backfill material. Driving will be permitted only if no damage results to shoulders and adjacent slopes. In broken rock embankments the prepunching of holes will be permitted only prior to final compaction, surfacing and paving. Construction details appertaining on exposed rock, rock with minimum overburden or on concrete shall be to the indicated requirements and/or the direction of the Ministry Representative.

All work preparatory to and for the installation of posts shall be to the direction and prior approval of the Ministry Representative for each type of sub-surface condition to produce a thoroughly sound guardrail support system.

Surplus excavated material remaining after guardrail support installation shall be disposed of in a uniform manner within the right of way or cleared away, as directed by the Ministry Representative.

Tops of all posts shall be set a uniform $25 \text{ mm} \pm 5 \text{ mm}$ above the line of the beam's top edge and where necessary cut to line up.

Posts damaged by the driving operation or other damage from their handling and installation not acceptable to the Ministry Representative shall be replaced at the Contractor's expense.

The tops of all posts and offset blocks, all post bolt holes and bored holes in posts shall receive a heavy soaking coat of the specified preservative treatment on three succeeding days.

604.05 Steel Beam Erection - Beam sections will normally be supplied or required for joining at 3.81 m intervals.

All punching, cutting or welding shall be shop executed except for special details in unforeseen and exceptional cases and to the prior approval of the Ministry Representative.

Sections shall have full bearing one to another at laps with splicing bolts drawn tight to 100 N·m for a continuous beam effect. Where guardrail is on a curve, the beam sections shall make close contact over the whole splice area. Shop bent beams will normally be supplied or required for curvature radii under 45 m.

Beam sections shall be bolted to posts so that the edges and centre portion(s) of beams make full bearing with each

SECTION 604

offset block or where applicable with back-up plate, post or other support. Where posts are treated with waterborne preservative salts, the bolt holes shall be filled with heavy grease before bolt insertion for corrosion protection.

Bolts shall not extend more than 15 mm beyond the fixing nut when tightened, with any excess removed and the threads burred.

Washers shall be used only where indicated on the standard Drawings of the SP312 series.

604.06 End Assemblies - End assemblies shall be carried out strictly according to the manufacturer's specifications unless specifically directed otherwise by the Ministry Representative in writing as to approved alternative methods and the like.

Note the safety preference for:

- a) Continuing guardrail to shield the entire length of any hazard (as indicated on Drawing 1-SP312), bridge abutment and the like in place of a bolted connector (RE-8).
- b) Approach transitions stiffened by means of reduced post spacing and, where necessary, the use of Thrie-beam or nested twin W-beams.
- c) End assemblies to be NCHRP certified.

STEEL TRAFFIC BARRIER CONSTRUCTION

Note: the discontinuance of the flared (spade shaped) terminal section, especially at the approach ends of guardrails.

Footings for posts shall be constructed of specified concrete and reinforcement to the minimum sizes indicated on Drawing 2-SP312, neatly trowelled on top to weathering slope with bullnosed edge circular on plan.

604.07 Measurement and Payment - Measurement of steel traffic barriers will be by the linear metre from end to end of all rail sections along the line of the completed guardrail or centreline of any doubled median barrier and, unless otherwise specified, overall terminal assemblies.

Payment will be made for steel traffic barrier work at the contract unit price(s) for standard steel W-beam shoulder or median barrier guardrail supplied and/or installed complete in place or for Thrie-beam shoulder or median barrier guardrail supplied and/or installed complete in place.

The contract price(s) shall be accepted as full compensation for supply of all materials, labour, tools, equipment and incidental work to complete the required installation including bolting, transitions, curves, all excavation, backfilling, and surplus disposal.

SECTION 635

ELECTRICAL AND SIGNING

PART A – GENERAL

635.01 Scope – This Section covers the requirements for electrical and signing works. Temporary construction signing is covered in SS 194 – Traffic Control.

Ministry Electrical Maintenance will be undertaken by non-Ministry forces, referred to as the “Electrical Maintenance Contractor”. The Contractor will be required to coordinate the work with the Electrical Maintenance Contractor and the appropriate Ministry Manager, Electrical Services in the Regions.

The Contractor shall arrange the supply, installation and removal of temporary C-63 (Traffic Pattern Changed), C-64 (Signal Operation Changed Signs) and W-329 (New) tabs with Ministry Electrical Maintenance. The Electrical Maintenance Contractor will supply, install and remove these signs at no expense to the Contractor.

The Ministry will designate a “Ministry Electrical Representative” to deal with the Contractor on electrical issues arising out of work under this Section.

635.02 Work Regulations – All electrical work shall comply with the latest edition of the Canadian Electrical Code. In addition, any applicable bulletins published by the Province of British Columbia shall apply.

The Contractor shall also conform to all applicable regulations of the Workers' Compensation Board and if required, submit a Notice of Project Form 52E49 before commencing a Ministry project. The Contractor shall ensure compliance with the following sections:

- a) A Workers' Compensation Board Form 30M33 must be completed prior to working in the vicinity of overhead power lines.
- b) Notice of Construction Projects, Workers' Compensation Board Occupational Health and Safety Regulation, Section 20.2.

635.03 Electrical Permits & Inspections – All electrical work shall be performed by a Registered Electrical Contractor under the provisions of the Electrical Safety Act. The Registered Electrical Contractor shall appoint at least one Registered Representative whose qualifications shall comply with the provisions of the Electrical Safety Act. The Contractor shall provide the Ministry Electrical Representative with the name and phone number of the Registered Representative prior to starting construction.

Prior to construction the Contractor shall obtain and pay for all permits required under the provisions of the Electrical Safety Act. The Contractor shall submit a copy of all permits to the Ministry Electrical Representative prior to starting construction.

Upon completion of an installation and prior to energization, the Contractor shall advise the Ministry Electrical Maintenance Contractor, the Engineer of Record and the Ministry Manager, Electrical Services that the work is complete and ready for final inspection. The Ministry Electrical Maintenance Contractor will inspect the installation and report deficiencies to the Ministry Manager, Electrical Services. The Ministry Manager, Electrical Services will in turn advise the Contractor of the deficiencies. The Engineer of Record may also undertake a review of the installation for conformance to the design where specifically noted in the Special Provisions. The Engineer of Record will report comments to the Ministry Manager, Electrical Services.

Once the items identified have been completed and corrected the Contractor will advise the Ministry Manager, Electrical Services who will undertake a final check and will advise if acceptable. If acceptable “notification of completion” will be issued by the Ministry Manager, Electrical Services. If not corrections will be required by the Contractor.

The Ministry will not accept the installation until all work has been approved by the British Columbia Safety Authority, and the Ministry Manager, Electrical Services.

635.04 Electrical Energy Supply – The electrical energy will be supplied from overhead lines of the utility company's secondary distribution system unless otherwise noted on the Drawings.

The Contractor shall be responsible for making the necessary arrangements with the utility company for the connection of new service(s) and, if required, the disconnection of existing service(s). The Ministry will pay all utility connection costs.

635.05 Materials – The Contractor shall supply all materials necessary for the satisfactory completion of the project other than those materials listed in the Special Provisions as supplied by the Ministry. All materials shall be new and conform to the requirements of the Drawings, other Subsections of the Specifications, and the *Electrical and Signing Material Standards Manual*.

The *Electrical and Signing Material Standards Manual* may be purchased from:

Government of British Columbia

Ministry of Management Services

Publication Index Website:

<http://www.publications.gov.bc.ca/>

(Go Shopping)

(Keywords: *Electrical and Signing Material Standards Manual*)

email: QPPublications@gov.bc.ca

Phone: (250)387-6409 or 1-800-663-6105

Fax: (250)387-1120

Address: PO BOX 9452 STN PROV GOVT
VICTORIA BC V8W 9V7

The Electrical and Signing Material Standards is available electronically on the Ministry of Transportation web at

http://www.th.gov.bc.ca/publications/eng_publications/electrical/electrical_and_traffic_eng/2003_material_standards/2003_material_standards.htm

All products contained in the Electrical and Signing Material Standards shall be supplied from the Ministry's *Recognized Products Book*. This list identifies the manufacturer, the approved product, the product model number and the product approval date. This list can be viewed via the Ministry web page at:

http://www.th.gov.bc.ca/publications/eng_publications/geotech/rpb.htm

This list will be updated periodically as products become pre-approved.

All electrical materials shall conform to all applicable CSA Standards and shall meet the approval of the British Columbia Safety Authority Inspector.

Unless noted otherwise, all permanent signs shall meet current Ministry specifications. The Ministry *Specifications for Standard Highway Sign Materials, Fabrication and Supply* are located on our Ministry web page at:

http://www.th.gov.bc.ca/publications/eng_publications/signs/Sign_Fabrication_Specs.pdf

Where alternative materials are permitted, approval must be received from the Ministry Electrical Representative prior to their use.

635.06 Utilities – Existing utilities are generally not shown on the electrical and signing Drawings. Where utilities are shown on the Drawings, their locations are approximate.

The Contractor shall locate and protect all existing utilities such as power lines, fibre optic cables, telephone lines, gas and oil pipelines, sewers, water works, etc. The Contractor shall at all times conduct its operations in accordance with the requirements of the utility authorities having jurisdiction. In the event of any damage to utilities, the Contractor shall be held responsible for the cost of all necessary repairs and restoration to the satisfaction of the Ministry Electrical Representative and Utility Authority.

All costs for locating and protecting utilities will be considered incidental to the Work.

PART B – UNDERGROUND

635.07 Concrete Bases – Concrete bases shall be constructed in accordance with Drawings SP635-1.1.1 through SP635-1.1.43 and SP635-1.4.1 through SP635-1.4.5. The use of the term "concrete bases" in SS 635 shall also mean "concrete spread footings" where applicable.

The Drawings make reference to concrete bases that are poured in place or precast. Poured-in-place bases shall be constructed in the excavation whereas precast bases shall be constructed outside the excavation (e.g., at a precast plant or precast on site by the Contractor). The Contractor has the option to use either precast or poured-in-place bases.

Supply and installation of concrete bases shall include the following:

- excavation and backfill;
- supply and installation of concrete and formwork;
- supply and installation of reinforcing steel;
- supply and installation of conduit;
- supply and installation of steel tubing sleeves in sign post bases; and
- installation of anchor bolts.

For poured-in-place bases, the Contractor shall notify the Ministry Electrical Representative prior to pouring concrete.

The Contractor shall check for conflicts with overhead lines prior to excavating for concrete bases. If it appears there may be an overhead conflict, the Contractor shall contact the Ministry Electrical Representative for further instructions. If the Contractor installs a concrete base in a location where the pole conflicts with overhead power lines, the Contractor shall remove the pole and relocate the concrete base to a location approved by the Ministry Electrical Representative. The Contractor shall pay all costs for pole and base relocation.

635.07.01 Excavation and Backfill – Excavations shall meet the requirements, but not the Quantities and Payment provisions of SS 407 – Foundation Excavation.

All excavation work shall be carried out as required to suit concrete bases. Where directed by the Ministry Electrical Representative, excavations shall be shored to avoid the cutting of pavement, sidewalks, and curb and gutter.

Base excavations shall be backfilled using the excavated material provided it consists of clean well graded granular soil having a maximum fines content of 8% (silt and clay size particles) and a maximum aggregate size of 100 mm. Where backfill material does not conform as noted above, base excavation shall be backfilled with 25 mm Well Graded Base Course Aggregate material as specified in SS 635.14. Unacceptable materials shall be disposed of as specified in SS 635.15.

Backfill shall be placed in layers not exceeding 150 mm compacted thickness and shall be compacted to a minimum 100% of the laboratory density obtained by the current ASTM test method D 698. Layer thickness shall be reduced and moisture content of the material adjusted as required to achieve compaction. Care shall be taken not to damage conduits.

All excavated and backfilled areas shall be restored to their original condition.

Asphalt restoration shall be performed in accordance with SSS 635.12.

Concrete curb and gutter restoration shall be performed in accordance with SS 635.13.

635.07.02 Concrete and Formwork – Concrete construction, including formwork, shall meet the requirements, but not the payment provisions of SS 211 – Portland Cement Concrete.

Proportioning of the concrete mixes shall be the responsibility of the Contractor. The Contractor shall notify the Ministry Electrical Representative 48 hours prior to pouring concrete for poured-in-place bases.

The concrete mix shall meet the specifications listed in Table 635-A.

TABLE 635-A CONCRETE MIX

Minimum compressive strength at 28 days	30 MPa
Maximum nominal aggregate size	28 mm
Maximum W/C ratio by mass	0.45
Air content	5 ± 1%
Slump	50 ± 20 mm

Concrete shall be vibrated in accordance with SS 211 – Portland Cement Concrete.

All exposed concrete surfaces shall be given a Class 3 finish and all buried surfaces a Class 1 finish in accordance with SS 211.17.

When supplying poured-in-place concrete bases, the Contractor shall have the concrete strength verified, using concrete test cylinders, prior to installing the structure onto the base. Contrary to SS 211 the minimum number of concrete strength tests shall be one each week per mix design or concrete supplier. The Contractor shall take concrete test cylinders at the location of the pour and perform tests in accordance with SS 211.09.01. The Contractor must provide written confirmation of concrete test cylinder results prior to installing any structure on the bases.

Where installations are of a fast-track nature, the Contractor shall use a stronger concrete mix that will give the equivalent 28 day strength.

All concrete bases shall have their concrete strength verified with the exception of controller bases, sign post bases and post mounted flasher bases. Pre-cast concrete bases constructed off-site shall have their strength verified only where specifically requested by the Ministry Electrical Representative or the Ministry Manager, Electrical Services.

The top finished surface of a concrete base shall not vary by more than 3 mm in depth as measured across the widest surface. If this variation exceeds 3 mm then the top 50 mm of the base shall be broken off by hand and reformed or the base shall be replaced as directed by the Ministry Electrical Representative.

635.07.03 Reinforcing Steel – Reinforcing steel shall meet the requirements but not the payment provisions of SS 412 – Reinforcing Steel.

All reinforcing steel shall conform to CAN/CSA-G30.18-M 400R.

The Contractor shall adjust the spacing of reinforcing steel to suit anchor bolts and conduit.

635.07.04 Anchor Bolts and Conduit – Anchor bolts and conduits shall be cast into the concrete bases.

Where an anchor bolt is damaged it shall be repaired in accordance with Drawings SP635-1.1.42 and 1.1.43.

Welding of anchor bolts shall not be permitted.

635.07.05 Steel Pipe Sleeves – Steel pipe sleeves shall be cast into the concrete bases. The type of sleeve shall be as noted on the Drawings and shall be in accordance with SS 635.28 or SS 35.29

635.07.06 Payment – Payment for CONCRETE BASES will be at the Contract Unit Price per base.

The Unit Price shall include all costs of types B, C, and D excavation, other than concrete and asphalt removal; supply and installation of shoring to meet WCB requirements, formwork, concrete, reinforcing steel and conduit; supply and installation of grout and sand to fill knock-out voids in controller bases and concrete pads in front of controller bases; supply and installation of steel sleeves in sign post bases; installation of individual anchor bolts or anchor bolts in cages; placing and compaction of excavated material as backfill; removal and disposal of excess excavated material; and all other labour, equipment, and materials necessary to complete the installation.

Any additional costs for supplying higher strength concrete shall be borne by the Contractor.

Payment for excavation of Type A material (solid rock) will be made on a Force Account Basis unless otherwise noted.

Shoring of excavations, as directed by the Ministry Electrical Representative, will be paid by Force Account unless otherwise noted. All costs related to shoring of

excavations required to meet WCB regulations will be borne by the Contractor.

De-watering of excavations will be paid by Force Account.

Where excavated material is ruled unacceptable for backfill, payment for 25 mm Well Graded Base Course Aggregate will be made under SS 635.14.01.

635.08 Junction Boxes and Vaults – Plastic junction boxes shall be installed in accordance with Drawings SP635-1.2.1 through SP635-1.2.16 and SP635-1.4.1 through SP635-1.4.3.

Concrete junction boxes shall be supplied and installed in accordance with Drawings SP635-1.3.1, 1.3.2, and 1.3.4.

Concrete vaults shall be supplied and installed in accordance with Drawings SP635-1.3.3 and 1.3.4.

Concrete Junction Boxes shall be designed to withstand 5000 kg static loading.

Concrete vaults shall be designed to withstand CS600 (H-20) Static Loading.

The Ministry-approved concrete junction box and vault suppliers are listed on Drawings SP635-1.3.1 and 1.3.3. Concrete junction box or vault suppliers wishing to seek Ministry approval must submit shop drawings sealed by a Structural Engineer (registered with the APEGBC) to the Ministry of Transportation – Engineering Branch, Victoria, verifying that their junction box or vault meets the loading requirements. The junction box or vault shall also meet the size and functional characteristics shown on the Drawings.

Excavations for junction boxes and vaults shall meet the requirements but not the Quantities and Payment provisions of SS 407 – Foundation Excavation.

All excavation work shall be carried out as required to suit junction boxes and vaults. Where directed by the Ministry Electrical Representative, excavations shall be shored to avoid the cutting of pavement, sidewalks and curb and gutter.

Junction boxes and vaults shall be installed on a bedding of 25 mm Well Graded Base Course Aggregate material in accordance with SS 202 – Granular Surfacing, Base and Sub-bases.

Junction box or vault excavations shall be backfilled using the excavated material except where excavated material is ruled unacceptable by the Ministry Electrical Representative. Where new material is required, 25 mm Well Graded Base Course Aggregate material shall be used as specified in SS 635.14. Unacceptable materials shall be disposed of as specified in SS 635.15.

Bedding and backfill material shall be placed in layers not exceeding 150 mm compacted thickness and shall be compacted to a minimum 95% of the laboratory density obtained by the current ASTM test method D 698. Layer

thickness shall be reduced and moisture content of the material adjusted as required to achieve compaction. Care shall be taken not to damage conduits.

The top of junction boxes and vaults shall be installed so that they are flush with the finished grade.

Concrete for junction box collars shall conform to SS 635.07.02.

All areas where excavation and backfilling have been performed shall be restored to their original condition.

Asphalt restoration shall be performed in accordance with SS 635.12.

Concrete curb and gutter restoration shall be performed in accordance with SS 635.13.

Lid hold down bolts shall be coated with anti-seize lubricant.

635.08.01 Payment – Payment for PLASTIC JUNCTION BOXES will be at the Contract Unit Price per junction box.

The Unit Price shall include all costs of types B, C, and D excavation, other than concrete and asphalt removal; installation of junction box sections, lids, drain plates, adapter plates and braces; supply and installation of shoring to meet WCB requirements, conductor support bars in boxes, concrete collars, 25 mm Well Graded Base Course Aggregate material below the junction box; placing and compaction of excavated material as backfill; removal and disposal of excess excavated material; and all other labour, equipment and materials necessary to complete the installation.

Payment for the excavation of Type A material (solid rock) will be made on a Force Account Basis unless otherwise noted.

Shoring of excavations, as directed by the Ministry Electrical Representative, will be paid by Force Account unless otherwise noted. All costs related to shoring of excavations required to meet WCB regulations shall be borne by the Contractor.

De-watering of excavations will be paid by Force Account.

Where excavated material is ruled unacceptable for backfill, payment for 25 mm Well Graded Base Course Aggregate will be made under SS 635.14.01.

Additional drainage in junction boxes, as required by the Ministry Electrical Representative, will be paid by Force Account.

635.08.02 Payment – Payment for CONCRETE JUNCTION BOXES AND VAULTS will be at the Contract Unit Price per junction box or vault.

The Unit Price shall include all costs of types B, C, and D excavation, other than concrete and asphalt removal; supply and installation of the concrete junction box or

vault complete with collar and lid; supply and installation of conductor supports; supply and installation of 25 mm Well Graded Base Course Aggregate material below concrete junction box or the vault; placing and compaction of excavated material as backfill; removal and disposal of excess excavated material; and all other labour, equipment and materials necessary to complete the installation.

Payment for the excavation of Type A material (solid rock) will be made on a Force Account Basis unless otherwise noted.

Shoring of excavations, as directed by the Ministry Electrical Representative, will be paid by Force Account unless otherwise noted. All costs related to shoring of excavations required to meet WCB regulations shall be borne by the Contractor.

De-watering of excavations will be paid by Force Account.

Where excavated material is ruled unacceptable for backfill, payment for 25 mm Well Graded Base Course Aggregate will be made under SS 635.14.01.

Additional drainage in vaults as required by the Ministry Electrical Representative will be paid by Force Account.

635.09 Conduits – All electrical conduits shall be installed in accordance with the Drawings.

Rigid PVC (RPVC) conduit shall be unplasticized polyvinyl chloride and conform to CSA C22.2 No. 211.2. Couplings, adapters, bends and fittings shall be unplasticized polyvinyl chloride and conform to CSA C22.2 No. 85. RPVC conduit shall be installed using CSA certified cement. Each standard length of RPVC conduit and fitting shall bear a certification mark to the applicable CSA standard.

Rigid metal conduit (RMC) shall be hot-dipped galvanized rigid steel and conform to CSA C22.2 No. 45. Any exposed metal on conduit shall be coated with cold galvanizing compound in accordance with SS 635.23.

Flexible liquid-tight non-metallic conduit (FC) shall conform to CSA 22.2 No. 227.2. All joints shall be made with FC threaded couplers, adapters or conduit fittings.

Liquid-tight flexible metal conduit (FMC) shall conform to CSA 22.2 No. 56. All joints shall be made with FMC threaded couplers, adapters or conduit fittings.

Conduit straps shall be galvanized steel single hole or double hole type (sized to suit conduit).

All empty conduits shall have a pull string and shall be capped in accordance with Drawings SP635-1.2.16 and 1.3.4. Pull string shall be polypropylene with a minimum tensile strength of 1.1 kN.

The Contractor shall lay out conduit so that 90° bends are avoided. Where 90° bend cannot be avoided, only one will be allowed for each conduit run.

Conduit couplings or bell ends damaged when pulling

conductors shall be rejected and replaced at the Contractor's expense. An appropriate pulling jig or method shall be used to avoid damaging conduit or fittings when pulling conductors.

635.09.01 Payment – Payment for CONDUIT will be at the Contract Unit Price per metre.

The Unit Price shall include all costs for the supply and installation of underground conduit, fittings, cement and pull strings; and all other labour, equipment and materials necessary to complete the installation.

Payment for conduits installed above ground on poles or sign structures is not included in this Subsection.

635.10 Trenching and Backfilling for Conduit –

Trenching and backfilling shall be performed in accordance with Drawings SP635-1.5.1, 1.5.2, 1.6.1, 1.6.2 and 1.7.1.

RPVC conduits shall be installed in an open trench in accordance with Drawings SP635-1.5.1, 1.5.2, 1.6.1, 1.6.2 and 1.7.1 except where conduits are to be drilled or pushed under the surface as specified in SS 635.11.

Trenches shall be excavated with neat, uniform sides to the minimum width necessary, but not less than the minimum dimensions indicated on Drawings SP635-1.5.1 and 1.5.2 (care shall be taken to prevent sloughing). Material in the floor of the trench shall be undisturbed, or if disturbed shall be re-compacted to the requirement herein for backfill.

Trenches shall be backfilled using the excavated material except where excavated material is ruled unacceptable for backfill. Where new material is required, 25 mm Well Graded Base Course Aggregate material shall be used as specified in SS 635.14. Unacceptable materials shall be disposed of as specified in SS 635.15.

A 150 mm wide yellow plastic marker tape indicating "WARNING ELECTRICAL" shall be installed in each trench for the complete length of the trench. The location of the marker tape shall be as shown on Drawings SP635-1.5.1 and 1.5.2.

Bedding and backfill material shall be placed in layers not exceeding 150 mm compacted thickness and shall be compacted to a minimum 100% (for road crossings) and 95% (for shoulder trenches) of the laboratory density obtained by the current ASTM test method D 698. Layer thickness shall be reduced and moisture content of the material adjusted as required to achieve compaction. Care shall be taken not to damage conduits.

All areas where trenching and backfilling have been performed shall be restored to their original condition.

Asphalt restoration shall be performed in accordance with SS 635.12.

Concrete curb and gutter and sidewalk restoration shall be performed in accordance with SS 635.13.

635.10.01 Payment – Payment for TRENCHING AND BACKFILLING FOR CONDUIT will be at the Contract Unit Price per metre.

The Unit Price shall include all costs of Types B, C and D excavation, other than concrete and asphalt removal; placing and compaction of excavated material as backfill; dewatering; supply and installation of trench marker tape; removal and disposal of excess excavated material; and all other labour, equipment and materials necessary to complete the installation.

Payment for excavation of Type A material (solid rock) will be made on a Force Account Basis.

Where excavated material is ruled unacceptable for backfill, payment for 25 mm Well Graded Base Course Aggregate will be made under SS 635.14.01.

635.11 Trenchless Conduit Installation – Where noted on the Drawings the Contractor shall install the conduit using a suitable trenchless technology to avoid cutting the existing pavement or sidewalk.

The trenchless technology selected shall suit the site conditions.

The Contractor shall give the Ministry Electrical Representative a minimum of 48 hours notice prior to installing conduits.

The Contractor shall locate all underground utilities prior to installing conduits.

635.11.01 Payment – Payment for installing conduit using trenchless technology will be at the Contract Unit Price per metre.

The Unit Price shall include all costs of excavation for set up; backfilling and restoration when finished, and all other labour, equipment and materials necessary to complete the installation.

No separate payment will be made for unsuccessful installation.

Payment for the supply and installation of conduit is covered under SS 635.09.01.

635.12 Asphalt Pavement – Asphalt paving shall be performed in accordance with SS 502 – Hot Mixed Asphalt Pavement (EPS).

Asphalt patching of conduit trenches shall be performed in accordance with Drawing SP635-1.5.1. Asphalt patching of excavations for junction boxes, vaults and bases shall be performed similar to the details shown on Drawing SP635-1.5.1.

Contrary to the requirements of Section 502, Asphalt placing by a paving machine will not be required. Asphalt pavement restoration shall be Class 1 medium mix installed in three 50 mm lifts unless otherwise noted or directed by the Ministry Electrical Representative.

The Contractor shall use a pavement saw to cut pavement

and shall exercise care to obtain a neat, uniform excavation line along the edge of the pavement. The Contractor shall also prevent the existing base gravel from sloughing and undermining the pavement.

Where three lifts of asphalt pavement are being placed to reinstate a trench, the first two lifts shall be compacted with vibratory equipment capable of operating within the excavated area and of compacting over the whole of it. The third lift shall be compacted with rolling equipment to produce a uniform surface matching the adjacent existing pavement.

635.12.01 Payment – Payment for ASPHALT PAVEMENT for electrical and signing work will be as follows:

- Where the electrical work forms part of a paving or road construction Project, measurement and payment will be made in accordance with Section 502 – Hot Mixed Asphalt Pavement.

- Where the electrical work does not form part of a paving or road construction Project, payment shall be made in accordance with Section 502 – Hot Mixed Asphalt Pavement, except that:

a) (not used)

b) No separate payment shall be made for spray primer and tack coat and all costs of this work shall be included.

c) Measurement for payment for conduit trenches shall be made in cubic meters of mix compacted in place, and shall be calculated using a 450 mm wide trench plus 300 mm (asphalt is excavated 150 mm beyond the trench on both sides as noted on Drawing SP635-1.5.1).

d) Measurement for payment for installation of all other works shall be made in cubic metres of mix compacted in place and shall be calculated from measurements of the work.

635.12.02 Payment – Payment for REMOVAL OF ASPHALT will be made at the Contract Unit Price per cubic metre.

The Unit Price shall include all costs of cutting, removing and disposing of existing asphalt; and all other labour, equipment and materials necessary to complete the removal of asphalt.

The volume for payment of asphalt removal for conduit trenches will be calculated by the actual volume of asphalt removed within a 450 mm wide trench plus 300 mm (asphalt is excavated 150 mm beyond the trench on both sides as noted on Drawing SP635.1.5.1).

The volume for payment of asphalt removal for all other work will be calculated from measurements of the work.

635.13 Concrete Curbs and Sidewalks – All concrete curbs and sidewalks shall be installed in accordance with SS 582 – Concrete Curb and Gutter and Storm Drainage.

Concrete shall meet the requirements of Note 1 on Drawing SP582-01.01.

The Contractor shall use a pavement saw to cut existing concrete unless otherwise directed by the Ministry Electrical Representative, and shall obtain a neat, uniform cut along the edge of concrete. The Contractor shall also prevent base gravel from sloughing and undermining the concrete.

635.13.01 Payment – Payment for CONCRETE CURBS will be at the Contract Unit Price in accordance with SS 582 – Concrete Curb and Gutter and Storm Drainage.

The Unit Price shall include all costs of excavation, other than concrete and asphalt removal; supply and installation of 25 mm Well Graded Base Course Aggregate bedding material; supply and installation of formwork, concrete and expansion joint material; removal and disposal of excess excavated material; and all other labour, equipment and materials necessary to complete the installation.

635.13.02 Payment – Payment for SIDEWALKS will be at the Contract Unit Price per cubic metre.

The Unit Price shall include all costs of excavation, other than concrete and asphalt removal; supply and installation of 25 mm Well Graded Base Course Aggregate bedding material; supply and installation of formwork, concrete and expansion joint material; removal and disposal of excess excavated material; and all other labour, equipment and materials necessary to complete the installation.

635.13.03 Payment – Payment for REMOVAL OF CONCRETE will be at the Contract Unit Price per cubic metre.

The Unit Price shall include all costs for the cutting, removing and disposing of existing concrete roadway, sidewalk, etc.; and all other labour, equipment and materials necessary to complete the removal of concrete.

The volume for payment of concrete removal for conduit trenches will be calculated by the actual volume of concrete removed within a 450 mm wide trench.

The volume for payment of concrete removal for all other work will be calculated from measurements of the work.

635.13.04 Payment – Payment for REMOVAL OF CONCRETE CURBS will be at the Contract Unit Price per metre.

The Unit Price shall include all costs for cutting, removing and disposing of existing concrete; and all other labour, equipment and materials necessary to complete the removal of concrete curbs.

635.14 25 mm Well Graded Base Course Aggregate – 25 mm Well Graded Base Course Aggregate shall meet the requirements of SS 202 – Granular Surfacing, Base and Sub-bases.

When acceptable excavated material is not available, 25 mm Well Graded Base Course Aggregate shall be used

as backfill. It shall also be used for additional backfill around bases, junction boxes, vaults, median island fill and other work as required by the Ministry Electrical Representative.

635.14.01 Payment – Payment for 25 mm WELL GRADED BASE COURSE AGGREGATE will be at the Contract Unit Price per cubic metre.

The Unit Price shall include all costs of the supply, hauling, placing, trimming and compacting the material, and all other labour and equipment necessary to complete the installation.

Where the 25 mm Well Graded Base Course Aggregate material is used to backfill a conduit trench, its volume shall be calculated in place using:

- a) The actual length of trench from which the material is designated unacceptable;
- b) a 450 mm wide trench; and
- c) the actual depth of this material compacted in place.

Where 25 mm Well Graded Base Course Aggregate material is used to backfill bases, junction boxes, vaults, or other work the volume will be calculated by the actual compacted volume of material installed in the excavation less the volume of the item installed in the excavation.

635.15 Removal of Rejected Excavated Material – Where excavated material is designated unacceptable for backfill by the Ministry Electrical Representative it shall be removed from the work site and disposed of by the Contractor.

The disposal site shall be approved by the Ministry Electrical Representative.

635.15.01 Payment – Payment for the REMOVAL OF REJECTED EXCAVATED MATERIAL will be at the Contract Unit Price per cubic metre.

The Unit Price shall include all costs of removal and disposal, and all other labour, equipment and materials necessary to complete the removal of rejected material.

Where the rejected material has been excavated from a conduit trench, its volume shall be calculated in place using:

- a) The actual length of trench from which the material is designated unacceptable;
- b) a 450 mm wide trench; and
- c) the actual depth of material removed.

Where the rejected material has been excavated for bases, junction boxes, vaults or other work the volume will be calculated by the actual volume of excavated material less the volume of the item installed in the excavation.

635.16 Restoration – Areas where work has been performed shall be returned to their original condition and must be left in a neat state to the satisfaction of the

Ministry Representative. All costs for restoration will be considered incidental to the Work.

PART C – ELECTRICAL

635.17 Luminaire, Signal and Sign Poles – Luminaire and signal poles shall be installed in accordance with Drawings SP635-2.1.1 through SP635-2.1.14, and SP635-2.2.1 through SP635-2.2.10.

Where specified, luminaire poles shall be mounted on frangible or breakaway bases in accordance with Drawings SP635-2.1.15 and 2.1.16.

Sign poles shall be installed in accordance with Drawings SP635-3.1.1 through SP635-3.1.22.

Poles shall not be erected until concrete bases have attained a strength of 30 MPa.

Push button and signal head locations shall be verified before poles are drilled and assembled.

Field drilling of holes larger than 33 mm (1 5/16") diameter will not be permitted in Type 1, 3, 6, 7, L, M and H shafts, and all arms and extensions. Where larger holes are required, the holes shall be reinforced with a welded bushing in accordance with Drawing SP635-2.4.13.

All components of the luminaire, signal and sign poles shall be handled with care to prevent stress to the components through bending or twisting. A nylon sling shall be used to transport and erect the components. The use of steel chains as slings will not be permitted. Any damage to the components through overstress, scratching or denting shall be repaired or replaced at the Contractor's expense to the satisfaction of the Ministry Electrical Representative.

All pole shafts shall be installed plumb. Where possible, all luminaire poles shall be positioned with the handhole oriented opposite the road and if not possible, on the downstream traffic side.

All wiring inside the poles shall be in accordance with SS 635.19.

Pole shafts shall mount directly on concrete bases and, where necessary, shall be trued to plumb using levelling shims.

The Contractor shall tighten all bolts and nuts to 1/3 rotation past snug tight. "Snug-tight" is the tightness attained by a few impacts of an impact wrench or the full effort of a person using a spud wrench.

All scratches in poles and all field drilled holes shall be coated with cold galvanizing compound as per SS 635.23.

Hand hole bolts shall be coated with anti-seize lubricant.

635.17.01 Traffic and Pedestrian Signal Heads – Traffic and pedestrian signal heads shall be installed in accordance with Drawings SP635-2.3.1 through SP635-2.3.6 and -2.3.10.

All traffic and pedestrian signal heads and mounting

hardware shall be securely attached to the pole.

Traffic and pedestrian signal heads shall be correctly aimed in the field to the satisfaction of the Ministry Electrical Representative.

All traffic and pedestrian signal heads shall have LED (light emitting diode) traffic signal heads unless noted otherwise on the Drawings.

The Contractor shall completely cover all traffic and pedestrian signal heads with dark coloured pre manufactured signal cover bags from the time they are installed until the system is required by the Ministry.

The Contractor shall aim all traffic signal heads in accordance with Drawing SP635-2.3.11. Pedestrian signal heads shall be aimed to line up with the opposing wheelchair ramp or centre of the crosswalk.

635.17.02 Pedestrian Pushbuttons and Signs – Pedestrian pushbuttons and signs shall be installed in accordance with Drawing SP635-2.3.7.

Pedestrian push buttons and signs shall be securely attached to the pole. Pedestrian pushbutton signs shall be temporarily covered until the signal is in operation.

635.17.03 Luminaires and Photocells – Luminaires and photocells shall be installed as per manufacturer's instructions or as noted on the Drawings. Luminaires shall be installed level. Where the luminaire has a multi-tap ballast, the Contractor shall verify the service voltage and adjust the luminaire voltage tap to suit.

When installing flat glass cobra head roadway luminaires the flat glass lens shall be oriented parallel to the roadway surface to reduce glare.

Sign luminaires will require different aiming depending on the manufacturer. Aiming angles shall be noted on the Drawings or shall be requested from the Ministry Electrical Representative.

Photocell eyes shall be aimed north.

635.17.04 Streetname Signs – Streetname signs shall be bolted directly to the pole arms in accordance with Drawing SP635-3.2.1.

635.17.05 Audible Signals -Audible Signals shall be installed on pedestrian signal heads in accordance with Drawing SP635-2.3.8. The Contractor shall aim and adjust the audible signal heads to the satisfaction of the Ministry Electrical Representative.

635.17.06 Emergency Vehicle Pre-emption Equipment – Emergency vehicle pre-emption equipment shall be installed in accordance with the Drawings and manufacturer's instructions. The Contractor shall undertake all commissioning and set-up of the equipment under the direction of the supplier technical representative.

635.17.07 Small Overhead Signs – Small overhead signs are classed as signs 1200 mm x 900 mm or smaller. Small

SECTION 635

ELECTRICAL AND SIGNING

overhead signs shall be installed in accordance with Drawings SP635-3.2.2 through SP635-3.2.6.

Sign installations shall meet the requirements of SS 635.32.

635.17.08 Video Detection Equipment – Video Detection equipment shall be installed in accordance with the Drawings and manufacturer's instructions. The cameras shall be installed on signal arms or on special combination type 2A luminaire / camera arms in accordance with Drawings SP635-2.3.12 and 2.3.13. The Contractor shall undertake all commissioning and set-up of the equipment under the direction of the supplier technical representative.

635.17.09 Payment – Payment for the installation of each SIGNAL POLE will be at the Lump Sum Price for that pole.

The Lump Sum Price shall include all costs for the installation of traffic signal poles and arms, traffic signal heads including mounting hardware, pedestrian pushbuttons and signs, luminaires and photocells, audible signals, street name signs, small overhead signs, and fire indication lights; supply and installation of wiring to the handhole at the base of the pole, fuse holders, fuses and splices; and all other labour, equipment and material necessary to complete the installation.

635.17.10 Payment – Payment for the installation of LUMINAIRE POLES will be at the Contract Unit Price for each pole.

The Unit Price shall include all costs for the installation of luminaire poles, luminaires and photocells, and frangible or breakaway bases; supply and installation of wiring to the handhole at the base of the pole, fuse holders, fuses and splices; and all other labour, equipment and materials necessary to complete the installation.

635.17.11 Payment – Payment for the supply and installation of EMERGENCY VEHICLE PRE-EMPTION EQUIPMENT will be made at the contract Lump Sum Price for each signal.

The Lump Sum shall include all costs for the installation of the pre-emption equipment, commissioning, set-up and adjusting.

635.17.12 Payment – Payment for the supply and installation of VIDEO DETECTION EQUIPMENT will be made at the contract Lump Sum Price for each signal.

The Lump Sum shall include all costs for the supply and installation of the video detection equipment, commissioning, set-up and adjusting.

635.18 Service Equipment – Service equipment shall be installed in accordance with Drawings SP635-2.4.1 through SP635-2.4.16.

Service Equipment shall include electrical panels and telephone demarcation panels.

Specialized service equipment (e.g., service kiosks) shall be installed in accordance with the Drawings and Special Provisions.

Service equipment shall be securely attached to the poles.

635.18.01 Payment – Payment for the installation of SERVICE EQUIPMENT will be at the Lump Sum Price for that service area.

The Lump Sum Price shall include all costs for the installation of electrical service, distribution and disconnect panels and telephone demarcation panels including the pole where a separate service pole is required; supply and installation of service wiring including wiring between the disconnect and distribution panels; supply and installation of rigid metal conduit, fittings, mounting hardware, ground wire, ground clamp, insulating clevis, ground plate and branch circuit wiring to the handhole at the base of the pole; supply and installation of a working pad including additional fill as required (see Drawing SP635-2.4.16); and all other labour, equipment and materials necessary to complete the installation.

635.19 Wiring – All wiring shall be installed in accordance with the Drawings or as directed by the Ministry Electrical Representative.

All conductors shall be stranded copper, RW90 XLPE insulated unless otherwise noted.

Conductor gauges (AWG) shall be as specified on the Drawings.

Shielded detector loop and telephone demarcation cables shall be 2 conductor No. 18 Ministry pre-approved product. Shielded detector loop cables shall run continuous with no splices, from the traffic controller (or other type of control equipment) to the respective detector loop conductor.

Single conductor colour coding and labelling is required and shall be as noted on Drawings SP635-2.5.7 and 2.5.8. Conductor colour coding shall also meet the requirements of the Canadian Electrical Code.

Where specifically noted on the Drawings signal cable shall be used. Signal cable colour coding and conductor designations shall be as noted on Drawing SP635-2.5.9. Where signal cable is used all conductor splices shall be made in pole hand holes in accordance with Drawing SP635-2.5.10.

Each traffic and pedestrian signal head section and luminaire shall be wired separately to the base of the pole. A separate neutral and bond conductor shall run to each signal head and luminaire from the base of the pole. The neutral and bond conductors shall be bundled with the feeder circuits.

Luminaire conductor wiring and fusing in pole handholes shall conform to Drawing SP635-2.5.6.

Wiring inside junction boxes and vaults shall conform to Drawings SP635-2.5.1 through SP635-2.5.5.

Conductor splices shall be secured with solderless "Marrette" type connectors. Where the number and/or size of conductors exceed the capacity of the Marrette, split bolt connectors shall be used.

All wiring shall be neatly bundled and labelled in all junction boxes, vaults, traffic controllers, handholes at pole bases, and service panels.

Sealing of connections shall be performed using one of the following methods:

- a) Double dipping using 3M "Scotchcote" or approved alternate. Dipping shall be performed strictly adhering to the manufacturer's specifications.
- b) Each conductor shall have a wrap of the self-holding tape (3M Linerless Rubber Splicing Tape, Steadfast 8 Ounce Splicing tape or approved alternate), then the complete splice shall be wrapped. PVC tape shall then be applied to cover the complete splice.

If conductor connections require the use of split bolts or similar style devices due to wire size, then the splice shall be completely covered with Duct Seal to form a ball over the connection. This Duct Seal shall be thick enough to prevent sharp ends of the conductors and/or points of the connector from protruding through the taped connection. Once the duct seal has been applied, the splice shall be taped with self-holding and PVC tape as described in SS 635.19(b).

All luminaires and signal heads shall be bonded with a No. 12 RW90 conductor. Steel junction box lids and steel vault lids shall be bonded in accordance with Drawings SP635-2.5.1 through SP635-2.5.5.

635.19.01 Payment – Payment for the installation of WIRING will be at the Lump Sum Price for all underground wiring included in the Work.

The Lump Sum Price shall include all costs for the supply and installation of wiring and cables located in the underground conduit system (unless otherwise noted) and splices; labelling of underground conductors; and all other labour, equipment and materials necessary to complete the installation.

635.20 Traffic Counter Stations – Traffic counter stations shall be short-duration type or permanent type.

Short duration traffic counter stations shall be installed in accordance with Drawing SP635-2.6.1.

Perforated square steel tubing shall conform to SS 635.28.

Permanent traffic counter stations shall be installed in accordance with Drawing SP635-2.6.2 and 2.6.3.

The Contractor will install all pole mount cabinets. The Ministry Electrical Maintenance Contractor will connect all field wiring in cabinets, trouble-shoot problems in the cabinet and undertake all equipment set-up.

635.20.01 Payment – Payment for the installation of TRAFFIC COUNTER STATIONS will be at the Contract Unit Price per traffic counter station.

The Unit Price shall include all costs for the supply and installation of perforated steel tubing, above ground conduit and junction boxes, connectors; supply and installation of rigid metal conduits, fittings, mounting hardware and branch circuit wiring to the handhole at the base of pole for pole mount cabinets; installation of counter cabinet including the pole where a separate pole is required; Supply and installation of W-55 signs and concrete pad in front of the controller door; and all other labour, equipment and materials necessary to complete the installation.

635.21 Controllers – Type B, C, M and S traffic controller cabinets shall be installed in accordance with Drawings SP635-2.7.1 through SP635-2.7.3.

The Ministry Electrical Maintenance Contractor will install all base mount traffic controller and cabinets. The Contractor will install all pole mount cabinets. The Ministry Electrical Maintenance Contractor will connect all field wiring in controller cabinets, trouble-shoot problems in the cabinet, enter all signal timings, undertake modifications to existing signal phasing and timings, start-up controller and complete Ministry signal turn-on sheets.

The Contractor shall be on hand to assist with controller start-up and make any repairs to field wiring or hardware as required. The Contractor shall provide traffic control and assistance during the controller start-up.

The Contractor shall coil and label 2 m of each conductor inside the traffic controller for connections by the Ministry Electrical Maintenance Contractor or Ministry Electrical Trades Supervisor. The Contractor shall verify that all traffic and pedestrian signal phases are wired as shown on the Drawings and that all circuits are tested prior to activation. The Contractor shall verify that all signal and pedestrian phases are properly colour coded and labelled with identification tags.

635.21.01 Payment – Payment for the installation of each CONTROLLER will be at the Lump Sum Price for that controller.

The Lump Sum Price shall include all costs for the installation of pole mount cabinets and installation of the pole where a separate pole is required, rigid metal conduits, fittings, mounting hardware and branch circuit wiring to the handhole at the base of pole for pole mount cabinets; testing of all circuits; labelling of all conductors; traffic control and all other labour, equipment and materials necessary to complete the installation.

635.22 Detector Loops – Detector loops shall be constructed as noted on the Drawings and shall be installed in accordance with Drawings SP635-2.8.1 through SP635-2.8.16. Loop check sheets shall be

completed and submitted to the Ministry Manager, Electrical Services prior to signal start-up.

635.22.01 Payment – Payment for DETECTOR LOOPS will be at the Contract Unit Price per loop.

The Unit Price shall include all costs for layout of the loop, asphalt cutting and preparation of pavement cuts; supply and installation of loop conductors or preformed loops as applicable, to the underground junction box, traffic counter post or cabinet; supply and installation of backer rod, sand and loop sealant; and all other labour, equipment and materials necessary to complete the installation.

635.23 Repairing Galvanized Surfaces – Any spots where the galvanized finish is damaged due to drilling, tapping, reaming or welding and any surface damage incurred during transportation and erection shall be refinished with cold galvanizing compound. Cold galvanizing compound shall be Crown No. 67007 spray type (or approved alternative). The application of cold galvanizing compound shall conform to the Manufacturer's instructions and the following:

- a) The surface shall be mechanically cleaned with a wire brush or grinder and chemically cleaned to remove all welding flux, paint, grease, oil, rust, scale or other detrimental foreign matter.
- b) The surface shall be absolutely dry and the ambient temperature shall be over 10°C.
- c) Uniform coats shall be applied. Each coat shall be as thick as possible without causing runs on the finished surface.

All costs for the repair of galvanized surfaces will be considered incidental to the Work.

635.24 Flasher Luminaires – Flasher luminaires shall be mounted on perforated square steel tubing in accordance with Drawings SP635-2.9.1 through SP635-2.9.3.

Flasher luminaires shall be mounted on poles in accordance with Drawings SP635-2.9.4 through SP635-2.9.6.

All perforated square steel tubing shall be in accordance with SS 635.28.

635.24.01 Payment – Payment for the installation of Flasher Luminaires on Perforated Square Steel Tubing will be at the Contract Unit Price for a one or two sign unit.

The Unit Price shall include all costs for the supply and installation of perforated square steel tubing, mounting hardware, wiring to the junction box nearest to the flasher post, ty-raps and connectors, signs, flasher luminaires, lamps; and all other labour, equipment and materials necessary to complete the installation.

635.24.02 Payment – Payment for the installation of Flasher Luminaires on Poles will be at the Contract Unit Price for each item.

The Unit Price shall include all costs for the supply and installation of all fittings, hardware and wiring to the underground junction box nearest the pole, signs, flasher luminaires and lamps; and all other labour, equipment and materials necessary to complete the installation.

PART D – SIGNING

635.25 Overhead Signs – Overhead signs are categorized in two classes:

- a) small overhead sheet aluminium or plywood signs are 1200 mm x 900 mm or smaller;
- b) large overhead sheet aluminum, plywood or extruded aluminum guide signs are larger than 1200 mm x 900 mm.

Small overhead signs are generally plywood or sheet aluminum, and are mounted on signal poles. Small overhead signs shall be installed in accordance with Drawings SP635-3.2.2 through SP635-3.2.6.

Large overhead guide signs are installed on sign poles in accordance with Drawings SP635-3.3.1 through SP635-3.3.6, unless otherwise noted. Large overhead extruded aluminum signs are installed on sign poles in accordance with Drawings SP635-3.3.11 through SP635-3.3.17, unless otherwise noted. Sign poles shall be installed in accordance with Drawings SP635-3.1.1 through SP535-3.1.19. Large overhead plywood signs are not typically used for new installations.

Sign lighting, where specified by the Ministry, shall be installed in accordance with Drawing SP635-3.3.18 and SS 635.17.03.

Overhead signs shall be securely installed on sign pole structures.

All horizontal supports and signs shall be level and vertical supports plumb.

Sign Poles shall be installed in accordance with SS 635.17.

Advance warning signs shall be extruded aluminum, and shall be installed in accordance with Drawings SP635-3.3.7 through SP635-3.3.10.

All signs shall be installed in accordance with SS 635.32.

635.25.01 Payment – Payment for the installation of each OVERHEAD SIGN POLE will be at the Lump Sum Price for that sign pole.

The Lump Sum Price shall include all costs for installation of sign poles and arms, overhead signs complete with T Section mounting brackets and clips, advance warning flasher equipment, sign luminaries and mounting hardware; small overhead signs and mounting brackets, wiring to the handhole at the base of the pole, fuse holders, fuses, junction boxes on pole arms, splices; and all other labour, equipment and materials necessary to complete the installation.

Where small overhead signs are installed on signal poles, payment will be made under SS 635.17.08.

635.26 Breakaway Sign Structures – Breakaway sign structures shall be installed in accordance with Drawings SP635-3.4.1 through SP635-3.4.12.

After concrete bases are installed, the Contractor shall survey the finished base elevations to determine the correct leg lengths. The fabricator shall cut legs to the correct lengths.

All legs and columns are to be transported in an unstressed manner.

All breakaway structures shall be installed with the legs and columns plumb, and the battens and signs level.

The Contractor shall tighten all bolts and nuts with a torque wrench to the torque specified on the drawings.

Signs shall be sheet aluminum plywood or extruded aluminum, as specified.

Plywood signs shall generally be installed in accordance with Drawings SP635-3.4.7, -3.4.8 and SS 635.32.

Plywood signs shall be installed with wood battens on the breakaway sign columns to support the signs. Wood battens shall be 4" x 6" Douglas Fir/Larch, No. 1 Grade and pressure treated, surfaced four sides, in complete lengths without splices. Battens shall be straight and free of cracks.

All pressure treated wood battens shall be pressure treated in accordance with CSA Standard O80.2 "Preservative Treatment of Lumber, Timber, Bridge Ties and Mine Ties by Pressure Processes"

Extruded aluminum signs shall be installed in accordance with Drawings SP635-3.4.9 through SP635-3.4.12 and SS 635.32.

Extruded aluminum signs on breakaway sign structures will not be illuminated.

All sign installations shall be in accordance with SS 635.32.

635.26.01 Payment – Payment for the installation of each BREAKAWAY SIGN STRUCTURE will be at the Lump Sum Price for that breakaway sign structure.

The Lump Sum Price shall include all costs for the installation of breakaway sign legs, columns, stub posts, fuse and connection joints, sign or signs, sign luminaires and mounting brackets, wood battens, painting, sign mounting bolts and hardware for plywood signs; and all other labour, equipment and materials necessary to complete the installation.

635.27 Wood Post Sign Structures – Wood post sign structures shall be installed in accordance with Drawings SP635-3.5.1 through SP635-3.5.9.

Excavations for wood posts shall be wide enough to allow for proper compaction of backfill around the wood posts. Wood posts shall be embedded in the ground to the depths indicated on Drawings SP635-3.5.1 through SP635-3.5.3.

Wood post excavations shall be backfilled using the excavated material except where excavated material is ruled unacceptable by the Ministry Representative. Where new material is required, 25 mm Well Graded Base Course Aggregate material shall be used as specified in SS 635.14. Unacceptable materials shall be disposed of as specified in SS 635.15.

Wood posts shall be Douglas Fir/Larch, No. 1 Grade and pressure treated, surfaced four sides, and shall be supplied in complete lengths without splices. Posts shall be straight and free of cracks.

All pressure treated wood posts and battens shall be pressure treated in accordance with CSA Standard O80.2 "Preservative Treatment of of Lumber, Timber, Bridge Ties and Mine Ties by Pressure Processes"

Wood posts shall be installed plumb and at the proper offset and elevation.

Backfill material shall be placed in layers not exceeding 150 mm compacted thickness and shall be compacted to a minimum 100% of the laboratory density obtained by the current ASTM test method D 698. Layer thickness and moisture content of the material shall be adjusted as necessary to achieve compaction.

All areas excavated and backfilled shall be restored to their original condition.

Signs on single wood post structures shall be plywood or sheet aluminum. Sheet aluminum signs shall be installed in accordance with Drawing SP635-3.5.1 and SS 635.32.

Signs on multiple wood post structures shall be sheet aluminum, plywood or extruded aluminum.

Plywood signs shall be installed in accordance with Drawings SP635-3.5.4 and 3.5.5, and SS 635.32.

Plywood signs shall be installed on wood battens mounted on the sign posts to support the signs. Wood battens shall be Douglas Fir/Larch, No. 1 Grade and pressure treated, surfaced four sides, and shall be supplied in complete lengths without splices. Wood battens shall be straight and free of cracks.

Extruded aluminum signs shall be installed in accordance with Drawings SP635-3.5.6 through SP635-3.5.9 and SS 635.32.

Signs or battens or extruded aluminum signs and angle mounting brackets shall not be installed on wood posts until the paint has completely dried.

All areas around the post shall be fully restored to their original condition.

635.27.01 Payment – Payment for the installation of SINGLE WOOD POST SIGN STRUCTURES will be at the Contract Unit Price for each wood post sign structure.

The Unit Price shall include all costs of Types B, C and D excavation, other than concrete or asphalt removal; supply and installation of wood posts, painting (where required),

sign mounting bolts and hardware and signs; placing and compaction of excavated materials as backfill; removal of excess excavated material; restoration; and all other labour, equipment and materials necessary to complete the installation.

Payment for excavation of Type A material (solid rock) will be made on a Force Account Basis unless otherwise noted.

De-watering of excavations will be paid for by Force Account.

Where excavated material is ruled unacceptable for backfill, payment for 25 mm Well Graded Base Course Aggregate will be made under SS 635.14.01.

635.27.02 Payment – Payment for the installation of each MULTI POST WOOD POST SIGN STRUCTURE will be at the Lump Sum Price for that wood post sign structure.

The Lump Sum Price shall include all costs of Type B, C, and D excavation, other than concrete or asphalt removal; supply and installation of wood posts, painting, sign mounting bolts and hardware, battens for plywood signs, sign(s) and aluminum angle sign supports for extruded aluminum signs; placing and compaction of excavated materials as backfill; removal of excess excavated material; restoration and all other labour, equipment and materials necessary to complete the installation.

Payment for excavation of Type A material (solid rock) will be made on a Force Account Basis unless otherwise noted.

De-watering of excavations will be paid for by Force Account.

Where excavated material is ruled unacceptable for backfill, payment for 25 mm Well Graded Base Course Aggregate will be made under SS 635.14.01.

635.28 Perforated Square Steel Sign Post Structures – Perforated Square Steel Sign Post shall be supplied in accordance with Drawings SP635-3.6.1 through SP635-6.4.

Sign posts shall be perforated square steel tubing. The perforated square steel tubing will be required in different outside dimensions as noted on the Drawings. The perforated square steel tubing shall be formed from 12 gauge hot rolled steel, conforming to ASTM Specification A 1011 Grade 50. The tubing shall be hot dipped galvanized conforming to ASTM Specification A 653 Designation G-90 or CSA Specification G164. Steel tubing shall have 7/16" holes on all four sides at 1" centres.

Galvanized perforated square steel tubing shall be supplied in continuous lengths, with no splices, and shall be field cut to suit the particular installation. All field cuts shall be painted with cold galvanizing compound in accordance with SS 635.23.

Perforated square steel tubing sign posts shall be installed on concrete bases or direct buried in accordance with Drawing SP635-1.1.35.

Perforated square steel tubing posts shall be installed plumb.

Signs on single perforated square steel sign posts shall be sheet aluminum or steel. Sheet aluminum and steel signs shall be installed in accordance with Drawings SP635-3.6.1, 3.6.3 and SS 635.32.

Signs on double perforated square steel sign posts shall be plywood or sheet aluminum.

Double post plywood and sheet aluminum signs shall be installed in accordance with Drawings SP635-3.6.2 through SP635-3.6.4 and SS 635.32.

635.28.01 Payment – Payment for the installation of SINGLE PERFORATED SQUARE STEEL SIGN POST STRUCTURES will be at the Contract Unit Price for each structure.

The Unit Price shall include all costs for the supply and installation of perforated square steel tubing, mounting hardware, sign(s); and all other labour, equipment and materials necessary to complete the installation.

635.28.02 Payment – Payment for DOUBLE PERFORATED SQUARE STEEL SIGN POST STRUCTURES will be at the Contract Unit Price for each sign structure.

The Unit Price shall include all costs for the supply and installation of perforated square steel tubing; mounting hardware, sign(s); and all other labour, equipment and materials necessary to complete the installation.

635.29 Round Steel Sign Post Structures – Round Steel sign posts shall be installed in accordance with Drawings SP635-3.8.1 through SP635-3.8.3.

Barrier sign posts shall be mounted on barrier stands, which shall be securely bolted to concrete roadside or concrete median barriers.

Posts and pipe sleeves shall be round Schedule 40 steel pipe conforming to ASTM Specification A 53, Grade A or B, Type E or S. The pipe shall be hot dip galvanized in accordance with CSA Specification G164. Pipe shall be field cut to lengths to suit sign mounting heights as noted on the Drawings or as directed by the Ministry Representative. All field cuts in galvanized steel pipes shall be coated with cold galvanizing compound in accordance with SS 635.23.

Signs shall be installed in accordance with SS 635.32.

635.29.01 Payment – Payment for the installation of ROUND STEEL SIGN POST STRUCTURES will be at the Contract Unit Price for each sign post.

The Unit Price shall include all costs for the supply and installation of sign or signs and barrier stands, sign posts and mounting hardware, breakaway devices, where

warranted, pipe sleeves including trenching and backfilling where posts are installed in concrete sidewalks; and all other labour, equipment and materials necessary to complete the installation.

635.30 Sign Mounting on the Side of Poles – Signs mounted on the side of steel poles shall be installed in accordance with Drawing SP635-3.9.1.

Signs shall be securely attached to poles.

Signs shall be installed in accordance with SS 635.32.

Holes drilled in galvanized steel poles shall be coated with cold galvanizing compound in accordance with SS 635.23.

635.30.01 Payment – Payment for the installation of SIGN INSTALLATION ON THE SIDE OF POLES will be at the Contract Unit Price for signs installed on each pole.

The Unit Price shall include all costs for the supply and installation of signs, sign mounting hardware; and all other labour, equipment and materials necessary to complete the installation.

Where multiple signs are to be installed on a pole only one unit item will be paid.

635.31 Delineators – Delineators shall be wood, perforated steel tubing or plastic as noted on the Drawings or as directed by the Ministry Representative.

Wood delineator posts shall be installed in accordance with Drawing SP635-3.10.1.

Perforated square steel tubing delineator posts shall be installed in accordance with Drawing SP635-3.10.2.

Where plastic delineators are specified, they shall be a Ministry preapproved type and shall be installed in accordance with the manufacturer's instructions.

Where delineators are mounted on a pole, sign post or structure, they shall be installed in accordance with Drawing SP635-3.10.3.

Wood delineator post excavation, backfill, type of wood, painting and installation methods shall be in accordance with SS 635.27.

Perforated square steel tubing shall be in accordance with SS 635.28.

All holes drilled in galvanized surfaces shall be coated with cold galvanizing compound in accordance with SS 635.23.

635.31.01 Payment – Payment for the installation of DELINEATORS will be at the Contract Unit Price for each delineator.

The Unit Price shall include all costs of excavation, other than concrete or asphalt removal; supply and installation of delineator posts and mounting hardware, W-0055 background plate and reflectors for perforated sign posts and W-055 reflectors for wood sign posts; placing and

compaction of excavated materials as backfill; removal of excess excavated materials; and all other labour, equipment and materials necessary to complete the installation.

635.32 Signs – Small signs which are generally 1200 mm x 900 mm or smaller shall be sheet aluminum or plywood. Large signs which are generally larger than 1200 mm x 900 mm shall be plywood or extruded aluminum as specified.

All sign installations shall meet the requirements of the most current edition of the Ministry *Manual of Standard Traffic Signs and Pavement Markings* available at:

http://www.th.gov.bc.ca/publications/eng_publications/electrical/MoST_PM.pdf.

The Contractor shall have a current copy of this document on site when installing signs.

All signs shall be completely covered with a suitable grade of polyethylene sheeting from the time they are installed until the roadway is in full operation, unless otherwise directed by the Ministry Representative. The polyethylene sheeting material shall prevent sign messages from being visible.

All signs shall be handled so as not to damage them in any way. Slip sheets between signs shall be removed carefully to avoid damage due to adhesion of the slip sheet to the sign. Signs shall be stored on end on dunnage or racks in a dry, covered area, safe from damage. Damaged signs shall be replaced by the Contractor at the Contractor's expense. Taping, screwing, nailing, gluing, bolting or stapling to sign faces or back is prohibited unless otherwise noted.

The Contractor shall confirm that all signs have the correct messaging. The Contractor shall verify that all signs are free of cracks, dents or warpage prior to installation. Any sign flaws shall be immediately reported to the Ministry Representative prior to sign installation.

Signs shall be bolted to the mounting hardware or structure as indicated on the applicable Drawings. Nylon washers shall be installed between the mounting bolt heads and the plywood sign face. The sign panels shall be tightened so as to eliminate sign movement but not over tightened so as to recess the bolt heads into the sign face.

Plywood signs larger than 1200 mm x 3000 mm will consist of multiple plywood panels. Each panel shall be correctly aligned so that no gaps exist between sign panels. The bottom of the sign panels shall be installed level.

Plywood exit number tabs shall be attached to plywood signs in accordance with Drawing SP635-3.7.1.

Extruded aluminum signs will be supplied unassembled. Aluminum sign sections shall be assembled and correctly aligned to the satisfaction of the Ministry Representative.

SECTION 635

Extruded aluminum signs are supplied in typical widths shown on Drawing SP635-3.3.13.

Extruded aluminum exit number tabs shall attach to extruded aluminum signs in accordance with Drawings SP635-3.7.2 and -3.7.3.

Any unused holes in wooden sign boards shall be sealed to the satisfaction of the Ministry Representative. Holes on the sign face shall be covered with a trimmed piece of patching material to match the colour of the sign face.

Patching material shall meet current Ministry Specifications.

All plywood, sheet aluminum and extruded aluminum signs will be identified with their sign numbers labelled on the back.

The Contractor shall maintain all signs installed as part of the work within the project area for the duration of the

ELECTRICAL AND SIGNING

Work. Maintenance shall be performed for the duration of the work in accordance with the following:

a) Sign maintenance shall include the straightening, replacing, repairing and cleaning of all signs installed under the work which is considered by the Ministry's Representative in need of repair and cleaning.

b) The Contractor shall regularly inspect the signs to ensure consistent maintenance for maximum visibility.

c) Where directed by the Ministry Representative the Contractor shall clean the signs by power washing or steam cleaning using pressures not exceeding 7 MPa and temperatures not exceeding 65°C. Chemical washing of sign faces will not be accepted.

All costs for installation and maintenance of signs shall be included in the prices for the applicable items.

CONCRETE BASE INDEX			
TYPE	SP635 DRAWING	POLE TYPES	STYLE
A	1.1.2	TYPE 4 SHAFTS	SONOTUBE
B	1.1.2	TYPE 4A AND 5 SHAFTS	SONOTUBE
C	1.1.3	7.5m, 9.0m AND 11.0m LUMINAIRE POLES, TYPES 4, 4A AND 5 SHAFTS	TRAPEZOIDAL
D1	1.1.4 TO 1.1.6	13.5m LUMINAIRE POLES	SPREAD FOOTING
D2	1.1.7 & 1.1.8		TRAPEZOIDAL
D3	1.1.9 & 1.1.10		RECTANGULAR
E1	1.1.4 TO 1.1.6	TYPE 1 & 3 SHAFTS	SPREAD FOOTING
E2	1.1.7 & 1.1.8		TRAPEZOIDAL
E3	1.1.9 & 1.1.10		RECTANGULAR
F1	1.1.11 TO 1.1.13	TYPE 6 & 7 SHAFTS	SPREAD FOOTING
F2	1.1.14 & 1.1.15		TRAPEZOIDAL
F3	1.1.16 & 1.1.17		RECTANGULAR
S1	1.1.11 TO 1.1.13	TYPE S POLES	SPREAD FOOTING
S2	1.1.14 & 1.1.15		TRAPEZOIDAL
S3	1.1.16 & 1.1.17		RECTANGULAR
L1	1.1.11 TO 1.1.13	TYPE L POLES	SPREAD FOOTING
L2	1.1.14 & 1.1.15		TRAPEZOIDAL
L3	1.1.16 & 1.1.17		RECTANGULAR
M1	1.1.20 TO 1.1.22	TYPE M POLES	SPREAD FOOTING
M2	1.1.23 & 1.1.24		RECTANGULAR
H1	1.1.26 TO 1.1.28	TYPE H POLES	SPREAD FOOTING
H2	1.1.29 & 1.1.30		RECTANGULAR
-	1.1.32 TO 1.1.34	BREAKAWAY SIGN STRUCTURES	SPREAD FOOTING
-	1.1.35 & 1.1.36	SIGN POSTS BASES	SONOTUBE
-	1.1.37	POST MOUNTED FLASHER CONCRETE BASE	SONOTUBE
-	1.1.38 TO 1.1.41	CONTROLLER BASE	TRAPEZOIDAL
-	1.1.42 & 1.1.43	ANCHOR BOLT REPAIR PROCEDURES	-

NOTES

- SEE STANDARD SPECIFICATIONS & SPECIAL PROVISIONS FOR ADDITIONAL INFORMATION.



NOT TO SCALE

No.	Revision	Date	CONCRETE BASE INDEX	
F			Date Approved	
E				
D			SPECIFICATION DRAWING No.	
C	TYPE S BASES ADDED	OCT 03		
B	DRAWING LIST REVISED	AUG 95	30/09/93 E.L. (Signature on File) Chief Highway Engineer	
A	GENERAL REVISIONS	AUG 94		
			SP635-1.1.1	

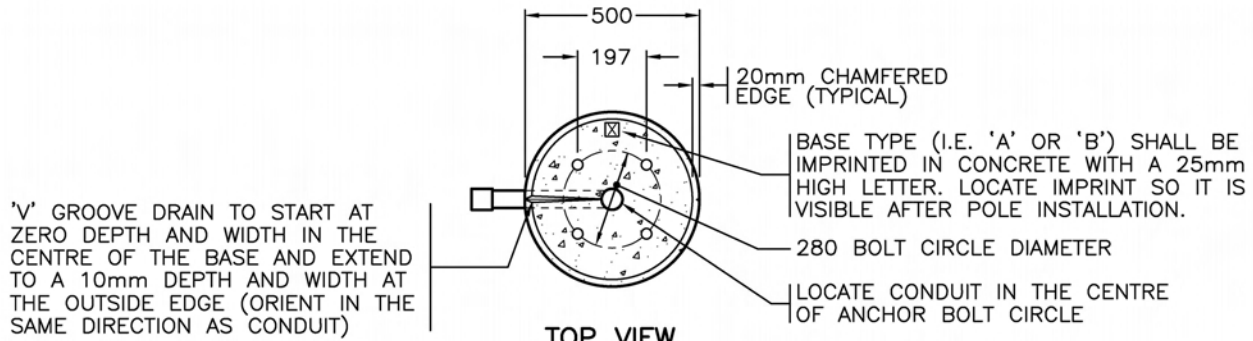

TOP VIEW

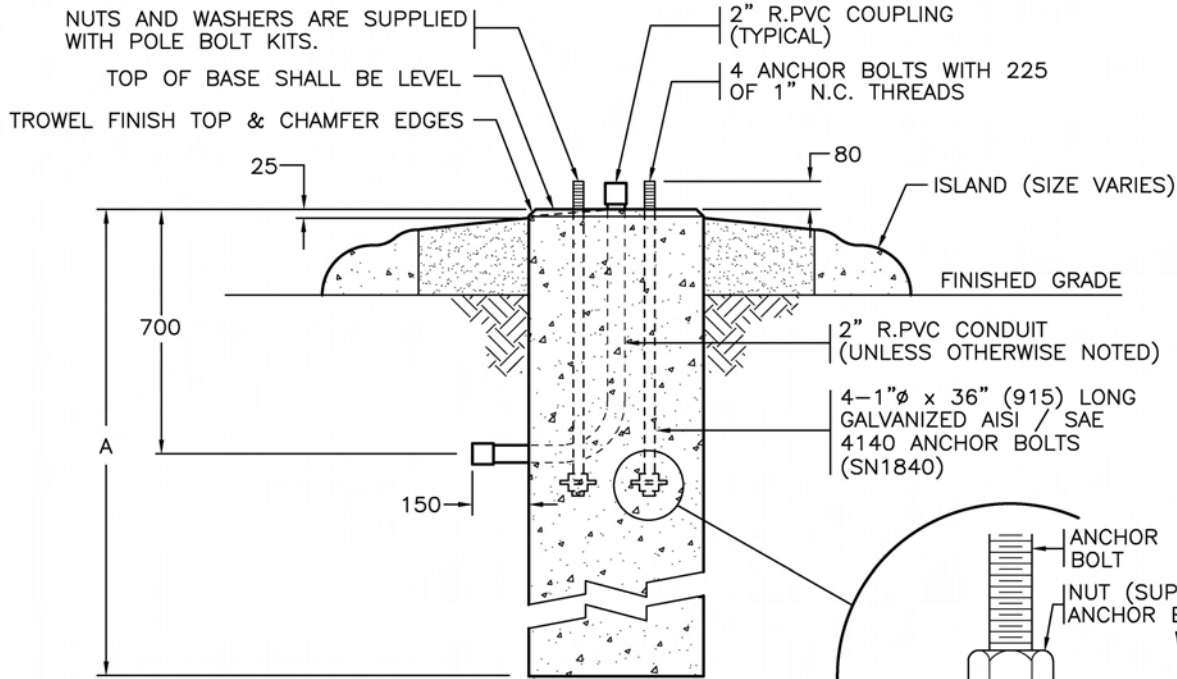

ELEVATION

CONCRETE SHALL HAVE ATTAINED A COMPRESSIVE STRENGTH OF 30MPa PRIOR TO POLE INSTALLATION.

STEEL PLATE (SUPPLIED WITH ANCHOR BOLT)

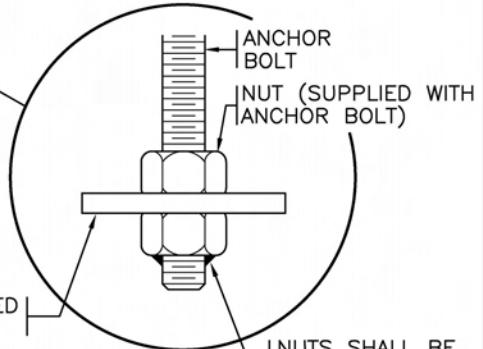

NUTS SHALL BE SUPPLIED TACK WELDED TO ANCHOR BOLTS.

BASE TYPE	POLE TYPE	APPROXIMATE MASS	VOLUME OF CONCRETE	A
A	TYPE 4 SHAFT	620 kg	0.24 m ³	1200
B	TYPE 4A AND 5 SHAFTS	760 kg	0.30 m ³	1500

NOTES

- SEE STANDARD SPECIFICATIONS & SPECIAL PROVISIONS FOR ADDITIONAL INFORMATION.
- 'SN' DENOTES MINISTRY STOCK NUMBER.
- ALL DIMENSIONS ARE IN MILLIMETRES UNLESS OTHERWISE NOTED.
- SEE DRAWINGS SP635-1.4.1 TO 1.4.4 FOR BACKFILL REQUIREMENTS.

NOT TO SCALE



No.	Revision	Date
F		
E		
D		
C		
B	NOTE 4 ADDED	AUG 95
A	GENERAL REVISIONS	AUG 94

TYPES A AND B CONCRETE BASES (PRECAST OR Poured IN PLACE)		
Date	Approved	SPECIFICATION DRAWING No.
30/09/93	E.L. (Signature on File) Chief Highway Engineer	SP635-1.1.2

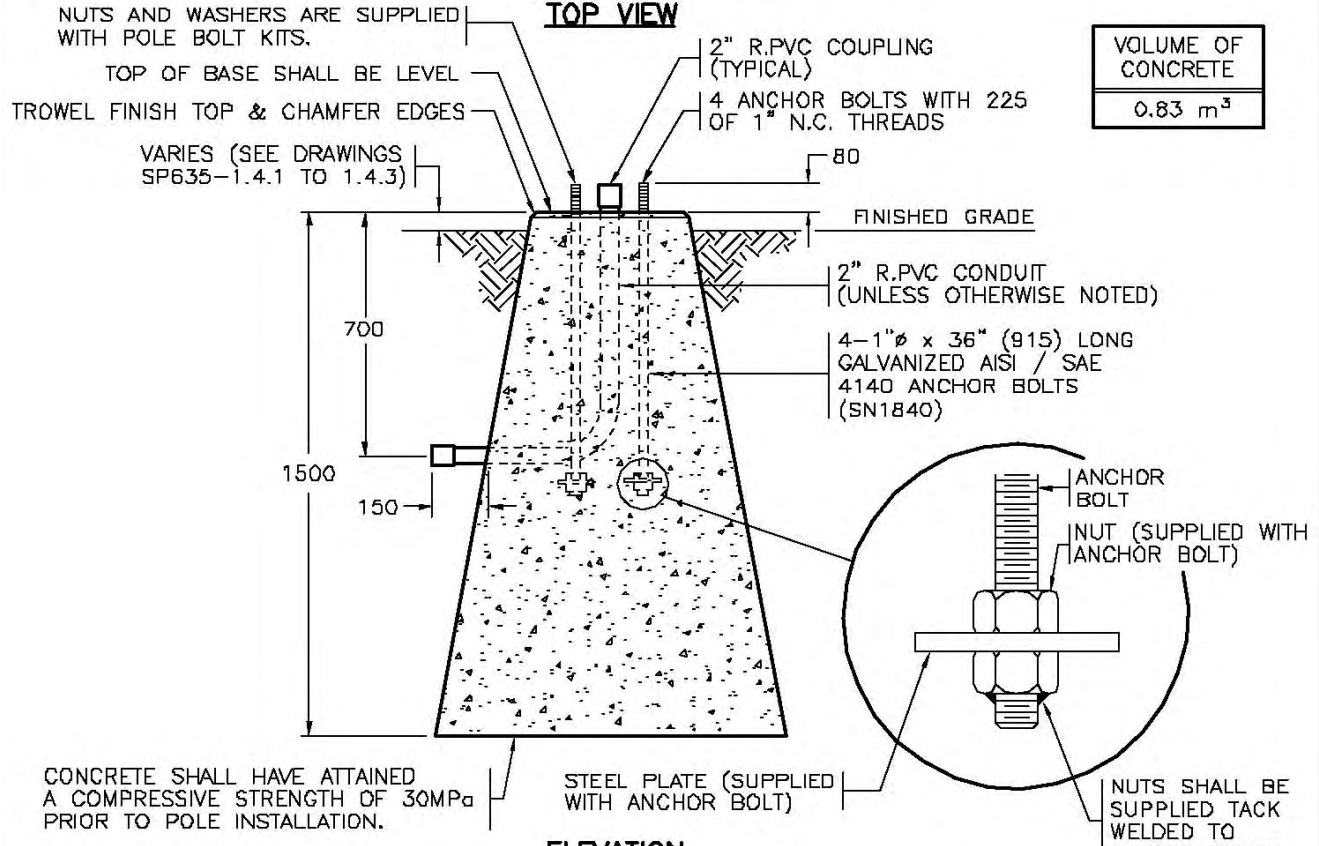
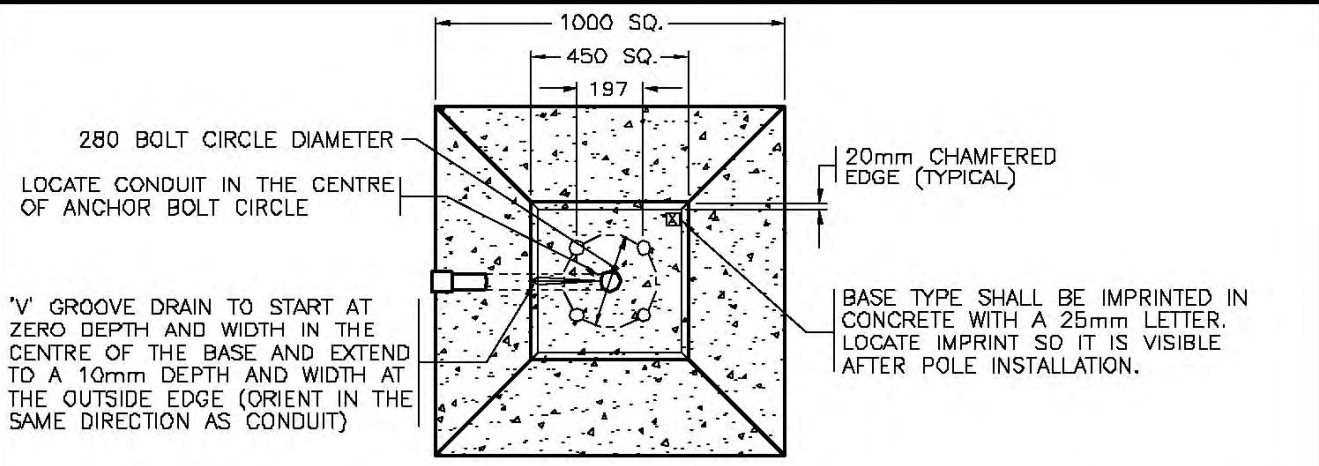

VOLUME OF CONCRETE
0.83 m ³

CONCRETE SHALL HAVE ATTAINED A COMPRESSIVE STRENGTH OF 30MPa PRIOR TO POLE INSTALLATION.

ELEVATION

NOTES

1. SEE STANDARD SPECIFICATIONS & SPECIAL PROVISIONS FOR ADDITIONAL INFORMATION.
 2. 'SN' DENOTES MINISTRY STOCK NUMBER. aaaa
 3. ALL DIMENSIONS ARE IN MILLIMETRES UNLESS OTHERWISE NOTED.
 4. SEE DRAWINGS SP635-1.4.1 TO 1.4.4 FOR BACKFILL REQUIREMENTS.
- NOT TO SCALE

BASE TYPE	POLE TYPE	APPROXIMATE MASS
C	7.5m, 9.0m AND 11.0m LUMINAIRE POLES AND TYPES 4, 4A AND 5 SHAFTS	2000 kg



No.	Revision	Date
F		
E		
D		
C		
B	ELEVATION OF BASE TO FINISHED GRADE REVISED	AUG 95
A	GENERAL REVISIONS	AUG 94

**TYPE C CONCRETE BASE
(PRECAST OR POURED IN PLACE)**

Date	Approved	SPECIFICATION DRAWING No.
30/09/93	E.L. (Signature on File) Chief Highway Engineer	SP635-1.1.3

BASE TYPE (I.E. 'D1' OR 'E1') SHALL BE IMPRINTED IN CONCRETE WITH A 25mm HIGH LETTER. LOCATE IMPRINT SO IT IS VISIBLE AFTER POLE INSTALLATION.

B (ANCHOR BOLT CIRCLE)
C (ANCHOR BOLTS)

CONCRETE SHALL HAVE ATTAINED A COMPRESSIVE STRENGTH OF 30MPa PRIOR TO POLE INSTALLATION.

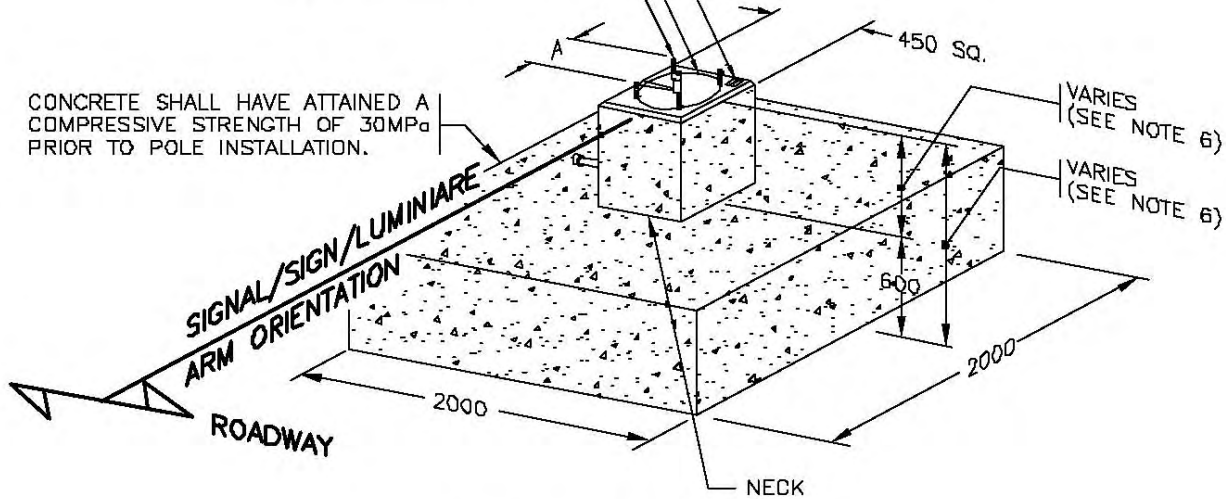

CONCRETE SPREAD FOOTING

BASE TYPE	POLE TYPE	VOLUME OF CONCRETE	MASS OF REBAR	FORMWORK	APPROXIMATE MASS	A	B	C (ANCHOR BOLTS)
D1	13.5m LUMINAIRE POLES	2.7 m ³ *	260 kg *	7.3 m ² *	6600 kg*	216	305	4-1 1/4"φ x 48" (1220) GALVANIZED AISI / SAE 4140 (SN1851)
E1	TYPE 1 AND 3 SHAFTS	2.7 m ³ *	260 kg *	7.3 m ² *	6600 kg*	197	280	4-1"φ x 36" (915) GALVANIZED AISI / SAE 4140 (SN1840)

(*) BASED ON SPREAD FOOTING WITH 1400 HIGH NECK

NOTES

- SEE STANDARD SPECIFICATIONS & SPECIAL PROVISIONS FOR ADDITIONAL INFORMATION.
- SEE PLANS FOR SIGNAL/SIGN/LUMINAIRE ARM ORIENTATION.
- 'SN' DENOTES MINISTRY STOCK NUMBER.
- SEE DRAWINGS SP635-1.1.5, 1.1.6 & 1.4.5 FOR ADDITIONAL DETAILS.
- ALL DIMENSIONS ARE IN MILLIMETRES UNLESS OTHERWISE NOTED.
- NECK HEIGHT MAY VARY FROM 750 to 1400. SEE DRAWING SP635-1.4.5 FOR MDRE INFORMATION.

aaaa

BASE DESIGNED FOR SOILS WITH A MINIMUM BEARING PRESSURE OF 100KPa

NOT TO SCALE



No.	Revision	Date	TYPE D1 & E1 CONCRETE SPREAD FOOTINGS (POURED IN PLACE OR PRECAST)	
F			Date	Approved
E			15/11/95	M.C. (Signature on File)
D			Chief Highway Engineer	
C			SPECIFICATION DRAWING No.	
B			SP635-1.1.4	
A				

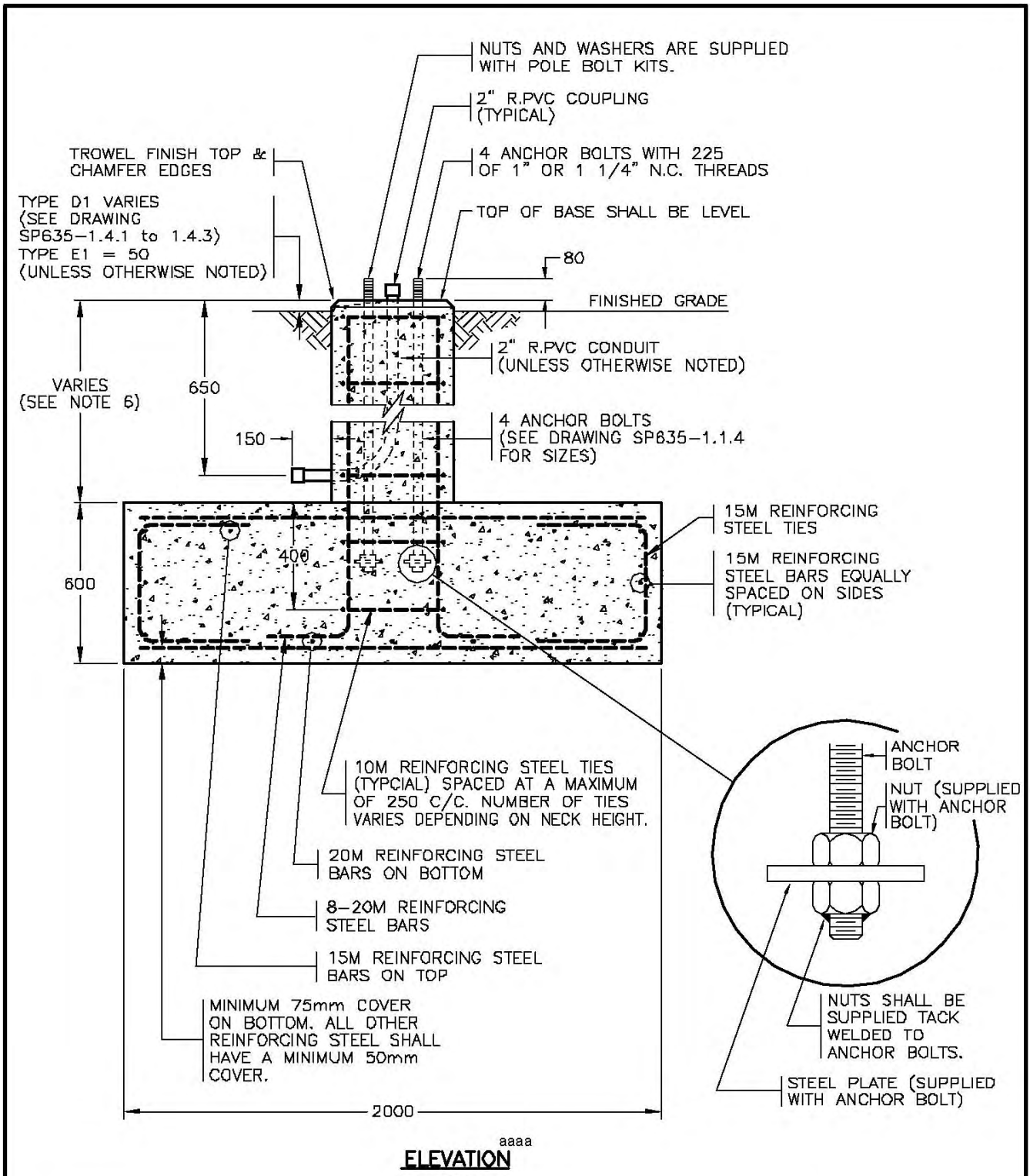

SEE DRAWING SP635-1.1.4 FOR NOTES AND ADDITIONAL DETAILS



NOT TO SCALE

No.	Revision	Date	TYPE D1 & E1 CONCRETE SPREAD FOOTINGS (POURED IN PLACE OR PRECAST)		SPECIFICATION DRAWING No. SP635-1.1.5
F			Date	Approved	
E					
D					
C					
B					
A	ELEVATION OF BASE TO FINISHED GRADE REV'D	AUG 96	15/11/95	M.C. (Signature on File) Chief Highway Engineer	

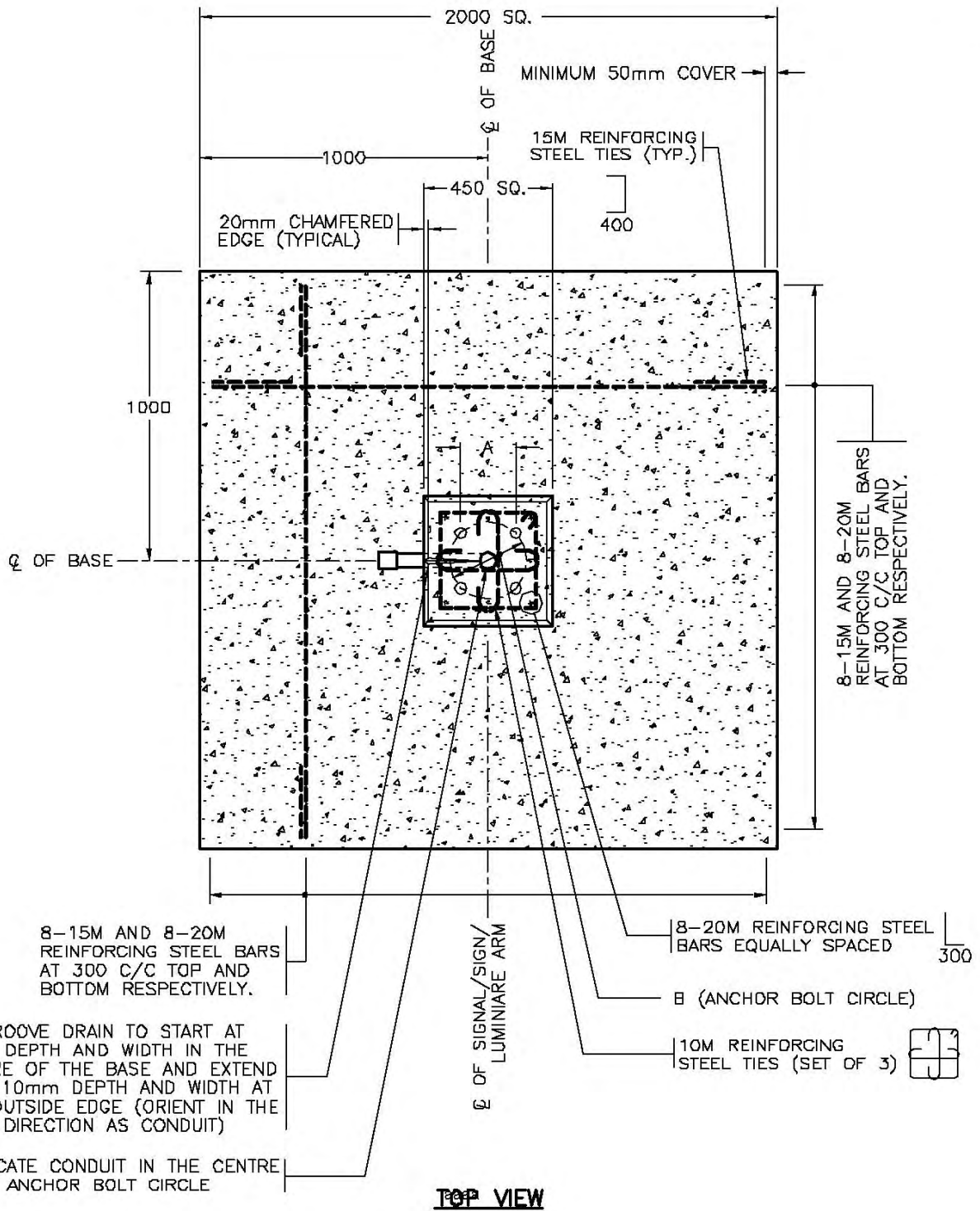

SEE DRAWING SP635-1.1.4 FOR NOTES AND ADDITIONAL DETAILS



NOT TO SCALE

No.	Revision	Date	TYPE D1 & E1 CONCRETE SPREAD FOOTINGS (POURED IN PLACE OR PRECAST)		SPECIFICATION DRAWING No. SP635-1.1.6
F			Date	Approved	
E			15/11/95	M.C. (Signature on File)	
D				Chief Highway Engineer	
C					
B					
A					

BASE TYPE (I.E. 'D2' OR 'E2') SHALL BE IMPRINTED IN CONCRETE WITH A 25mm HIGH LETTER. LOCATE IMPRINT SO IT IS VISIBLE AFTER POLE INSTALLATION.

B (ANCHOR BOLT CIRCLE)
C (ANCHOR BOLTS)

CONCRETE SHALL HAVE ATTAINED A COMPRESSIVE STRENGTH OF 30MPa PRIOR TO POLE INSTALLATION.

SEE DRAWING SP635-1.1.8 FOR REBAR DETAILS

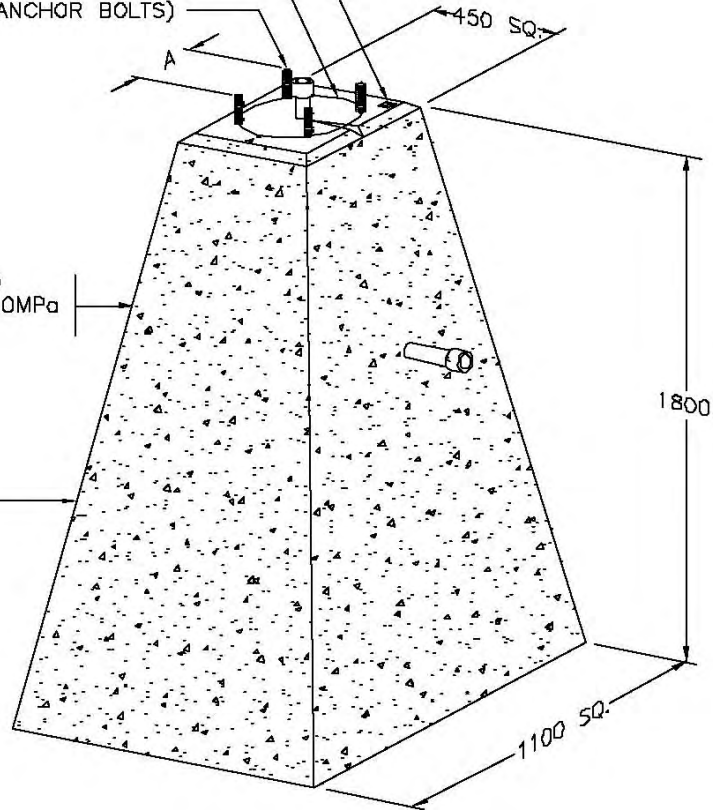

PRECAST CONCRETE BASES

BASE TYPE	POLE TYPE	APPROXIMATE MASS	VOLUME OF CONCRETE	A	B	C (ANCHOR BOLTS)
D2	13.5m LUMINAIRE POLES	2450 kg	1.0 m ³	216	305	4-1 1/4"φ x 48" (1220) GALVANIZED AISI / SAE 4140 (SN1851)
E2	TYPE 1 AND 3 SHAFTS	2410 kg	1.0 m ³	197	280	4-1"φ x 36" (915) GALVANIZED AISI / SAE 4140 (SN1B40)

NOTES

1. SEE STANDARD SPECIFICATIONS & SPECIAL PROVISIONS FOR ADDITIONAL INFORMATION.
2. 'SN' DENOTES MINISTRY STOCK NUMBER.
3. ALL DIMENSIONS ARE IN MILLIMETRES UNLESS OTHERWISE NOTED.
4. SEE DRAWING SP635-1.1.8 FOR ADDITIONAL DETAILS.
5. SEE DRAWINGS SP635-1.4.1 TO 1.4.4 FOR BACKFILL REQUIREMENTS.

NOT TO SCALE



No.	Revision	Date	TYPES D2 AND E2 CONCRETE BASES (PRECAST)		SPECIFICATION DRAWING No.
F			Date	Approved	SP635-1.1.7
E			30/09/93	E.L. (Signature on File)	
D			Chief Highway Engineer		
C	REBAR DRAWING REFERENCE REVISED	AUG 96			
B	DRAWING NUMBER CHANGED	AUG 95			
A	GENERAL REVISIONS	AUG 94			

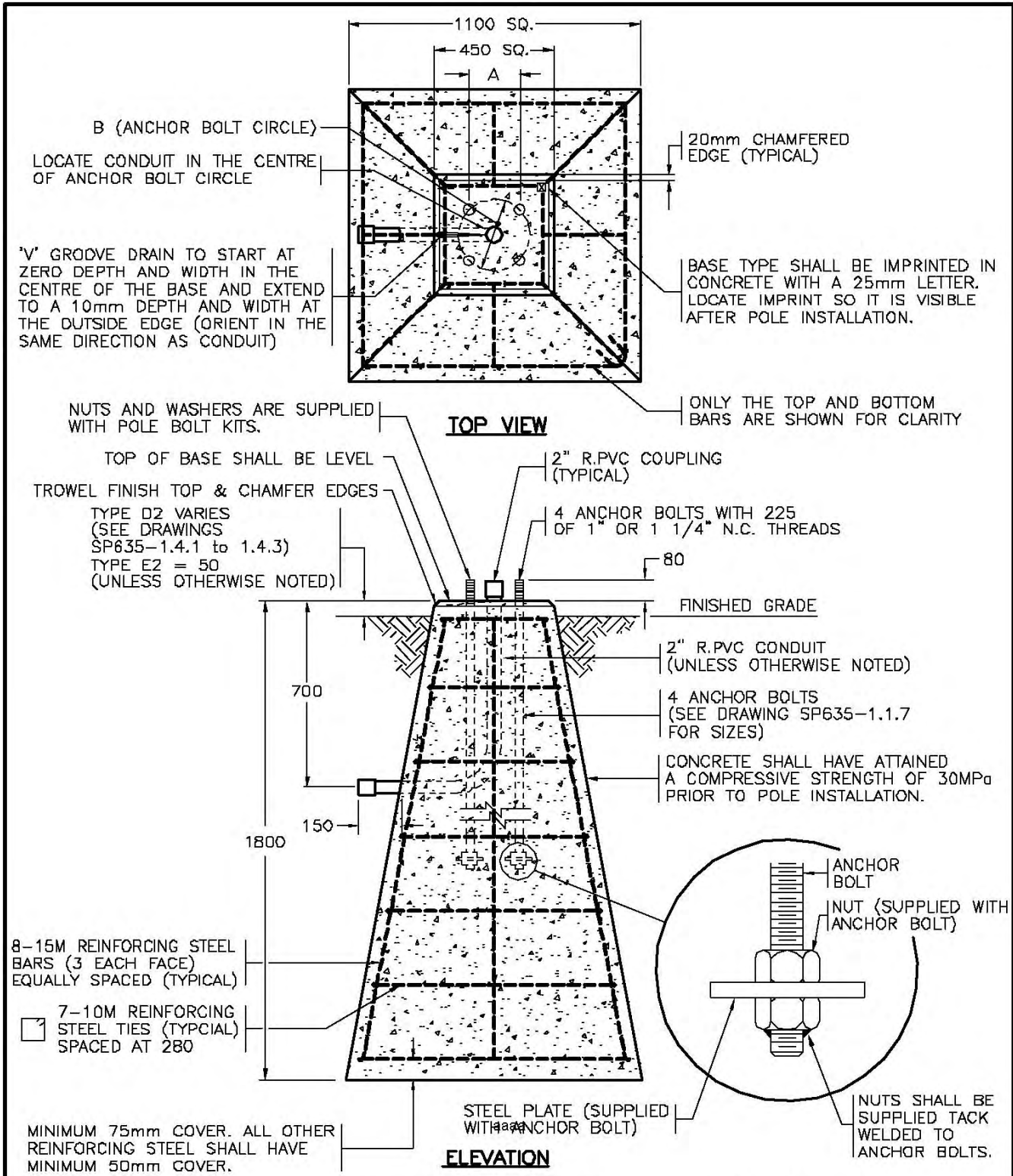

SEE DRAWING SP635-1.1.7 FOR NOTES AND ADDITIONAL DETAILS

NOT TO SCALE



No.	Revision	Date	TYPE D2 AND E2 CONCRETE BASES (PRECAST)		SPECIFICATION DRAWING No. SP635-1.1.8
F			Date	Approved	
E					
D					
C	ELEVATION OF BASE TO FINISHED GRADE REV'D	AUG 96	30/09/93	E.L. (Signature on File) Chief Highway Engineer	
B	REBAR ADDED	AUG 95			
A	GENERAL REVISIONS	AUG 94			

BASE TYPE (I.E. 'D3' OR 'E3') SHALL BE IMPRINTED IN CONCRETE WITH A 25mm HIGH LETTER. LOCATE IMPRINT SO IT IS VISIBLE AFTER POLE INSTALLATION.

B (ANCHOR BOLT CIRCLE)

C (ANCHOR BOLTS)

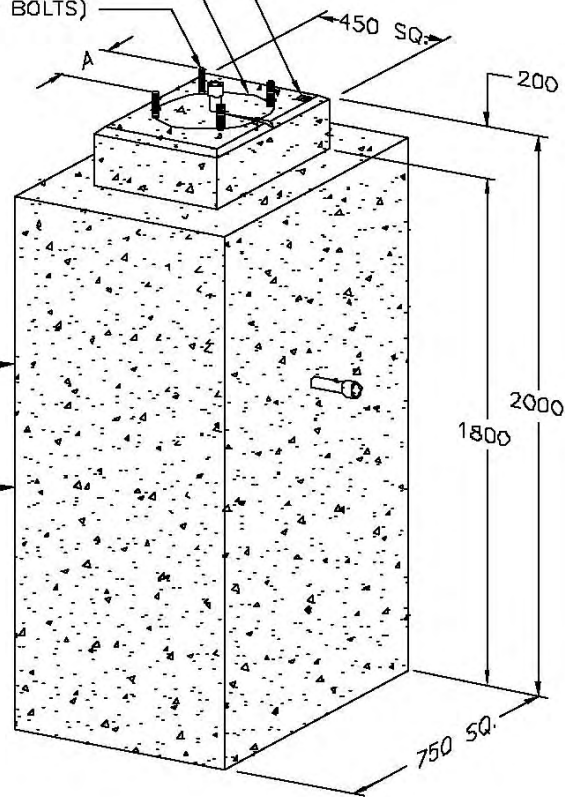

CONCRETE SHALL HAVE ATTAINED A COMPRESSIVE STRENGTH OF 30MPa PRIOR TO POLE INSTALLATION.

SEE DRAWING SP635-1.1.10 FOR REBAR DETAILS.

POURED IN PLACE CONCRETE BASES

BASE TYPE	POLE TYPE	APPROXIMATE MASS	VOLUME OF CONCRETE	A	B	C (ANCHOR BOLTS)
D3	13.5m LUMINAIRE POLES	2550 kg	1.05 m ³	216	305	4-1 1/4"φ x 48" (1220) GALVANIZED AISI / SAE 4140 (SN1851)
E3	TYPE 1 AND 3 SHAFTS	2510 kg	1.05 m ³	197	280	4-1"φ x 36" (915) GALVANIZED AISI / SAE 4140 (SN1840)

NOTES

- SEE STANDARD SPECIFICATIONS & SPECIAL PROVISIONS FOR ADDITIONAL INFORMATION.
- 'SN' DENOTES MINISTRY STOCK NUMBER.
- ALL DIMENSIONS ARE IN MILLIMETRES UNLESS OTHERWISE NOTED.
- SEE DRAWINGS SP635-1.1.10 FOR ADDITIONAL DETAILS.
- SEE DRAWINGS SP635-1.4.1 TO 1.4.4 FOR BACKFILL REQUIREMENTS.

aaaa



NOT TO SCALE

No.	Revision	Date	TYPE D3 AND E3 CONCRETE BASES (POURED IN PLACE)	
F			Date	Approved
E				
D				
C				
B	DRAWING NUMBER CHANGED	AUG 95	30/09/93	E.L. (Signature on File)
A	GENERAL REVISIONS	AUG 94		Chief Highway Engineer
			SPECIFICATION DRAWING No. SP635-1.1.9	

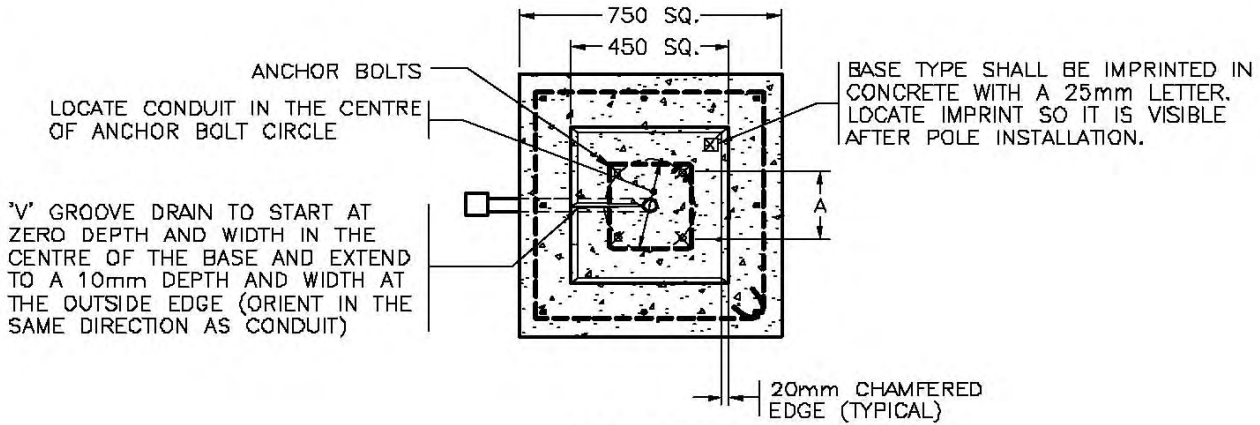

PLAN VIEW

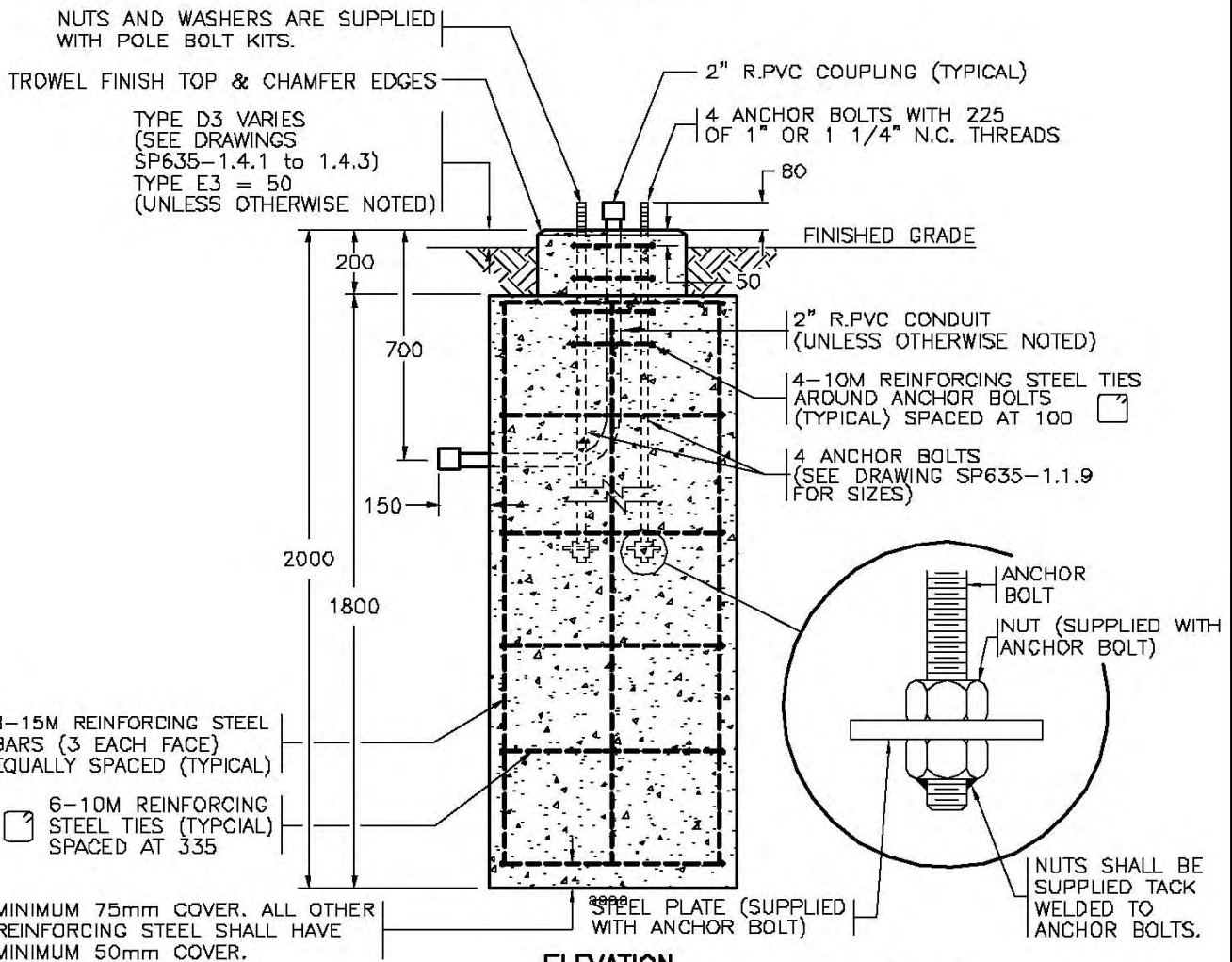

ELEVATION

SEE DRAWING SP635-1.1.9 FOR NOTES AND ADDITIONAL DETAILS

NOT TO SCALE



No.	Revision	Date
F		
E		
D		
C	ELEVATION OF BASE TO FINISHED GRADE REV'D	AUG 96
B	REBAR ADDED	AUG 95
A	GENERAL REVISIONS	AUG 94

TYPE D3 AND E3 CONCRETE BASES
(POURED IN PLACE)

Date Approved
30/09/93 E.L. (Signature on File)
Chief Highway Engineer

SPECIFICATION
DRAWING No.
SP635-1.1.10

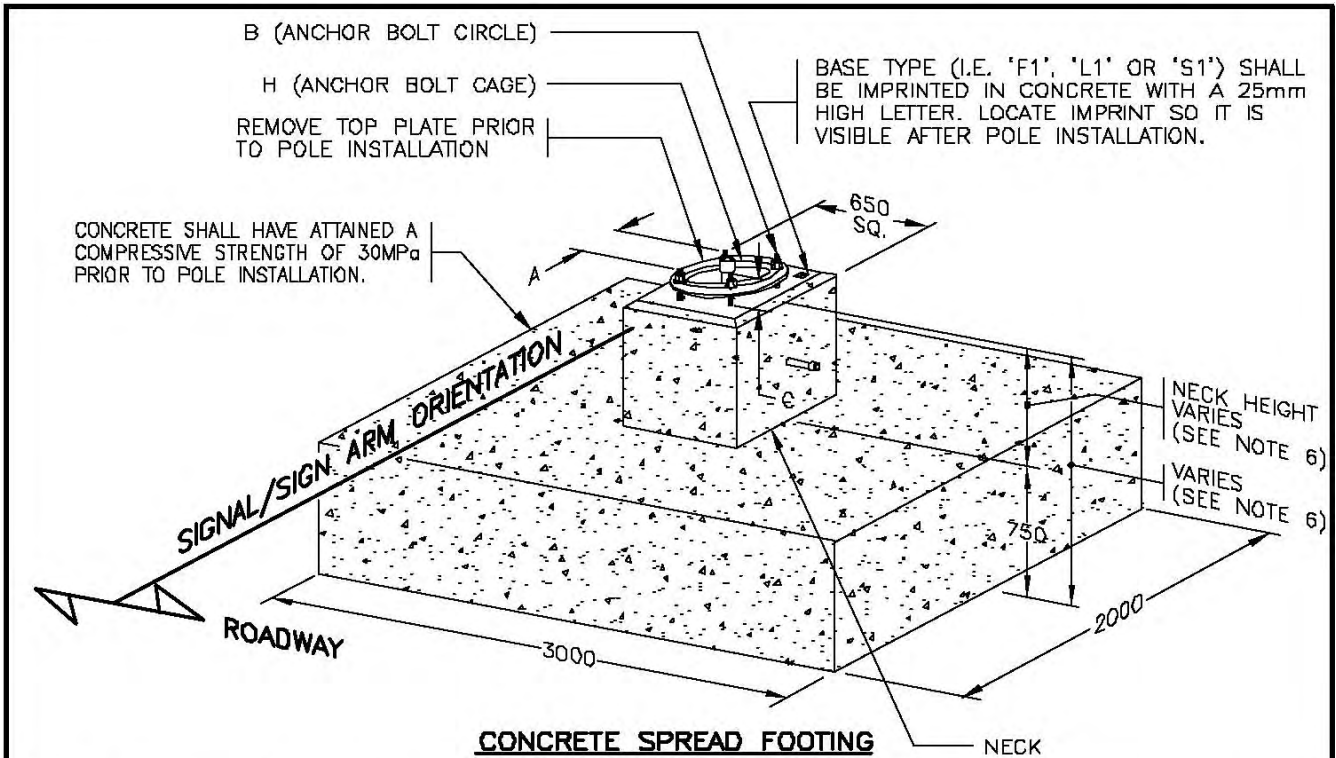

BASE TYPE	POLE TYPE	VOLUME OF CONCRETE	MASS OF REBAR	APPROXIMATE MASS	FORMWORK	A	B	C	H (ANCHOR BOLTS)
F1	TYPE 6 AND 7 SIGNAL POLES	5.0m ³	455 kg*	12306 kg*	11.0m ²	243	343	160	4-1"Ø x 48" (1220) GALVANIZED GRADE 150 DYWIDAG (SN1841A) PRE-ASSEMBLED IN A CAGE
S1	TYPE S SIGNAL POLES	5.0m ³	455 kg*	12306 kg*	11.0m ²	243	343	160	4-1"Ø x 48" (1220) GALVANIZED GRADE 150 DYWIDAG (SN1841A) PRE-ASSEMBLED IN A CAGE
L1	TYPE L SIGNAL POLES	5.0m ³	455 kg*	12306 kg*	11.0m ²	276	390	140	4-1 1/2"Ø x 54" (1370) GALVANIZED AISI / SAE 4140 (SN1839L) PRE-ASSEMBLED IN A CAGE

NOTES

- SEE STANDARD SPECIFICATIONS & SPECIAL PROVISIONS FOR ADDITIONAL INFORMATION.
- SEE PLANS FOR SIGNAL/SIGN ARM ORIENTATION.
- 'SN' DENOTES MINISTRY STOCK NUMBER.
- SEE DRAWINGS SP635-1.1.12, 1.1.13 & 1.4.5 FOR ADDITIONAL DETAILS.
- ALL DIMENSIONS ARE IN MILLIMETRES UNLESS OTHERWISE NOTED.
- NECK HEIGHT MAY VARY FROM 750 TO 1400. SEE DRAWING SP635-1.4.5 FOR MORE INFORMATION.

BASE DESIGNED FOR SOILS WITH A MINIMUM BEARING PRESSURE OF 100KPa

aaaa



NOT TO SCALE

No.	Revision	Date	TYPE F1, L1 & S1 CONCRETE SPREAD FOOTINGS (POURED IN PLACE)		
F					
E					
D					
C					
B			Date	Approved	SPECIFICATION DRAWING No.
A	TYPE S1 BASE ADDED	OCT 03	15/11/95	M.C. (Signature on File) Chief Highway Engineer	SP635-1.1.11

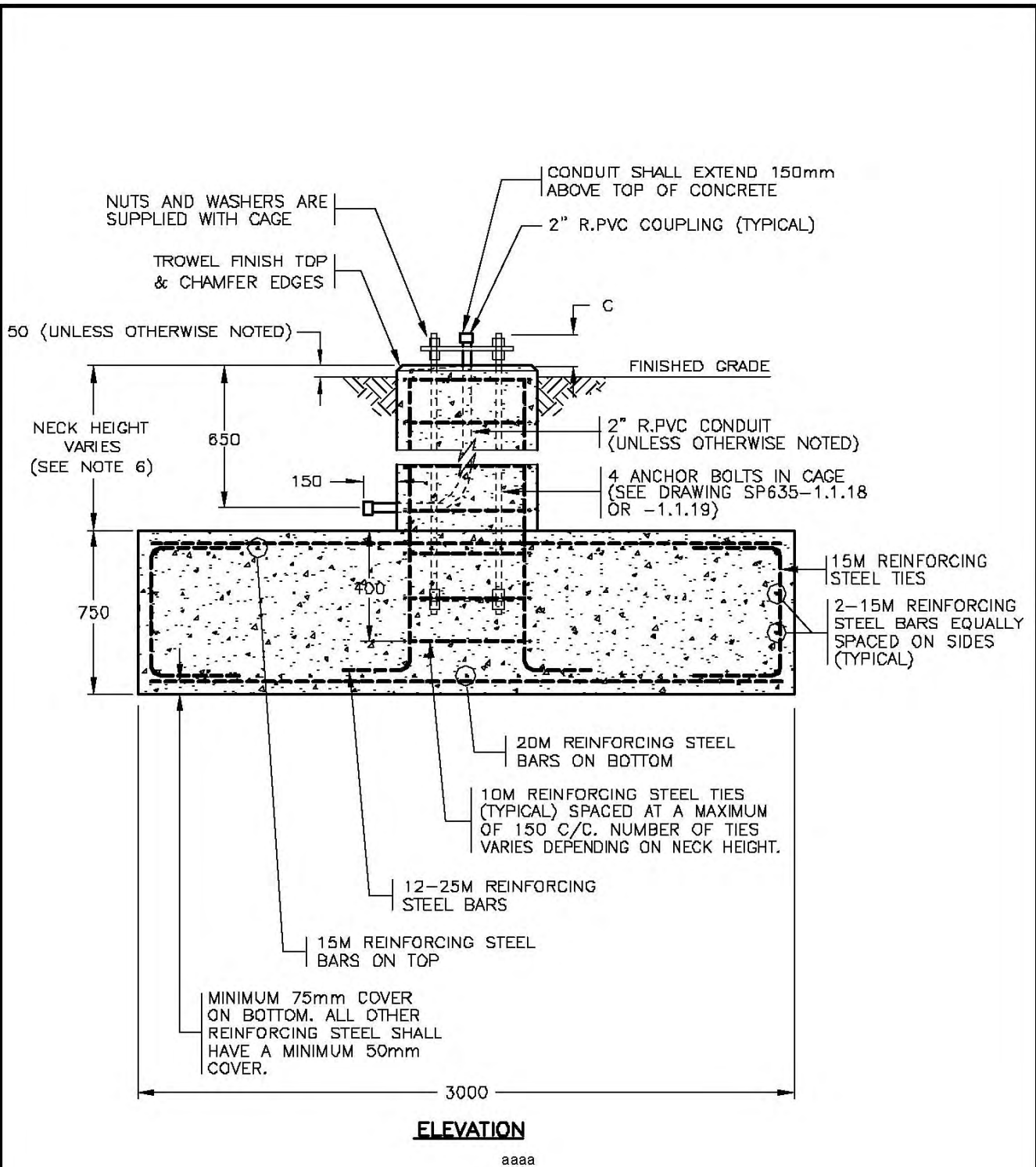

SEE DRAWING SP635-1.1.11 FOR NOTES AND ADDITIONAL DETAILS



NOT TO SCALE

No.	Revision	Date	TYPE F1, L1 & S1 CONCRETE SPREAD FOOTINGS (POURED IN PLACE)	
F			Date	Approved
E				
D				
C				
B	TYPE S1 BASE ADDED	OCT 03	15/11/95	M.C. (Signature on File)
A	ELEVATION OF BASE TO FINISHED GRADE REV'D	AUG 96		Chief Highway Engineer
			SPECIFICATION DRAWING No. SP635-1.1.12	

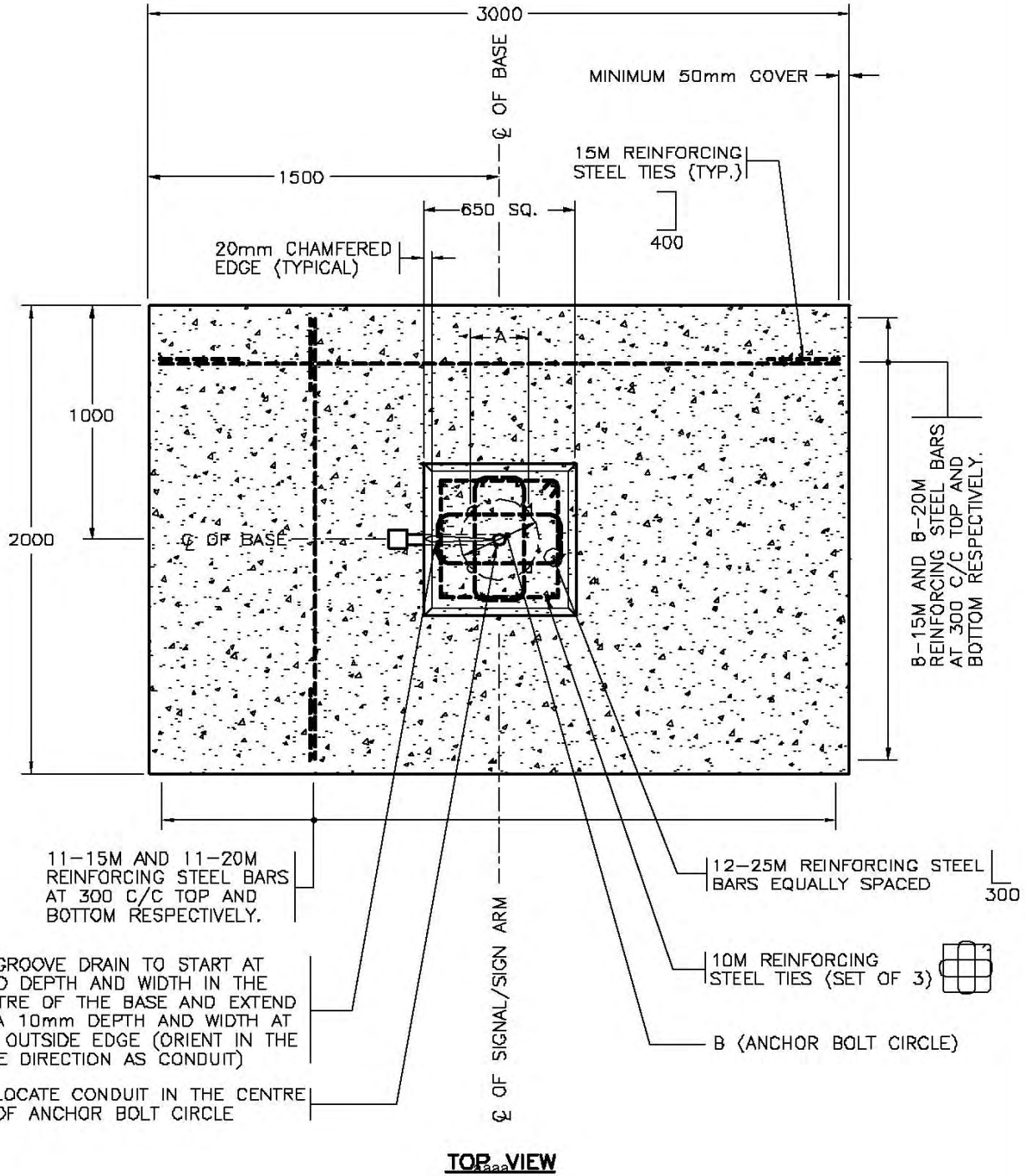

SEE DRAWING SP635-1.1.11 FOR NOTES AND ADDITIONAL DETAILS



NOT TO SCALE

No.	Revision	Date
F		
E		
D		
C		
B		
A	TYPE S1 BASE ADDED	OCT 03

**TYPE F1, L1 & S1 CONCRETE SPREAD FOOTINGS
(POURED IN PLACE)**

Date: 15/11/95
 Approved: M.C. (Signature on File)
 Chief Highway Engineer

SPECIFICATION
 DRAWING No.
SP635-1.1.13

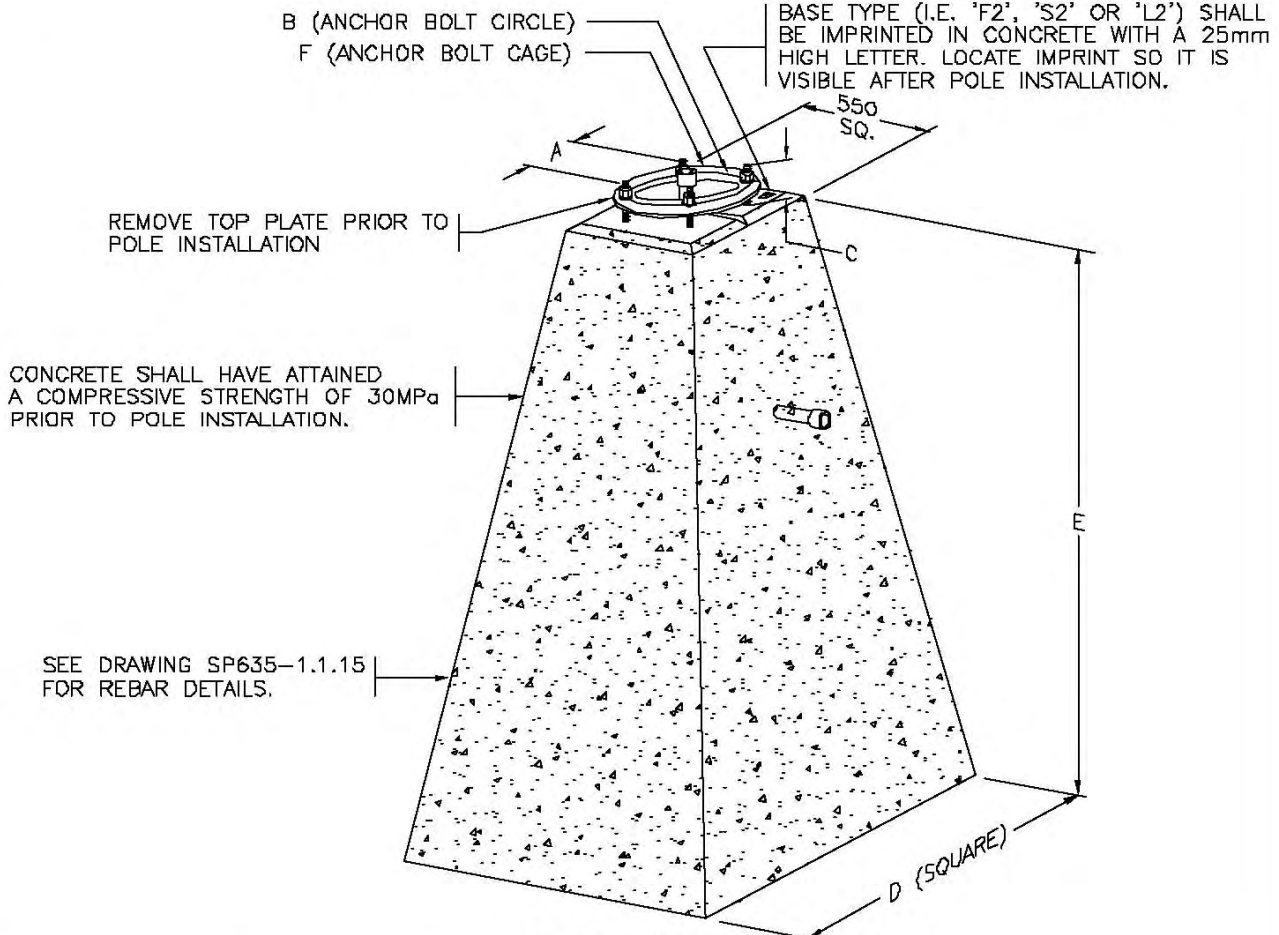

PRECAST CONCRETE BASES

BASE TYPE	POLE TYPE	APPROXIMATE MASS	VOLUME OF CONCRETE	A	B	C	D	E	F (ANCHOR BOLTS)
F2	TYPE 6 AND 7 SHAFTS	4500 kg	1.8 m ³	243	343	160	1240	2100	4-1"φ x 48" (1220) GALVANIZED GRADE 150 DYWIDAG (SN1841A) PRE-ASSEMBLED IN A CAGE
S2	TYPE S POLES	4500 kg	1.8 m ³	243	343	160	1240	2100	4-1"φ x 48" (1220) GALVANIZED GRADE 150 DYWIDAG (SN1841A) PRE-ASSEMBLED IN A CAGE
L2	TYPE L POLES	5040 kg	2.0 m ³	276	390	140	1300	2300	4-1 1/2"φ x 54" (1370) GALVANIZED AISI/SAE 4140 (SN1839L) PRE-ASSEMBLED IN A CAGE

NOTES

- SEE STANDARD SPECIFICATIONS & SPECIAL PROVISIONS FOR ADDITIONAL INFORMATION.
- 'SN' DENOTES MINISTRY STOCK NUMBER.
- ALL DIMENSIONS ARE IN MILLIMETRES UNLESS OTHERWISE NOTED.
- SEE DRAWING SP635-1.1.15 FOR ADDITIONAL DETAILS.
- SEE DRAWINGS SP635-1.4.1 TO 1.4.4 FOR BACKFILL REQUIREMENTS.

NOT TO SCALE



No.	Revision	Date	TYPE F2, L2 AND S2 CONCRETE BASES (PRECAST)		SPECIFICATION DRAWING No. SP635-1.1.14
F			Date	Approved	
E			30/09/93	E.L. (Signature on File) Chief Highway Engineer	
D					
C	TYPE S2 BASE ADDED	OCT 03			
B	DRAWING NUMBER CHANGED	AUG 95			
A	GENERAL REVISIONS	AUG 94			

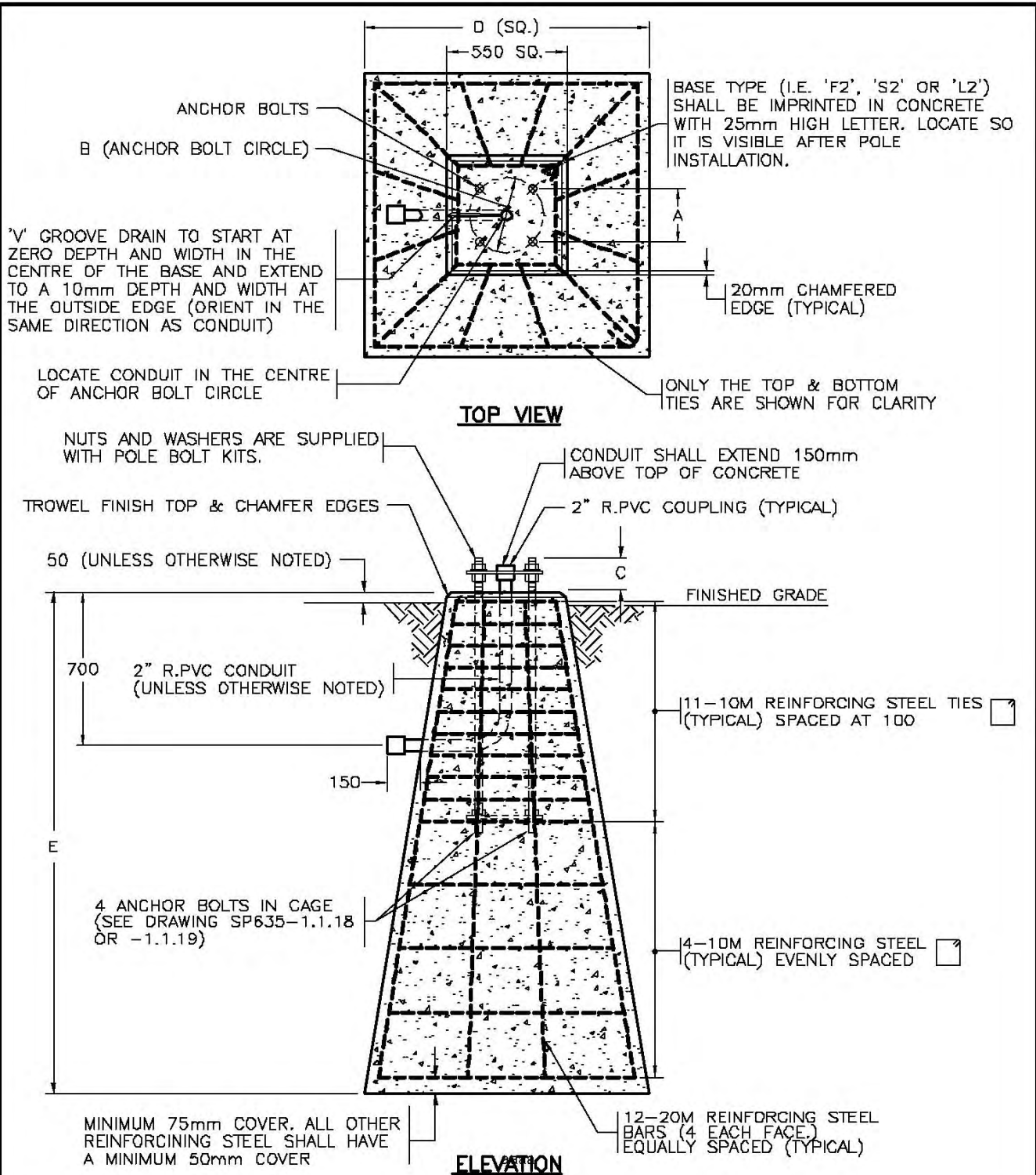

SEE DRAWING SP635-1.1.14 FOR NOTES AND ADDITIONAL DETAILS



NOT TO SCALE

No.	Revision	Date
F		
E		
D	TYPE S2 BASE ADDED	OCT 03
C	ELEVATION OF BASE TO FINISHED GRADE REVISED	AUG 96
B	ELEVATION OF BASE TO FINISHED GRADE REVISED	AUG 95
A	GENERAL REVISIONS	AUG 94

TYPE F2, L2 AND S2 CONCRETE BASES (PRECAST)		
Date	Approved	SPECIFICATION DRAWING No.
30/09/93	E.L. (Signature on File) Chief Highway Engineer	SP635-1.1.15

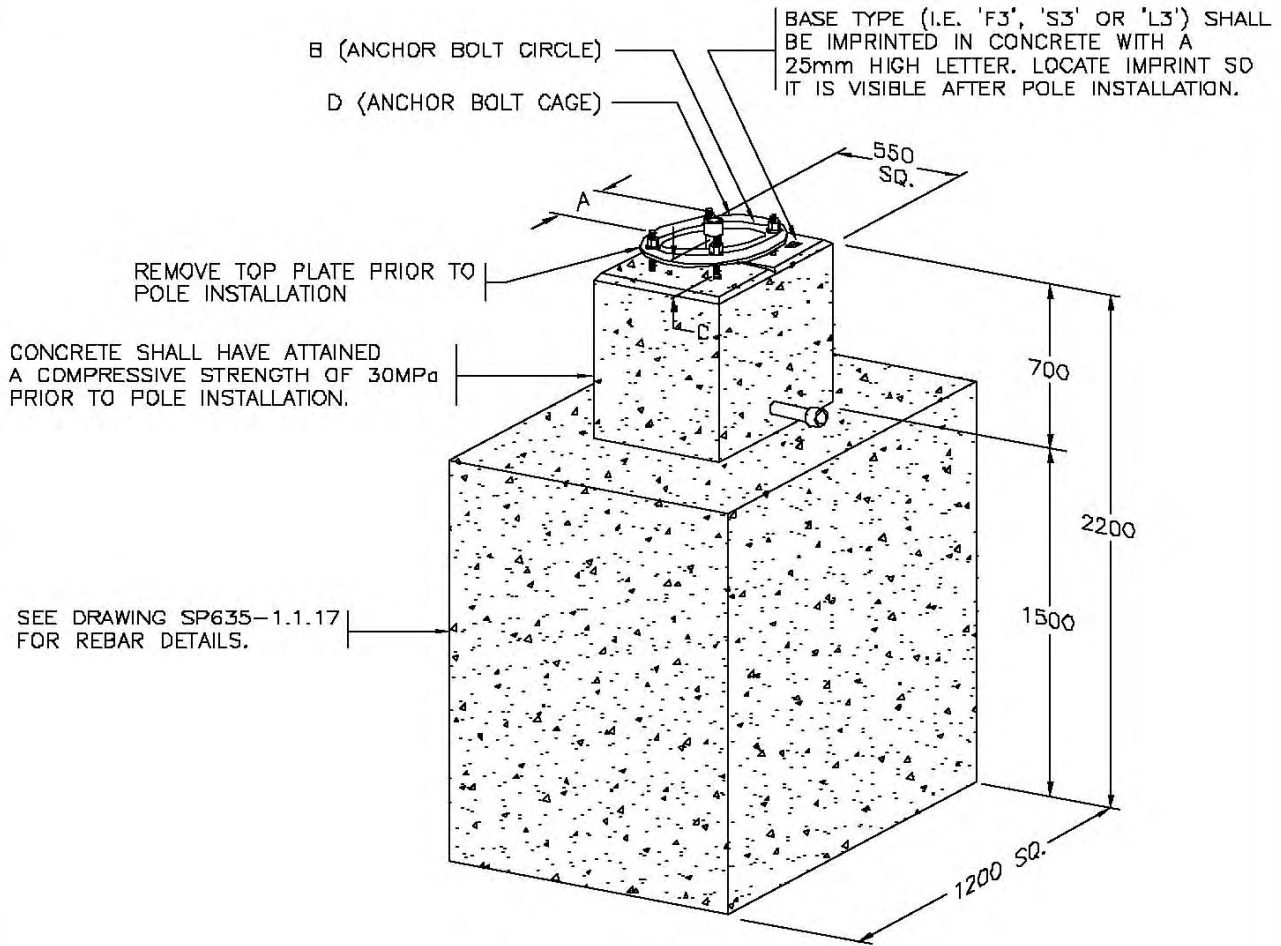

POURED IN PLACE CONCRETE BASES

BASE TYPE	POLE TYPE	APPROXIMATE MASS	VOLUME OF CONCRETE	A	B	C	D (ANCHOR BOLTS)
F3	TYPE 6 AND 7 SHAFTS	5925 kg	2.37m ³	243	343	160	4-1"φ x 48" (1220) GALVANIZED GRADE 150 DYWIDAG BOLTS PRE-ASSEMBLED IN A CAGE (SN1841A)
S3	TYPE S POLES	5925 kg	2.37m ³	243	343	160	4-1"φ x 48" (1220) GALVANIZED GRADE 150 DYWIDAG BOLTS PRE-ASSEMBLED IN A CAGE (SN1841A)
L3	TYPE L POLES	5965 kg	2.37m ³	276	390	140	4-1 1/2"φ x 54" (1370) GALVANIZED AISI / SAE 4140 BOLTS PRE-ASSEMBLED IN A CAGE (SN1839L)

NOTES

- SEE STANDARD SPECIFICATIONS & SPECIAL PROVISIONS FOR ADDITIONAL INFORMATION.
- 'SN' DENOTES MINISTRY STOCK NUMBER.
- ALL DIMENSIONS ARE IN MILLIMETRES UNLESS OTHERWISE NOTED.
- SEE DRAWING SP635-1.1.17 FOR ADDITIONAL DETAILS.
- SEE DRAWINGS SP635-1.4.1 TO 1.4.4 FOR BACKFILL REQUIREMENTS.

NOT TO SCALE



No.	Revision	Date	TYPE F3, L3 & S3 CONCRETE BASES (POURED IN PLACE)		SPECIFICATION DRAWING No.
F			Date	Approved	30/09/93 E.L. (Signature on File) Chief Highway Engineer
E					
D					
C	TYPE S3 BASE ADDED	OCT 03			
B	DRAWING NUMBER CHANGED	AUG 95			
A	GENERAL REVISIONS	AUG 94			SP635-1.1.16

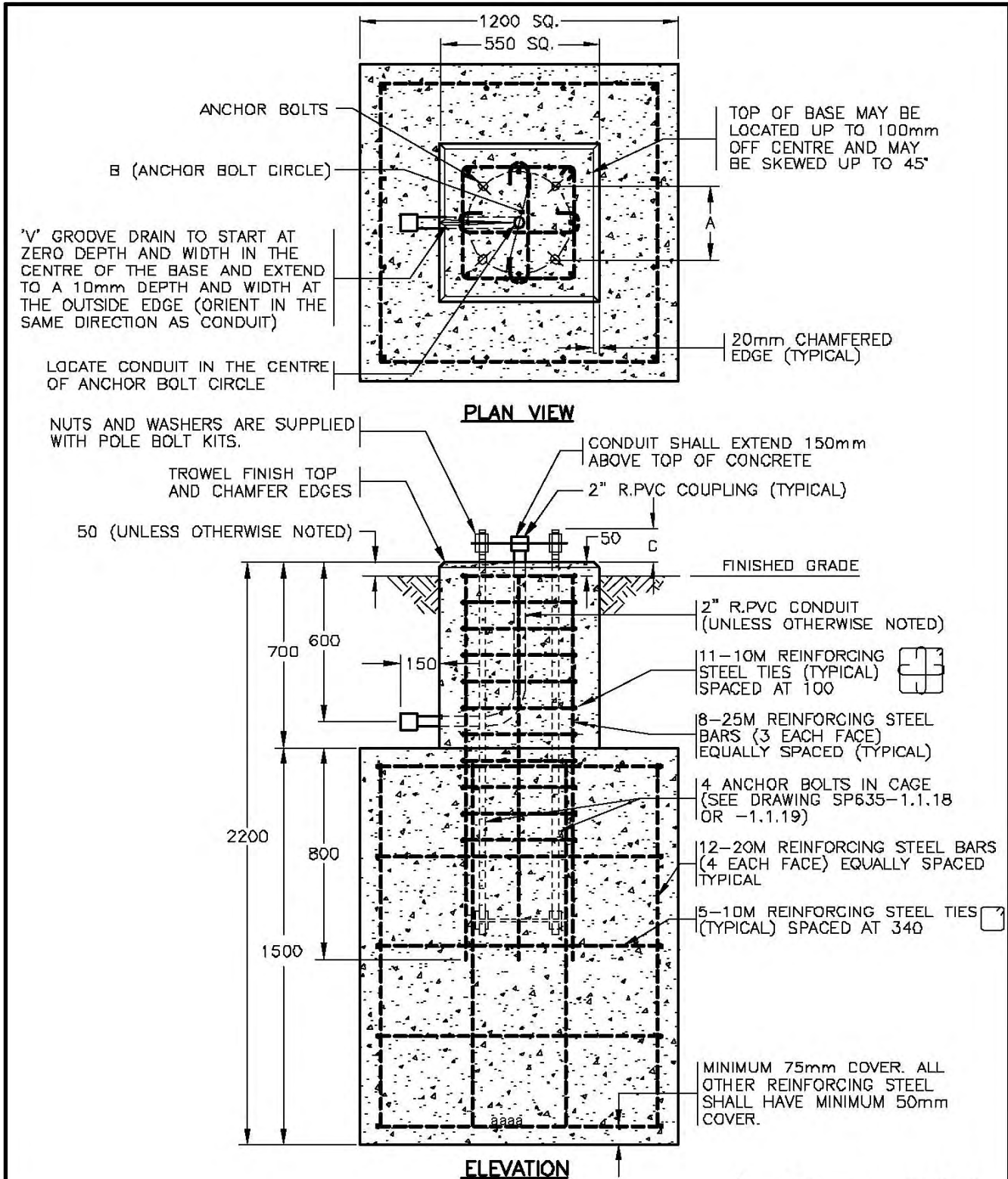

SEE DRAWING SP635-1.1.16 FOR NOTES AND ADDITIONAL DETAILS



NOT TO SCALE

No.	Revision	Date	TYPE F3, L3 & S3 CONCRETE BASES (POURED IN PLACE)		SPECIFICATION DRAWING No. SP635-1.1.17
F			Date	Approved	
E			30/09/93	E.L. (Signature on File) Chief Highway Engineer	
D	TYPE S3 BASE ADDED	OCT 03			
C	ELEVATION OF BASE TO FINISHED GRADE REVISED	AUG 96			
B	NECK WIDTH REVISED & REBAR ADDED	AUG 95			
A	GENERAL REVISIONS	AUG 94			

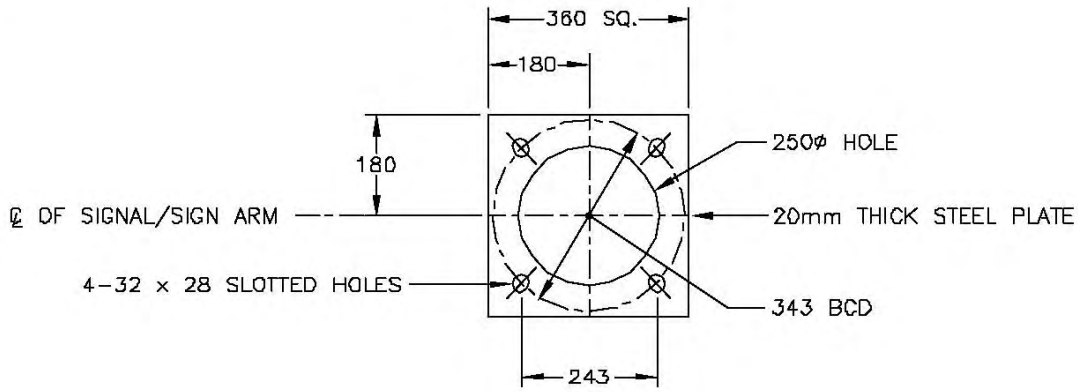

TOP AND BOTTOM PLATES

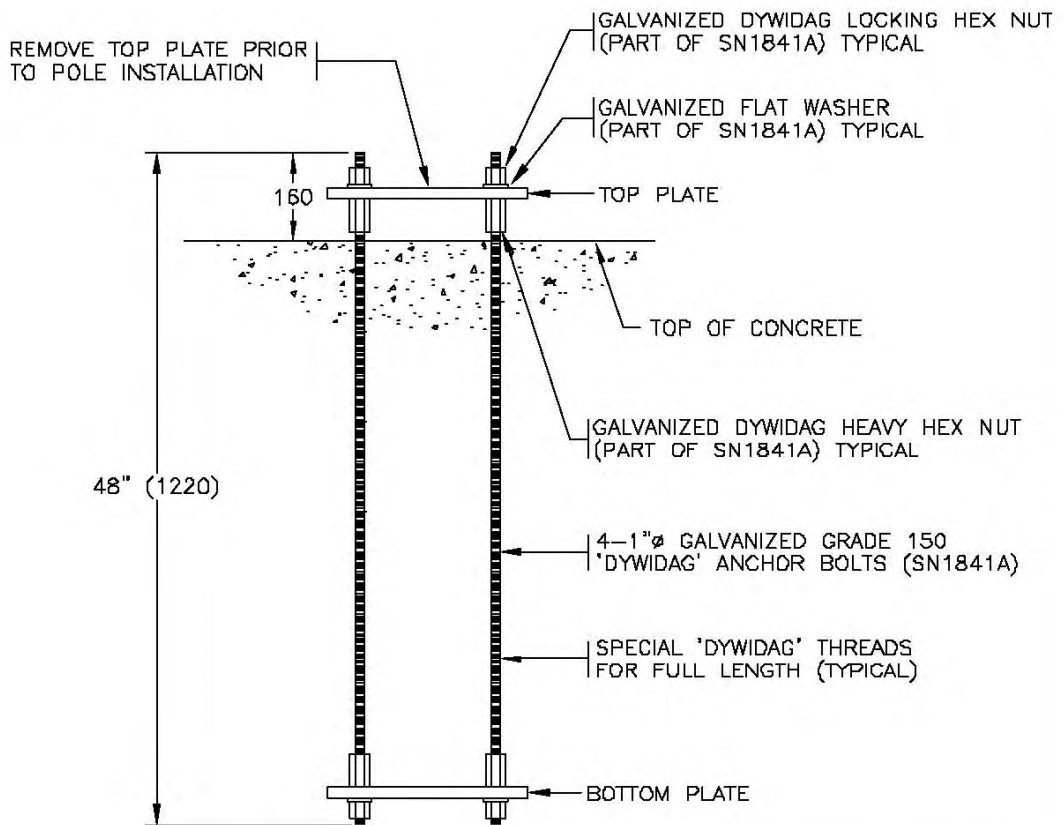

ANCHOR BOLT CAGE

SN1841A
aaaa

APPROXIMATE MASS
60 kg

SEE DRAWINGS SP635-1.1.11, 1.1.14 AND 1.1.16 FOR NOTES AND ADDITIONAL DETAILS



NOT TO SCALE

No.	Revision	Date
F		
E		
D		
C	TYPE S POLE ADDED & TOP PLATE NOTE REVISED	OCT 03
B	HOLE SIZE IN PLATE ADDED	AUG 95
A	GENERAL REVISIONS	AUG 94

**ANCHOR BOLT CAGE
FOR TYPE 6, 7 & S SHAFTS**

Date Approved
30/09/93 E.L. (Signature on File)
Chief Highway Engineer

SPECIFICATION
DRAWING No.
SP635-1.1.18

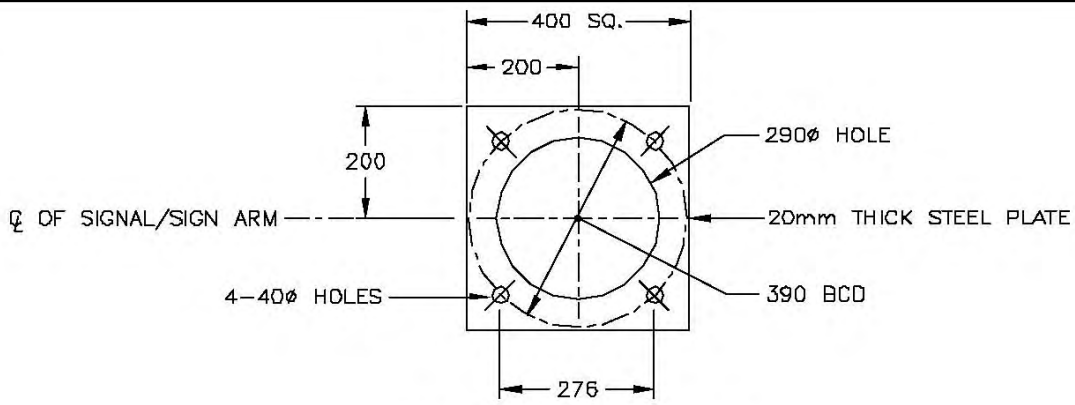

TOP AND BOTTOM PLATES

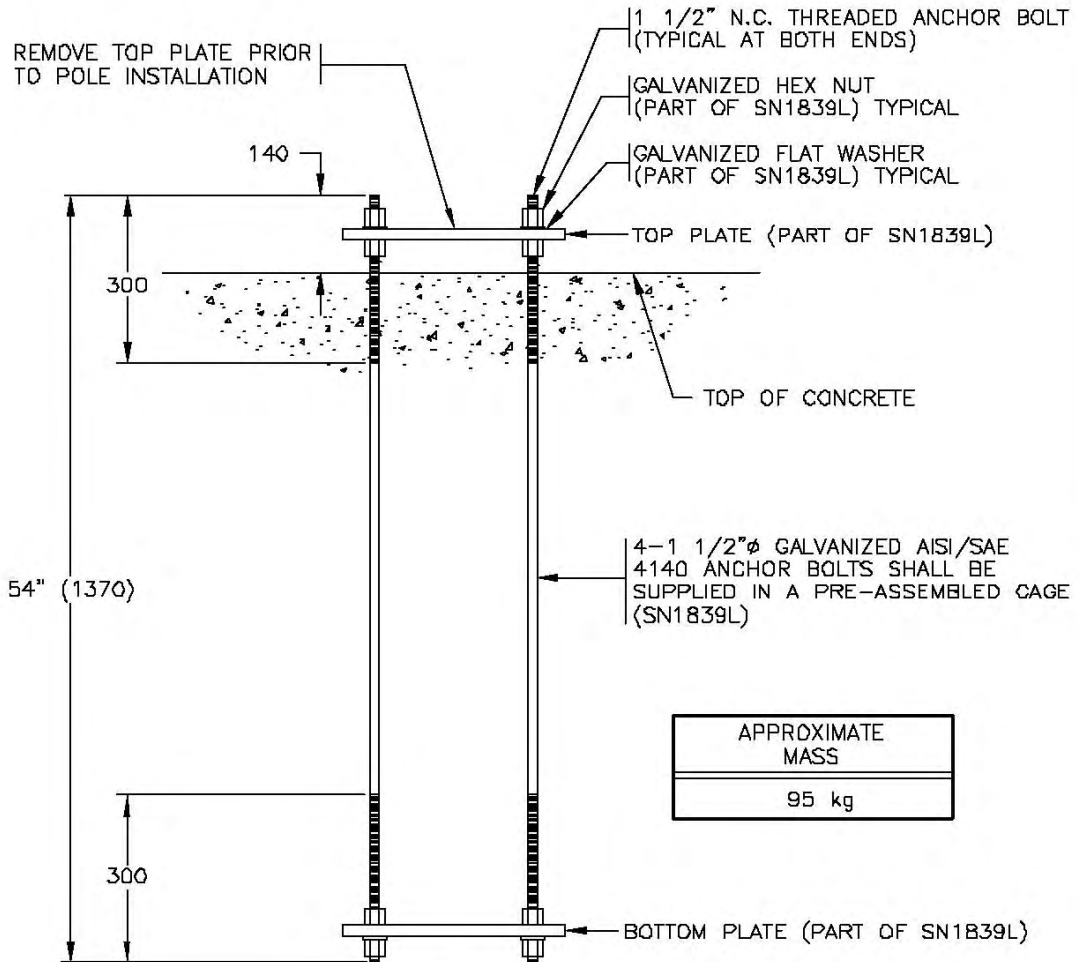

ANCHOR BOLT CAGE
SN1839L

SEE DRAWINGS SP635-1.1.11, 1.1.14 AND 1.1.16 FOR NOTES AND ADDITIONAL DETAILS



NOT TO SCALE

No.	Revision	Date
F		
E		
D		
C	TOP PLATE NOTE REVISED	OCT 03
B	HOLE SIZE IN PLATE REVISED	AUG 95
A	GENERAL REVISIONS	AUG 94

ANCHOR BOLT CAGE FOR TYPE L POLES	
Date	Approved
30/09/93	E.L. (Signature on File) Chief Highway Engineer

SPECIFICATION DRAWING No.
SP635-1.1.19

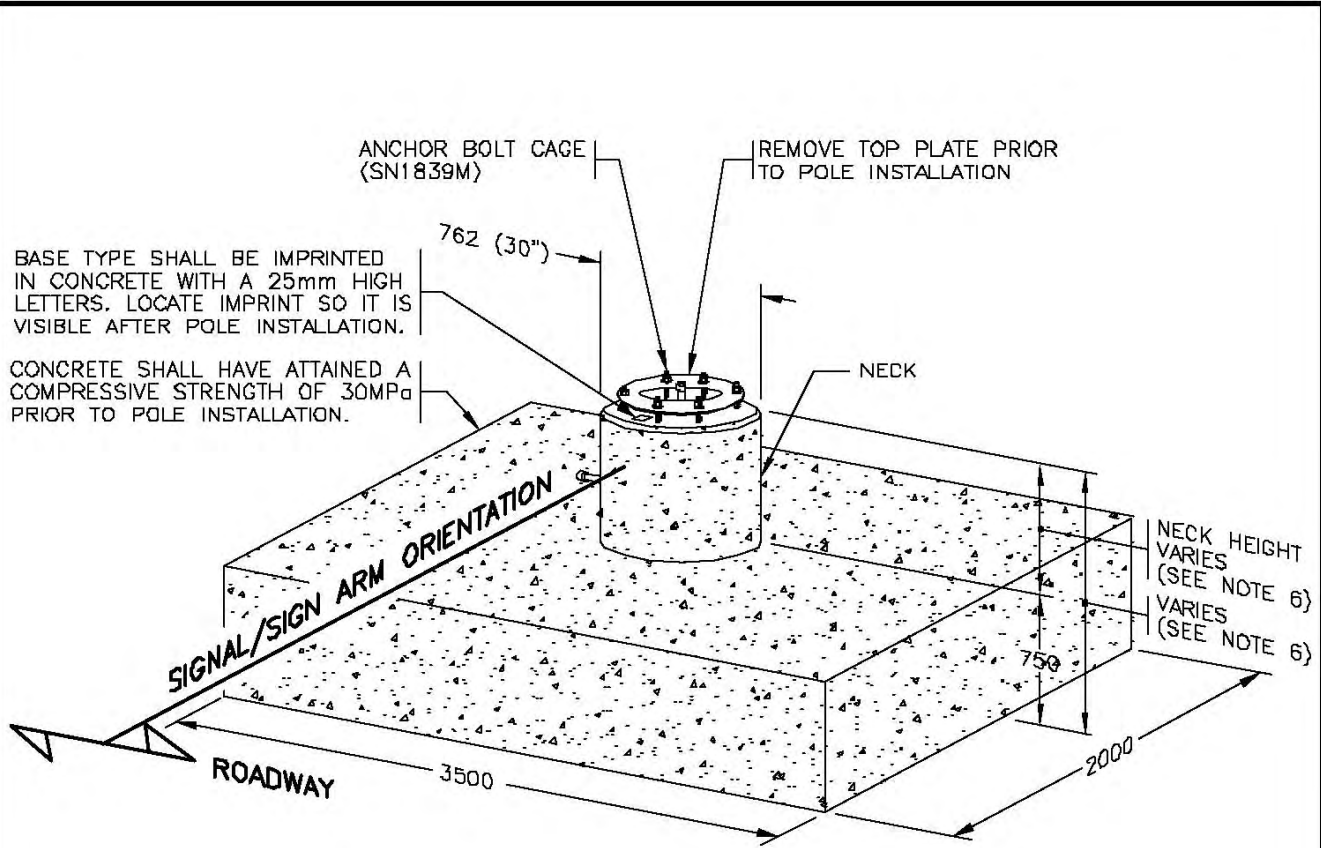

CONCRETE SPREAD FOOTING

BASE TYPE	POLE TYPE	VOLUME OF CONCRETE	MASS OF REBAR	FORMWORK	APPROXIMATE MASS
M1	TYPE M POLES	5.90 m ³ *	540 kg *	11.6 m ² *	14400 kg *

(*) BASED ON SPREAD FOOTING WITH 1400 HIGH NECK

NOTES

- SEE STANDARD SPECIFICATIONS & SPECIAL PROVISIONS FOR ADDITIONAL INFORMATION.
- SEE PLANS FOR SIGNAL/SIGN ARM ORIENTATION.
- 'SN' DENOTES MINISTRY STOCK NUMBER.
- SEE DRAWINGS SP635-1.1.21, 1.1.22 & 1.4.5 FOR ADDITIONAL DETAILS.
- ALL DIMENSIONS ARE IN MILLIMETRES UNLESS OTHERWISE NOTED. aaaa
- NECK HEIGHT MAY VARY FROM 750 TO 2000. SEE DRAWING SP635-1.4.5 FOR MORE INFORMATION.

BASE DESIGNED FOR SOILS WITH A MINIMUM BEARING PRESSURE OF 100KPa



NOT TO SCALE

No.	Revision	Date	TYPE M1 CONCRETE SPREAD FOOTING (POURED IN PLACE)	
F			Date	Approved
E			30/09/93	E.L. (Signature on File)
D			SPECIFICATION DRAWING No. SP635-1.1.20	
C	NECK HEIGHT REVISED	AUG 96	Chief Highway Engineer	
B	NECK HEIGHT REVISED & REBAR ADDED	AUG 95		
A	GENERAL REVISIONS	AUG 94		

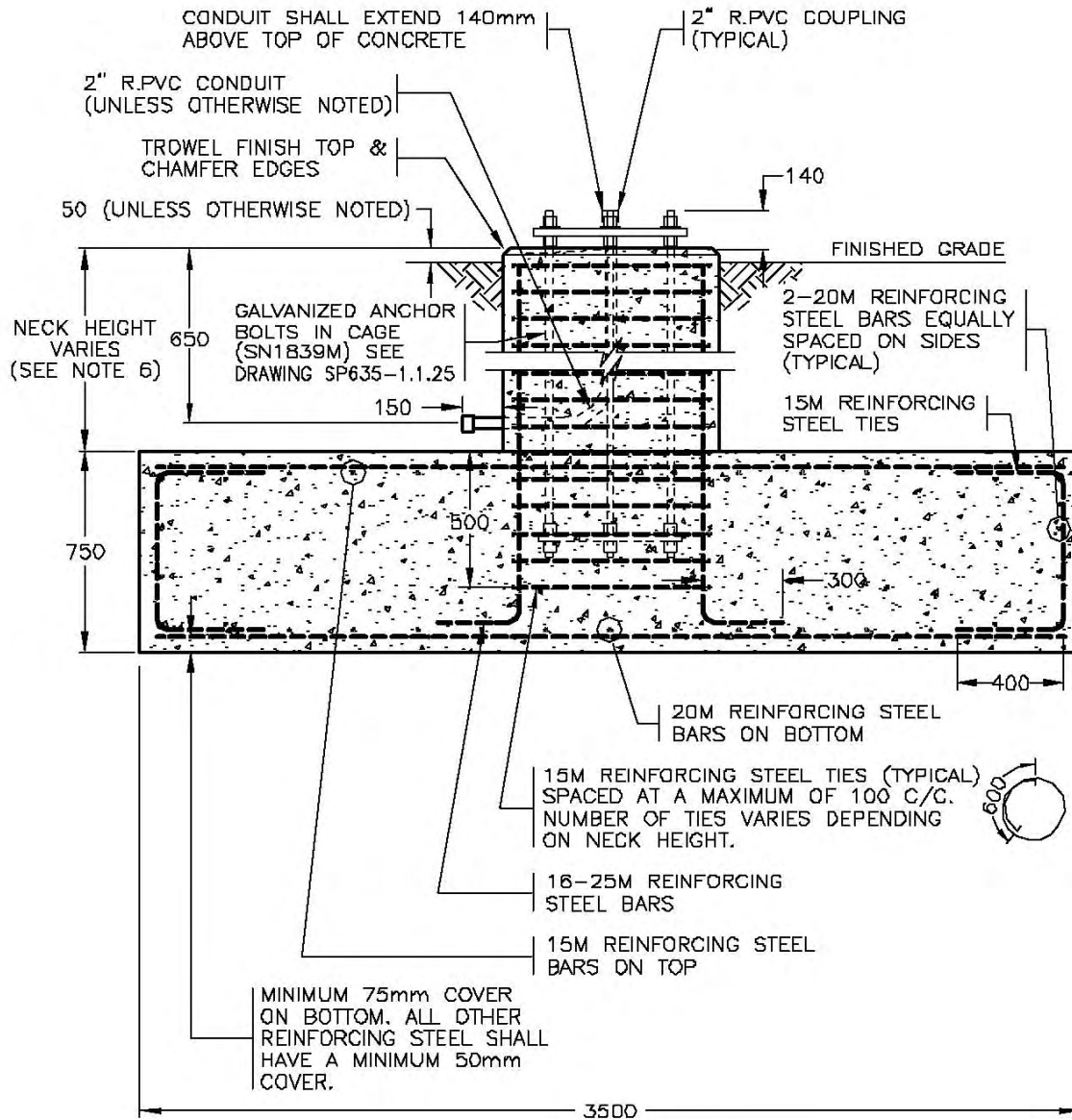

ELEVATION

aaaa

SEE DRAWING SP635-1.1.20 FOR NOTES AND ADDITIONAL DETAILS



NOT TO SCALE

No.	Revision	Date
F		
E		
D		
C	REBAR IN NECK & BASE ELEVATION REVISED	AUG 96
B	NECK HEIGHT REVISED & REBAR ADDED	AUG 95
A	GENERAL REVISIONS	AUG 94

**TYPE M1 CONCRETE SPREAD FOOTING
(POURED IN PLACE)**

Date: **30/09/93** Approved: **E.L. (Signature on File)**
Chief Highway Engineer

SPECIFICATION
DRAWING No.
SP635-1.1.21

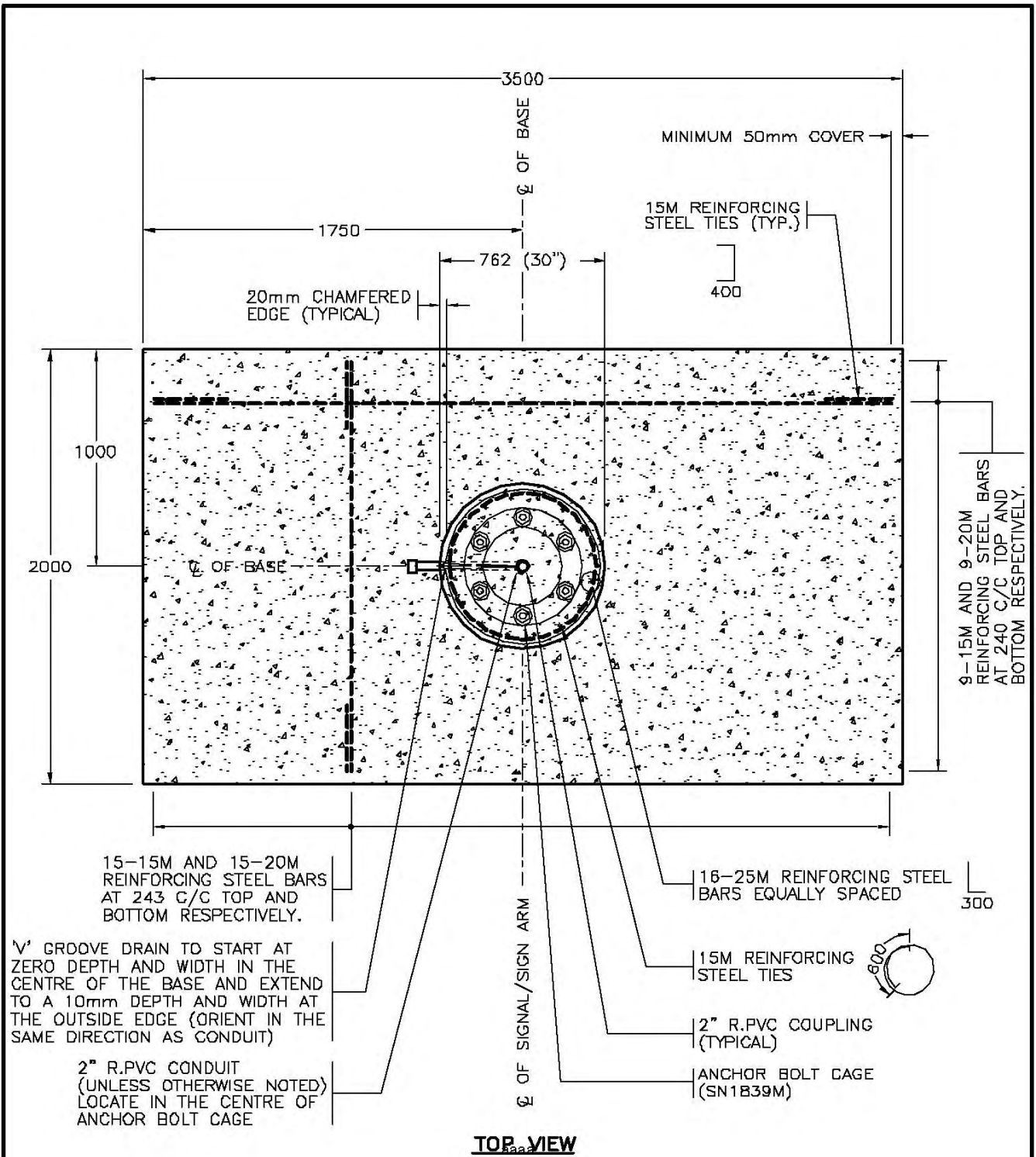

TOP VIEW

SEE DRAWING SP635-1.1.20 FOR NOTES AND ADDITIONAL DETAILS



NOT TO SCALE

No.	Revision	Date
F		
E		
D		
C		
B	LENGTH REVISED & REBAR ADDED	AUG 95
A	GENERAL REVISIONS	AUG 94

**TYPE M1 CONCRETE SPREAD FOOTING
(POURED IN PLACE)**

Date: **30/09/93** Approved: **E.L. (Signature on File)**
Chief Highway Engineer

SPECIFICATION
DRAWING No.
SP635-1.1.22

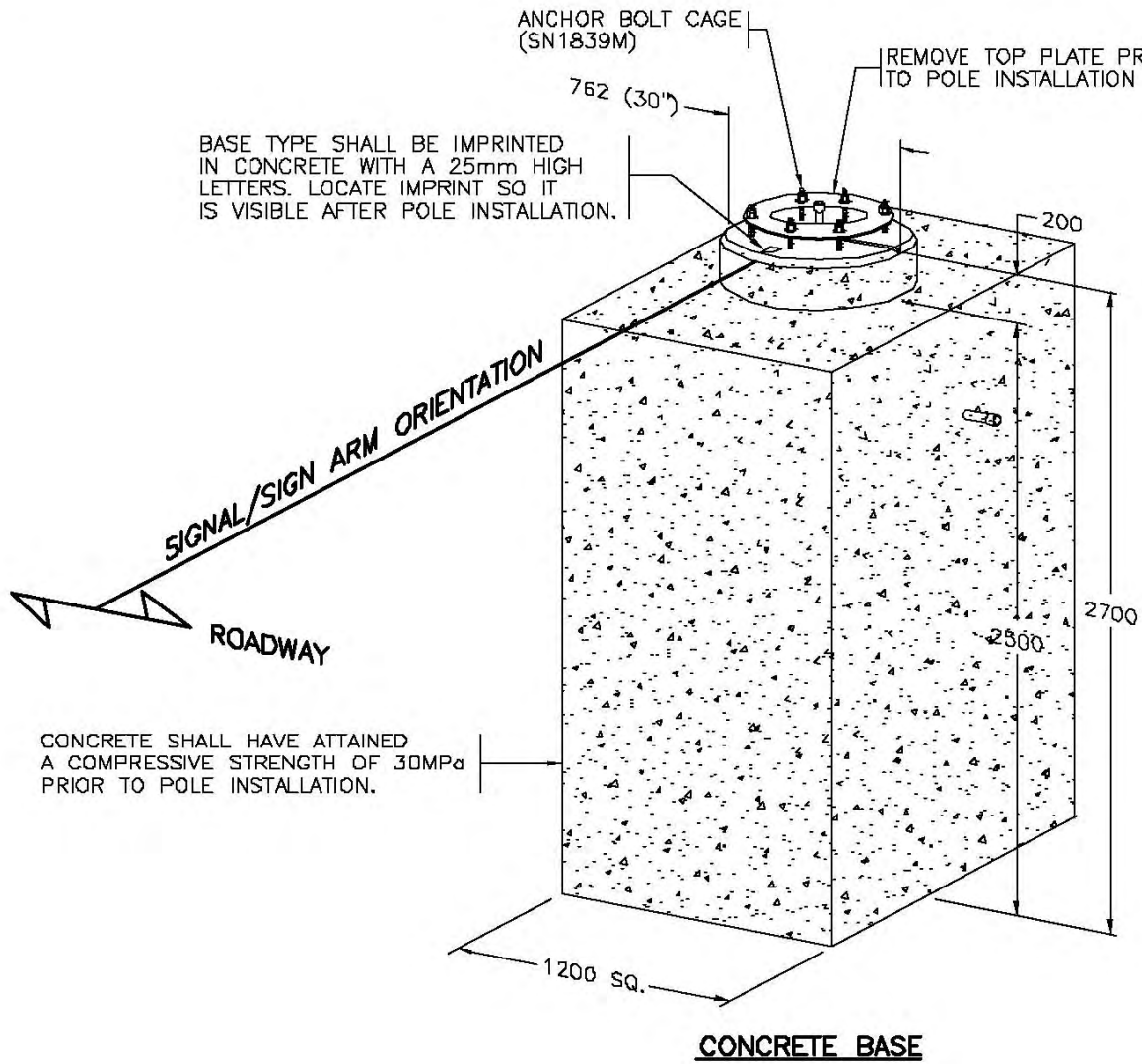

BASE TYPE	POLE TYPE	VOLUME OF CONCRETE	MASS OF REBAR	FORMWORK	APPROXIMATE MASS
M2	TYPE M POLES	3.7 m ³	100 kg	12.5 m ²	8935 kg

NOTES

1. SEE STANDARD SPECIFICATIONS & SPECIAL PROVISIONS FOR ADDITIONAL INFORMATION.
2. SEE PLANS FOR SIGNAL/SIGN ARM ORIENTATION.
3. 'SN' DENOTES MINISTRY STOCK NUMBER.
4. SEE DRAWINGS SP635-1.1.24 & 1.4.1 TO 1.4.4 FOR ADDITIONAL DETAILS.
5. ALL DIMENSIONS ARE IN MILLIMETRES UNLESS OTHERWISE NOTED.
6. SEE DRAWINGS SP635-1.4.1 TO 1.4.4 FOR BACKFILL REQUIREMENTS.

aaaa



NOT TO SCALE

No.	Revision	Date	TYPE M2 CONCRETE BASE (POURED IN PLACE)		SPECIFICATION DRAWING No.
F			Date	Approved	30/09/93 E.L. (Signature on File) Chief Highway Engineer SP635-1.1.23
E					
D					
C	NOTE 4 REVISED	AUG 96			
B	NOTE 4 REVISED	AUG 95			
A	GENERAL REVISIONS	AUG 94			

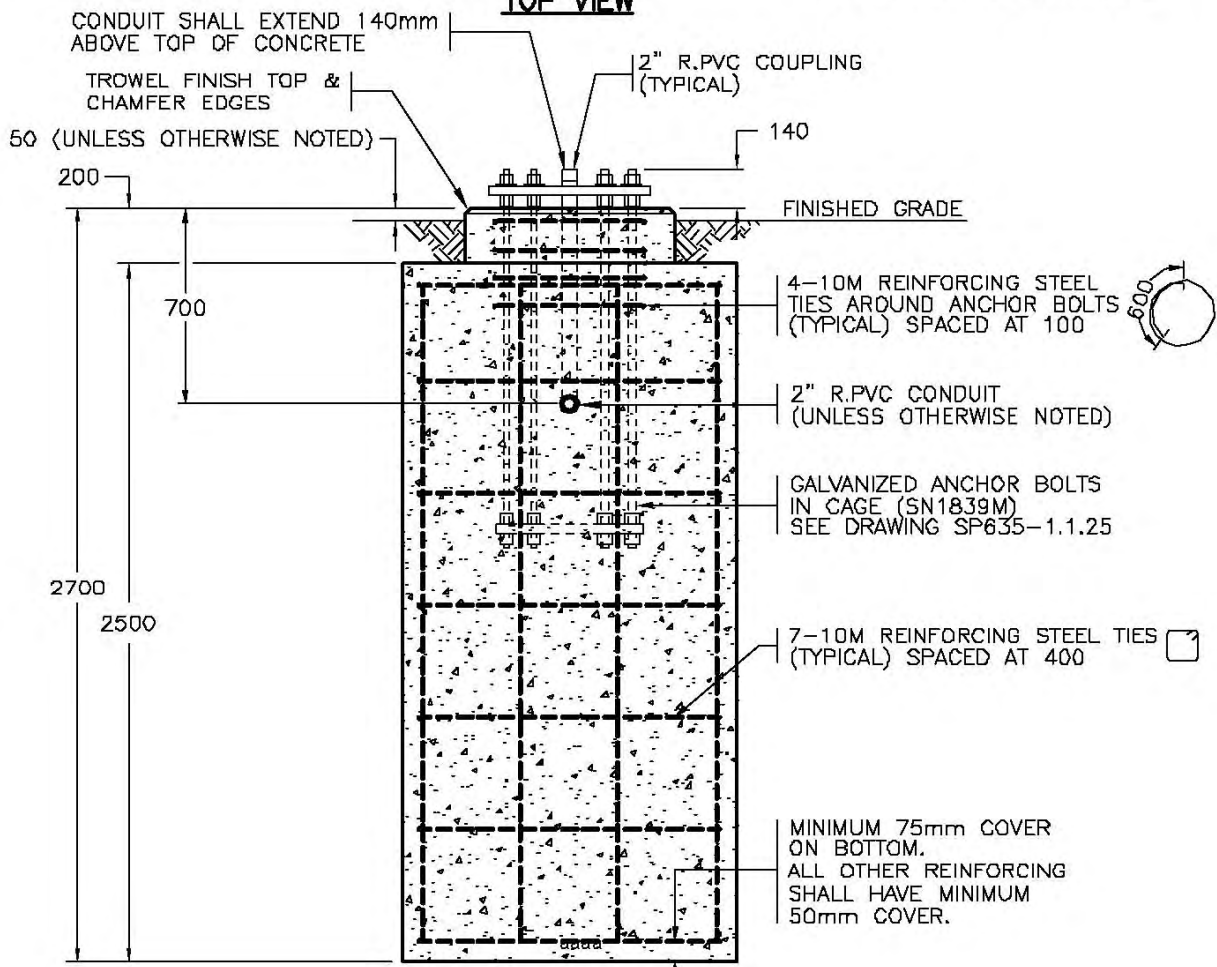
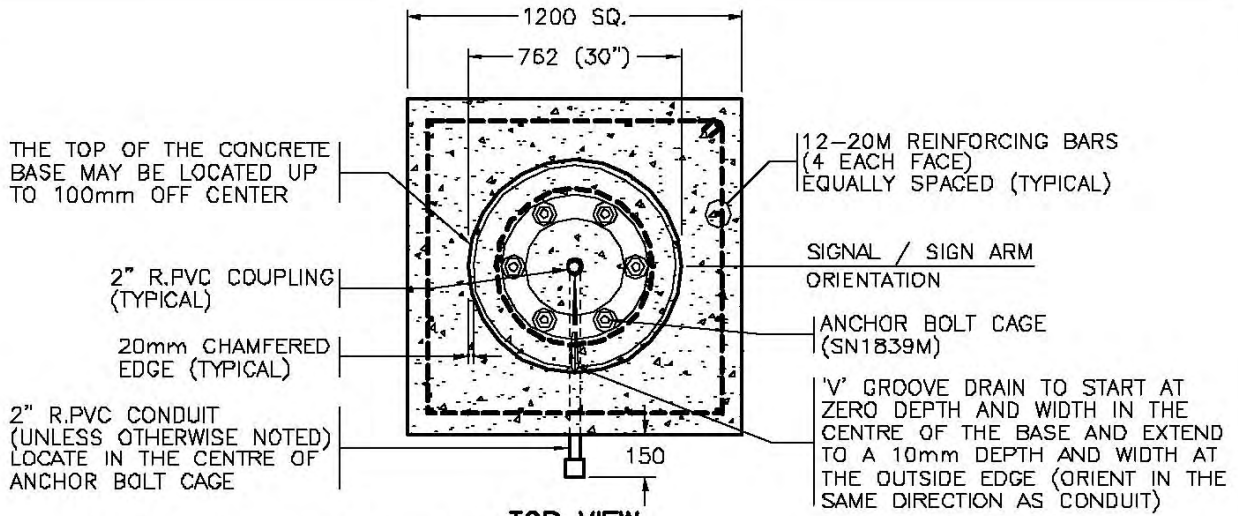

SEE DRAWING SP635-1.1.23 FOR NOTES AND ADDITIONAL DETAILS



NOT TO SCALE

No.	Revision	Date
F		
E		
D		
C	ELEVATION OF BASE TO FINISHED GRADE REVISED	AUG 96
B	DRAWING REFERENCE CHANGED	AUG 95
A	GENERAL REVISIONS	AUG 94

**TYPE M2 CONCRETE BASE
(PRECAST OR Poured IN PLACE)**

Date	Approved	SPECIFICATION
30/09/93	E.L. (Signature on File)	DRAWING No.
Chief Highway Engineer		SP635-1.1.24

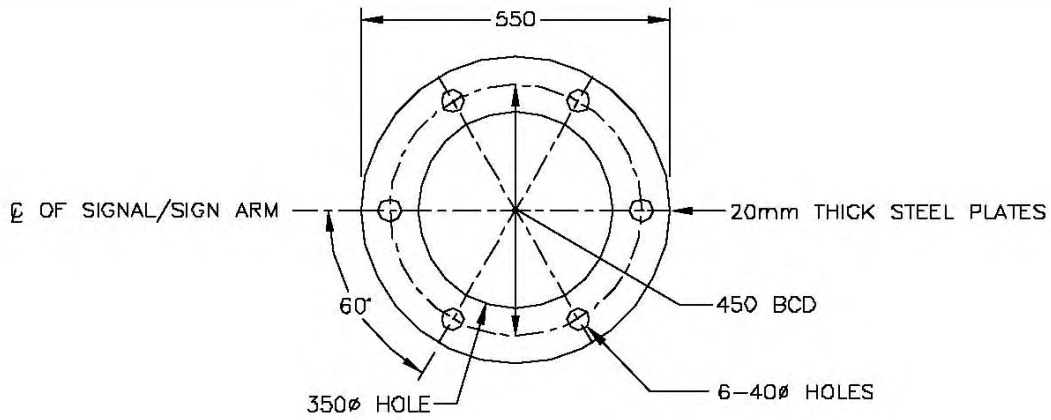

TOP AND BOTTOM PLATES

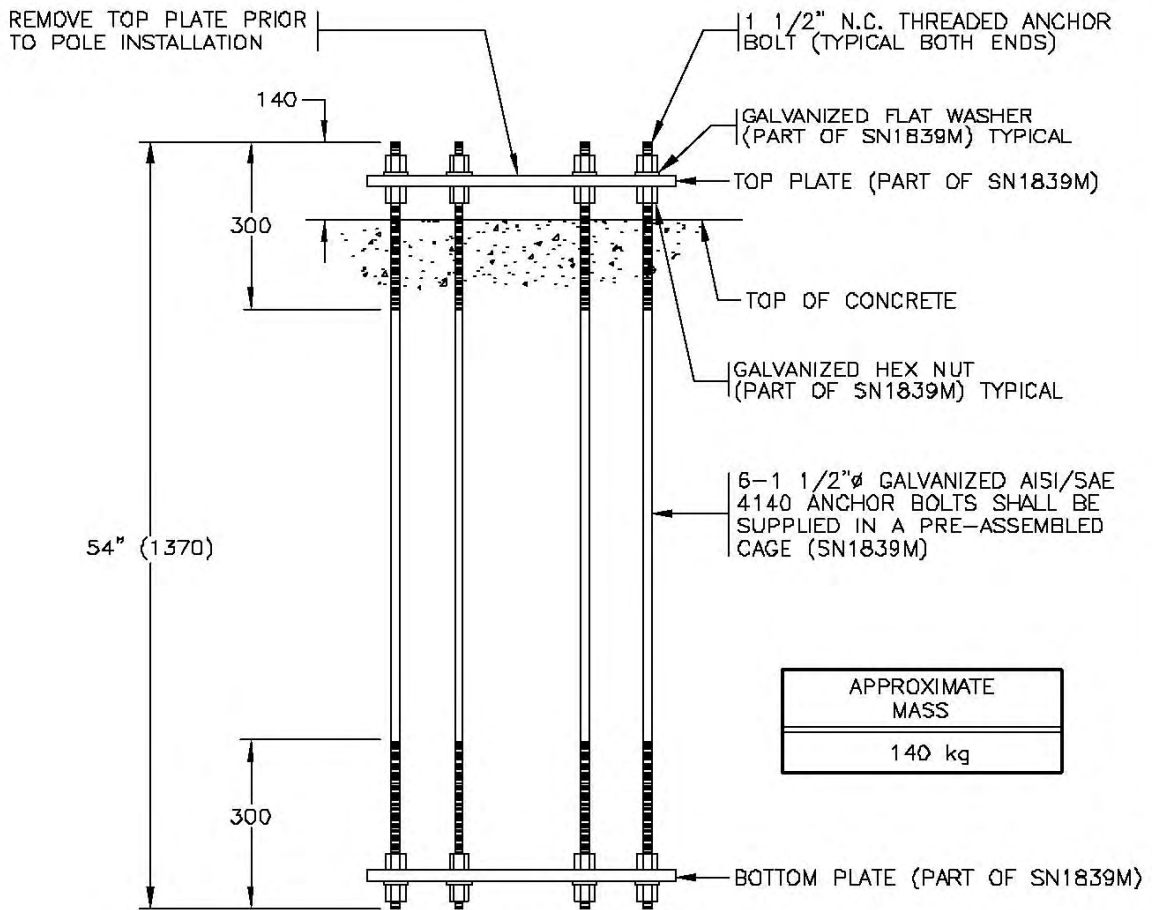

ANCHOR BOLT CAGE
SN1839M

SEE DRAWINGS SP635-1.1.20 AND 1.1.23 FOR NOTES AND ADDITIONAL DETAILS

NOT TO SCALE



No.	Revision	Date
F		
E		
D		
C	TOP PLATE NOTE REVISED	OCT 03
B	HOLE SIZE IN PLATE REVISED	AUG 95
A	GENERAL REVISIONS	AUG 94

ANCHOR BOLT CAGE FOR TYPE M POLES		SPECIFICATION DRAWING No.
Date	Approved	SP635-1.1.25
30/09/93	E.L. (Signature on File) Chief Highway Engineer	

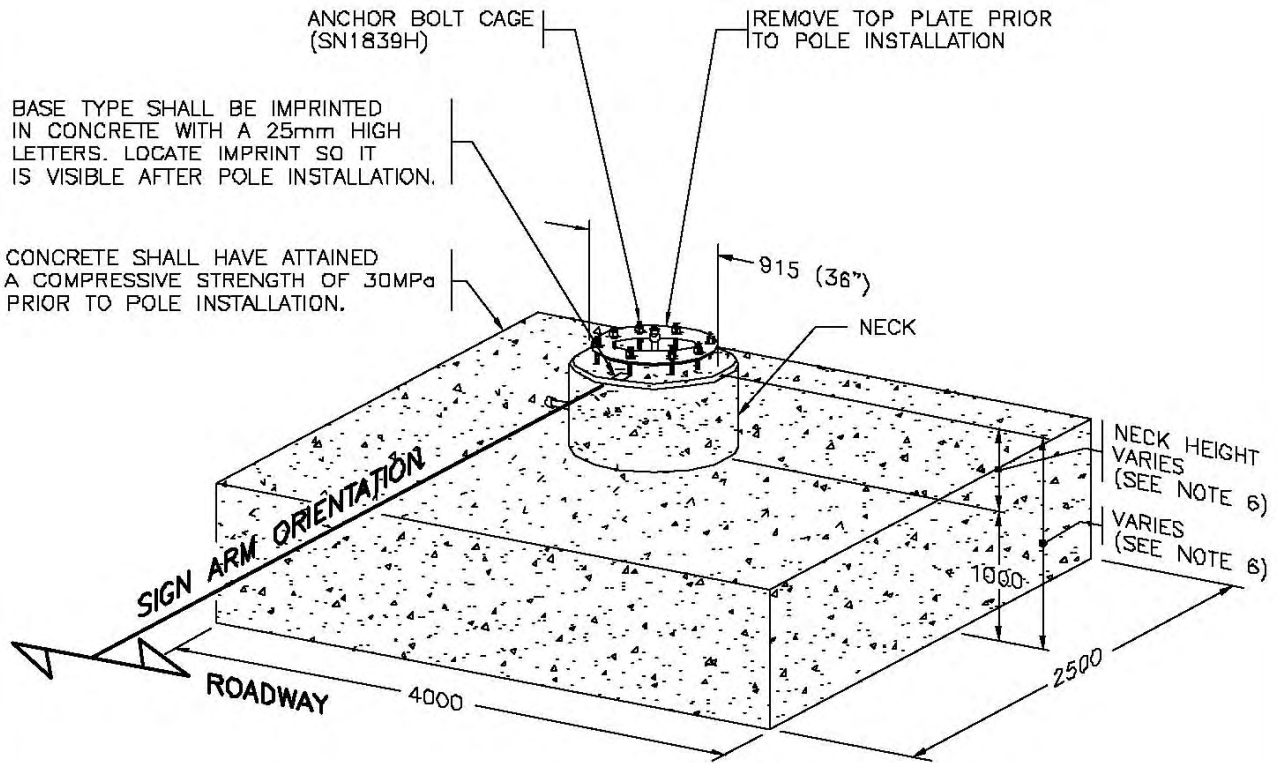

CONCRETE SPREAD FOOTING

BASE TYPE	POLE TYPE	VOLUME OF CONCRETE	MASS OF REBAR	FORMWORK	APPROXIMATE MASS
H1	TYPE H POLES	10.9 m ³ *	760 kg *	17.0 m ² *	26700 kg *

(*) BASED ON SPREAD FOOTING WITH 1400 HIGH NECK

NOTES

- SEE STANDARD SPECIFICATIONS & SPECIAL PROVISIONS FOR ADDITIONAL INFORMATION.
- SEE PLANS FOR SIGN ARM ORIENTATION.
- 'SN' DENOTES MINISTRY STOCK NUMBER.
- SEE DRAWINGS SP635-1.1.27, 1.1.28 & 1.4.5 FOR ADDITIONAL DETAILS.
- ALL DIMENSIONS ARE IN MILLIMETRES UNLESS OTHERWISE NOTED. aaaa
- NECK HEIGHT MAY VARY FROM 750 TO 2500. SEE DRAWING SP635-1.4.5 FOR MORE INFORMATION.

BASE DESIGNED FOR SOILS WITH A MINIMUM BEARING PRESSURE OF 100KPa



NOT TO SCALE

No.	Revision	Date
F		
E		
D		
C	NECK HEIGHT REVISED	AUG 96
B	NECK HEIGHT REVISED & REBAR ADDED	AUG 95
A	GENERAL REVISIONS	AUG 94

TYPE H1 CONCRETE SPREAD FOOTING (POURED IN PLACE)		
Date	Approved	SPECIFICATION DRAWING No.
30/09/93	E.L. (Signature on File) Chief Highway Engineer	SP635-1.1.26

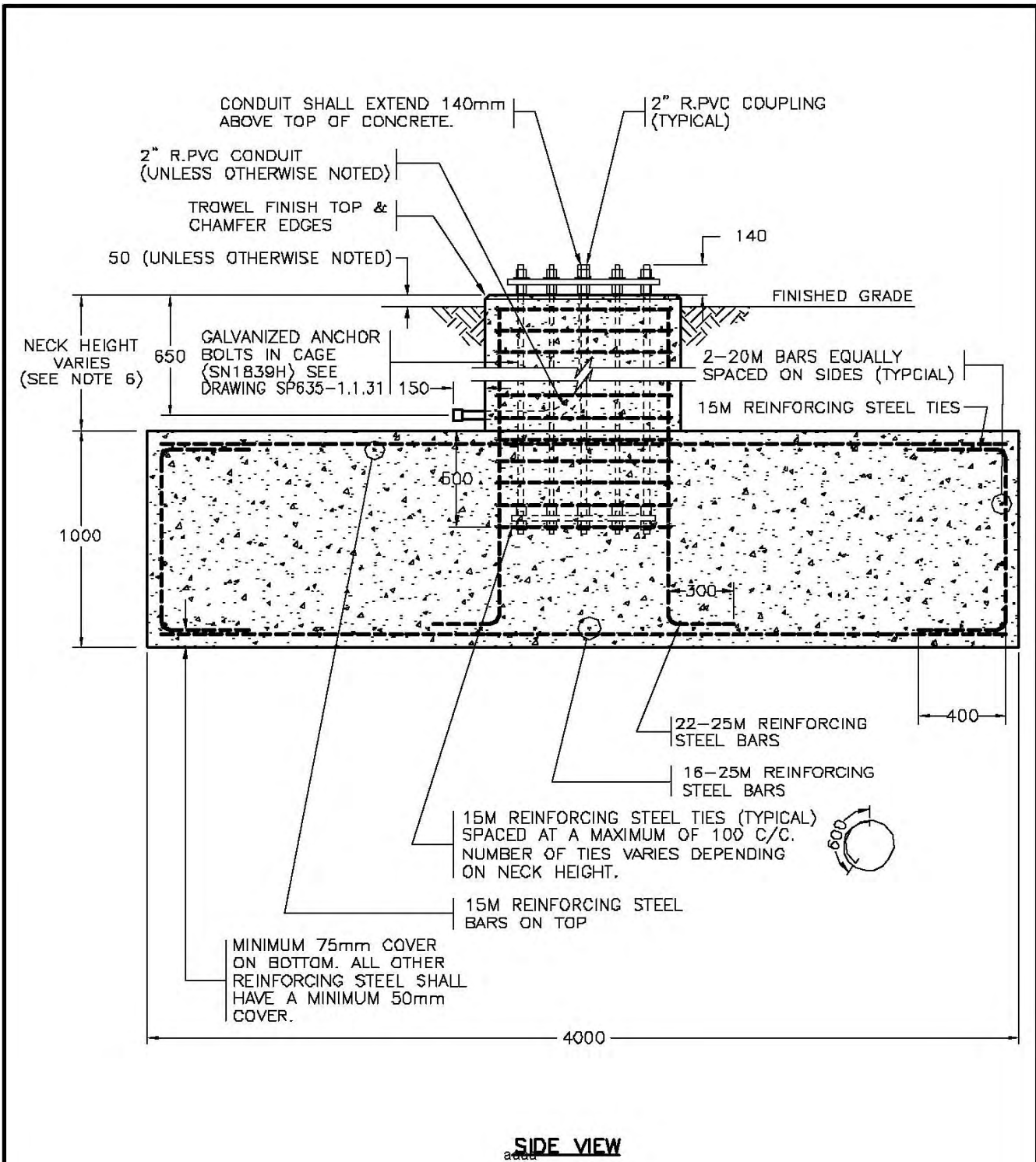

SEE DRAWING SP635-1.1.26 FOR NOTES AND ADDITIONAL DETAILS



NOT TO SCALE

No.	Revision	Date	TYPE H1 CONCRETE SPREAD FOOTING (POURED IN PLACE)		SPECIFICATION DRAWING No. SP635-1.1.27
F			Date	Approved	
E			30/09/93	E.L. (Signature on File) Chief Highway Engineer	
D					
C	REBAR IN NECK & BASE ELEVATION REVISED	AUG 96			
B	NECK HEIGHT REVISED & REBAR ADDED	AUG 95			
A	GENERAL REVISIONS	AUG 94			

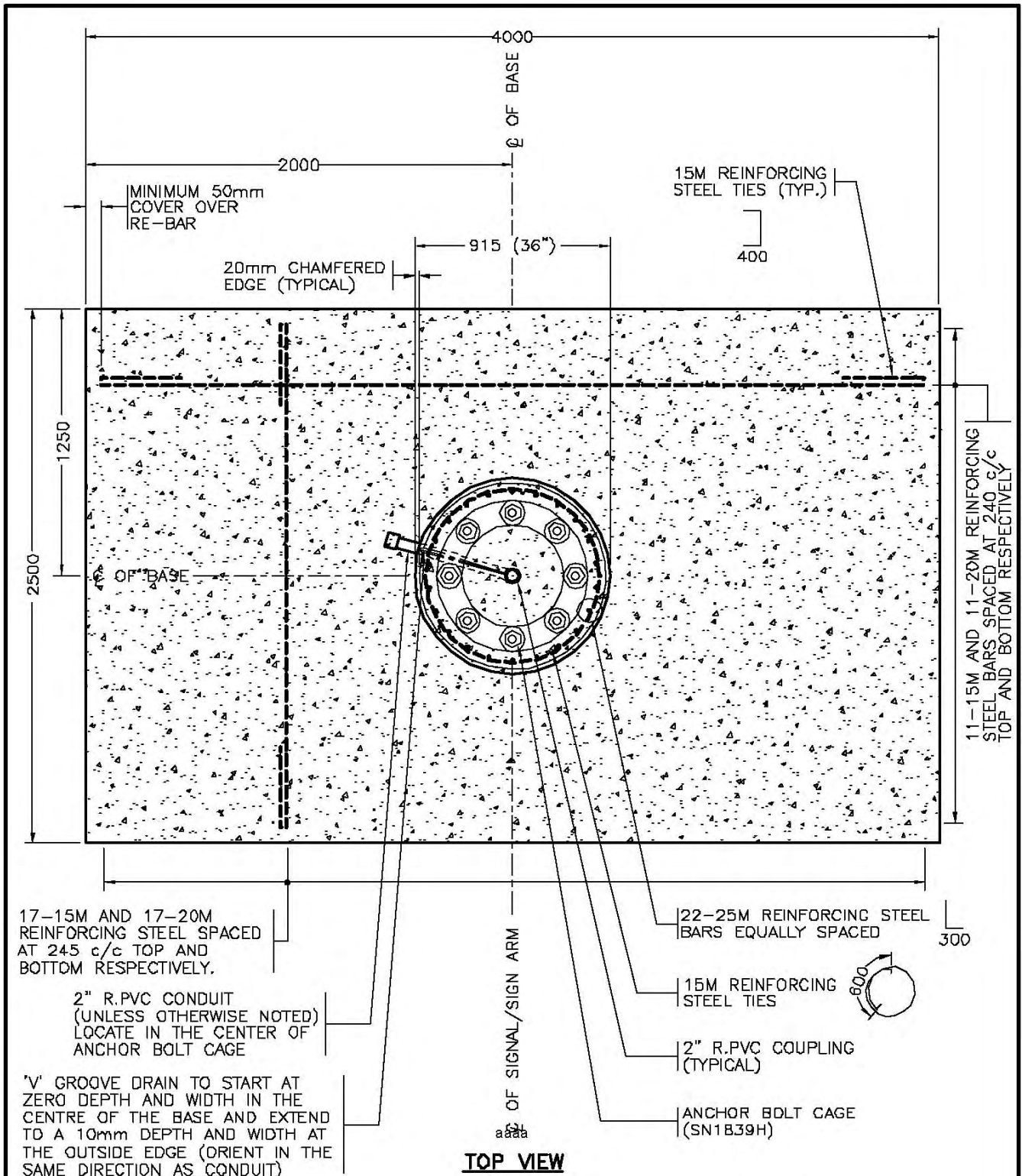

SEE DRAWING SP635-1.1.26 FOR NOTES AND ADDITIONAL DETAILS



NOT TO SCALE

No.	Revision	Date
F		
E		
D		
C		
B	REBAR ADDED	AUG 95
A	GENERAL REVISIONS	AUG 94

**TYPE H1 CONCRETE SPREAD FOOTING
(POURED IN PLACE)**

Date	Approved	SPECIFICATION DRAWING No.
30/09/93	E.L. (Signature on File) Chief Highway Engineer	SP635-1.1.28

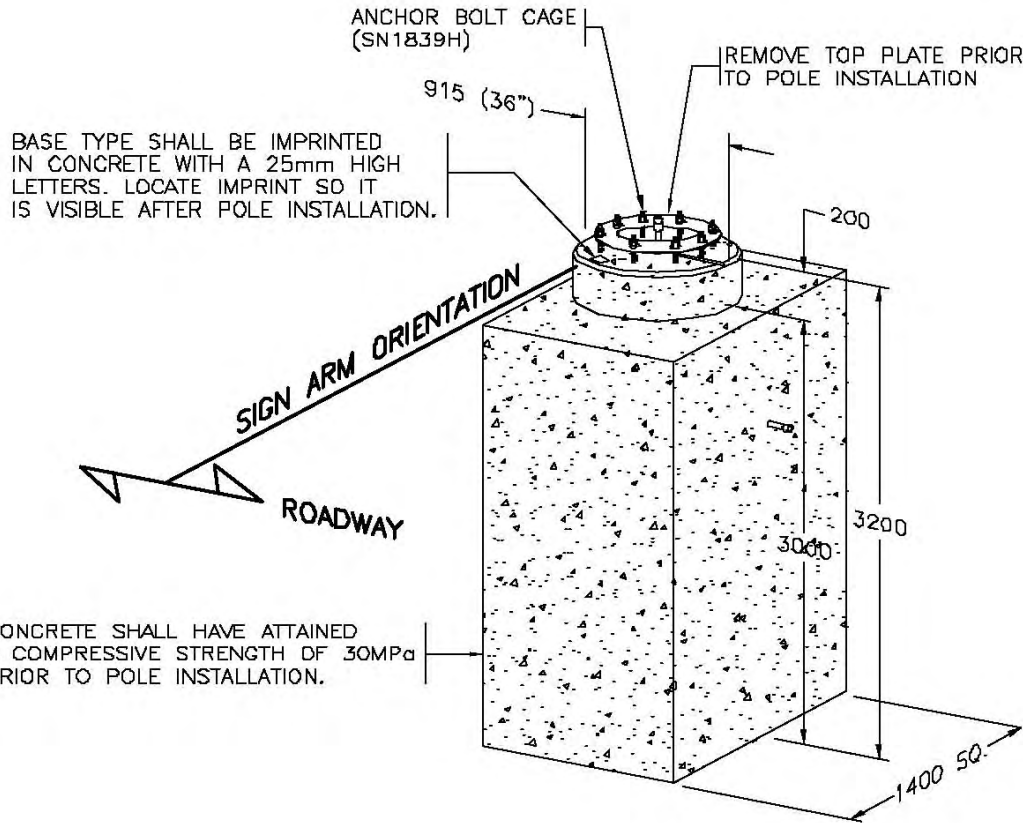

CONCRETE BASE

BASE TYPE	POLE TYPE	VOLUME OF CONCRETE	MASS OF REBAR	FORMWORK	APPROXIMATE MASS
H2	TYPE H POLES	6.0 m ³	155 kg	17.4 m ²	14445 kg

NOTES

1. SEE STANDARD SPECIFICATIONS & SPECIAL PROVISIONS FOR ADDITIONAL INFORMATION.
2. SEE PLANS FOR SIGN ARM ORIENTATION.
3. 'SN' DENOTES MINISTRY STOCK NUMBER.
4. SEE DRAWINGS SP635-1.1.30 & 1.4.1 to 1.4.3 FOR ADDITIONAL DETAILS. aaaa
5. ALL DIMENSIONS ARE IN MILLIMETRES UNLESS OTHERWISE NOTED.
6. SEE DRAWINGS SP635-1.4.1 TO 1.4.4 FOR BACKFILL REQUIREMENTS.

NOT TO SCALE



No.	Revision	Date	TYPE H2 CONCRETE BASE (PRECAST OR Poured IN PLACE)	
F			Date	Approved
E			30/09/93	E.L. (Signature on File)
D			SPECIFICATION DRAWING No. SP635-1.1.29	
C	NOTE 4 REVISED	AUG 96	Chief Highway Engineer	
B	NOTE 4 REVISED	AUG 95		
A	GENERAL REVISIONS	AUG 94		

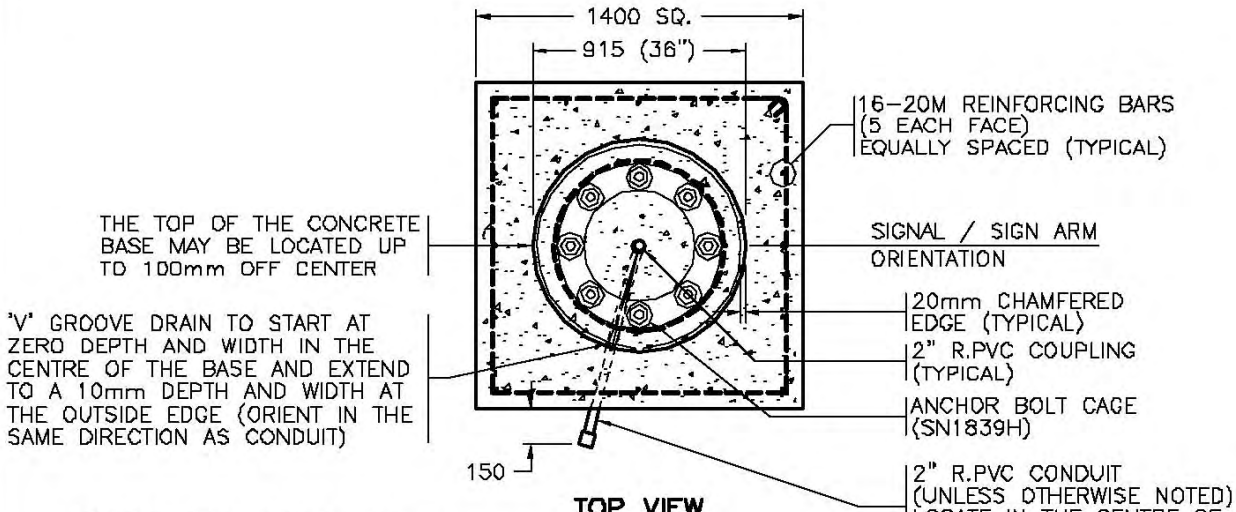

THE TOP OF THE CONCRETE BASE MAY BE LOCATED UP TO 100mm OFF CENTER

V GROOVE DRAIN TO START AT ZERO DEPTH AND WIDTH IN THE CENTRE OF THE BASE AND EXTEND TO A 10mm DEPTH AND WIDTH AT THE OUTSIDE EDGE (ORIENT IN THE SAME DIRECTION AS CONDUIT)

TOP VIEW

CONDUIT SHALL EXTEND 140mm ABOVE TOP OF CONCRETE

TROWEL FINISH TOP & CHAMFER EDGES

50 (UNLESS OTHERWISE NOTED)

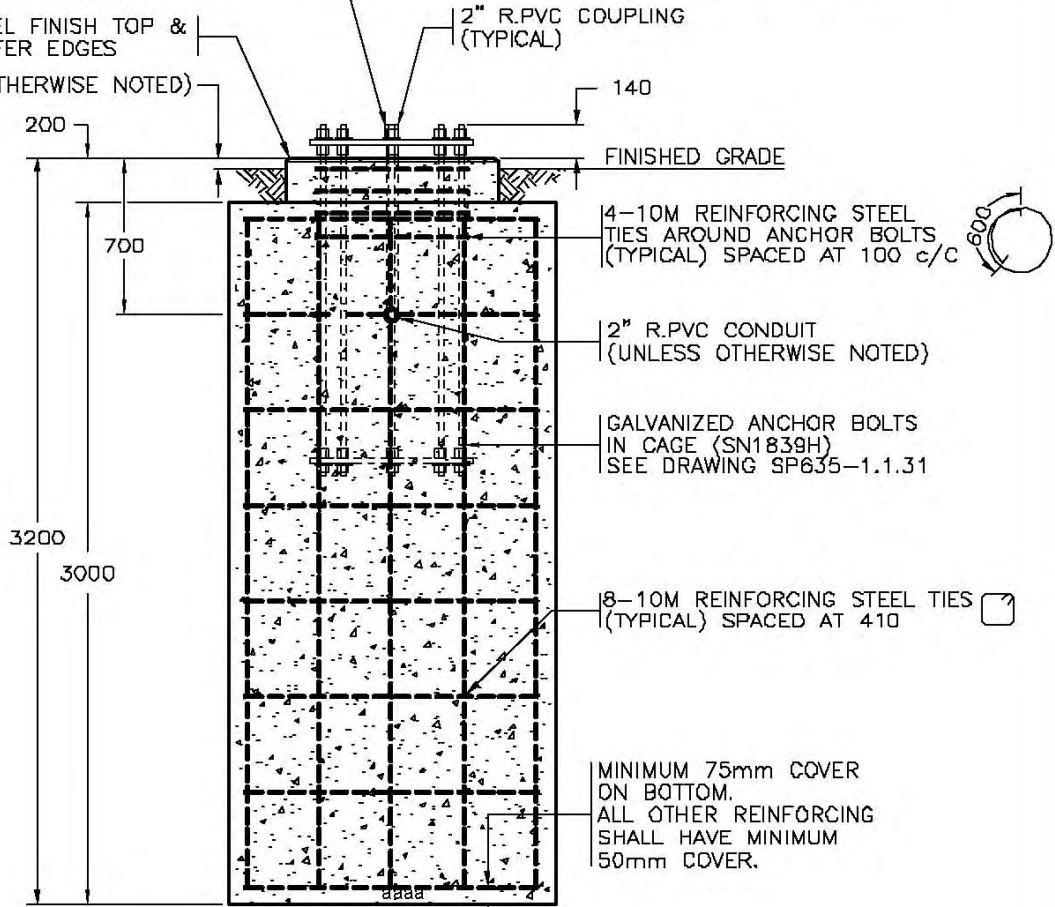

ELEVATION

SEE DRAWING SP635-1.1.29 FOR NOTES AND ADDITIONAL DETAILS

NOT TO SCALE



No.	Revision	Date
F		
E		
D		
C	ELEVATION OF BASE TO FINISHED GRADE REVISED	AUG 96
B	DRAWING REFERENCE CHANGED	AUG 95
A	GENERAL REVISIONS	AUG 94

**TYPE H2 CONCRETE BASE
(POURED IN PLACE)**

Date: **30/09/93** Approved: **E.L. (Signature on File)**
Chief Highway Engineer

SPECIFICATION DRAWING No. **SP635-1.1.30**

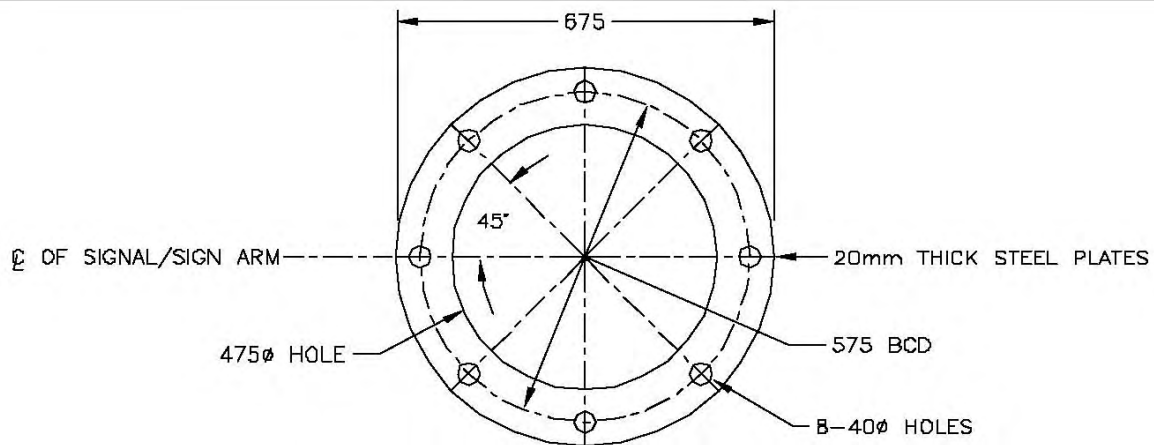

TOP AND BOTTOM PLATES

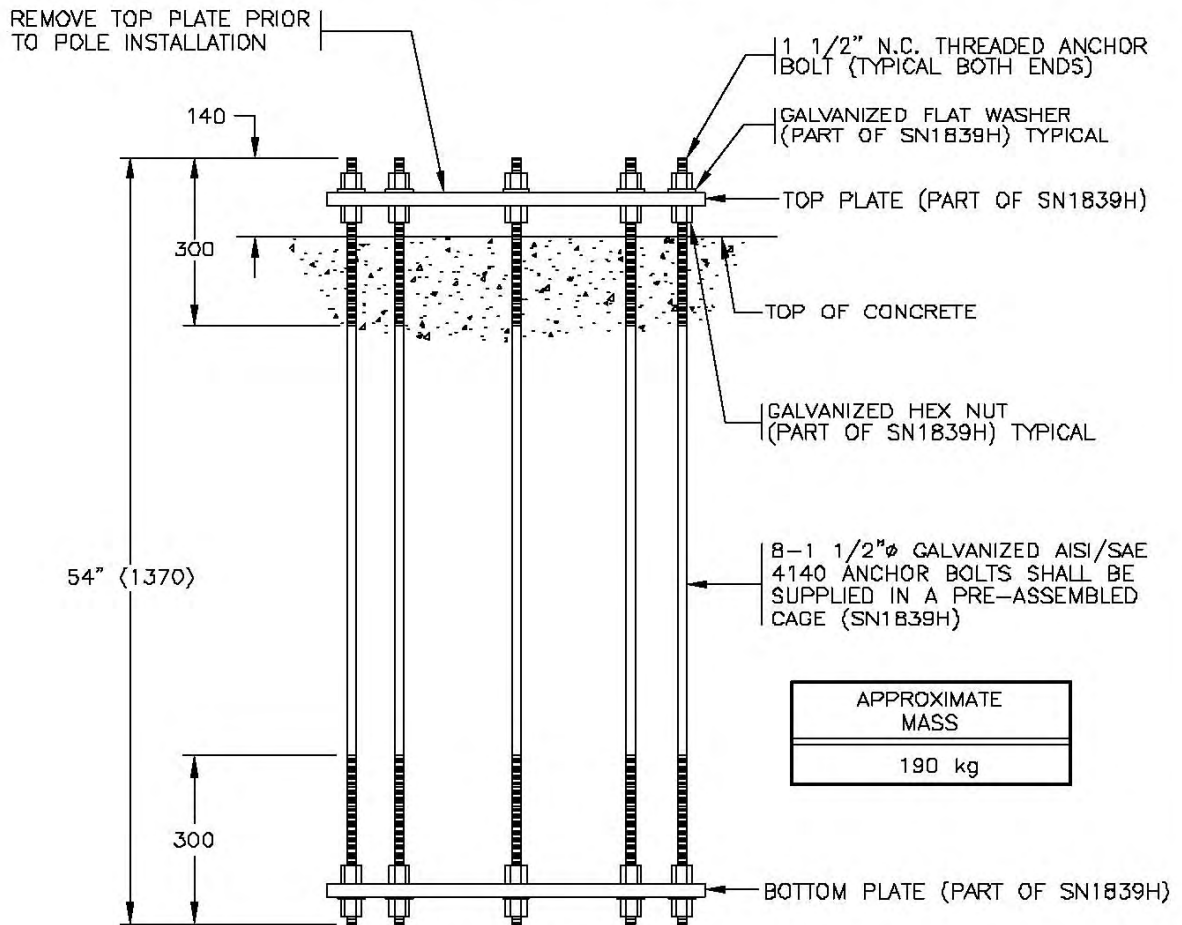

APPROXIMATE MASS
190 kg

ANCHOR BOLT CAGE
SN1839H

SEE DRAWINGS SP635-1.1.26 AND -1.1.29 FOR NOTES AND ADDITIONAL DETAILS

NOT TO SCALE



No.	Revision	Date
F		
E		
D		
C	TOP PLATE NOTE REVISED	OCT 03
B	HOLE SIZE IN PLATE REVISED	AUG 95
A	GENERAL REVISIONS	AUG 94

ANCHOR BOLT CAGE FOR TYPE H POLES		SPECIFICATION DRAWING No.
Date	Approved	SP635-1.1.31
30/09/93	E.L. (Signature on File) Chief Highway Engineer	

CONCRETE SHALL HAVE ATTAINED A COMPRESSIVE STRENGTH OF 30MPa PRIOR TO BREAKAWAY STRUCTURE INSTALLATION.

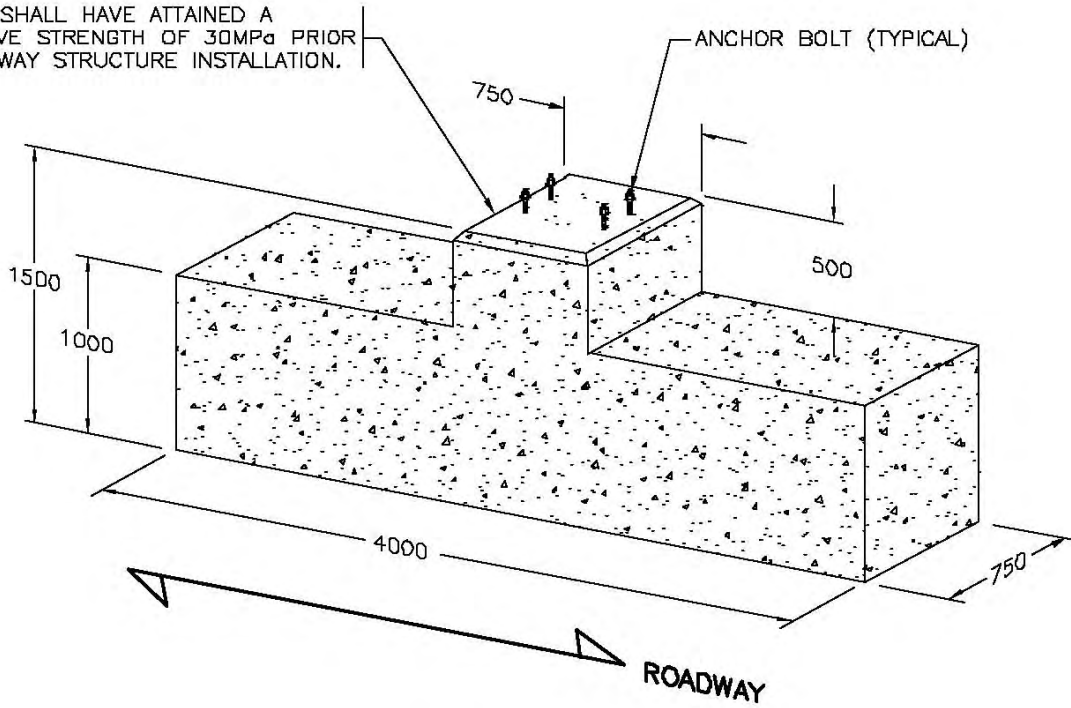

CONCRETE SPREAD FOOTING

BASE DESIGNED FOR SOILS WITH A MINIMUM BEARING PRESSURE OF 75KPa

APPROXIMATE MASS
8000 kg

VOLUME OF CONCRETE
3.28 m ³

NOTES

- SEE STANDARD SPECIFICATIONS & SPECIAL PROVISIONS FOR ADDITIONAL INFORMATION.
- MINIMUM 2 BASES REQUIRED PER BREAKAWAY SIGN INSTALLATION.
- 'SN' DENOTES MINISTRY STOCK NUMBER. aaaa
- SEE DRAWINGS SP635-1.1.33 AND 1.1.34 FOR ADDITIONAL DETAILS.
- ALL DIMENSIONS ARE IN MILLIMETRES UNLESS OTHERWISE NOTED.

NOT TO SCALE



No.	Revision	Date
F		
E		
D		
C		
B	DRAWING TITLE & NUMBER CHANGED	AUG 95
A	GENERAL REVISIONS	AUG 94

CONCRETE SPREAD FOOTING FOR BREAKAWAY SIGN STRUCTURE (POURED IN PLACE)

Date	Approved
30/09/93	E.L. (Signature on File)
	Chief Highway Engineer

SPECIFICATION DRAWING No.
SP635-1.1.32

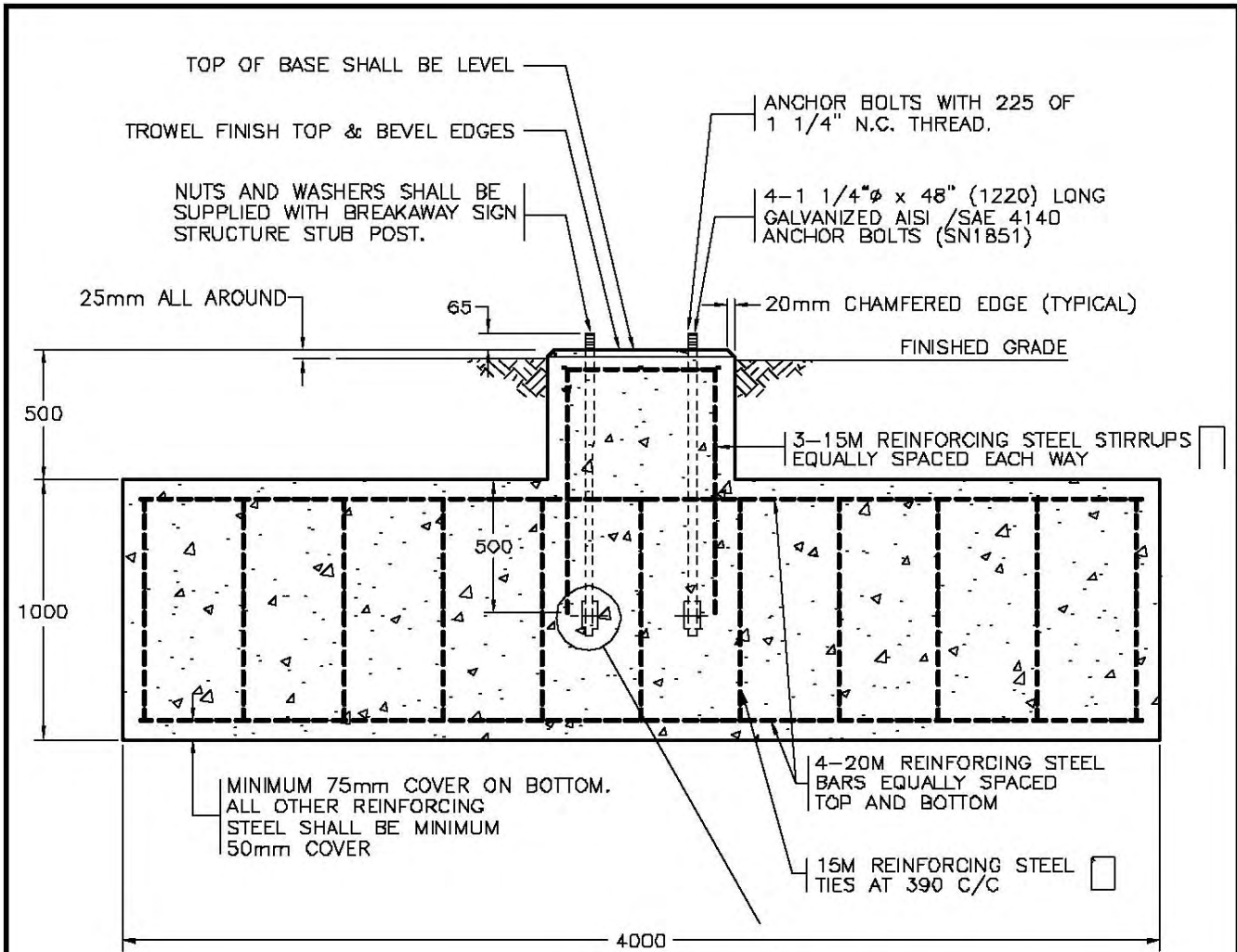

SIDE VIEW

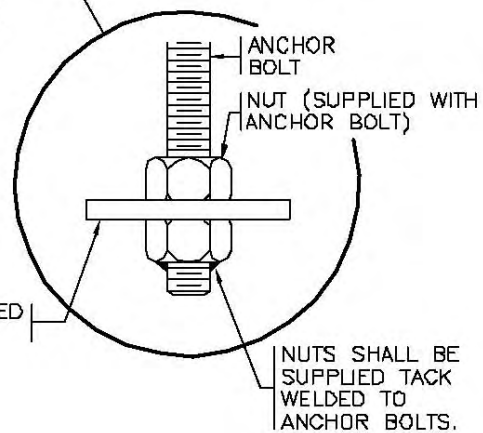

SEE DRAWING SP635-1.1.32 FOR NOTES AND ADDITIONAL DETAILS



NOT TO SCALE

No.	Revision	Date	CONCRETE SPREAD FOOTING FOR BREAKAWAY SIGN STRUCTURE (POURED IN PLACE)		SPECIFICATION DRAWING No. SP635-1.1.33
F			Date	Approved	
E			30/09/93	E.L. (Signature on File)	
D				Chief Highway Engineer	
C					
B	DRAWING TITLE & NUMBER CHANGED	AUG 95			
A	GENERAL REVISIONS	AUG 94			

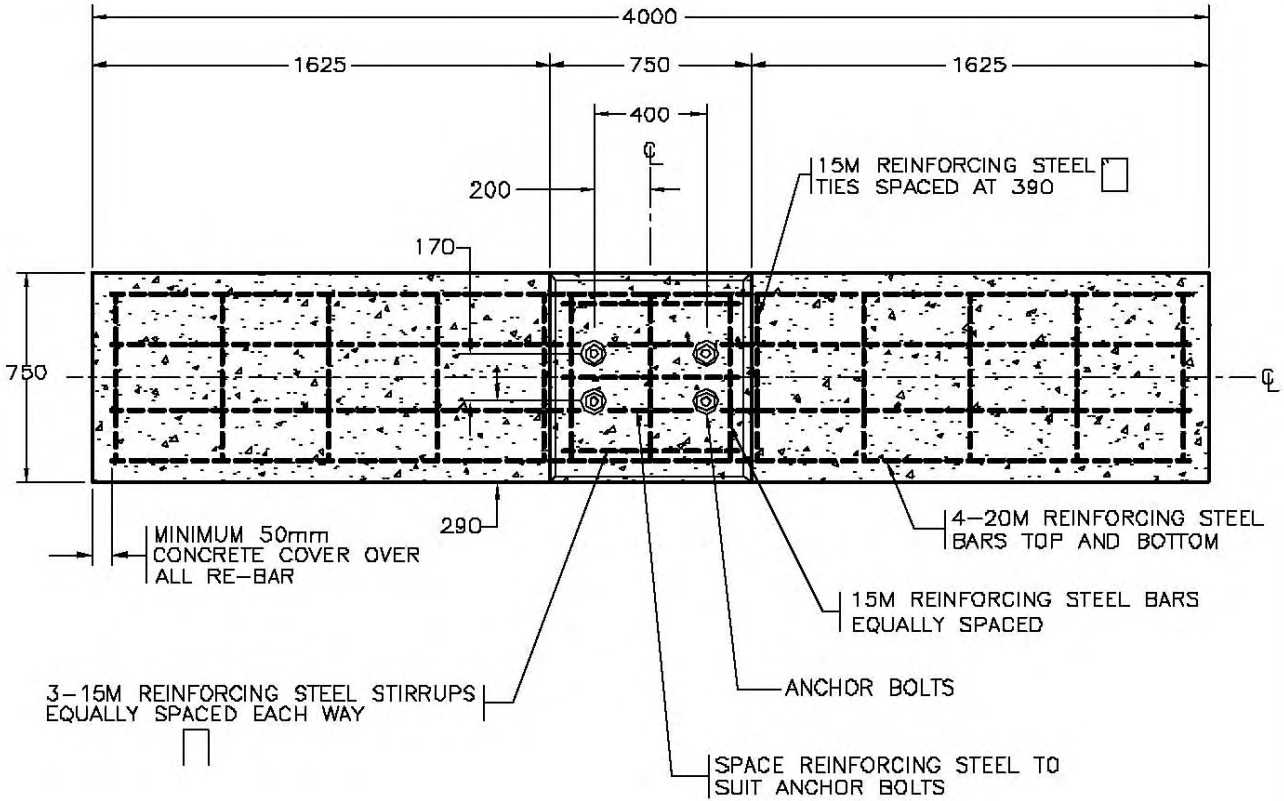

TOP VIEW

aaaa

SEE DRAWING SP635-1.1.32 FOR NOTES AND ADDITIONAL DETAILS



NOT TO SCALE

No.	Revision	Date	CONCRETE SPREAD FOOTING FOR BREAKAWAY SIGN STRUCTURE (POURED IN PLACE)		SPECIFICATION DRAWING No.
F			Date	Approved	SP635-1.1.34
E			30/09/93	E.L. (Signature on File)	
D				Chief Highway Engineer	
C					
B	DRAWING TITLE & NUMBER CHANGED	AUG 95			
A	GENERAL REVISIONS	AUG 94			

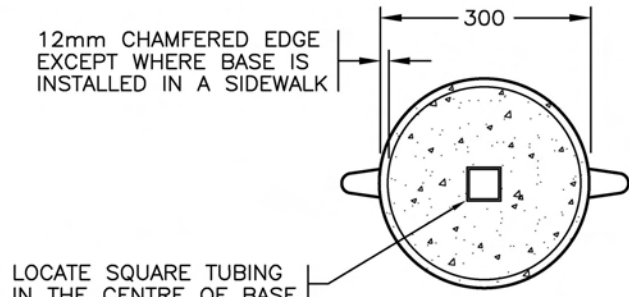

TOP VIEW

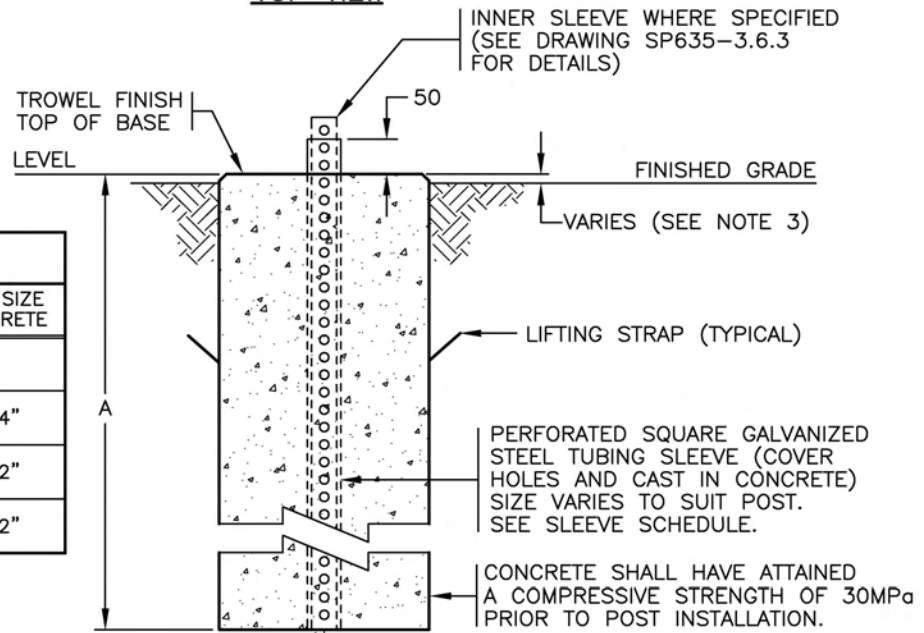

SIDE VIEW

SLEEVE SCHEDULE		
POST O.D.	INNER SLEEVE	SLEEVE SIZE IN CONCRETE
1 1/2"	YES	2"
1 3/4"	YES	2 1/4"
2"	YES	2 1/2"
2 1/4"	NO	2 1/2"

BASE TYPE	APPLICATION	APPROXIMATE MASS	VOLUME OF CONCRETE	A
1	SINGLE POST SIGNS IN PAVED ISLANDS OR CONCRETE SIDEWALKS	100 kg	0.04 m ³	600
2	SINGLE OR TWO POST SIGNS IN GRAVEL SHOULDER	147 kg	0.06 m ³	800

NOTES

- SEE STANDARD SPECIFICATIONS & SPECIAL PROVISIONS FOR ADDITIONAL INFORMATION.
- 'SN' DENOTES MINISTRY STOCK NUMBER.
- BASE SHALL BE INSTALLED 25mm ABOVE FINISHED GRADE EXCEPT WHERE INSTALLED IN SIDEWALK IT SHALL BE FLUSH WITH TOP OF SIDEWALK WITH NO CHAMFERED EDGE.
- ALL DIMENSIONS ARE IN MILLIMETRES UNLESS OTHERWISE NOTED.

SEE SPECIAL PROVISIONS FOR ALTERNATIVE BASES FOR SINGLE POST SIGNS



NOT TO SCALE

No.	Revision	Date
F	REVISED NOTE	JUNE 08
E	GENERAL REVISIONS	APR 05
D	NOTE IN BOX ADDED	NOV 98
C	DRAWING NUMBER CHANGED	AUG 95
B	GENERAL REVISIONS	AUG 94
A	PIPE SLEEVE CHANGED	FEB 94

ROUND CONCRETE BASES FOR PERFORATED SQUARE STEEL SIGN POSTS (PRECAST OR Poured IN PLACE)

Date: MAR 94
 Approved: E.L. (Signature on File)
 Chief Highway Engineer

SPECIFICATION
 DRAWING No.
SP635-1.1.35

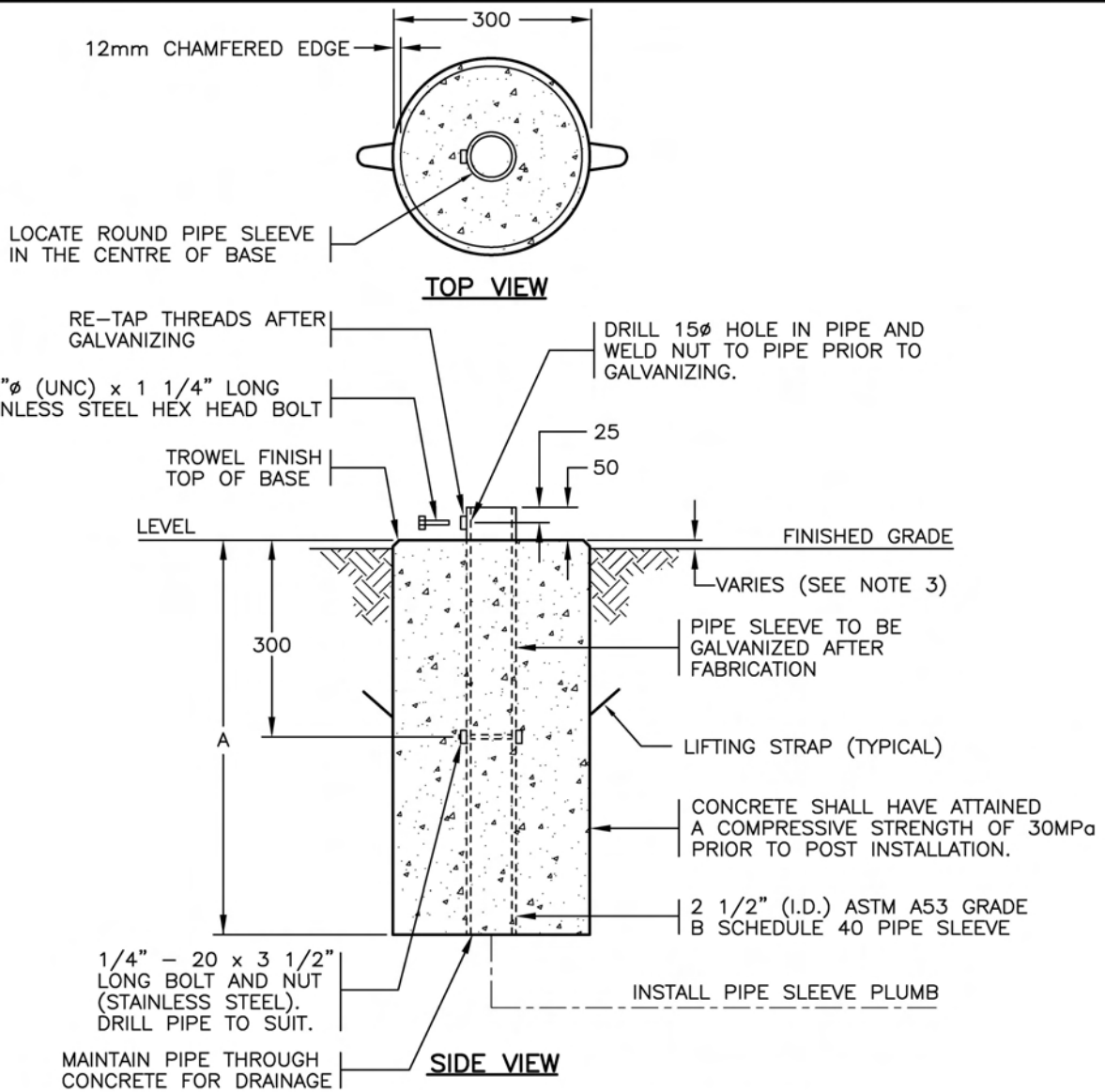

BASE TYPE	APPLICATION	APPROXIMATE MASS	VOLUME OF CONCRETE	A
1	SINGLE POST SIGNS IN PAVED ISLANDS OR CONCRETE SIDEWALKS	100 kg	0.04 m ³	600
2	SINGLE OR TWO POST SIGNS IN GRAVEL SHOULDER	147 kg	0.06 m ³	800

NOTES

- SEE STANDARD SPECIFICATIONS & SPECIAL PROVISIONS FOR ADDITIONAL INFORMATION.
- 'SN' DENOTES MINISTRY STOCK NUMBER.
- BASE SHALL BE INSTALLED 25mm ABOVE FINISHED GRADE EXCEPT WHERE INSTALLED IN SIDEWALK IT SHALL BE FLUSH WITH TOP OF SIDEWALK WITH NO CHAMFERED EDGE.
- ALL DIMENSIONS ARE IN MILLIMETRES UNLESS OTHERWISE NOTED.

SEE SPECIAL PROVISIONS FOR ALTERNATIVE BASES FOR SINGLE POST SIGNS



NOT TO SCALE

No.	Revision	Date	ROUND CONCRETE BASES FOR ROUND STEEL SIGN POSTS (PRECAST OR POURED IN PLACE)		SPECIFICATION DRAWING No. SP635-1.1.36
F			Date	Approved	
E	REVISED NOTE	JUNE 08	30/09/93	E.L. (Signature on File)	
D	GENERAL REVISIONS	APR 05		Chief Highway Engineer	
C	NOTE IN BOX ADDED	NOV 98			
B	DRAWING NUMBER CHANGED	AUG 95			
A	GENERAL REVISIONS	AUG 94			

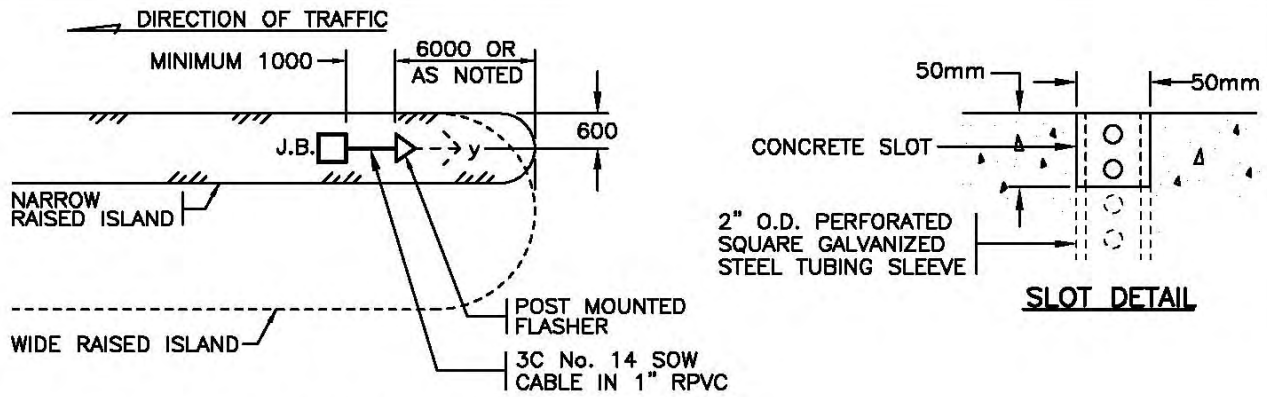

SITE PLAN OF FLASHER IN ISLAND

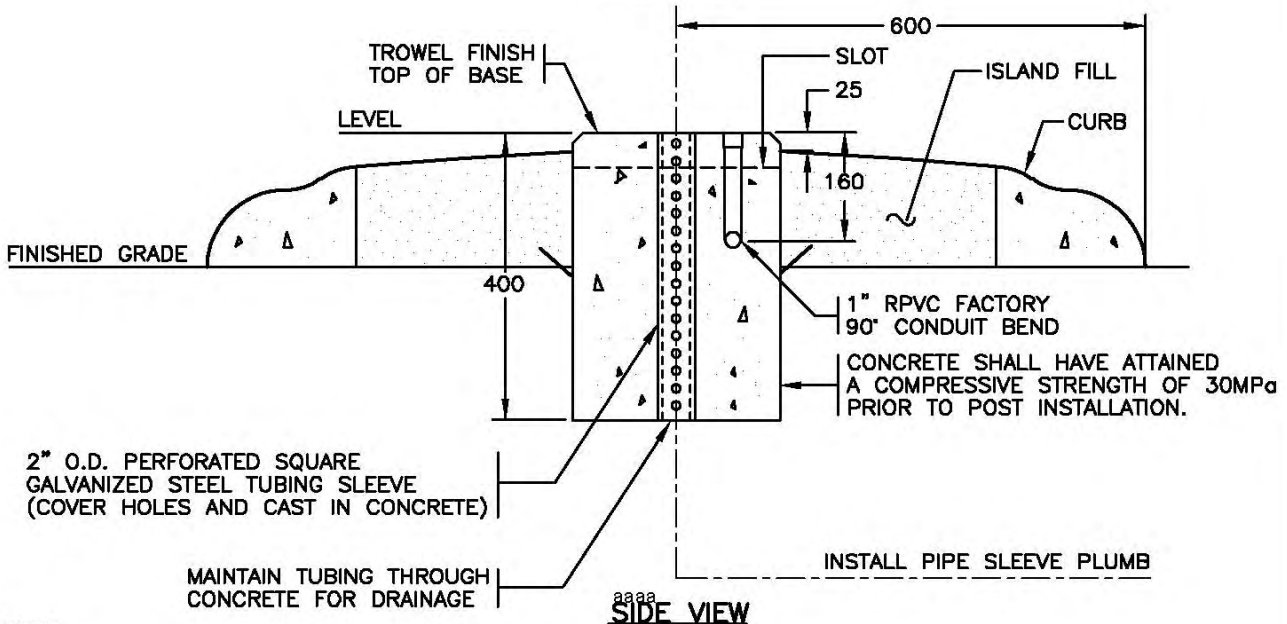
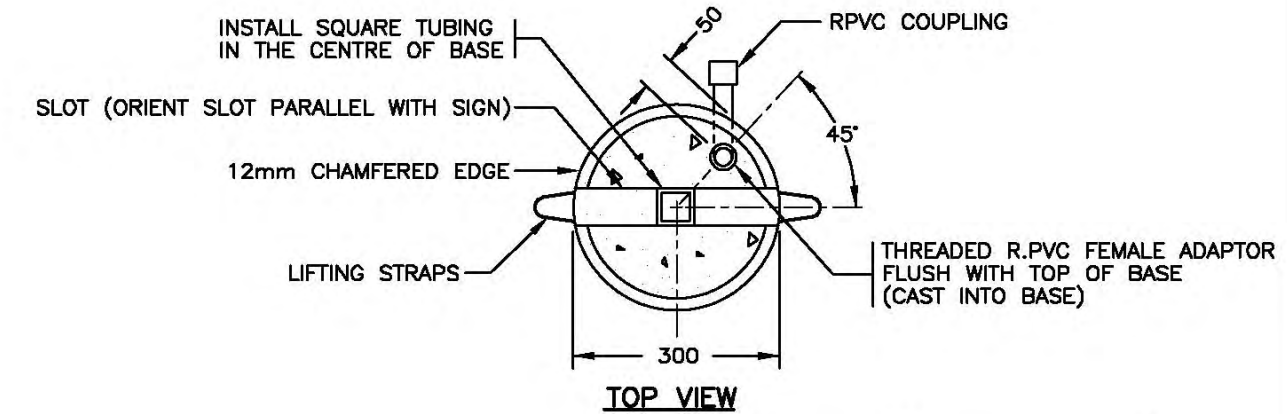

NOTES

1. SEE STANDARD SPECIFICATIONS & SPECIAL PROVISIONS FOR ADDITIONAL INFORMATION.
2. 'SN' DENOTES MINISTRY STOCK NUMBER.

NOT TO SCALE



No.	Revision	Date	ROUND POST MOUNTED FLASHER CONCRETE BASE (PRECAST OR POURED IN PLACE)		SPECIFICATION DRAWING No. SP635-1.1.37
F	GENERAL REVISIONS	APR 05	Date	Approved	
E	LOCATION IN ISLAND REVISED	SEPT 00	MAR 94	E.L. (Signature on File)	
D	DIM'N FROM SIDE OF ISLAND ADDED	NOV 99	Chief Highway Engineer		
C	NOTE 3 DELETED	AUG 96			
B	DRAWING NUMBER CHANGED	AUG 95			
A	GENERAL REVISIONS	AUG 94			

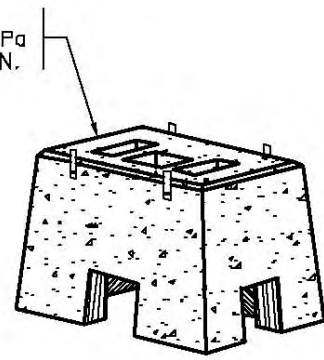
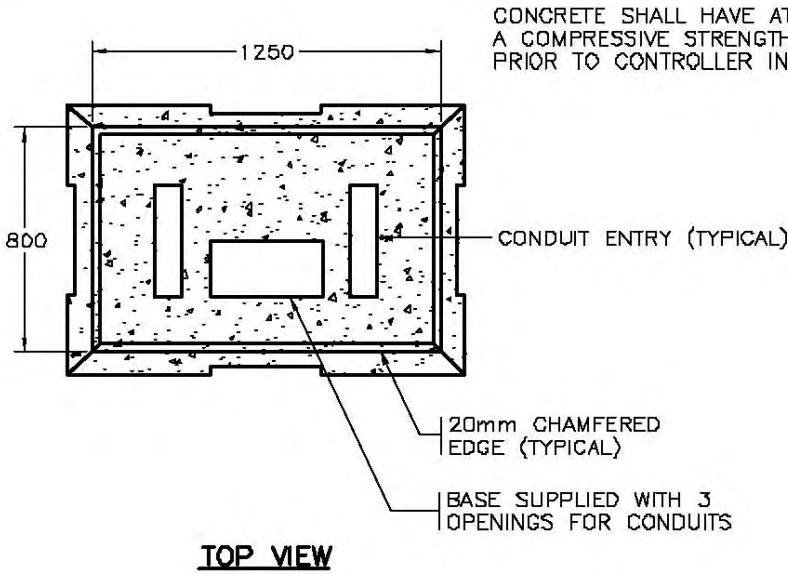

APPROXIMATE MASS
1500 kg

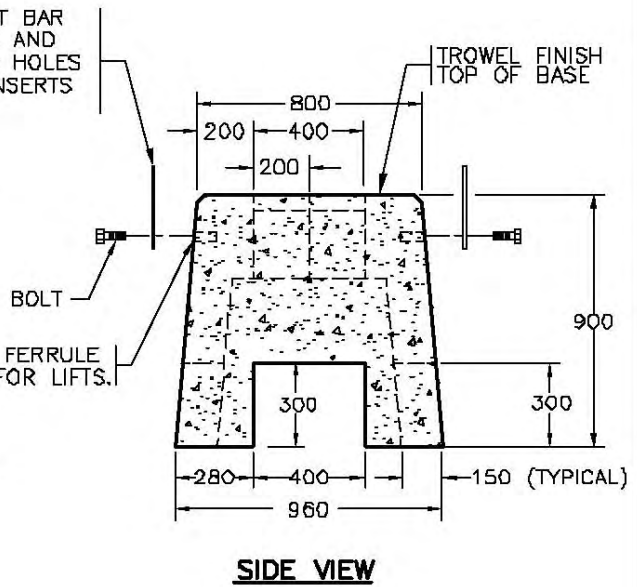
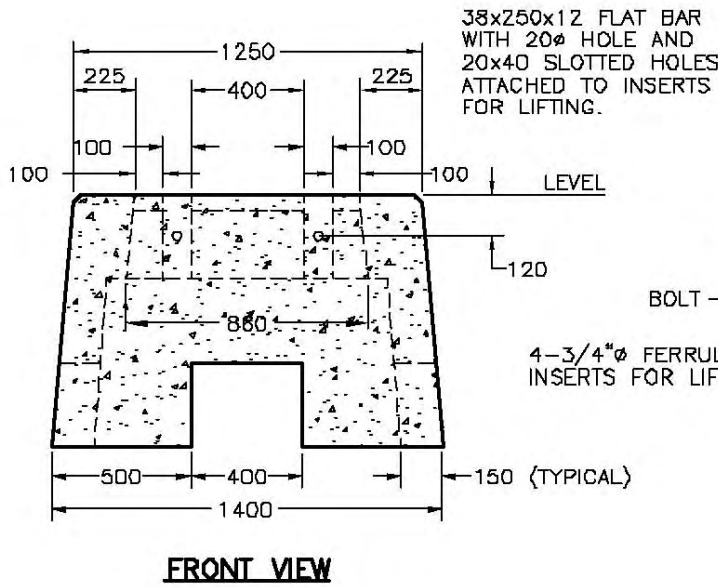

NOTES

1. SEE STANDARD SPECIFICATIONS & SPECIAL PROVISIONS FOR ADDITIONAL INFORMATION.
2. SEE DRAWING SP635-1.1.39 FOR REBAR DETAILS,^{aaaa} AND DRAWINGS SP635-1.1.40 AND 1.1.41 FOR INSTALLATION DETAILS.
3. ALL DIMENSIONS ARE IN MILLIMETRES UNLESS OTHERWISE NOTED.

NOT TO SCALE



No.	Revision	Date	CONCRETE CONTROLLER BASE DETAILS (PRECAST)		SPECIFICATION DRAWING No. SP635-1.1.38
F			Date	Approved	
E			30/09/93	E.L. (Signature on File) Chief Highway Engineer	
D					
C	DRAWING REFERENCE NUMBERS REVISED	AUG 96			
B	DRAWING NUMBER CHANGED	AUG 95			
A	GENERAL REVISIONS	AUG 94			

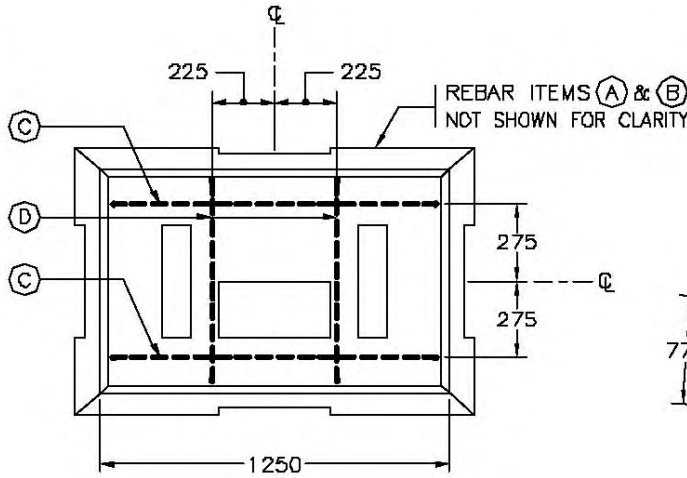

TOP VIEW

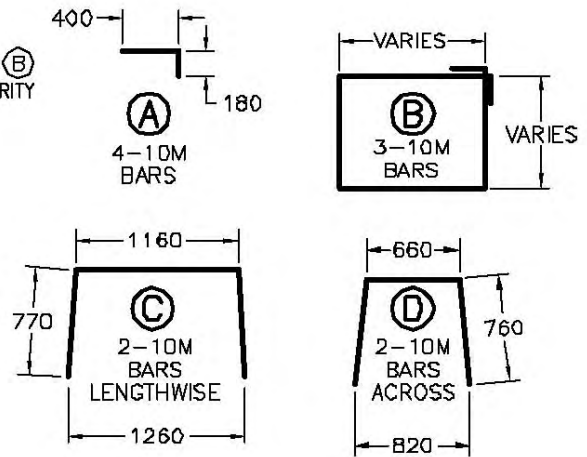

REINFORCEMENT DETAILS

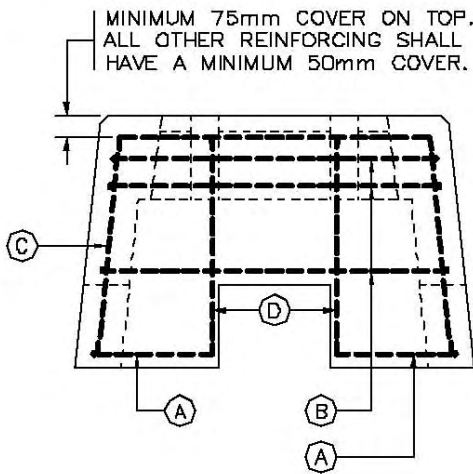

FRONT VIEW

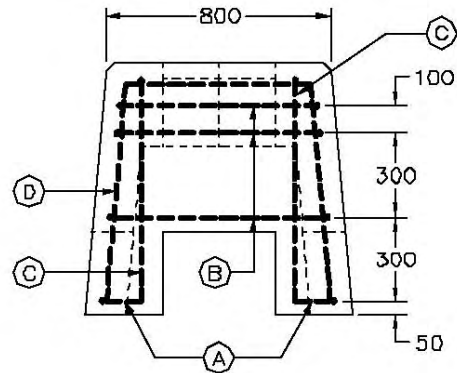

SIDE VIEW

aaaa

SEE DRAWING SP635-1.1.3B FOR NOTES AND DETAILS

NOT TO SCALE



No.	Revision	Date
F		
E		
D		
C		
B	DRAWING NUMBER CHANGED	AUG 95
A	GENERAL REVISIONS	AUG 94

CONCRETE CONTROLLER BASE REBAR DETAILS (PRECAST)

Date Approved
30/09/93 E.L. (Signature on File)
 Chief Highway Engineer

SPECIFICATION DRAWING No.
SP635-1.1.39

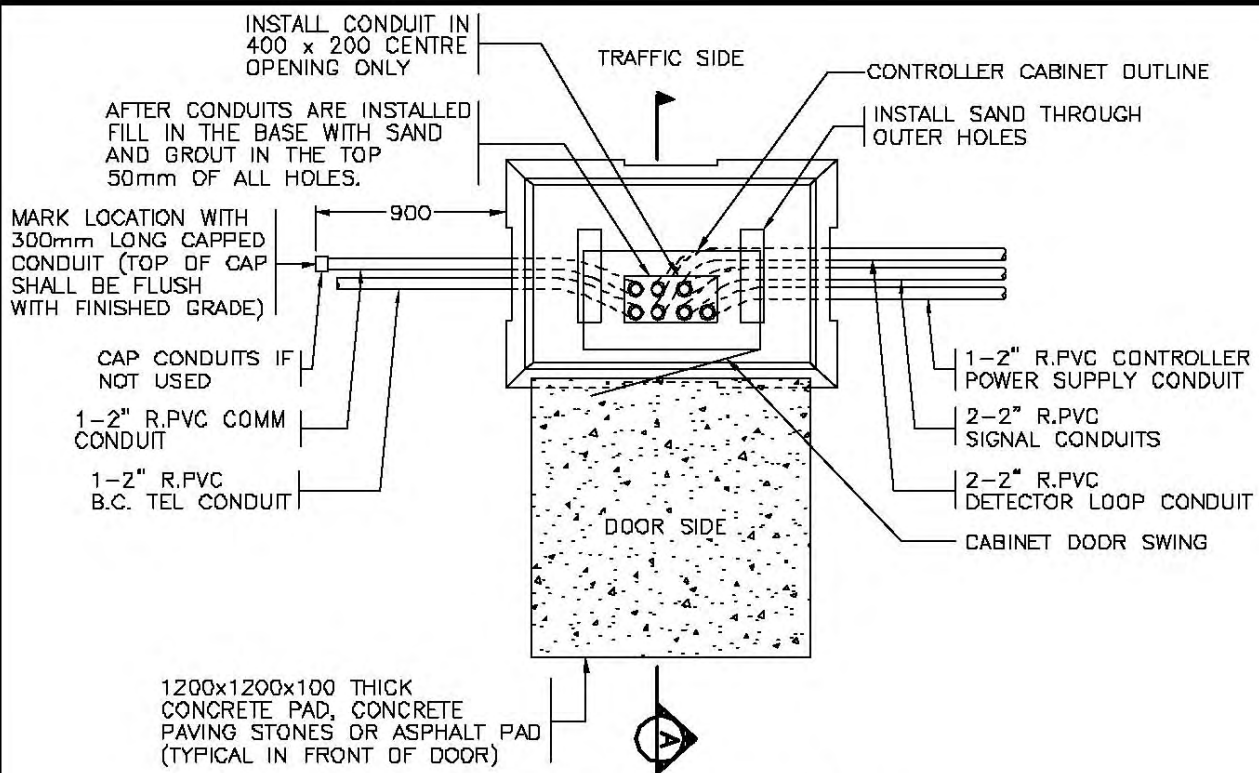

CONDUIT FIELD INSTALLATION

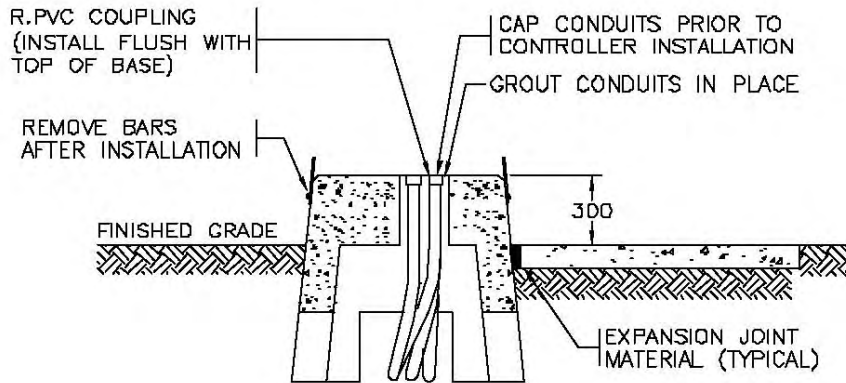

SECTION A

NOTES

1. SEE STANDARD SPECIFICATIONS & SPECIAL PROVISIONS FOR ADDITIONAL INFORMATION.
2. INSTALL CONDUITS AND GROUT PRIOR TO CONTROLLER INSTALLATION.
3. CONDUITS AND ROUTING MAY VARY. EXACT CONDUIT ROUTING SHALL BE AS INDICATED ON THE TRAFFIC SIGNAL DESIGN DRAWINGS.
4. ALL DIMENSIONS ARE IN MILLIMETRES UNLESS OTHERWISE NOTED.

NOT TO SCALE



No.	Revision	Date
F		
E		
D		
C		
B	MARKER ADDED TO LOCATE CONDUIT STUBS	AUG 95
A	GENERAL REVISIONS	AUG 94

**CONTROLLER BASE INSTALLATION DETAILS
(FOR TYPE M CABINET)**

Date Approved
30/09/93 E.L. (Signature on File)
 Chief Highway Engineer

SPECIFICATION
 DRAWING No.
SP635-1.1.40

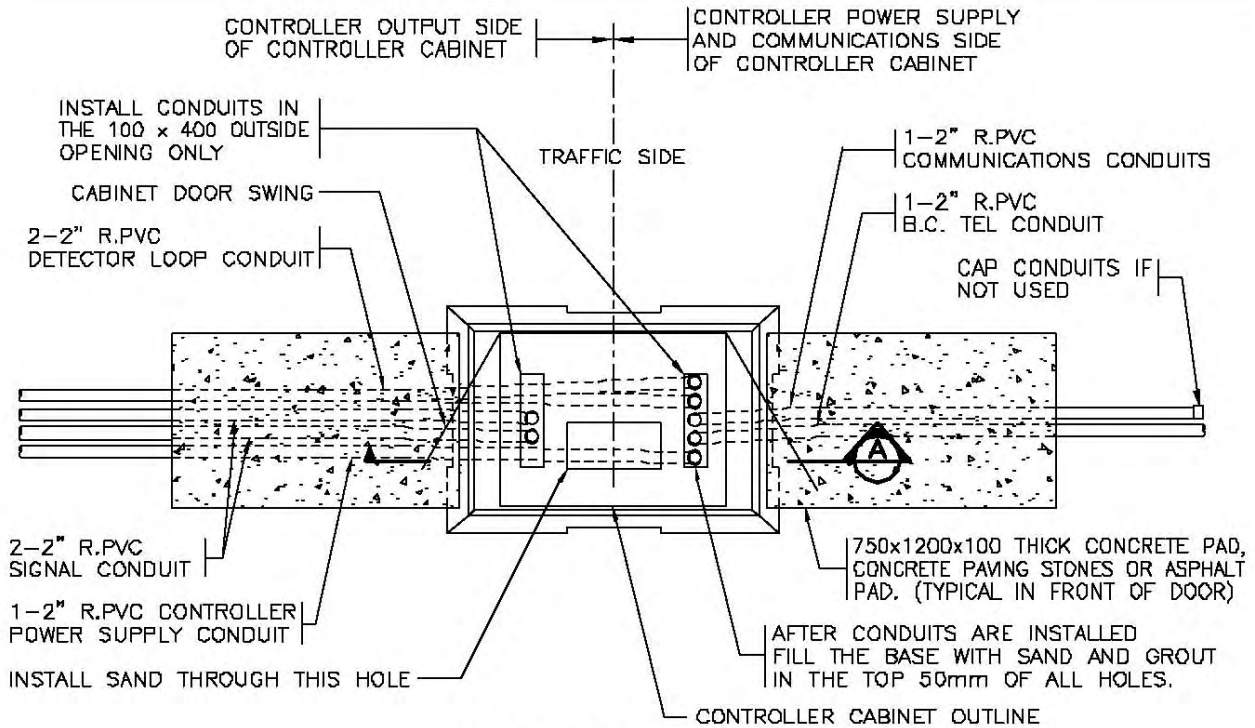

CONDUIT FIELD INSTALLATION

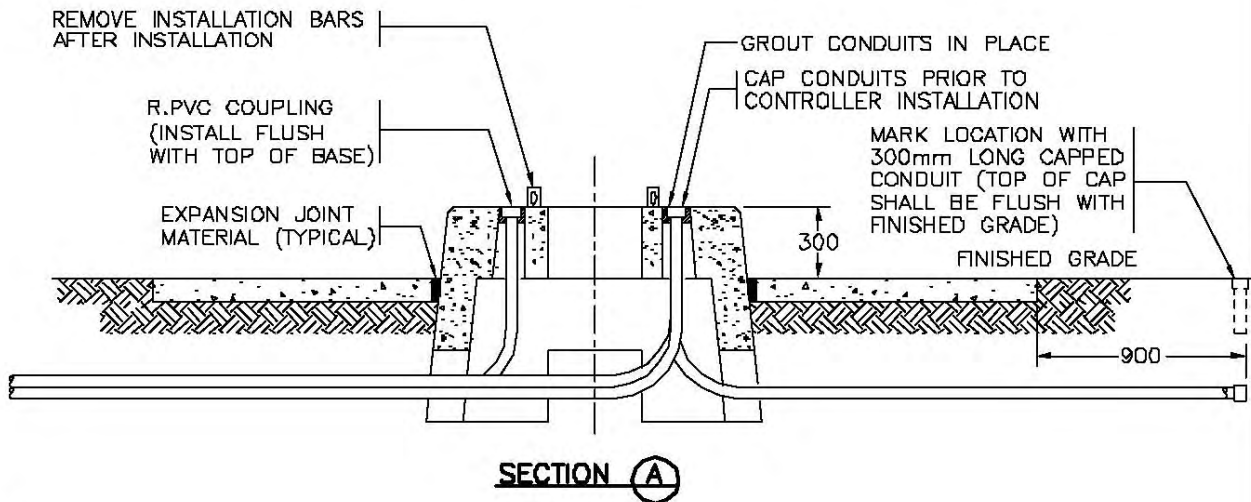

NOTES

1. SEE STANDARD SPECIFICATIONS & SPECIAL PROVISIONS FOR ADDITIONAL INFORMATION.
2. INSTALL CONDUITS AND GROUT PRIOR TO CONTROLLER INSTALLATION.
3. CONDUITS AND ROUTING MAY VARY. EXACT CONDUIT ROUTING SHALL BE AS INDICATED ON THE PLANS.
4. ALL DIMENSIONS ARE IN MILLIMETRES UNLESS OTHERWISE NOTED.

NOT TO SCALE



No.	Revision	Date
F		
E		
D		
C		
B	MARKER ADDED TO LOCATE CONDUIT STUBS	AUG 95
A	GENERAL REVISIONS	AUG 94

**CONTROLLER BASE INSTALLATION DETAILS
(FOR TYPE S CABINET)**

Date Approved
30/09/93 E.L. (Signature on File)
 Chief Highway Engineer

SPECIFICATION
 DRAWING No.
SP635-1.1.41

ANCHOR BOLT REPAIR PROCEDURES

1.0 GENERAL

ANCHOR BOLT DAMAGE IS CLASSED AS THE BENDING OR STRETCHING OF THE BOLTS TO THE POINT THAT A POLE CAN NOT BE REMOVED OR INSTALLED.

2.0 REPAIR PROCEDURE

REPAIR OF ANCHOR BOLTS SHALL BE AS DETAILED ON DRAWING SP635-1.1.43.

WHERE AN ANCHOR BOLT REQUIRES REPAIR, THE BOLT SHALL BE CUT OFF AND A COUPLER INSTALLED. ANCHOR BOLT COUPLERS SHALL BE USED AS FOLLOWS:

- A) 4 ANCHOR BOLT BASE - MAXIMUM 1 COUPLER PER BASE
- B) 6 TO 8 ANCHOR BOLT BASE - MAXIMUM 2 COUPLERS PER BASE
- C) 10 TO 12 ANCHOR BOLT BASE - MAXIMUM 3 COUPLERS PER BASE

WHERE THE NUMBER OF COUPLERS REQUIRED PER BASE EXCEEDS THE NUMBER ALLOWED, THE BASE MUST BE REPLACED.

ANY DEVIATIONS FROM THESE PROCEDURES MUST BE APPROVED BY THE "MINISTRY ELECTRICAL REPRESENTATIVE" PRIOR TO CONSTRUCTION.

aaaa



No.	Revision	Date	ANCHOR BOLT REPAIR PROCEDURES	
F			Date	Approved
E			18/11/94	E.L. (Signature on File)
D			Chief Highway Engineer	
C			SPECIFICATION DRAWING No.	SP635-1.1.42
B	REFERENCE CHANGED TO "MINISTRY ELECTRICAL REPRESENTATIVE"	OCT 03		
A	DRAWING NUMBER CHANGED	AUG 95		

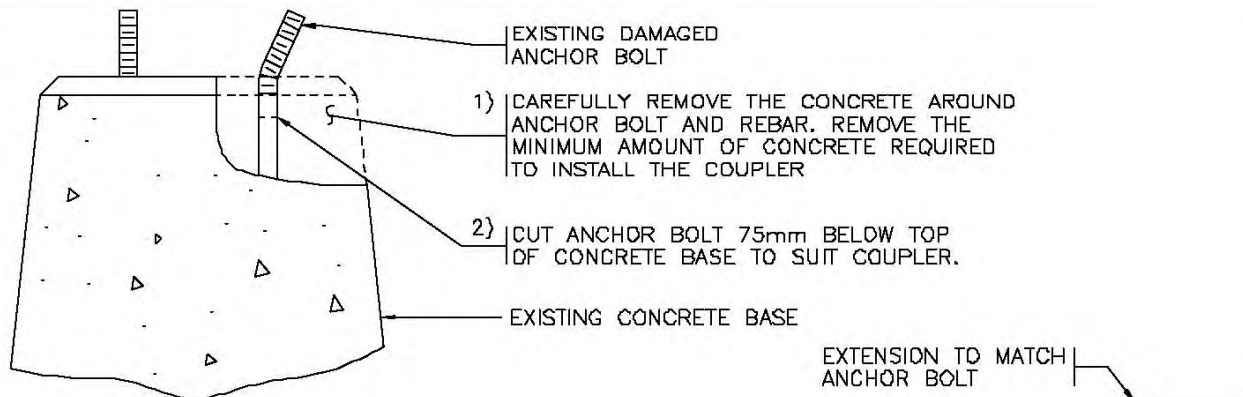

STEP 1

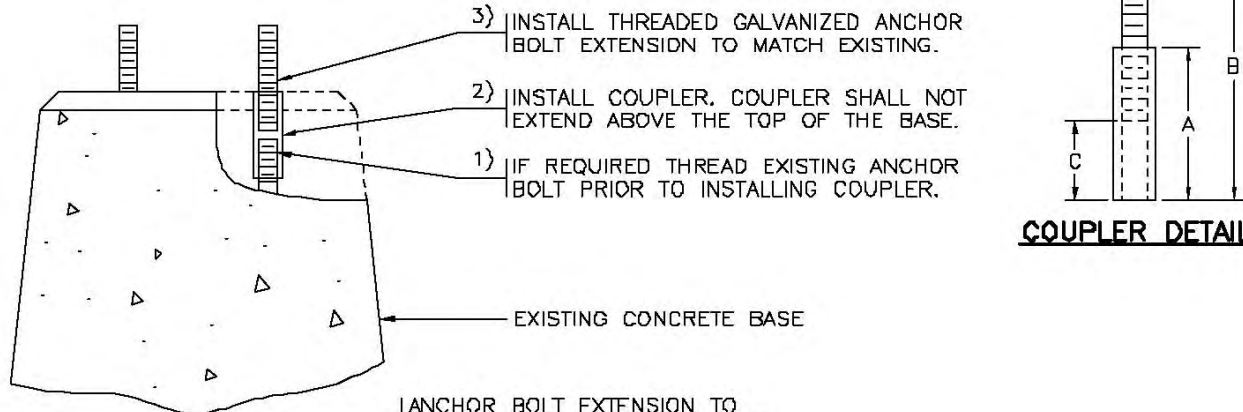

STEP 2

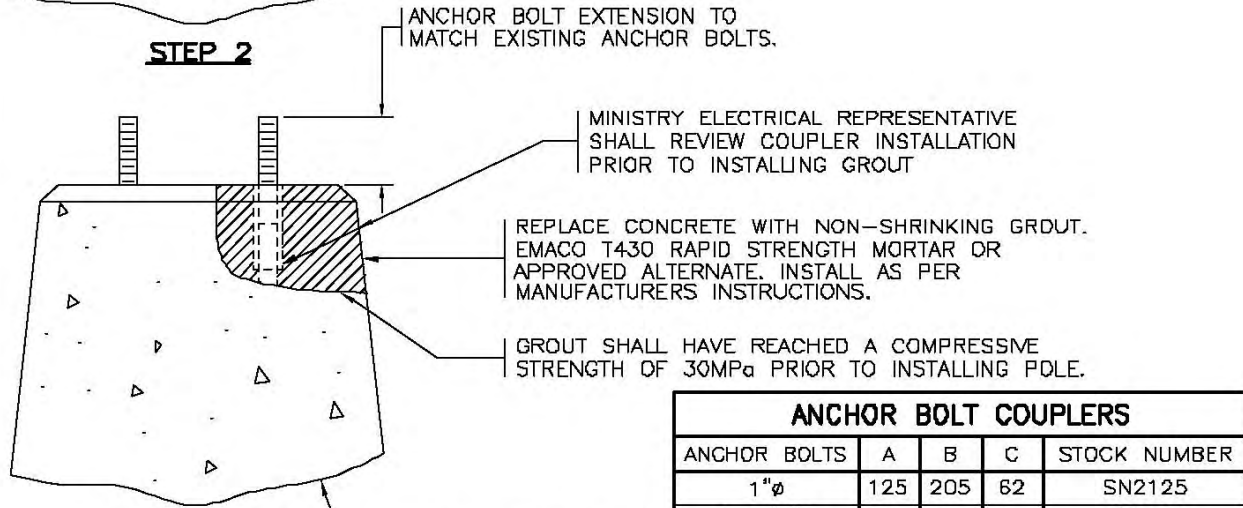

STEP 3

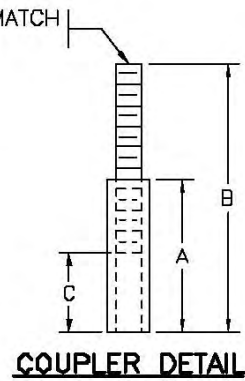

ANCHOR BOLT COUPLERS				
ANCHOR BOLTS	A	B	C	STOCK NUMBER
1"φ	125	205	62	SN2125
1 1/4"φ	125	205	62	SN2126
1 1/2"φ	125	265	62	SN2127
1"φ (DYWIDAG)	150	310	75	SN2128

NOTES

- SEE STANDARD SPECIFICATIONS & SPECIAL PROVISIONS FOR ADDITIONAL INFORMATION.
- SEE DRAWING SP635-1.1.42 FOR ADDITIONAL INFORMATION.

aaaa

ALL COUPLERS SHALL HAVE A MINIMUM OF 125% OF THE SPECIFIED ANCHOR BOLT YIELD STRENGTH



NOT TO SCALE

No.	Revision	Date
F		
E		
D		
C		
B	MINISTRY ELECTRICAL REPRESENTATIVE ADDED	OCT 03
A	DRAWING NUMBER CHANGED	AUG 95

ANCHOR BOLT REPAIR PROCEDURES

Date: **18/11/94** Approved: **E.L. (Signature on File)**
Chief Highway Engineer

SPECIFICATION DRAWING No. **SP635-1.1.43**

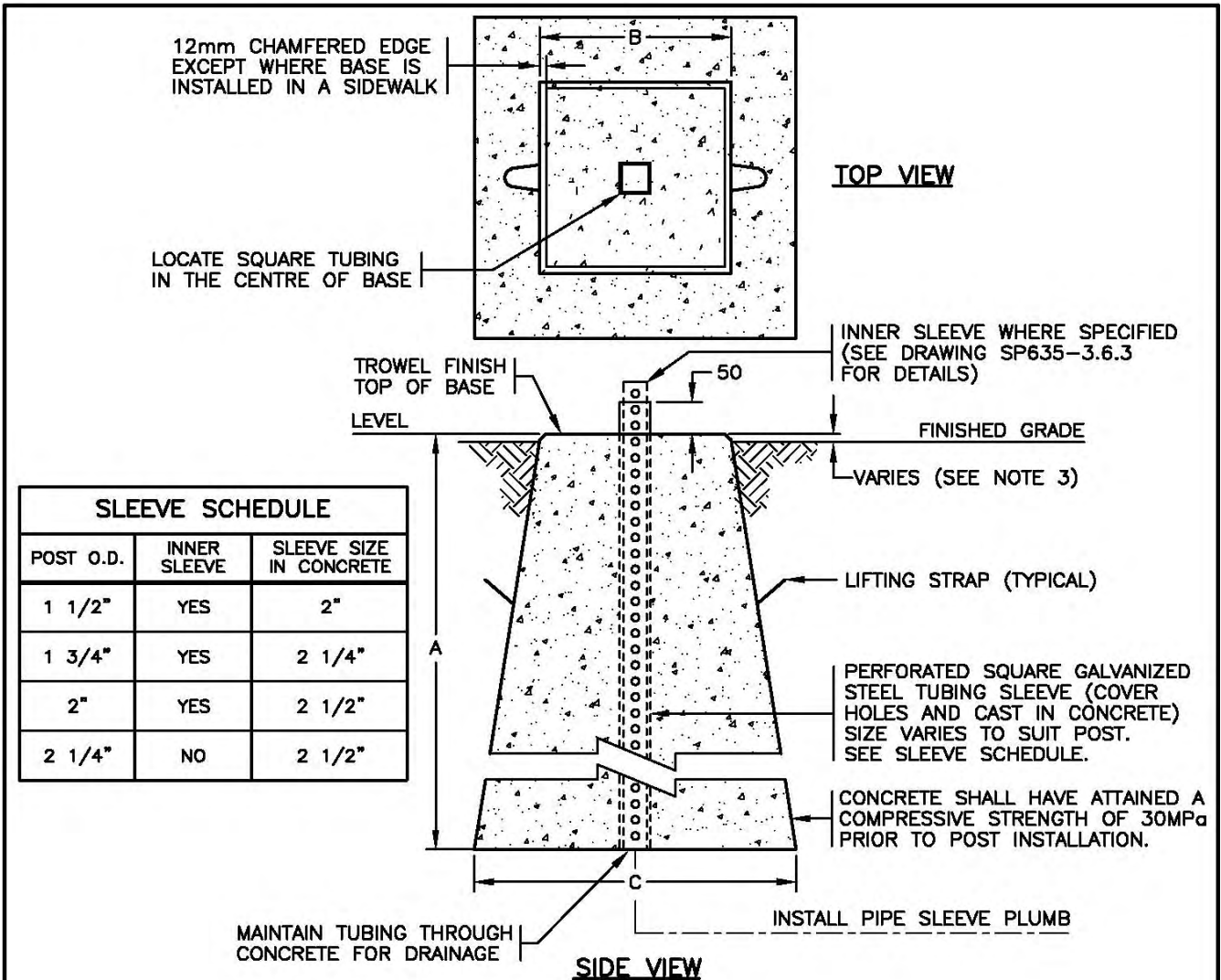

BASE TYPE	APPLICATION	APPROXIMATE MASS	VOLUME OF CONCRETE	A	B	C
a	SINGLE POST SIGNS IN PAVED ISLANDS OR CONCRETE SIDEWALKS	34 kg	0.015 m ³	400	160	230
b	SINGLE OR TWO POST SIGNS IN GRAVEL SHOULDER UP TO 1.0 x 1.2m	166 kg	0.068 m ³	470	300	460
c	TWO POST SIGNS IN GRAVEL SHOULDER UP TO 1.0 x 1.2m ≤ 1.2 x 2.4m	390 kg	0.16 m ³	750	330	600

NOTES

- SEE STANDARD SPECIFICATIONS & SPECIAL PROVISIONS FOR ADDITIONAL INFORMATION.
- 'SN' DENOTES MINISTRY STOCK NUMBER.
- BASE SHALL BE INSTALLED 25mm ABOVE FINISHED GRADE EXCEPT WHERE INSTALLED IN SIDEWALK IT SHALL BE FLUSH WITH TOP OF SIDEWALK WITH NO CHAMFERED EDGE.
- ALL DIMENSIONS ARE IN MILLIMETRES UNLESS OTHERWISE NOTED.

NOT TO SCALE



No.	Revision	Date	TRAPEZOIDAL CONCRETE BASES FOR PERFORATED SQUARE STEEL SIGN POSTS (PRECAST OR Poured IN PLACE)		
F					
E			Date	Approved	SPECIFICATION DRAWING No. SP635-1.1.44
D			APR 05 D.N. (Signature on File)		
C			Chief Engineer		
B					
A					

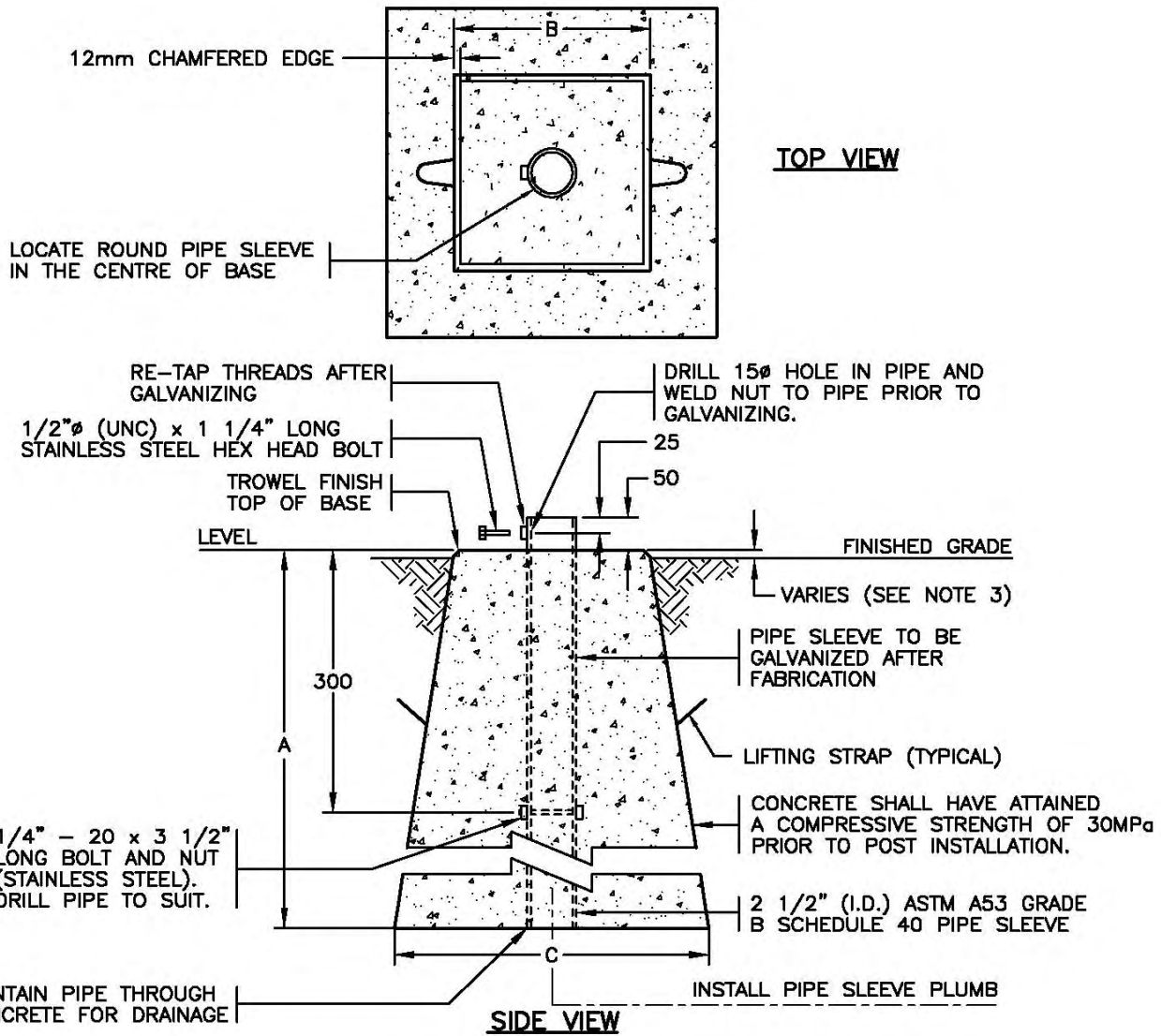

BASE TYPE	APPLICATION	APPROXIMATE MASS	VOLUME OF CONCRETE	A	B	C
a	SINGLE POST SIGNS IN PAVED ISLANDS OR CONCRETE SIDEWALKS	34 kg	0.015 m ³	400	160	230
b	SINGLE OR TWO POST SIGNS IN GRAVEL SHOULDER UP TO 1.0 x 1.2m	166 kg	0.068 m ³	470	300	460
c	TWO POST SIGNS IN GRAVEL SHOULDER UP TO 1.0 x 1.2m ≤ 1.2 x 2.4m	390 kg	0.16 m ³	750	330	600

NOTES

- SEE STANDARD SPECIFICATIONS & SPECIAL PROVISIONS FOR ADDITIONAL INFORMATION.
- 'SN' DENOTES MINISTRY STOCK NUMBER. aaaa
- BASE SHALL BE INSTALLED 25mm ABOVE FINISHED GRADE EXCEPT WHERE INSTALLED IN SIDEWALK IT SHALL BE FLUSH WITH TOP OF SIDEWALK WITH NO CHAMFERED EDGE.
- ALL DIMENSIONS ARE IN MILLIMETRES UNLESS OTHERWISE NOTED.

NOT TO SCALE



No.	Revision	Date	TRAPEZOIDAL CONCRETE BASE FOR ROUND STEEL SIGN POST (PRECAST OR POURED IN PLACE)		
F					
E			Date	Approved	SPECIFICATION DRAWING No. SP635-1.1.45
D			APR 05	D.N. (Signature on File) Chief Engineer	
C					
B					
A					

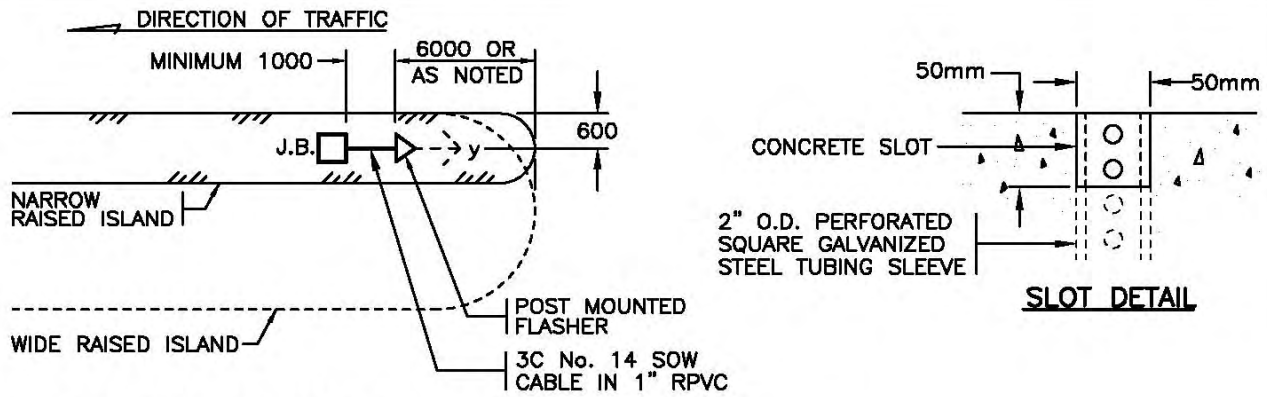

SITE PLAN OF FLASHER IN ISLAND

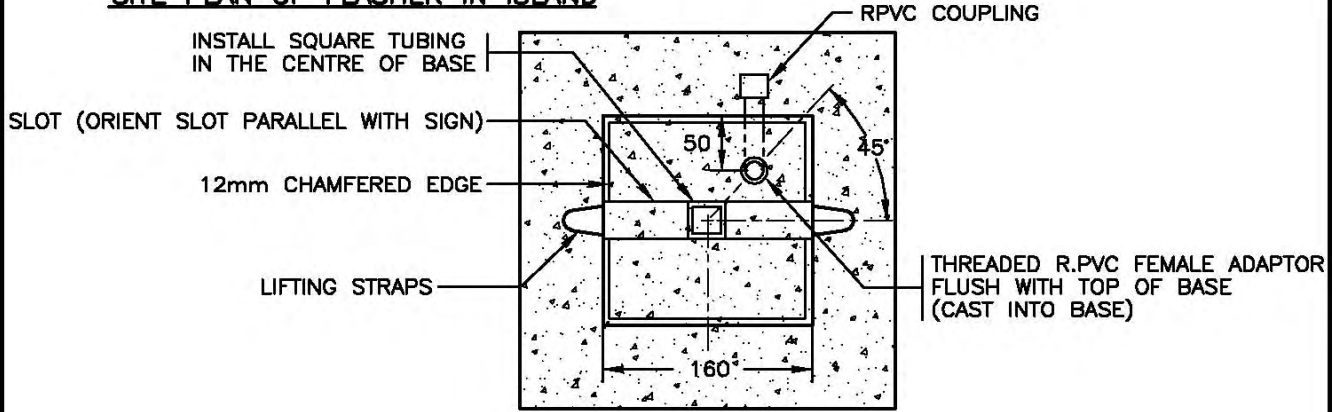

TOP VIEW

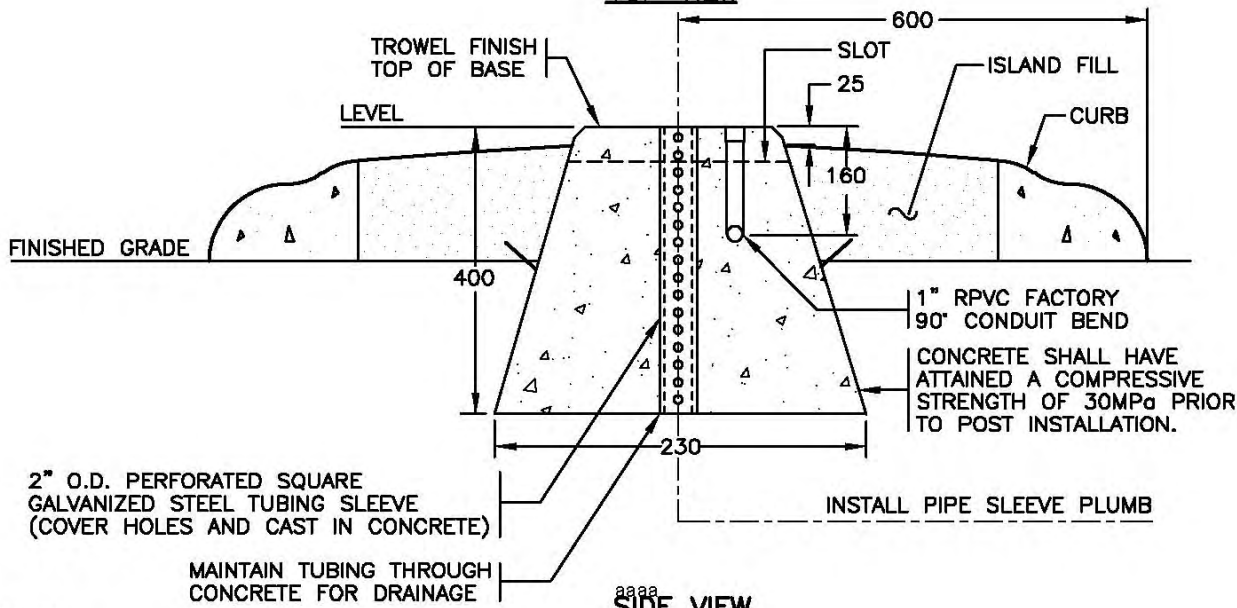

SIDE VIEW

NOTES

1. SEE STANDARD SPECIFICATIONS & SPECIAL PROVISIONS FOR ADDITIONAL INFORMATION.
2. 'SN' DENOTES MINISTRY STOCK NUMBER.

NOT TO SCALE



No.	Revision	Date	TRAPEZOIDAL POST MOUNTED FLASHER CONCRETE BASE (PRECAST OR Poured IN PLACE)		
F					
E					
D			Date	Approved	
C			<p>APR 05 D.N. (Signature on File) Chief Highway Engineer</p>		
B					SPECIFICATION DRAWING No.
A					SP635-1.1.46

NUMBER OF CONDUITS ENTERING JUNCTION BOX NOT TO EXCEED 10 (UNLESS OTHERWISE NOTED)

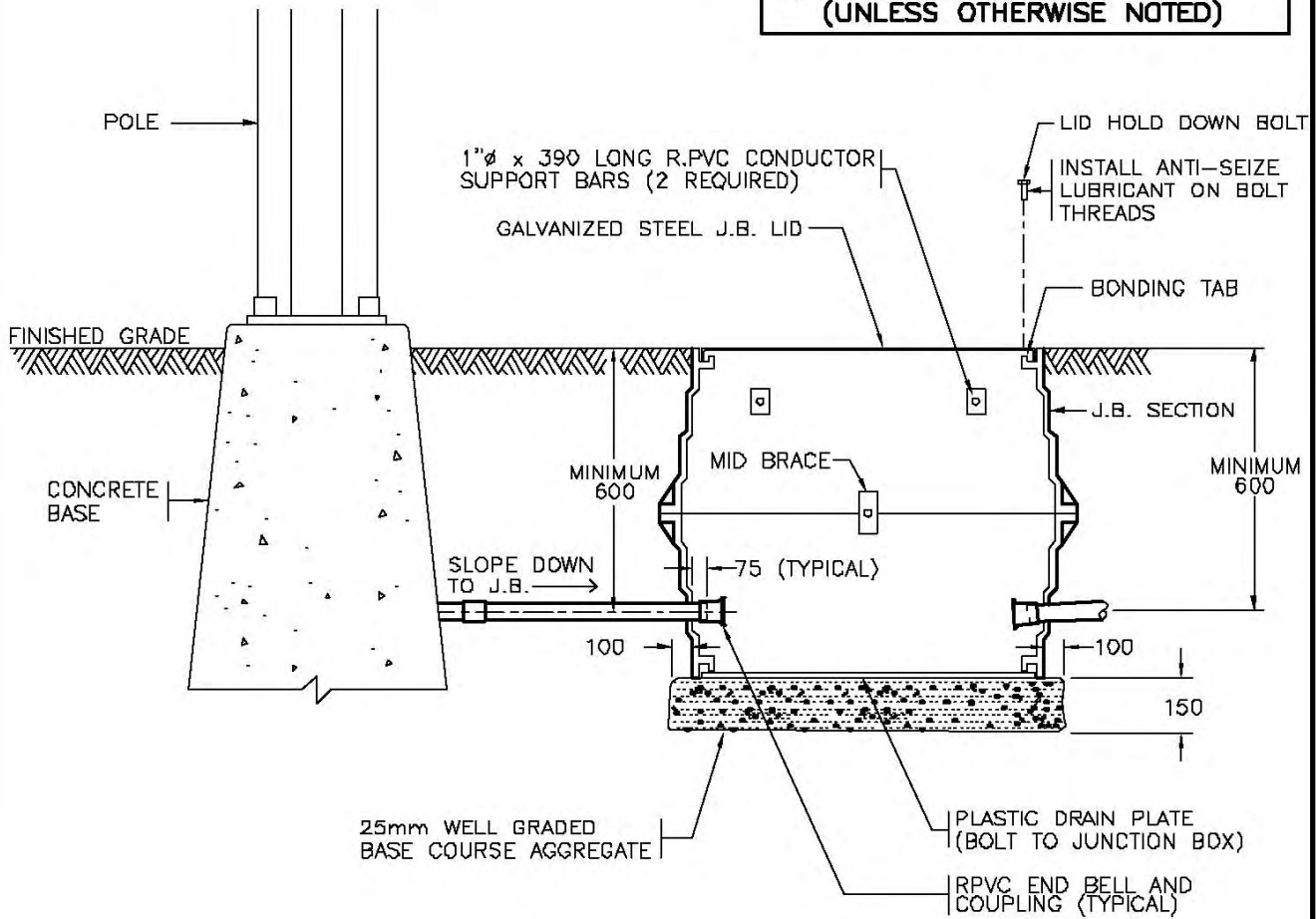

TYPE 6 JUNCTION BOX

- TWO J.B. SECTIONS (SN1847)
- ONE LID (SN1850)
- ONE MID BRACE (SN1857)
- ONE DRAIN PLATE (SN1859)

NOTES

1. SEE STANDARD SPECIFICATIONS & SPECIAL PROVISIONS FOR ADDITIONAL INFORMATION.
2. PLACE LID ON BOX & MID BRACE INSIDE BOX BEFORE BACKFILLING, TAMPING & PAVING OPERATIONS.
3. SEE DRAWINGS SP635-1.4.1, 1.4.2 & 1.4.3 FOR J.B. INSTALLATION DETAILS. aaaa
4. ALL CONDUITS SHALL DRAIN TO J.B.'S.
5. 'SN' DENOTES MINISTRY STOCK NUMBER.
6. ALL DIMENSIONS ARE IN MILLIMETRES UNLESS OTHERWISE NOTED.

NOT TO SCALE



No.	Revision	Date	TYPE 6 RECTANGULAR PLASTIC JUNCTION BOX INSTALLATION DETAILS	
E			Date	Approved
D				
C	LID HOLD DOWN BOLT & ANTI-SEIZE LUBRICANT NOTED	NOV 98	30/09/93	E.L. (Signature on File)
B	LID STOCK NUMBER REVISED	AUG 96	Chief Highway Engineer	
A	GENERAL REVISIONS	AUG 94	SPECIFICATION DRAWING No. SP635-1.2.1	

NUMBER OF CONDUITS ENTERING JUNCTION BOX NOT TO EXCEED 10 (UNLESS OTHERWISE NOTED)

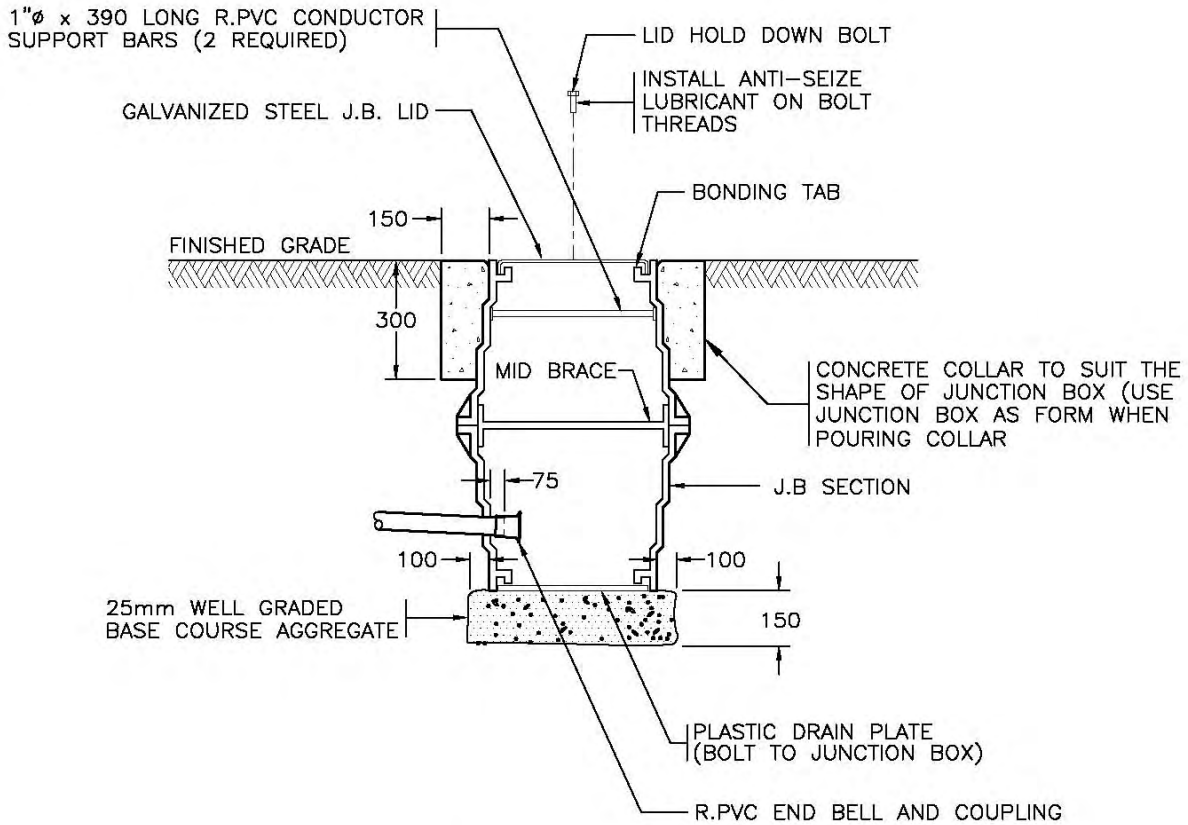

*** TYPE 6 'SPECIAL' JUNCTION BOX**

- TWO J.B. SECTIONS (SN1847)
- ONE LID (SN1850)
- ONE MID BRACE (SN1857)
- ONE DRAIN PLATE (SN1859)

NOTES

1. SEE STANDARD SPECIFICATIONS & SPECIAL PROVISIONS FOR ADDITIONAL INFORMATION.
2. PLACE LID ON BOX & MID BRACE INSIDE BOX BEFORE BACKFILLING, TAMPING & PAVING OPERATIONS.
3. SEE DRAWINGS SP635-1.4.1, 1.4.2 & 1.4.3 FOR J.B. INSTALLATION DETAILS. aaaa
4. ALL CONDUITS SHALL DRAIN TO J.B.'S.
5. 'SN' DENOTES MINISTRY STOCK NUMBER.
6. ALL DIMENSIONS ARE IN MILLIMETRES UNLESS OTHERWISE NOTED.

DENOTED AS 6* ON DRAWINGS

NOT TO SCALE



No.	Revision	Date	TYPE 6 'SPECIAL' RECTANGULAR PLASTIC JUNCTION BOX INSTALLATION DETAILS	
E				
D				
C	LID HOLD DOWN BOLT & ANTI-SEIZE LUBRICANT NOTED	NOV 98	Date	Approved
B	LID STOCK NUMBER REVISED	AUG 96	30/09/93	E.L. (Signature on File)
A	GENERAL REVISIONS	AUG 94	Chief Highway Engineer	
			SPECIFICATION DRAWING No. SP635-1.2.2	

NUMBER OF CONDUITS ENTERING JUNCTION BOX NOT TO EXCEED 10 (UNLESS OTHERWISE NOTED)

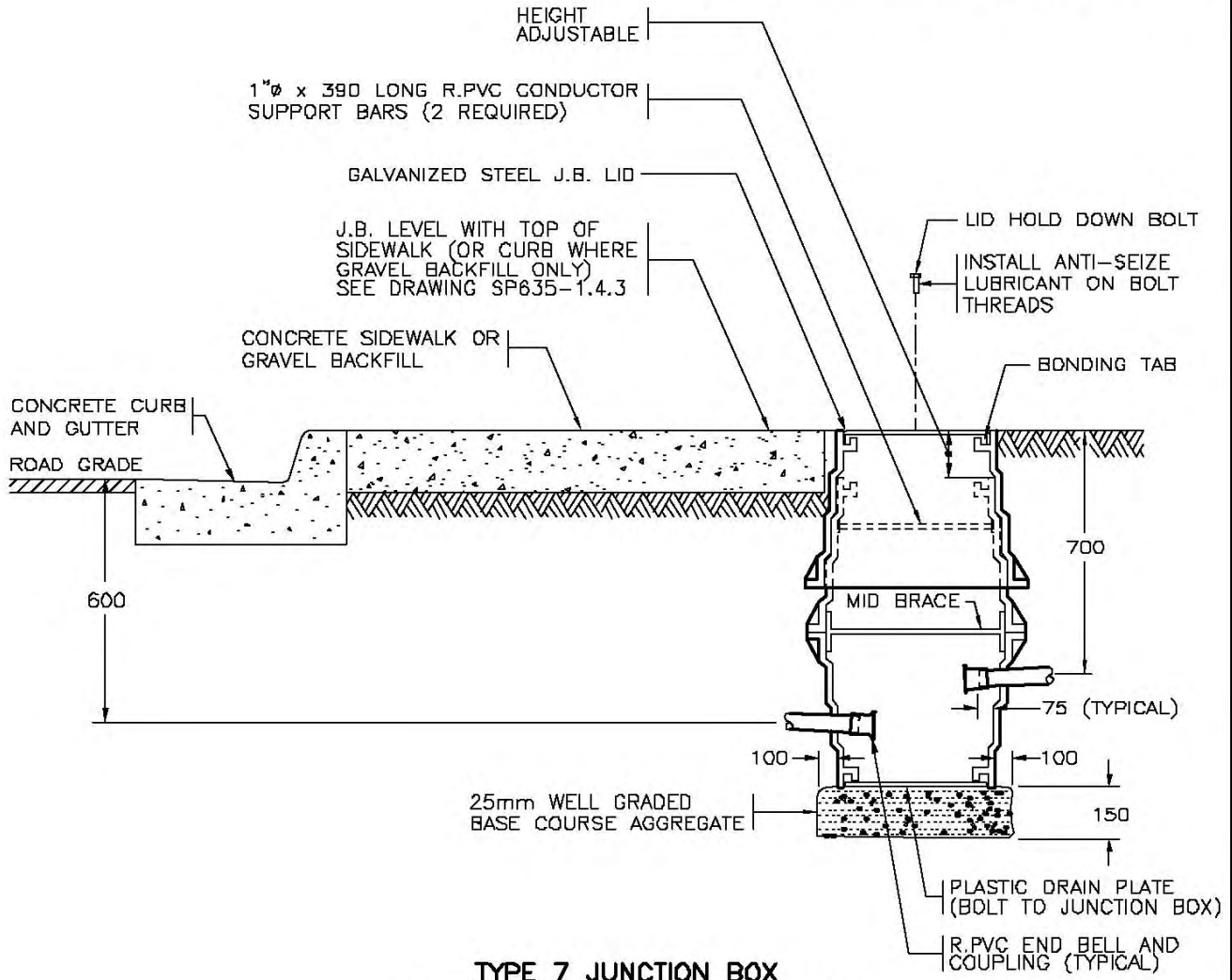

TYPE 7 JUNCTION BOX

THREE JUNCTION BOX SECTIONS (SN1847)
 ONE LID (SN1850)
 ONE MID BRACE (SN1857)
 ONE DRAIN PLATE (SN1859)

NOTES

1. SEE STANDARD SPECIFICATIONS & SPECIAL PROVISIONS FOR ADDITIONAL INFORMATION.
2. PLACE LID ON BOX & MID BRACE INSIDE BOX BEFORE BACKFILLING, TAMPING & PAVING OPERATIONS.
3. SEE DRAWINGS SP635-1.4.1, 1.4.2 & 1.4.3 FOR J.B. INSTALLATION DETAILS.
4. ALL CONDUITS SHALL DRAIN TO J.B.'S.
5. 'SN' DENOTES MINISTRY STOCK NUMBER.
6. ALL DIMENSIONS ARE IN MILLIMETRES UNLESS OTHERWISE NOTED.

aaaa



NOT TO SCALE

No.	Revision	Date	TYPE 7 RECTANGULAR PLASTIC JUNCTION BOX INSTALLATION DETAILS	
E				
D				
C	LID HOLD DOWN BOLT & ANTI-SEIZE LUBRICANT NOTED	NOV 98	Date	Approved
B	LID STOCK NUMBER REVISED	AUG 96	30/09/93	E.L. (Signature on File)
A	GENERAL REVISIONS	AUG 94		Chief Highway Engineer
			SPECIFICATION DRAWING No. SP635-1.2.3	

NUMBER OF CONDUITS ENTERING JUNCTION BDX NOT TO EXCEED 10 (UNLESS OTHERWISE NOTED)

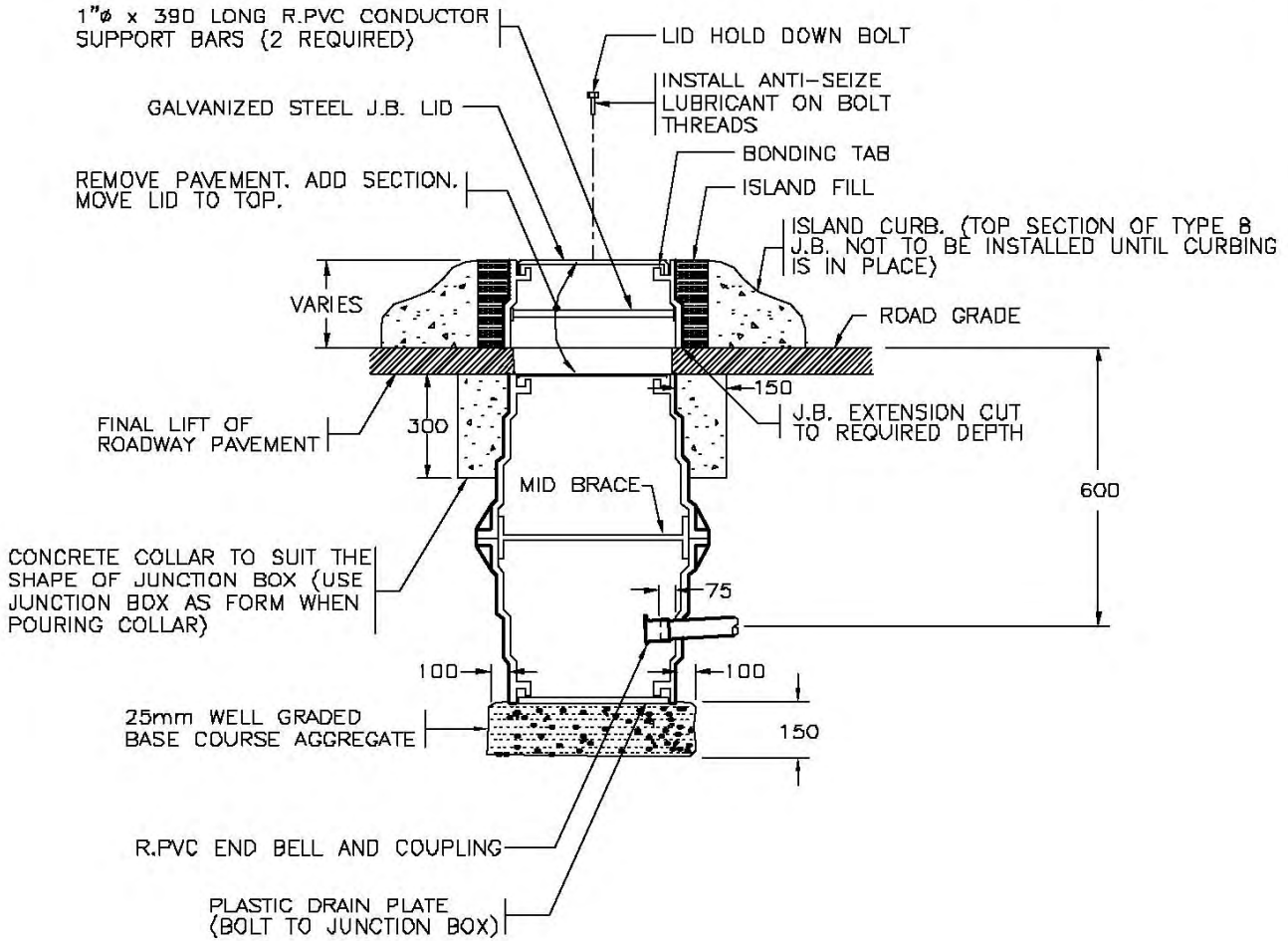

TYPE 8 JUNCTION BOX

THREE JUNCTION BOX SECTIONS (SN 1847)
 ONE LID (SN1850)
 ONE MID BRACE (SN1857)
 ONE DRAIN PLATE (SN1859)

NOTES

1. SEE STANDARD SPECIFICATIONS & SPECIAL PROVISIONS FOR ADDITIONAL INFORMATION.
2. PLACE LID ON BOX & MID BRACE INSIDE BOX BEFORE BACKFILLING, TAMPING & PAVING OPERATIONS.
3. SEE DRAWINGS SP635-1.4.1, 1.4.2 & 1.4.3 FOR J.B. INSTALLATION DETAILS.
4. ALL CONDUITS SHALL DRAIN TO J.B.'S.
5. 'SN' DENOTES MINISTRY STOCK NUMBER.
6. ALL DIMENSIONS ARE IN MILLIMETRES UNLESS OTHERWISE NOTED.

aaaa



NOT TO SCALE

No.	Revision	Date	TYPE 8 RECTANGULAR PLASTIC JUNCTION BOX INSTALLATION DETAILS		SPECIFICATION DRAWING No.
E			Date	Approved	SP635-1.2.4
D			30/09/93	E.L. (Signature on File)	
C	LID HOLD DOWN BOLT & ANTI-SEIZE LUBRICANT NOTED	NOV 98	Chief Highway Engineer		
B	LID STOCK NUMBER REVISED	AUG 96			
A	GENERAL REVISIONS	AUG 94			

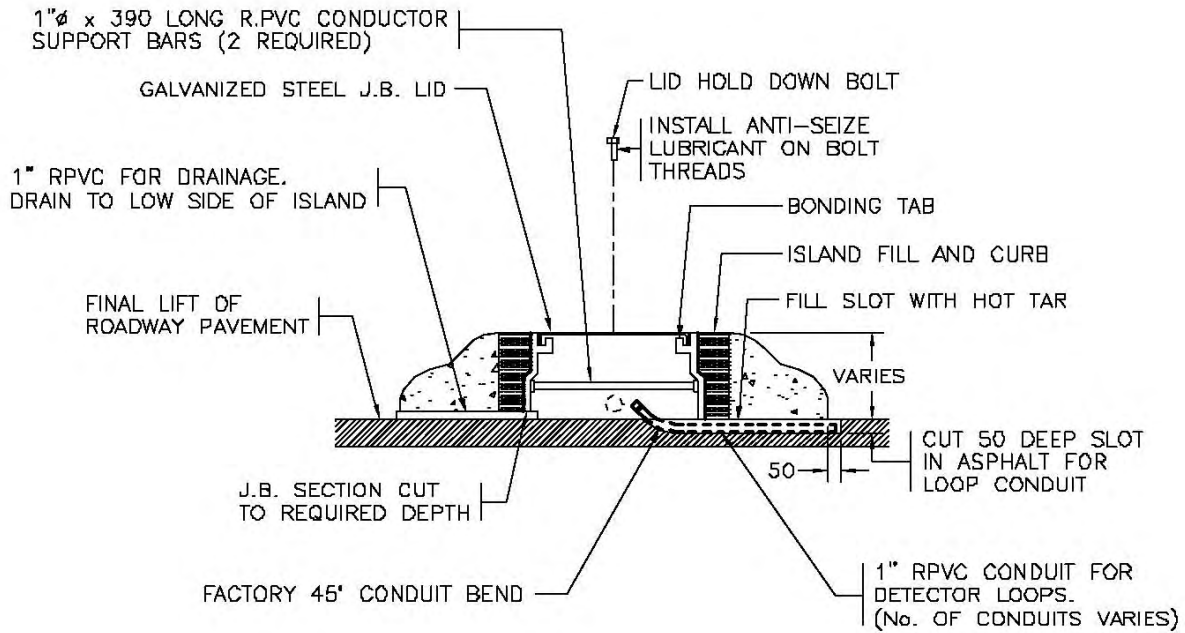

TYPE 9 JUNCTION BOX
 ONE JUNCTION BOX SECTION (SN1847)
 ONE LID (SN1850)

NOTES

1. SEE STANDARD SPECIFICATIONS & SPECIAL PROVISIONS FOR ADDITIONAL INFORMATION.
2. PLACE LID ON BOX & MID BRACE INSIDE BOX BEFORE BACKFILLING, TAMPING & PAVING OPERATIONS.
3. SEE DRAWINGS SP635-1.4.1, 1.4.2 & 1.4.3 FOR J.B. INSTALLATION DETAILS. aaaa
4. ALL CONDUITS SHALL DRAIN TO J.B.'S.
5. 'SN' DENOTES MINISTRY STOCK NUMBER.
6. ALL DIMENSIONS ARE IN MILLIMETRES UNLESS OTHERWISE NOTED.

NOT TO SCALE



No.	Revision	Date	TYPE 9 RECTANGULAR PLASTIC JUNCTION BOX INSTALLATION DETAILS		SPECIFICATION DRAWING No.
E			Date	Approved	SP635-1.2.5
D			30/09/93	E.L. (Signature on File)	
C	LID HOLD DOWN BOLT & ANTI-SEIZE LUBRICANT NOTED	NOV 98	Chief Highway Engineer		
B	LID STOCK NUMBER REVISED	AUG 96			
A	GENERAL REVISIONS	AUG 94			

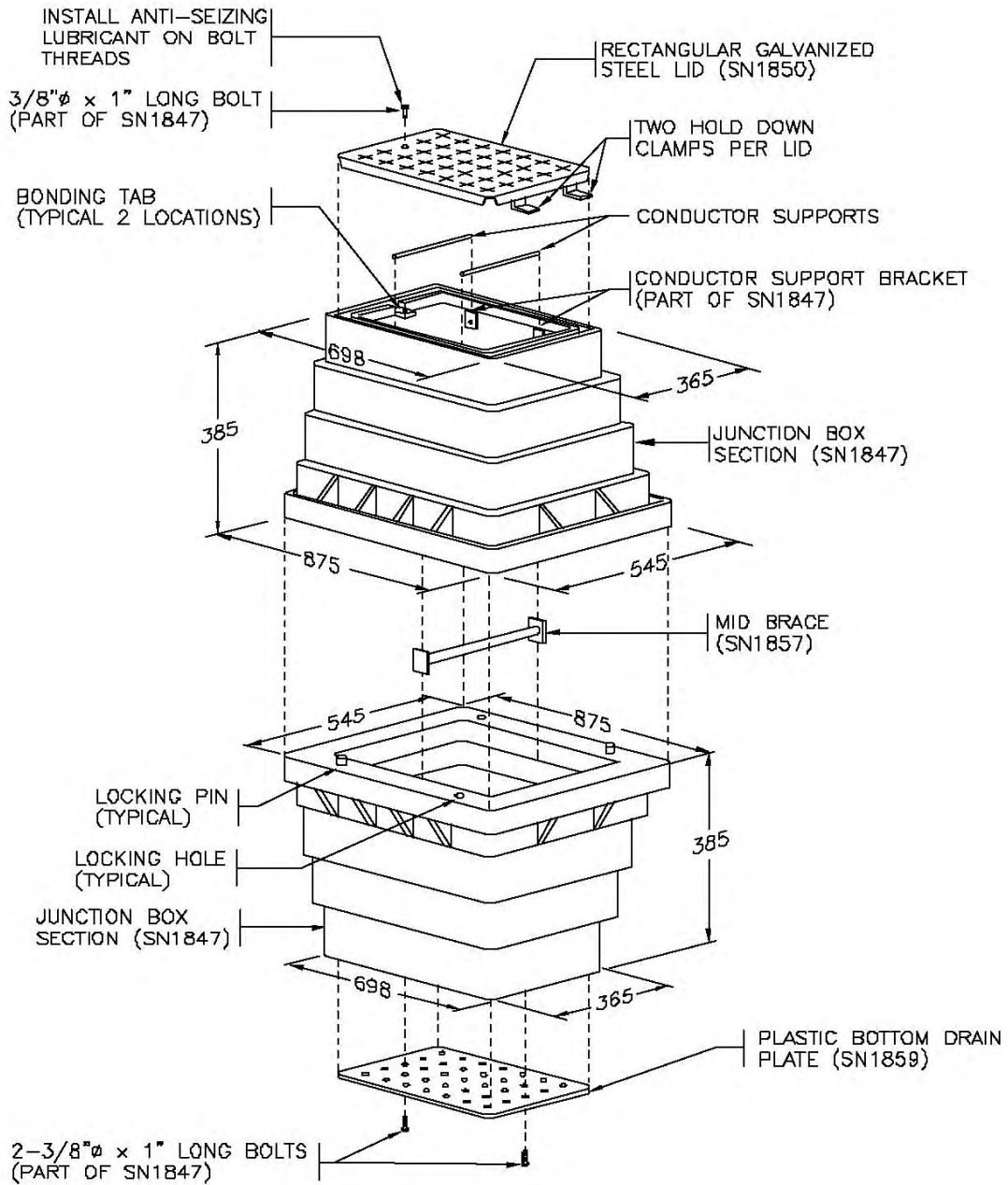

NOTES

1. SEE STANDARD SPECIFICATIONS & SPECIAL PROVISIONS FOR ADDITIONAL INFORMATION.
2. PLACE LID ON BOX & MID BRACE INSIDE BOX BEFORE BACKFILLING, TAMPING & PAVING OPERATIONS.
3. SEE DRAWINGS SP635-1.4.1, 1.4.2 & 1.4.3 FOR J.B. INSTALLATION DETAILS.
4. ALL CONDUITS SHALL DRAIN TO J.B.'S.
5. 'SN' DENOTES MINISTRY STOCK NUMBER.
6. ALL DIMENSIONS ARE IN MILLIMETRES UNLESS OTHERWISE NOTED.

aaaa



NOT TO SCALE

No.	Revision	Date
F		
E		
D		
C	ANTI-SEIZING LUBRICANT NOTED	NOV 98
B	LID STOCK NUMBER REVISED	AUG 96
A	GENERAL REVISIONS	AUG 94

RECTANGULAR PLASTIC JUNCTION BOX DETAILS		
Date	Approved	SPECIFICATION DRAWING No.
30/09/93	E.L. (Signature on File) Chief Highway Engineer	SP635-1.2.6

NUMBER OF CONDUITS ENTERING JUNCTION BOX NOT TO EXCEED 10 (UNLESS OTHERWISE NOTED)

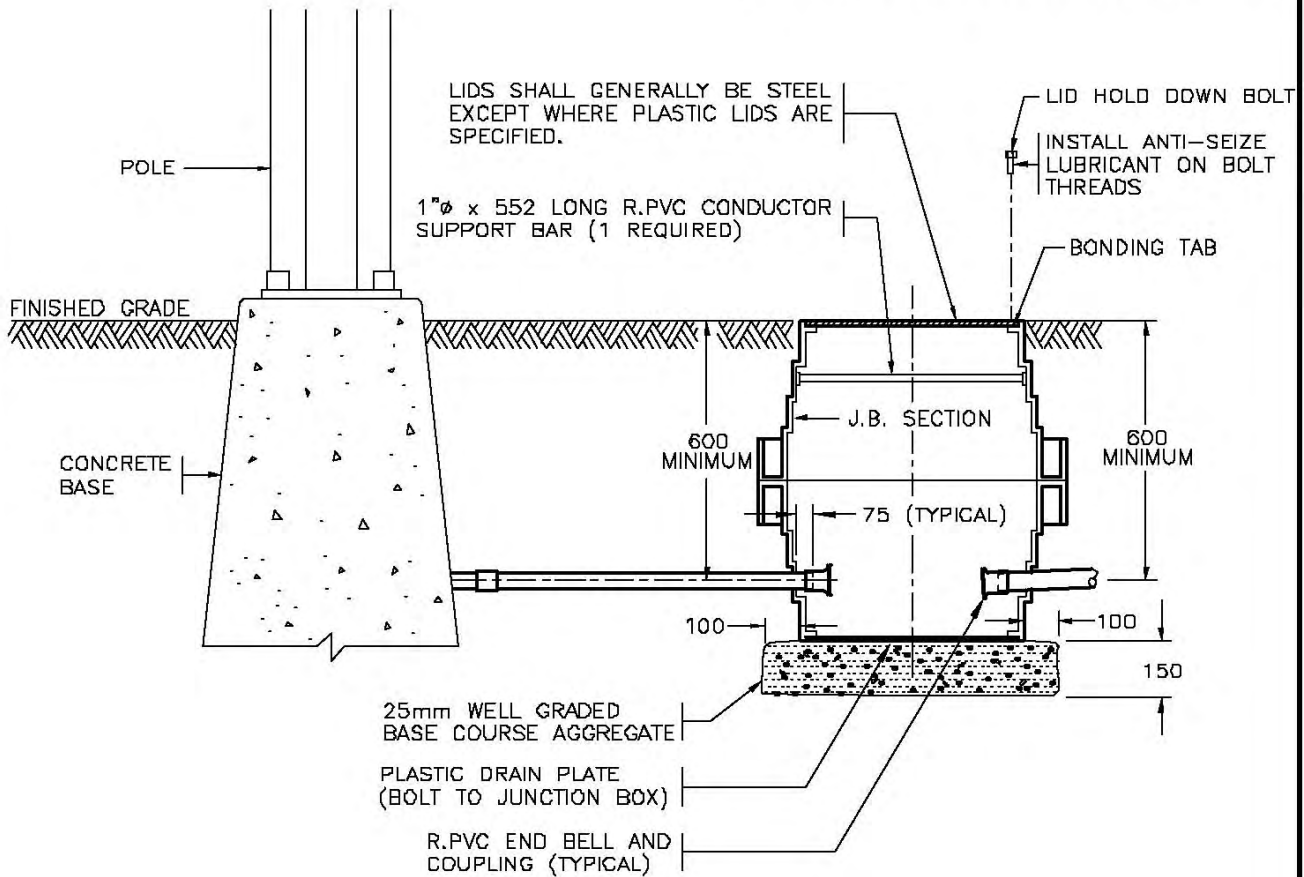

TYPE 10 JUNCTION BOX

TWO J.B. SECTIONS (SN1847R)
 ONE PLASTIC LID (SN1850R) OR ONE STEEL LID (SN184B)
 ONE DRAIN PLATE (SN1849)

NOTES

1. SEE STANDARD SPECIFICATIONS & SPECIAL PROMSIONS FOR ADDITIONAL INFORMATION.
2. BOLT DOWN LID ON BOX BEFORE BACKFILLING, TAMPING & PAVING OPERATIONS.
3. SEE DRAWINGS SP635-1.4.1, 1.4.2 & 1.4.3 FOR J.B. INSTALLATION DETAILS.
4. ALL CONDUITS SHALL DRAIN TO J.B.'S aaaa
5. 'SN' DENOTES MINISTRY STOCK NUMBER.
6. ALL DIMENSIONS ARE IN MILLIMETRES UNLESS OTHERWISE NOTED.



NOT TO SCALE

No.	Revision	Date	TYPE 10 ROUND PLASTIC JUNCTION BOX INSTALLATION DETAILS		SPECIFICATION DRAWING No.
E			Date	Approved	SP635-1.2.7
D			30/09/93	E.L. (Signature on File)	
C	LID HOLD DOWN BOLT & ANTI-SEIZE LUBRICANT NOTED	NOV 98	Chief Highway Engineer		
B	LID & DRAIN PLATE STOCK NUMBER REVISED	AUG 96			
A	GENERAL REVISIONS	AUG 94			

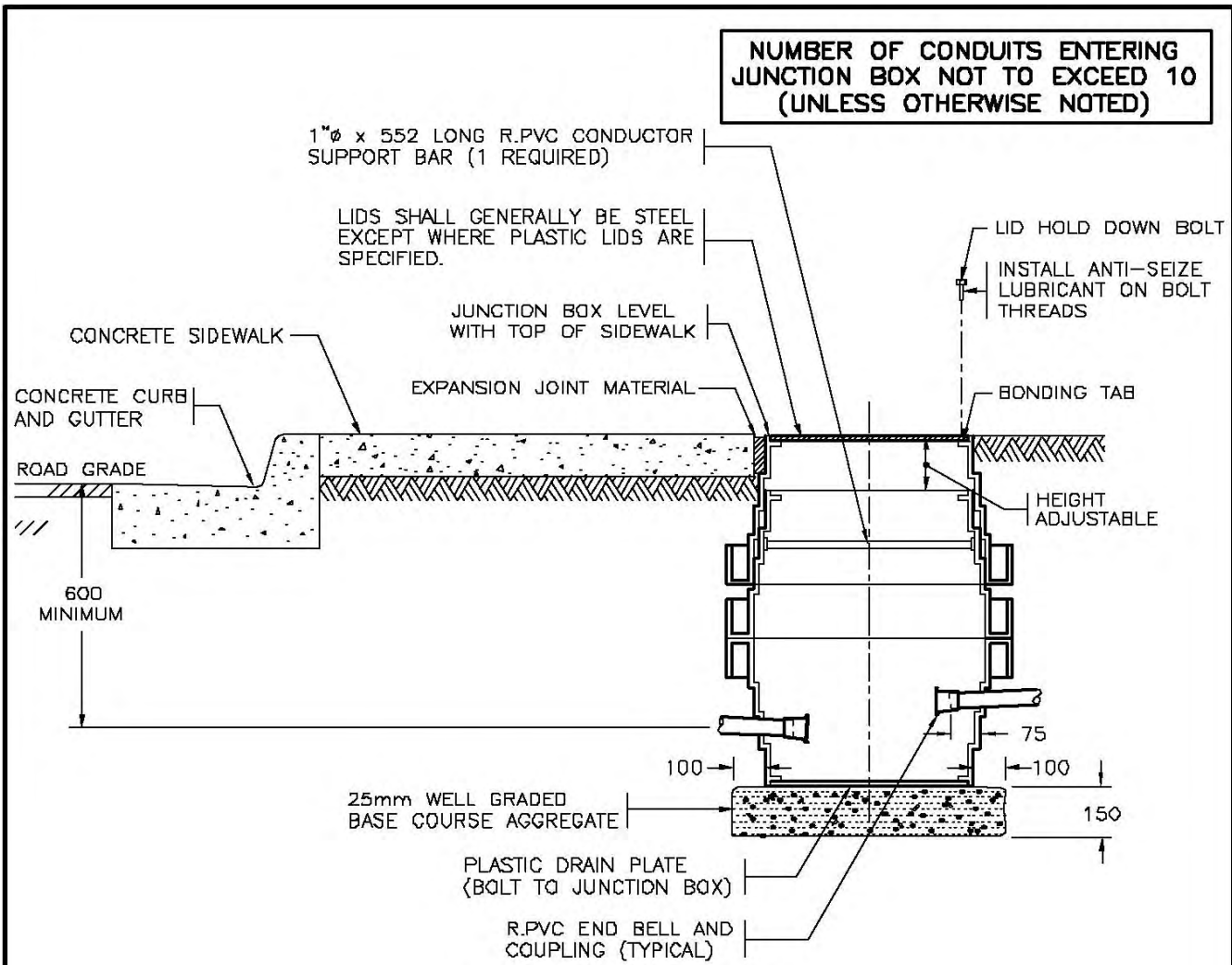

TYPE 11 JUNCTION BOX

THREE JUNCTION BOX SECTIONS (SN1847R)
 ONE PLASTIC LID (SN1850R) OR ONE STEEL LID (SN1848)
 ONE DRAIN PLATE (SN1849)

NOTES

1. SEE STANDARD SPECIFICATIONS & SPECIAL PROVISIONS FOR ADDITIONAL INFORMATION.
2. BOLT DOWN LID ON BOX BEFORE BACKFILLING, TAMPING & PAVING OPERATIONS.
3. SEE DRAWINGS SP635-1.4.1, 1.4.2 & 1.4.3 FOR J.B. INSTALLATION DETAILS.
4. ALL CONDUITS SHALL DRAIN TO J.B.'S
5. 'SN' DENOTES MINISTRY STOCK NUMBER.
6. ALL DIMENSIONS ARE IN MILLIMETRES UNLESS OTHERWISE NOTED.

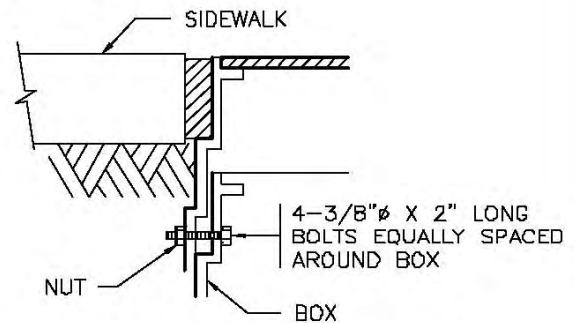

JUNCTION BOX IN SIDEWALK



NOT TO SCALE

No.	Revision	Date	TYPE 11 ROUND PLASTIC JUNCTION BOX INSTALLATION DETAILS		SPECIFICATION DRAWING No.
E	DETAIL REVISED	APR 05	Date	Approved	SP635-1.2.8
D	DETAIL ADDED	OCT 03	30/09/93	E.L. (Signature on File)	
C	LID HOLD DOWN BOLT & ANTI-SEIZE LUBRICANT NOTED	NOV 98	Chief Highway Engineer		
B	LID & DRAIN PLATE STOCK NUMBER REVISED	AUG 96			
A	GENERAL REVISIONS	AUG 94			

NUMBER OF CONDUITS ENTERING JUNCTION BOX NOT TO EXCEED 10 (UNLESS OTHERWISE NOTED)

1"Ø x 552 LONG R.PVC CONDUCTOR SUPPORT BAR (1 REQUIRED)

LIDS SHALL GENERALLY BE STEEL EXCEPT WHERE PLASTIC LIDS ARE SPECIFIED.

REMOVE PAVEMENT. ADD SECTION. MOVE LID AND BRACE TO TOP.

LID HOLD DOWN BOLT
INSTALL ANTI-SEIZE LUBRICANT ON BOLT THREADS

BONDING TAB
ISLAND FILL

ISLAND CURB. (TOP SECTION OF TYPE 12 JUNCTION BOX NOT TO BE INSTALLED UNTIL CURBING IS IN PLACE)

VARIES

ROAD GRADE

PAVEMENT

JUNCTION BOX EXTENSION CUT TO REQUIRED DEPTH

600 MINIMUM

25mm WELL GRADED BASE COURSE AGGREGATE

PLASTIC DRAIN PLATE (BOLT TO JUNCTION BOX)

R.PVC END BELL AND COUPLING

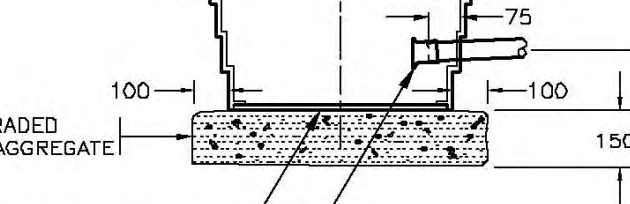

TYPE 12 JUNCTION BOX

THREE JUNCTION BOX SECTIONS (SN1847R)
ONE PLASTIC LID (SN1850R) OR ONE STEEL LID (SN184B)
ONE DRAIN PLATE (SN1849)

NOTES

1. SEE STANDARD SPECIFICATIONS & SPECIAL PROVISIONS FOR ADDITIONAL INFORMATION.
2. BOLT DOWN LID ON BOX BEFORE BACKFILLING, TAMPING & PAVING OPERATIONS.
3. SEE DRAWINGS SP635-1.4.1, 1.4.2 & 1.4.3 FOR J.B. INSTALLATION DETAILS.
4. ALL CONDUITS SHALL DRAIN TO J.B.'S aaaa
5. 'SN' DENOTES MINISTRY STOCK NUMBER.
6. ALL DIMENSIONS ARE IN MILLIMETRES UNLESS OTHERWISE NOTED.



NOT TO SCALE

No.	Revision	Date	TYPE 12 ROUND PLASTIC JUNCTION BOX INSTALLATION DETAILS		SPECIFICATION DRAWING No.
E			Date	Approved	SP635-1.2.9
D			30/09/93	E.L. (Signature on File)	
C	LID HOLD DOWN BOLT & ANTI-SEIZE LUBRICANT NOTED	NOV 98	Chief Highway Engineer		
B	LID & DRAIN PLATE STOCK NUMBER REVISED	AUG 96			
A	GENERAL REVISIONS	AUG 94			

1"Ø x 552 LDNG R.PVC CONDUCTOR
SUPPORT BAR (1 REQUIRED)

LIDS SHALL GENERALLY BE STEEL
EXCEPT WHERE PLASTIC LIDS ARE
SPECIFIED.

1" R.PVC FOR DRAINAGE.
DRAIN TO LOW SIDE OF ISLAND

J.B. SECTION CUT
TO REQUIRED DEPTH

FACTORY 45° CONDUIT BEND

LID HOLD DOWN BOLT

INSTALL ANTI-SEIZE
LUBRICANT ON BOLT
THREADS

BONDING TAB

ISLAND FILL AND CURB

VARIES

CUT 50 DEEP SLOT
IN ASPHALT FOR
LOOP CONDUIT

1" RPVC CONDUIT FOR
DETECTOR LOOPS.
(No. OF CONDUITS VARIES)

TYPE 13 JUNCTION BOX

ONE JUNCTION BOX SECTION (SN1847R)
ONE PLASTIC LID (SN1850R) OR ONE STEEL LID (SN1848)

NOTES

1. SEE STANDARD SPECIFICATIONS & SPECIAL PROMSIONS FOR ADDITIONAL INFORMATION.
2. BOLT DOWN LID ON BOX BEFORE BACKFILLING, TAMPING & PAVING OPERATIONS.
3. SEE DRAWINGS SP635-1.4.1, 1.4.2 & 1.4.3 FOR J.B. INSTALLATION DETAILS.
4. ALL CONDUITS SHALL DRAIN TO J.B.'S aaaa
5. 'SN' DENOTES MINISTRY STOCK NUMBER.
6. ALL DIMENSIONS ARE IN MILLIMETRES UNLESS OTHERWISE NOTED.

NOT TO SCALE



No.	Revision	Date	TYPE 13 ROUND PLASTIC JUNCTION BOX INSTALLATION DETAILS		SPECIFICATION DRAWING No.
E			Date	Approved	SP635-1.2.10
D	LID HOLD DOWN BOLT & ANTI-SEIZE LUBRICANT NOTED	NOV 98	30/09/93	E.L. (Signature on File) Chief Highway Engineer	
C	STEEL LID STOCK NUMBER REVISED	AUG 96			
B	STEEL LID TYPE NOTE CHANGED	AUG 95			
A	GENERAL REVISIONS	AUG 94			

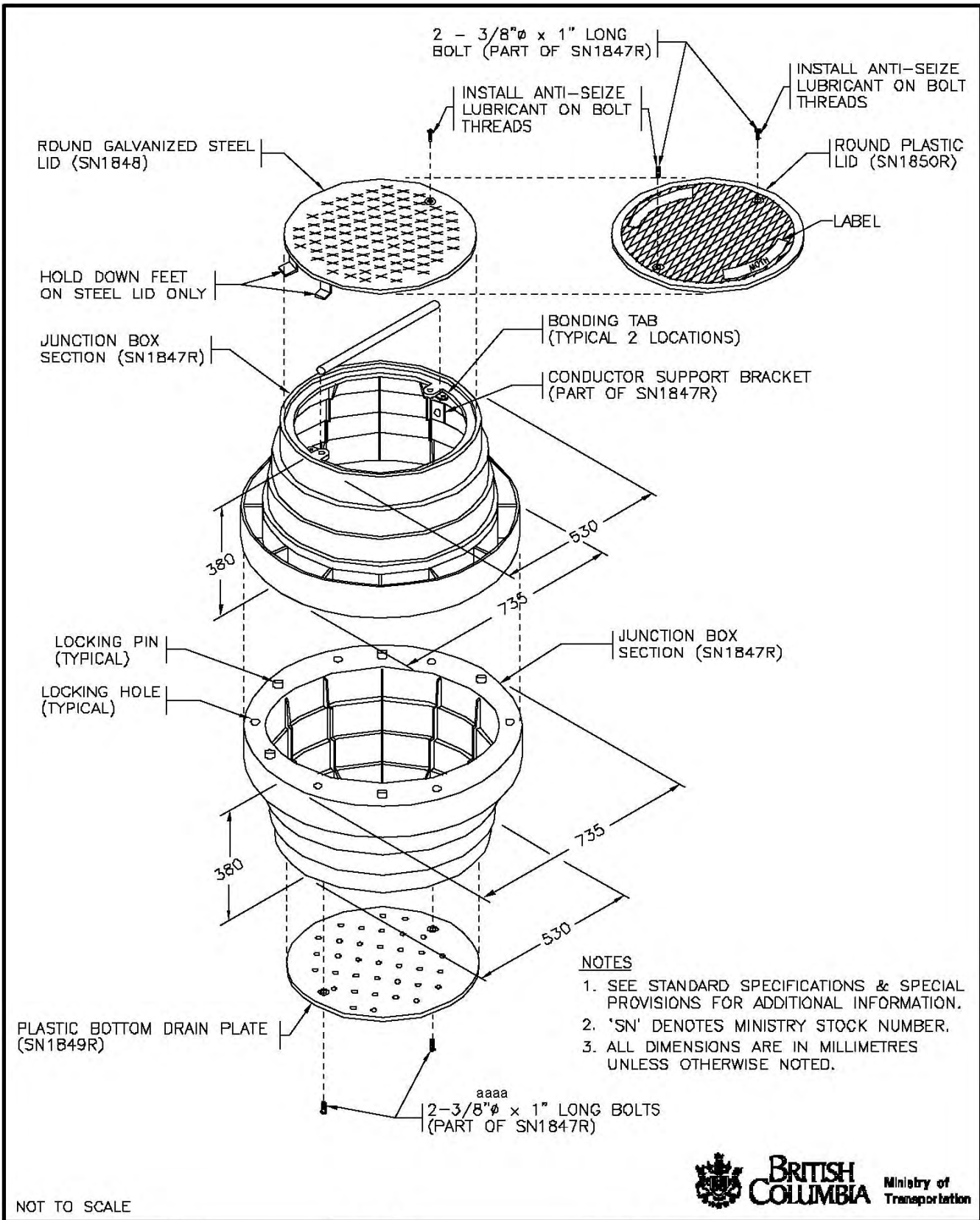

NOTES

1. SEE STANDARD SPECIFICATIONS & SPECIAL PROVISIONS FOR ADDITIONAL INFORMATION.
2. 'SN' DENOTES MINISTRY STOCK NUMBER.
3. ALL DIMENSIONS ARE IN MILLIMETRES UNLESS OTHERWISE NOTED.

NOT TO SCALE



No.	Revision	Date
F		
E		
D	ANTI-SEIZING LUBRICANT NOTED	NOV 98
C	STEEL LID STOCK NUMBER REVISED	AUG 96
B	STEEL LID REVISED	AUG 95
A	GENERAL REVISIONS	AUG 94

ROUND PLASTIC JUNCTION BOX DETAILS		
Date	Approved	SPECIFICATION DRAWING No.
30/09/93	E.L. (Signature on File) Chief Highway Engineer	SP635-1.2.11

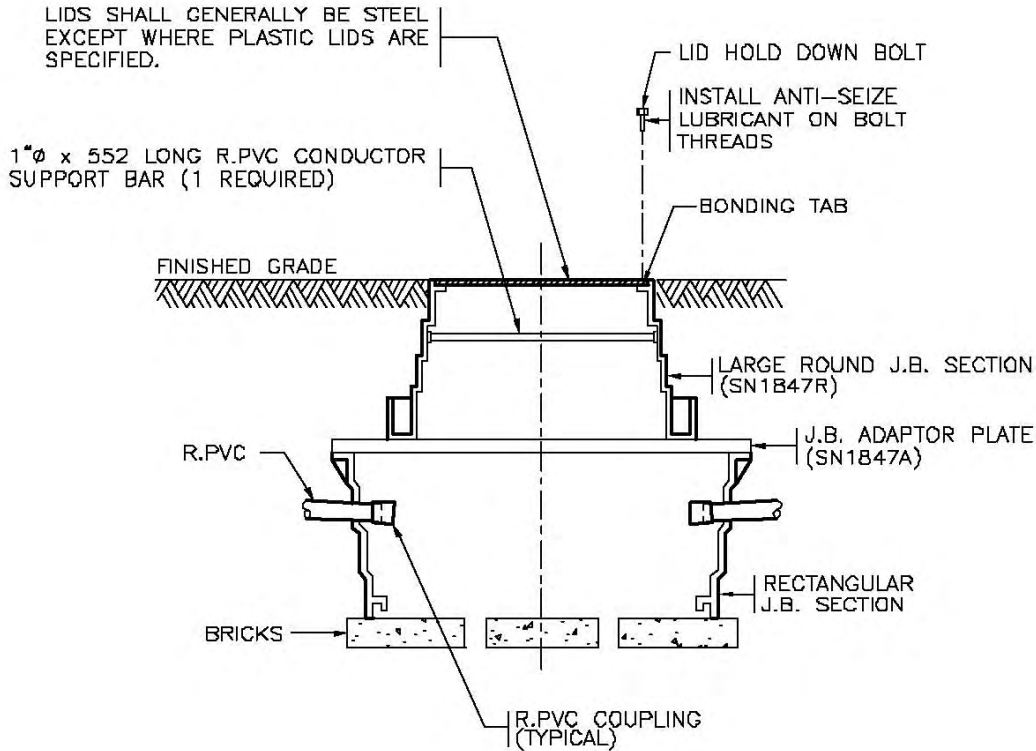

JUNCTION BOX

- ONE J.B. SECTION (SN1847R)
- ONE PLASTIC LID (SN1850R) OR ONE STEEL LID (SN184B)
- ONE J.B. ADAPTOR (SN1847A)

NOTES

1. SEE STANDARD SPECIFICATIONS & SPECIAL PROVISIONS FOR ADDITIONAL INFORMATION.
2. BOLT DOWN LID ON BOX BEFORE BACKFILLING, TAMPING & PAVING OPERATIONS. aaaa
3. 'SN' DENOTES MINISTRY STOCK NUMBER.
4. ALL DIMENSIONS ARE IN MILLIMETRES UNLESS OTHERWISE NOTED.

NOT TO SCALE



No.	Revision	Date	RECTANGULAR TO ROUND PLASTIC JUNCTION BOX INSTALLATION DETAILS		SPECIFICATION DRAWING No.
E			Date	Approved	SP635-1.2.12
D			30/09/93	E.L. (Signature on File)	
C	LID HOLD DOWN BOLT & ANTI-SEIZE LUBRICANT NOTED	NOV 98	Chief Highway Engineer		
B	LID & JUNCTION BOX STOCK NUMBER REVISED	AUG 96			
A	GENERAL REVISIONS	AUG 94			

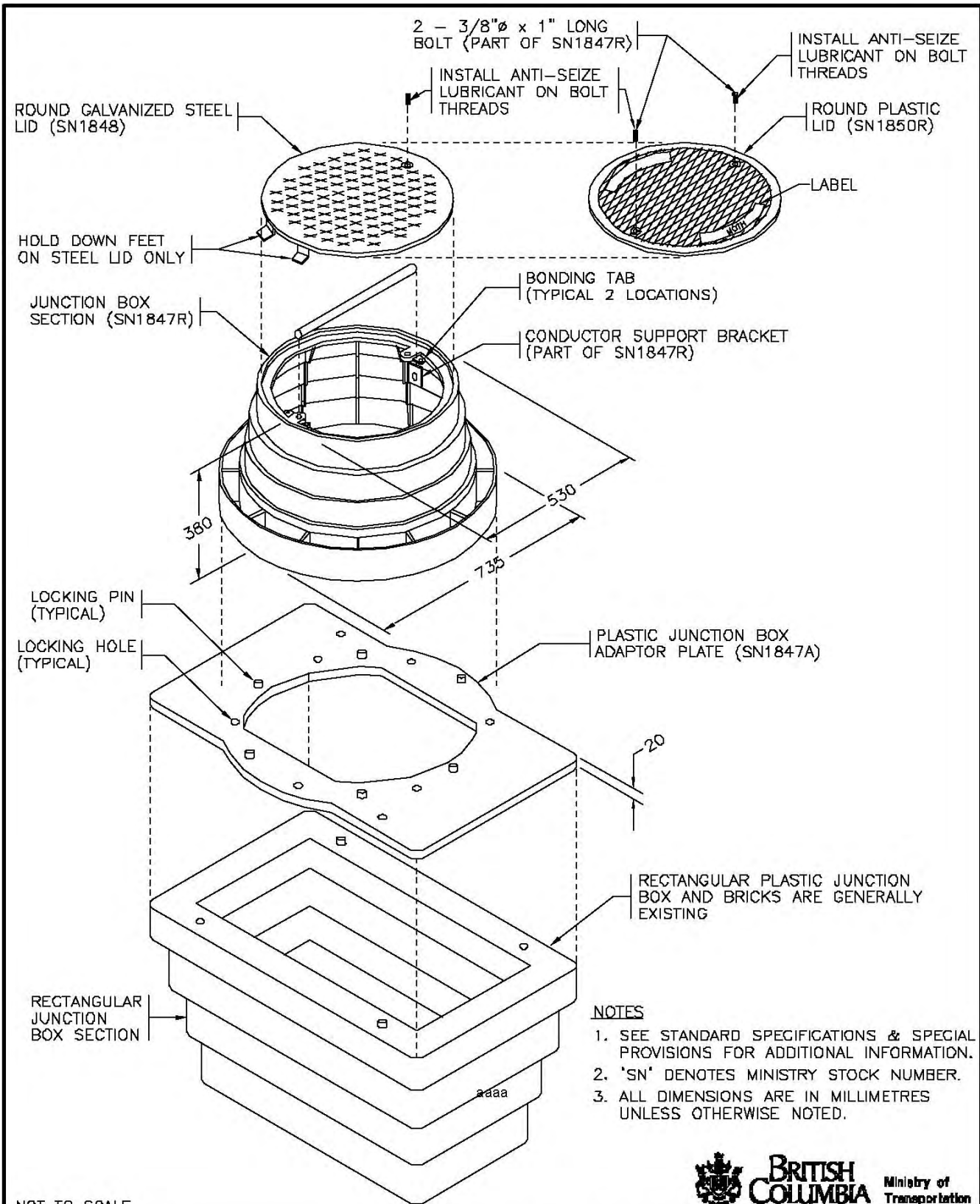

NOT TO SCALE



No.	Revision	Date
F		
E		
D	ANTI-SEIZING LUBRICANT NOTED	NOV 98
C	LID STOCK NUMBER REVISED	AUG 96
B	STEEL LID REVISED	AUG 95
A	GENERAL REVISIONS	AUG 94

RECTANGULAR TO ROUND
PLASTIC JUNCTION BOX ADAPTOR DETAILS

Date: 30/09/93
Approved: E.L. (Signature on File)
Chief Highway Engineer

SPECIFICATION
DRAWING No.
SP635-1.2.13

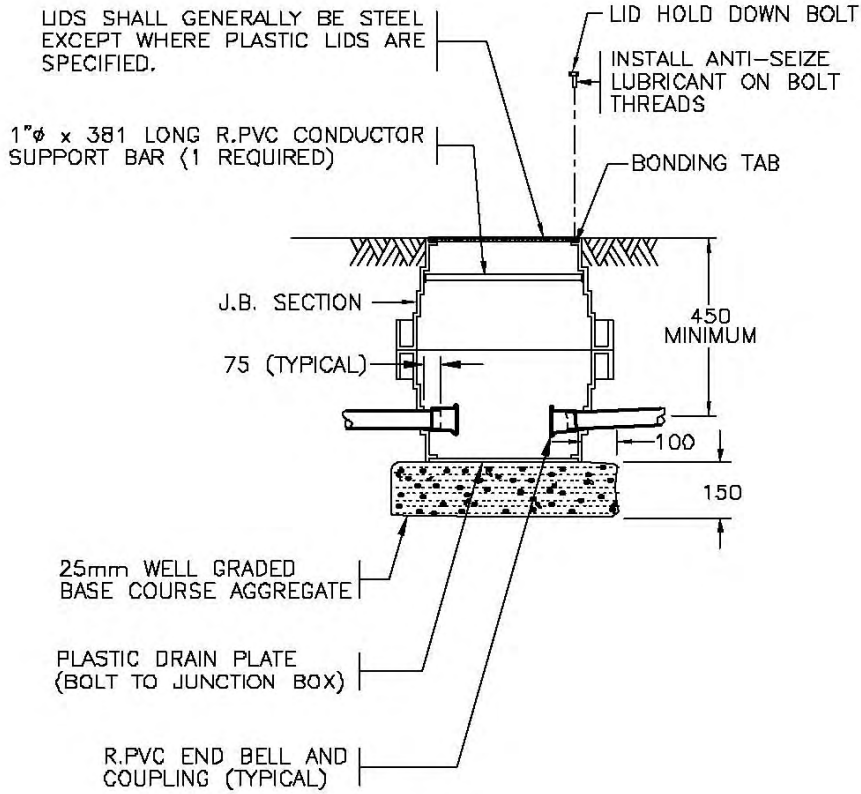

TYPE 14 JUNCTION BOX

TWO J.B. SECTIONS (SN1853)
 ONE PLASTIC LID (SN1853A) OR ONE STEEL LID (SN1853B)
 ONE DRAIN PLATE (SN1853C)

NOTES

1. SEE STANDARD SPECIFICATIONS & SPECIAL PROVISIONS FOR ADDITIONAL INFORMATION.
2. BOLT DOWN LID ON BOX BEFORE BACKFILLING, TAMPING & PAVING OPERATIONS.
3. ALL CONDUITS SHALL DRAIN TO J.B.'S aaaa
4. 'SN' DENOTES MINISTRY STOCK NUMBER.
5. ALL DIMENSIONS ARE IN MILLIMETRES UNLESS OTHERWISE NOTED.

NOT TO SCALE



No.	Revision	Date	TYPE 14 SMALL ROUND PLASTIC JUNCTION BOX INSTALLATION DETAILS	
E			Date	Approved
D				
C				
B				
A	LID HOLD DOWN BOLT & ANTI-SEIZE LUBRICANT NOTED	NOV 98	17/11/94	E.L. (Signature on File) Chief Highway Engineer
			SPECIFICATION DRAWING No. SP635-1.2.14	

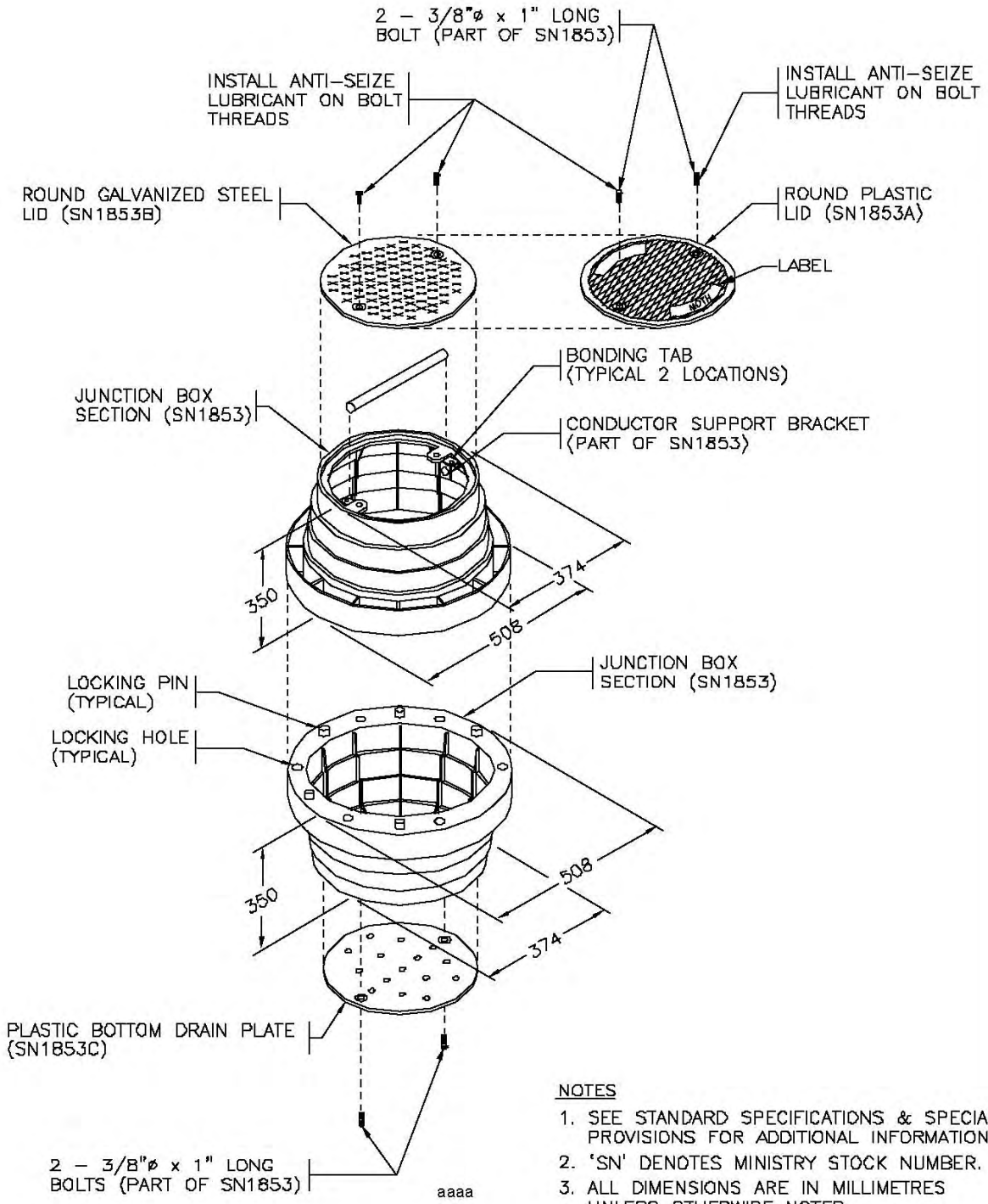

- NOTES**
1. SEE STANDARD SPECIFICATIONS & SPECIAL PROVISIONS FOR ADDITIONAL INFORMATION.
 2. 'SN' DENOTES MINISTRY STOCK NUMBER.
 3. ALL DIMENSIONS ARE IN MILLIMETRES UNLESS OTHERWISE NOTED.



NOT TO SCALE

No.	Revision	Date	SMALL ROUND PLASTIC JUNCTION BOX DETAILS		SPECIFICATION DRAWING No.
E			Date	Approved	SP635-1.2.15
D			17/11/94	E.L. (Signature on File)	
C				Chief Highway Engineer	
B					
A	LID HOLD DOWN BOLT & ANTI-SEIZE LUBRICANT NOTED	NOV 98			

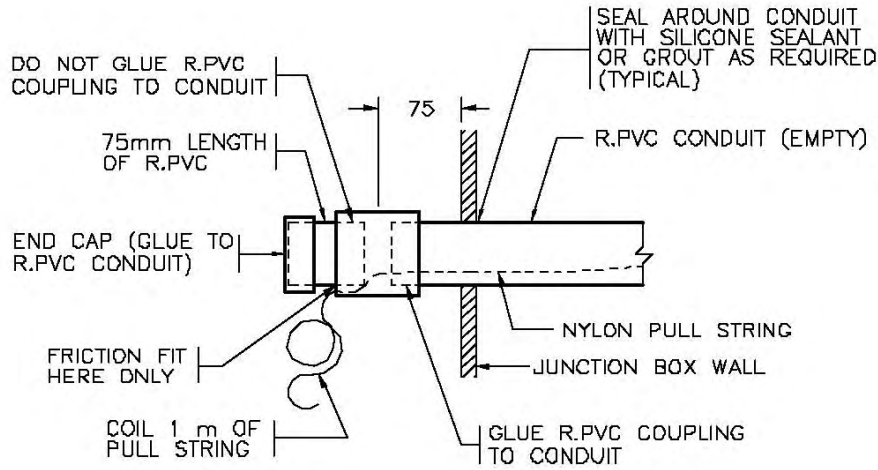

CAPPED EMPTY CONDUIT ENTRY TO JUNCTION BOX

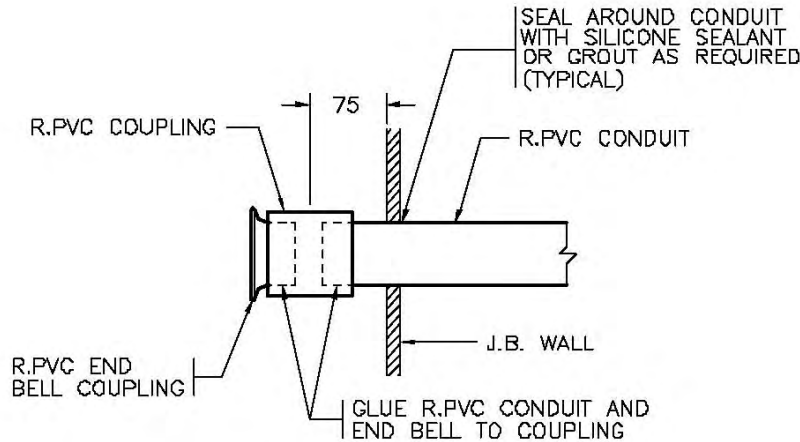

NOTE: ALL CONDUITS TO DRAIN TO J.B.

CONDUIT ENTRY TO J.B.

NOTES

1. SEE STANDARD SPECIFICATIONS & SPECIAL PROVISIONS FOR ADDITIONAL INFORMATION.
2. ALL DIMENSIONS ARE IN MILLIMETRES UNLESS OTHERWISE NOTED.
3. PULL STRING SHALL BE POLYPROPYLENE WITH A MINIMUM TENSILE STRENGTH OF 1.1kN. (BC HYDRO SPEC.)

aaaa

NOT TO SCALE



No.	Revision	Date	CONDUIT ENTRY INTO PLASTIC JUNCTION BOXES	
F			Date	Approved
E			30/09/93	E.L. (Signature on File)
D			Chief Highway Engineer	
C	NOTE 3 ADDED	NOV 98	SPECIFICATION DRAWING No. SP635-1.2.16	
B	CONDUIT GLUING CLARIFIED	OCT 97		
A	GENERAL REVISIONS	AUG 94		

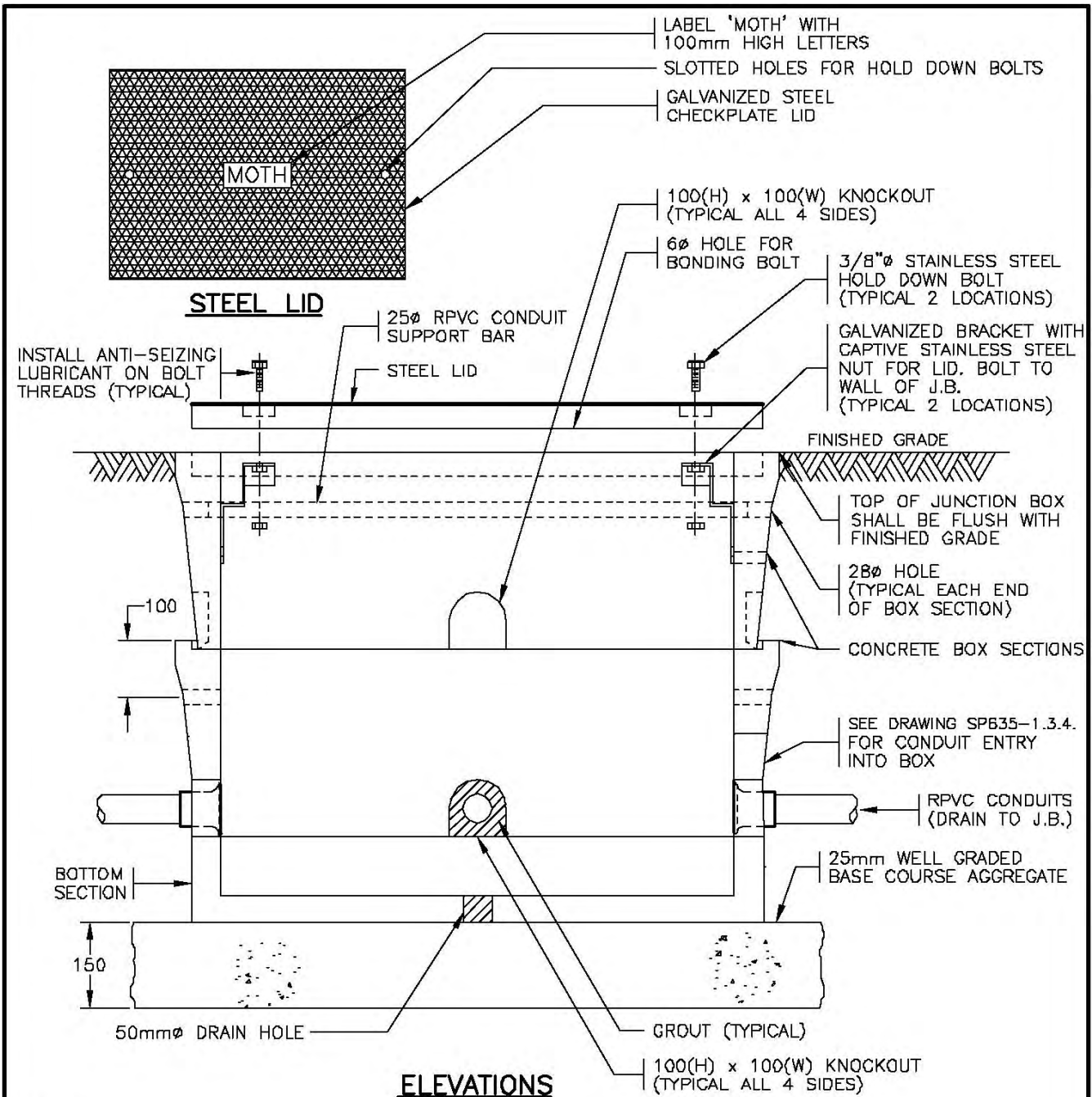

ELEVATIONS

NOTES

1. SEE STANDARD SPECIFICATIONS & SPECIAL PROVISIONS FOR ADDITIONAL INFORMATION.
2. JUNCTION BOX SHALL BE 'A.E. CONCRETE PRODUCTS LTD' No. MOTH 5686 OR APPROVED ALTERNATIVE. aaaa
3. JUNCTION BOX SHALL BE DESIGNED FOR 5000kg STATIC LOADING.
4. VAULTS SHALL BE PRE-CAST CONCRETE WITH A MINIMUM COMPRESSIVE STRENGTH OF 35 MPa AT 28 DAYS.
5. ALL DIMENSIONS ARE IN MILLIMETRES UNLESS OTHERWISE NOTED. NOT TO SCALE



No.	Revision	Date
F		
E	GENERAL REVISIONS	APR 05
D	KON KAST PRODUCT DELETED	OCT 03
C	ANTI-SEIZING LUBRICANT NOTED	NOV 98
B	LID HOLD DOWN REVISED	AUG 96
A	STEEL INSERTS ADDED	AUG 95

CONCRETE JUNCTION BOX DETAILS		
Date	Approved	SPECIFICATION DRAWING No.
18/11/94	E.L. (Signature on File) Chief Highway Engineer	SP635-1.3.1

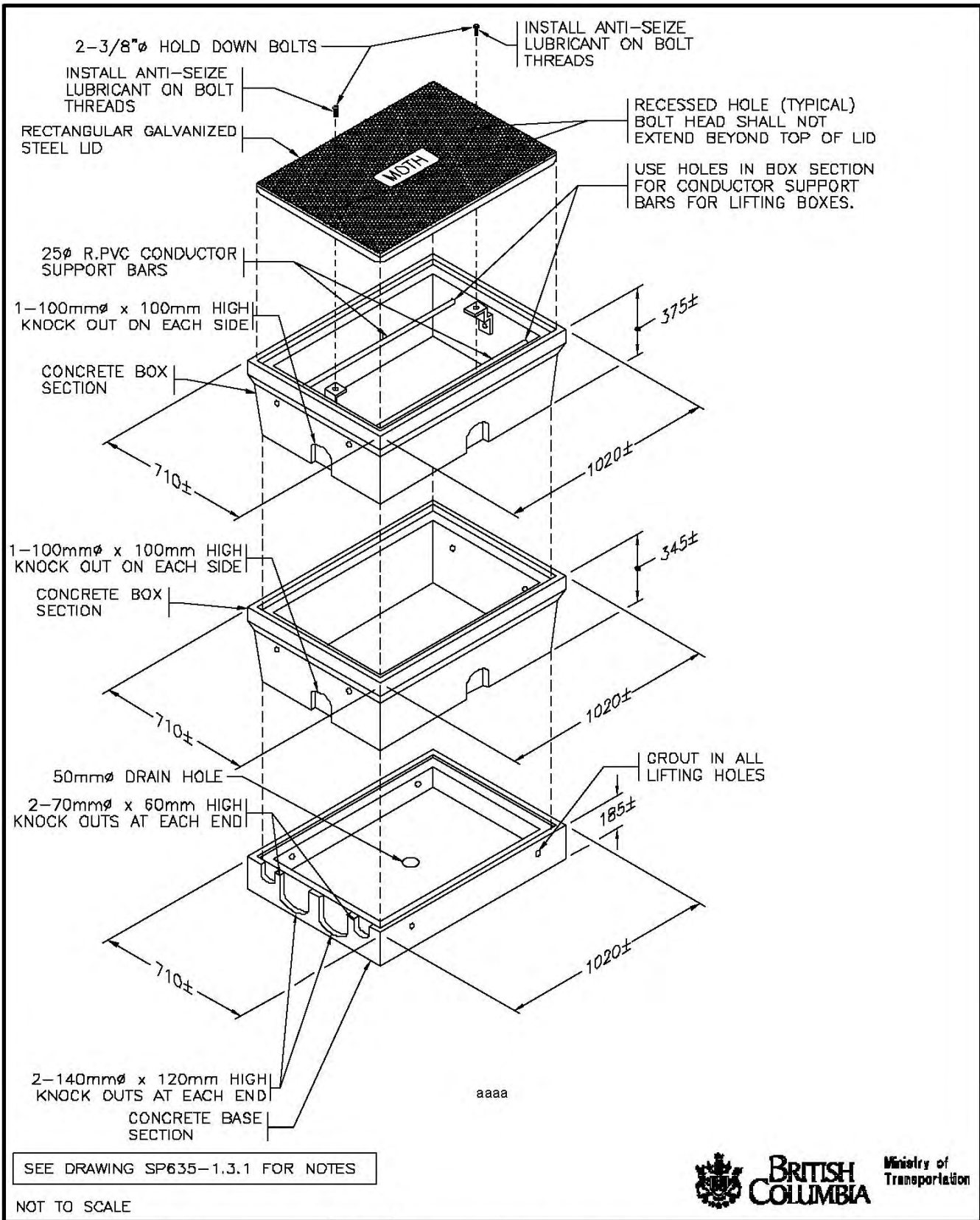

NOT TO SCALE



No.	Revision	Date
E	GENERAL REVISIONS	APR 05
D	KON KAST PRODUCT DELETED	OCT 03
C	A.E. CONCRETE DIMS. REVISED & ANTI-SEIZE LUBRICANT NOTED	NOV 98
B	LID HOLD DOWN & BOX SIZES REVISED	AUG 96
A	BOLTS & STEEL INSERTS ADDED	AUG 95

CONCRETE JUNCTION BOX DETAILS		DATE	APPROVED	SPECIFICATION DRAWING No.
		18/11/94	E.L. (Signature on File) Chief Highway Engineer	SP635-1.3.2

APPROXIMATE MASS
1320 kg

TOP OF VAULT SHALL BE FLUSH WITH FINISHED GRADE (SHIM COLLAR AS REQUIRED)

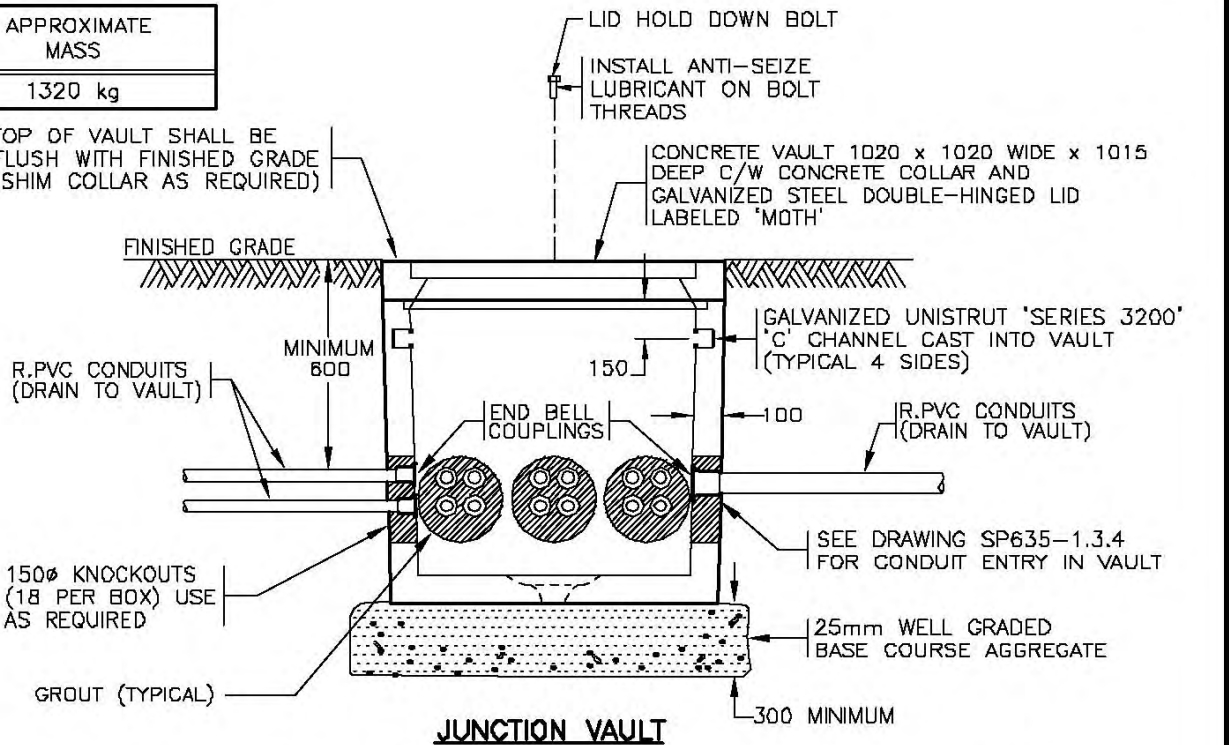

JUNCTION VAULT

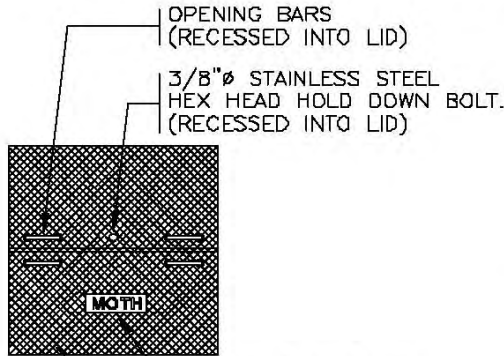

GALVANIZED STEEL CHECKERPLATE LID
 LABEL 'MOTH' WITH 100mm HIGH LETTERS

LID DETAIL

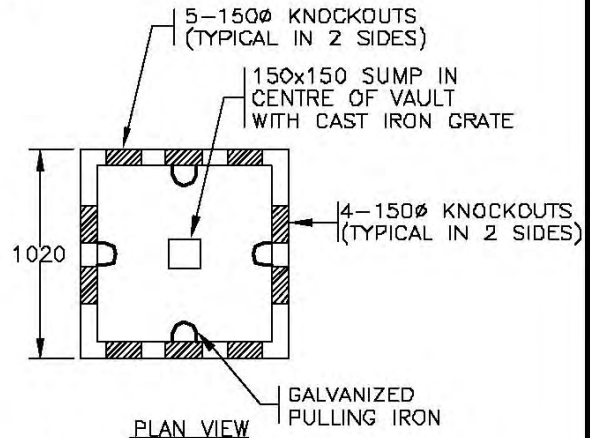

KNOCKOUT & SUMP LOCATIONS

NOTES

- SEE STANDARD SPECIFICATIONS & SPECIAL PROVISIONS FOR ADDITIONAL INFORMATION.
- VAULT SHALL BE 'A.E. CONCRETE PRE-CAST PRODUCTS LTD' TYPE, 'KON KAST PRODUCTS LTD.' OR APPROVED ALTERNATIVE.
- VAULT SHALL BE DESIGNED FOR H-20 STATIC LOADING.
- LIDS SHALL BE SUPPLIED GALVANIZED. aaaa
- VAULTS SHALL BE PRE-CAST CONCRETE WITH A MINIMUM COMPRESSIVE STRENGTH OF 35 MPa AT 28 DAYS.
- ALL DIMENSIONS ARE IN MILLIMETRES UNLESS OTHERWISE NOTED.

NOT TO SCALE



No.	Revision	Date
E		
D		
C	LID HOLD DOWN BOLT & ANTI-SEIZE LUBRICANT NOTED	NOV 98
B	NOTE 2 REVISED	AUG 95
A	GENERAL REVISIONS	AUG 94

SMALL CONCRETE VAULT DETAILS (1020 SQUARE X 1015 DEEP)		
Date	Approved	SPECIFICATION DRAWING No.
30/09/93	E.L. (Signature on File) Chief Highway Engineer	SP635-1.3.3

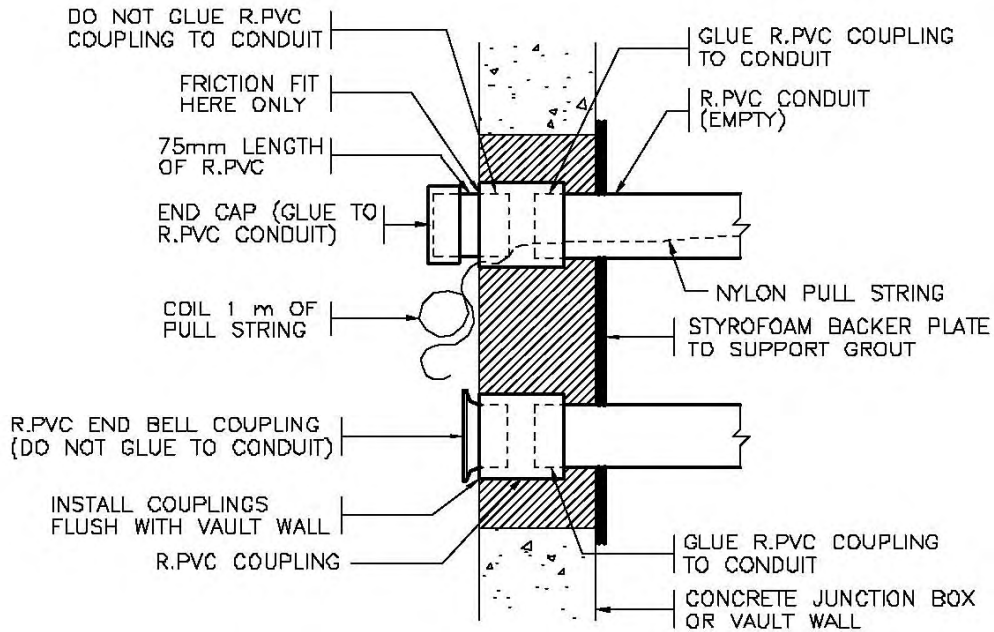

CONDUIT ENTRY TO VAULT OR CONCRETE JUNCTION BOX

NOTES

aaaa

1. SEE DRAWINGS SP635-1.3.1 TO -1.3.3 FOR NOTES AND ADDITIONAL DETAILS.
2. PULL STRING SHALL BE POLYPROPYLENE WITH A MINIMUM TENSILE STRENGTH OF 1.1kN. (BC HYDRO SPEC.)

NOT TO SCALE



No.	Revision	Date
F		
E		
D		
C	NOTES 1 & 2 ADDED	NOV 98
B	CONDUIT GLUING CLARIFIED	OCT 97
A	GENERAL REVISIONS	AUG 94

CONDUIT ENTRY INTO CONCRETE VAULT OR JUNCTION BOX		SPECIFICATION DRAWING No.
Date	Approved	SP635-1.3.4
30/09/93	E.L. (Signature on File) Chief Highway Engineer	

NOTES

1. SEE STANDARD SPECIFICATIONS & SPECIAL PROVISIONS FOR ADDITIONAL INFORMATION.
2. ALL DIMENSIONS ARE IN MILLIMETRES UNLESS OTHERWISE NOTED.
3. OFFSET SHOWN MAY VARY WHERE NOTED ON THE PLANS OR DIRECTED BY THE MINISTRY REPRESENTATIVE.
4. EXCAVATED MATERIAL SHALL BE USED AS BACKFILL WHERE IT CONSISTS OF CLEAN WELL GRADED GRANULAR SOIL HAVING A MAXIMUM FINES CONTENT OF 8% (SILT AND CLAY SIZE PARTICLES) AND A MAXIMUM AGGREGATE SIZE OF 100mm.
5. WHERE EXCAVATED MATERIAL IS UNACCEPTABLE OR EXTRA FILL IS REQUIRED AROUND POLE BASE & JUNCTION BOXES, USE 25mm WELL GRADED BASE COURSE AGGREGATE.
6. BACKFILL MATERIAL SHALL BE INSTALLED AND FULLY COMPACTED IN ACCORDANCE WITH SUBSECTION 635.07.01 FOR THE MINIMUM AREA ALL AROUND THE BASE AS SHOWN ABOVE.

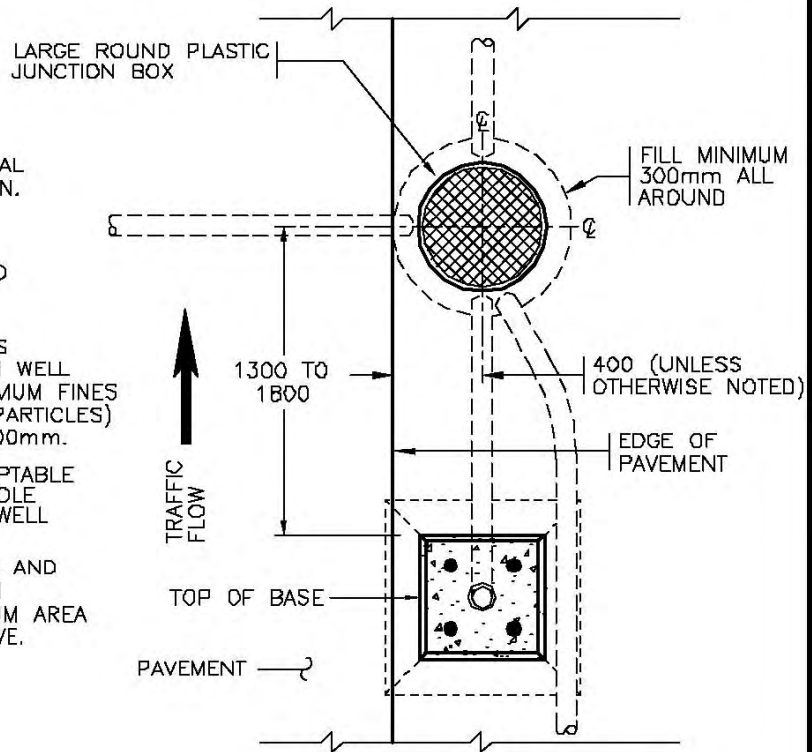

PLAN

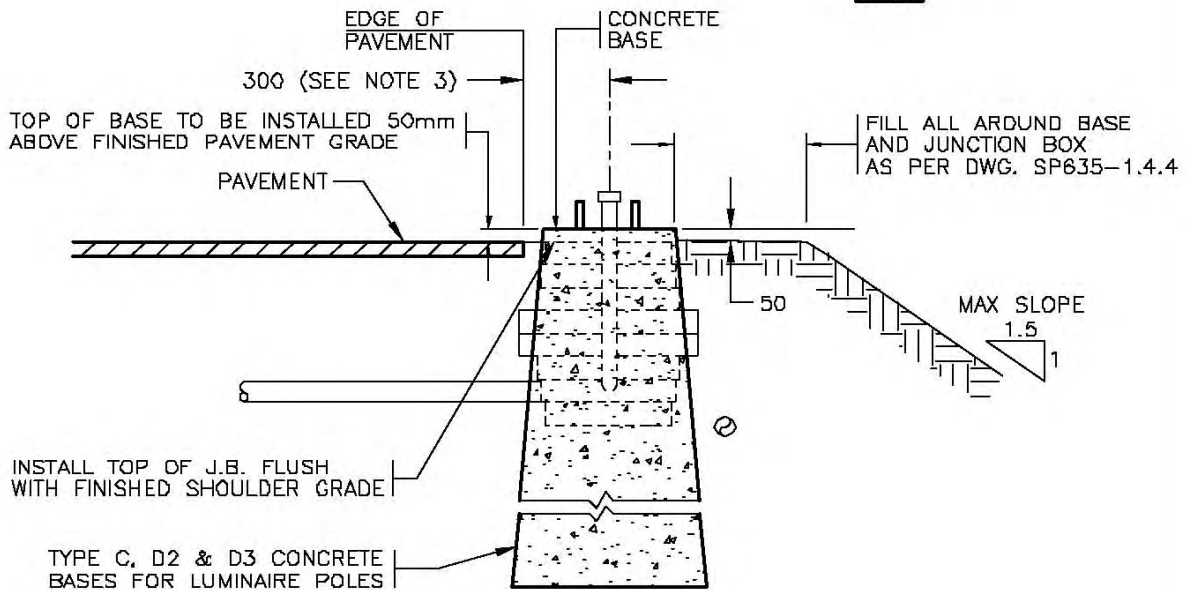

ELEVATION

NOT TO SCALE



No.	Revision	Date
F		
E		
D	NOTES 4, 5 & 6 REVISED	OCT 97
C	REVISED TO SUIT ONLY LUMINAIRE POLE BASES	AUG 96
B	BACKFILL REVISED	AUG 95
A	GENERAL REVISIONS	AUG 94

**LUMINAIRE POLE BASE AND JUNCTION BOX
INSTALLATION DETAIL FOR STANDARD ROADWAY**

Date: **30/09/93** Approved: **E.L. (Signature on File)**
Chief Highway Engineer

SPECIFICATION
DRAWING No.
SP635-1.4.1

NOTES

1. SEE STANDARD SPECIFICATIONS & SPECIAL PROVISIONS FOR ADDITIONAL INFORMATION.
2. ALL DIMENSIONS ARE IN MILLIMETRES UNLESS OTHERWISE NOTED.
3. OFFSET SHOWN MAY VARY WHERE NOTED ON THE PLANS OR DIRECTED BY THE MINISTRY REPRESENTATIVE.
4. EXCAVATED MATERIAL SHALL BE USED AS BACKFILL WHERE IT CONSISTS OF CLEAN WELL GRADED GRANULAR SOIL HAVING A MAXIMUM FINES CONTENT OF 8% (SILT AND CLAY SIZE PARTICLES) AND A MAXIMUM AGGREGATE SIZE OF 100mm.
5. WHERE EXCAVATED MATERIAL IS UNACCEPTABLE OR EXTRA FILL IS REQUIRED AROUND POLE BASE & JUNCTION BOXES, USE 25mm WELL GRADED BASE COURSE AGGREGATE.
6. BACKFILL MATERIAL SHALL BE INSTALLED AND FULLY COMPACTED IN ACCORDANCE WITH SUBSECTION 635.07.01 FOR THE MINIMUM AREA ALL AROUND THE BASE AS SHOWN ABOVE.

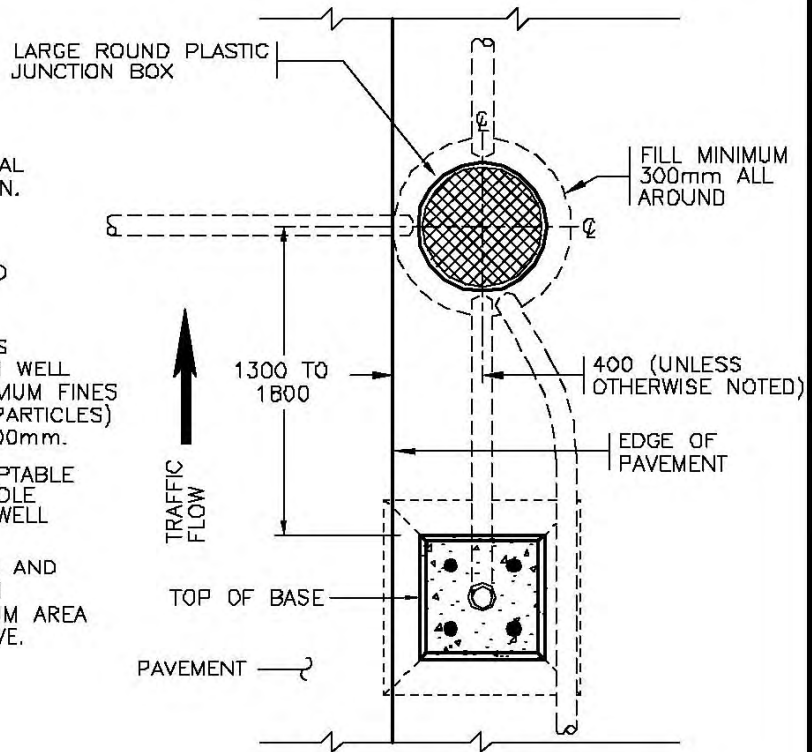

PLAN

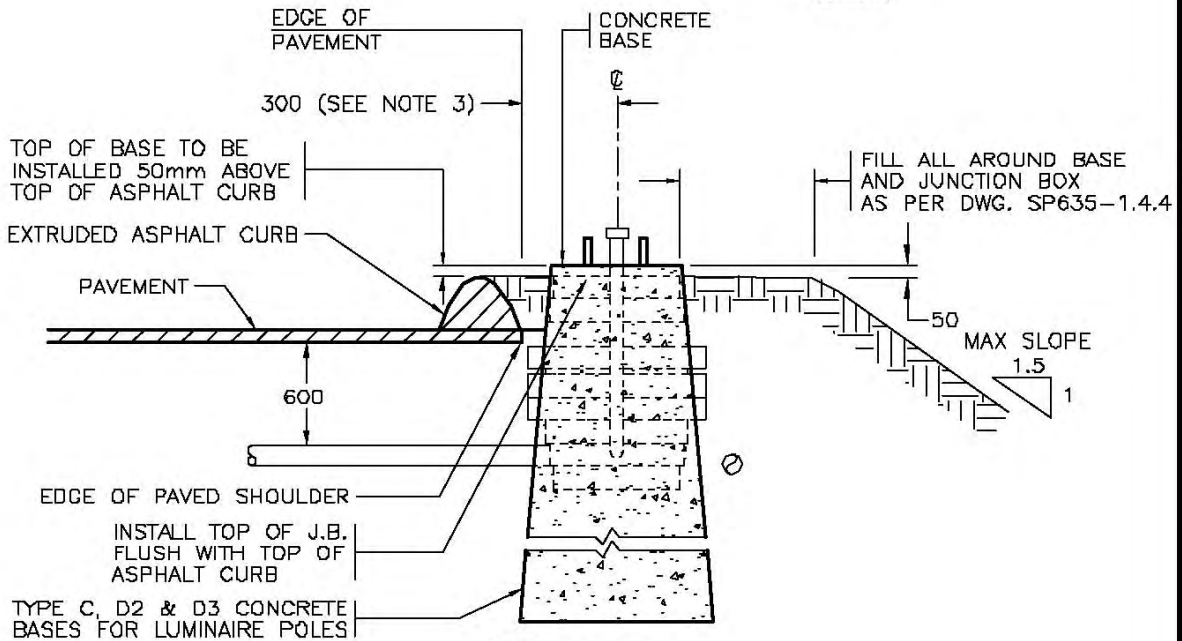

ELEVATION

NOT TO SCALE



No.	Revision	Date
F		
E		
D	NOTES 4, 5 & 6 REVISED	OCT 97
C	REVISED TO SUIT ONLY LUMINAIRE POLE BASES	AUG 96
B	BACKFILL REVISED	AUG 95
A	GENERAL REVISIONS	AUG 94

LUMINAIRE POLE BASE AND JUNCTION BOX INSTALLATION DETAIL FOR ASPHALT CURB

Date: **30/09/93** Approved: **E.L. (Signature on File)**
 Chief Highway Engineer

SPECIFICATION DRAWING No. **SP635-1.4.2**

NOTES

1. SEE STANDARD SPECIFICATIONS & SPECIAL PROVISIONS FOR ADDITIONAL INFORMATION.
2. ALL DIMENSIONS ARE IN MILLIMETRES UNLESS OTHERWISE NOTED.
3. OFFSET SHOWN MAY VARY WHERE NOTED ON THE PLANS OR DIRECTED BY THE MINISTRY REPRESENTATIVE.
4. EXCAVATED MATERIAL SHALL BE USED AS BACKFILL WHERE IT CONSISTS OF CLEAN WELL GRADED GRANULAR SOIL HAVING A MAXIMUM FINES CONTENT OF 8% (SILT AND CLAY SIZE PARTICLES) AND A MAXIMUM AGGREGATE SIZE OF 100mm.
5. WHERE EXCAVATED MATERIAL IS UNACCEPTABLE OR EXTRA FILL IS REQUIRED AROUND POLE BASE & JUNCTION BOXES, USE 25mm WELL GRADED BASE COURSE AGGREGATE.
6. BACKFILL MATERIAL SHALL BE INSTALLED AND FULLY COMPACTED IN ACCORDANCE WITH SUBSECTION 635.07.01 FOR THE MINIMUM AREA ALL AROUND THE BASE AS SHOWN ABOVE.

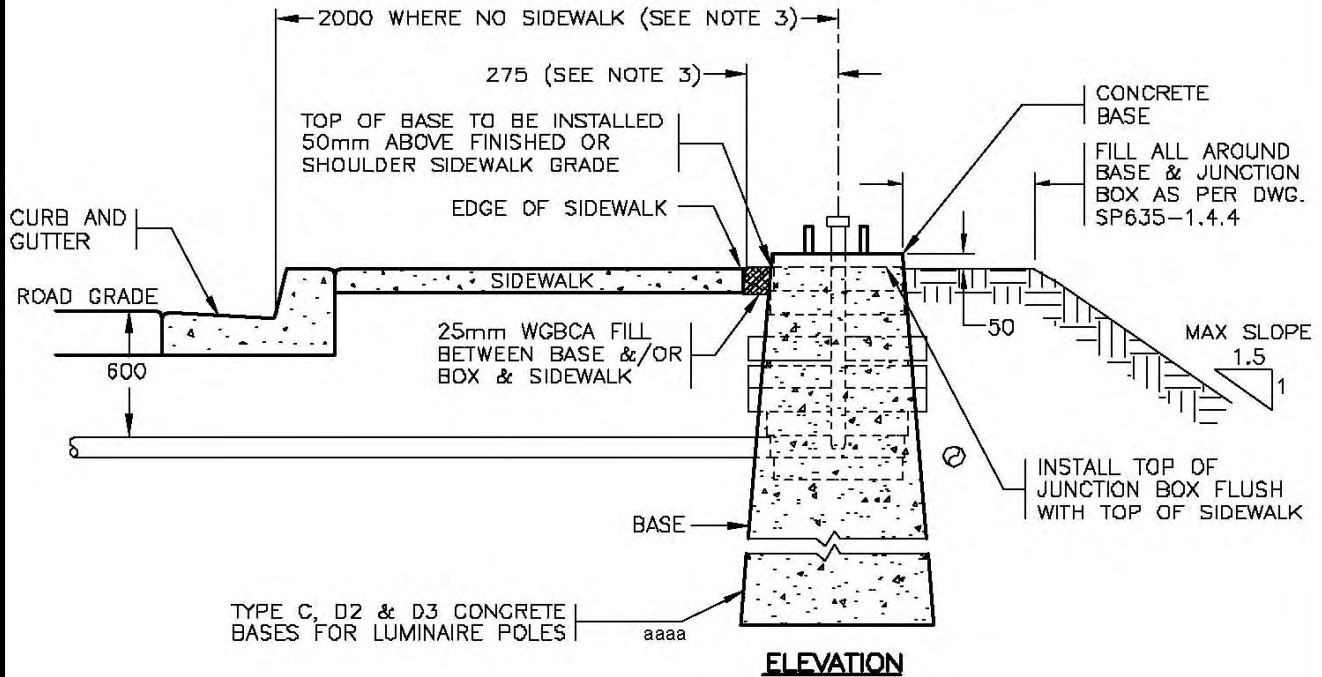
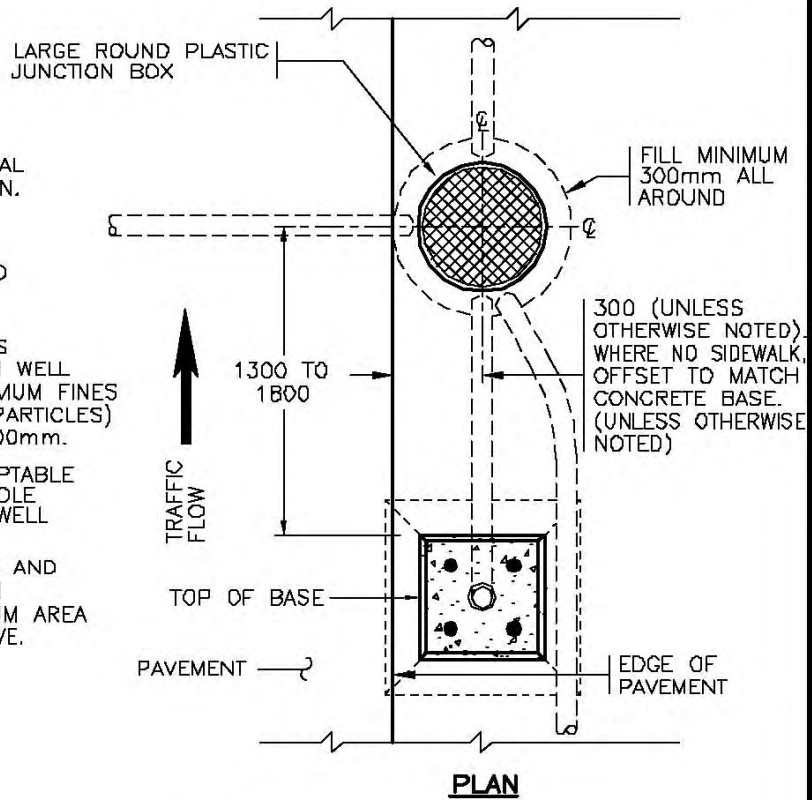

NOT TO SCALE



No.	Revision	Date
F		
E		
D	NOTES 4, 5 & 6 REVISED	OCT 97
C	REVISED TO SUIT ONLY LUMINAIRE POLE BASES	AUG 96
B	BACKFILL REVISED	AUG 95
A	GENERAL REVISIONS	AUG 94

LUMINAIRE POLE BASE AND JUNCTION BOX INSTALLATION DETAIL FOR SIDEWALK

Date: **30/09/93** Approved: **E.L. (Signature on File)**
Chief Highway Engineer

SPECIFICATION DRAWING No. **SP635-1.4.3**

BASE TYPES	A MIN. FILL
TYPES A, B AND C CONCRETE BASES	300
TYPES D2, D3, E2 AND E3 CONCRETE BASES	3600
TYPES F2, F3, L2, L3, S2 AND S3 CONCRETE BASES	4600
TYPE M2 CONCRETE BASES	5400
TYPE H2 CONCRETE BASES	6400

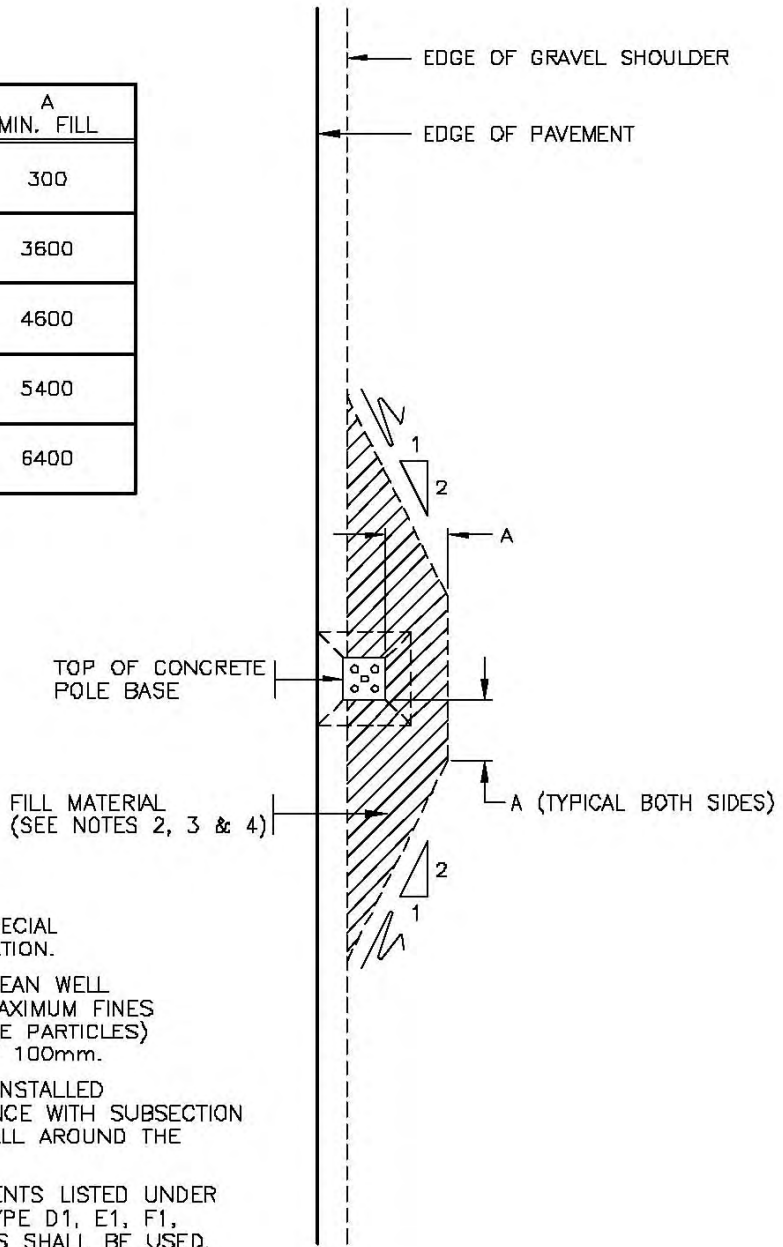

NOTES

- SEE STANDARD SPECIFICATIONS & SPECIAL PROVISIONS FOR ADDITIONAL INFORMATION.
- FILL MATERIAL SHALL CONSIST OF CLEAN WELL GRADED GRANULAR SOIL HAVING A MAXIMUM FINES CONTENT OF 8% (SILT AND CLAY SIZE PARTICLES) AND A MAXIMUM AGGREGATE SIZE OF 100mm.
- FILL MATERIAL SHALL BE SUPPLIED, INSTALLED AND FULLY COMPACTED IN ACCORDANCE WITH SUBSECTION 635.07.01 FOR THE MINIMUM AREA ALL AROUND THE BASE AS SHOWN ABOVE.
- WHERE THE MINIMUM FILL REQUIREMENTS LISTED UNDER NOTES 2 AND 3 CANNOT BE MET, TYPE D1, E1, F1, L1, S1, M1 OR H1 SPREAD FOOTINGS SHALL BE USED.
- TYPICAL OFFSETS OF TYPE C, D2 & D3 LUMINAIRE POLE BASES ARE SHOWN ON DRAWINGS SP635-1.4.1 TO 1.4.3 OFFSETS OF TYPE A, B, E2, E3, F2, F3, L2, L3, S2, S3, M2 & H2 SIGNAL & SIGN POLE BASES SHALL BE NOTED ON PLANS OR AS DIRECTED BY THE MINISTRY ELECTRICAL REPRESENTATIVE.

NOT TO SCALE



No.	Revision	Date	BACKFILL REQUIREMENTS FOR TYPE A, B, C, D2, D3, E2, E3, F2, F3, L2, L3, S2, S3, M2 & H2 CONCRETE BASES	
E			Date	Approved
D			15/11/95	M.C. (Signature on File)
C			SPECIFICATION DRAWING No. SP635-1.4.4	
B	TYPE S BASES ADDED & REFERENCE CHANGED TO "MINISTRY ELECTRICAL REPRESENTATIVE"	OCT 03	Chief Highway Engineer	
A	NOTE 5 ADDED	AUG 96		

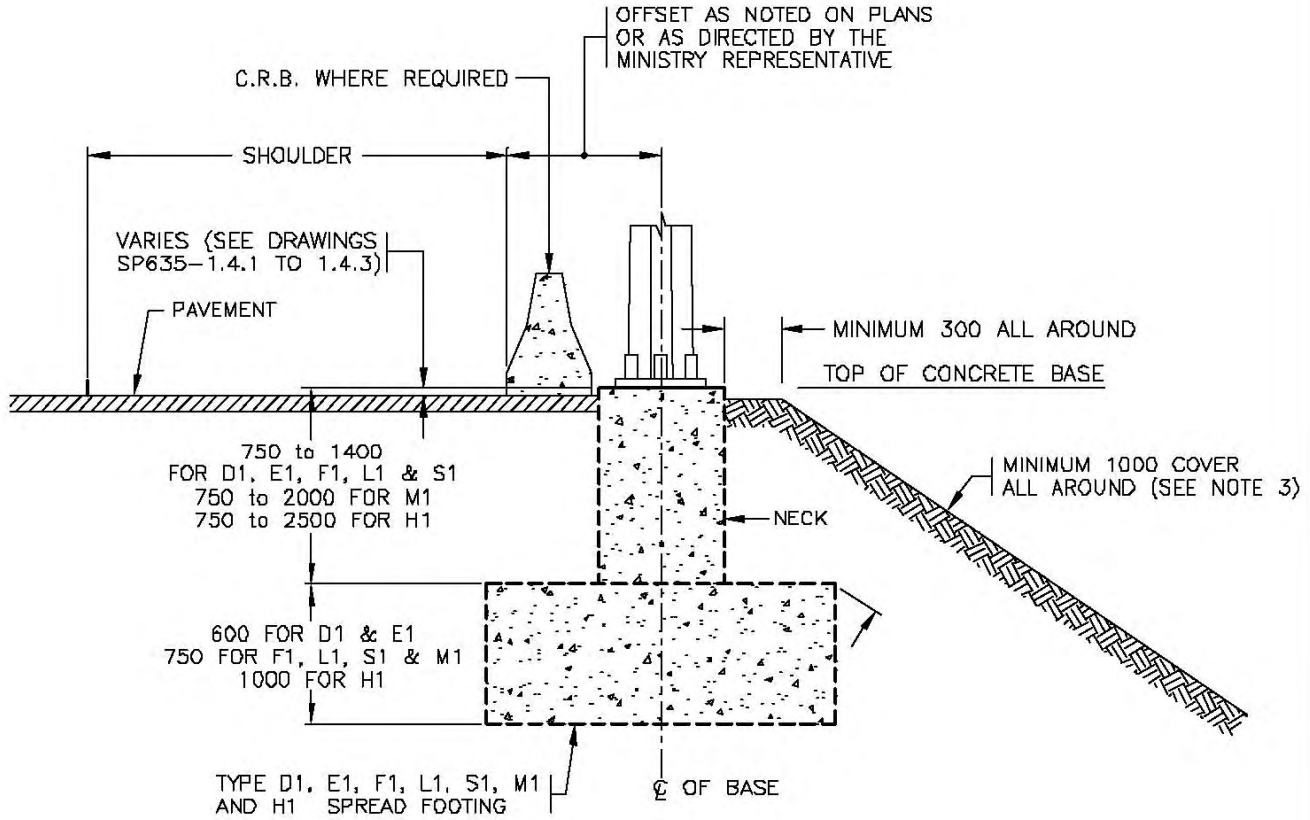

ELEVATION

NOTES

1. SEE STANDARD SPECIFICATIONS & SPECIAL PROVISIONS FOR ADDITIONAL INFORMATION.
2. ALL DIMENSIONS ARE IN MILLIMETRES UNLESS OTHERWISE NOTED.
3. VARY NECK HEIGHT UP TO THE MAXIMUMS SHOWN TO PROVIDE COVER AROUND SPREAD FOOTING. aaaa
4. BACKFILL MATERIAL SHALL BE INSTALLED & FULLY COMPACTED IN ACCORDANCE WITH SUBSECTION 635.07.01 TO PROVIDE THE MINIMUM COVER OVER THE SPREAD FOOTING.



NOT TO SCALE

No.	Revision	Date	BACKFILL REQUIREMENTS FOR TYPE D1, E1, F1, L1, S1, M1 & H1 CONCRETE SPREAD FOOTINGS	
F			Date	Approved
E			15/11/95	M.C. (Signature on File)
D			SPECIFICATION DRAWING No.	
C			SP635-1.4.5	
B	TYPE S1 BASES ADDED	OCT 03	Chief Highway Engineer	
A	MAX. SLOPE DELETED & NECK HEIGHT REV'D	AUG 96		

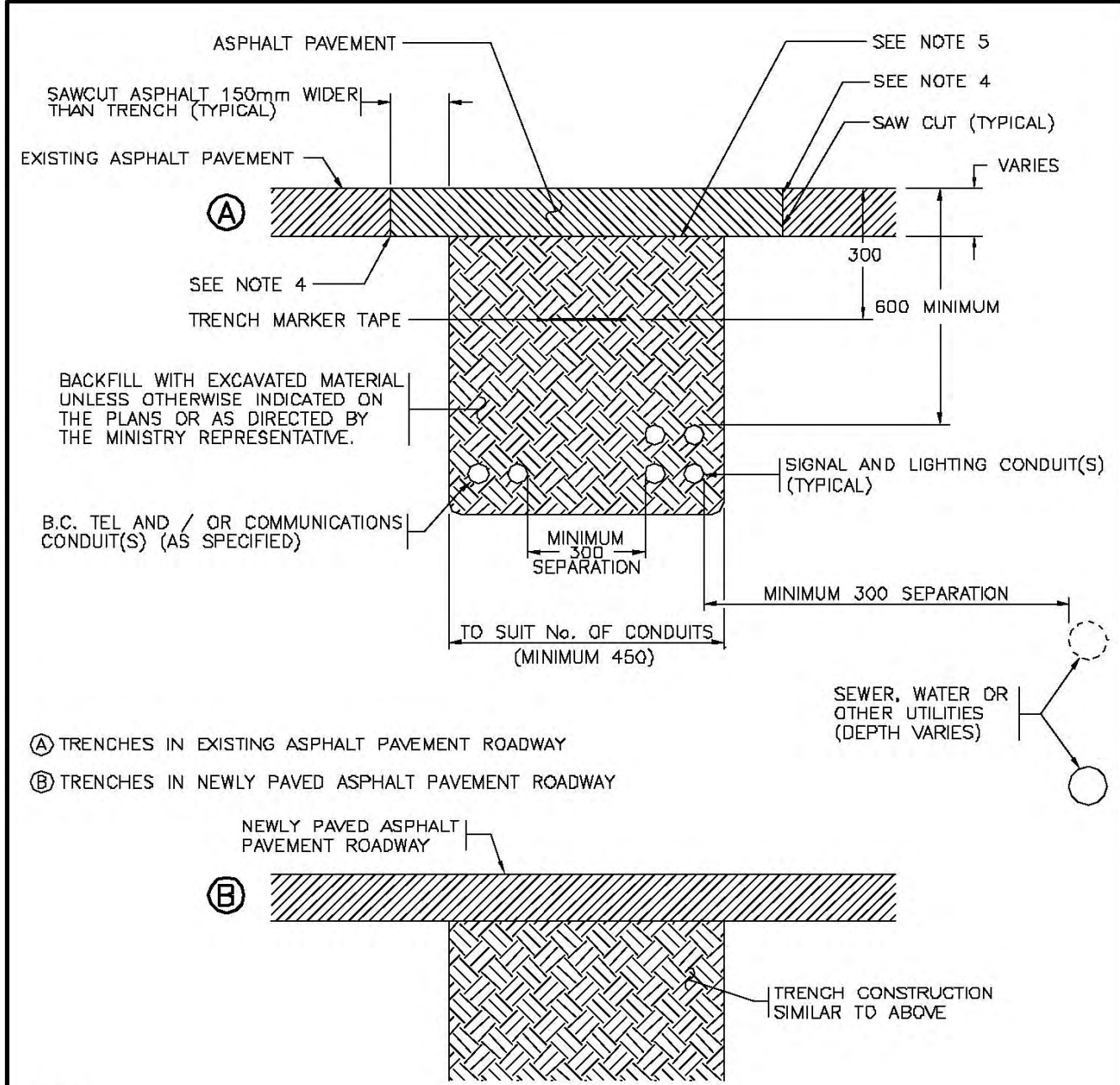

- Ⓐ TRENCHES IN EXISTING ASPHALT PAVEMENT ROADWAY
- Ⓑ TRENCHES IN NEWLY PAVED ASPHALT PAVEMENT ROADWAY

NOTES

1. SEE STANDARD SPECIFICATIONS & SPECIAL PROVISIONS FOR ADDITIONAL INFORMATION.
2. WHERE MINIMUM CLEARANCES FROM UTILITIES CAN NOT BE MAINTAINED, NOTIFY THE MINISTRY REPRESENTATIVE.
3. ALL DIMENSIONS ARE IN MILLIMETRES UNLESS OTHERWISE NOTED. aaaa
4. APPLY 0.25 L/m² OF RM-20 SEALANT TO THE EDGE OF EXISTING ASPHALT.
5. APPLY 1.5 L/m² OF RM-20 SEALANT TO THE GRAVEL BASE.



NOT TO SCALE

No.	Revision	Date	CONDUIT INSTALLATION IN PAVED AREAS	
F			Date	Approved
E			30/09/93	E.L. (Signature on File)
D			Chief Highway Engineer	
C			SPECIFICATION DRAWING No.	
B			SP635-1.5.1	
A	GENERAL REVISIONS	AUG 94		

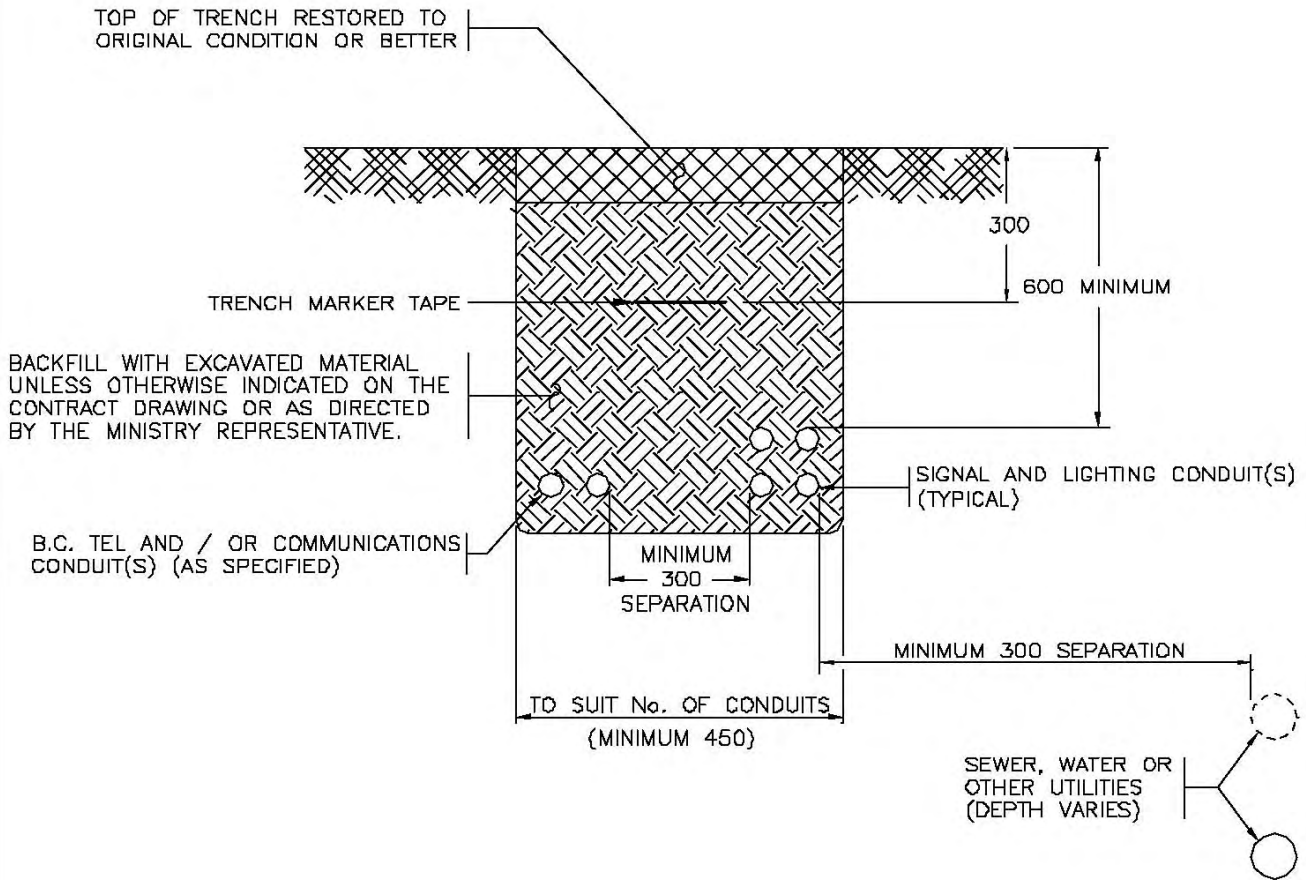

NOTES

1. SEE STANDARD SPECIFICATIONS & SPECIAL PROVISIONS FOR ADDITIONAL INFORMATION.
2. WHERE MINIMUM CLEARANCES FROM UTILITIES CAN^{aaaa} NOT BE MAINTAINED, NOTIFY THE MINISTRY REPRESENTATIVE.
3. ALL DIMENSIONS ARE IN MILLIMETRES UNLESS OTHERWISE NOTED.

NOT TO SCALE



No.	Revision	Date	CONDUIT INSTALLATION IN NON-PAVED AREAS	
F			Date	Approved
E			30/09/93	E.L. (Signature on File)
D				Chief Highway Engineer
C			SPECIFICATION DRAWING No.	
B			SP635-1.5.2	
A	GENERAL REVISIONS	AUG 94		

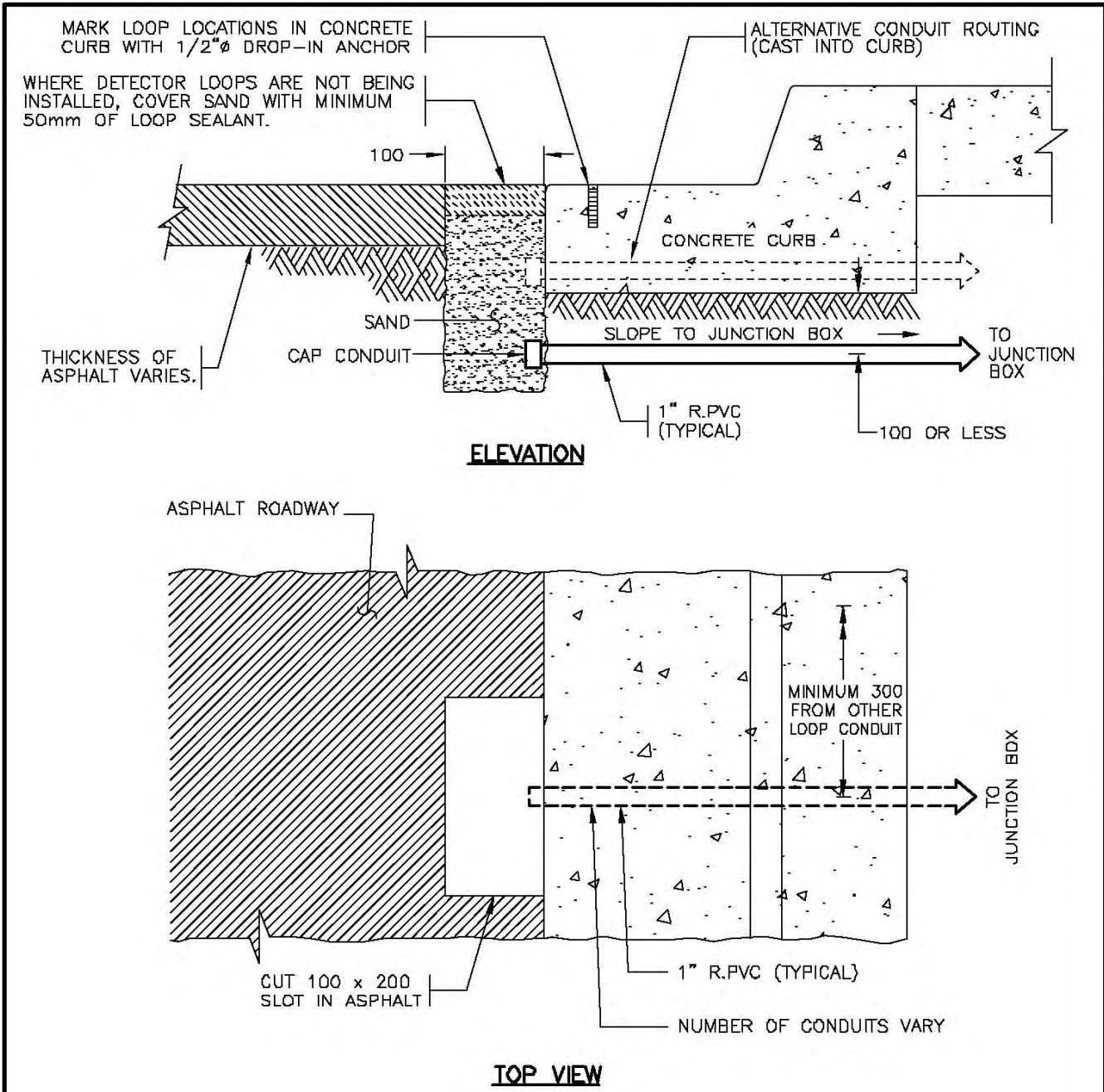

NOTES

1. SEE STANDARD SPECIFICATIONS & SPECIAL PROVISIONS FOR ADDITIONAL INFORMATION.
2. ALL DIMENSIONS ARE IN MILLIMETRES UNLESS OTHERWISE NOTED. aaaa
3. LOCATE LOOP CONDUIT IN ASPHALT TO SUIT LOOP LOCATIONS AND TO MINIMIZE THE LENGTH OF HOME RUN SLOTS IN THE ASPHALT.

NOT TO SCALE



No.	Revision	Date	LOOP CONDUIT INSTALLATION DETAILS AT CONCRETE CURB	
F				
E				
D				
C				
B	CONDUIT SLOT REVISED	AUG 95	Date	Approved
A	GENERAL REVISIONS	AUG 94	30/09/93	E.L. (Signature on File) Chief Highway Engineer
			SPECIFICATION DRAWING No. SP635-1.6.1	

CUT LOOP SLOT 300mm FROM EDGE OF ASPHALT OR WHERE CONCRETE BARRIERS ARE PROPOSED OR EXISTING CUT SLOT 150mm IN FRONT OF BARRIER

WHERE DETECTOR LOOPS ARE NOT BEING INSTALLED, COVER SAND WITH MINIMUM 50mm OF LOOP SEALANT.

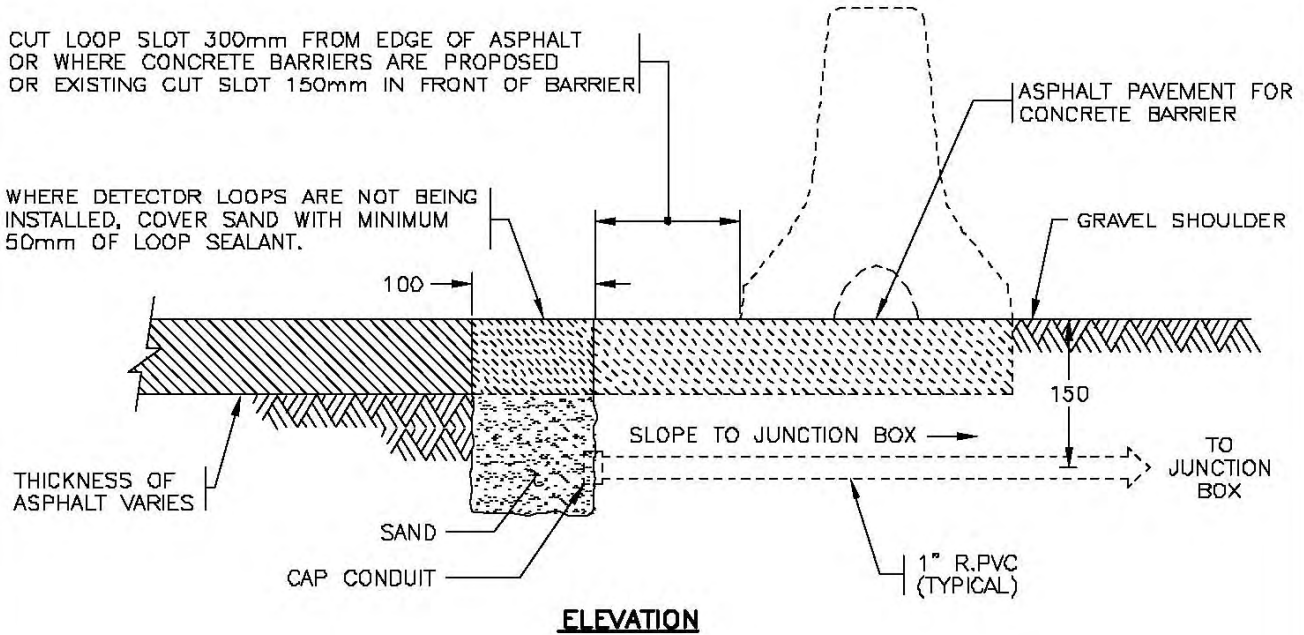

ELEVATION

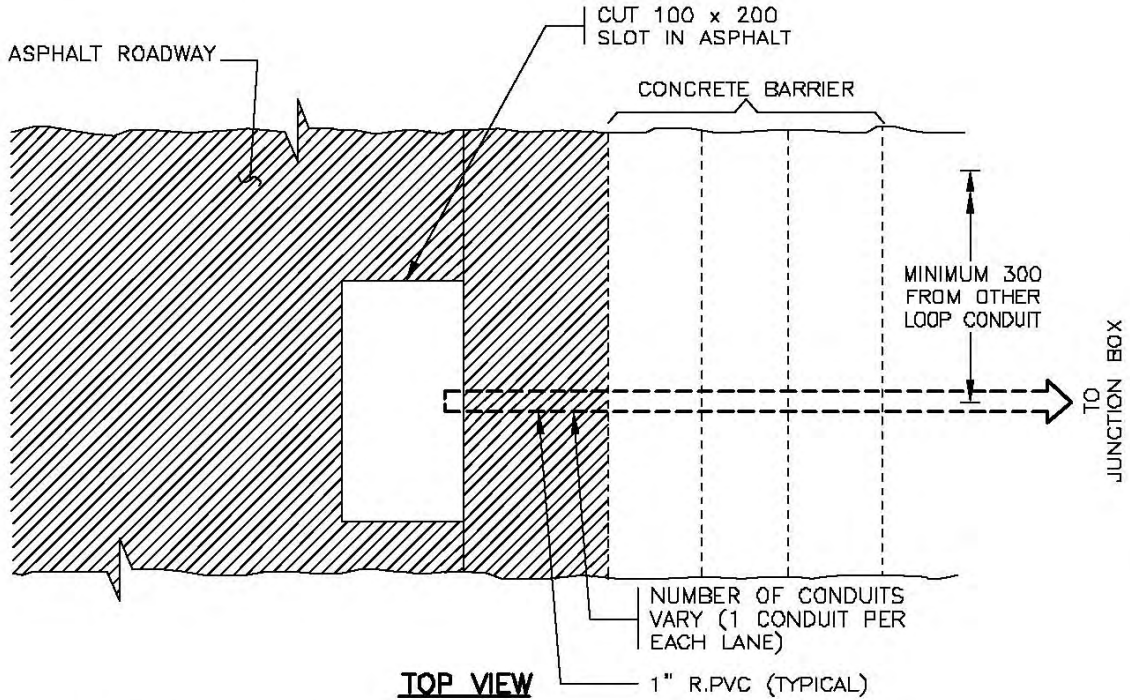

TOP VIEW

NOTES

1. SEE STANDARD SPECIFICATIONS & SPECIAL PROVISIONS FOR ADDITIONAL INFORMATION.
2. ALL DIMENSIONS ARE IN MILLIMETRES UNLESS OTHERWISE NOTED.
3. LOCATE LOOP CONDUIT IN ASPHALT TO SUIT LOOP LOCATIONS AND TO MINIMIZE THE LENGTH OF HOME RUN SLOTS IN THE ASPHALT.

aaaa

NOT TO SCALE



No.	Revision	Date
F		
E		
D		
C		
B	CONCRETE BARRIER SHOWN	NOV 98
A	CONDUIT SLOT REVISED	AUG 95

LOOP CONDUIT INSTALLATION DETAILS IN GRAVEL SHOULDER

Date: **18/11/94**
 Approved: **E.L. (Signature on File)**
 Chief Highway Engineer

SPECIFICATION DRAWING No. **SP635-1.6.2**

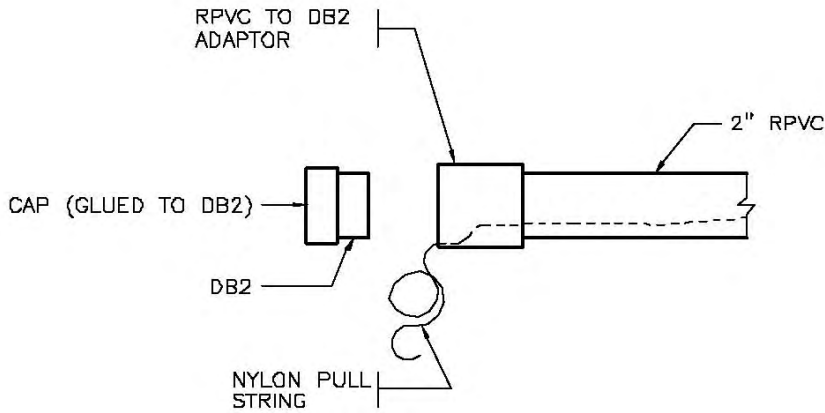

CONDUIT ADAPTOR AND PLUG DETAIL

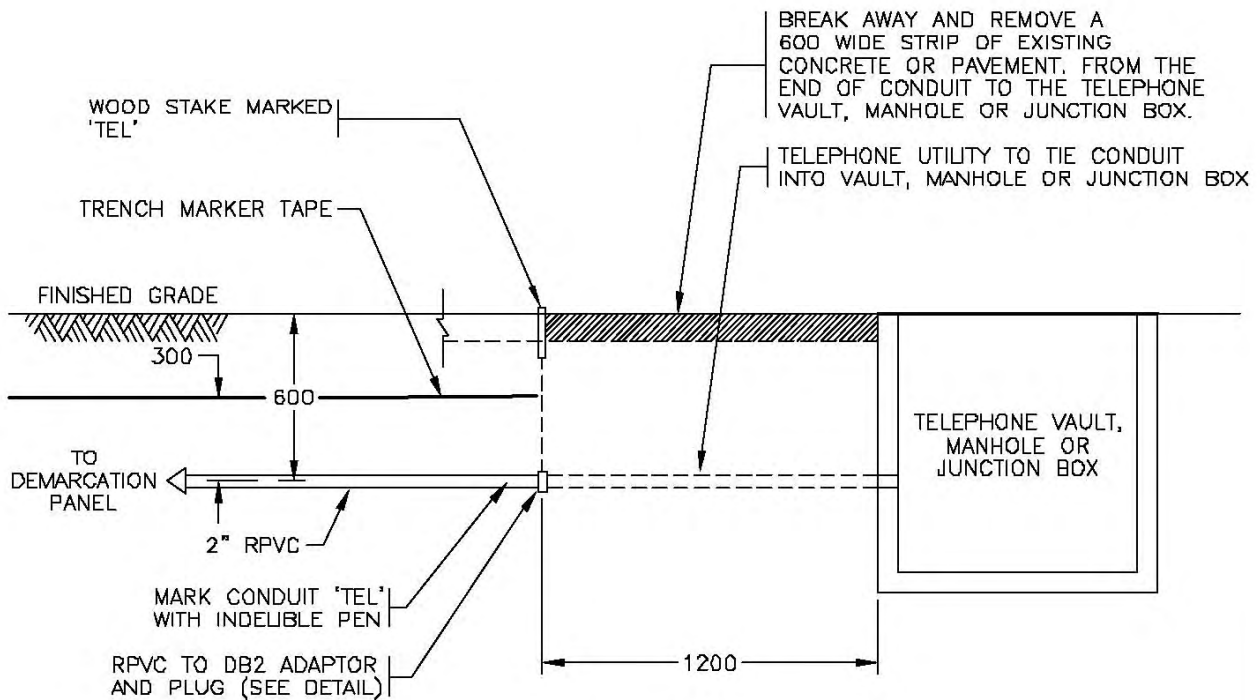

ELEVATION

NOTES

1. SEE STANDARD SPECIFICATIONS AND SPECIAL PROVISIONS FOR ADDITIONAL INFORMATION.
2. ALL DIMENSIONS ARE IN MILLIMETRES UNLESS OTHERWISE NOTED.

aaaa

NOT TO SCALE



No.	Revision	Date
F		
E		
D		
C		
B		
A		

CONDUIT TIE-IN TO TELEPHONE VAULT, MANHOLE OR JUNCTION BOX

Date **17/11/94** Approved **E.L. (Signature on File)**
Chief Highway Engineer

SPECIFICATION DRAWING No. **SP635-1.7.1**

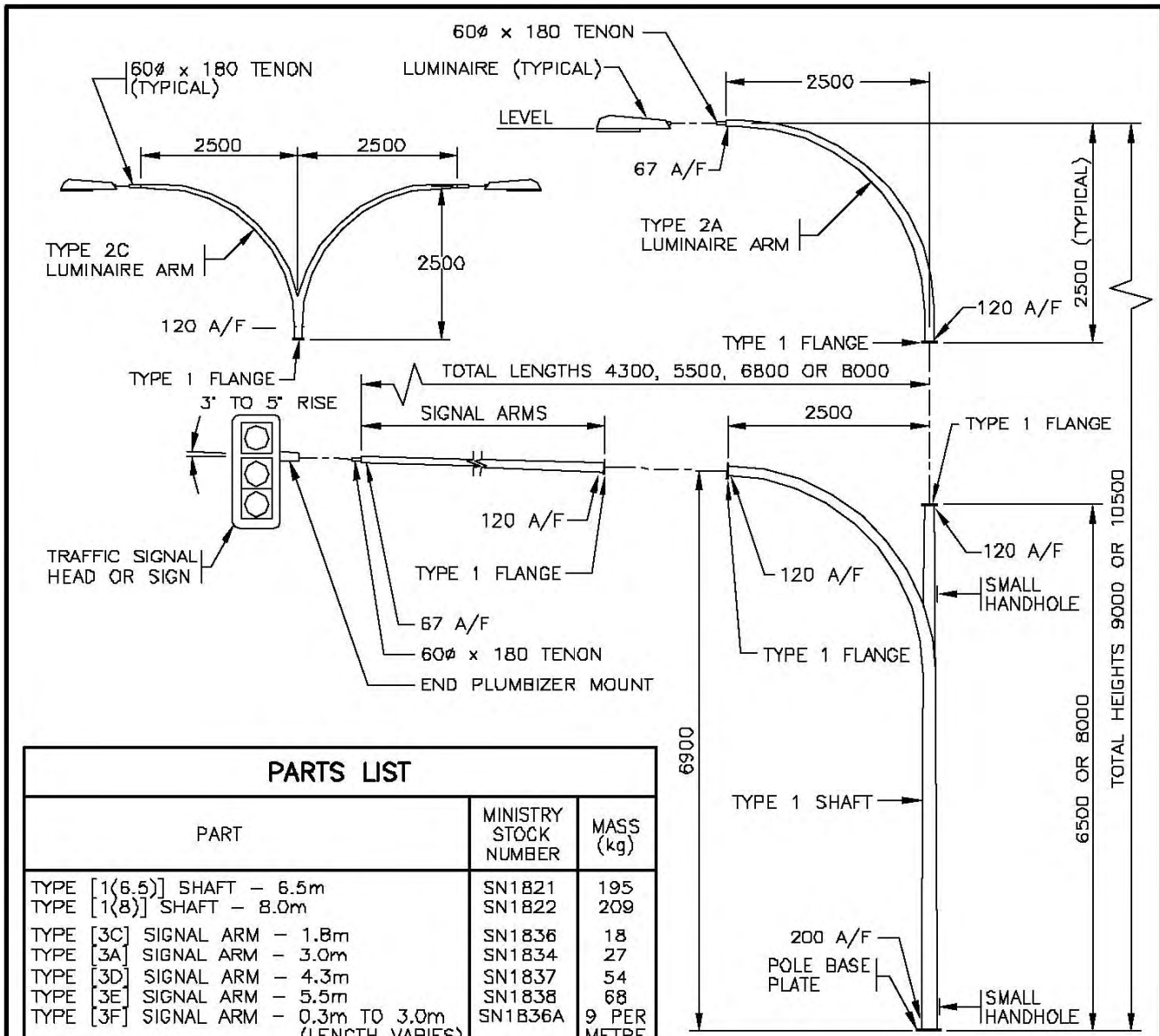

PARTS LIST		
PART	MINISTRY STOCK NUMBER	MASS (kg)
TYPE [1{6.5}] SHAFT - 6.5m	SN1821	195
TYPE [1{8}] SHAFT - 8.0m	SN1822	209
TYPE [3C] SIGNAL ARM - 1.8m	SN1836	18
TYPE [3A] SIGNAL ARM - 3.0m	SN1834	27
TYPE [3D] SIGNAL ARM - 4.3m	SN1837	54
TYPE [3E] SIGNAL ARM - 5.5m	SN1838	68
TYPE [3F] SIGNAL ARM - 0.3m TO 3.0m (LENGTH VARIES)	SN1836A	9 PER METRE
TYPE [2A] LUMINAIRE ARM	SN1832	35
TYPE [2C] LUMINAIRE ARM	SN1833	65
POST TOP TENON [PTT]	SN1831	5
TYPE 1 FLANGE COVER PLATE [1FCP]	SN1367	1.5

* [] I.D. LABEL ON POLE

NOTES

- SEE STANDARD SPECIFICATIONS & SPECIAL PROVISIONS FOR ADDITIONAL INFORMATION.
- SEE DRAWING SP635-2.1.2 FOR TYPE 1 SHAFT, BOLT KITS AND POLE ASSEMBLY DETAILS.
- ALL DIMENSIONS ARE IN MILLIMETRES UNLESS OTHERWISE NOTED.

NOT TO SCALE

ELEVATION

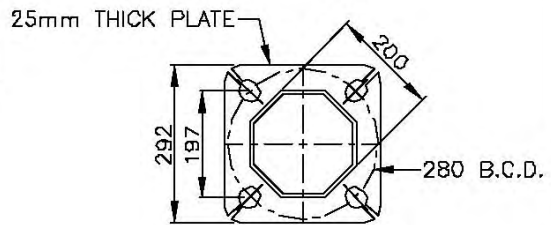

POLE BASE PLATE



No.	Revision	Date
F		
E		
D	SIGNAL HEAD MOUNTING REVISED	OCT 03
C	3F ARM ADDED	AUG 96
B	SIGNAL HEAD REVISED	AUG 95
A	GENERAL REVISIONS	AUG 94

TYPE 1 SHAFT INSTALLATION DETAILS (SIGNAL POLE)		
Date	Approved	SPECIFICATION DRAWING No.
30/09/93	E.L. (Signature on File) Chief Highway Engineer	SP635-2.1.1

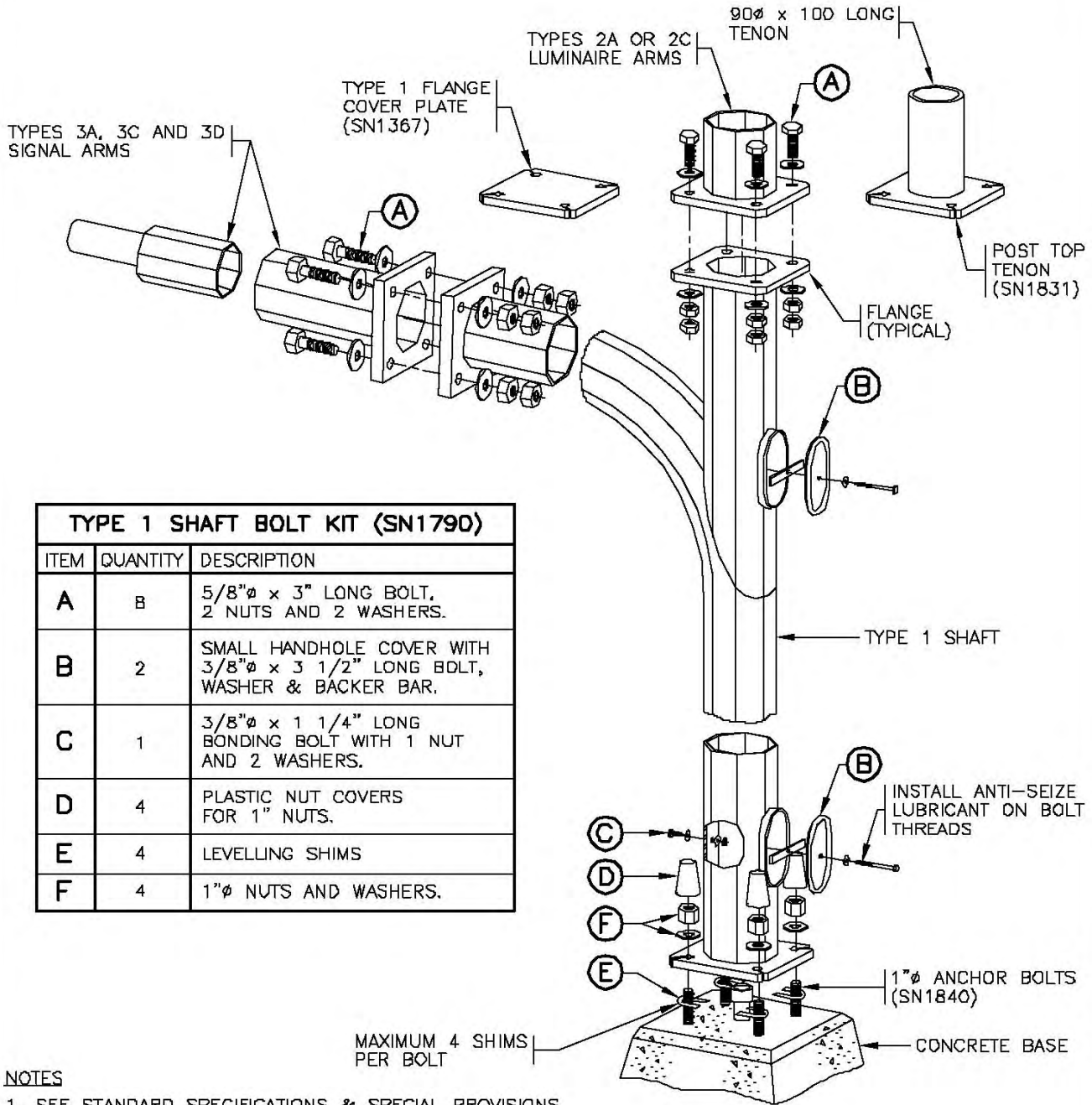

TYPE 1 SHAFT BOLT KIT (SN1790)		
ITEM	QUANTITY	DESCRIPTION
A	8	5/8"φ × 3" LONG BOLT, 2 NUTS AND 2 WASHERS.
B	2	SMALL HANDHOLE COVER WITH 3/8"φ × 3 1/2" LONG BOLT, WASHER & BACKER BAR.
C	1	3/8"φ × 1 1/4" LONG BONDING BOLT WITH 1 NUT AND 2 WASHERS.
D	4	PLASTIC NUT COVERS FOR 1" NUTS.
E	4	LEVELLING SHIMS
F	4	1"φ NUTS AND WASHERS.

NOTES

1. SEE STANDARD SPECIFICATIONS & SPECIAL PROVISIONS FOR ADDITIONAL INFORMATION.
2. POLE SHAFT SHALL BE INSTALLED PLUMB.
3. ALL SHAFTS, ARMS AND EXTENSIONS SHALL BE SUPPLIED WITH A GALVANIZED FINISH. aaaa
4. APPLY GREASE TO ANCHOR BOLT THREADS.
5. TOUCH UP ANY SCRATCHES IN GALVANIZED SURFACES WITH COLD GALVANIZING COMPOUND.

NOT TO SCALE

POLE ASSEMBLY DETAIL



No.	Revision	Date
E		
D		
C	ANTI-SEIZING LUBRICANT NOTED ON HANDHOLE BOLT	NOV 98
B	HANDHOLE BOLT LENGTH REVISED	AUG 96
A	GENERAL REVISIONS	AUG 94

TYPE 1 SHAFT INSTALLATION DETAILS (SIGNAL POLE)		
Date	Approved	SPECIFICATION DRAWING No.
30/09/93	E.L. (Signature on File) Chief Highway Engineer	SP635-2.1.2

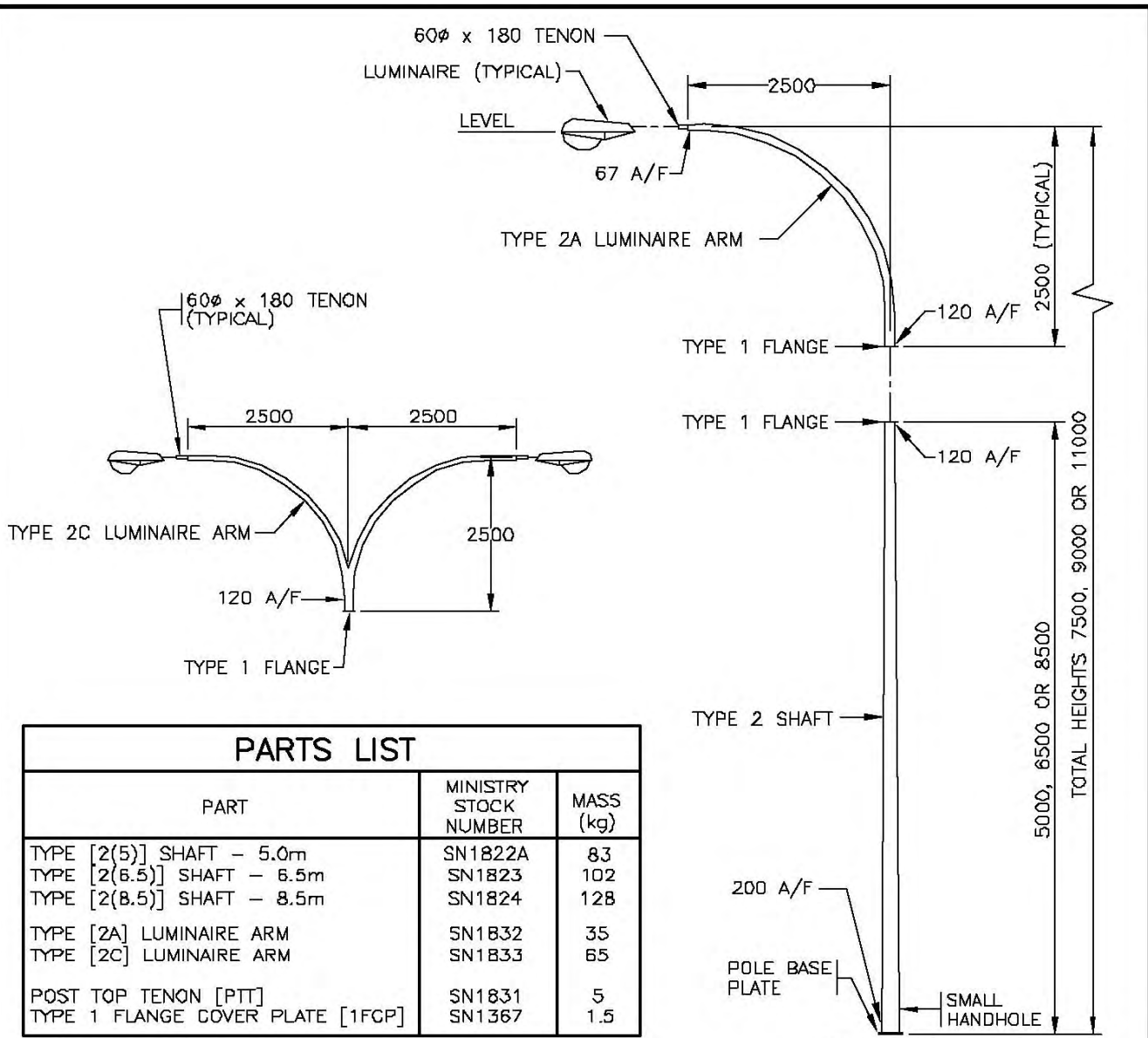

PARTS LIST

PART	MINISTRY STOCK NUMBER	MASS (kg)
TYPE [2(5)] SHAFT - 5.0m	SN1822A	83
TYPE [2(6.5)] SHAFT - 6.5m	SN1823	102
TYPE [2(8.5)] SHAFT - 8.5m	SN1824	128
TYPE [2A] LUMINAIRE ARM	SN1832	35
TYPE [2C] LUMINAIRE ARM	SN1833	65
POST TOP TENON [PTT]	SN1831	5
TYPE 1 FLANGE COVER PLATE [1FCP]	SN1367	1.5

* [] I.D. LABEL ON POLE

ELEVATION

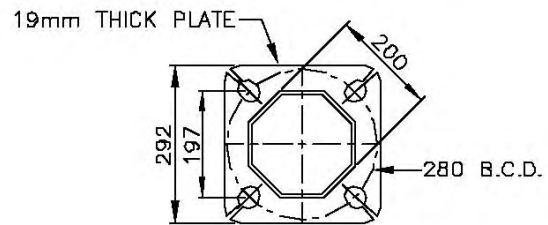

POLE BASE PLATE

NOTES

- SEE STANDARD SPECIFICATIONS & SPECIAL PROVISIONS FOR ADDITIONAL INFORMATION.
- SEE DRAWING SP635-2.1.4 FOR TYPE 2 SHAFT, BOLT KITS AND POLE ASSEMBLY DETAILS. aaaa
- ALL DIMENSIONS ARE IN MILLIMETRES UNLESS OTHERWISE NOTED.

NOT TO SCALE



No.	Revision	Date
F		
E		
D		
C		
B		
A	GENERAL REVISIONS	AUG 94

**TYPE 2 SHAFT INSTALLATION DETAILS
(7.5 m, 9.0 m AND 11.0 m LUMINAIRE POLES)**

Date **30/09/93** Approved **E.L. (Signature on File)**
Chief Highway Engineer

SPECIFICATION DRAWING No. **SP635-2.1.3**

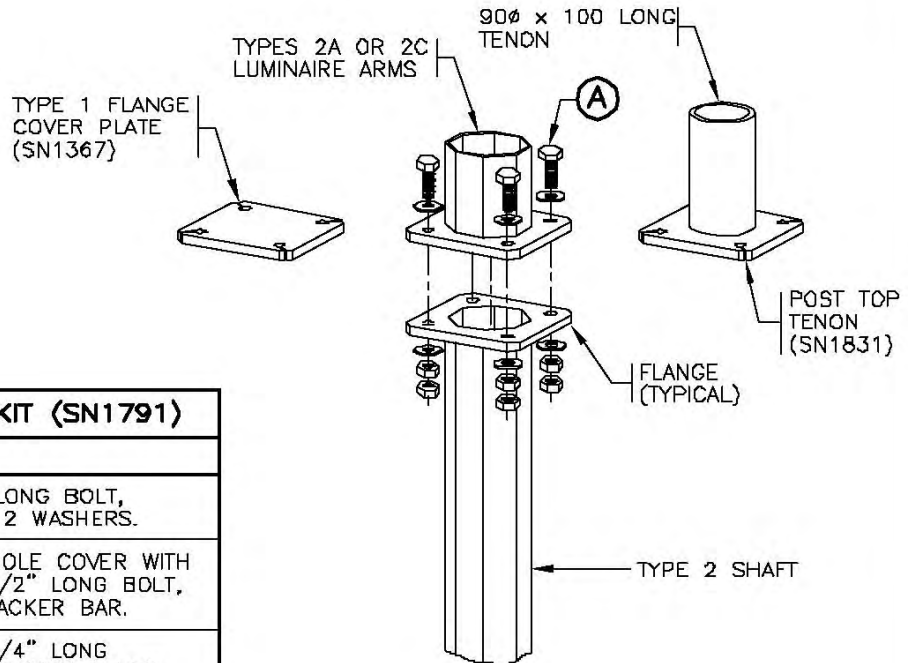

TYPE 2 SHAFT BOLT KIT (SN1791)		
ITEM	QUANTITY	DESCRIPTION
A	4	5/8"φ × 3" LONG BOLT, 2 NUTS AND 2 WASHERS.
B	1	SMALL HANDHOLE COVER WITH 3/8"φ × 3 1/2" LONG BOLT, WASHER & BACKER BAR.
C	1	3/8"φ × 1 1/4" LONG BONDING BOLT WITH 1 NUT AND 2 WASHERS.
D	4	PLASTIC NUT COVERS FOR 1" NUTS.
E	4	LEVELLING SHIMS.
F	4	1"φ NUTS AND WASHERS.

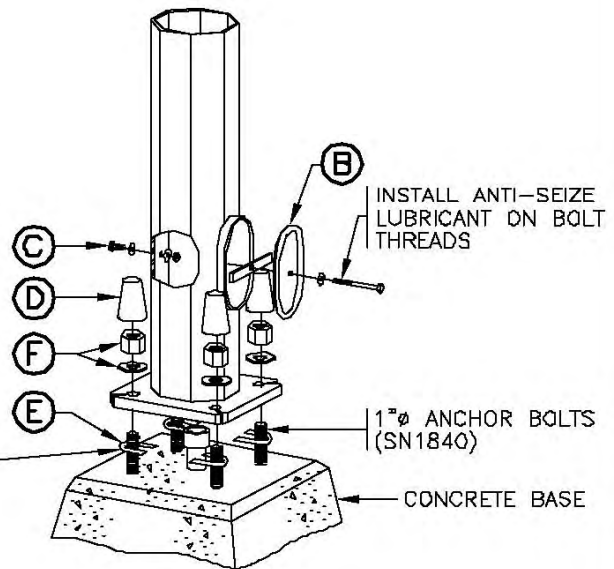

POLE ASSEMBLY DETAIL

NOTES

1. SEE STANDARD SPECIFICATIONS & SPECIAL PROVISIONS FOR ADDITIONAL INFORMATION.
2. POLE SHAFT SHALL BE INSTALLED PLUMB.
3. ALL SHAFTS, ARMS AND EXTENSIONS SHALL BE SUPPLIED WITH A GALVANIZED FINISH. aaaa
4. APPLY GREASE TO ANCHOR BOLT THREADS.
5. TOUCH UP ANY SCRATCHES IN GALVANIZED SURFACES WITH COLD GALVANIZING COMPOUND.

NOT TO SCALE



No.	Revision	Date
E		
D		
C	ANTI-SEIZING LUBRICANT NOTED ON HANDHOLE BOLT	NOV 98
B	HANDHOLE BOLT LENGTH REVISED	AUG 96
A	GENERAL REVISIONS	AUG 94

**TYPE 2 SHAFT INSTALLATION DETAILS
(7.5 m, 9.0 m AND 11.0 m LUMINAIRE POLES)**

Date: **30/09/93** Approved: **E.L. (Signature on File)**
Chief Highway Engineer

SPECIFICATION DRAWING No. **SP635-2.1.4**

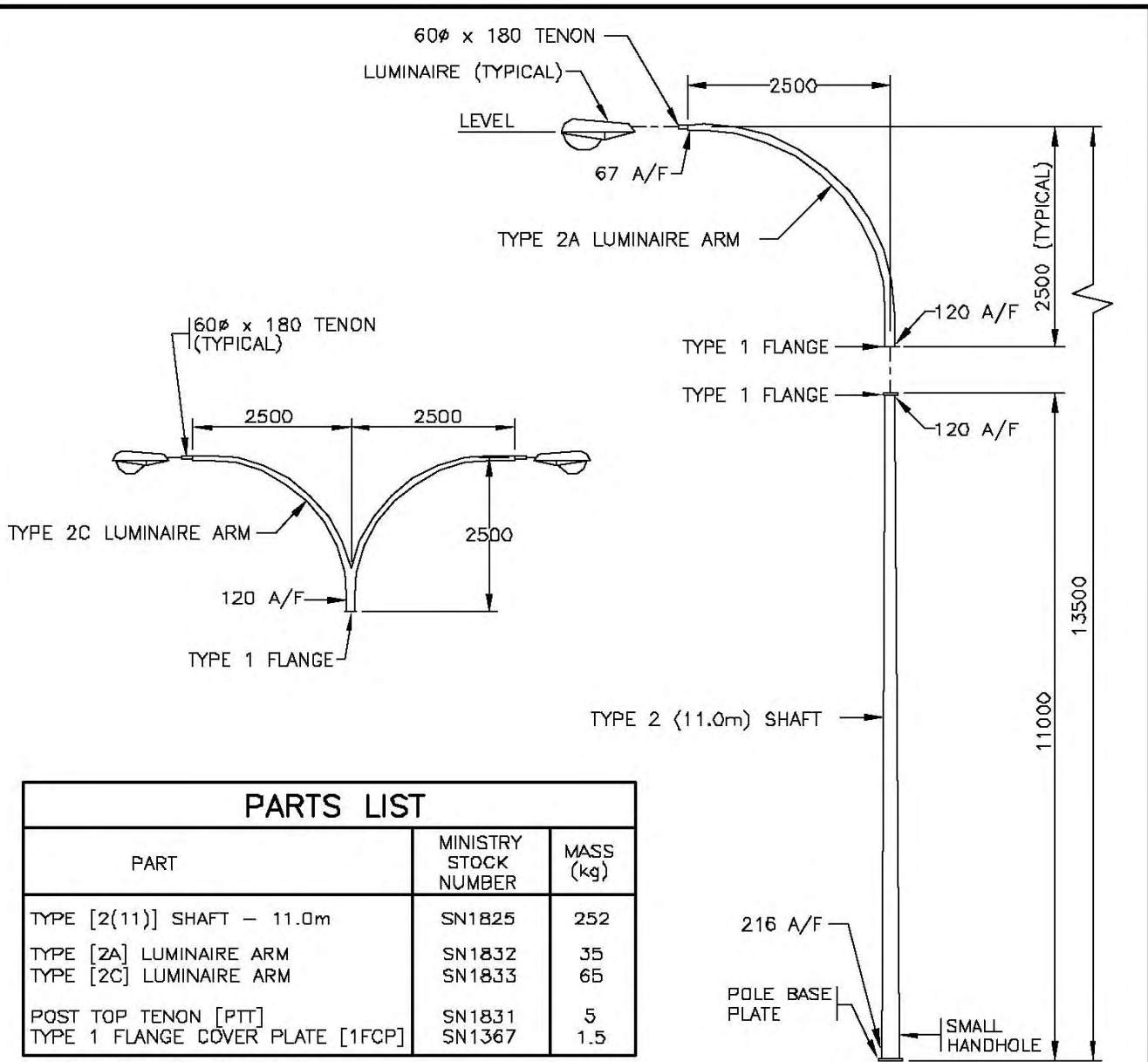

PARTS LIST		
PART	MINISTRY STOCK NUMBER	MASS (kg)
TYPE [2(11)] SHAFT - 11.0m	SN1825	252
TYPE [2A] LUMINAIRE ARM	SN1832	35
TYPE [2C] LUMINAIRE ARM	SN1833	65
POST TOP TENON [PTT]	SN1831	5
TYPE 1 FLANGE COVER PLATE [1FCP]	SN1367	1.5

* [] I.D. LABEL ON POLE

ELEVATION

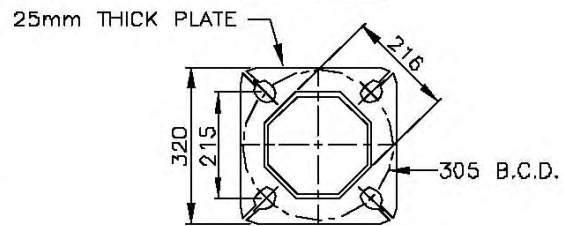

POLE BASE PLATE

NOTES

- SEE STANDARD SPECIFICATIONS & SPECIAL PROVISIONS FOR ADDITIONAL INFORMATION.
- SEE DRAWING SP635-2.1.6 FOR TYPE 2 SHAFT, BOLT KITS AND POLE ASSEMBLY DETAILS. aaaa
- ALL DIMENSIONS ARE IN MILLIMETRES UNLESS OTHERWISE NOTED.

NOT TO SCALE



No.	Revision	Date
F		
E		
D		
C		
B		
A	GENERAL REVISIONS	AUG 94

**TYPE 2 SHAFT INSTALLATION DETAILS
(13.5 m LUMINAIRE POLE)**

Date **30/09/93** Approved **E.L. (Signature on File)**
Chief Highway Engineer

SPECIFICATION DRAWING No. **SP635-2.1.5**

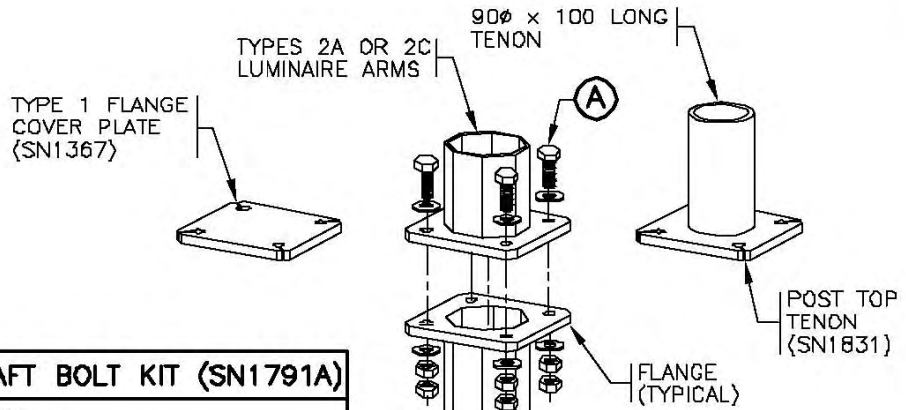

TYPE 2 (11.0m) SHAFT BOLT KIT (SN1791A)		
ITEM	QUANTITY	DESCRIPTION
A	4	5/8"φ x 3" LONG BOLT, 2 NUTS AND 2 WASHERS.
B	1	SMALL HANDHOLE COVER WITH 3/8"φ x 3 1/2" LONG BOLT, WASHER & BACKER BAR.
C	1	3/8"φ x 1 1/4" LONG BONDING BOLT WITH 1 NUT AND 2 WASHERS.
D	4	PLASTIC NUT COVERS FOR 1 1/4" NUTS.
E	4	LEVELLING SHIMS.
F	4	1 1/4"φ NUTS AND WASHERS.

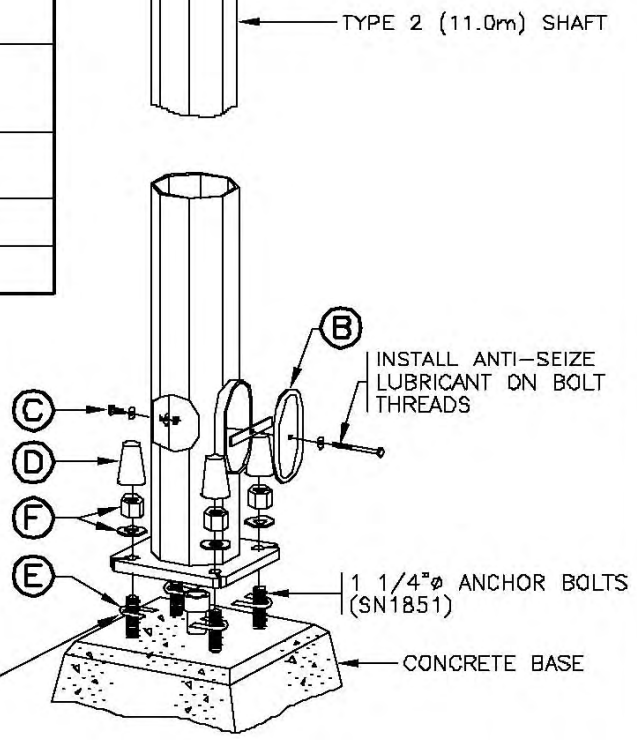

NOTES

- SEE STANDARD SPECIFICATIONS & SPECIAL PROVISIONS FOR ADDITIONAL INFORMATION.
- POLE SHAFT SHALL BE INSTALLED PLUMB.
- ALL SHAFTS, ARMS AND EXTENSIONS SHALL BE SUPPLIED WITH A GALVANIZED FINISH. aaaa
- APPLY GREASE TO ANCHOR BOLT THREADS.
- TOUCH UP ANY SCRATCHES IN GALVANIZED SURFACES WITH COLD GALVANIZING COMPOUND.

POLE ASSEMBLY DETAIL

NOT TO SCALE



No.	Revision	Date	TYPE 2 SHAFT INSTALLATION DETAILS (13.5 m LUMINAIRE POLE)		SPECIFICATION DRAWING No.
E			Date	Approved	SP635-2.1.6
D			30/09/93	E.L. (Signature on File)	
C	ANTI-SEIZING LUBRICANT NOTED ON HANDHOLE BOLT	NOV 98	Chief Highway Engineer		
B	HANDHOLE BOLT LENGTH REVISED	AUG 96			
A	GENERAL REVISIONS	AUG 94			

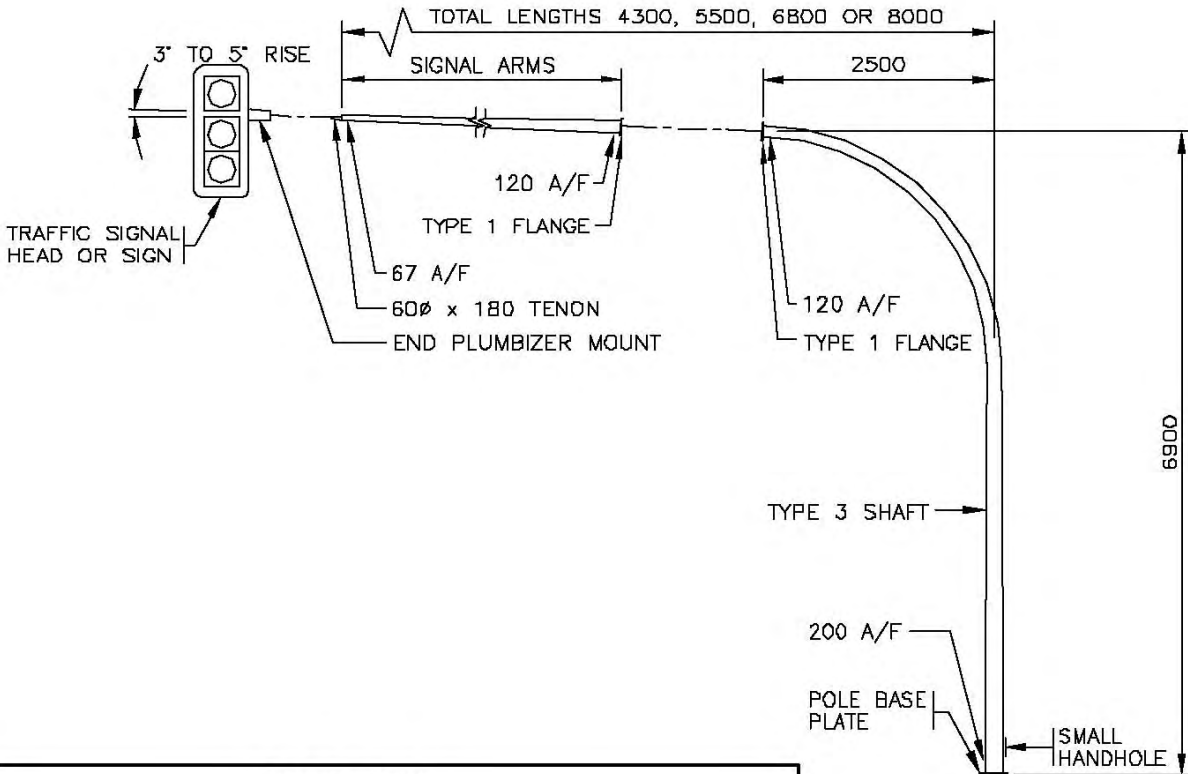

ELEVATION

PARTS LIST		
PART	MINISTRY STOCK NUMBER	MASS (kg)
TYPE [3] SHAFT	SN1B26	186
TYPE [3C] SIGNAL ARM - 1.8m	SN1836	18
TYPE [3A] SIGNAL ARM - 3.0m	SN1834	27
TYPE [3D] SIGNAL ARM - 4.3m	SN1837	54
TYPE [3E] SIGNAL ARM - 5.5m	SN1838	68
TYPE [3F] SIGNAL ARM - 0.3m to 3.0m (LENGTH VARIES)	SN1836A	9 PER METRE

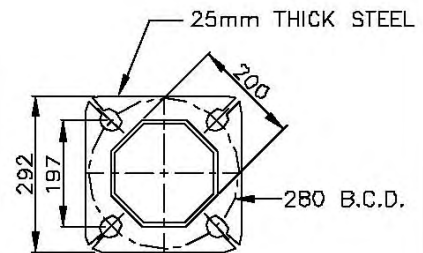

POLE BASE PLATE

* [] I.D. LABEL ON POLE

NOTES

- SEE STANDARD SPECIFICATIONS & SPECIAL PROVISIONS FOR ADDITIONAL INFORMATION.
- SEE DRAWING SP635-2.1.8 FOR TYPE 3 SHAFT, BOLT KITS AND POLE ASSEMBLY DETAILS. aaaa
- ALL DIMENSIONS ARE IN MILLIMETRES UNLESS OTHERWISE NOTED.

NOT TO SCALE



No.	Revision	Date	TYPE 3 SHAFT INSTALLATION DETAILS (SIGNAL POLE)		SPECIFICATION DRAWING No. SP635-2.1.7
F			Date	Approved	
E			30/09/93	E.L. (Signature on File) Chief Highway Engineer	
D	SIGNAL HEAD MOUNTING REVISED	OCT 03			
C	3F ARM ADDED	AUG 96			
B	SIGNAL HEAD REVISED	AUG 95			
A	GENERAL REVISIONS	AUG 94			

TYPES 3A, 3C AND 3D
SIGNAL ARMS

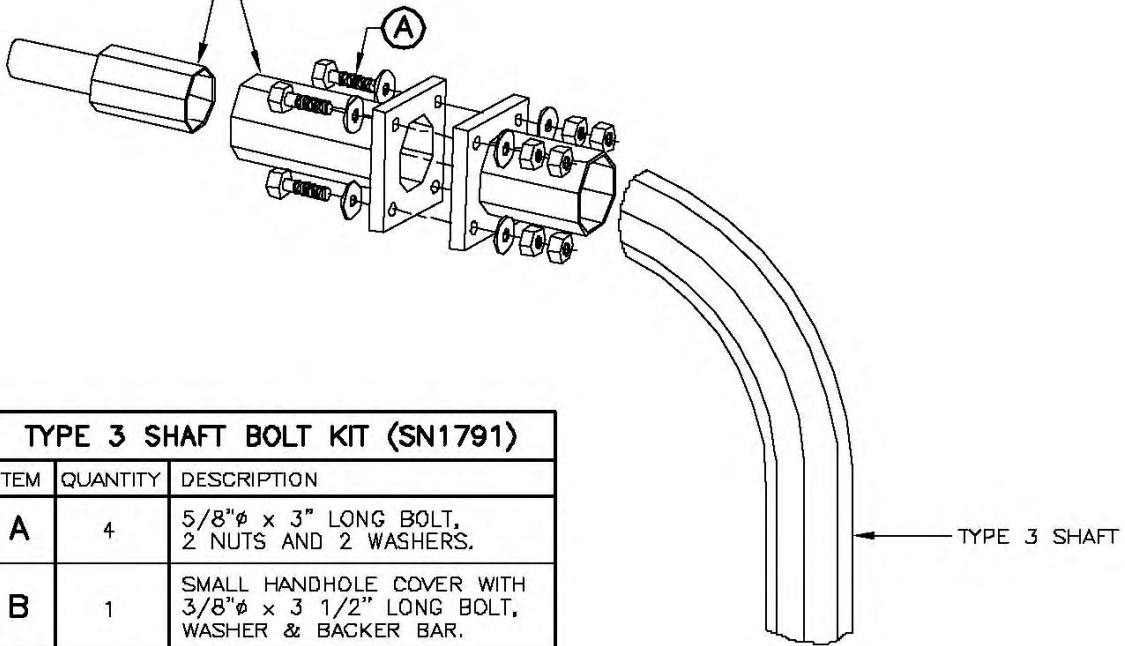

TYPE 3 SHAFT BOLT KIT (SN1791)		
ITEM	QUANTITY	DESCRIPTION
A	4	5/8"φ x 3" LONG BOLT, 2 NUTS AND 2 WASHERS.
B	1	SMALL HANDHOLE COVER WITH 3/8"φ x 3 1/2" LONG BOLT, WASHER & BACKER BAR.
C	1	3/8"φ x 1 1/4" LONG BONDING BOLT WITH 1 NUT AND 2 WASHERS.
D	4	PLASTIC NUT COVERS FOR 1" NUTS.
E	4	LEVELLING SHIMS.
F	4	1"φ NUTS AND WASHERS.

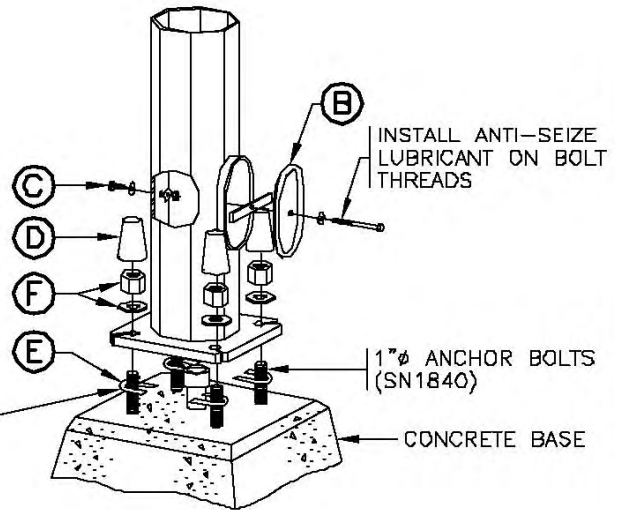

MAXIMUM 4 SHIMS
PER BOLT

POLE ASSEMBLY DETAIL

NOTES

1. SEE STANDARD SPECIFICATIONS & SPECIAL PROVISIONS FOR ADDITIONAL INFORMATION.
2. POLE SHAFT SHALL BE INSTALLED PLUMB.
3. ALL SHAFTS, ARMS AND EXTENSIONS SHALL BE SUPPLIED WITH A GALVANIZED FINISH. aaaa
4. APPLY GREASE TO ANCHOR BOLT THREADS.
5. TOUCH UP ANY SCRATCHES IN GALVANIZED SURFACES WITH COLD GALVANIZING COMPOUND.

NOT TO SCALE



No.	Revision	Date
E		
D		
C	ANTI-SEIZING LUBRICANT NOTED ON HANDHOLE BOLT	NOV 98
B	HANDHOLE BOLT LENGTH REVISED	AUG 96
A	GENERAL REVISIONS	AUG 94

TYPE 3 SHAFT INSTALLATION DETAILS (SIGNAL POLE)		
Date	Approved	SPECIFICATION DRAWING No.
30/09/93	E.L. (Signature on File) Chief Highway Engineer	SP635-2.1.8

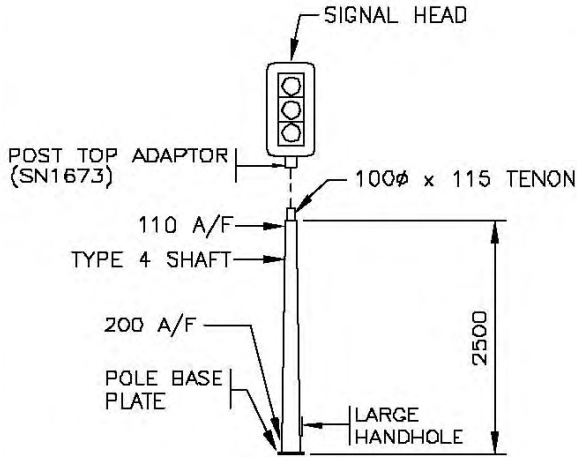

TYPE 4 SHAFT

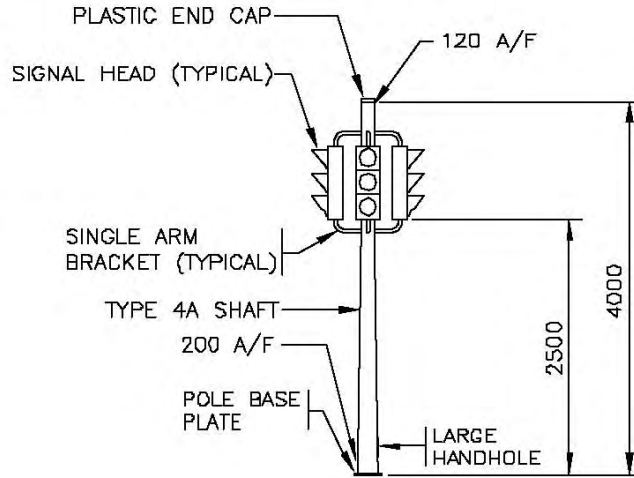

TYPE 4A SHAFT

FOR REFERENCE ONLY
 USE TYPE 4A SHAFT IN PLACE OF TYPE 4 SHAFT AND MOUNT SIGNAL HEADS WITH SINGLE ARM BRACKETS

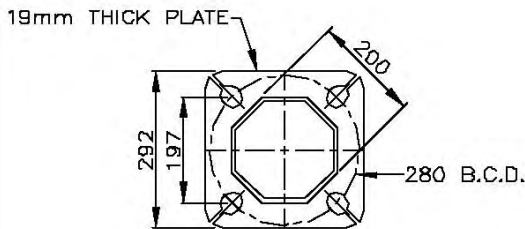

POLE BASE PLATE

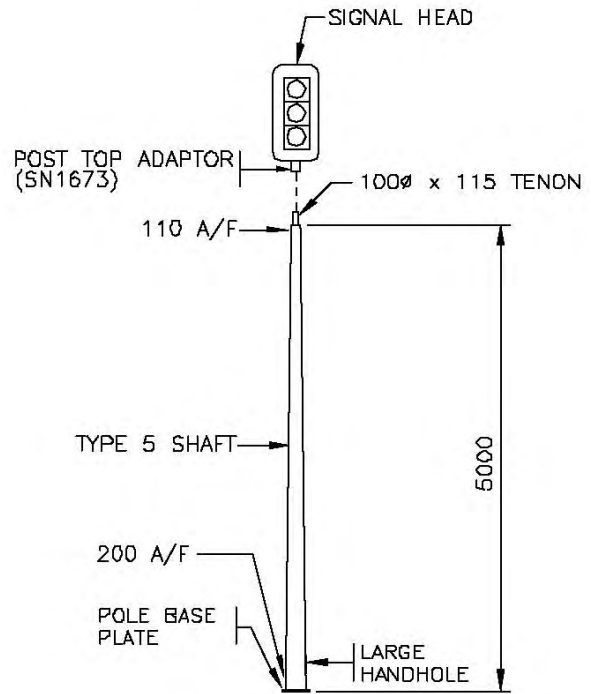

TYPE 5 SHAFT

FOR REFERENCE ONLY
 USE TYPE 2-6.5m SHAFT IN PLACE OF TYPE 5 SHAFT AND MOUNT SIGNAL HEADS WITH SINGLE ARM BRACKETS

PARTS LIST		
PART	MINISTRY STOCK NUMBER	MASS (kg)
TYPE [4] SHAFT	SN1827	45
TYPE [4A] SHAFT	SN1827A	66
TYPE [5] SHAFT	SN1828	77

* [] I.D. LABEL ON POLE

NOTES

- SEE STANDARD SPECIFICATIONS & SPECIAL PROVISIONS FOR ADDITIONAL INFORMATION.
- SEE DRAWING SP635-2.1.10 FOR TYPE 4, 4A AND 5 SHAFT, BOLT KITS AND POLE ASSEMBLY DETAILS.
- ALL DIMENSION ARE IN MILLIMETRES UNLESS OTHERWISE NOTED.

NOT TO SCALE



No.	Revision	Date
F		
E		
D		
C		
B	ALTERNATES NOTED	OCT 03
A	GENERAL REVISIONS	AUG 94

TYPE 4, 4A AND 5 SHAFT INSTALLATION DETAILS		
Date	Approved	SPECIFICATION DRAWING No.
30/09/93	E.L. (Signature on File) Chief Highway Engineer	SP635-2.1.9

TYPE 4 & 5 SHAFT BOLT KIT (SN1791B)

ITEM	QUANTITY	DESCRIPTION
B	1	LARGE HANDHOLE COVER WITH 2-3/8"ø x 1 1/4" LONG BOLTS AND 2 WASHERS.
C	1	3/8"ø x 1 1/4" LONG BONDING BOLT WITH 1 NUT AND 3 WASHERS.
D	4	PLASTIC NUT COVERS FOR 1" NUTS.
E	4	LEVELLING SHIMS.
F	4	1"ø NUTS AND WASHERS.

TYPE 4A SHAFT BOLT KIT (SN1791C)

ITEM	QUANTITY	DESCRIPTION
A	1	PLASTIC END CAP
B	1	LARGE HANDHOLE COVER WITH 2-3/8"ø x 1 1/4" LONG BOLTS AND 2 WASHERS.
C	1	3/8"ø x 1" LONG BONDING BOLT WITH 1 NUT AND 2 WASHERS.
D	4	PLASTIC NUT COVERS FOR 1" NUTS.
E	4	LEVELLING SHIMS.
F	4	1"ø NUTS AND WASHERS.

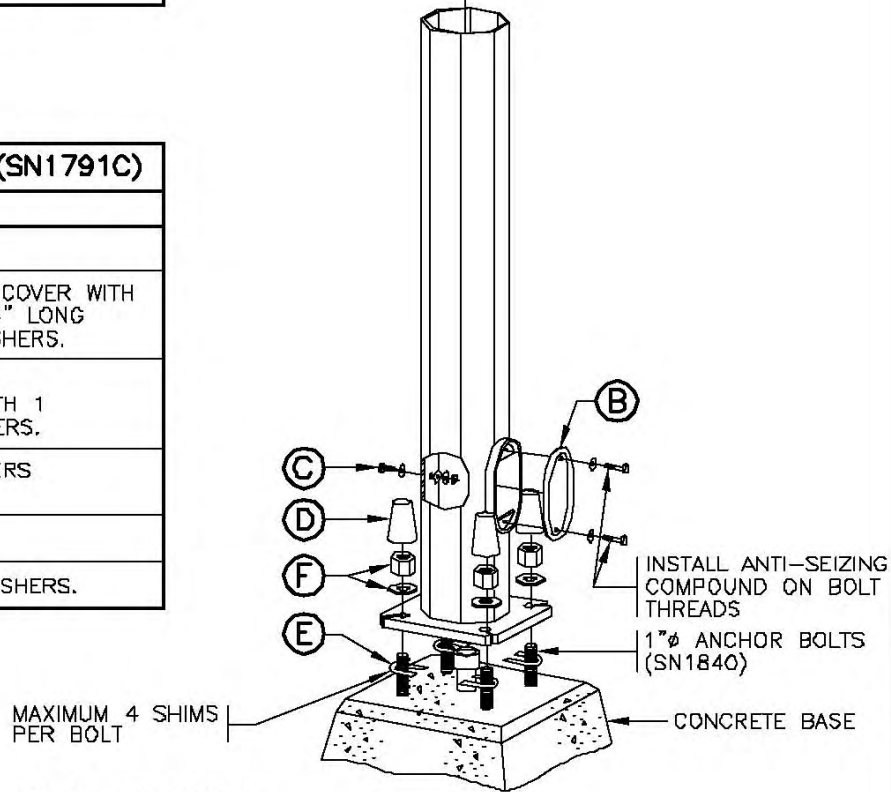
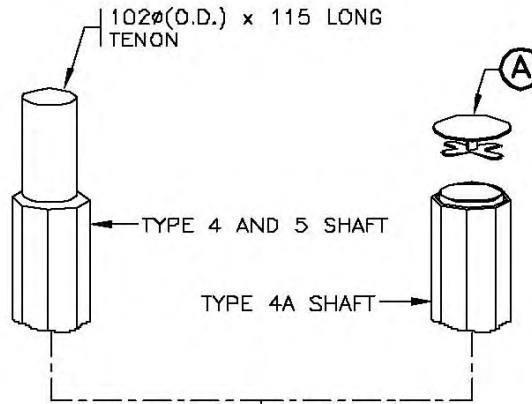

POLE ASSEMBLY DETAIL

NOTES

1. SEE STANDARD SPECIFICATIONS & SPECIAL PROVISIONS FOR ADDITIONAL INFORMATION.
2. POLE SHAFT SHALL BE INSTALLED PLUMB.
3. ALL SHAFTS, ARMS AND EXTENSIONS SHALL BE SUPPLIED WITH A GALVANIZED FINISH. aaaa
4. APPLY GREASE TO ANCHOR BOLT THREADS.
5. TOUCH UP ANY SCRATCHES IN GALVANIZED SURFACES WITH COLD GALVANIZING COMPOUND.

NOT TO SCALE



No.	Revision	Date
E		
D		
C	ANTI-SEIZING COMPOUND NOTED ON HANDHOLE BOLTS	NOV 98
B	HANDHOLE BOLT LENGTH REVISED	AUG 95
A	GENERAL REVISIONS	AUG 94

TYPE 4, 4A AND 5 SHAFT INSTALLATION DETAILS (SIGNAL POSTS)

Date	Approved	SPECIFICATION DRAWING No.
30/09/93	E.L. (Signature on File) Chief Highway Engineer	SP635-2.1.10

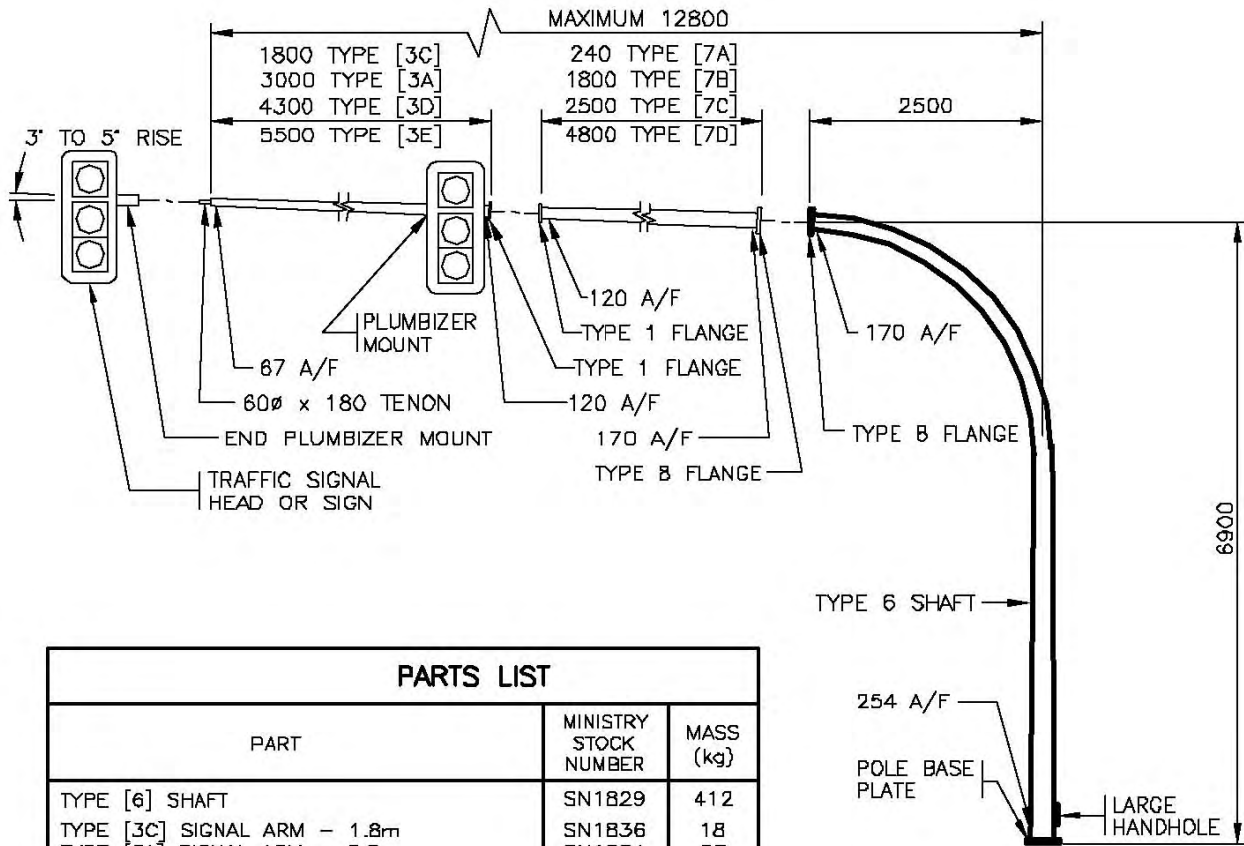

PARTS LIST		
PART	MINISTRY STOCK NUMBER	MASS (kg)
TYPE [6] SHAFT	SN1829	412
TYPE [3C] SIGNAL ARM - 1.8m	SN1836	18
TYPE [3A] SIGNAL ARM - 3.0m	SN1834	27
TYPE [3D] SIGNAL ARM - 4.3m	SN1837	54
TYPE [3E] SIGNAL ARM - 5.5m	SN1838	68
TYPE [3F] SIGNAL ARM - 0.3m to 3.0m (LENGTH VARIES)	SN1836A	9 PER METRE
TYPE [7A] EXTENSION - 0.24m	SN1890A	20
TYPE [7B] EXTENSION - 1.8m	SN1890B	69
TYPE [7C] EXTENSION - 2.5m	SN1890C	86
TYPE [7D] EXTENSION - 4.8m	SN1890D	154
TYPE 1 FLANGE COVER PLATE [1FCP]	SN1367	1.5
TYPE 8 FLANGE COVER PLATE [8FCP]	SN2089	2.5

* [] I.D. LABEL ON POLE

ELEVATION

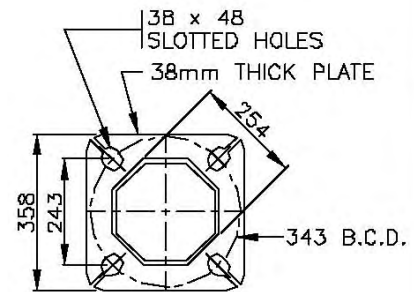

POLE BASE PLATE

NOTES

- SEE STANDARD SPECIFICATIONS & SPECIAL PROVISIONS FOR ADDITIONAL INFORMATION.
- SEE DRAWING SP635-2.1.12 FOR TYPE 6 SHAFT, BOLT KITS AND POLE ASSEMBLY DETAILS.
- ALL DIMENSIONS ARE IN MILLIMETRES UNLESS OTHERWISE NOTED.

aaaa

NOT TO SCALE



No.	Revision	Date	TYPE 6 SHAFT INSTALLATION DETAILS (SIGNAL POLE)		DATE	APPROVED	SPECIFICATION DRAWING No.
F							
E							
D	SIGNAL HEAD MOUNTING REVISED	OCT 03	Date	Approved	30/09/93 E.L. (Signature on File) Chief Highway Engineer	SP635-2.1.11	
C	3F ARM ADDED	AUG 96					
B	SIGNAL HEAD REVISED & PLATE HOLE SIZE ADDED	AUG 95					
A	GENERAL REVISIONS	AUG 94					

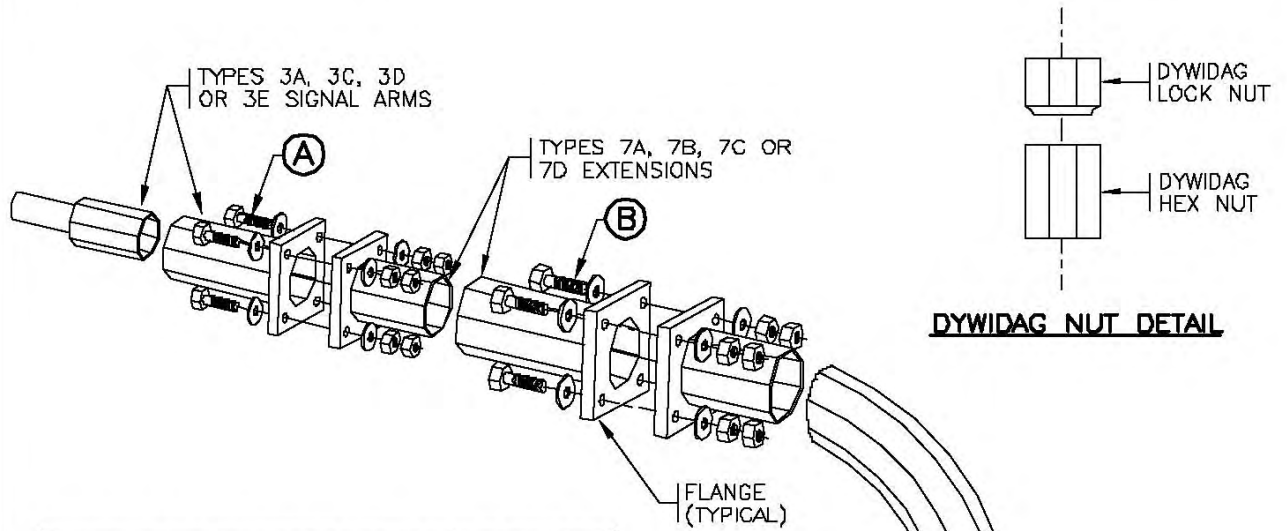

TYPE 6 SHAFT BOLT KIT (SN1792)		
ITEM	QUANTITY	DESCRIPTION
A	4	5/8"φ × 3" LONG BOLT, 2 NUTS AND 2 WASHERS.
B	4	1"φ × 5" LONG BOLT, 2 NUTS AND 2 WASHERS.
C	1	LARGE HANDHOLE COVER WITH 2-3/8"φ × 1" LONG BOLTS AND 2 WASHERS.
D	1	3/8"φ × 1 1/4" LONG BONDING BOLT WITH 1 NUT AND 2 WASHERS.
E	4	LEVELLING SHIMS.

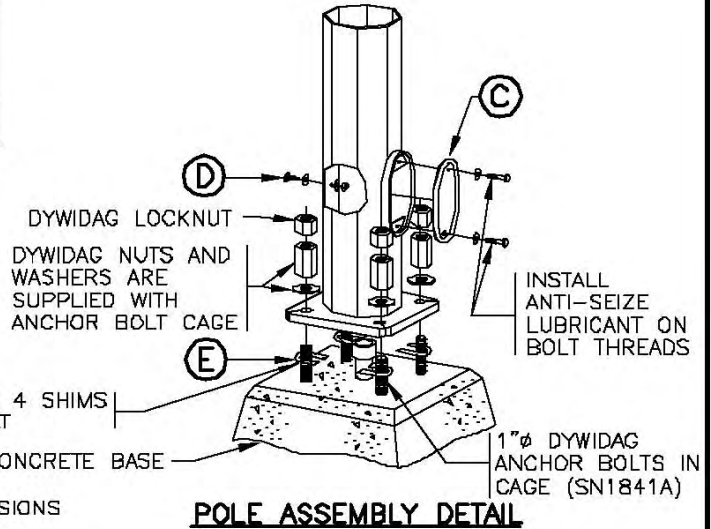

NOTES

1. SEE STANDARD SPECIFICATIONS & SPECIAL PROVISIONS FOR ADDITIONAL INFORMATION.
2. POLE SHAFT SHALL BE INSTALLED PLUMB.
3. ALL SHAFTS, ARMS AND EXTENSIONS SHALL BE SUPPLIED WITH A GALVANIZED FINISH.
4. APPLY GREASE TO ANCHOR BOLT THREADS. TO ANCHOR BOLT THREADS.
5. TOUCH UP ANY SCRATCHES IN GALVANIZED SURFACES WITH COLD GALVANIZING COMPOUND.

NOT TO SCALE



No.	Revision	Date
E		
D		
C	ANTI-SEIZING LUBRICANT NOTED ON HANDHOLE BOLT	NOV 98
B	HANDHOLE BOLT LENGTH REVISED	AUG 95
A	GENERAL REVISIONS	AUG 94

TYPE 6 SHAFT INSTALLATION DETAILS (SIGNAL POLE)		
Date	Approved	SPECIFICATION DRAWING No.
30/09/93	E.L. (Signature on File) Chief Highway Engineer	SP635-2.1.12

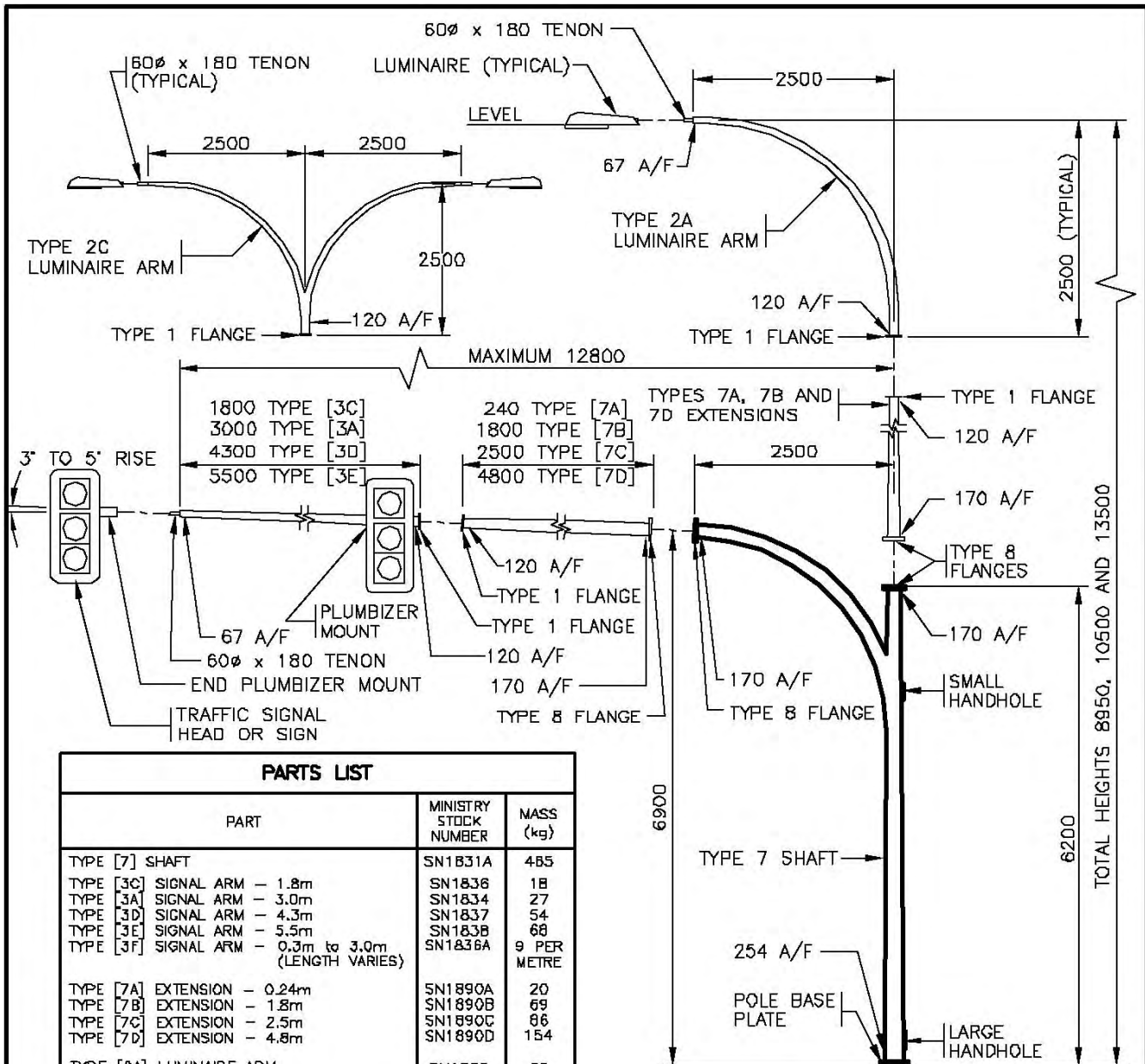

PARTS LIST		
PART	MINISTRY STOCK NUMBER	MASS (kg)
TYPE [7] SHAFT	SN1831A	485
TYPE [3C] SIGNAL ARM - 1.8m	SN1836	18
TYPE [3A] SIGNAL ARM - 3.0m	SN1834	27
TYPE [3D] SIGNAL ARM - 4.3m	SN1837	54
TYPE [3E] SIGNAL ARM - 5.5m	SN1838	68
TYPE [3F] SIGNAL ARM - 0.3m to 3.0m (LENGTH VARIES)	SN1836A	9 PER METRE
TYPE [7A] EXTENSION - 0.24m	SN1890A	20
TYPE [7B] EXTENSION - 1.8m	SN1890B	69
TYPE [7C] EXTENSION - 2.5m	SN1890C	86
TYPE [7D] EXTENSION - 4.8m	SN1890D	154
TYPE [2A] LUMINAIRE ARM	SN1832	35
TYPE [2C] LUMINAIRE ARM	SN1833	65
POST TOP TENON [PTT]	SN1831	5
TYPE 1 FLANGE COVER PLATE [1FCP]	SN1367	1.5
TYPE 8 FLANGE COVER PLATE [8FCP]	SN2089	2.5

* [] I.D. LABEL ON POLE

NOTES

- SEE STANDARD SPECIFICATIONS & SPECIAL PROVISIONS FOR ADDITIONAL INFORMATION.
- SEE DRAWING SP635-2.1.14 FOR TYPE 7 SHAFT, BOLT KITS AND POLE ASSEMBLY DETAILS. aaaa
- ALL DIMENSIONS ARE IN MILLIMETRES UNLESS OTHERWISE NOTED.

NOT TO SCALE

ELEVATION

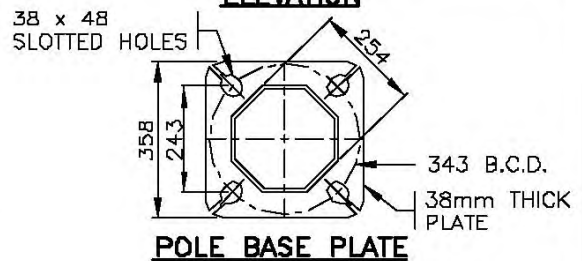

POLE BASE PLATE



No.	Revision	Date
F		
E		
D	SIGNAL HEAD MOUNTING REVISED	OCT 03
C	3F ARM ADDED	AUG 96
B	SIGNAL HEAD REVISED & PLATE HOLE SIZE ADDED	AUG 95
A	GENERAL REVISIONS	AUG 94

TYPE 7 SHAFT INSTALLATION DETAILS (SIGNAL POLE)		
Date	Approved	SPECIFICATION DRAWING No.
30/09/93	E.L. (Signature on File) Chief Highway Engineer	SP635-2.1.13

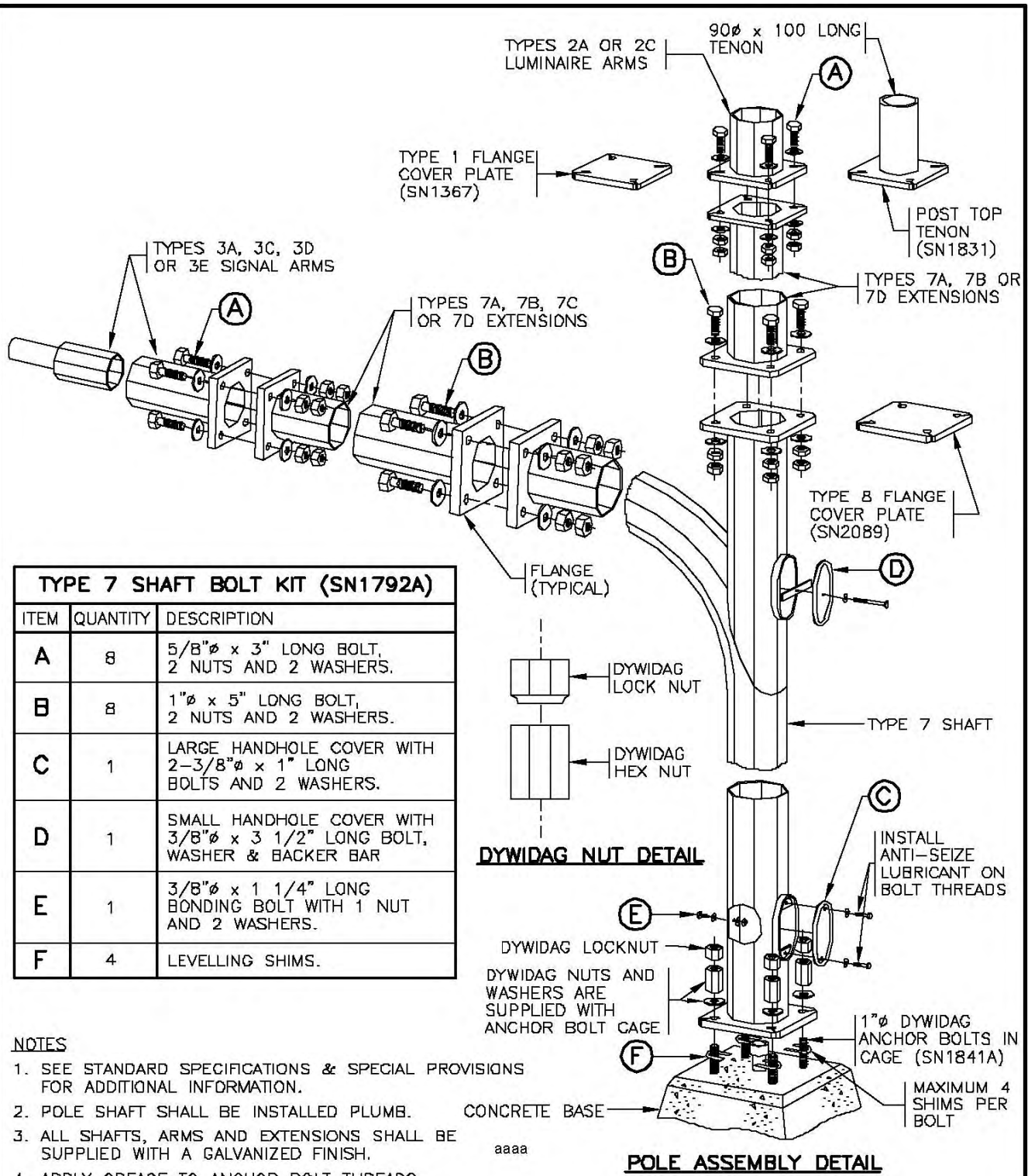

TYPE 7 SHAFT BOLT KIT (SN1792A)		
ITEM	QUANTITY	DESCRIPTION
A	8	5/8"φ x 3" LONG BOLT, 2 NUTS AND 2 WASHERS.
B	8	1"φ x 5" LONG BOLT, 2 NUTS AND 2 WASHERS.
C	1	LARGE HANDHOLE COVER WITH 2-3/8"φ x 1" LONG BOLTS AND 2 WASHERS.
D	1	SMALL HANDHOLE COVER WITH 3/8"φ x 3 1/2" LONG BOLT, WASHER & BACKER BAR
E	1	3/8"φ x 1 1/4" LONG BONDING BOLT WITH 1 NUT AND 2 WASHERS.
F	4	LEVELLING SHIMS.

NOTES

1. SEE STANDARD SPECIFICATIONS & SPECIAL PROVISIONS FOR ADDITIONAL INFORMATION.
2. POLE SHAFT SHALL BE INSTALLED PLUMB.
3. ALL SHAFTS, ARMS AND EXTENSIONS SHALL BE SUPPLIED WITH A GALVANIZED FINISH.
4. APPLY GREASE TO ANCHOR BOLT THREADS.
5. TOUCH UP ANY SCRATCHES IN GALVANIZED SURFACES WITH COLD GALVANIZING COMPOUND.

NOT TO SCALE

No.	Revision	Date
E	7C LUM EXTENSION CHANGED TO 7B	OCT 03
D	ANTI-SEIZING LUBRICANT NOTED ON HANDHOLE BOLT	NOV 98
C	SMALL HANDHOLE BOLT LENGTH REVISED	AUG 96
B	HANDHOLE BOLT LENGTH REVISED	AUG 95
A	GENERAL REVISIONS	AUG 94

TYPE 7 SHAFT INSTALLATION DETAILS (SIGNAL POLE)

Date **30/09/93** Approved **E.L. (Signature on File)**
Chief Highway Engineer

SPECIFICATION DRAWING No. **SP635-2.1.14**



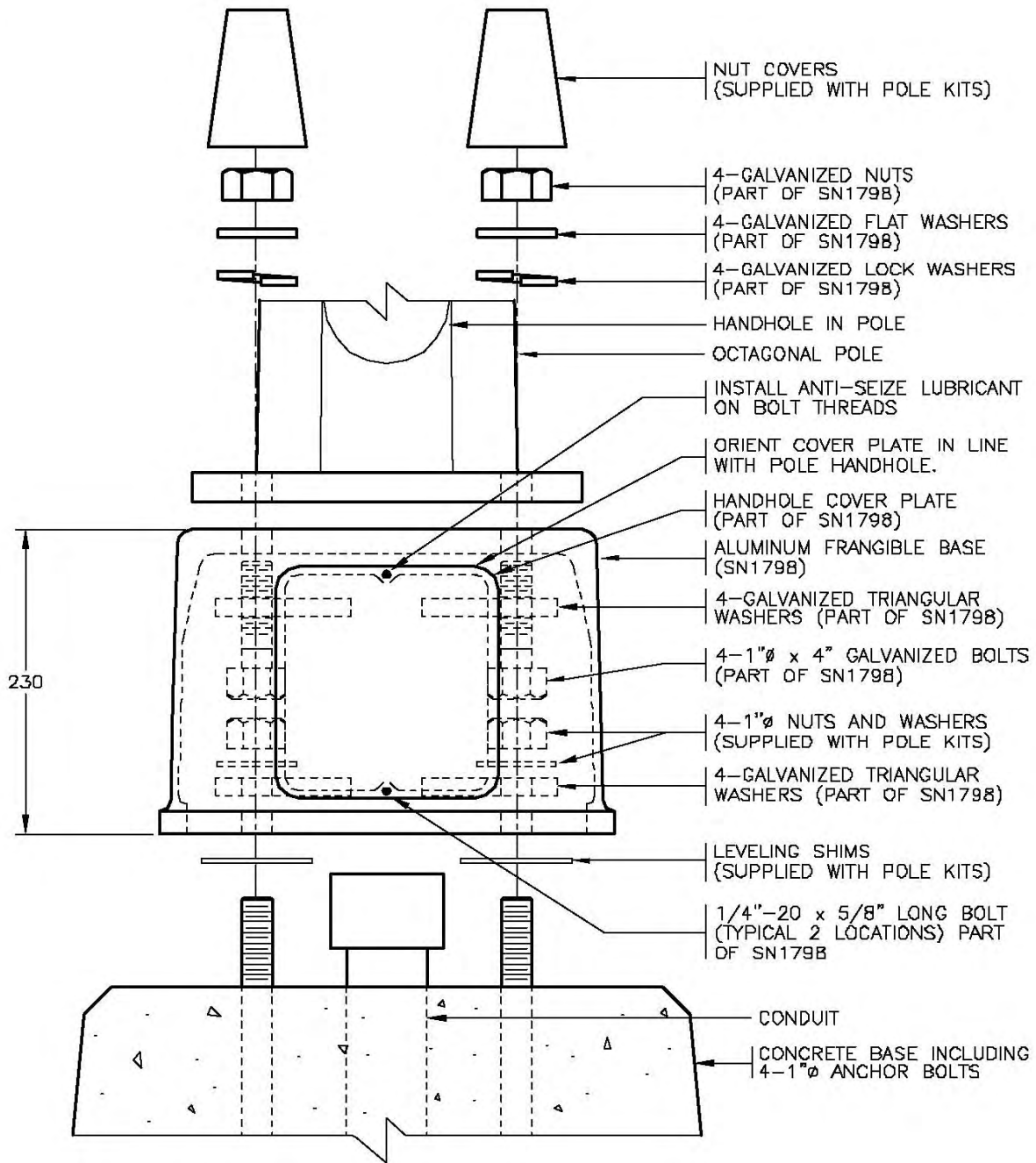

FRANGIBLE BASE ASSEMBLY
(SN179B)

aaaa

NOTES:

- SEE STANDARD SPECIFICATIONS & SPECIAL PROVISIONS FOR ADDITIONAL INFORMATION.

NOT TO SCALE



No.	Revision	Date
E		
D	LOCK WASHERS ADDED	SEPT 00
C	ANTI-SEIZING LUBRICANT NOTED ON COVER PLATE BOLTS	NOV 98
B	SPRING LOCK WASHERS REMOVED	AUG 95
A	GENERAL REVISIONS	AUG 94

ALUMINUM FRANGIBLE BASE FOR 9.0 m AND 11.0 m LUMINAIRE POLES

Date: **30/09/93** Approved: **E.L. (Signature on File)**
Chief Highway Engineer

SPECIFICATION DRAWING No. **SP635-2.1.15**

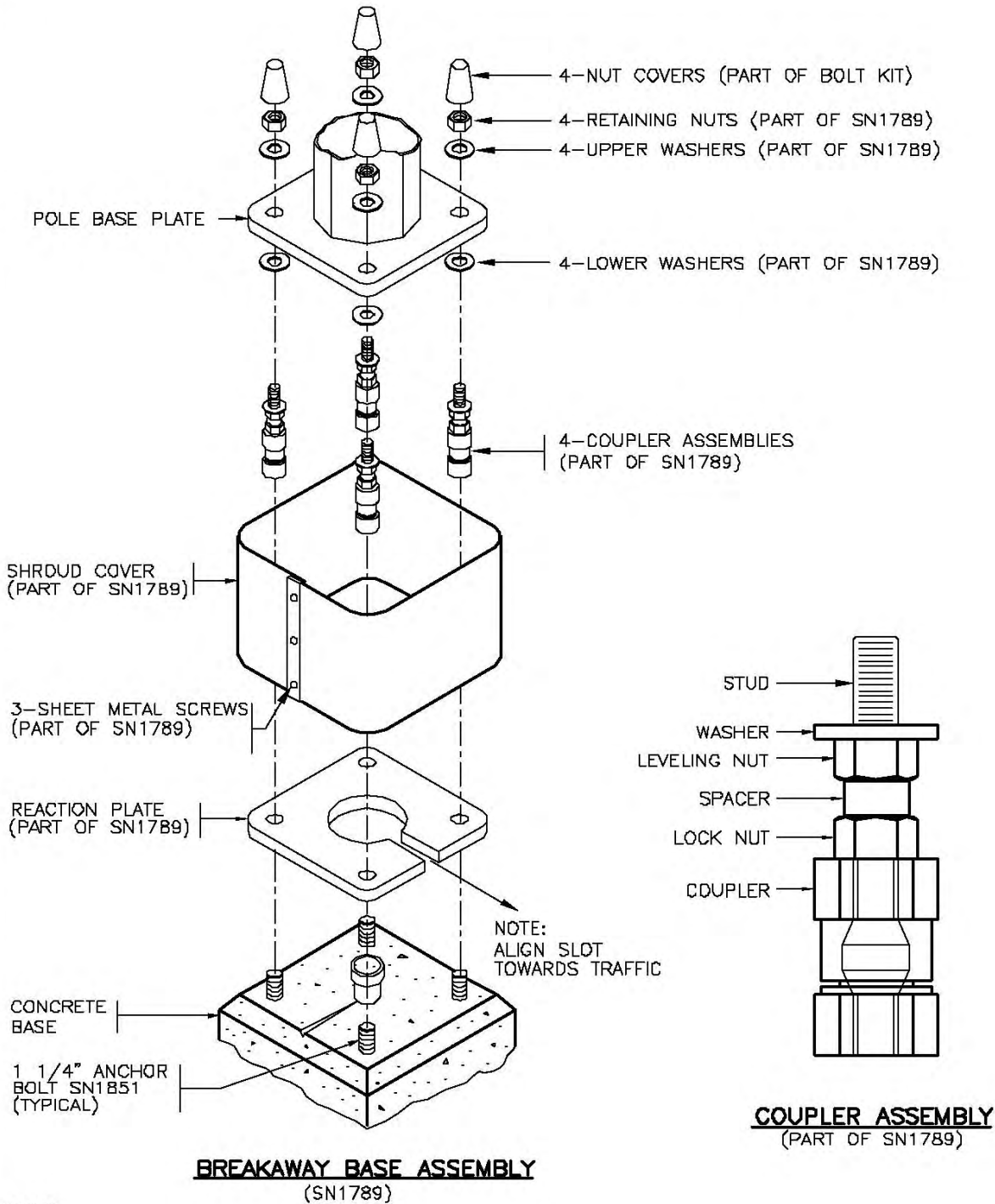

NOTES:

1. SEE STANDARD SPECIFICATIONS & SPECIAL PROVISIONS FOR ADDITIONAL INFORMATION. ^{aaaa}
2. INSTALL BASE AND TIGHTEN BOLTS AS PER MANUFACTURERS INSTRUCTIONS.

NOT TO SCALE



No.	Revision	Date
F		
E		
D		
C		
B	NOTE 2, COUPLERS & REACTION PLATE REV'D	JAN 97
A	GENERAL REVISIONS	AUG 94

BREAKAWAY BASE FOR 13.5 m LUMINAIRE POLES		
Date	Approved	SPECIFICATION DRAWING No.
30/09/93	E.L. (Signature on File) Chief Highway Engineer	SP635-2.1.16

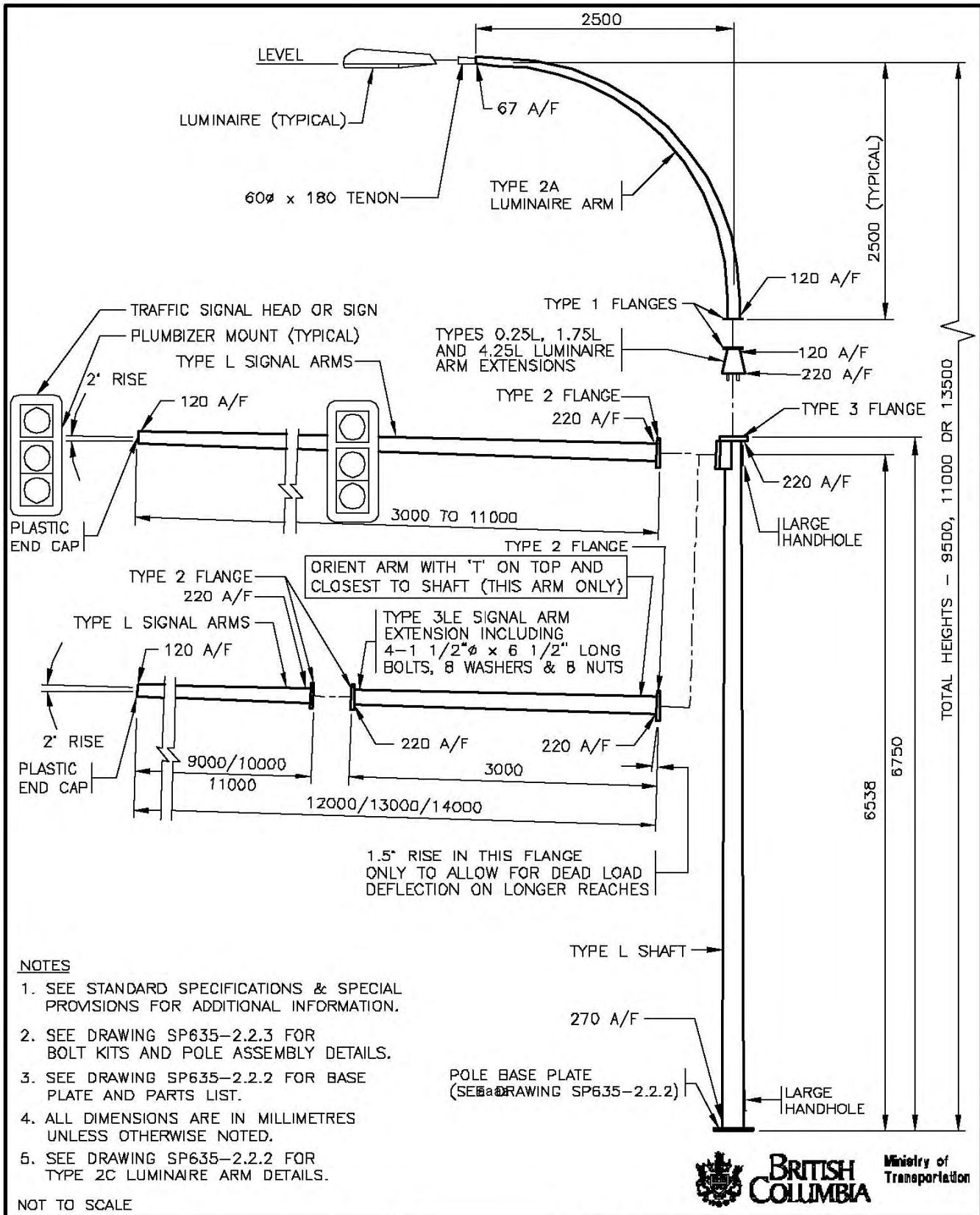

NOTES

1. SEE STANDARD SPECIFICATIONS & SPECIAL PROVISIONS FOR ADDITIONAL INFORMATION.
2. SEE DRAWING SP635-2.2.3 FOR BOLT KITS AND POLE ASSEMBLY DETAILS.
3. SEE DRAWING SP635-2.2.2 FOR BASE PLATE AND PARTS LIST.
4. ALL DIMENSIONS ARE IN MILLIMETRES UNLESS OTHERWISE NOTED.
5. SEE DRAWING SP635-2.2.2 FOR TYPE 2C LUMINAIRE ARM DETAILS.

NOT TO SCALE

No.	Revision	Date
F		
E		
D	SIGNAL HEAD MOUNTING ADDED	OCT 03
C	BOLTS ON EXTENSION ARM REVISED	AUG 96
B	NOTE 5 ADDED & 3LE ARM REVISED	AUG 95
A	GENERAL REVISIONS	AUG 94

TYPE L SIGNAL POLE INSTALLATION DETAILS		SPECIFICATION DRAWING No.
Date	Approved	SP635-2.2.1
30/09/93	E.L. (Signature on File) Chief Highway Engineer	



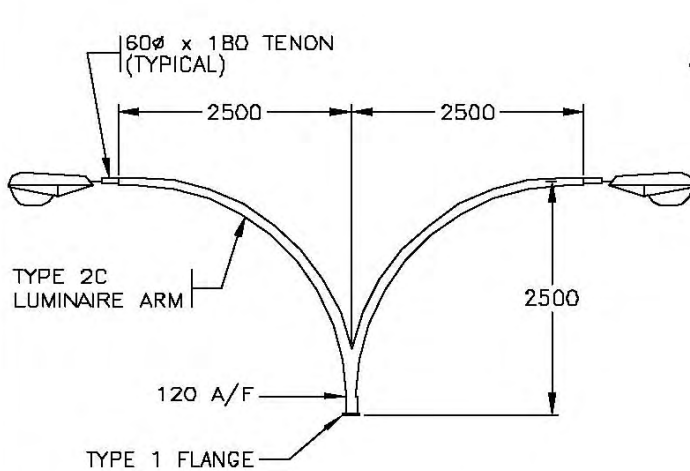

TYPE 2C LUMINAIRE ARM DETAILS

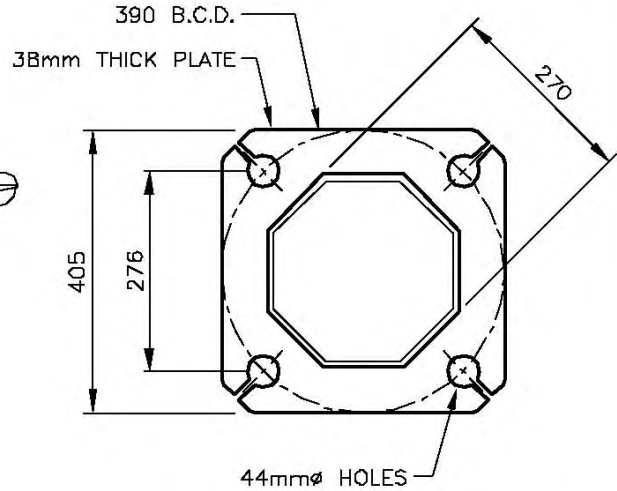

TYPE L POLE BASE PLATE

PARTS LIST FOR TYPE L SIGNAL POLE		
PART	MINISTRY STOCK NUMBER	MASS (kg)
TYPE [L] POLE SHAFT	SN2052	442
TYPE [3L] SIGNAL ARM - 3.0m	SN2053	97
TYPE [4L] SIGNAL ARM - 4.0m	SN2054	118
TYPE [5L] SIGNAL ARM - 5.0m	SN2055	173
TYPE [6L] SIGNAL ARM - 6.0m	SN2056	201
TYPE [7L] SIGNAL ARM - 7.0m	SN2057	229
TYPE [8L] SIGNAL ARM - 8.0m	SN2058	259
TYPE [9L] SIGNAL ARM - 9.0m	SN2059	284
TYPE [10L] SIGNAL ARM - 10.0m	SN2060	377
TYPE [11L] SIGNAL ARM - 11.0m	SN2061	410
TYPE [3LE] SIGNAL ARM EXTENSION - 3.0m	SN2065	114
TYPE [4.25L] LUMINAIRE ARM EXTENSION - 4.25m	SN2062	82
TYPE [1.75L] LUMINAIRE ARM EXTENSION - 1.75m	SN2063	29
TYPE [0.25L] LUMINAIRE ARM EXTENSION - 0.25m	SN2064	10
TYPE [2A] LUMINAIRE ARM	SN1832	35
TYPE [2C] LUMINAIRE ARM	SN1833	65
TYPE 1 FLANGE COVER PLATE [1 FCP]	SN1367	1.5
TYPE 2 FLANGE COVER PLATE [2 FCP]	SN2083	4
TYPE 3 FLANGE COVER PLATE [3 FCP]	SN2084	4
POST TOP TENON [PTT]	SN1831	5

* [] I.D. LABEL ON POLE

NOT TO SCALE



No.	Revision	Date	TYPE L SIGNAL POLE INSTALLATION DETAILS		SPECIFICATION DRAWING No.
F			Date	Approved	SP635-2.2.2
E			30/09/93	E.L. (Signature on File)	
D				Chief Highway Engineer	
C					
B	HOLE SIZE REVISED & 2C ARM ADDED	AUG 95			
A	GENERAL REVISIONS	AUG 94			

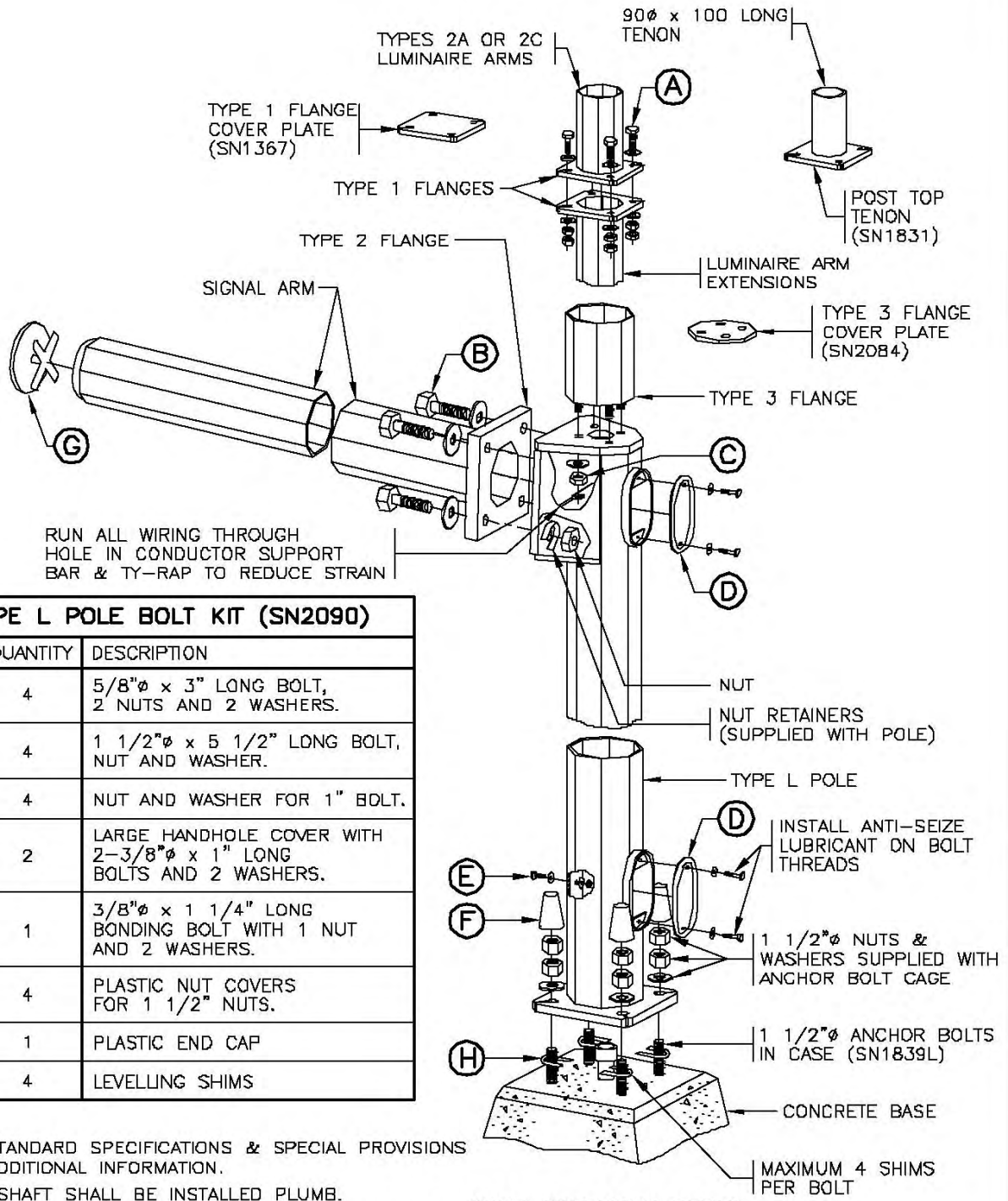

TYPE L POLE BOLT KIT (SN2090)		
ITEM	QUANTITY	DESCRIPTION
A	4	5/8"φ × 3" LONG BOLT, 2 NUTS AND 2 WASHERS.
B	4	1 1/2"φ × 5 1/2" LONG BOLT, NUT AND WASHER.
C	4	NUT AND WASHER FOR 1" BOLT.
D	2	LARGE HANDHOLE COVER WITH 2-3/8"φ × 1" LONG BOLTS AND 2 WASHERS.
E	1	3/8"φ × 1 1/4" LONG BONDING BOLT WITH 1 NUT AND 2 WASHERS.
F	4	PLASTIC NUT COVERS FOR 1 1/2" NUTS.
G	1	PLASTIC END CAP
H	4	LEVELLING SHIMS

NOTES

1. SEE STANDARD SPECIFICATIONS & SPECIAL PROVISIONS FOR ADDITIONAL INFORMATION.
2. POLE SHAFT SHALL BE INSTALLED PLUMB.
3. ALL SHAFTS, ARMS AND EXTENSIONS SHALL BE SUPPLIED WITH A GALVANIZED FINISH.
4. APPLY GREASE TO ANCHOR BOLT THREADS.
5. TOUCH UP ANY SCRATCHES IN GALVANIZED SURFACES WITH COLD GALVANIZING COMPOUND.

NOT TO SCALE

aaaa **POLE ASSEMBLY DETAIL**



No.	Revision	Date
E		
D	ANTI-SEIZING LUBRICANT NOTED ON HANDHOLE BOLT	NOV 98
C	CONDUCTOR SUPPORT BAR ADDED	AUG 98
B	HANDHOLE BOLT LENGTH REVISED	AUG 95
A	GENERAL REVISIONS	AUG 94

TYPE L SIGNAL POLE INSTALLATION DETAILS		SPECIFICATION DRAWING No.
Date	Approved	
30/09/93	E.L. (Signature on File) Chief Highway Engineer	SP635-2.2.3

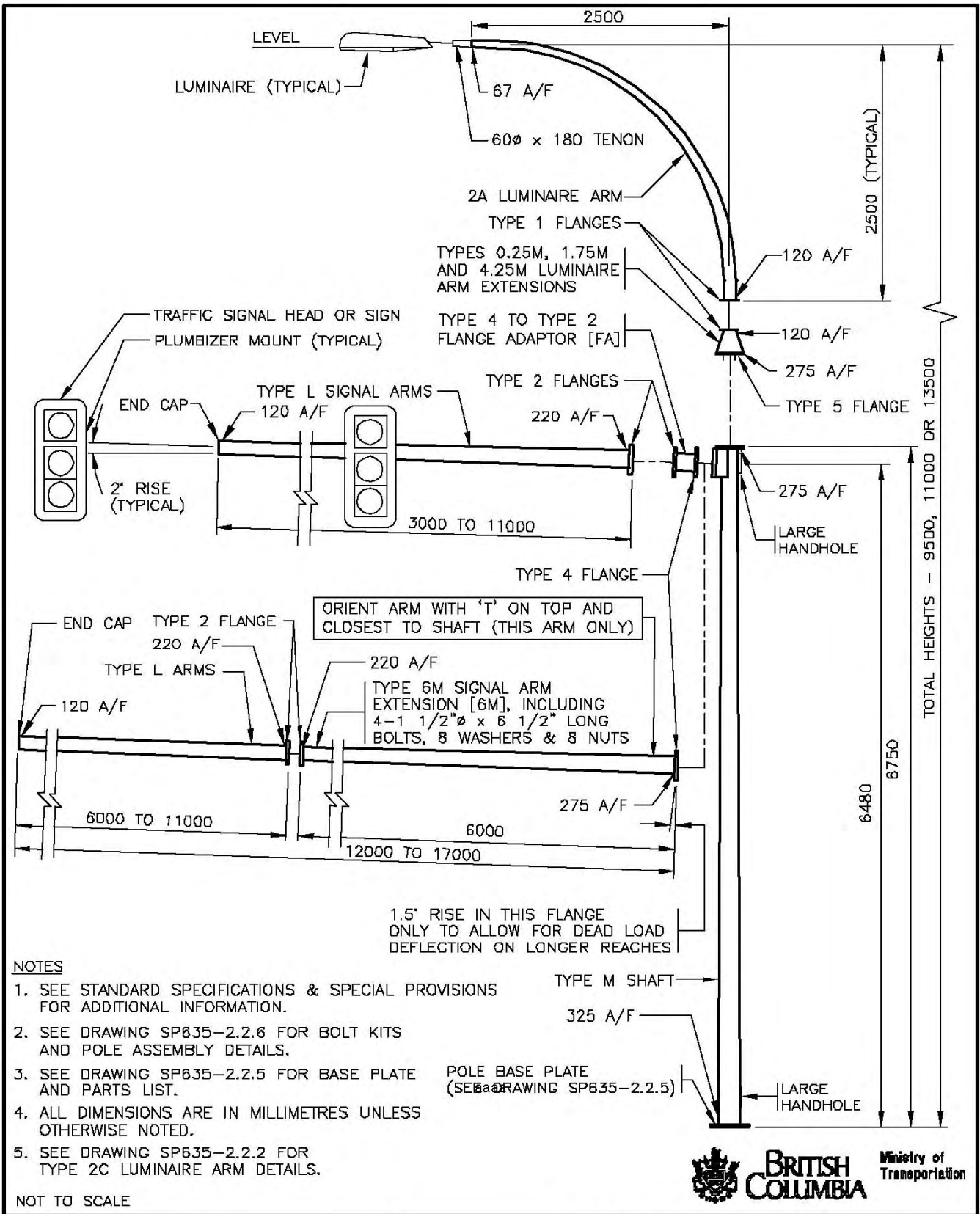

NOTES

1. SEE STANDARD SPECIFICATIONS & SPECIAL PROVISIONS FOR ADDITIONAL INFORMATION.
2. SEE DRAWING SP635-2.2.6 FOR BOLT KITS AND POLE ASSEMBLY DETAILS.
3. SEE DRAWING SP635-2.2.5 FOR BASE PLATE AND PARTS LIST.
4. ALL DIMENSIONS ARE IN MILLIMETRES UNLESS OTHERWISE NOTED.
5. SEE DRAWING SP635-2.2.2 FOR TYPE 2C LUMINAIRE ARM DETAILS.

NOT TO SCALE

No.	Revision	Date
F		
E		
D	SIGNAL HEAD MOUNTING ADDED	OCT 03
C	TYPE 6M EXTENSION ARM NOTE REVISED	AUG 96
B	6M ARM REVISED	AUG 95
A	GENERAL REVISIONS	AUG 94

**TYPE M SIGNAL POLE
INSTALLATION DETAILS**

Date: **30/09/93** Approved: **E.L. (Signature on File)**
Chief Highway Engineer

SPECIFICATION
DRAWING No.
SP635-2.2.4



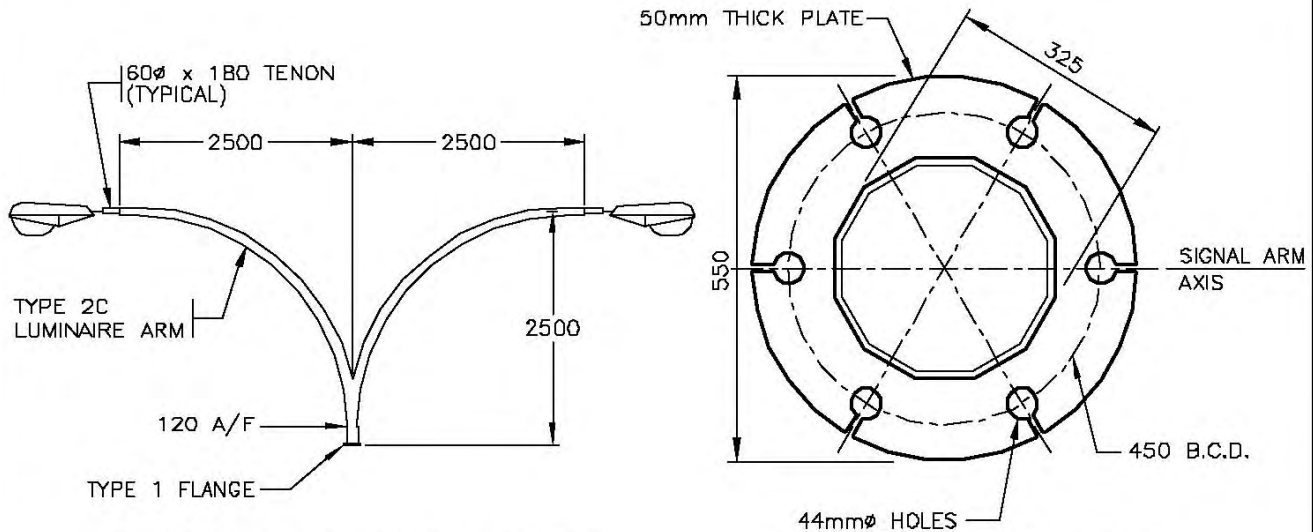

TYPE 2C LUMINAIRE ARM DETAILS

TYPE M POLE BASE PLATE

PARTS LIST FOR TYPE M SIGNAL POLE		
PART	MINISTRY STOCK NUMBER	MASS (kg)
TYPE [M] POLE SHAFT	SN2070	565
TYPE [6M] SIGNAL ARM EXTENSION - 6.0m	SN2071	360
TYPE [3L] SIGNAL ARM - 3.0m	SN2053	97
TYPE [4L] SIGNAL ARM - 4.0m	SN2054	118
TYPE [5L] SIGNAL ARM - 5.0m	SN2055	173
TYPE [6L] SIGNAL ARM - 6.0m	SN2056	201
TYPE [7L] SIGNAL ARM - 7.0m	SN2057	229
TYPE [8L] SIGNAL ARM - 8.0m	SN2058	257
TYPE [9L] SIGNAL ARM - 9.0m	SN2059	284
TYPE [10L] SIGNAL ARM - 10.0m	SN2060	377
TYPE [11L] SIGNAL ARM - 11.0m	SN2061	410
TYPE [4.25M] LUMINAIRE ARM EXTENSION - 4.25m	SN2072	115
TYPE [1.75M] LUMINAIRE ARM EXTENSION - 1.75m	SN2073	38
TYPE [0.25M] LUMINAIRE ARM EXTENSION - 0.25m	SN2074	14
TYPE [2A] LUMINAIRE ARM	SN1832	35
TYPE [2C] LUMINAIRE ARM	SN1833	65
TYPE 1 FLANGE COVER PLATE [1 FCP]	SN1367	1.5
TYPE 3 FLANGE COVER PLATE [3 FCP]	SN2084	4
TYPE 4 FLANGE COVER PLATE [4 FCP]	SN2085	8
TYPE 5 FLANGE COVER PLATE [5 FCP]	SN2086	4
TYPE 4 TO 2 FLANGE ADAPTOR [FA]	SN2080	75
POST TOP TENON [PTT]	SN1831	5

* [] I.D. LABEL ON POLE

NOT TO SCALE



No.	Revision	Date	TYPE M SIGNAL POLE INSTALLATION DETAILS		SPECIFICATION DRAWING No. SP635-2.2.5
F			Date	Approved	
E			30/09/93	E.L. (Signature on File)	
D				Chief Highway Engineer	
C					
B	HOLE SIZE REVISED & 2C ARM ADDED	AUG 95			
A	GENERAL REVISIONS	AUG 94			

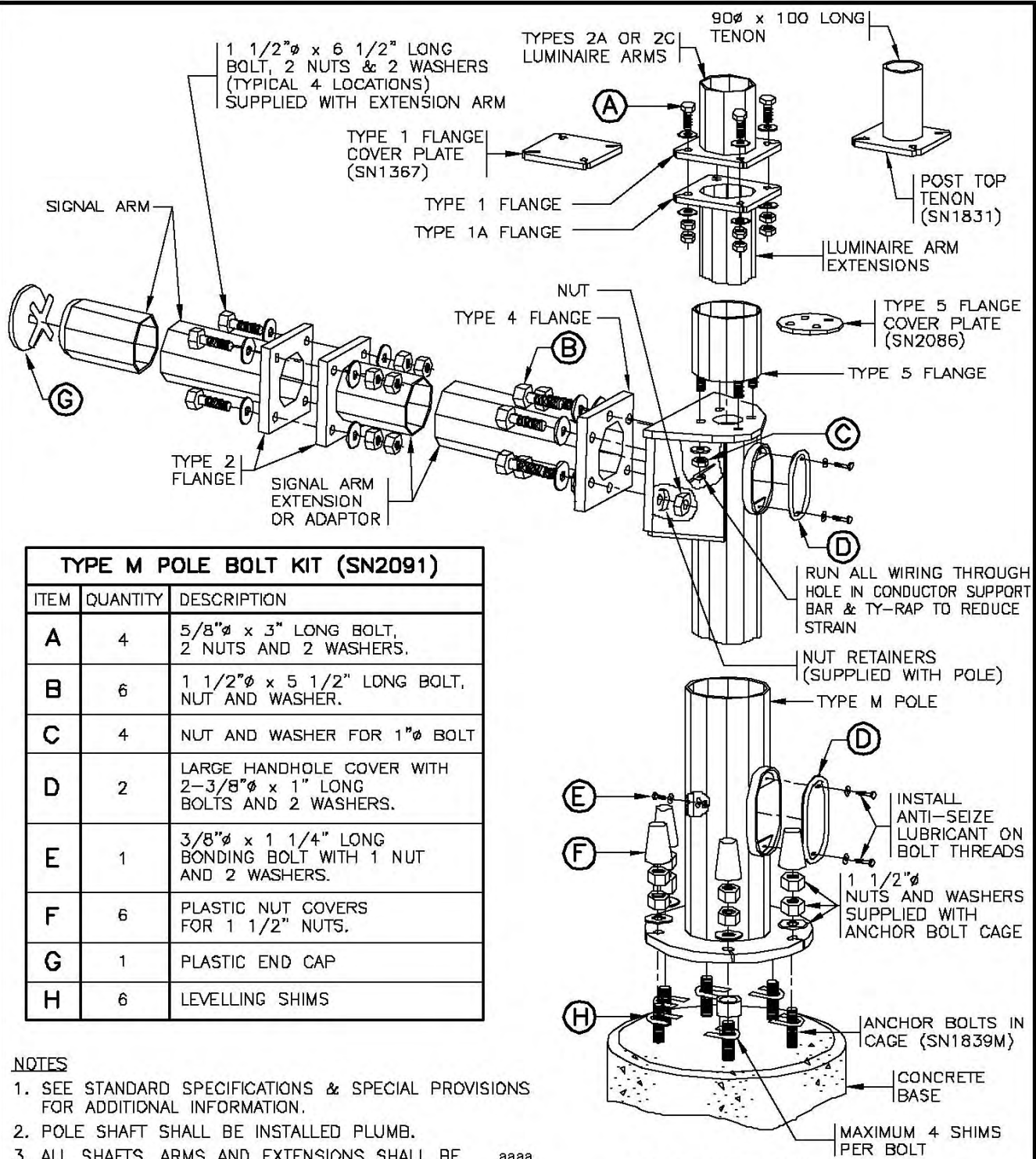

TYPE M POLE BOLT KIT (SN2091)		
ITEM	QUANTITY	DESCRIPTION
A	4	5/8" dia x 3" LONG BOLT, 2 NUTS AND 2 WASHERS.
B	6	1 1/2" dia x 5 1/2" LONG BOLT, NUT AND WASHER.
C	4	NUT AND WASHER FOR 1" dia BOLT
D	2	LARGE HANDHOLE COVER WITH 2-3/8" dia x 1" LONG BOLTS AND 2 WASHERS.
E	1	3/8" dia x 1 1/4" LONG BONDING BOLT WITH 1 NUT AND 2 WASHERS.
F	6	PLASTIC NUT COVERS FOR 1 1/2" NUTS.
G	1	PLASTIC END CAP
H	6	LEVELLING SHIMS

NOTES

- SEE STANDARD SPECIFICATIONS & SPECIAL PROVISIONS FOR ADDITIONAL INFORMATION.
- POLE SHAFT SHALL BE INSTALLED PLUMB.
- ALL SHAFTS, ARMS AND EXTENSIONS SHALL BE SUPPLIED WITH A GALVANIZED FINISH. aaaa
- APPLY GREASE TO ANCHOR BOLT THREADS.
- TOUCH UP ANY SCRATCHES IN GALVANIZED SURFACES WITH COLD GALVANIZING COMPOUND.

NOT TO SCALE

POLE ASSEMBLY DETAIL



No.	Revision	Date
E		
D	ANTI-SEIZING LUBRICANT NOTED ON HANDHOLE BOLT	NOV 98
C	BOLT KIT LIST REVISED & CONDUCTOR SUPPORT ADDED	AUG 96
B	HANDHOLE BOLT LENGTH REVISED	AUG 95
A	GENERAL REVISIONS	AUG 94

TYPE M SIGNAL POLE INSTALLATION DETAILS		
Date	Approved	SPECIFICATION DRAWING No.
30/09/93	E.L. (Signature on File) Chief Highway Engineer	SP635-2.2.6

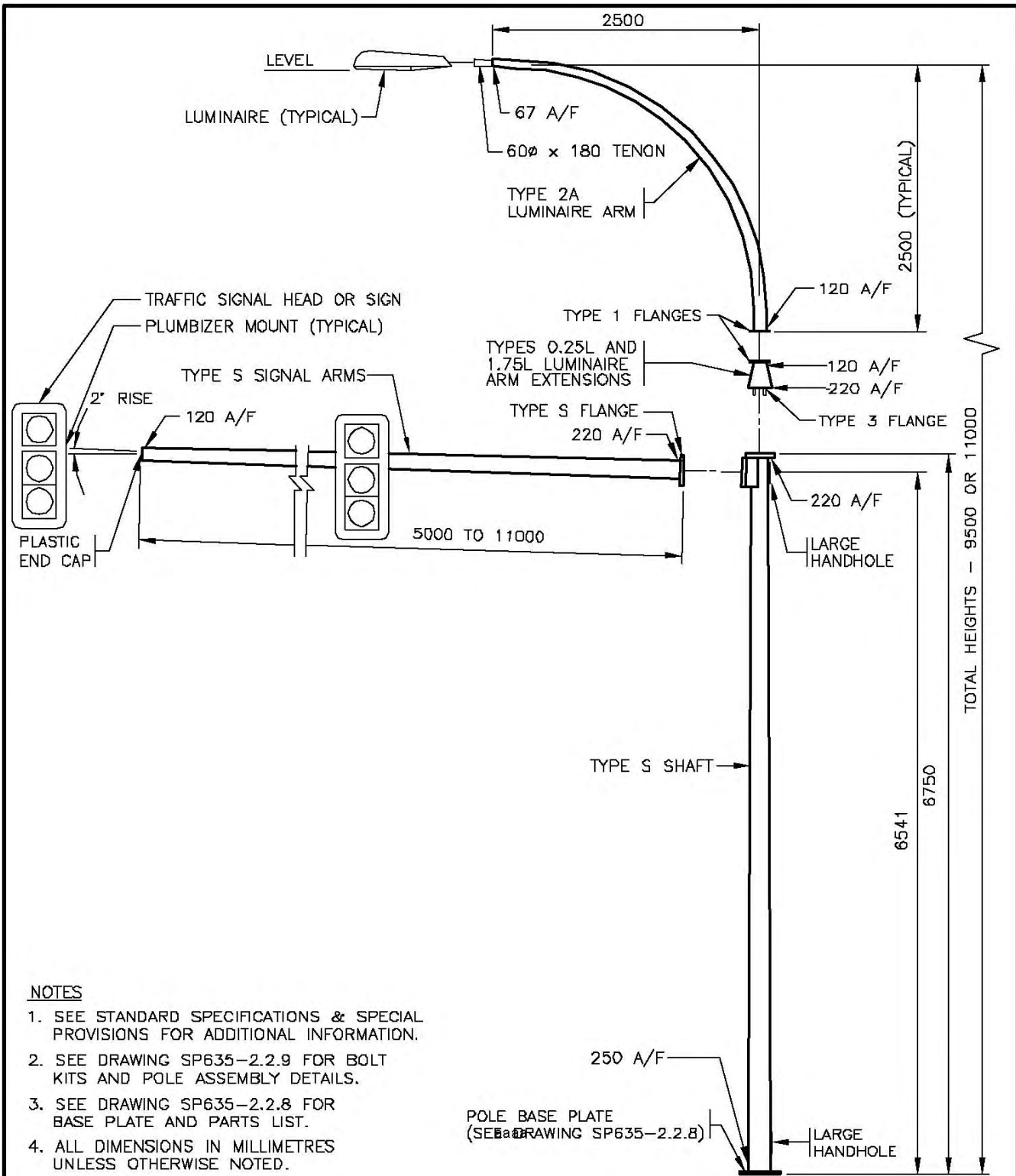

- NOTES**
1. SEE STANDARD SPECIFICATIONS & SPECIAL PROVISIONS FOR ADDITIONAL INFORMATION.
 2. SEE DRAWING SP635-2.2.9 FOR BOLT KITS AND POLE ASSEMBLY DETAILS.
 3. SEE DRAWING SP635-2.2.8 FOR BASE PLATE AND PARTS LIST.
 4. ALL DIMENSIONS IN MILLIMETRES UNLESS OTHERWISE NOTED.



NOT TO SCALE

No.	Revision	Date
E		
D		
C		
B		
A	NEW DRAWING—PREVIOUS DRAWING 2.2.7 TO MOVED TO 2.2.10	OCT 03

**TYPE S SIGNAL POLE
INSTALLATION DETAILS**

Date	Approved	SPECIFICATION DRAWING No.
14/11/03	D.N. (Signature on File) Chief Engineer	SP635-2.2.7

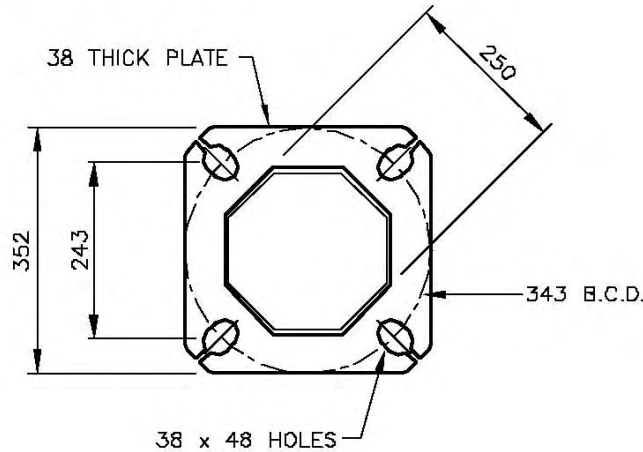

TYPE S POLE BASE PLATE

1:10

PARTS LIST FOR TYPE S SIGNAL POLE		
PART	MINISTRY STOCK NUMBER	MASS (kg)
TYPE [S] POLE SHAFT	SN3152	385
TYPE [5S] SIGNAL ARM - 5.0m	SN3150	104
TYPE [5.5S] SIGNAL ARM - 5.5m	SN3155	111
TYPE [6S] SIGNAL ARM - 6.0m	SN3160	118
TYPE [6.5S] SIGNAL ARM - 6.5m	SN3165	125
TYPE [7S] SIGNAL ARM - 7.0m	SN3170	132
TYPE [7.5S] SIGNAL ARM - 7.5m	SN3175	192
TYPE [8S] SIGNAL ARM - 8.0m	SN3180	204
TYPE [8.5S] SIGNAL ARM - 8.5m	SN3185	214
TYPE [9S] SIGNAL ARM - 9.0m	SN3190	224
TYPE [9.5S] SIGNAL ARM - 9.5m	SN3195	292
TYPE [10S] SIGNAL ARM - 10.0m	SN3100	306
TYPE [10.5S] SIGNAL ARM - 10.5m	SN3105	320
TYPE [11S] SIGNAL ARM - 11.0m	SN3110	340
TYPE [1.75L] LUMINAIRE ARM EXTENSION - 1.75m	SN2063	29
TYPE [0.25L] LUMINAIRE ARM EXTENSION - 0.25m	SN2064	10
TYPE [2A] LUMINAIRE ARM	SN1832	35
TYPE 1 FLANGE COVER PLATE [1 FCP]	SN1367	1.5
TYPE S FLANGE COVER PLATE [S FCP]	SN1368	3
TYPE 3 FLANGE COVER PLATE [3 FCP]	SN2084	4
POST TOP TENON [PTT]	SN1831	5

* [] I.D. LABEL ON POLE

aaaa



NOT TO SCALE

No.	Revision	Date	TYPE S SIGNAL POLE INSTALLATION DETAILS	
F			Date	Approved
E			14/11/03	D.N. (Signature on File)
D				Chief Engineer
C				SPECIFICATION DRAWING No.
B				SP635-2.2.8
A				

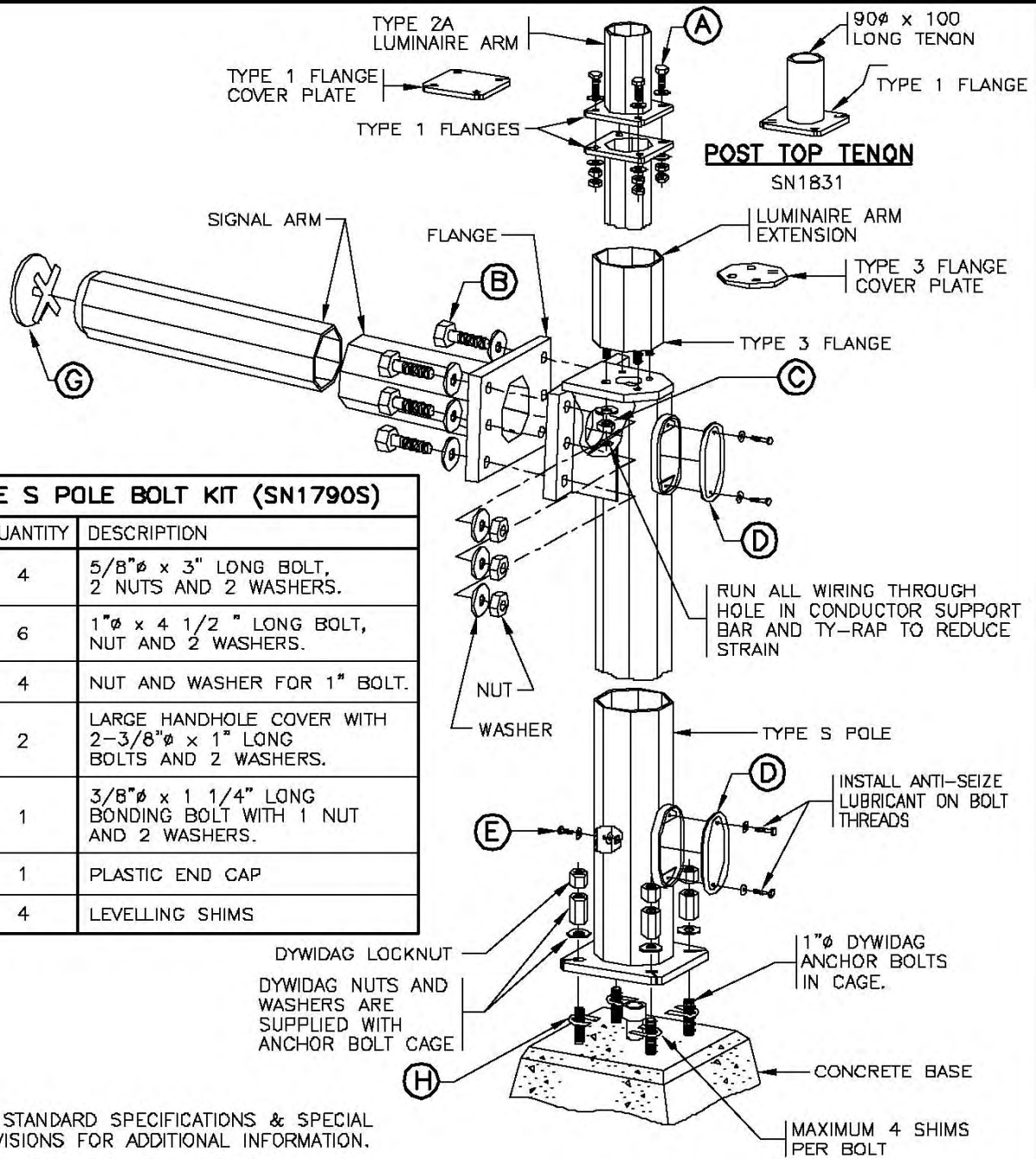

TYPE S POLE BOLT KIT (SN1790S)		
ITEM	QUANTITY	DESCRIPTION
A	4	5/8"φ x 3" LONG BOLT, 2 NUTS AND 2 WASHERS.
B	6	1"φ x 4 1/2" LONG BOLT, NUT AND 2 WASHERS.
C	4	NUT AND WASHER FOR 1" BOLT.
D	2	LARGE HANDHOLE COVER WITH 2-3/8"φ x 1" LONG BOLTS AND 2 WASHERS.
E	1	3/8"φ x 1 1/4" LONG BONDING BOLT WITH 1 NUT AND 2 WASHERS.
G	1	PLASTIC END CAP
H	4	LEVELLING SHIMS

- NOTES**
1. SEE STANDARD SPECIFICATIONS & SPECIAL PROVISIONS FOR ADDITIONAL INFORMATION.
 2. SHAFTS TO BE INSTALLED PLUMB.
 3. ALL SHAFTS, ARMS AND EXTENSIONS TO BE SUPPLIED WITH A GALVANIZED FINISH.
 4. APPLY GREASE TO ANCHOR BOLT THREADS.
 5. TOUCH UP ANY SCRATCHES IN GALVANIZED SURFACES WITH COLD GALVANIZING COMPOUND.

POLE ASSEMBLY DETAIL



NOT TO SCALE

No.	Revision	Date
F		
E		
D		
C		
B		
A		

TYPE S SIGNAL POLE INSTALLATION DETAILS		Date	Approved	SPECIFICATION DRAWING No.
		14/11/03	D.N. (Signature on File) Chief Engineer	SP635-2.2.9

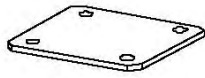

**TYPE 1 FLANGE
COVER PLATE**
SN1367

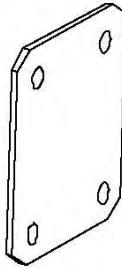

**TYPE 2 FLANGE
COVER PLATE**
SN2083

4-1"φ x 2 1/2" LONG
BOLTS AND WASHERS
(PART OF SN2084)

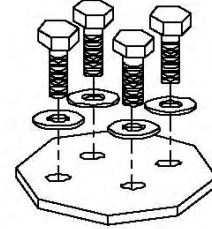

**TYPE 3 FLANGE
COVER PLATE**
SN2084

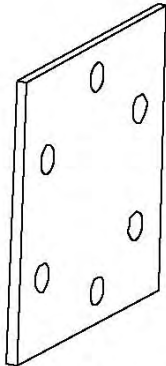

**TYPE 4 FLANGE
COVER PLATE**
SN2085

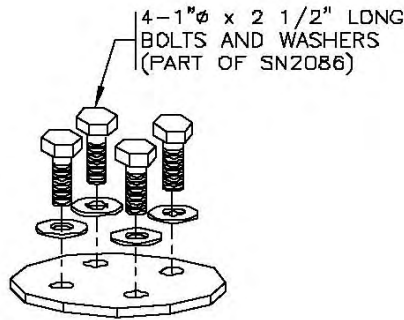

**TYPE 5 FLANGE
COVER PLATE**
SN2086

4-1"φ x 2 1/2" LONG
BOLTS AND WASHERS
(PART OF SN2086)

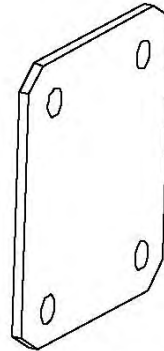

**TYPE 8 FLANGE
COVER PLATE**
SN2089

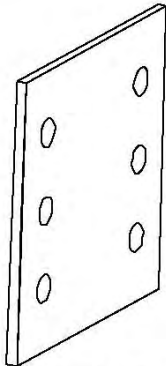

**TYPE S FLANGE
COVER PLATE**
SN1368

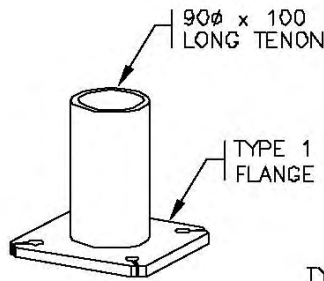

**POST TOP
TENON**
SN1831

90φ x 100
LONG TENON

TYPE 1
FLANGE

TYPE 2 FLANGE

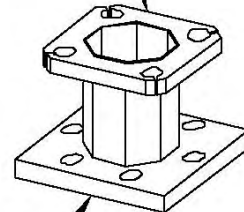

TYPE 4 FLANGE

**TYPE 4 TO TYPE 2
FLANGE ADAPTOR**
SN2080

NOTES

1. SEE STANDARD SPECIFICATIONS & SPECIAL PROVISIONS FOR ADDITIONAL INFORMATION.

NOT TO SCALE



No.	Revision	Date
F		
E		
D		
C		
B		
A	TYPE S FLANGE COVER PLATE ADDED	OCT 03

SIGNAL POLE ACCESSORIES		
Date	Approved	SPECIFICATION DRAWING No.
14/11/03	D.N. (Signature on File) Chief Engineer	SP635-2.2.10

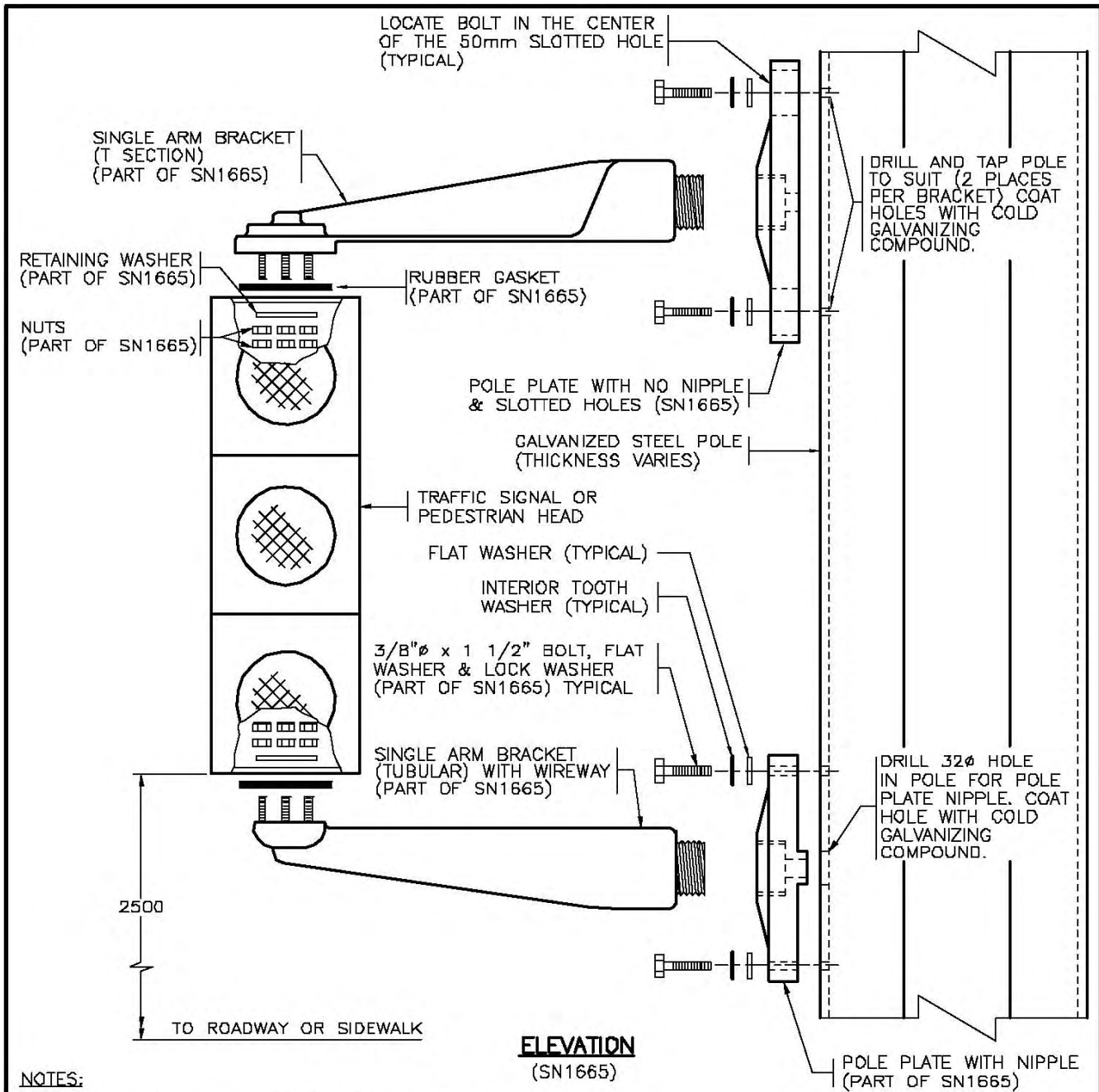

NOTES:

1. SEE STANDARD SPECIFICATIONS & SPECIAL PROVISIONS FOR ADDITIONAL INFORMATION
2. AIM SIGNAL HEADS IN ACCORDANCE WITH DRAWING SP635-2.3.11
3. 'SN' DENOTES MINISTRY STOCK NUMBER.
4. WHERE 3 OR MORE SIDE MOUNT SIGNAL HEADS ARE REQUIRED ON A POLE LOCATE THE 3rd AND 4th PEDESTRIAN HEAD ARM BRACKETS WITH WIREWAY AND POLE PLATE WITH THE NIPPLE TO THE TOP OF THE HEAD TO AVOID EXCESSIVE DRILLING OF THE POLE IN ONE AREA.

NOT TO SCALE



No.	Revision	Date	SIGNAL AND PEDESTRIAN HEAD SIDE MOUNT INSTALLATION DETAILS	
F				
E				
D	NOTE 2 REVISED	OCT 03	Date	Approved
C	NYLOCK NUTS REMOVED. DOUBLE NUTS ADDED	AUG 99	30/09/93 E.L. (Signature on File) Chief Highway Engineer	SPECIFICATION DRAWING No. SP635-2.3.1
B	SIGN MOUNTING HEIGHT ADDED	AUG 95		
A	GENERAL REVISIONS	AUG 94		

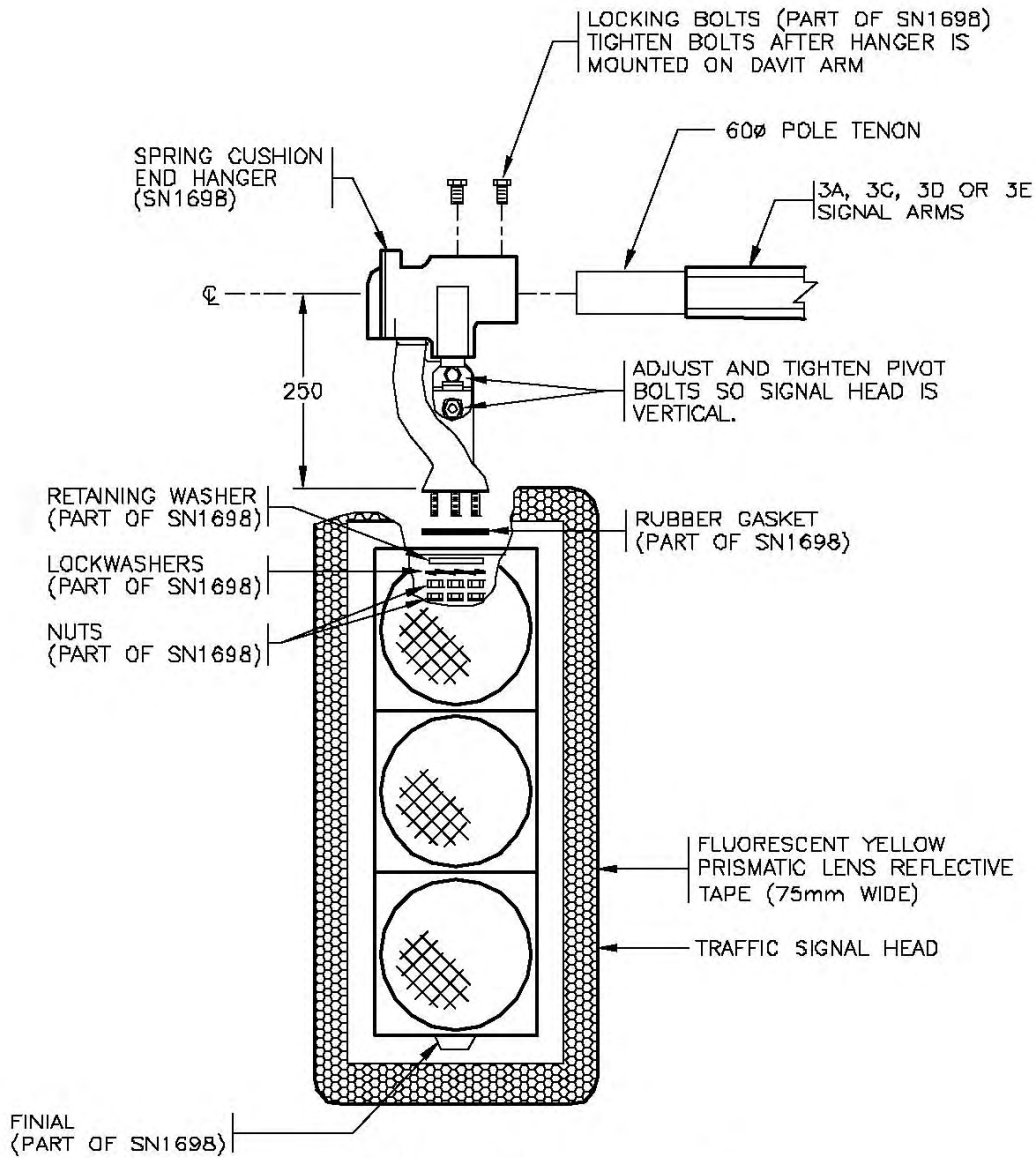

ELEVATION

FOR REFERENCE ONLY
 USE END PLUMBIZER FOR
 INSTALLATIONS UNLESS
 OTHERWISE NOTED

NOTES

1. SEE STANDARD SPECIFICATIONS & SPECIAL PROVISIONS FOR ADDITIONAL INFORMATION.
2. AIM SIGNAL HEADS IN ACCORDANCE WITH DRAWING SP635-2.3.11
3. 'SN' DENOTES MINISTRY STOCK NUMBER.

NOT TO SCALE



No.	Revision	Date
F	NOTE 2 REVISED	OCT 03
E	REFLECTIVE TAPE ADDED	NOV 01
D	NYLOCK NUTS REMOVED. DOUBLE NUTS ADDED	AUG 99
C	NEW DRAWING	OCT 97
B	SIGNAL HEAD SIZE CHANGED	AUG 95
A	GENERAL REVISIONS	AUG 94

OVERHEAD SPRING CUSHION END SIGNAL HEAD HANGER INSTALLATION DETAILS		DATE	APPROVED	SPECIFICATION DRAWING No.
		30/09/93	E.L. (Signature on File) Chief Highway Engineer	SP635-2.3.2

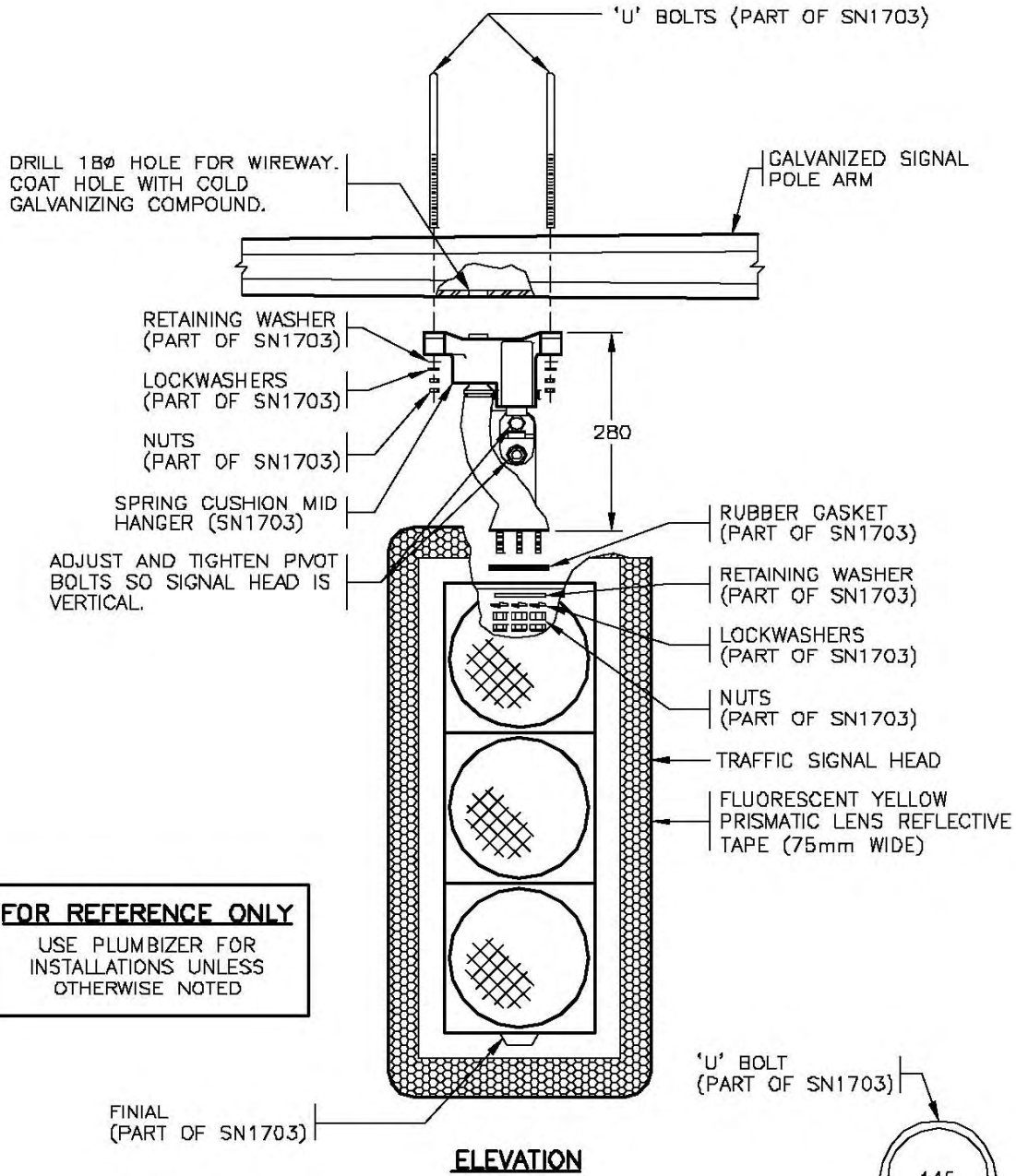

FOR REFERENCE ONLY
 USE PLUMBIZER FOR
 INSTALLATIONS UNLESS
 OTHERWISE NOTED

NOTES

1. SEE STANDARD SPECIFICATIONS & SPECIAL PROVISIONS FOR ADDITIONAL INFORMATION.
2. AIM SIGNAL HEADS IN ACCORDANCE WITH DRAWING SP635-2.3.11
3. 'SN' DENOTES MINISTRY STOCK NUMBER.

NOT TO SCALE



No.	Revision	Date
F	NOTE 2 REVISED	OCT 03
E	REFLECTIVE TAPE ADDED	NOV 01
D	NYLOCK NUTS REMOVED. DOUBLE NUTS ADDED	AUG 99
C	NEW DRAWING NUMBER	OCT 97
B	SIGNAL HEAD SIZE CHANGED	AUG 95
A	GENERAL REVISIONS	AUG 94

**OVERHEAD SPRING CUSHION MID HANGER
 SIGNAL HEAD INSTALLATION DETAILS**

Date: **30/09/93** Approved: **E.L. (Signature on File)**
 Chief Highway Engineer

SPECIFICATION
 DRAWING No.
SP635-2.3.3

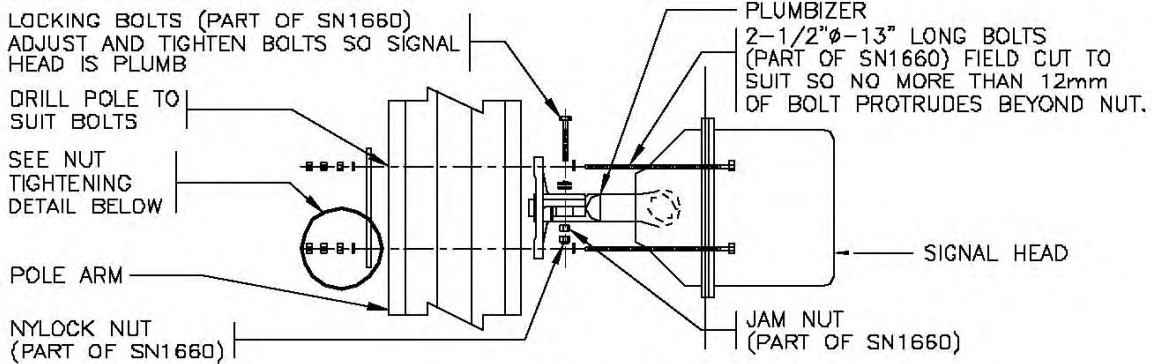

TOP VIEW

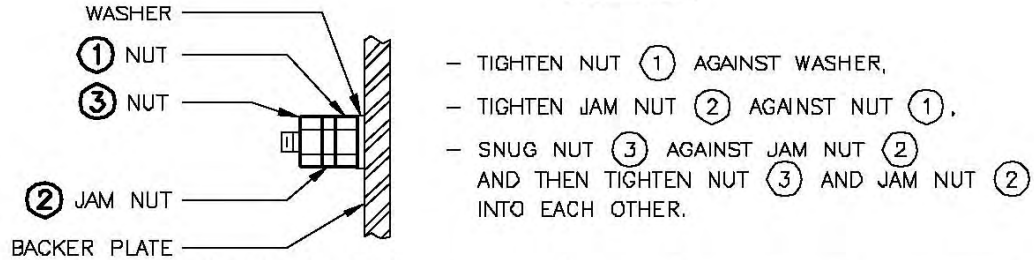

NUT TIGHTENING DETAIL

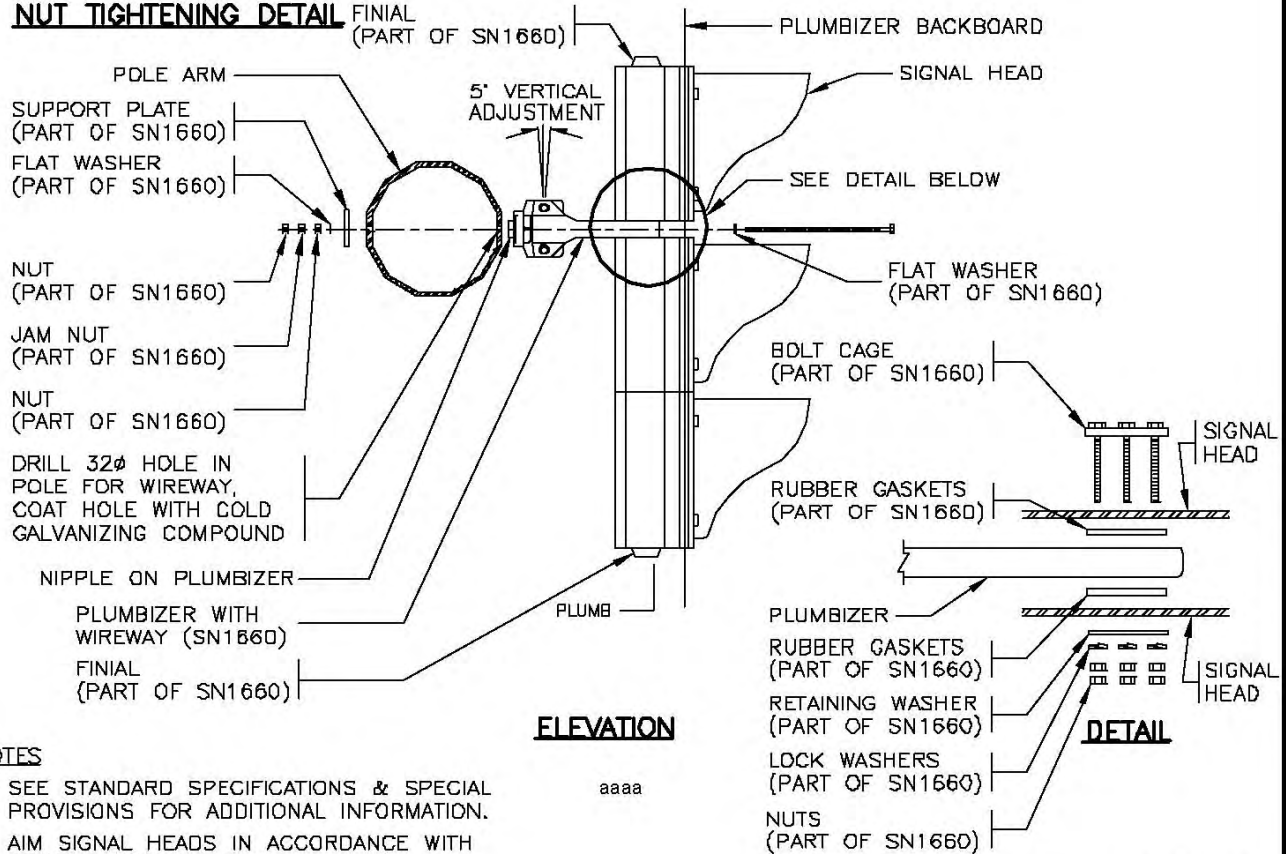

ELEVATION

DETAIL

NOTES

1. SEE STANDARD SPECIFICATIONS & SPECIAL PROVISIONS FOR ADDITIONAL INFORMATION.
2. AIM SIGNAL HEADS IN ACCORDANCE WITH DRAWING SP635-2.3.11
3. 'SN' DENOTES MINISTRY STOCK NUMBER.

NOT TO SCALE



No.	Revision	Date
F	NOTE 2 REVISED	OCT 03
E	DETAILS FROM SP635-2.3.5 ADDED	NOV 01
D	NYLOCK NUTS REMOVED, DOUBLE NUTS ADDED	AUG 99
C	NEW DRAWING NUMBER	OCT 97
B	CONNECTION BOLTS REVISED	AUG 95
A	GENERAL REVISIONS	AUG 94

SIGNAL HEAD PLUMBIZER
INSTALLATION DETAILS

Date **30/09/93** Approved **E.L. (Signature on File)**
Chief Highway Engineer

SPECIFICATION
DRAWING No.
SP635-2.3.4

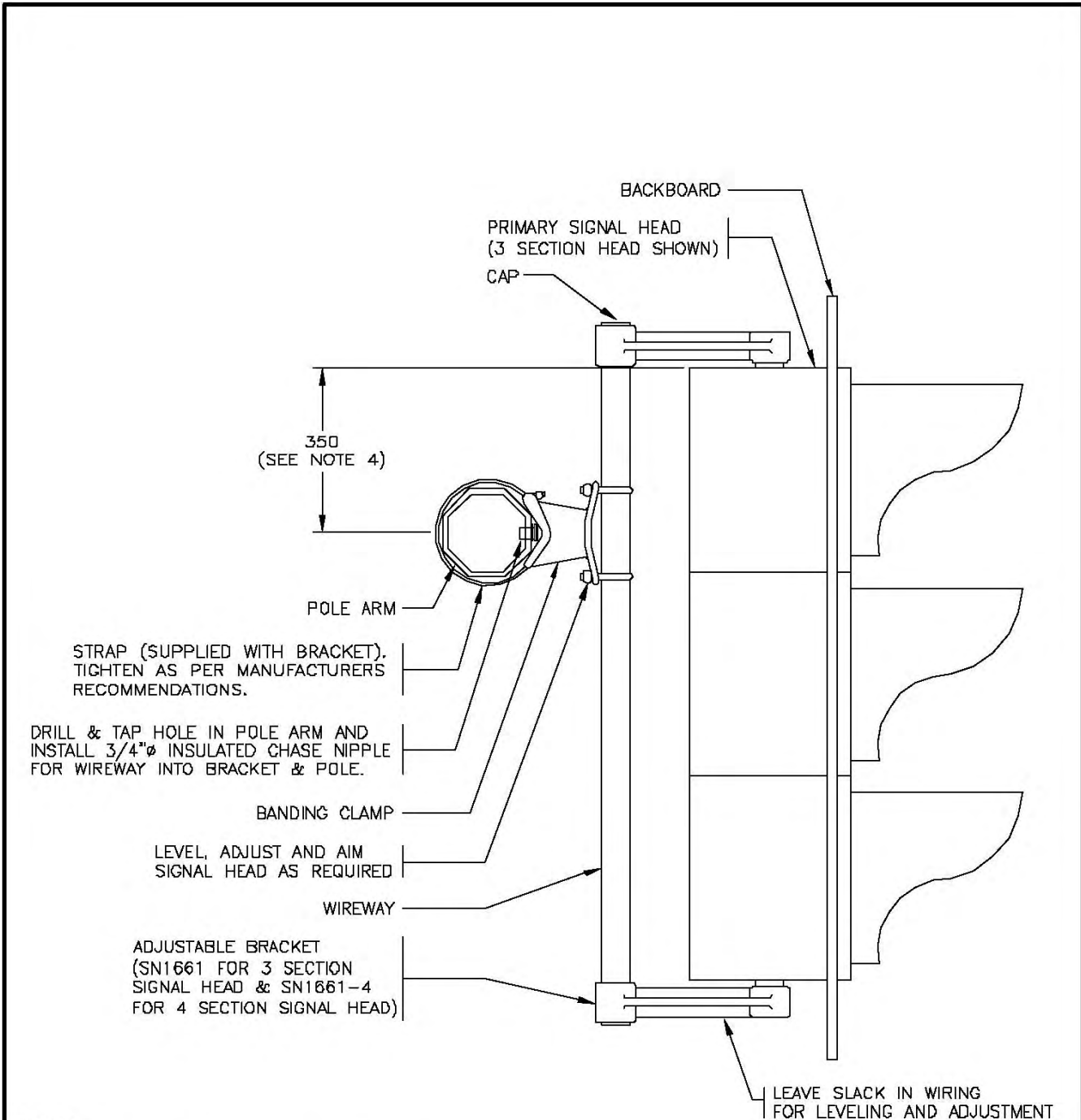

STRAP (SUPPLIED WITH BRACKET).
TIGHTEN AS PER MANUFACTURERS
RECOMMENDATIONS.

DRILL & TAP HOLE IN POLE ARM AND
INSTALL 3/4"Ø INSULATED CHASE NIPPLE
FOR WIREWAY INTO BRACKET & POLE.

LEVEL, ADJUST AND AIM
SIGNAL HEAD AS REQUIRED

ADJUSTABLE BRACKET
(SN1661 FOR 3 SECTION
SIGNAL HEAD & SN1661-4
FOR 4 SECTION SIGNAL HEAD)

LEAVE SLACK IN WIRING
FOR LEVELING AND ADJUSTMENT

NOTES

1. SEE STANDARD SPECIFICATIONS & SPECIAL PROVISIONS FOR ADDITIONAL INFORMATION.
2. AIM SIGNAL HEADS IN ACCORDANCE WITH DRAWING SP635-2.3.11
3. 'SN' DENOTES MINISTRY STOCK NUMBER.
4. ADJUST SIGNAL HEAD MOUNTING HEIGHT AS DIRECTED TO AVOID CONFLICTS.

aaaa

NOT TO SCALE



No.	Revision	Date
F		
E		
D		
C		
B		
A	NOTE 2 REVISED	OCT 03

SIGNAL HEAD ADJUSTABLE BRACKET DETAILS

Date	Approved	SPECIFICATION DRAWING No.
2001/12/13	D.N. (Signature on File)	SP635-2.3.5
Chief Highway Engineer		

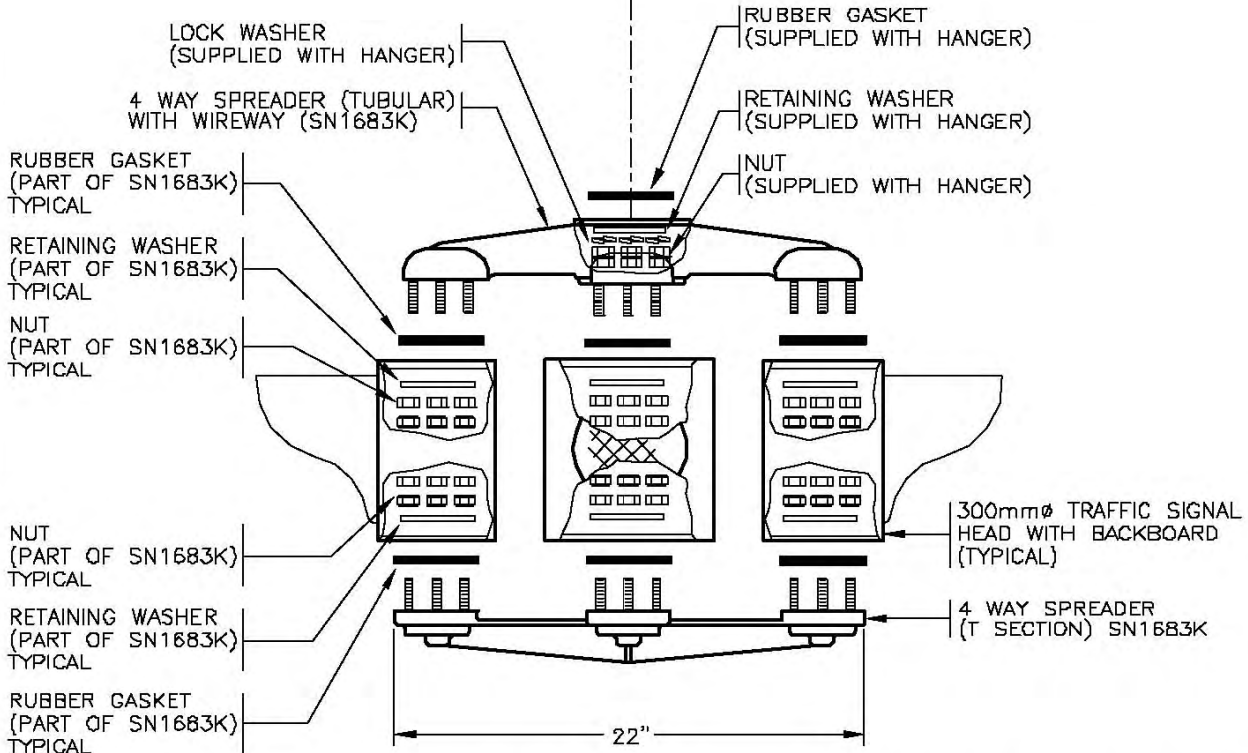
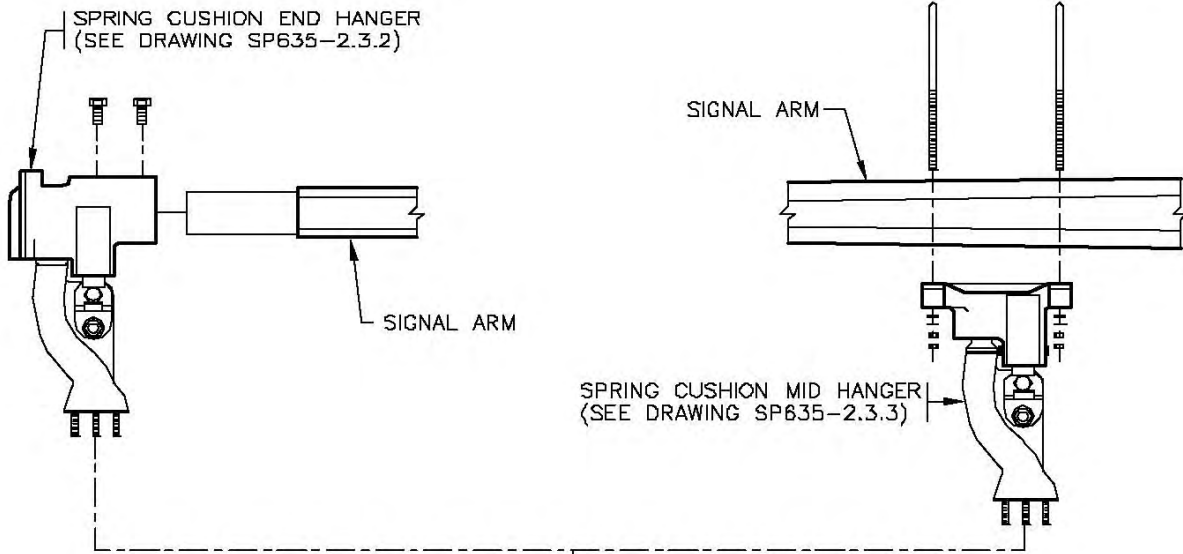

NOTES

1. SEE STANDARD SPECIFICATIONS & SPECIAL PROVISIONS FOR ADDITIONAL INFORMATION.
2. AIM SIGNAL HEADS IN ACCORDANCE WITH DRAWING SP635-2.3.11
3. 'SN' DENOTES MINISTRY STOCK NUMBER.

NOT TO SCALE

MOUNTING FOR 2, 3 AND 4 WAY SPREADERS IDENTICAL



No.	Revision	Date
F	NOTE 2 REVISED	OCT 03
E	NYLOCK NUTS REMOVED. DOUBLE NUTS ADDED	AUG 99
D	NEW DRAWING NUMBER	OCT 97
C	STOCK NUMBERS REVISED	AUG 96
B	DRAWING NUMBER REVISED	AUG 95
A	GENERAL REVISIONS	AUG 94

FOUR-WAY OVERHEAD FLASHING SIGNAL HEAD INSTALLATION DETAILS		
Date	Approved	SPECIFICATION DRAWING No.
30/09/93	E.L. (Signature on File) Chief Highway Engineer	SP635-2.3.6

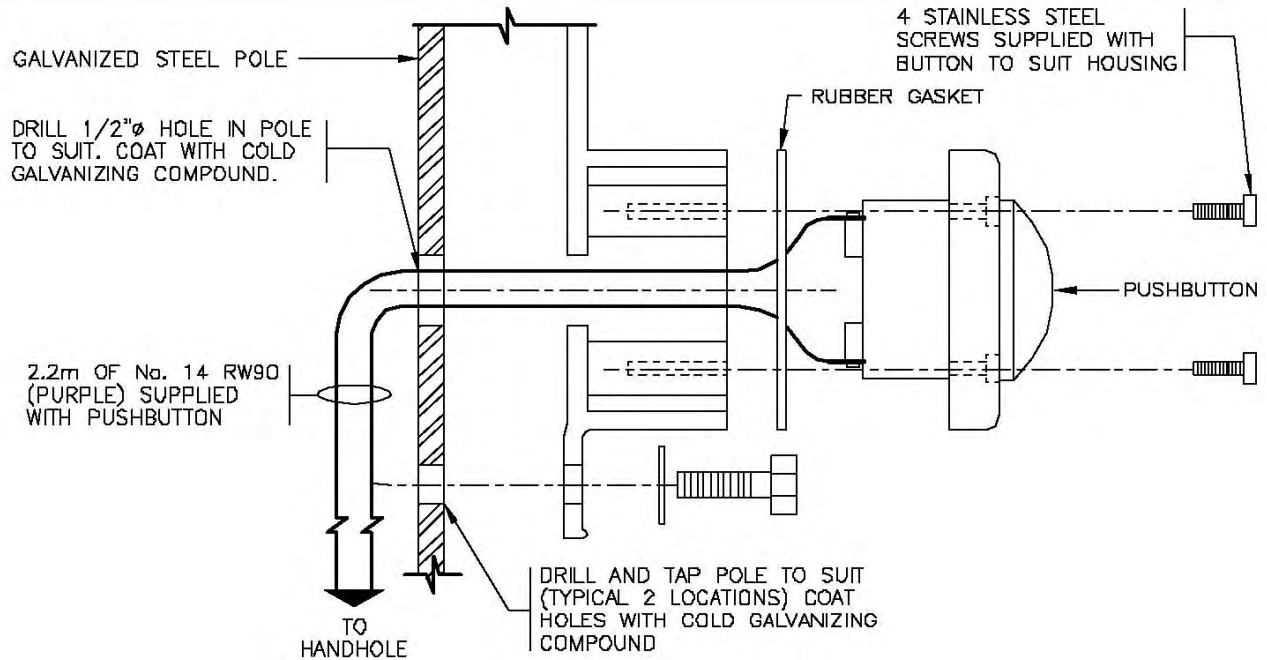

SIDE VIEW

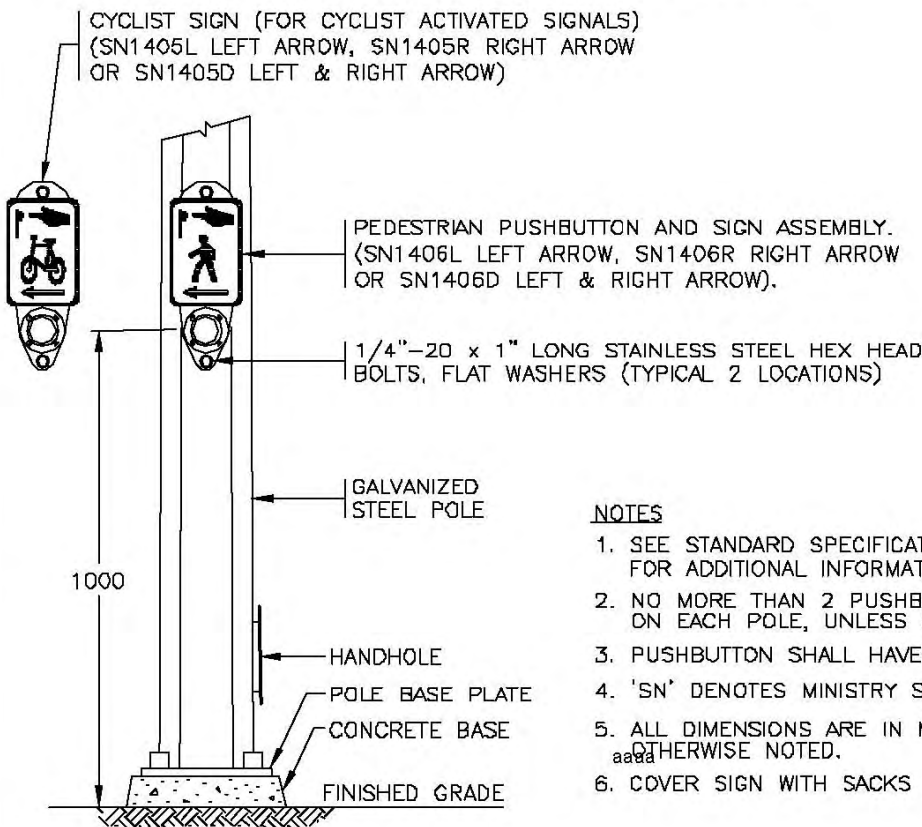

ELEVATION

NOTES

1. SEE STANDARD SPECIFICATIONS & SPECIAL PROVISIONS FOR ADDITIONAL INFORMATION.
2. NO MORE THAN 2 PUSHBUTTONS SHALL BE INSTALLED ON EACH POLE, UNLESS OTHERWISE NOTED.
3. PUSHBUTTON SHALL HAVE NORMALLY OPEN CONTACTS.
4. 'SN' DENOTES MINISTRY STOCK NUMBER.
5. ALL DIMENSIONS ARE IN MILLIMETRES UNLESS OTHERWISE NOTED.
6. COVER SIGN WITH SACKS UNTIL SIGNAL IS OPERATIONAL.



NOT TO SCALE

No.	Revision	Date
F		
E		
D	NEW PUSHBUTTON & SIGN	OCT 03
C	NEW DRAWING NUMBER	OCT 97
B	BOLTS AND DWG. No. REVISED	AUG 95
A	GENERAL REVISIONS	AUG 94

PEDESTRIAN PUSHBUTTON WITH INTEGRAL SIGN INSTALLATION DETAILS

Date Approved
30/09/93 E.L. (Signature on File)
 Chief Highway Engineer

SPECIFICATION DRAWING No.
SP635-2.3.7

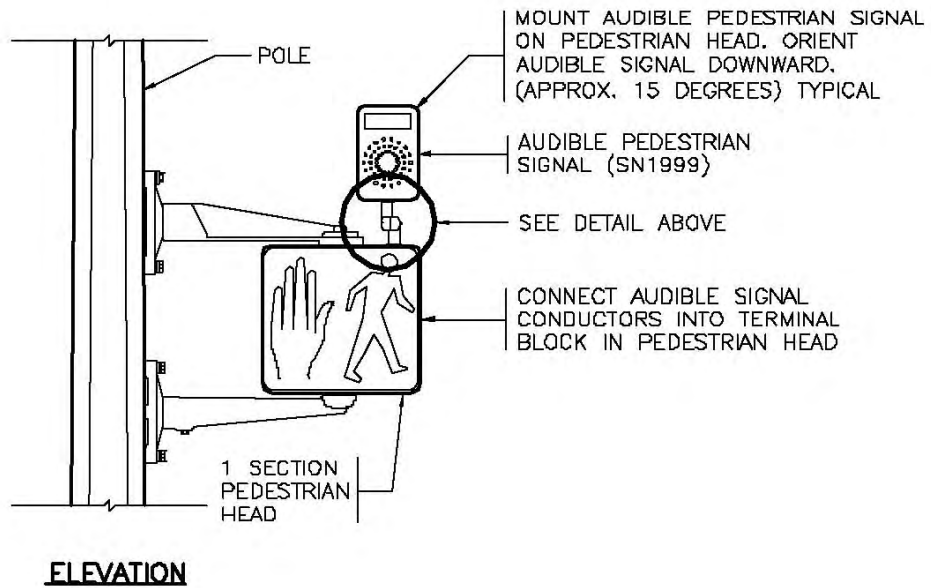
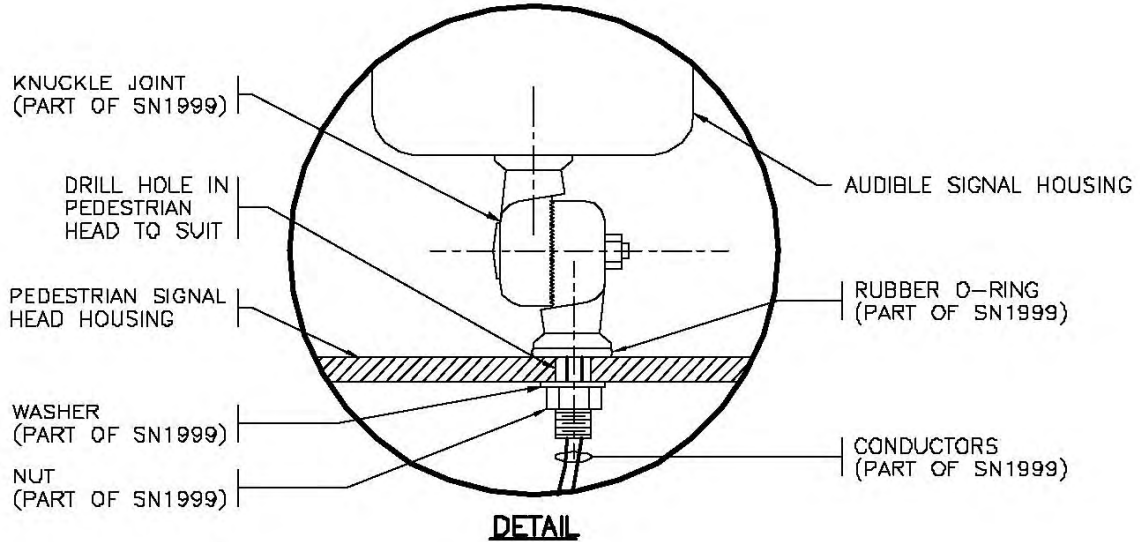

NOTES

1. SEE STANDARD SPECIFICATIONS & SPECIAL PROVISIONS FOR ADDITIONAL INFORMATION.
2. AIM, ADJUST AND CONNECT AUDIBLE SIGNAL AS PER MANUFACTURERS INSTRUCTIONS TO THE SATISFACTION OF THE MINISTRY REPRESENTATIVE.
3. AUDIBLE SIGNAL SHALL 'CHIRP-CHIRP' FOR EAST TO WEST CROSSINGS AND 'CUCKOO' FOR NORTH TO SOUTH CROSSINGS. AT INTERSECTIONS WHERE NORTH/SOUTH AND EAST/WEST ARE NOT EASILY DEFINED CONTACT THE MINISTRY REPRESENTATIVE.
4. 'SN' DENOTES MINISTRY STOCK NUMBER.



NOT TO SCALE

No.	Revision	Date
F		
E	GENERAL REVISIONS	OCT 03
D	ALTERNATE SINGLE SECTION LED PED. HEAD ADDED	NOV 01
C	NOTE 3 REVISED	NOV 98
B	NEW DRAWING NUMBER	OCT 97
A	N/S CROSSING SOUND & DWG. No. REVISED	AUG 95

AUDIBLE SIGNAL INSTALLATION DETAILS		
Date	Approved	SPECIFICATION DRAWING No.
21/11/94	E.L. (Signature on File) Chief Highway Engineer	SP635-2.3.8

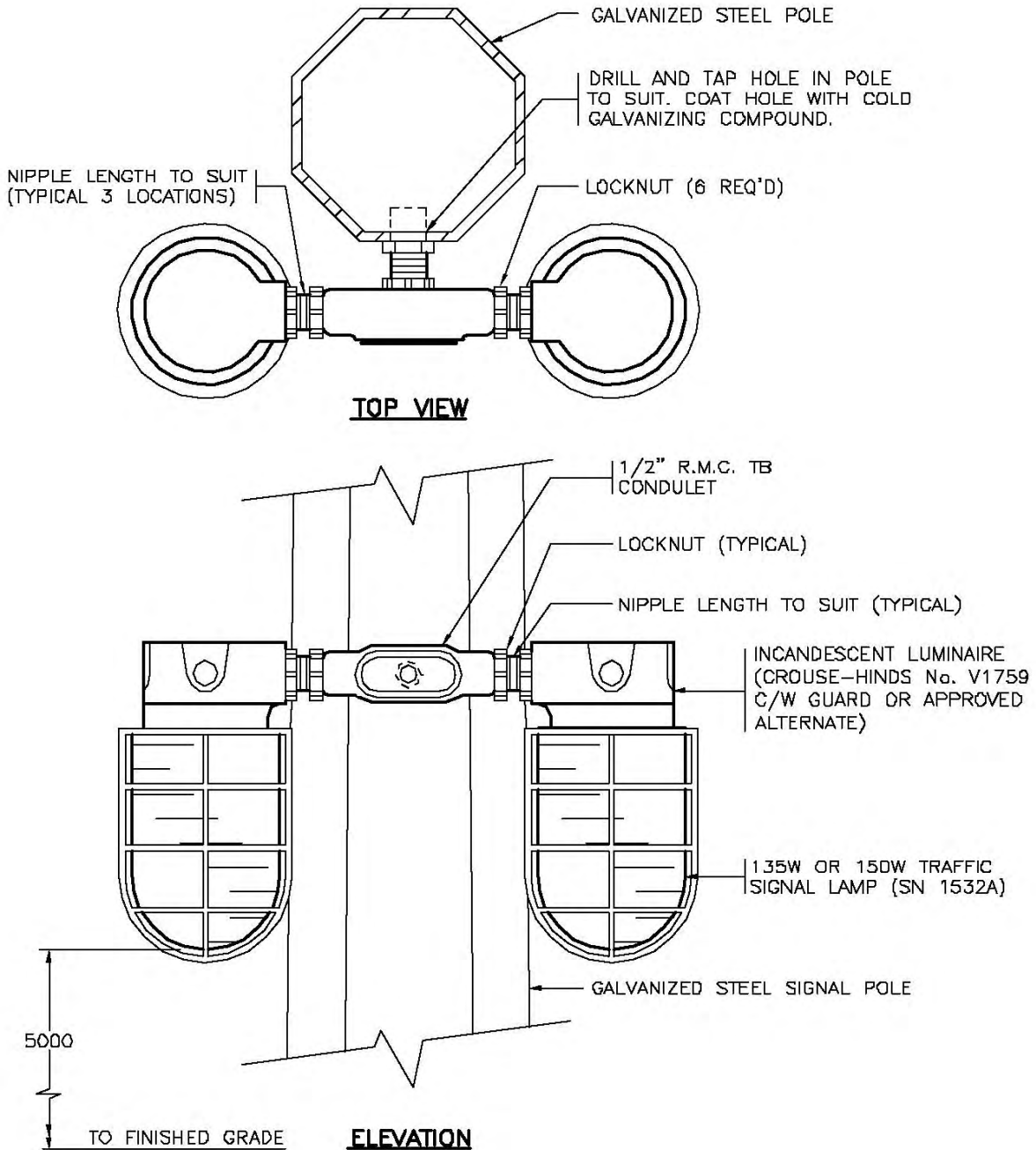

NOTES

1. SEE STANDARD SPECIFICATIONS & SPECIAL PROVISIONS FOR ADDITIONAL INFORMATION.
2. ALL NUTS, WASHERS, NIPPLES & BUSHINGS SHALL BE GALVANIZED.
3. ORIENT FIRE LIGHTS ON POLE SO VISIBLE BY FIRE TRUCK DRIVER.
4. *SN* DENOTES MINISTRY STOCK NUMBER.

aaaa

NOT TO SCALE



No.	Revision	Date
F		
E		
D		
C	LUMINAIRE MODEL No. UPDATED	OCT 03
B	NEW DRAWING NUMBER	OCT 97
A	DRAWING NUMBER REVISED	AUG 95

FIRE SIGNAL INDICATION LIGHT INSTALLATION DETAIL		
Date	Approved	SPECIFICATION DRAWING No.
18/11/94	E.L. (Signature on File) Chief Highway Engineer	SP635-2.3.9

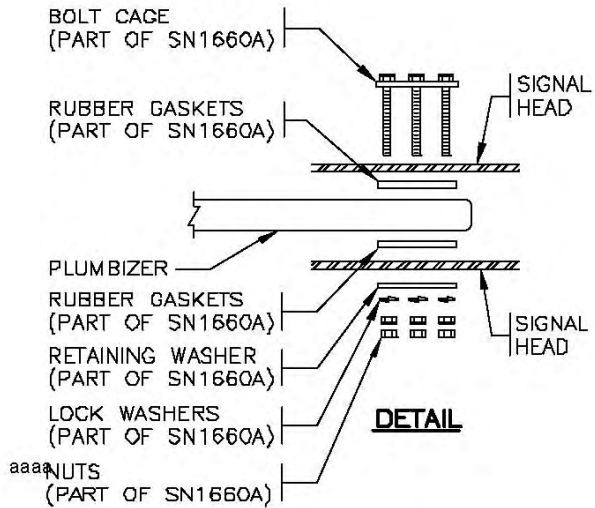
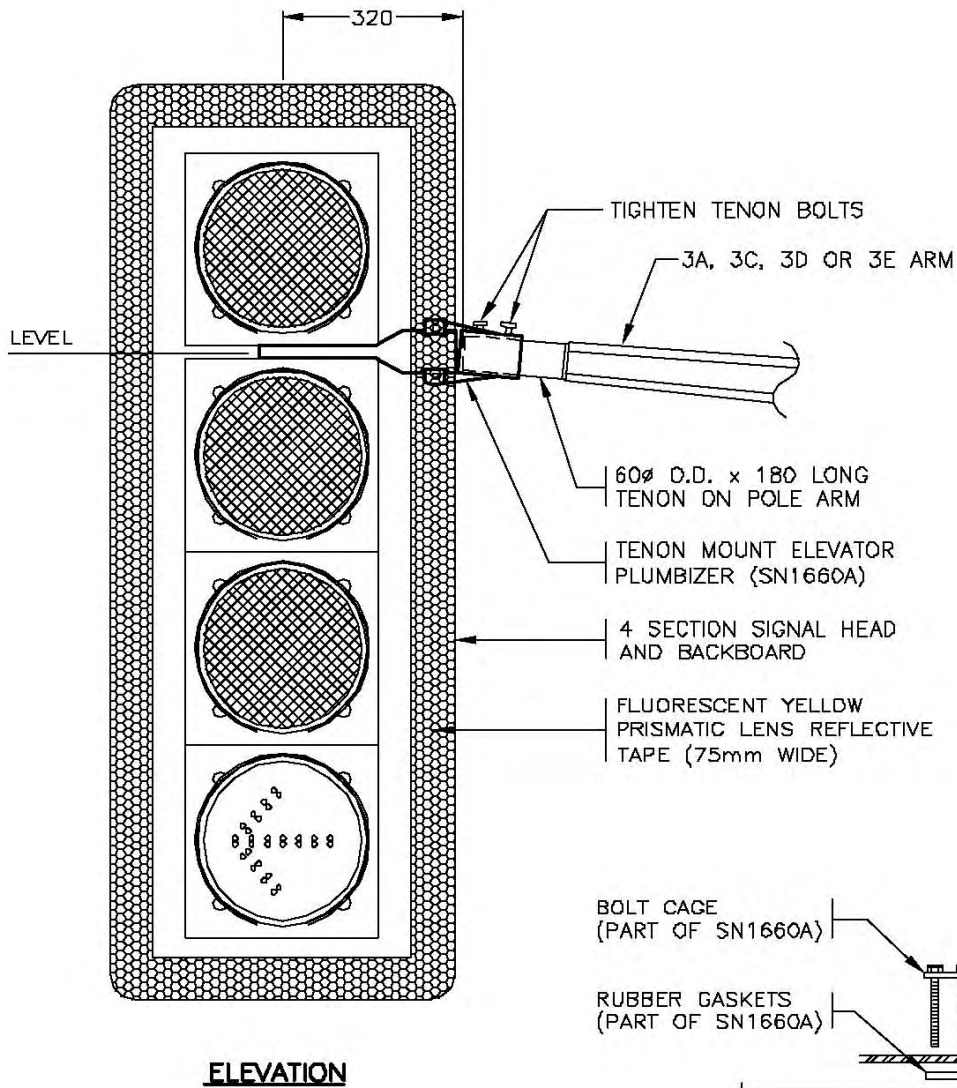

NOTES

1. SEE STANDARD SPECIFICATIONS & SPECIAL PROVISIONS FOR ADDITIONAL INFORMATION.
2. AIM SIGNAL HEADS IN ACCORDANCE WITH DRAWING SP635-2.3.11.
3. 'SN' DENOTES MINISTRY STOCK NUMBER.

NOT TO SCALE



No.	Revision	Date
F		
E		
D		
C		
B		
A		

**SIGNAL HEAD PLUMBIZER
INSTALLATION DETAILS (FOR TYPE 3 SIGNAL ARMS)**

Date **14/11/03** Approved **D.N. (Signature on File)**
Chief Engineer

SPECIFICATION
DRAWING No.
SP635-2.3.10

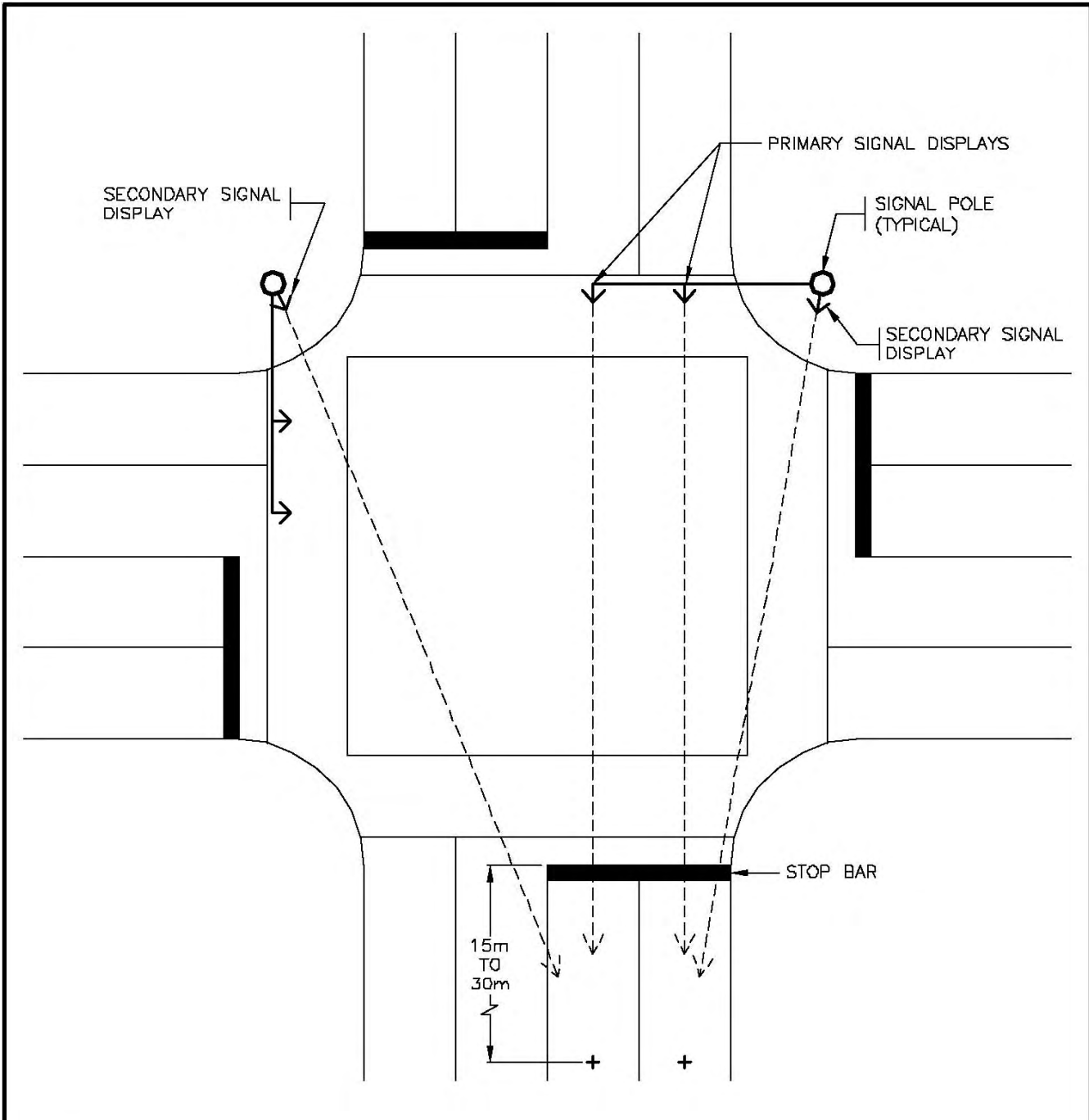

NOTES

1. DESIGNER SHALL REVIEW SIGNAL HEAD AIMING PRIOR TO SIGNAL START UP.
2. SIGNAL HEADS SHALL BE VISIBLE FROM THE MINIMUM DISTANCE SHOWN IN THE TAC MANUAL OF UNIFORM TRAFFIC CONTROL DEVICES.



NOT TO SCALE

No.	Revision	Date	SIGNAL HEAD AIMING DIAGRAM	
F			Date	Approved
E			14/11/03	D.N. (Signature on File)
D				Chief Engineer
C				SPECIFICATION DRAWING No.
B				SP635-2.3.11
A				

NOTES

1. SEE STANDARD SPECIFICATIONS & SPECIAL PROVISIONS FOR ADDITIONAL INFORMATION.
2. EXACT HEIGHT OF CAMERA ARM WILL VARY AS SHOWN ON THE CONTRACT DRAWINGS. ARM SHALL BE DESIGNED & SEALED BY POLE SUPPLIER'S STRUCTURAL ENGINEER IN ACCORDANCE WITH MINISTRY ELECTRICAL & SIGNING MATERIAL STANDARDS (SUPPLY SHOP DRAWINGS PRIOR TO FABRICATION)

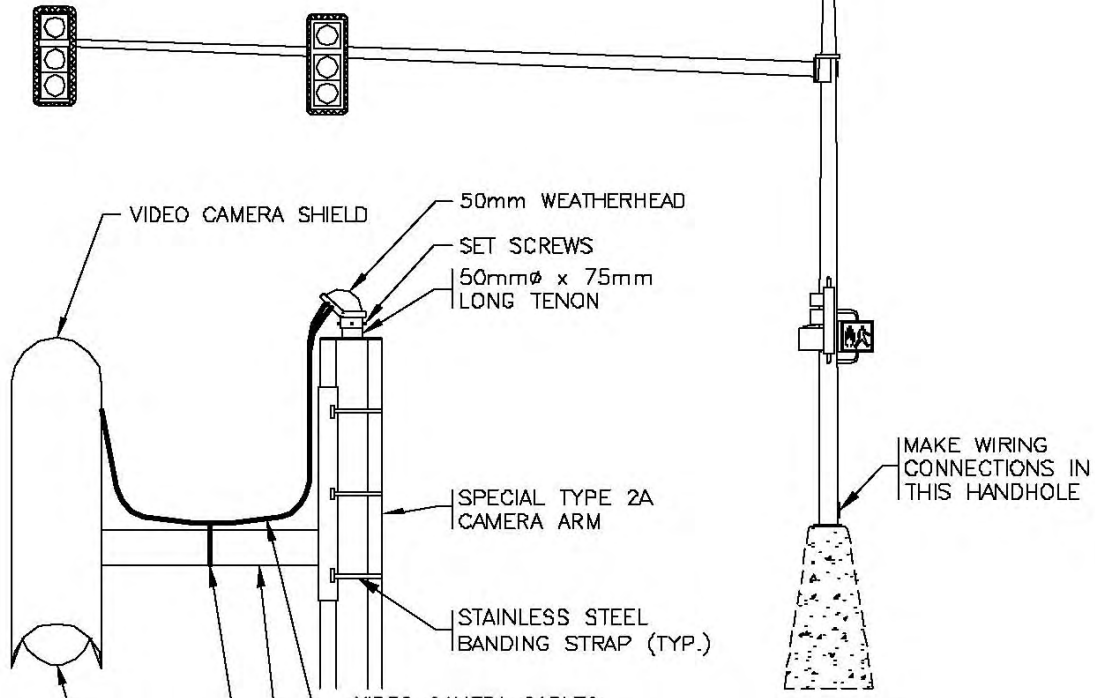
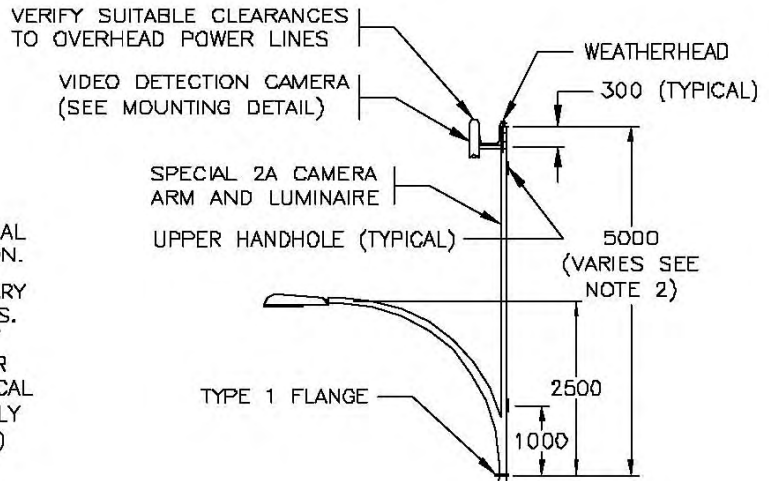

VIDEO DETECTION CAMERA POLE MOUNTING DETAIL

N.T.S.

aaaa

ELEVATION

NOT TO SCALE



No.	Revision	Date
F		
E		
D		
C		
B		
A		

VIDEO DETECTION INSTALLATION DETAIL ON SPECIAL 2A ARM		
Date	Approved	SPECIFICATION DRAWING No.
14/11/03	D.N. (Signature on File) Chief Engineer	SP635-2.3.12

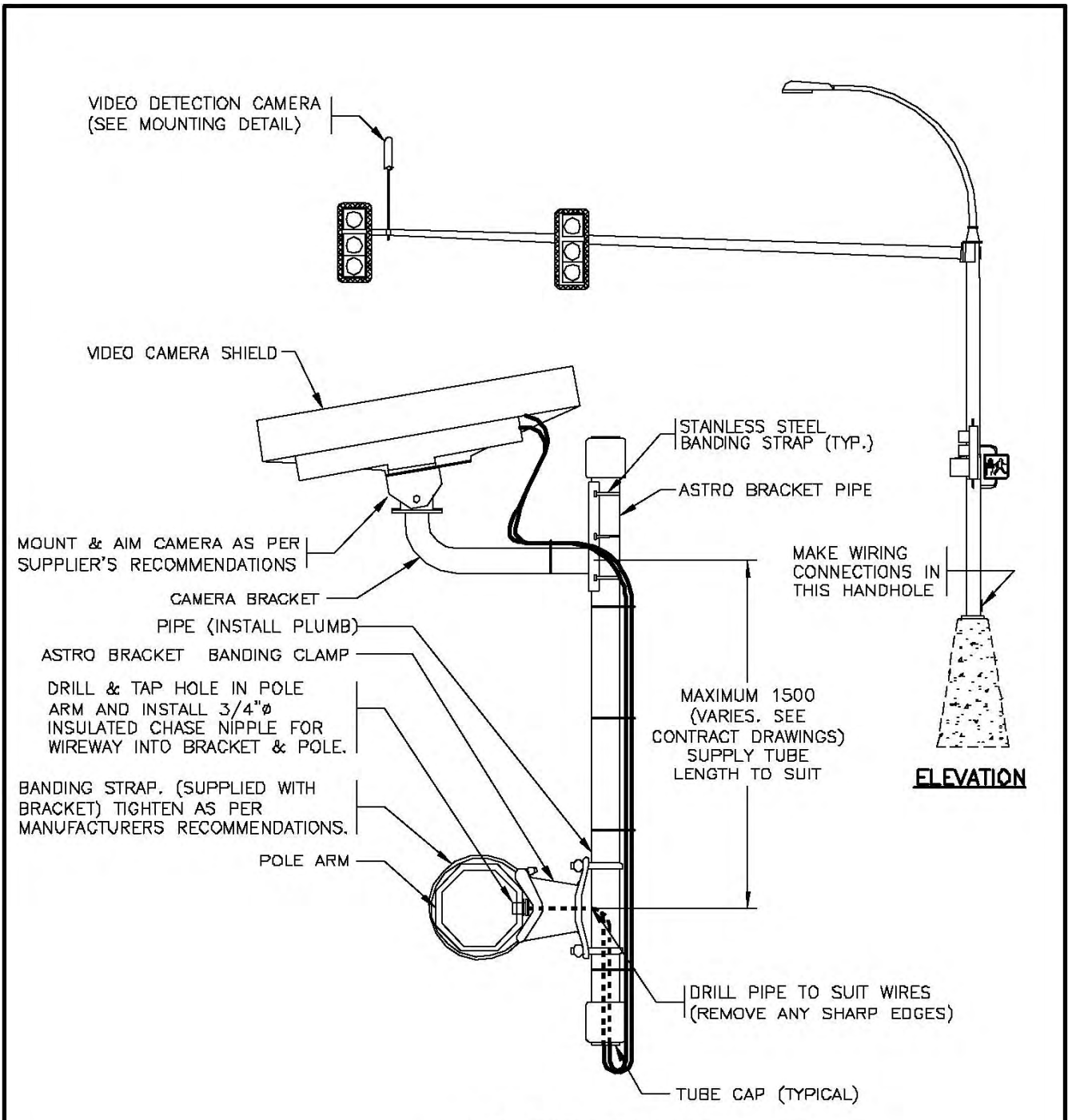

**VIDEO DETECTOR CAMERA
SIGNAL ARM MOUNTING DETAIL**

aaaa N.T.S.

NOTES

- 1. SEE STANDARD SPECIFICATIONS & SPECIAL PROVISIONS FOR ADDITIONAL INFORMATION.

NOT TO SCALE



No.	Revision	Date
F		
E		
D		
C		
B		
A		

VIDEO DETECTION INSTALLATION DETAIL ON SIGNAL ARM		
Date	Approved	SPECIFICATION DRAWING No.
14/11/03	D.N. (Signature on File) Chief Engineer	SP635-2.3.13

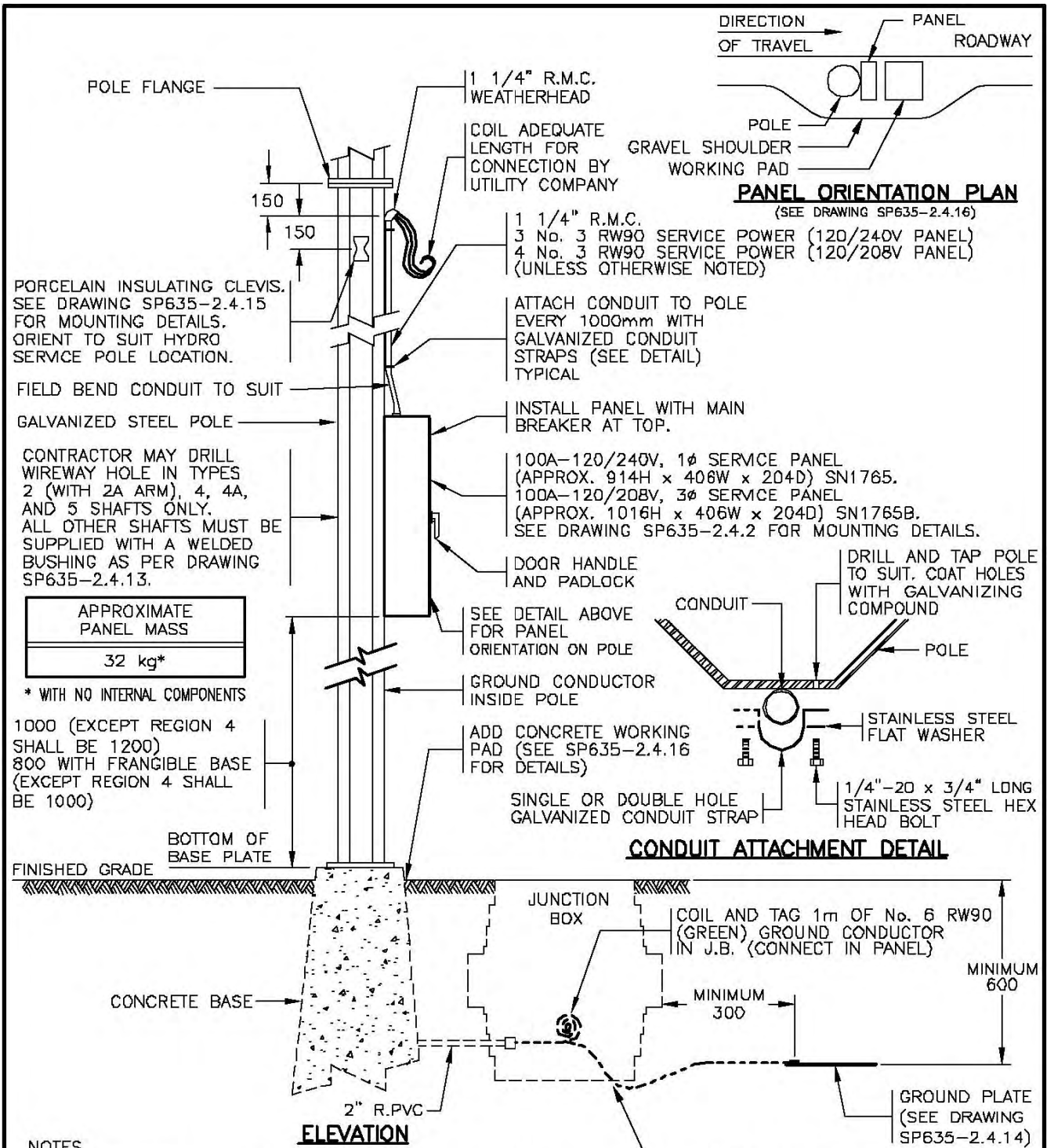

- NOTES**
1. SEE STANDARD SPECIFICATIONS & SPECIAL PROVISIONS FOR ADDITIONAL INFORMATION.
 2. 'SN' DENOTES MINISTRY STOCK NUMBER.
 3. ALL DIMENSIONS ARE IN MILLIMETRES UNLESS OTHERWISE NOTED.

NOT TO SCALE



No.	Revision	Date	100A - OVERHEAD DROP SERVICE INSTALLATION DETAILS		DATE	APPROVED	SPECIFICATION DRAWING No.
E							
D	MOUNTING HEIGHT REVISED	AUG 99					
C	MOUNTING HEIGHT CHANGED TO FINISHED GRADE & PANEL ORIENTATION DETAIL ADDED	NOV 98	Date	Approved			
B	GROUND PLATE ADDED	AUG 95	12/10/93	E.L. (Signature on File)			SP635-2.4.1
A	GENERAL REVISIONS	AUG 94	Chief Highway Engineer				

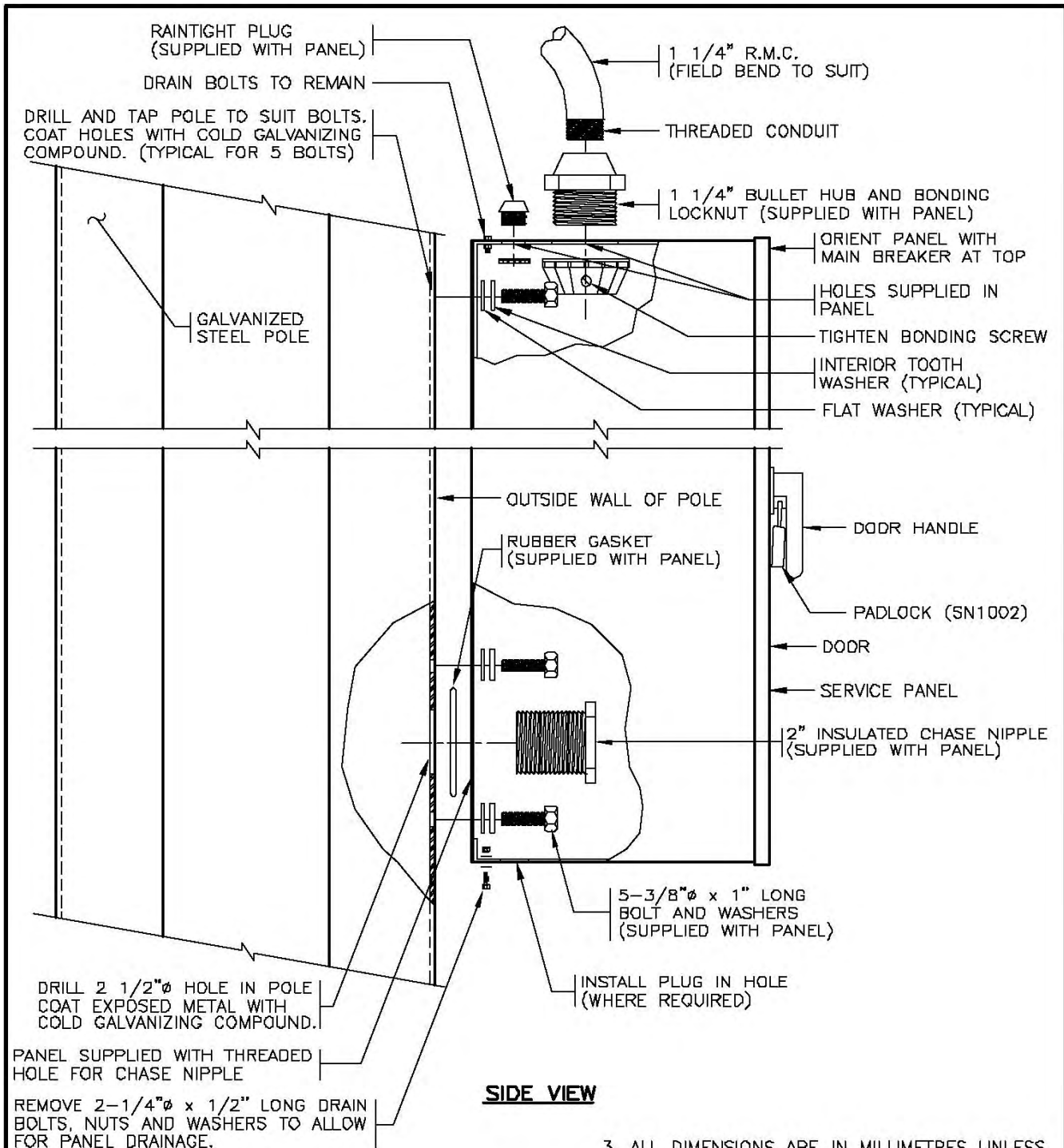

SIDE VIEW

NOTES

1. SEE STANDARD SPECIFICATIONS & SPECIAL PROVISIONS FOR ADDITIONAL INFORMATION.
2. 'SN' DENOTES MINISTRY STOCK NUMBER.

3. ALL DIMENSIONS ARE IN MILLIMETRES UNLESS OTHERWISE NOTED.
4. PANEL ASSEMBLY AND INSTALLATION INSTRUCTIONS SUPPLIED WITH PANEL.

NOT TO SCALE



No.	Revision	Date
F		
E		
D		
C	BONDING LOCKNUT ADDED	AUG 96
B	GROUND CONDUIT DELETED	AUG 95
A	GENERAL REVISIONS	AUG 94

100A - SERVICE PANEL INSTALLATION DETAILS FOR OVERHEAD DROP SERVICE		
Date	Approved	SPECIFICATION DRAWING No.
12/10/93	E.L. (Signature on File) Chief Highway Engineer	SP635-2.4.2

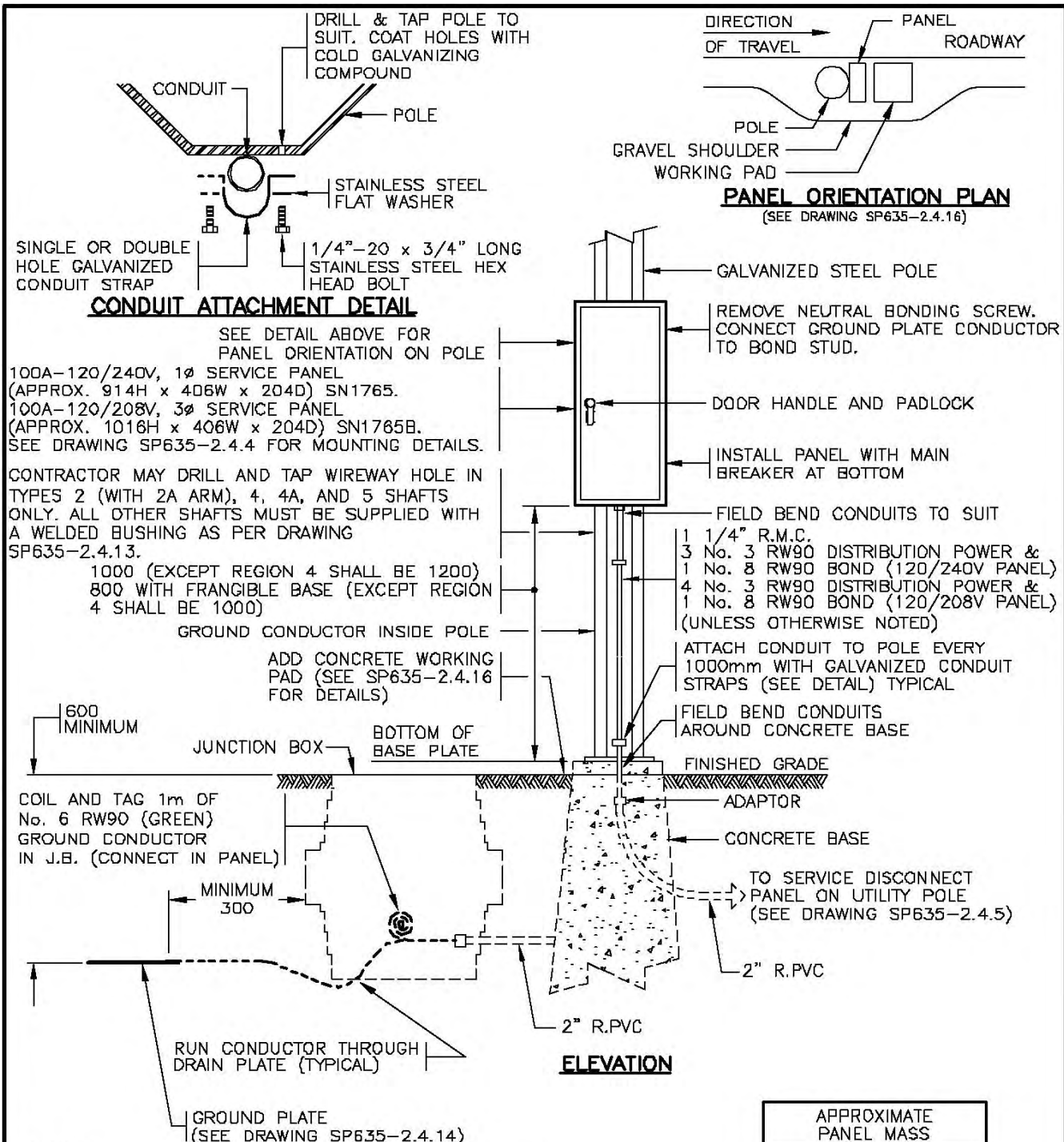

- NOTES**
1. SEE STANDARD SPECIFICATIONS & SPECIAL PROVISIONS FOR ADDITIONAL INFORMATION.
 2. "SN" DENOTES MINISTRY STOCK NUMBER.
 3. ALL DIMENSIONS ARE IN MILLIMETRES UNLESS OTHERWISE NOTED.

APPROXIMATE PANEL MASS
30 kg*
* WITH NO INTERNAL COMPONENTS



NOT TO SCALE			100A - UNDERGROUND DIP SERVICE INSTALLATION DETAILS		
No.	Revision	Date			
D	BOND CONDUCTOR & GROUND PLATE CONDUCTOR CONNECTION CLARIFIED, MOUNTING HEIGHT REVISED	AUG 99			SP635-2.4.3
C	MOUNTING HEIGHT CHANGED TO FINISHED GRADE & PANEL ORIENTATION DETAIL ADDED	NOV 98	12/10/93	E.L. (Signature on File)	
B	GROUND PLATE ADDED	AUG 95		Chief Highway Engineer	
A	GENERAL REVISIONS	AUG 94			

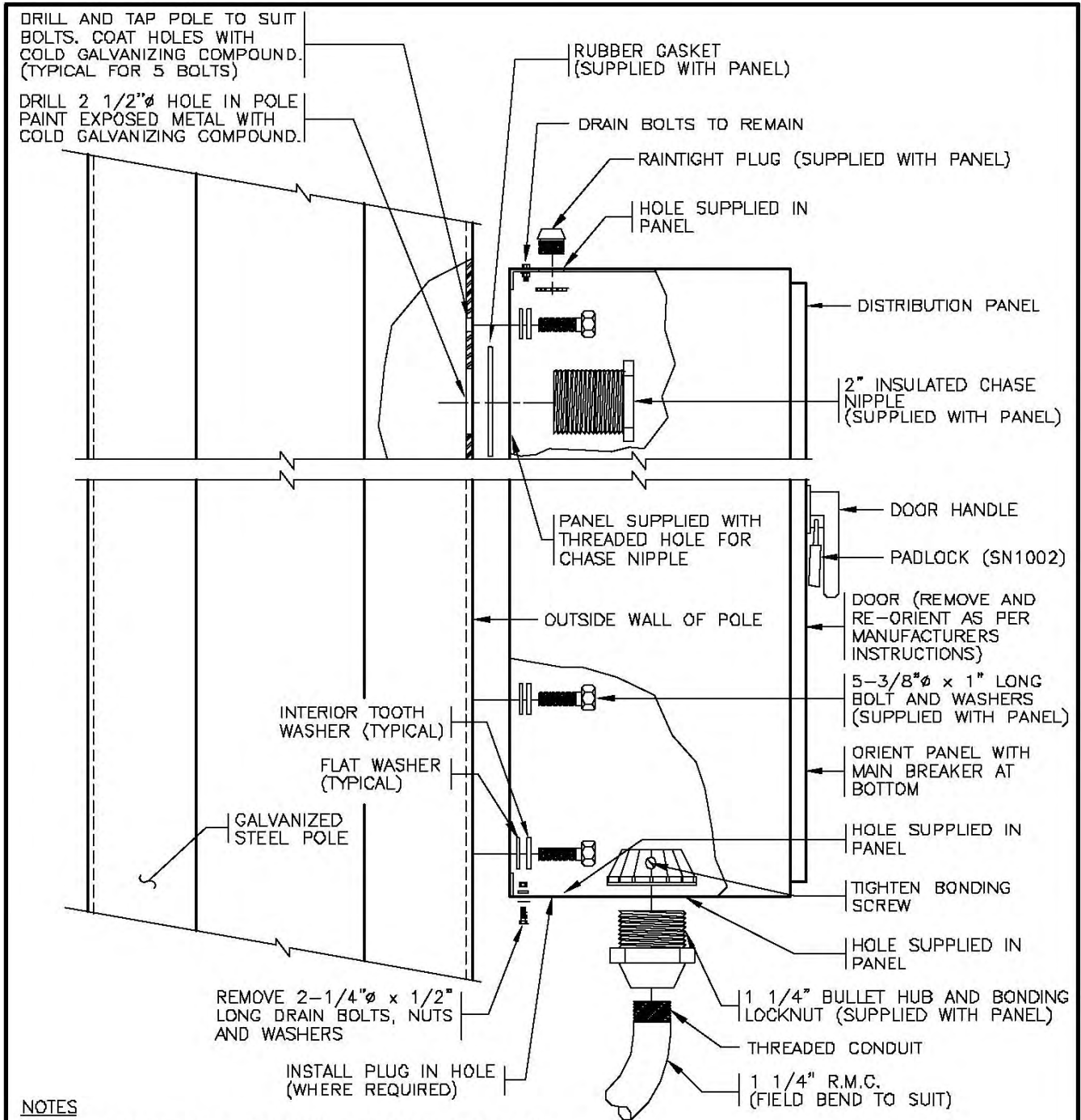

NOTES

1. SEE STANDARD SPECIFICATIONS & SPECIAL PROVISIONS FOR ADDITIONAL INFORMATION.
2. 'SN' DENOTES MINISTRY STOCK NUMBER.
3. ALL DIMENSIONS ARE IN MILLIMETRES UNLESS OTHERWISE NOTED.
4. PANEL ASSEMBLY AND INSTALLATION INSTRUCTIONS SUPPLIED WITH PANEL.

aaaa **SIDE VIEW**

NOT TO SCALE



No.	Revision	Date
F		
E		
D		
C	BONDING LOCKNUT ADDED	AUG 96
B	GROUND CONDUIT DELETED	AUG 95
A	GENERAL REVISIONS	AUG 94

**100A – DISTRIBUTION PANEL INSTALLATION
DETAILS FOR UNDERGROUND DIP SERVICE**

Date **12/10/93** Approved **E.L. (Signature on File)**
Chief Highway Engineer

SPECIFICATION
DRAWING No.
SP635-2.4.4

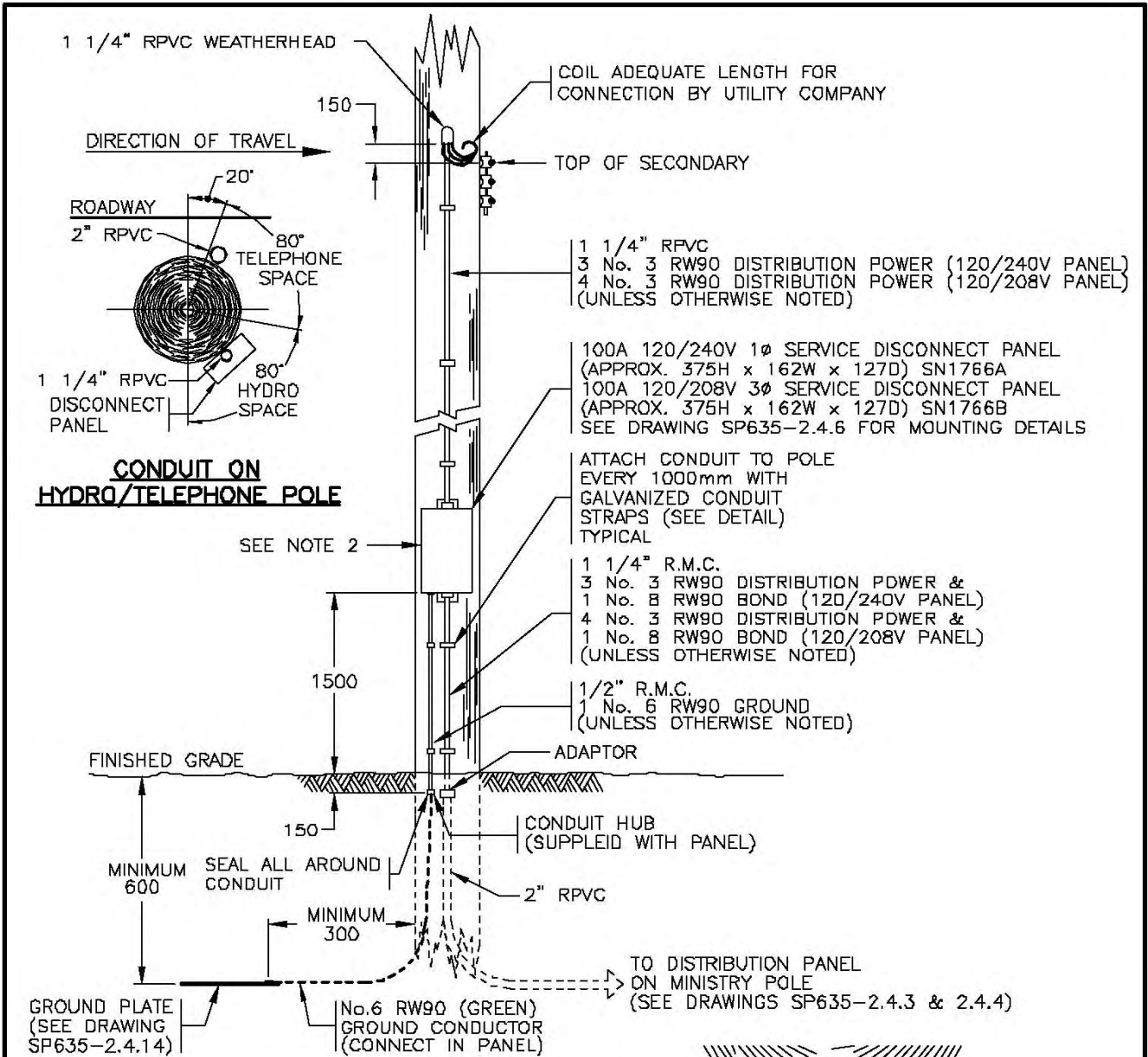

NOTES

1. SEE STANDARD SPECIFICATIONS & SPECIAL PROVISIONS FOR ADDITIONAL INFORMATION.
2. CONTRACTOR TO OBTAIN PERMISSION FROM UTILITY COMPANY BEFORE INSTALLING EQUIPMENT ON POLE.
3. 'SN' DENOTES MINISTRY STOCK NUMBER.
4. MOUNT CONDUIT AND PANEL ON CONCRETE UTILITY POLE WITH 3/4" STAINLESS STEEL BANDING.
5. ALL DIMENSIONS ARE IN MILLIMETRES UNLESS OTHERWISE NOTED.

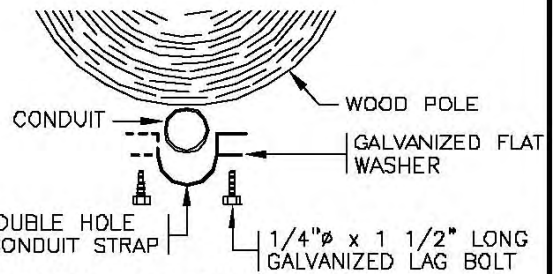

CONDUIT ATTACHMENT DETAIL

NOT TO SCALE



No.	Revision	Date
F		
E		
D	CONDUIT AND WEATHERHEAD RPVC	APR 05
C	BOND CONDUCTORS ADDED	AUG 99
B	GROUND PLATE ADDED	AUG 95
A	GENERAL REVISIONS	AUG 94

Date		Approved	SPECIFICATION DRAWING No.
30/09/93		E.L. (Signature on File) Chief Highway Engineer	SP635-2.4.5

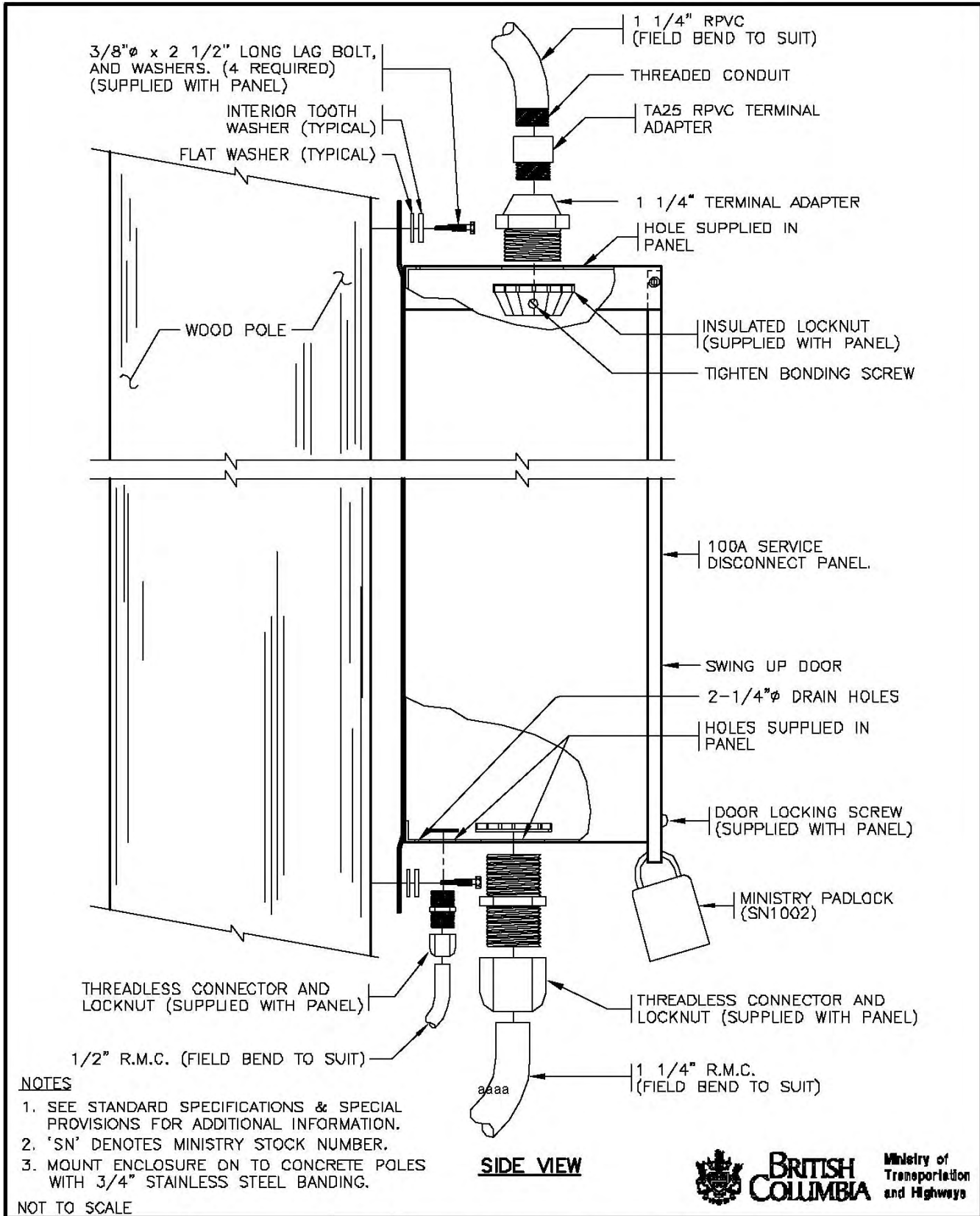

NOTES

1. SEE STANDARD SPECIFICATIONS & SPECIAL PROVISIONS FOR ADDITIONAL INFORMATION.
2. 'SN' DENOTES MINISTRY STOCK NUMBER.
3. MOUNT ENCLOSURE ON TO CONCRETE POLES WITH 3/4" STAINLESS STEEL BANDING.

NOT TO SCALE



No.	Revision	Date	100A - SERVICE DISCONNECT PANEL INSTALLATION DETAILS		SPECIFICATION DRAWING No. SP635-2.4.6
F			Date	Approved	
E			12/10/93	E.L. (Signature on File)	
D				Chief Highway Engineer	
C	RPVC CONDUIT/ADAPTER ADDED	APR 05			
B	BONDING LOCKNUT ADDED	AUG 96			
A	GENERAL REVISIONS	AUG 94			

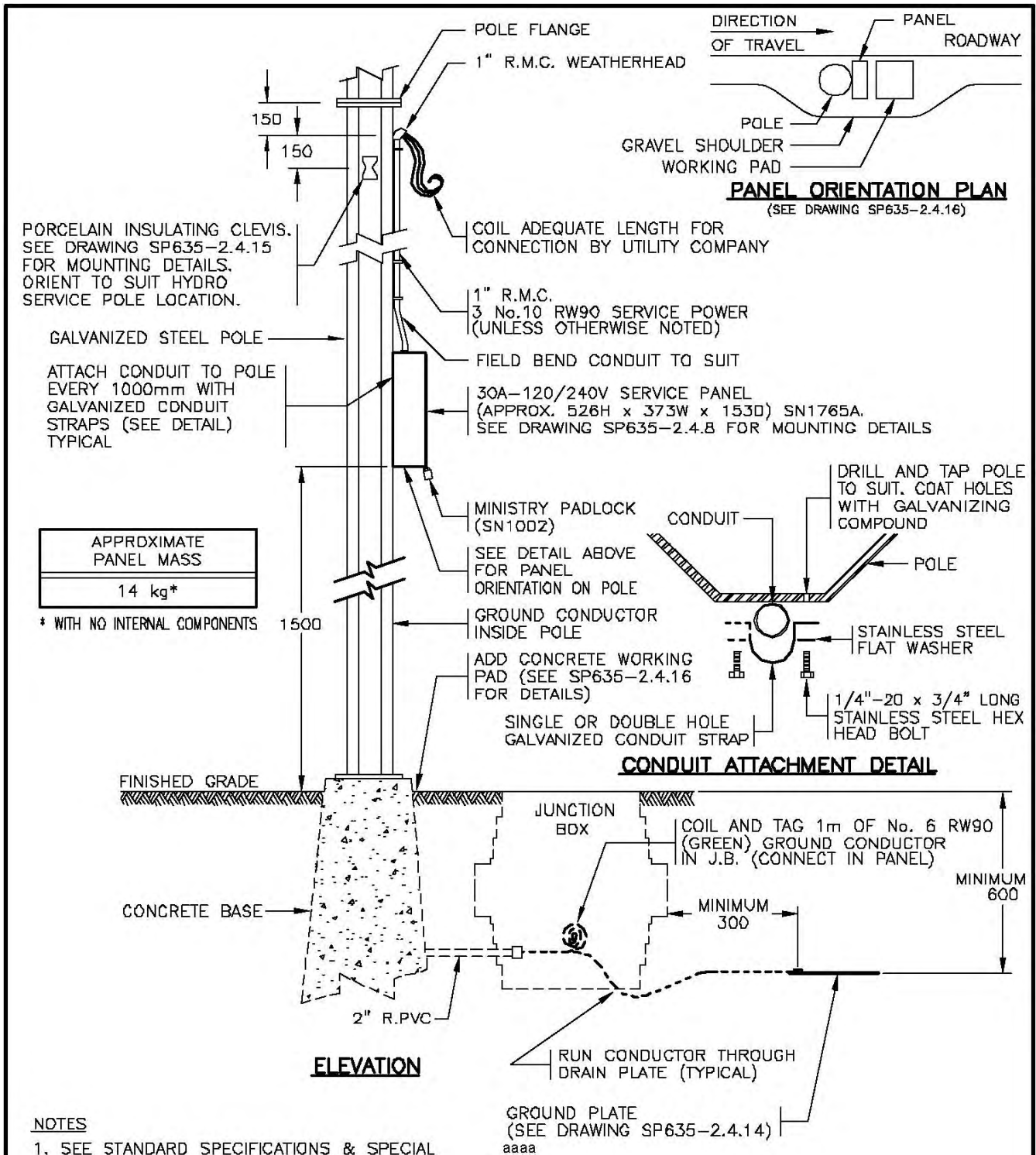

NOT TO SCALE



No.	Revision	Date
E		
D		
C		
B	MOUNTING HEIGHT CHANGED TO FINISHED GRADE & PANEL ORIENTATION DETAIL ADDED	NOV 98
A	GROUND PLATE ADDED	AUG 95

30A-120/240V OVERHEAD DROP SERVICE INSTALLATION DETAILS

Date: 18/11/94
Approved: E.L. (Signature on File)
Chief Highway Engineer

SPECIFICATION DRAWING No. SP635-2.4.7

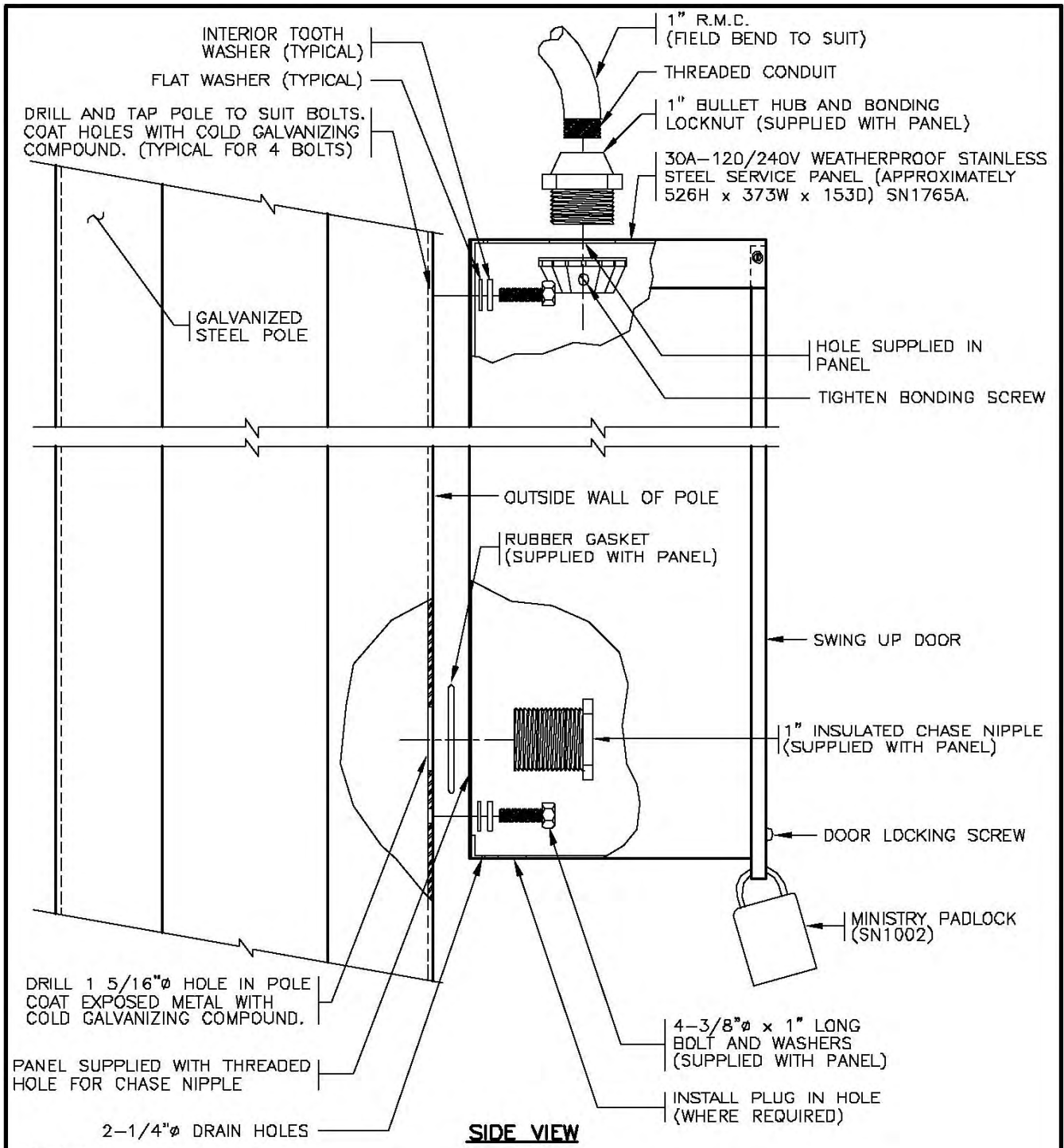

SIDE VIEW

- NOTES**
1. SEE STANDARD SPECIFICATIONS & SPECIAL PROVISIONS FOR ADDITIONAL INFORMATION.
 2. 'SN' DENOTES MINISTRY STOCK NUMBER.
 3. ALL DIMENSIONS ARE IN MILLIMETRES UNLESS OTHERWISE NOTED.



NOT TO SCALE

No.	Revision	Date	30A-120/240V SERVICE PANEL INSTALLATION DETAILS FOR OVERHEAD DROP SERVICE		SPECIFICATION DRAWING No. SP635-2.4.8
F			Date	Approved	
E			18/11/94	E.L. (Signature on File)	
D				Chief Highway Engineer	
C					
B	BONDING LOCKNUT ADDED	AUG 96			
A	GROUND CONDUIT DELETED	AUG 95			

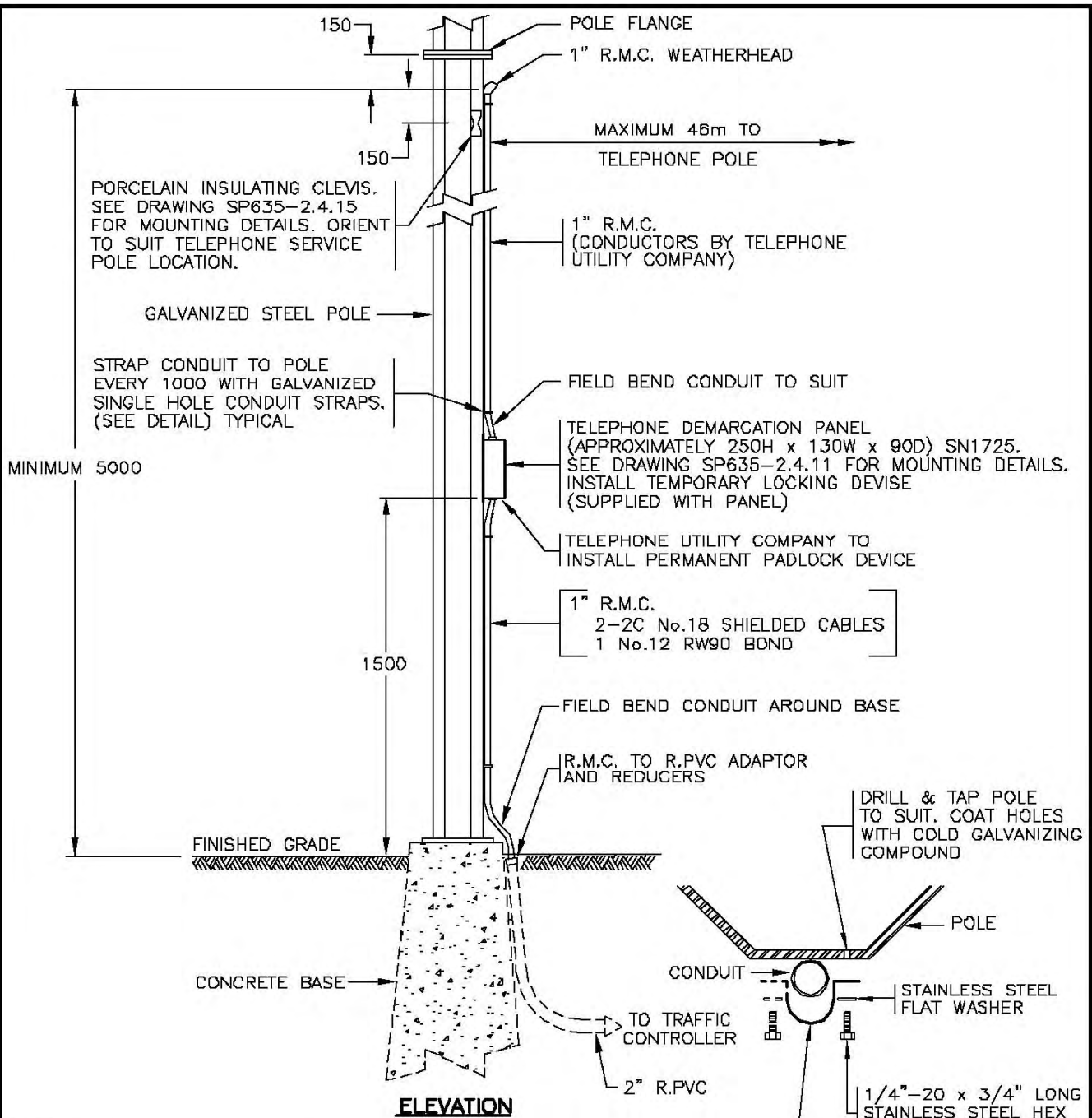

NOTES

1. SEE STANDARD SPECIFICATIONS AND SPECIAL PROVISIONS FOR ADDITIONAL INFORMATION.
2. *SN* DENOTES MINISTRY STOCK NUMBER.
3. ALL DIMENSIONS ARE IN MILLIMETRES UNLESS OTHERWISE NOTED.
4. WHERE PANEL AND CONDUITS ARE TO BE INSTALLED ON A TELEPHONE/POWER POLE THE INSTALLATION SHALL BE CARRIED OUT BY THE TELEPHONE UTILITY COMPANY.

NOT TO SCALE



No.	Revision	Date
F		
E		
D		
C	TEMPORARY LOCKING DEVICE NOTE ADDED	SEPT 00
B	MOUNTING HEIGHT CHANGED TO FINISHED GRADE	NOV 98
A	PANEL SIZE & STOCK NUMBER REVISED	AUG 96

TELEPHONE OVERHEAD DROP SERVICE INSTALLATION DETAILS		
Date	Approved	SPECIFICATION DRAWING No.
18/11/94	E.L. (Signature on File) Chief Highway Engineer	SP635-2.4.9

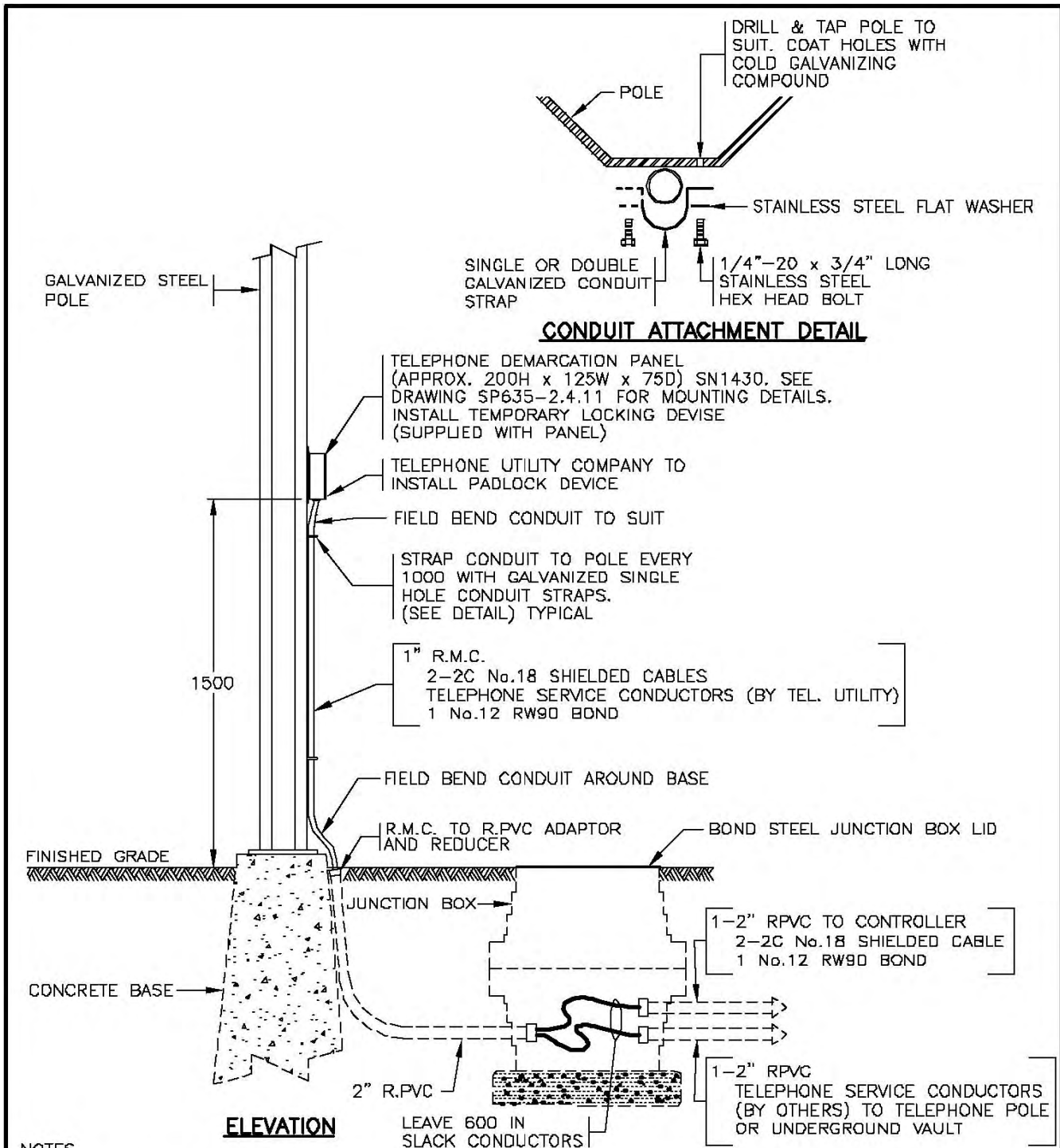

NOTES

1. SEE STANDARD SPECIFICATIONS AND SPECIAL PROVISIONS FOR ADDITIONAL INFORMATION.
2. 'SN' DENOTES MINISTRY STOCK NUMBER.
3. ALL DIMENSIONS ARE IN MILLIMETRES UNLESS OTHERWISE NOTED.

NOT TO SCALE



No.	Revision	Date
F		
E		
D		
C		
B	TEMPORARY LOCKING DEVICE NOTE ADDED	SEPT 00
A	MOUNTING HEIGHT CHANGED TO FINISHED GRADE	NOV 98

TELEPHONE UNDERGROUND SERVICE INSTALLATION DETAILS		
Date	Approved	SPECIFICATION DRAWING No.
18/11/94	E.L. (Signature on File) Chief Highway Engineer	SP635-2.4.10

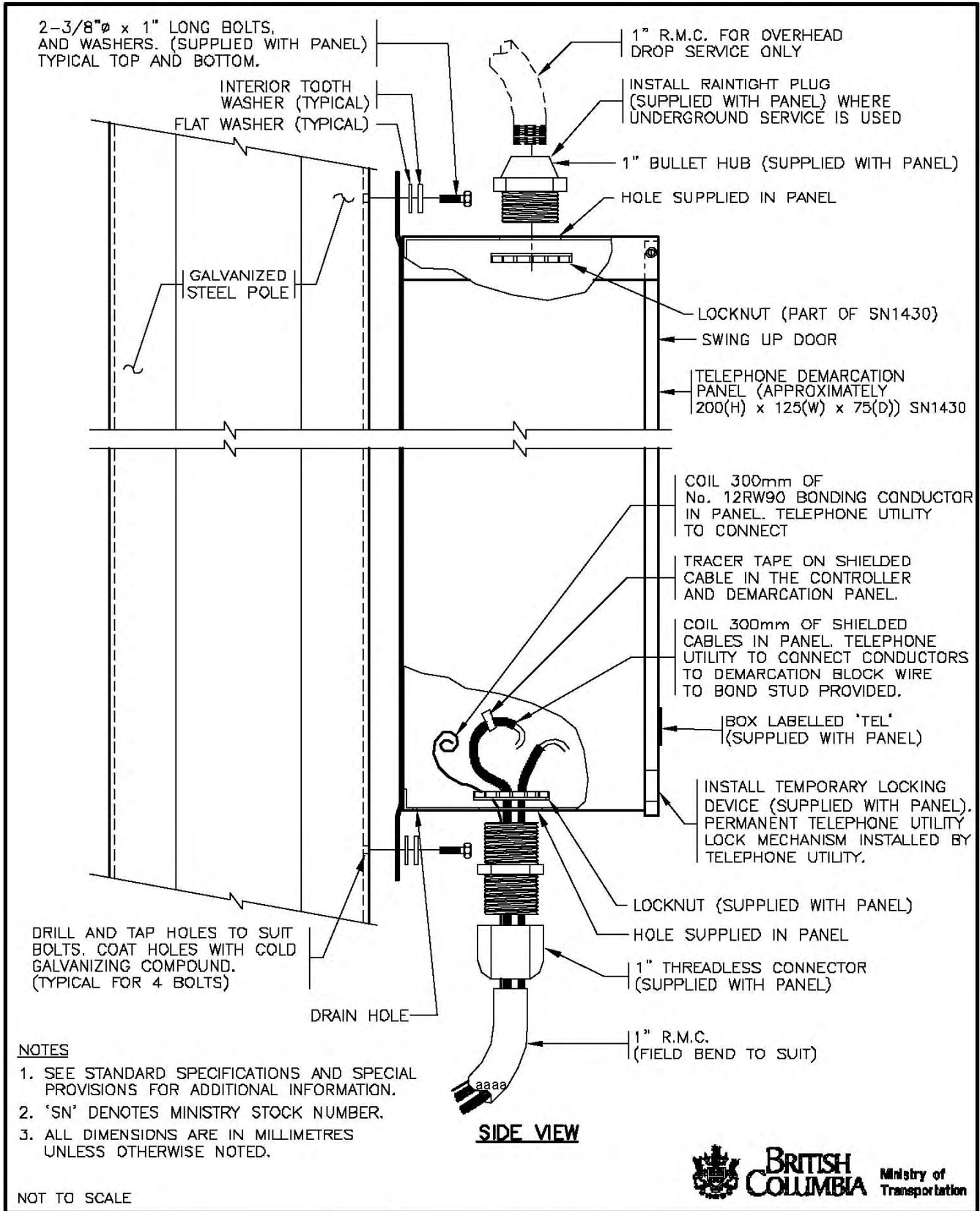

NOTES

1. SEE STANDARD SPECIFICATIONS AND SPECIAL PROVISIONS FOR ADDITIONAL INFORMATION.
2. 'SN' DENOTES MINISTRY STOCK NUMBER.
3. ALL DIMENSIONS ARE IN MILLIMETRES UNLESS OTHERWISE NOTED.

NOT TO SCALE



No.	Revision	Date
F		
E		
D		
C		
B		
A	TEMPORARY LOCKING DEVICE NOTE ADDED	SEPT 00

TELEPHONE DEMARCATION PANEL INSTALLATION DETAILS		
Date	Approved	SPECIFICATION DRAWING No.
18/11/94	E.L. (Signature on File) Chief Highway Engineer	SP635-2.4.11

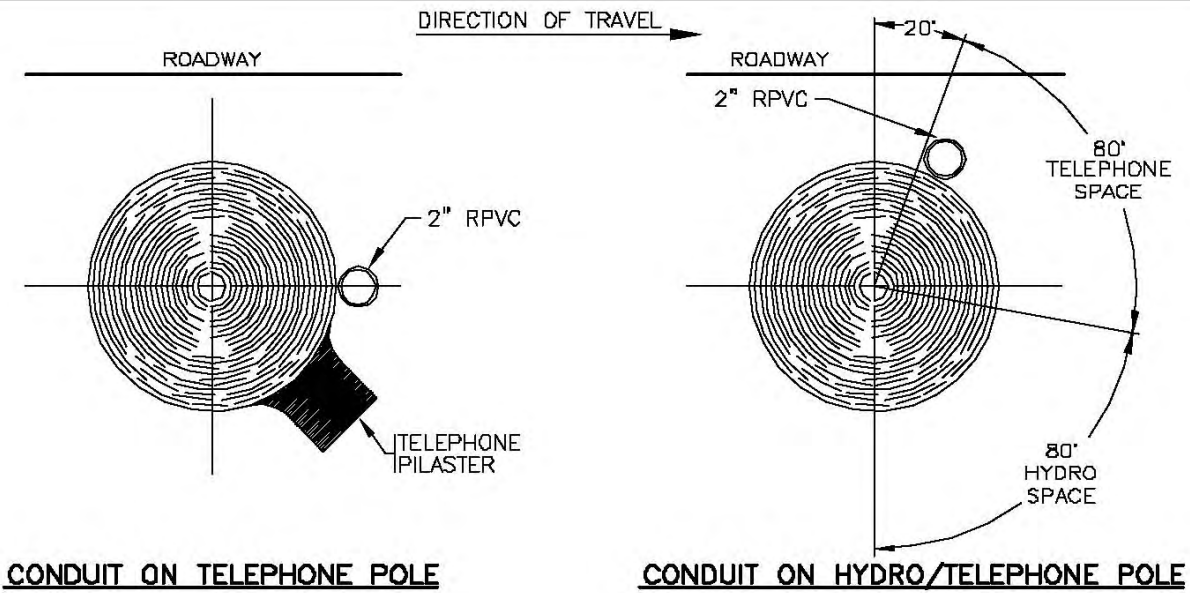

PLAN VIEWS

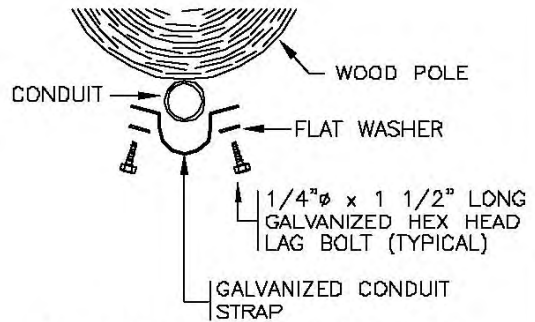
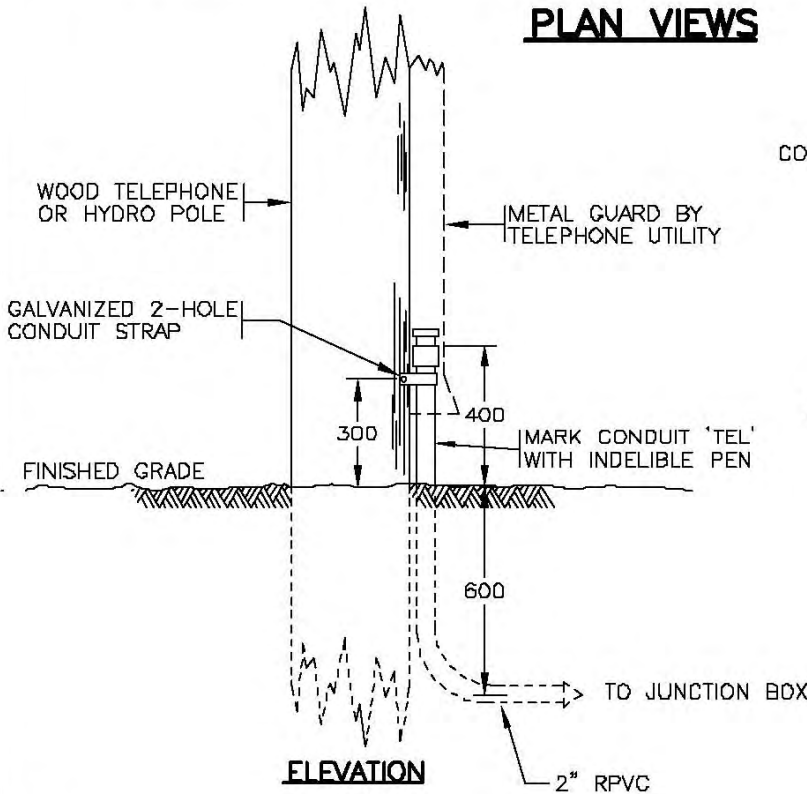

CONDUIT ATTACHMENT DETAIL

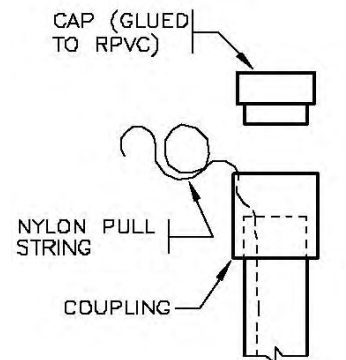

CAP DETAIL

NOTES

1. SEE STANDARD SPECIFICATIONS AND SPECIAL PROVISIONS FOR ADDITIONAL INFORMATION.
2. ALL DIMENSIONS ARE IN MILLIMETRES UNLESS OTHERWISE NOTED.

aaaa

NOT TO SCALE



No.	Revision	Date
F		
E		
D		
C		
B		
A		

TELEPHONE CONDUIT INSTALLATION DETAILS (WOOD POLE)

Date: **18/11/94**
 Approved: **E.L. (Signature on File)**
 Chief Highway Engineer

SPECIFICATION DRAWING No. **SP635-2.4.12**

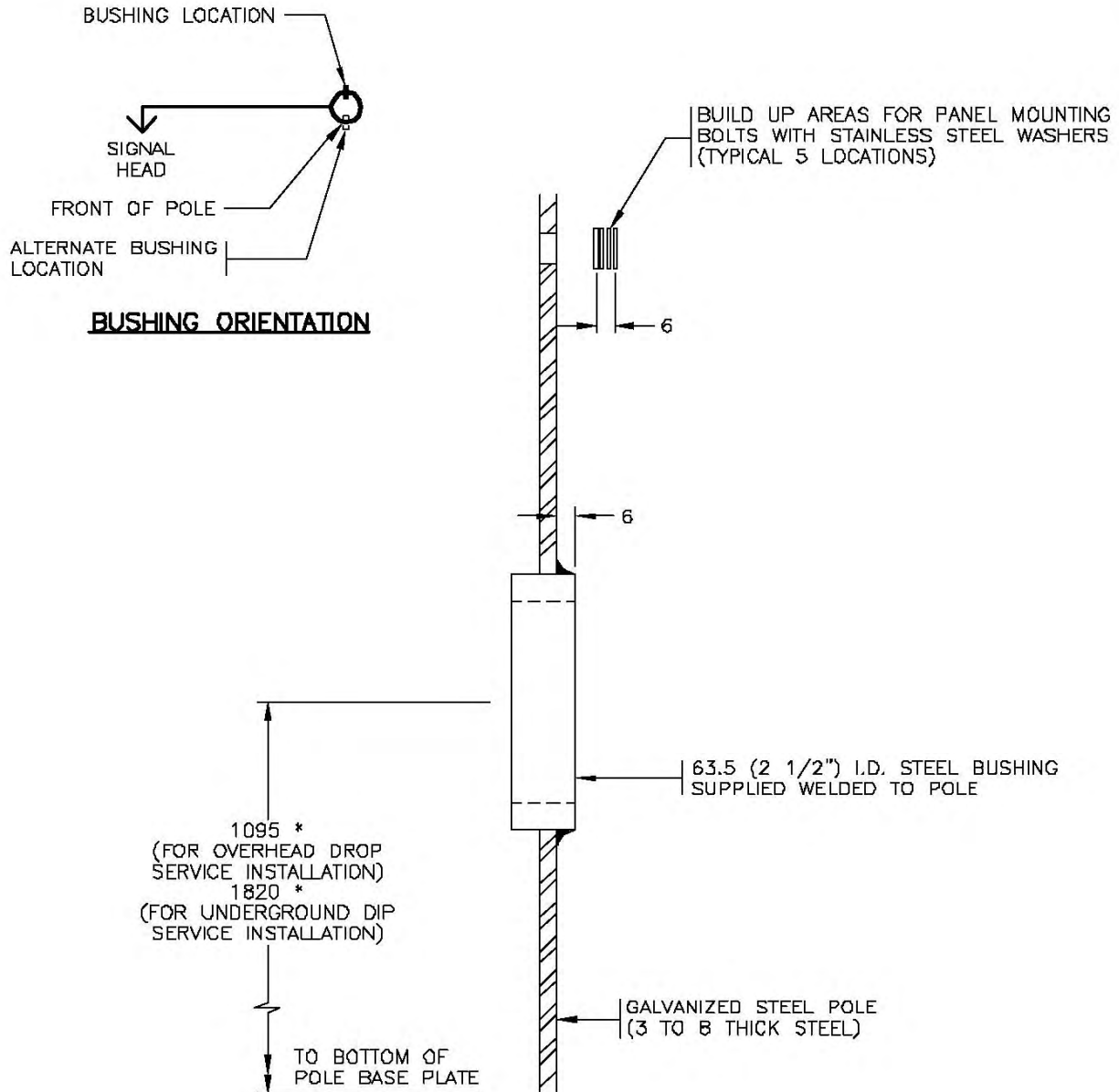

*** ONLY IN REGION 3**
 1295 (FOR O/H DROP SERVICE INSTALLATION)
 2020 (FOR U/G DIP SERVICE INSTALLATION)

POLE SHALL BE SUPPLIED WITH BUSHING INSTALLED, UNLESS OTHERWISE NOTED

NOTES

- SEE STANDARD SPECIFICATIONS AND SPECIAL PROVISIONS FOR ADDITIONAL INFORMATION.
- ALL DIMENSIONS ARE IN MILLIMETRES.

aaaa



NOT TO SCALE

No.	Revision	Date
F		
E		
D	REGION 4 CHANGED TO 3	OCT 03
C	BUSHING LOCATION REVISED	AUG 99
B	BUSHING LOCATION REVISED	AUG 96
A	BUSHING ORIENTATION & MOUNTING HEIGHTS ADDED	AUG 95

SERVICE PANEL BUSHING DETAIL		
Date	Approved	SPECIFICATION DRAWING No.
18/11/94	E.L. (Signature on File) Chief Highway Engineer	SP635-2.4.13

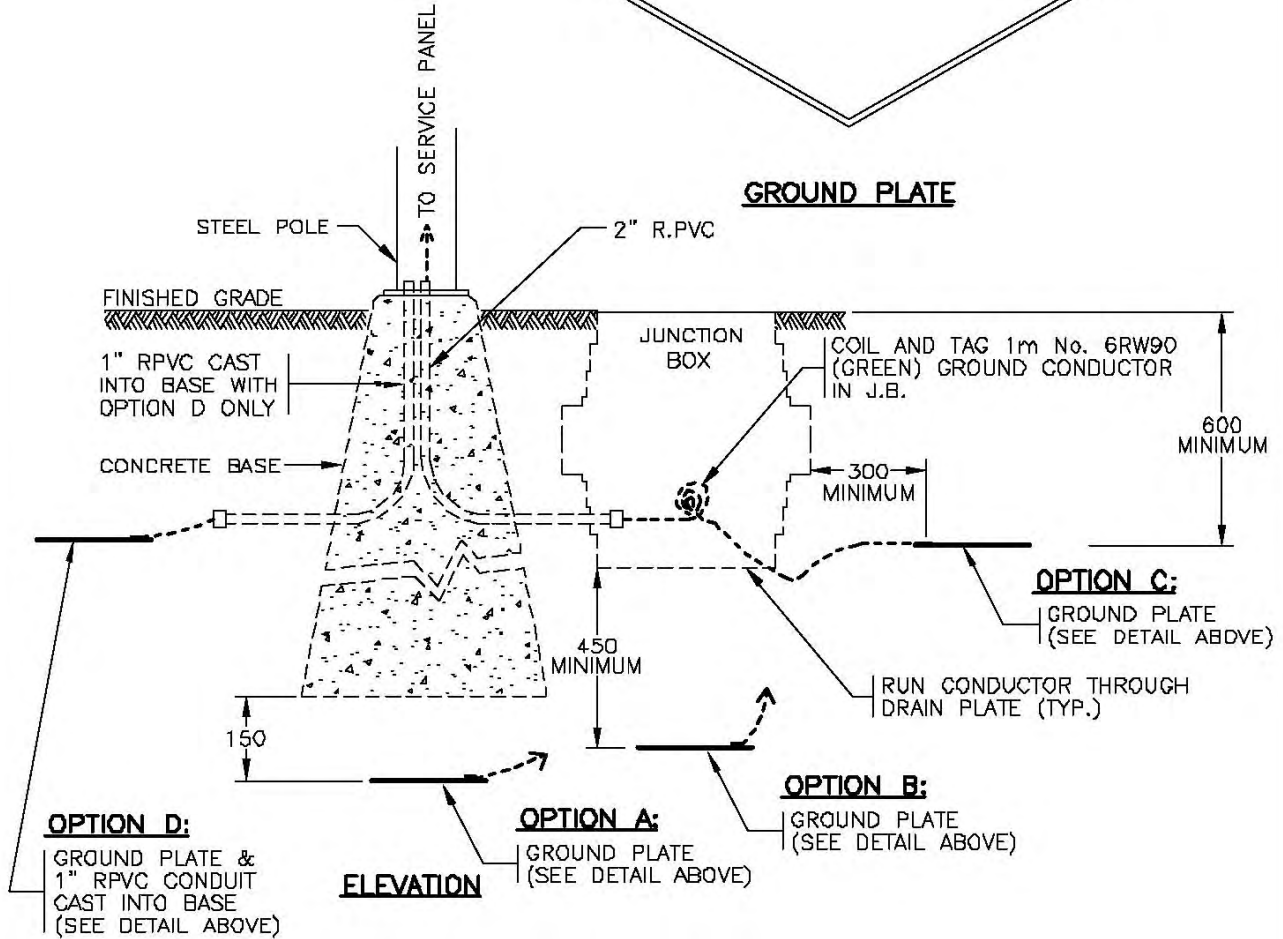
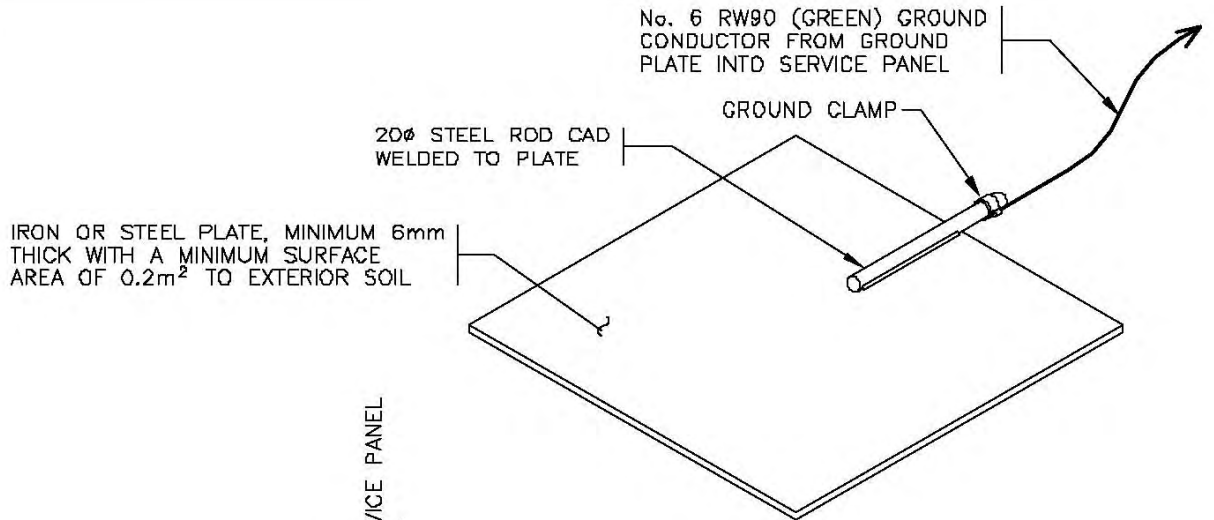

NOTES

1. SEE STANDARD SPECIFICATIONS & SPECIAL PROVISIONS FOR ADDITIONAL INFORMATION.
2. ALL DIMENSIONS ARE IN MILLIMETRES UNLESS OTHERWISE NOTED.
3. WHERE PLATE CAN NOT BE INSTALLED UNDER THE BASE IT SHALL BE INSTALLED AT A MINIMUM DEPTH OF 600mm BELOW FINISHED GRADE, BESIDE THE BASE

NOT TO SCALE



No.	Revision	Date
F		
E		
D		
C	GROUND PLATE REMISED	OCT 03
B	OPTION D ADDED	AUG 96
A	GENERAL REVISION	OCT 95

GROUND PLATE INSTALLATION DETAIL		
Date	Approved	SPECIFICATION DRAWING No.
18/11/94	E.L. (Signature on File) Chief Highway Engineer	SP635-2.4.14

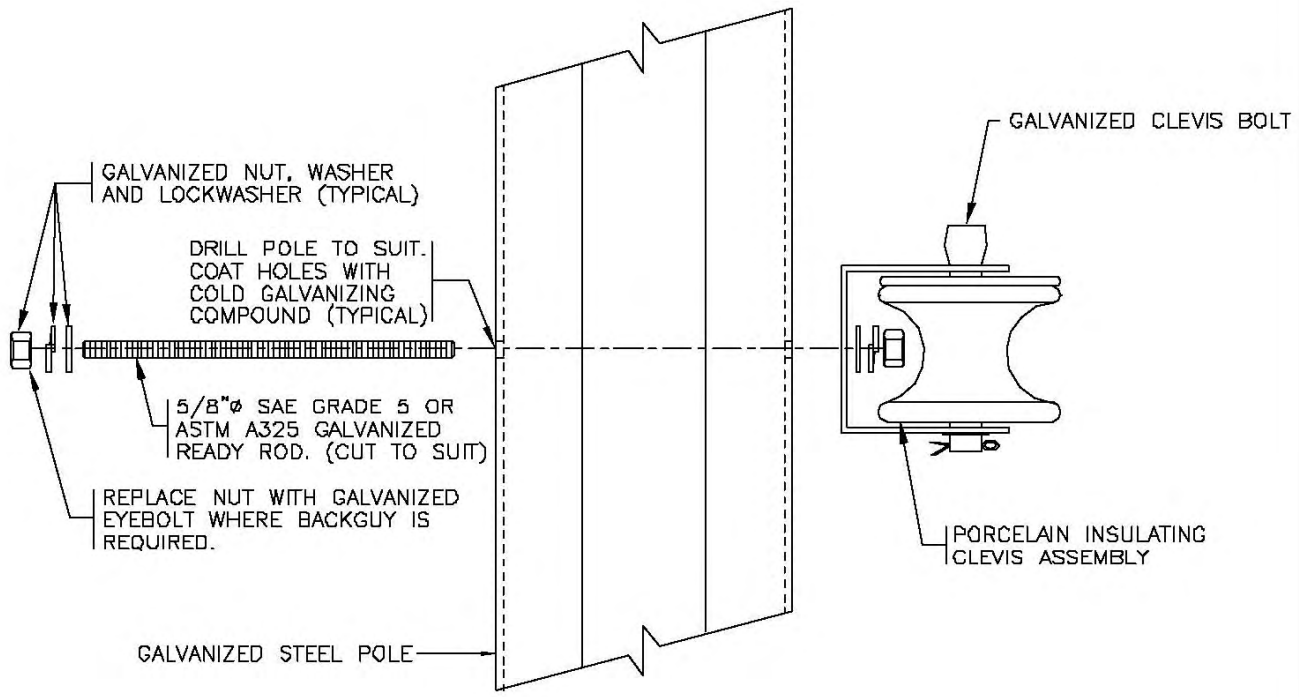

ELEVATION

aaaa

NOTES

- 1. SEE STANDARD SPECIFICATIONS & SPECIAL PROVISIONS FOR ADDITIONAL INFORMATION.

NOT TO SCALE



No.	Revision	Date
F		
E		
D		
C		
B		
A	GENERAL REVISIONS	AUG 94

INSULATING CLEVIS INSTALLATION DETAILS		
Date	Approved	SPECIFICATION DRAWING No.
30/09/93	E.L. (Signature on File) Chief Highway Engineer	SP635-2.4.15

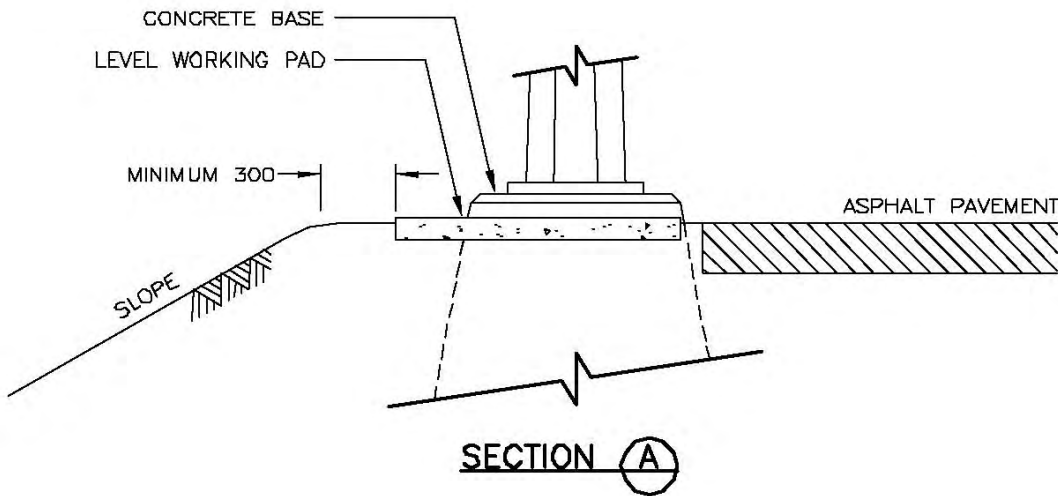
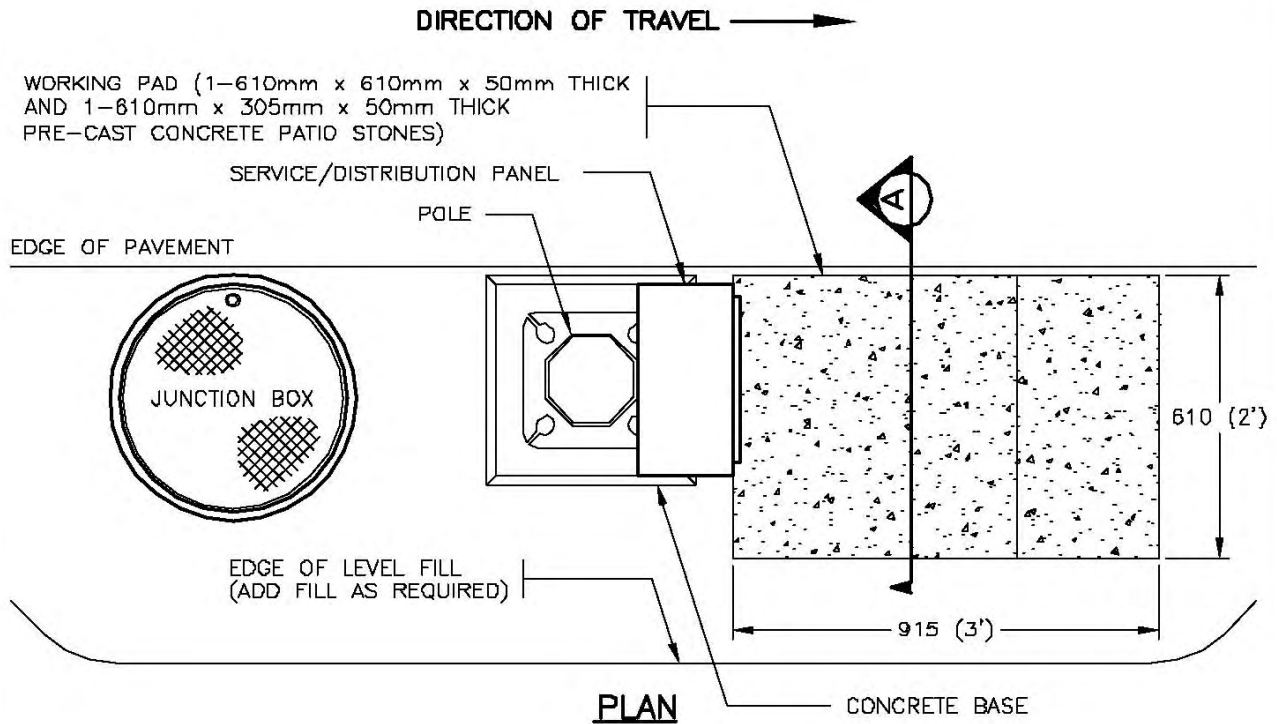

NOTES

1. SEE STANDARD SPECIFICATIONS & SPECIAL PROVISIONS FOR ADDITIONAL INFORMATION.
2. "SN" DENOTES MINISTRY STOCK NUMBER.
3. ALL DIMENSIONS ARE IN MILLIMETRES UNLESS OTHERWISE NOTED.

NOT TO SCALE



No.	Revision	Date
F		
E		
D		
C		
B		
A	ORIENTATION REVISED	SEPT 00

SERVICE PANEL WORKING PAD DETAIL

Date Approved
05/01/99 M.C. (Signature on File)
 Chief Highway Engineer

SPECIFICATION DRAWING No.
SP635-2.4.16

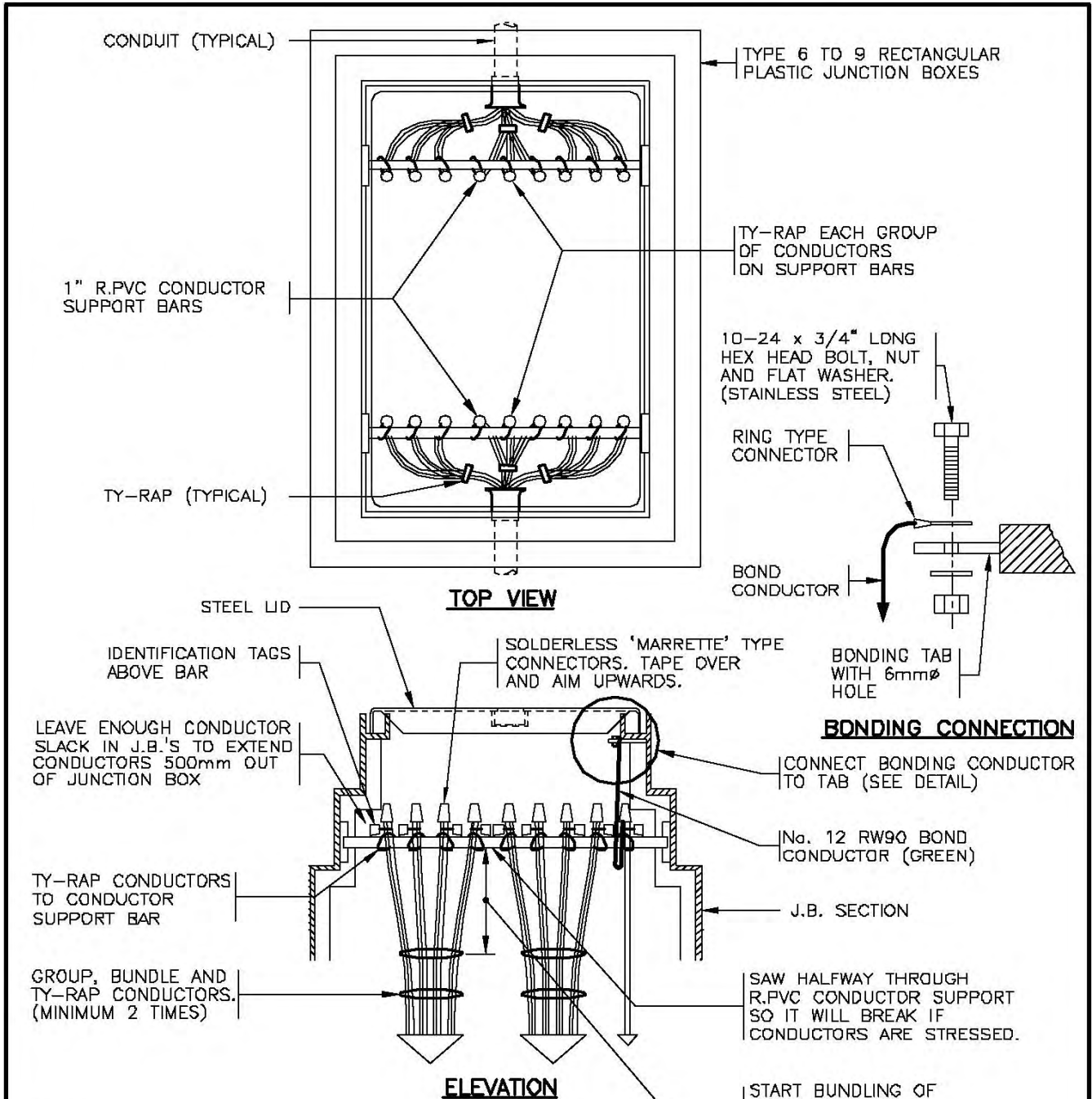

NOTES

1. SEE STANDARD SPECIFICATIONS & SPECIAL PROVISIONS FOR ADDITIONAL INFORMATION.
2. GROUP, BUNDLE & LABEL ALL CONDUCTORS SEPARATELY AS FOLLOWS:
 - DETECTOR LOOP CONDUCTORS
 - SIGNAL CONDUCTORS
 - LIGHTING & MISC. CONDUCTORS
3. IDENTIFICATION TAGS SHALL BE NEATLY MARKED WITH A BLACK INDELIBLE PEN.
4. SEE DRAWING SP635-2.5.7 FOR I.D. TAG TYPES AND DESIGNATIONS.
5. 'SN' DENOTES MINISTRY STOCK NUMBER.

NOT TO SCALE



No.	Revision	Date
F		
E		
D		
C		
B		
A	GENERAL REVISIONS	AUG 94

WIRING INSIDE TYPES 6 TO 9 RECTANGULAR PLASTIC JUNCTION BOXES		
Date	Approved	SPECIFICATION DRAWING No.
30/09/93	E.L. (Signature on File) Chief Highway Engineer	SP635-2.5.1

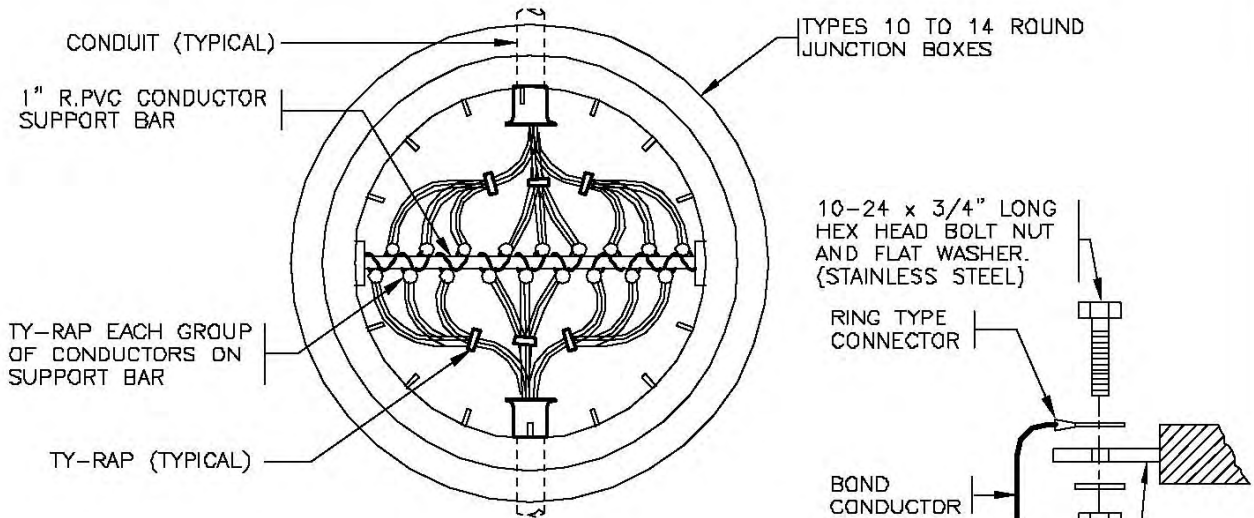

TOP VIEW

BONDING CONNECTION
(FOR STEEL LID)

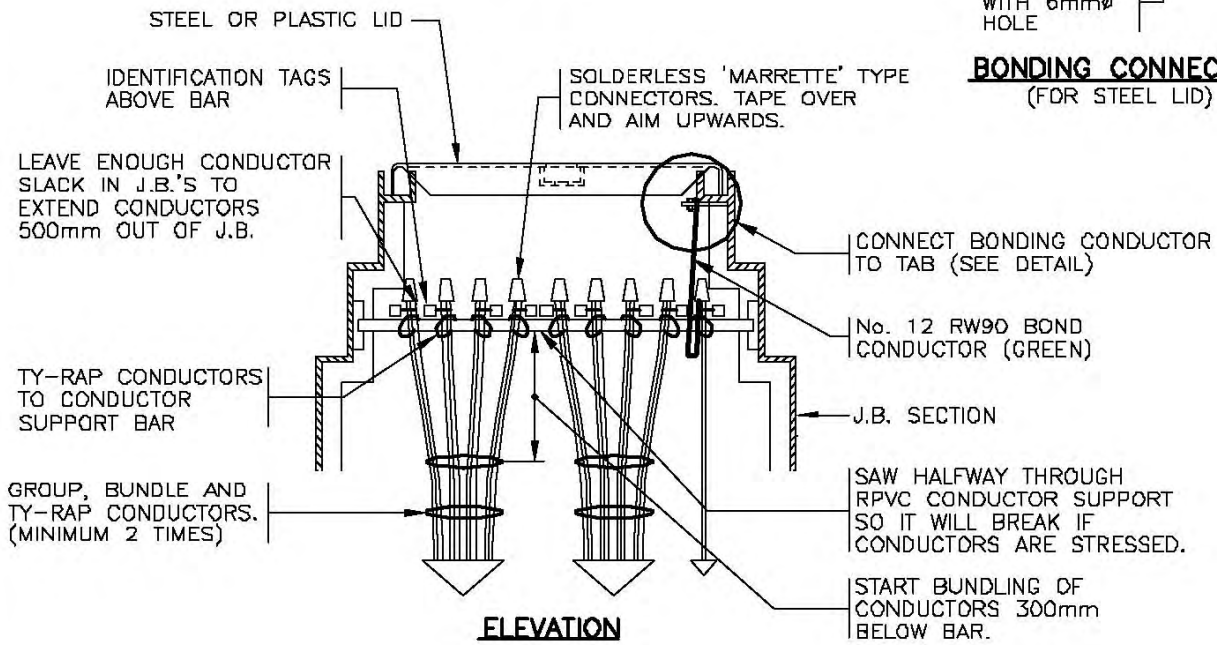

ELEVATION

NOTES

1. SEE STANDARD SPECIFICATIONS & SPECIAL PROVISIONS FOR ADDITIONAL INFORMATION.
2. GROUP, BUNDLE AND LABEL ALL CONDUCTORS SEPARATELY AS FOLLOWS:
 - DETECTOR LOOP CONDUCTORS
 - SIGNAL CONDUCTORS
 - LIGHTING & MISC. CONDUCTORS
3. IDENTIFICATION TAGS SHALL BE NEATLY MARKED WITH A BLACK INDELIBLE PEN.
4. SEE DRAWING SP635-2.5.7 FOR I.D. TAG TYPES AND DESIGNATIONS.
5. 'SN' DENOTES MINISTRY STOCK NUMBER.

aaaa

NOT TO SCALE



No.	Revision	Date
F		
E		
D		
C		
B		
A	GENERAL REVISIONS	AUG 94

WIRING INSIDE TYPES 10 TO 14 ROUND PLASTIC JUNCTION BOXES

Date **30/09/93** Approved **E.L. (Signature on File)**
Chief Highway Engineer

SPECIFICATION DRAWING No. **SP635-2.5.2**

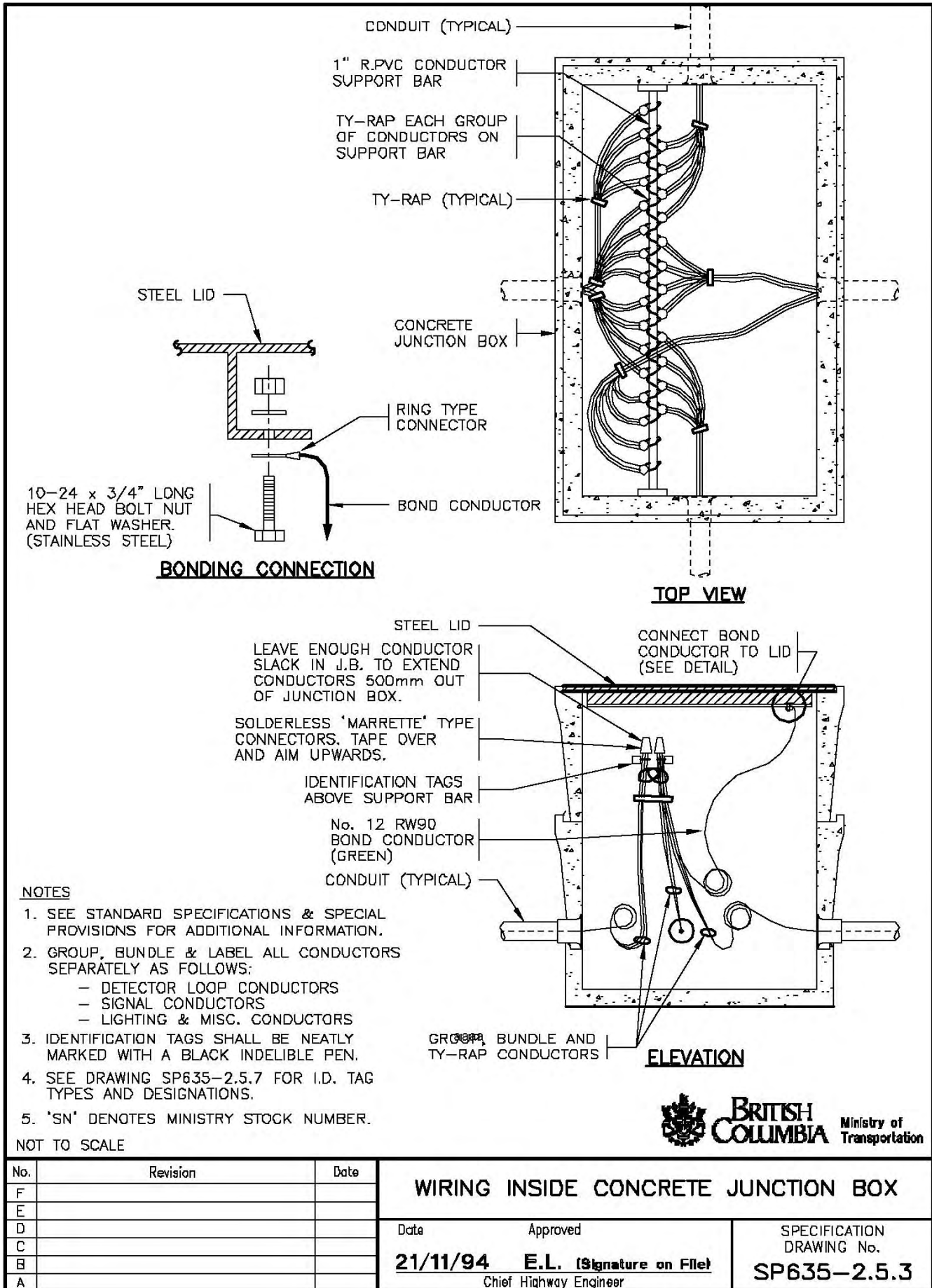

BONDING CONNECTION

TOP VIEW

ELEVATION

NOTES

1. SEE STANDARD SPECIFICATIONS & SPECIAL PROVISIONS FOR ADDITIONAL INFORMATION.
2. GROUP, BUNDLE & LABEL ALL CONDUCTORS SEPARATELY AS FOLLOWS:
 - DETECTOR LOOP CONDUCTORS
 - SIGNAL CONDUCTORS
 - LIGHTING & MISC. CONDUCTORS
3. IDENTIFICATION TAGS SHALL BE NEATLY MARKED WITH A BLACK INDELIBLE PEN.
4. SEE DRAWING SP635-2.5.7 FOR I.D. TAG TYPES AND DESIGNATIONS.
5. 'SN' DENOTES MINISTRY STOCK NUMBER.

NOT TO SCALE



No.	Revision	Date
F		
E		
D		
C		
B		
A		

WIRING INSIDE CONCRETE JUNCTION BOX

Date: **21/11/94**
 Approved: **E.L. (Signature on File)**
 Chief Highway Engineer

SPECIFICATION
 DRAWING No.
SP635-2.5.3

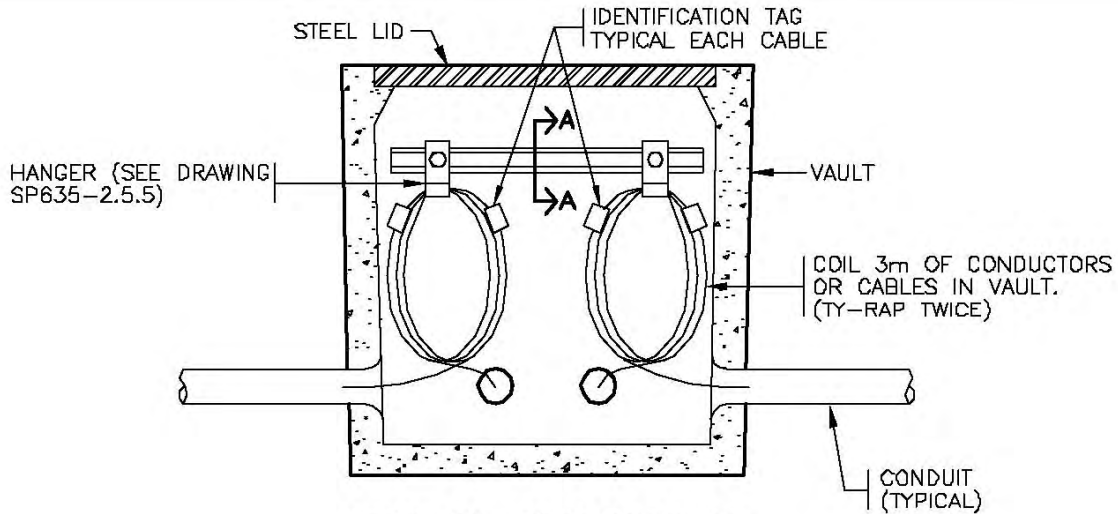

DETAIL OF CONDUCTORS OR CABLES IN VAULTS
(TYPICAL 2 SIDES OF VAULT)

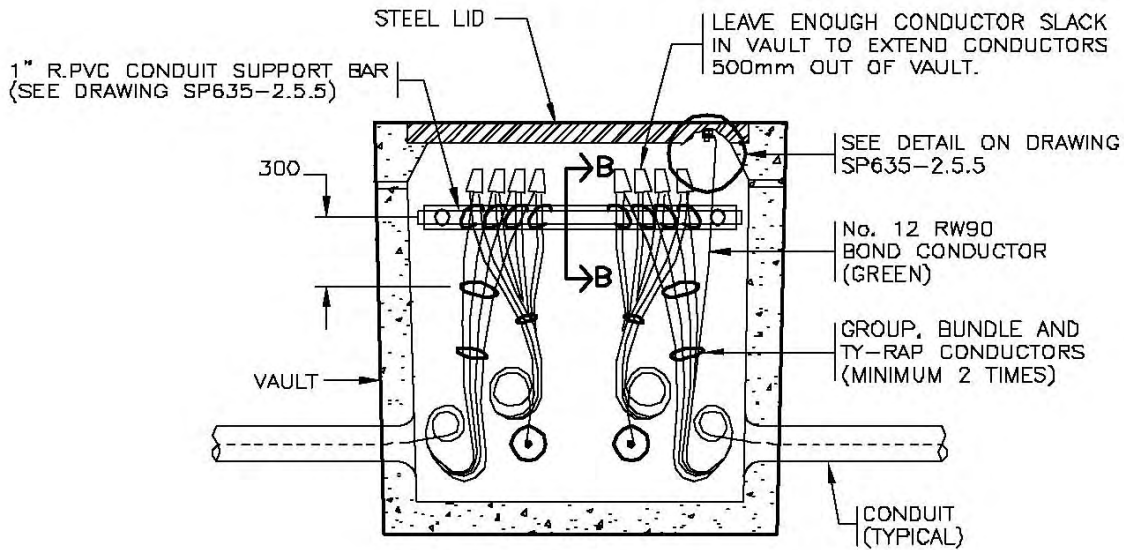

DETAIL OF CONDUCTOR SPLICES IN VAULTS
(TYPICAL 2 SIDES OF VAULT)

NOTES

1. SEE STANDARD SPECIFICATIONS & SPECIAL PROVISIONS FOR ADDITIONAL INFORMATION.
2. SEE DRAWING SP635-2.5.5 FOR ADDITIONAL NOTES AND DETAILS.
3. GROUP & BUNDLE ALL CONDUCTORS SEPARATELY AS FOLLOWS:
 - DETECTOR LOOP CONDUCTORS
 - SIGNAL CONDUCTORS
 - LIGHTING & MISC. CONDUCTORS
4. IDENTIFICATION TAGS SHALL BE NEATLY MARKED WITH A BLACK INDELIBLE PEN.
5. ALL DIMENSIONS ARE IN MILLIMETRES UNLESS OTHERWISE NOTED.
6. SEE DRAWING SP635-2.5.7 FOR I.D. TAG TYPES AND DESIGNATIONS.
7. 'SN' DENOTES MINISTRY STOCK NUMBER.

NOT TO SCALE



No.	Revision	Date
F		
E		
D		
C		
B		
A	GENERAL REVISIONS	AUG 94

WIRING INSIDE CONCRETE VAULTS		DATE	APPROVED	SPECIFICATION DRAWING No.
		30/09/93	E.L. (Signature on File) Chief Highway Engineer	SP635-2.5.4

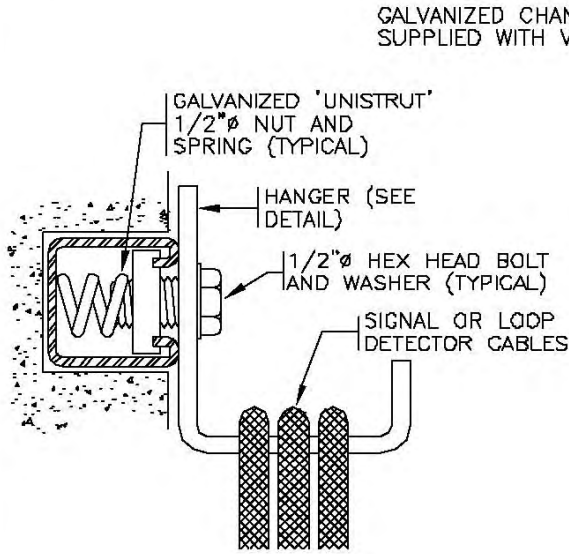

SECTION A-A

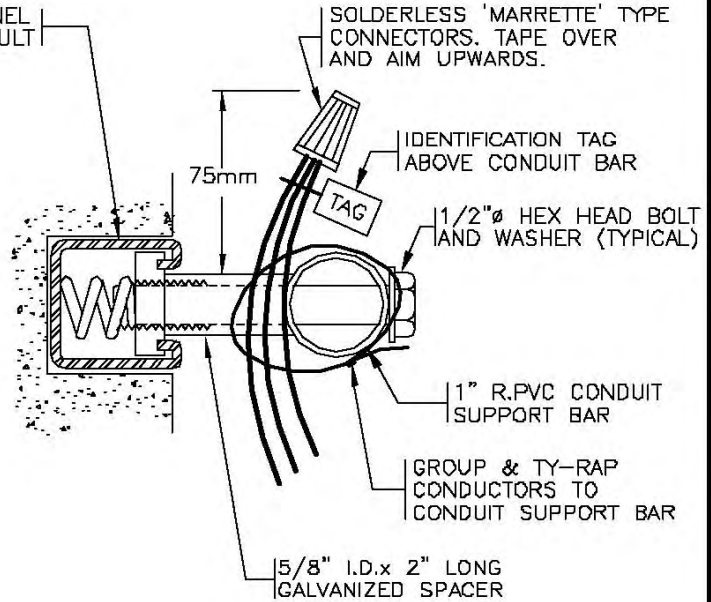

SECTION B-B

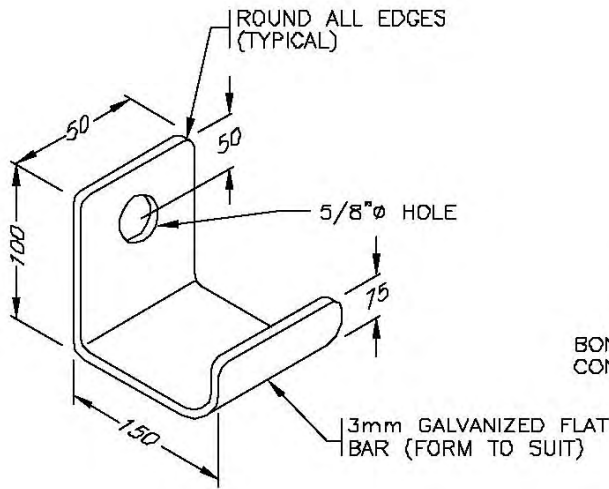

HANGER

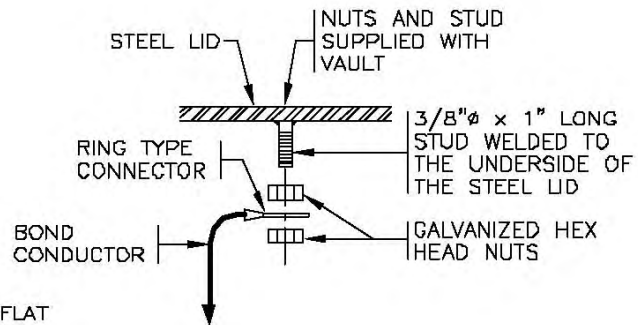

BONDING DETAIL

NOTES

1. SEE DRAWING SP635-2.5.4 FOR ADDITIONAL NOTES & DETAILS.
2. ALL BOLTS & WASHERS SHALL BE GALVANIZED.

aaaa

NOT TO SCALE



No.	Revision	Date
F		
E		
D		
C		
B		
A	GENERAL REVISIONS	AUG 94

WIRING INSIDE CONCRETE VAULTS

Date **30/09/93** Approved **E.L. (Signature on File)**
Chief Highway Engineer

SPECIFICATION DRAWING No. **SP635-2.5.5**

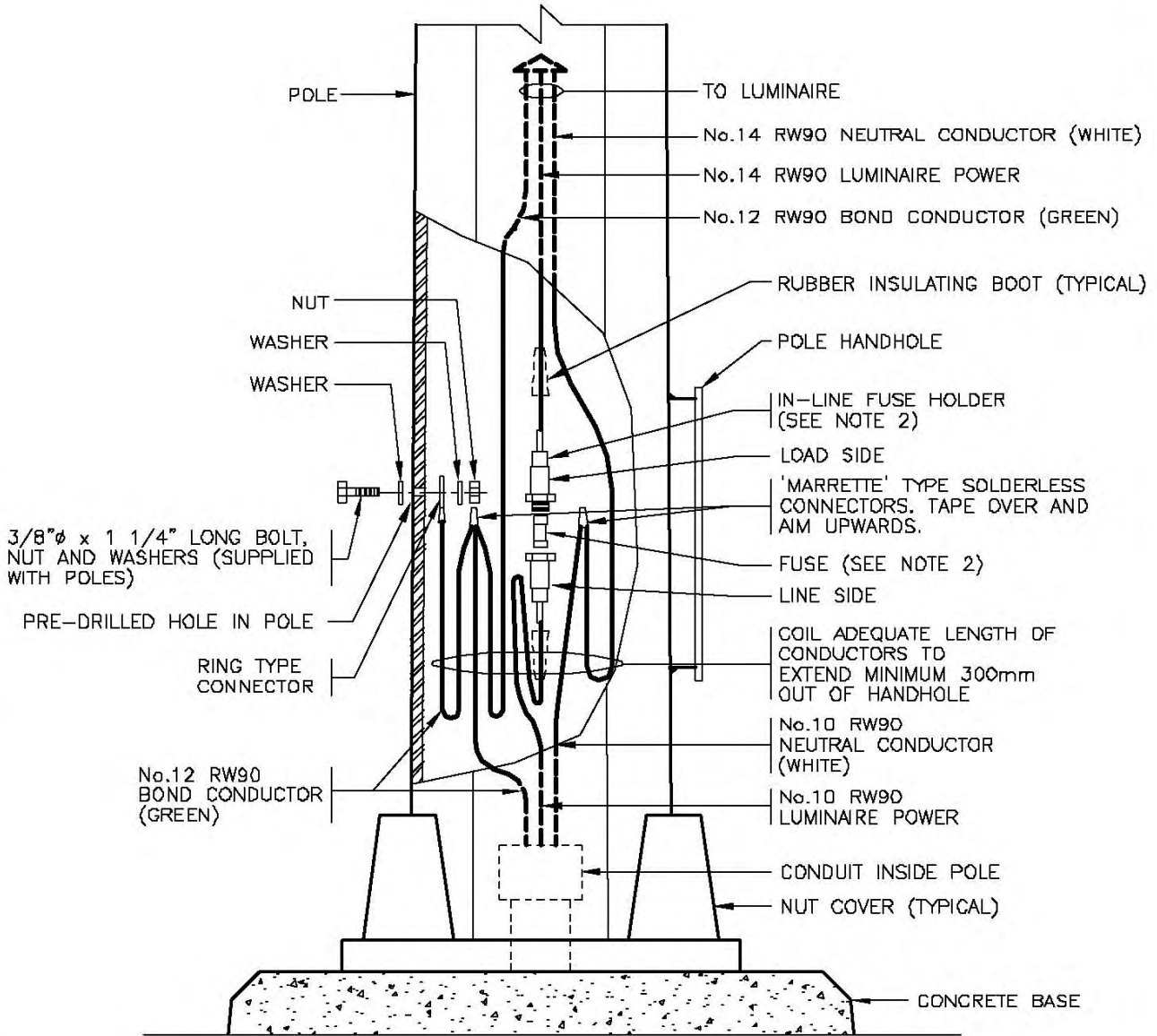

ELEVATION

NOTES

1. SEE STANDARD SPECIFICATIONS & SPECIAL PROVISIONS FOR ADDITIONAL INFORMATION.
2. IN-LINE FUSE HOLDER SHALL BE A TRON HEB-AA WEATHERPROOF FUSE HOLDER OR A GOULD SHAWMUT GEB-11-11 C/W 5A GOULD SHAWMUT ATM OR BUSS KTK FUSE (347V) OR A 10A GOULD SHAWMUT OTM OR BUSS BAN-10 FUSE (347V) AND 2 'L' TYPE INSULATING BOOTS.
3. FUSE INSTALLATION IN JUNCTION BOXES SIMILAR.
4. 'SN' DENOTES MINISTRY STOCK NUMBER.

NOT TO SCALE



No.	Revision	Date
F		
E		
D		
C	FUSEHOLDER TYPE REVISED	AUG 99
B	NOTES REVISED	AUG 95
A	GENERAL REVISIONS	AUG 94

LUMINAIRE WIRING IN POLE HANDHOLE		
Date	Approved	SPECIFICATION DRAWING No.
30/09/93	E.L. (Signature on File) Chief Highway Engineer	SP635-2.5.6

I.D. TAG DESIGNATIONS		CONDUCTOR COLOUR CODING			
ADV. WARN. FLASH. No.?	ADVANCE WARNING FLASHERS	No. 1	No. 2	No. 3	No. 4
		YELLOW	YELLOW (RD TT)	YELLOW (OR TT)	YELLOW (BL TT)
		BROWN	BROWN	BROWN	BROWN
FLASH. BEACON	FLASHING BEACON	FLASHER CONTROL TO BASE OF POLE : BLACK		BASE OF POLE TO SIGNAL HEADS : RED YELLOW	
ISLAND FLASH.	ISLAND FLASHER	ORANGE			
CONT. PWR.	CONTROLLER POWER	BLACK			
RAIL. PRE-EMPT.	RAILWAY PRE-EMPTION	2C No. 18 SHIELDED CABLE WHITE/BLACK		* SEE NOTE 3	
FIRE PRE-EMPT. No.?	FIRE PRE-EMPTION	2C No. 18 SHIELDED CABLE WHITE/BLACK		* SEE NOTE 3	
TEL	TELEPHONE	2C No. 18 SHIELDED CABLE WHITE/BLACK		* SEE NOTE 3	
LOOP No.??	DETECTOR LOOPS	2C No. 18 SHIELDED CABLE WHITE/BLACK		* SEE NOTE 3	
FIRE IND. LIGHTS	FIRE INDICATION LIGHTS	BLUE LIGHT	RED (WHITE TT)		
		WHITE LIGHT	RED		
LUM. CCTS. (A, B, ETC.)	LUMINAIRE CIRCUITS	1Ø CIRCUITS	A and C	RED	
			B and D	BLACK	
		3Ø CIRCUITS	A,D and G	RED	
			B,E and H	BLACK	
		C,F and I	BLUE		
P.E.C.	PHOTOELECTRIC CELL	SWITCH LEG	RED		
		POWER	BLACK		
—	NEUTRAL	WHITE			
—	GROUND	GREEN			

NOTES

- SEE STANDARD SPECIFICATIONS & SPECIAL PROVISIONS FOR ADDITIONAL INFORMATION.
- TT DENOTES TAPE TRACER (WH - WHITE, BL - BLUE, OR - ORANGE, RD - RED, BR - BROWN)
- EACH SHIELDED CABLE SHALL BE IDENTIFIED AT BOTH ENDS. IDENTIFICATION SHALL BE MADE USING TY-RAP IDENTIFICATION TAGS (T&B TY5532 OR APPROVED ALTERNATE) WITH THE LOOP NUMBER OR PRE-EMPTION AND PHASE TYPE CLEARLY MARKED USING A BLACK INDELIBLE MARKING PEN.
- SEE DRAWING SP635-2.8.5 FOR DETECTOR LOOP CONDUCTOR COLOUR CODING.
- SEE DRAWING SP635-2.5.8 FOR TRAFFIC SIGNAL COLOUR CODING.
- CONDUCTORS SHALL BE IDENTIFIED IN ALL J.B'S, TRAFFIC CONTROLLERS AND ALL ACCESS POINTS. IDENTIFICATION SHALL BE MADE USING TY-RAP IDENTIFICATION TAGS (T&B TY5532 OR APPROVED ALTERNATE) INDICATING SIGNAL PHASES OR PEDESTRIAN PHASES AS NOTED ON DRAWING SP635-2.5.8. TAGS SHALL BE CLEARLY MARKED WITH A BLACK INDELIBLE PEN.



No.	Revision	Date	SINGLE CONDUCTOR COLOUR CODING		
F					
E					
D			Date	Approved	SPECIFICATION DRAWING No.
C			30/09/93	E.L. (Signature on File)	SP635-2.5.7
B			Chief Highway Engineer		
A	GENERAL REVISIONS	AUG 94			

CONDUCTOR COLOUR CODING

TRAFFIC SIGNAL HEAD	SIGNAL SECTION	1	2	3 or x	4 or y
A	RED	RED	RED	RED (BL TT)	RED (BL TT)
	YELLOW	YELLOW	YELLOW (RD TT)	YELLOW	YELLOW (RD TT)
	GREEN	BLUE	BLUE	BLUE	BLUE
	YELLOW ARROW	ORANGE (WH TT)	ORANGE (WH TT)	ORANGE (WH TT)	ORANGE (WH TT)
	GREEN ARROW	BLUE (WH TT)	BLUE (WH TT)	BLUE (WH TT)	BLUE (WH TT)
B	RED	RED	RED	RED (BL TT)	RED (BL TT)
	YELLOW	BROWN	BROWN (OR TT)	BROWN	BROWN (OR TT)
	GREEN	BLUE	BLUE	BLUE	BLUE
	YELLOW ARROW	ORANGE (WH TT)	ORANGE (WH TT)	ORANGE (WH TT)	ORANGE (WH TT)
	GREEN ARROW	BLUE (WH TT)	BLUE (WH TT)	BLUE (WH TT)	BLUE (WH TT)
C	RED	RED	RED	RED (BL TT)	RED (BL TT)
	YELLOW	ORANGE	ORANGE (BL TT)	ORANGE	ORANGE (BL TT)
	GREEN	BLUE	BLUE	BLUE	BLUE
	YELLOW ARROW	ORANGE (WH TT)	ORANGE (WH TT)	ORANGE (WH TT)	ORANGE (WH TT)
	GREEN ARROW	BLUE (WH TT)	BLUE (WH TT)	BLUE (WH TT)	BLUE (WH TT)
D	RED	RED			
	YELLOW	ORANGE (RD TT)			
	GREEN	BLUE			
	YELLOW ARROW	ORANGE (WH TT)			
	GREEN ARROW	BLUE (WH TT)			
PA	DON'T WALK	YELLOW	YELLOW (RD TT)	YELLOW (OR TT)	YELLOW (BL TT)
	WALK	BLUE	BLUE	BLUE	BLUE
	PEDESTRIAN PUSHBUTTON	PURPLE (Y TT)	PURPLE (RD TT)	PURPLE (OR TT)	PURPLE (BL TT)
		PURPLE (Y TT)	PURPLE (RD TT)	PURPLE (OR TT)	PURPLE (BL TT)
PB	DON'T WALK	BROWN	BROWN (OR TT)	BROWN (RD TT)	BROWN (BL TT)
	WALK	BLUE	BLUE	BLUE	BLUE
	PEDESTRIAN PUSHBUTTON	PURPLE (BR TT)	PURPLE (OR TT)	PURPLE (RD TT)	PURPLE (BL TT)
		PURPLE (BR TT)	PURPLE (OR TT)	PURPLE (RD TT)	PURPLE (BL TT)
PC	DON'T WALK	ORANGE	ORANGE (BL TT)		
	WALK	BLUE	BLUE		
	PEDESTRIAN PUSHBUTTON	PURPLE (OR TT)	PURPLE (BL TT)		
		PURPLE (OR TT)	PURPLE (BL TT)		
PD	DON'T WALK	RED (BL TT)			
	WALK	BLUE			
	PEDESTRIAN PUSHBUTTON	PURPLE			
		PURPLE			
FS	RED	RED			
	YELLOW	YELLOW			

TT - DENOTES TRACER TAPE
 WH - WHITE
 BL - BLUE
 OR - ORANGE
 RD - RED
 BR - BROWN

NOTES:
 aaaa 1. SEE DRAWING SP635-2.5.7 FOR NOTES AND ADDITIONAL COLOUR CODING.

'FS' INDICATES 'FIRE SIGNAL' HEAD



No.	Revision	Date
F		
E		
D		
C		
B		
A	GENERAL REVISIONS	AUG 94

SINGLE CONDUCTOR COLOUR CODING

Date Approved
30/09/93 E.L. (Signature on File)
 Chief Highway Engineer

SPECIFICATION DRAWING No.
SP635-2.5.8

COLOUR CODING (MULTICONDUCTOR SIGNAL CABLE)				
19 OR 25 CONDUCTOR No. 14 (41 STRAND) CSA SPEC. No.C21.1 OR C22.2 No. 210.2-M90 CABLE				
CONDUCTOR No.	SIGNAL ASSIGNMENT	LETTERING	CONDUCTOR COLOUR	SINGLE CONDUCTOR COLOUR IN POLE
1	NEUTRAL	WHITE ONE	WHITE	WHITE
2	PRIMARY PB RETURN	WHITE TWO	WHITE	PURPLE
3	PRIMARY PB	-	BLACK	PURPLE
4	SECONDARY PB	-	ORANGE	PURPLE
5	PRIMARY RED	RED ONE	RED	RED*
6	SECONDARY RED	RED TWO	RED	RED*
7	SECONDARY PB RETURN	RED THREE	RED	PURPLE
8	PRIMARY PED DW	RED FOUR	RED	YELLOW, BROWN, ORANGE OR RED(*)
9	SECONDARY PED DW	RED FIVE	RED	YELLOW, BROWN, ORANGE OR RED(*)
10	PRIMARY YELLOW	YELLOW ONE	YELLOW	YELLOW, BROWN OR ORANGE(*)
11	SECONDARY YELLOW	YELLOW TWO	YELLOW	YELLOW, BROWN OR ORANGE(*)
12	PRIMARY LT YELLOW	YELLOW THREE	YELLOW	ORANGE(*)
13	SECONDARY LT YELLOW	YELLOW FOUR	YELLOW	ORANGE(*)
14	SECONDARY PED WALK	YELLOW FIVE	YELLOW	BLUE(*)
15	PRIMARY GREEN	GREEN ONE	BLUE	BLUE(*)
16	SECONDARY GREEN	GREEN TWO	BLUE	BLUE(*)
17	PRIMARY LT GREEN	GREEN THREE	BLUE	BLUE(*)
18	SECONDARY LT GREEN	GREEN FOUR	BLUE	BLUE(*)
19	PRIMARY PED WALK	GREEN FIVE	BLUE	BLUE(*)
20	PRIMARY LT RED	RED SIX	RED	RED (BLUE T.T.)
21	SECONDARY LT RED	RED SEVEN	RED	RED (BLUE T.T.)
22	SPARE	AMBER SIX	YELLOW	-
23	SPARE	AMBER SEVEN	YELLOW	-
24	SPARE	GREEN SIX	BLUE	-
25	SPARE	GREEN SEVEN	BLUE	-

LT = LEFT TURN SIGNAL
 DW = DON'T WALK
 PB = PEDESTRIAN PUSHBUTTON
 TT = TRACER TAPE

* YELLOW or BROWN DESIGNATIONS - YELLOW (N/B & S/B) BROWN - (E/B & W/B)

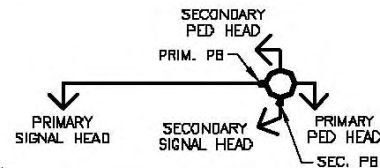

(*) SEE NOTE 3

NOTES

- SEE STANDARD SPECIFICATIONS & SPECIAL PROVISIONS FOR ADDITIONAL INFORMATION.
- 19 CONDUCTOR CABLE TO BE USED EXCEPT WHERE EXTRA CONDUCTORS ARE REQUIRED (IE; PROTECTED LEFT TURNS ON SIGNAL ARMS).
- COLOUR CODING AND TRACER TAPE INSIDE POLES SHALL BE IN ACCORDANCE WITH SP635-2.5.7 & 2.5.8.



No.	Revision	Date
F		
E		
D		
C		
B		
A		

SIGNAL CABLE WIRING & COLOUR CODING

Date: 14/11/03
 Approved: D.N. (Signature on File)
 Chief Engineer

SPECIFICATION DRAWING No. SP635-2.5.9

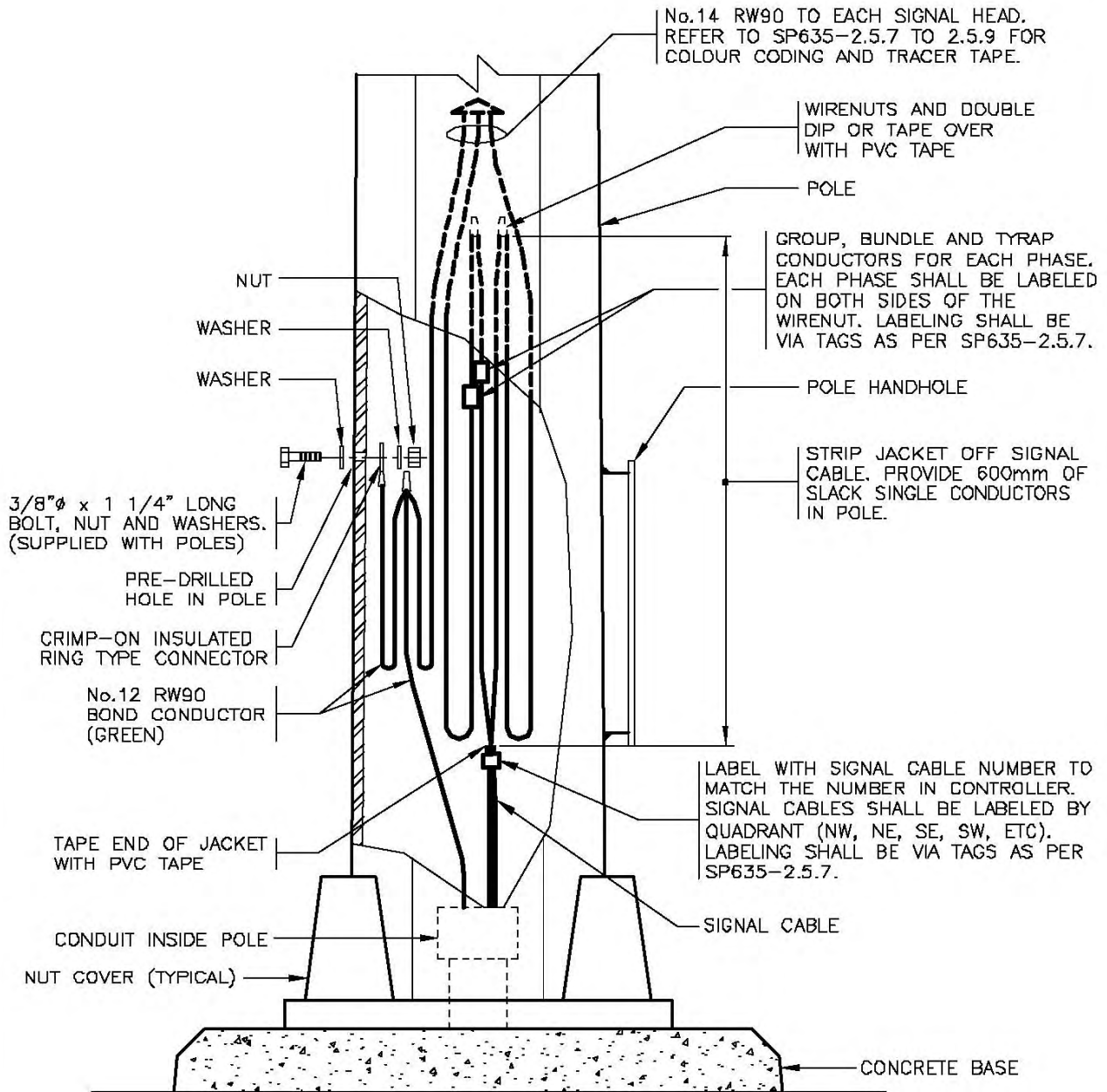

ELEVATION

NOTES

1. SEE STANDARD SPECIFICATIONS & SPECIAL PROVISIONS FOR ADDITIONAL INFORMATION.
2. 'SN' DENOTES MINISTRY STOCK NUMBER.
3. REFER TO SP635-2.5.7 FOR CONDUCTOR LABELING.

NOT TO SCALE



No.	Revision	Date
F		
E		
D		
C		
B		
A		

SIGNAL CABLE WIRING IN POLE HANDHOLE

Date **14/11/03** Approved **D.N. (Signature on File)**
Chief Engineer

SPECIFICATION DRAWING No. **SP635-2.5.10**

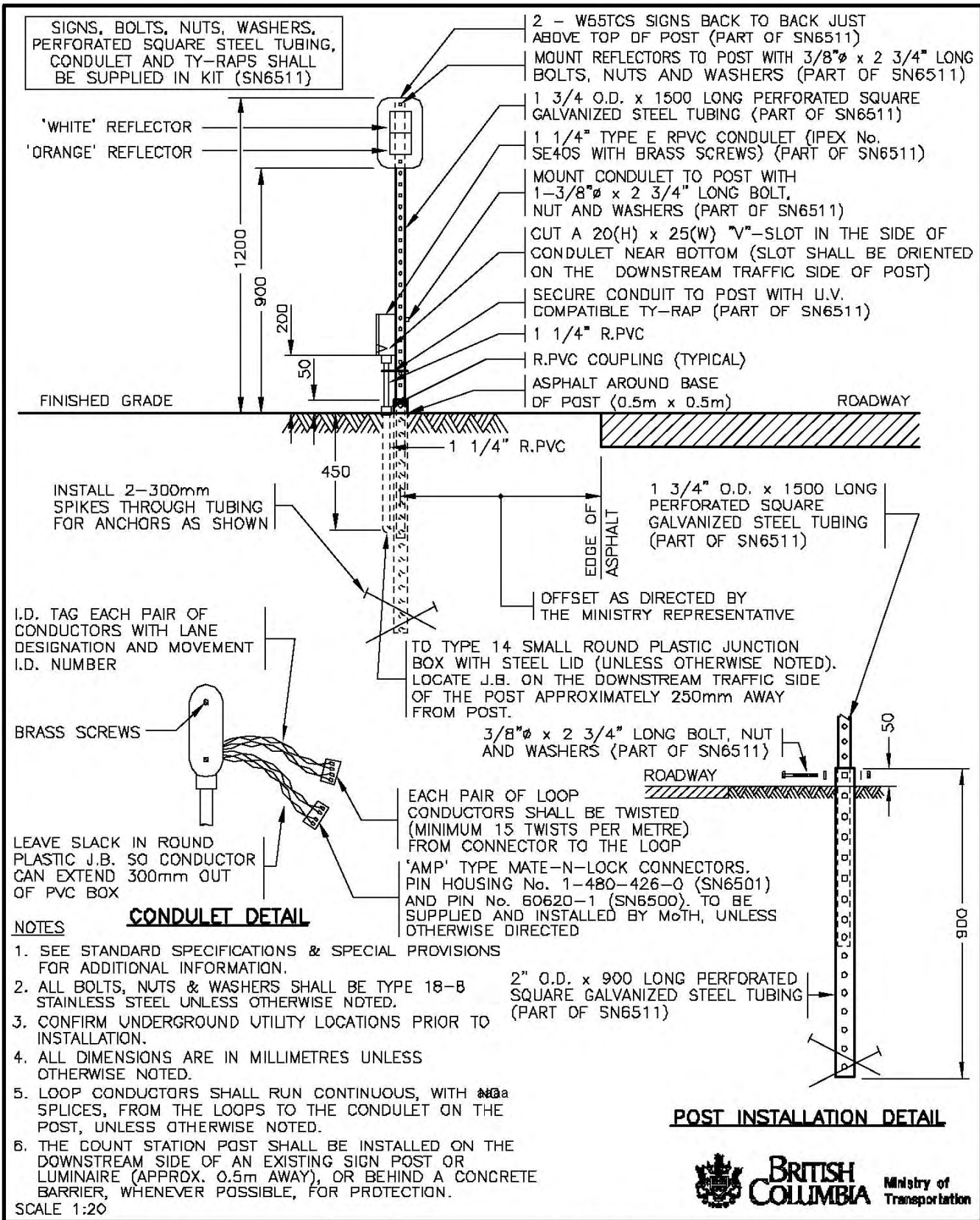

- NOTES**
- SEE STANDARD SPECIFICATIONS & SPECIAL PROVISIONS FOR ADDITIONAL INFORMATION.
 - ALL BOLTS, NUTS & WASHERS SHALL BE TYPE 18-8 STAINLESS STEEL UNLESS OTHERWISE NOTED.
 - CONFIRM UNDERGROUND UTILITY LOCATIONS PRIOR TO INSTALLATION.
 - ALL DIMENSIONS ARE IN MILLIMETRES UNLESS OTHERWISE NOTED.
 - LOOP CONDUCTORS SHALL RUN CONTINUOUS, WITH ~~at~~ SPLICES, FROM THE LOOPS TO THE CONDULET ON THE POST, UNLESS OTHERWISE NOTED.
 - THE COUNT STATION POST SHALL BE INSTALLED ON THE DOWNSTREAM SIDE OF AN EXISTING SIGN POST OR LUMINAIRE (APPROX. 0.5m AWAY), OR BEHIND A CONCRETE BARRIER, WHENEVER POSSIBLE, FOR PROTECTION.
- SCALE 1:20



No.	Revision	Date
G	COLD PATCH ADDED & UPPER SPIKES REMOVED	NOV 01
F	GENERAL REVISIONS	SEPT 00
E	NOTE 6 ADDED	AUG 99
D	KIT NOTE ADDED, NOTES REVISED	NOV 98
C	GENERAL REVISIONS & ANCHOR SPIKES ADDED	AUG 96
B	CONDULET MOUNTING & CONDUIT BURY REVISED	AUG 95

SHORT COUNT STATION INSTALLATION DETAILS		SPECIFICATION DRAWING No.
Date	Approved	SP635-2.6.1
30/09/93	E.L. (Signature on File) Chief Highway Engineer	

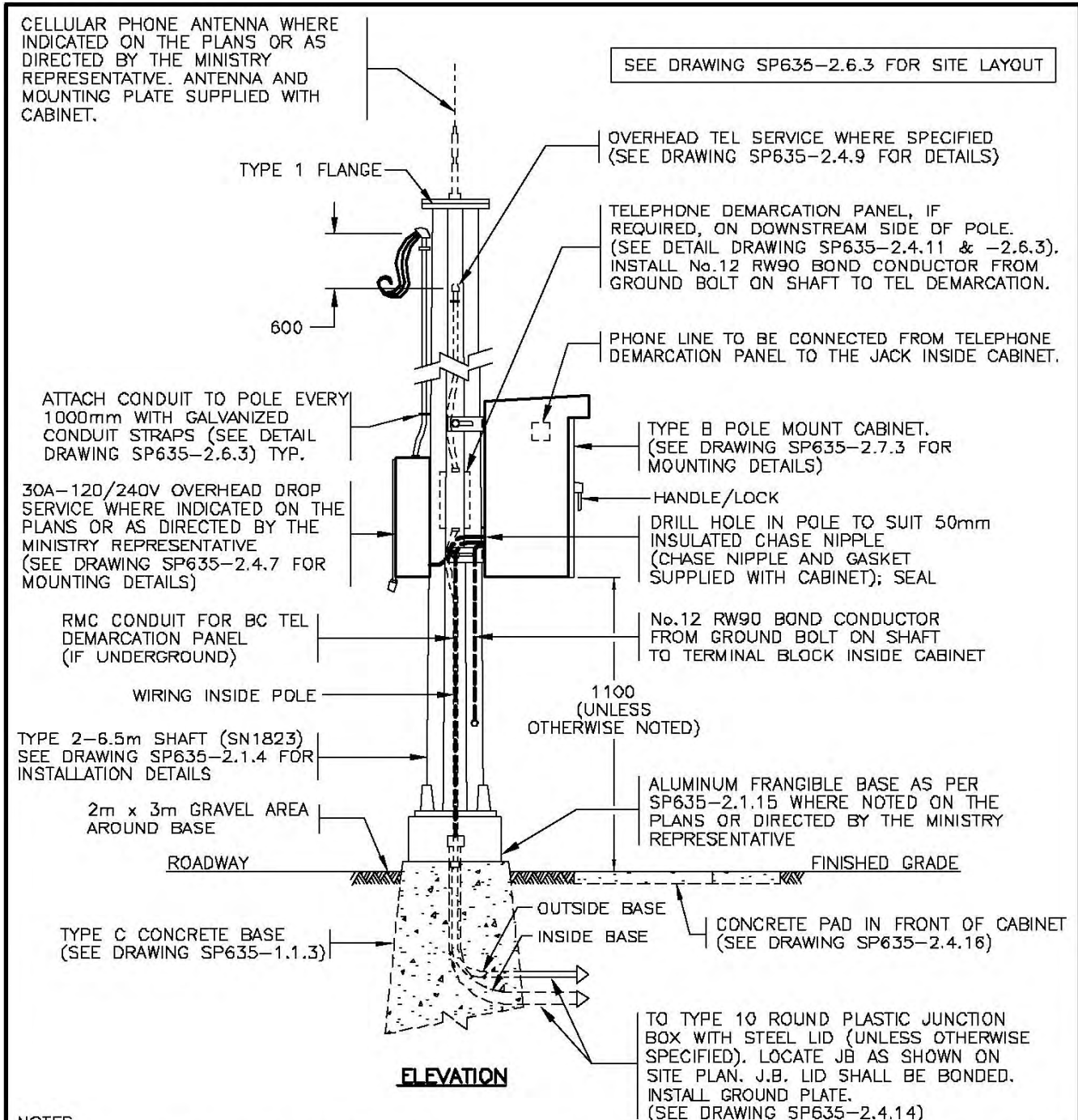

- NOTES**
- SEE STANDARD SPECIFICATIONS & SPECIAL PROVISIONS FOR ADDITIONAL INFORMATION.
 - CONTRACTOR TO CONFIRM ORIENTATION OF CABINET WITH THE MINISTRY REPRESENTATIVE PRIOR TO INSTALLATION.
 - ALL DIMENSIONS ARE IN MILLIMETRES UNLESS OTHERWISE NOTED.
 - CABINET SHALL BE SUPPLIED BY THE MINISTRY.
 - 2m OF LOOP WIRE AND/OR SHIELDED CABLE SHALL BE COILED IN THE CABINET FOR CONNECTIONS BY MINISTRY. TAG AND LABEL CABLES IN ACCORDANCE WITH DRAWING SP635-2.5.7. THE CABINET LOOP OPENING SHALL BE DUCT-SEALED ONCE WIRING IS PULLED THRU.
- SCALE: 1:25



No.	Revision	Date	PERMANENT COUNT STATION INSTALLATION DETAILS		SPECIFICATION DRAWING No. SP635-2.6.2
F			Date	Approved	
E			30/09/93	E.L. (Signature on File) Chief Highway Engineer	
D	GENERAL REVISIONS	SEPT 00			
C	TEL DEMARCATION PANEL RELOCATED	AUG 99			
B	TEL DEMARCATION & CONCRETE PADS SHOWN	NOV 98			
A	O/H TEL & POWER SERVICES ADDED	OCT 97			

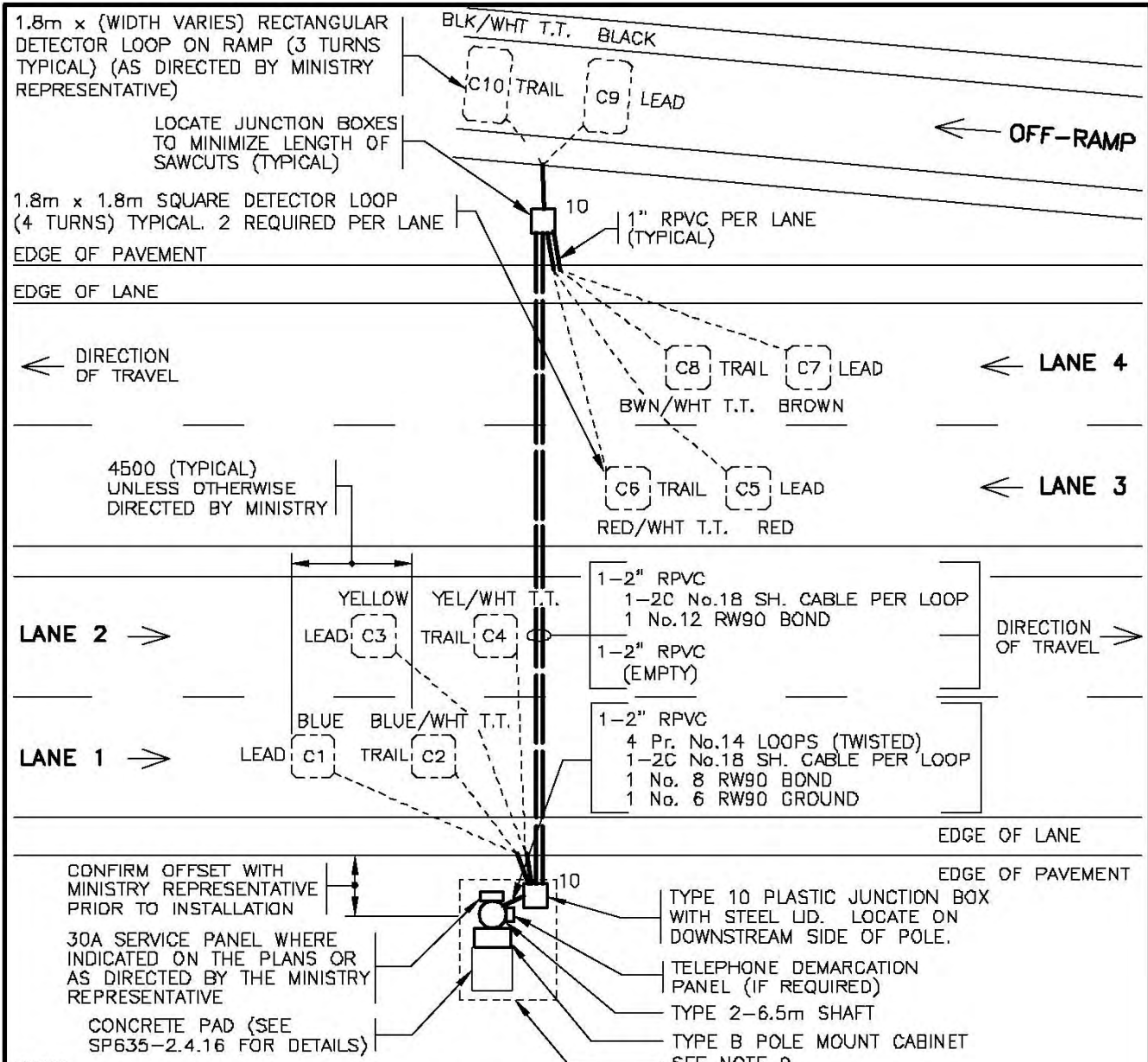

NOTES

1. SEE STANDARD SPECIFICATIONS & SPECIAL PROVISIONS FOR ADDITIONAL INFORMATION.
2. CONTRACTOR TO CONFIRM ORIENTATION OF CABINET AND SITE PLAN LAYOUT WITH THE MINISTRY REPRESENTATIVE PRIOR TO INSTALLATION.
3. FOR LOCATIONS WITH 4 OR MORE LANES, 1-2C No.18 SHIELDED CABLE REQUIRED FOR EACH DETECTOR LOOP IN THE LANES FURTHEST FROM CABINET. SPLICING TO SHIELDED CABLE IS NOT REQUIRED IN 2 OR 3 LANE LOCATIONS UNLESS OTHERWISE DIRECTED BY THE MINISTRY REPRESENTATIVE.
4. 1-25mm RPVC LOOP CONDUIT REQUIRED PER LANE.
5. LOOPS SHALL BE NUMBERED SEQUENTIALLY FROM CABINET SIDE OUT.
6. LOOPS SHALL BE CUT 4500mm FROM LEADING EDGE OF THE LEADING LOOP TO THE LEADING EDGE OF THE TRAILING LOOP PER LANE, UNLESS OTHERWISE DIRECTED BY THE MINISTRY.
7. LOCATE LOOPS IN CENTRE OF LANES UNLESS OTHERWISE NOTED ON THE PLANS OR DIRECTED BY MINISTRY REPRESENTATIVE.
8. AFTER INSTALLATION IS COMPLETE, THE CONTRACTOR SHALL PROVIDE A SKETCH SHOWING EXACT SIZE OF LOOPS AND SPACINGS. SKETCH AND LOOP CHECK SHEETS SHALL BE SUBMITTED TO THE MINISTRY REPRESENTATIVE.
9. EXCAVATE 2m x 3m AREA AROUND POLE AND FILL WITH CRUSH TO 300mm ABOVE GRADE WITH TAPERED EDGES.

SEE DRAWING SP635-2.6.2 FOR POLE ELEVATION



No.	Revision	Date
F		
E		
D	GRAVEL CHANGED TO CRUSH IN NOTE 9	NOV 01
C	CONDUIT CROSSING & NOTES REVISED	SEPT 00
B	LOOP LAYOUT REVISED	AUG 99
A	LOOP LAYOUT REVISED	NOV 98

SITE PLAN AND LOOP LAYOUT FOR PERMANENT COUNT STATIONS		
Date	Approved	SPECIFICATION DRAWING No.
18/02/98	D.M. (Signature on File) Chief Highway Engineer	SP635-2.6.3

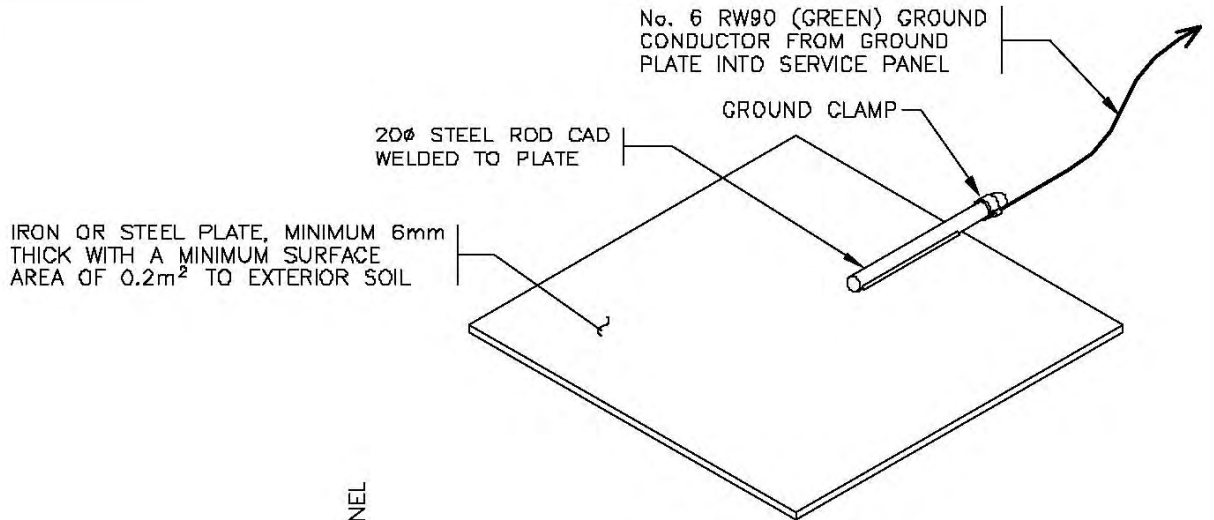

GROUND PLATE

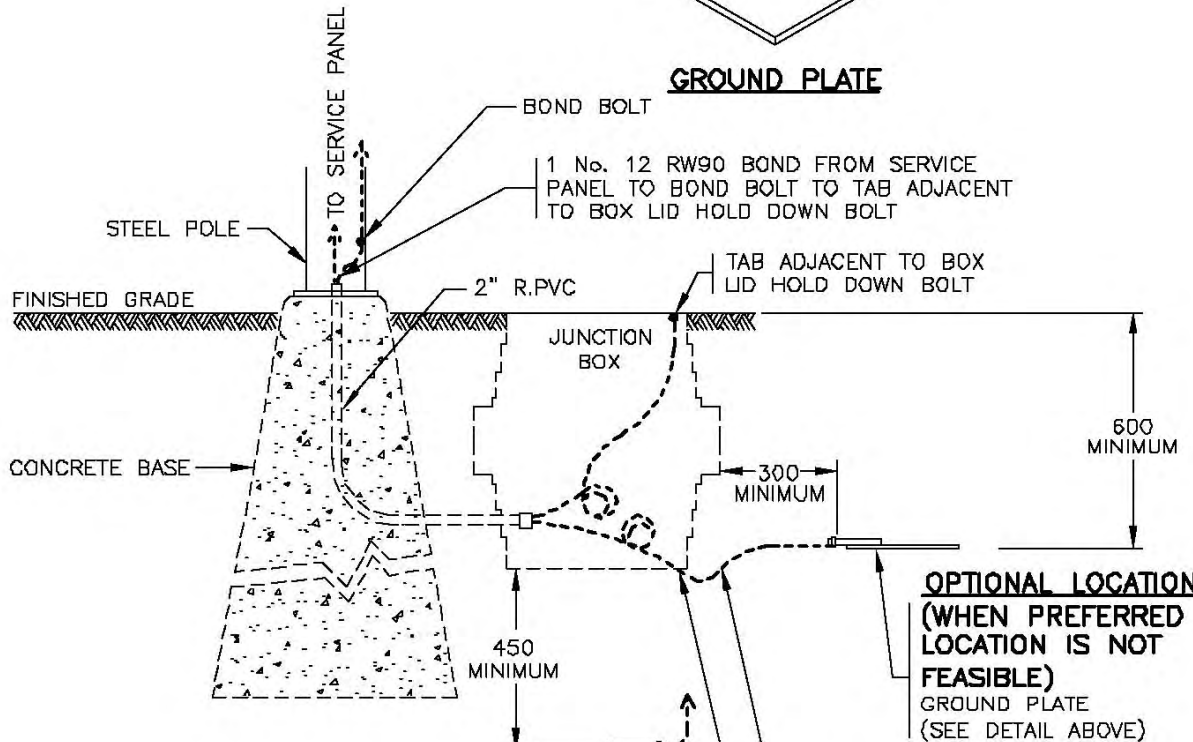

ELEVATION

NOTES

1. SEE STANDARD SPECIFICATIONS & SPECIAL PROVISIONS FOR ADDITIONAL INFORMATION.
2. ALL DIMENSIONS ARE IN MILLIMETRES UNLESS OTHERWISE NOTED.
3. GROUND PLATE SHALL BE INSTALLED IN UNDISTURBED MOIST SOILS. DEPTH AND LOCATION OF GROUND PLATE SHALL VARY TO PROVIDE OPTIMAL SOIL CONDITIONS FOR GROUNDING.
4. GROUND RESISTANCE READING SHALL BE 25 OHMS OR LESS.

NOT TO SCALE



No.	Revision	Date
F		
E		
D		
C		
B		
A	DRAWING TITLE CHANGE	OCT 03

GROUND PLATE INSTALLATION DETAIL FOR COUNT STATIONS

Date	Approved	SPECIFICATION DRAWING No.
	Chief Highway Engineer	SP635-2.6.4

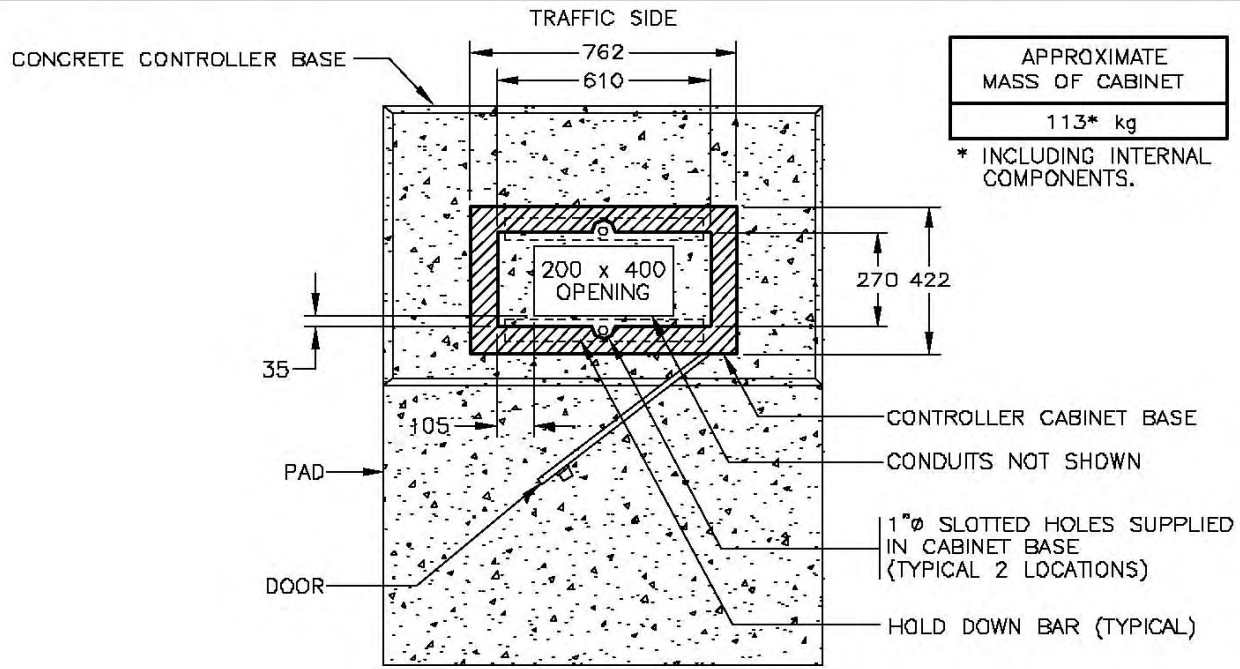

SECTION A

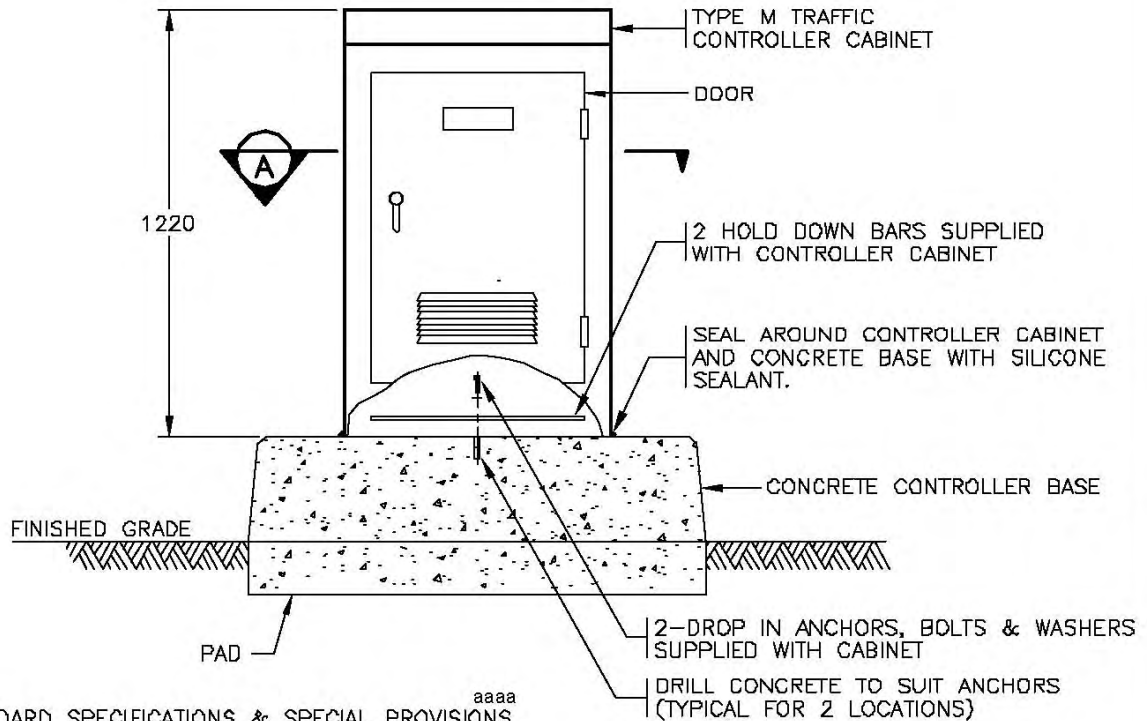

NOTES

1. SEE STANDARD SPECIFICATIONS & SPECIAL PROVISIONS FOR ADDITIONAL INFORMATION.
2. ALL DIMENSIONS ARE IN MILLIMETRES UNLESS OTHERWISE NOTED.

NOT TO SCALE



No.	Revision	Date
F		
E		
D		
C		
B		
A	GENERAL REVISIONS	AUG 94

TYPE M CONTROLLER CABINET
INSTALLATION DETAILS

Date: 30/09/93
Approved: E.L. (Signature on File)
Chief Highway Engineer

SPECIFICATION DRAWING No.
SP635-2.7.1

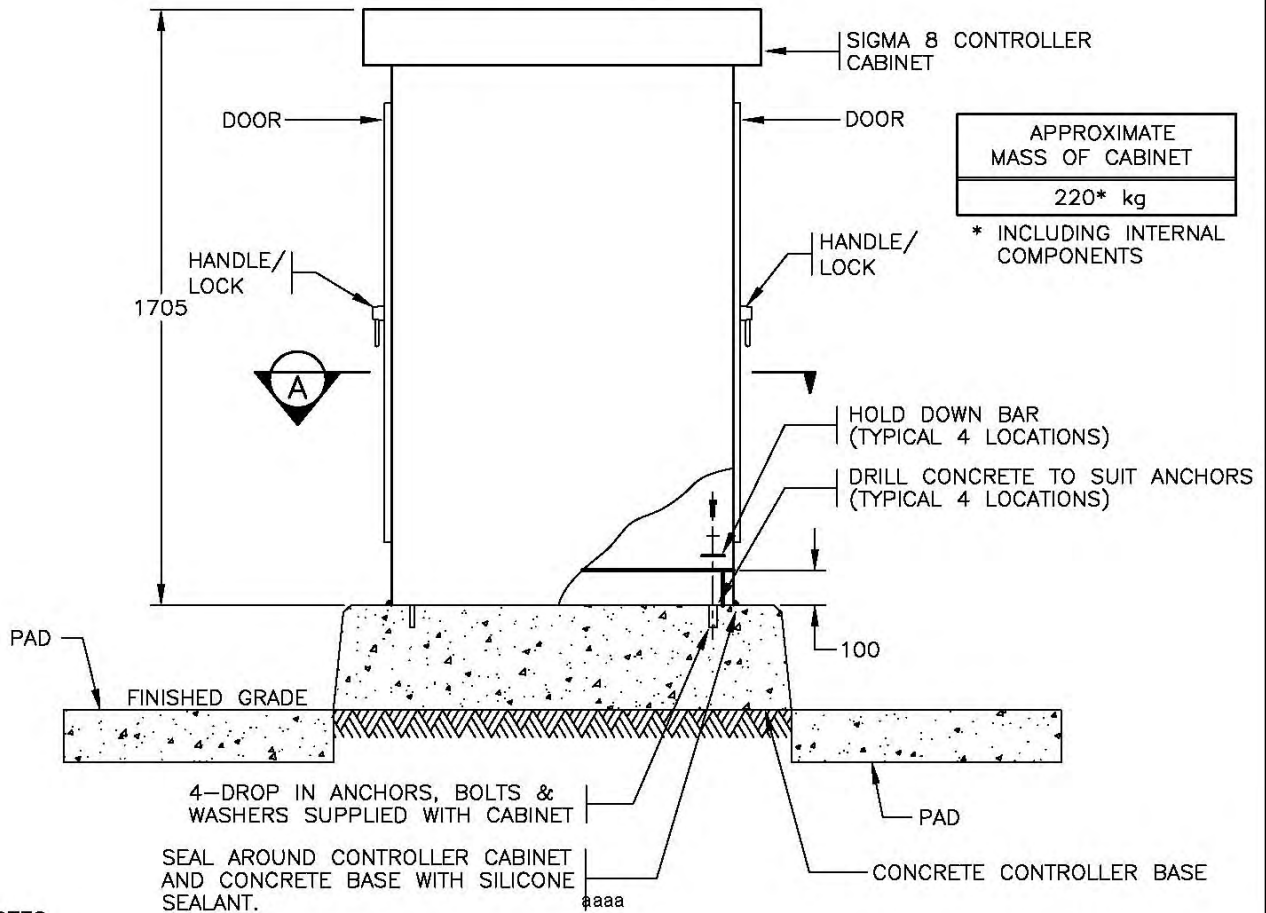
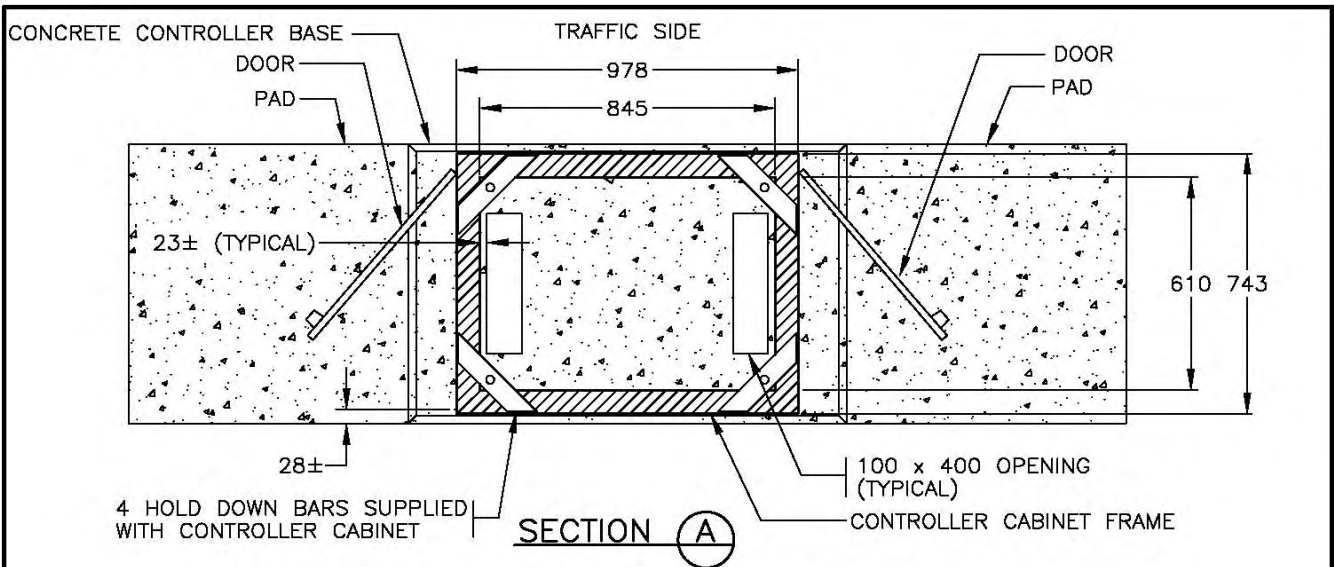

APPROXIMATE MASS OF CABINET
220* kg

* INCLUDING INTERNAL COMPONENTS

NOTES

1. SEE STANDARD SPECIFICATIONS & SPECIAL PROVISIONS FOR ADDITIONAL INFORMATION.
2. ALL DIMENSIONS ARE IN MILLIMETRES UNLESS OTHERWISE NOTED.

NOT TO SCALE



No.	Revision	Date	TYPE S CONTROLLER CABINET INSTALLATION DETAILS	
F			Date	Approved
E			30/09/93	E.L. (Signature on File)
D			Chief Highway Engineer	
C			SPECIFICATION DRAWING No.	
B			SP635-2.7.2	
A	GENERAL REVISIONS	AUG 94		

CABINET TYPE	HEIGHT	WIDTH	DEPTH	APPROXIMATE MASS
B	883	556	406	37 kg
C	1040	556	406	56 kg

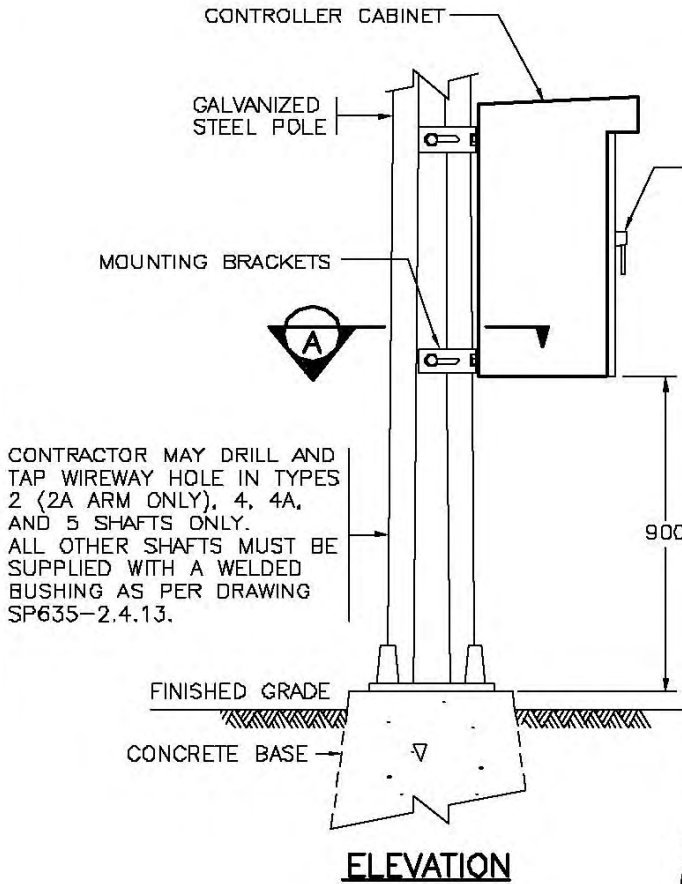

NOTES

1. SEE STANDARD SPECIFICATIONS & SPECIAL PROVISIONS FOR ADDITIONAL INFORMATION.
2. ORIENTATION OF CABINET SHALL BE CONFIRMED BY THE MINISTRY ELECTRICAL REPRESENTATIVE PRIOR TO INSTALLATION.
3. ALL DIMENSIONS ARE IN MILLIMETRES UNLESS OTHERWISE NOTED.

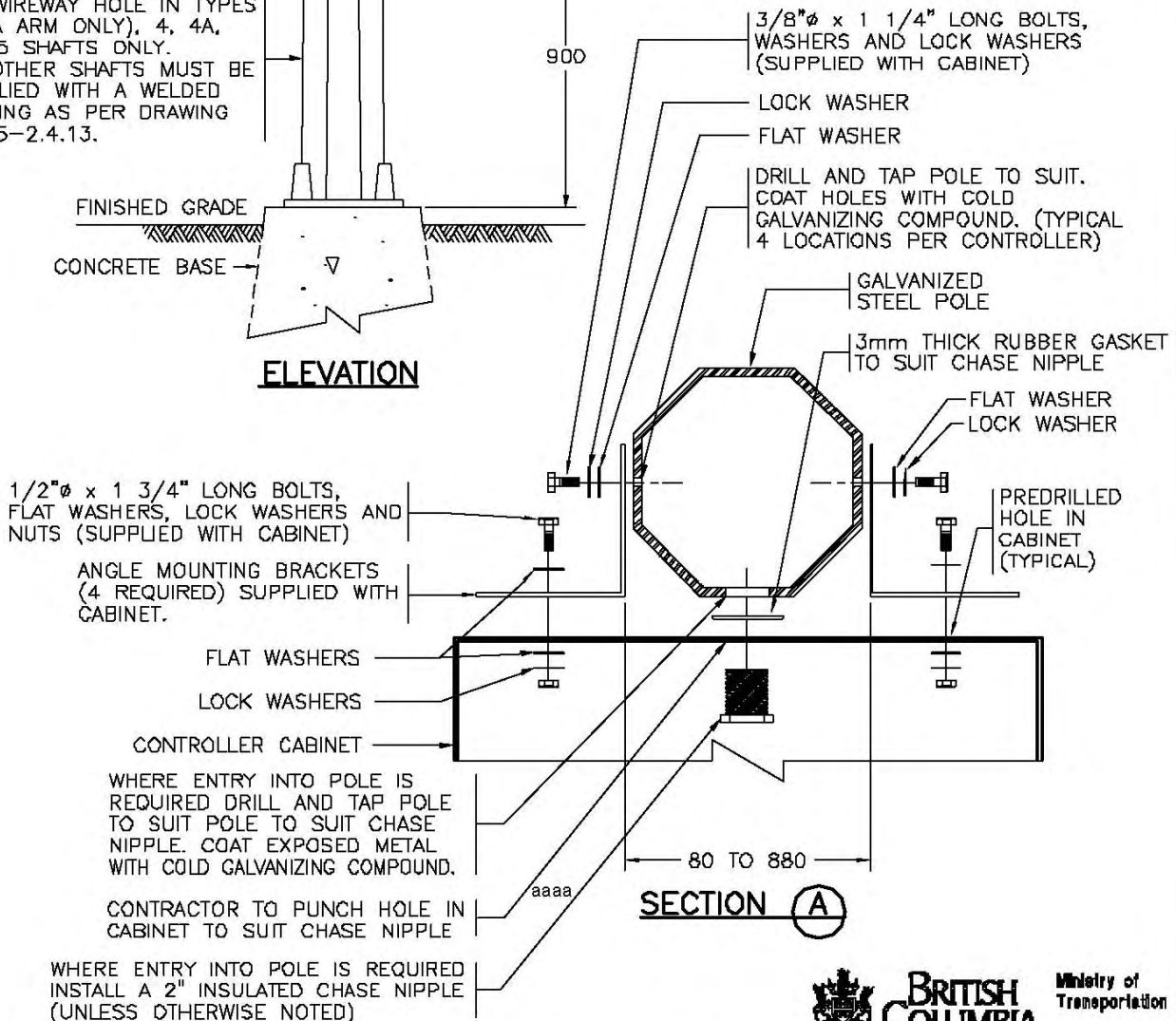

NOT TO SCALE



No.	Revision	Date
F		
E		
D		
C	TYPE G CABINET DELETED	OCT 03
B	MOUNTING HEIGHT REVISED	OCT 97
A	GENERAL REVISIONS	AUG 94

TYPES B AND C CONTROLLER CABINET INSTALLATION DETAILS

Date: **30/09/93** Approved: **E.L. (Signature on File)**
Chief Highway Engineer

SPECIFICATION DRAWING No. **SP635-2.7.3**

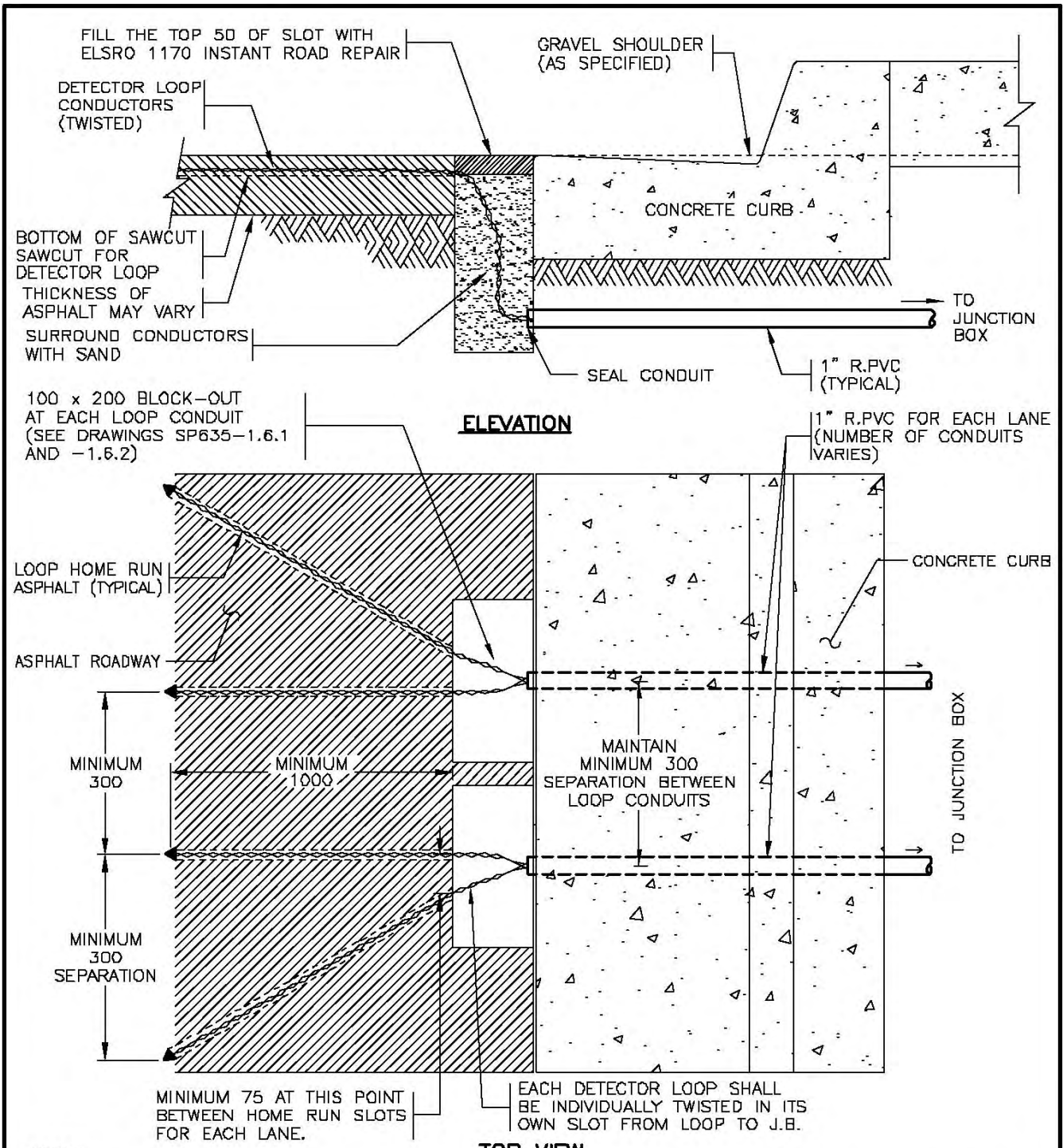

NOTES

1. SEE STANDARD SPECIFICATIONS & SPECIAL PROVISIONS FOR ADDITIONAL INFORMATION.
2. SEE DRAWING SP635-2.8.6 FOR LOOP COLOR CODING.
3. SEE DRAWING SP635-1.6.1 & 1.6.2 FOR LOOP CONDUIT INSTALLATION DETAILS.
4. ALL DIMENSIONS ARE IN MILLIMETRES UNLESS OTHERWISE NOTED.



NOT TO SCALE

No.	Revision	Date
F		
E		
D		
C		
B	REFERENCED DWG. No. REV'D (NOTE 2)	DEC 98
A	SPELLING REVISION	AUG 96

DETECTOR LOOP INSTALLATION DETAILS

Date	Approved	SPECIFICATION DRAWING No.
15/11/95	M.C. (Signature on File) Chief Highway Engineer	SP635-2.8.1

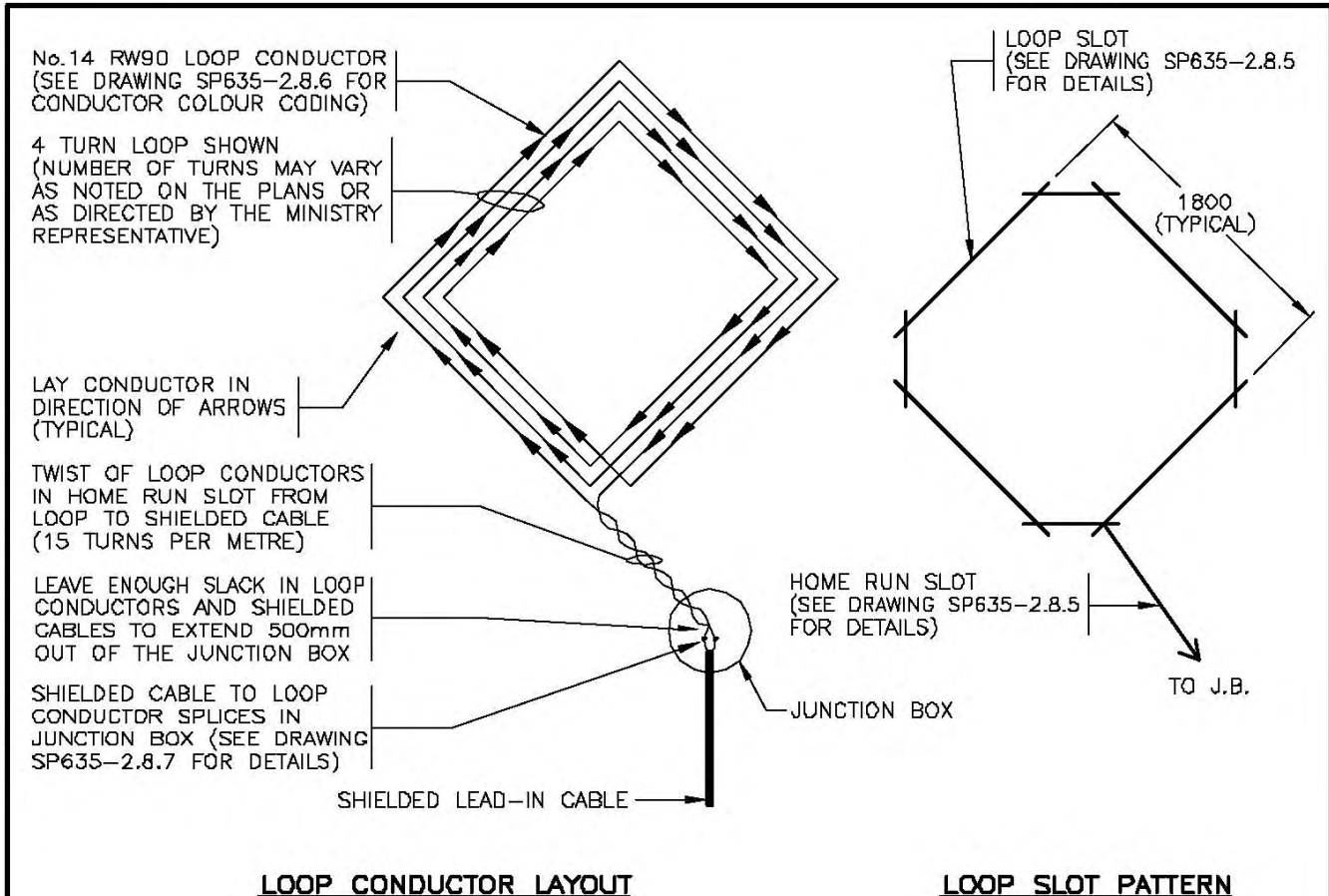

LOOP CONDUCTOR LAYOUT

LOOP SLOT PATTERN

NOTES

1. SEE STANDARD SPECIFICATIONS & SPECIAL PROVISIONS FOR ADDITIONAL INFORMATION.
2. ALL DIMENSIONS ARE IN MILLIMETRES UNLESS OTHERWISE NOTED.
3. LOOP CONDUCTORS SHALL BE INSTALLED IN THE SAWCUT SLOT.
4. LOOP INSTALLATION PROCEDURES & RULES SHALL BE FOLLOWED IN ACCORDANCE WITH DRAWINGS SP635-2.8.8 AND -2.8.9.
5. ALL DIAMOND DETECTOR LOOPS SHALL BE 4 TURN UNLESS OTHERWISE NOTED.
6. DIAMOND LOOPS SHALL NOT BE USED FOR SHORT DURATION OR PERMANENT TRAFFIC COUNTER STATION INSTALLATIONS.

aaaa

LOOP INDUCTANCE TABLE (μH) (LESS SHIELDED LEAD-IN CABLE INDUCTANCE)	
TURNS	INDUCTANCE
4	120 μH
5	180 μH
6	252 μH
7	336 μH

LOOP INDUCTANCE SHALL BE GREATER THAN THE SHIELDED CABLE INDUCTANCE. (A 2:1 RATIO IS PREFERABLE). SHIELDED CABLE INDUCTANCE IS 0.56 μH PER METRE FOR 18 AWG WIRE.

NOT TO SCALE



No.	Revision	Date
F		
E		
D		
C		
B	SHIELDED CABLE WIRE SIZE NOTED, NOTE 6 ADDED	NOV 98
A	SHIELDED CABLE INDUCTANCE REVISED	AUG 96

DIAMOND DETECTOR LOOP INSTALLATION DETAILS		
Date	Approved	SPECIFICATION DRAWING No.
15/11/95	M.C. (Signature on File) Chief Highway Engineer	SP635-2.8.2

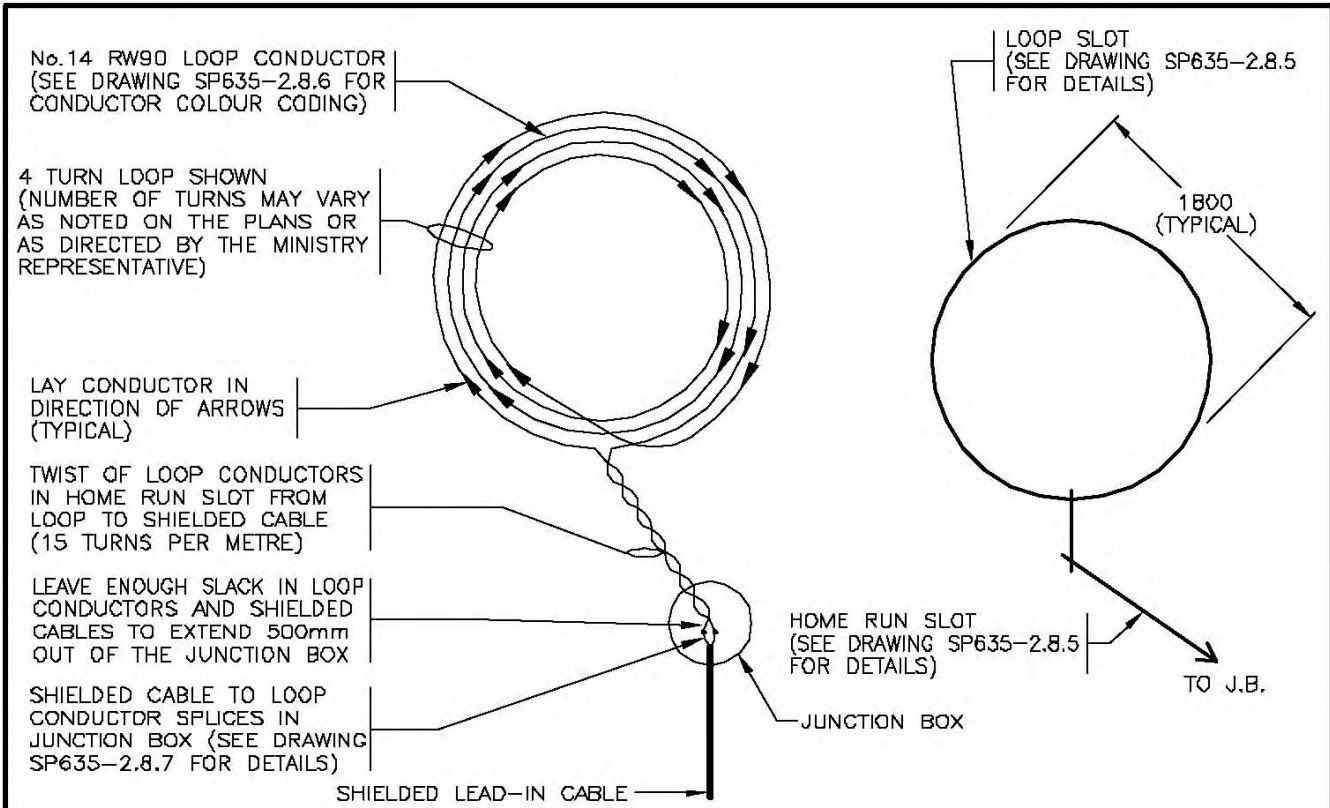

LOOP CONDUCTOR LAYOUT

LOOP SLOT PATTERN

NOTES

1. SEE STANDARD SPECIFICATIONS & SPECIAL PROVISIONS FOR ADDITIONAL INFORMATION.
2. ALL DIMENSIONS ARE IN MILLIMETRES UNLESS OTHERWISE NOTED.
3. LOOP CONDUCTORS SHALL BE INSTALLED IN THE SAWCUT SLOT.
4. LOOP INSTALLATION PROCEDURES & RULES SHALL BE FOLLOWED IN ACCORDANCE WITH DRAWINGS SP635-2.8.8 AND -2.8.9.
5. ALL ROUND DETECTOR LOOPS SHALL BE 4 TURN UNLESS OTHERWISE NOTED.
6. ROUND LOOPS SHALL NOT BE USED FOR SHORT DURATION OR PERMANENT TRAFFIC COUNTER STATION INSTALLATIONS.

aaaa

LOOP INDUCTANCE TABLE (μH) (LESS SHIELDED LEAD-IN CABLE INDUCTANCE)	
TURNS	INDUCTANCE
4	95 μH
5	140 μH
6	195 μH
7	260 μH

LOOP INDUCTANCE SHALL BE GREATER THAN THE SHIELDED CABLE INDUCTANCE. (A 2:1 RATIO IS PREFERABLE). SHIELDED CABLE INDUCTANCE IS 0.56 μH PER METRE FOR 18 AWG WIRE.

NOT TO SCALE



No.	Revision	Date
F		
E		
D		
C		
B		
A	ALTERNATE NOTE REMOVED	OCT 03

ROUND DETECTOR LOOP INSTALLATION DETAILS		
Date	Approved	SPECIFICATION DRAWING No.
30/09/93	E.L. (Signature on File) Chief Highway Engineer	SP635-2.8.3

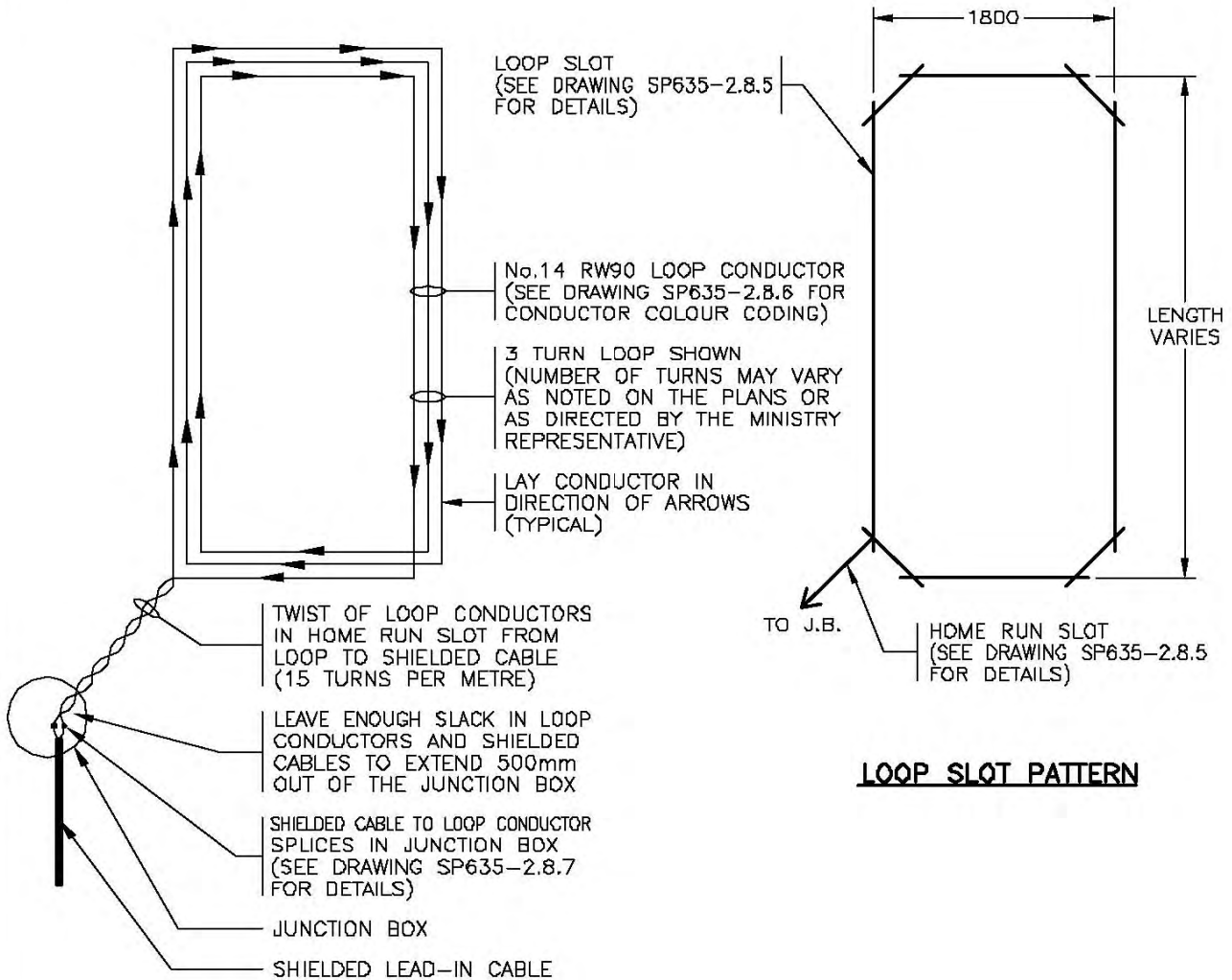

LOOP CONDUCTOR LAYOUT

LOOP SLOT PATTERN

NOTES

1. SEE STANDARD SPECIFICATIONS & SPECIAL PROVISIONS FOR ADDITIONAL INFORMATION.
2. ALL DIMENSIONS ARE IN MILLIMETRES UNLESS OTHERWISE NOTED.
3. LOOP CONDUCTORS SHALL BE INSTALLED IN THE SLOTTED SAWCUT.
4. LOOP INSTALLATION PROCEDURES & RULES SHALL BE FOLLOWED IN ACCORDANCE WITH DRAWINGS SP635-2.8.8 AND -2.8.9.
5. ALL RECTANGULAR DETECTOR LOOPS SHALL BE 3 TURN UNLESS OTHERWISE NOTED.

LOOP INDUCTANCE FORMULA (μH)
(LESS SHIELDED LEAD-IN CABLE INDUCTANCE)

$$L = P/4 (3.28)(N^2 + N)$$

L = LOOP INDUCTANCE (μH)
 P = PERIMETER (METRES)
 N = NUMBER OF TURNS

LOOP INDUCTANCE SHALL BE GREATER THAN THE SHIELDED CABLE INDUCTANCE. (A 2:1 RATIO IS PREFERABLE). SHIELDED CABLE INDUCTANCE IS 0.56 μH PER METRE FOR 18 AWG WIRE.

aaaa

NOT TO SCALE



No.	Revision	Date
E		
D		
C		
B	DRAWING NUMBER CHANGED & SHIELDED CABLE WIRE SIZE NOTED	NOV 98
A	SHIELDED CABLE INDUCTANCE REVISED	AUG 96

RECTANGULAR DETECTOR LOOP INSTALLATION DETAILS		
Date	Approved	SPECIFICATION DRAWING No.
15/11/95	M.C. (Signature on File) Chief Highway Engineer	SP635-2.8.4

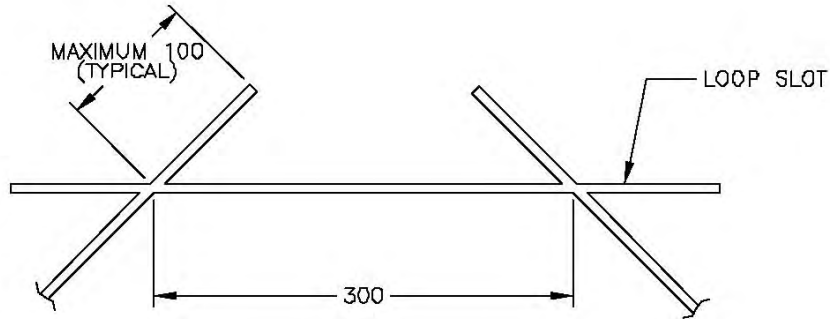

TYPICAL LOOP CORNER DETAIL
(FOR DIAMOND & RECTANGULAR LOOPS)

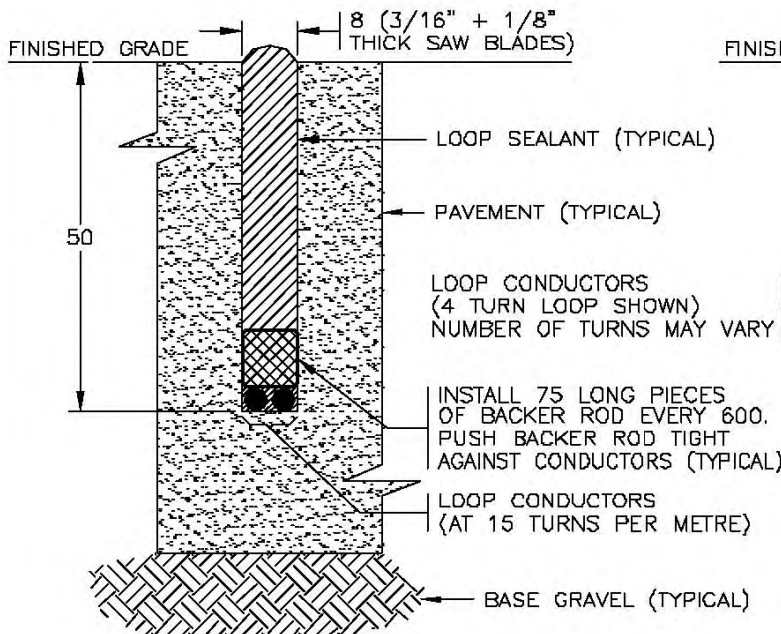

HOME RUN SLOT

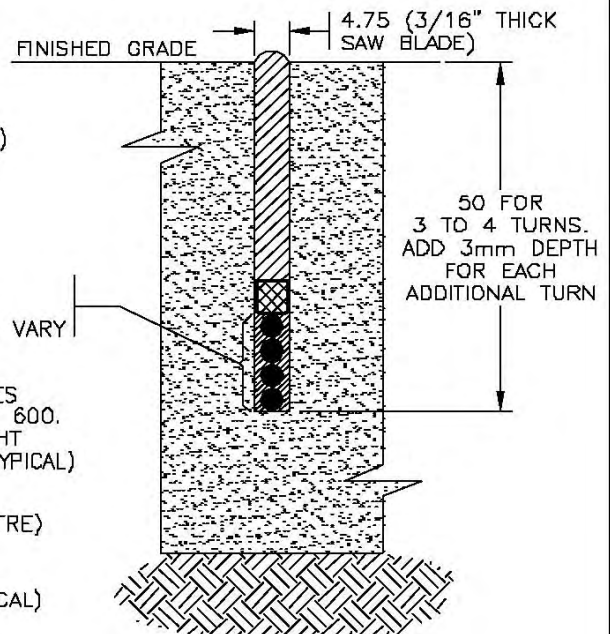

LOOP SLOT

NOTES

1. SEE STANDARD SPECIFICATIONS & SPECIAL PROVISIONS FOR ADDITIONAL INFORMATION.
2. ALL DIMENSIONS ARE IN MILLIMETRES.
3. APPROVED LOOP SLOT SEALANTS ARE ELSRO HOT POUR CRACK FILLER No. 1190, BURFALT 16607 170, TYPE 2 DR LEFRENZ SYSTEM 400. ALTERNATE PRODUCTS MUST MEET MINISTRY APPROVAL.
4. APPROVED BACKER RODS ARE DETECTOR SYSTEMS BR-625. ALTERNATE PRODUCTS MUST MEET MINISTRY APPROVAL.
5. ONLY ONE LOOP SHALL BE INSTALLED IN EACH HOME RUN SLOT.

NOT TO SCALE



No.	Revision	Date
F		
E		
D		
C		
B	APPROVED SEALER ADDED	AUG 99
A	DRAWING NUMBER CHANGED	NOV 98

LOOP AND HOME RUN SLOT DETAILS

Date: **15/11/95**
 Approved: **M.C. (Signature on File)**
 Chief Highway Engineer

SPECIFICATION
 DRAWING No.
SP635-2.8.5

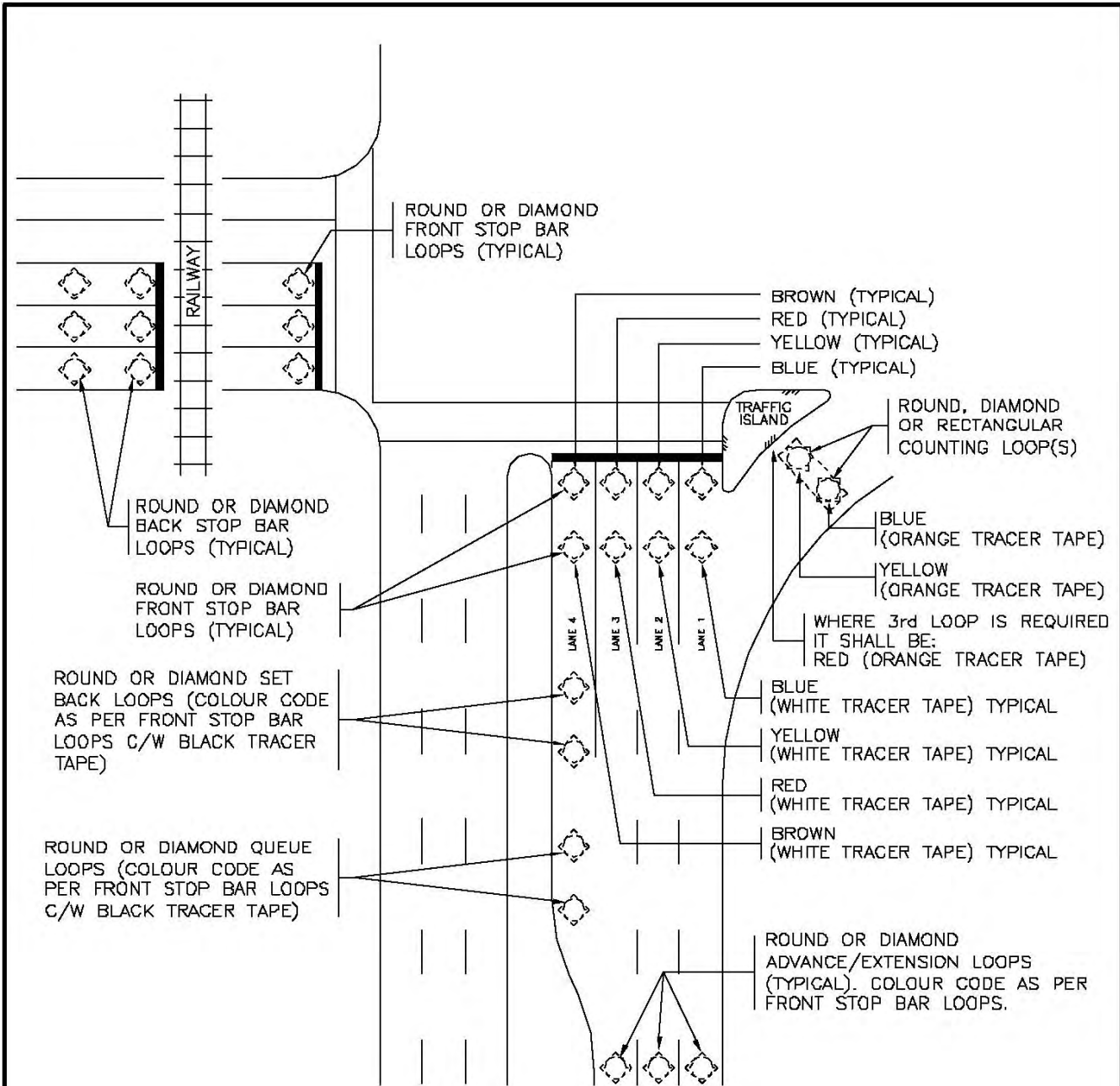

DETECTOR LOOPS

NOTES

1. SEE STANDARD SPECIFICATIONS & SPECIAL PROVISIONS FOR ADDITIONAL INFORMATION
2. COLOUR CODE IS BASED ON USING RIGHT HAND ^{aaaa} CURB OF ROAD AS POINT OF REFERENCE & WORKING LOOP CONDUCTORS LEFT TOWARDS CENTRE OF ROADWAY. WHERE A 5th LANE, USE ORANGE CONDUCTOR COLOUR.
3. RECTANGULAR DETECTOR LOOP CONDUCTORS SHALL BE BLACK.

NOT TO SCALE



No.	Revision	Date	DETECTOR LOOP TYPES COLOUR CODING	
E			Date	Approved
D				
C				
B	SETBACK, QUEUE & ADVANCE LOOPS ADDED	SEPT 00	15/11/95	M.C. (Signature on File) Chief Highway Engineer
A	DRAWING NUMBER CHANGED, ROUND LOOPS ADDED	NOV 98		SPECIFICATION DRAWING No. SP635-2.8.6

STEP 1. STRIP LOOP WIRES AND LEAD-IN CABLE AND SLIDE ON HEAT SHRINKS

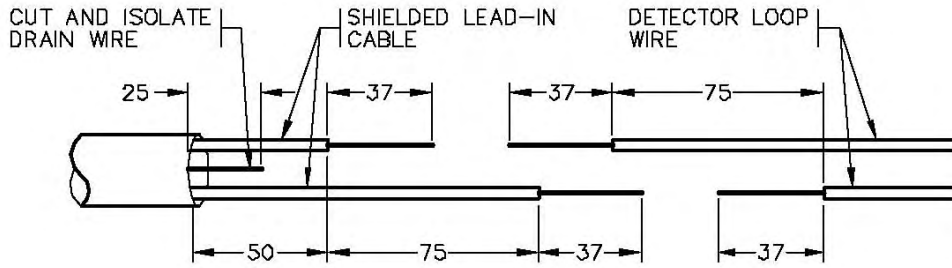

STEP 2. CONNECT AND SOLDER. TWIST BARE CONDUCTORS TOGETHER AND SOLDER WITH 60/40 (TIN/LEAD) RESIN SOLDER.

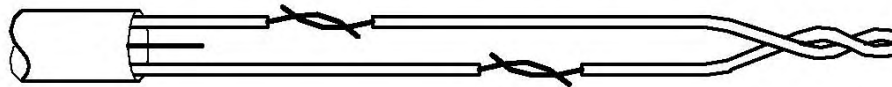

STEP 3. INSULATE EACH SOLDER JOINT SEPARATELY

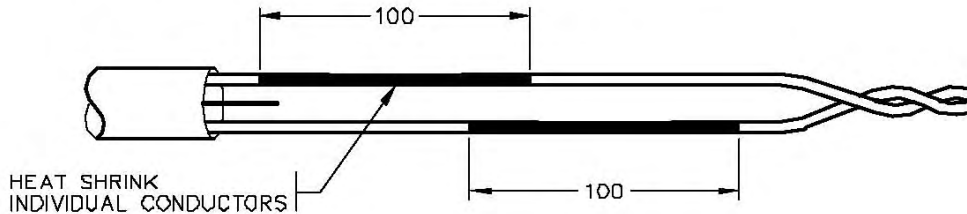

STEP 4. ENVIRONMENTALLY SEAL TOTAL SPLICE.

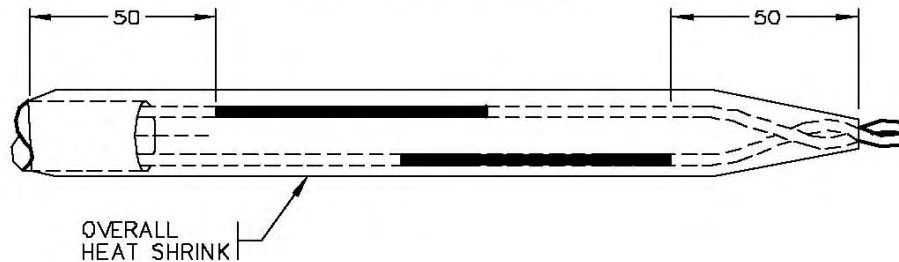

NOTES

1. SEE STANDARD SPECIFICATIONS & SPECIAL PROVISIONS FOR ADDITIONAL INFORMATION. aaaa
2. ALL DIMENSIONS ARE IN MILLIMETRES.
3. HEAT SHRINK SHALL BE PREMIER CLEAR-SEAL (1/4" I.D. INDIVIDUAL CONDUCTORS & 3/8" I.D. FOR OVERALL) OR APPROVED ALTERNATE.

NOT TO SCALE



No.	Revision	Date
F		
E		
D		
C		
B		
A	DRAWING NUMBER CHANGED	NOV 98

DETECTOR LOOP TO SHIELDED CABLE SPLICING DETAILS

Date **15/11/95** Approved **M.C. (Signature on File)**
 Chief Highway Engineer

SPECIFICATION DRAWING No. **SP635-2.8.7**

STEP BY STEP LOOP INSTALLATION PROCEDURES AND RULES ARE AS FOLLOWS:

STEP 1 CONFIRM THE TYPE OF LOOP TO BE INSTALLED (i.e. DIAMOND ROUND OR RECTANGULAR). LOOP TYPES ARE DETAILED ON DRAWINGS SP635-2.8.2 to -2.8.4.

STEP 2 LAYOUT DETECTOR LOOPS AND REVIEW LOCATIONS WITH THE MINISTRY ELECTRICAL REPRESENTATIVE PRIOR TO SAWCUTTING THE ROADWAY. THE GENERAL LAYOUT OF THE DETECTOR LOOPS IS INDICATED ON DRAWINGS SP635-2.8.11 to -2.8.14. STOP BARS AND LANE LINES MUST BE LAID OUT PRIOR TO LOCATING DETECTOR LOOPS.

RULE 1 DETECTOR LOOPS SHALL NOT BE INSTALLED WHEN THE ROAD IS WET OR WHEN THE AMBIENT (AIR) TEMPERATURE IS LOWER THAN 5°C, UNLESS APPROVED IN WRITING BY THE MINISTRY ELECTRICAL REPRESENTATIVE. SEALANTS DO NOT ADHERE PROPERLY IN WET CONDITIONS. SHOULD THE CONTRACTOR BE ASKED IN WRITING BY THE MINISTRY ELECTRICAL REPRESENTATIVE TO INSTALL LOOPS IN THE WET AND/OR WHEN THE AIR TEMPERATURE IS BELOW 5°C, THE INSTALLATION WARRANTY WILL NOT BE ENFORCED.

RULE 2 DETECTOR LOOPS SHALL NOT BE INSTALLED WHEN THE PAVEMENT IS CRACKED OR BADLY RUTTED UNLESS THE INSTALLATION IS APPROVED IN WRITING BY THE MINISTRY ELECTRICAL REPRESENTATIVE. SAW CUTS CAN OFTEN CAUSE PAVEMENT CONDITIONS TO DETERIORATE FURTHER. IF RE-SURFACING OF THE INTERSECTION IS NOT PLANNED THEN PHOTOGRAPHS SHOULD BE TAKEN TO DOCUMENT THE PAVEMENT CONDITIONS BEFORE AND AFTER THE LOOP INSTALLATION. PHOTOGRAPHS SHALL BE LABELED WITH THE LOOP NUMBERS AND THEN SUBMITTED TO THE THE MINISTRY ELECTRICAL REPRESENTATIVE AFTER THE INSTALLATION IS COMPLETED.

STEP 3 CUT LOOP AND HOME RUN SLOTS IN ASPHALT. ALL LOOP AND HOME RUN SLOTS SHALL BE CUT TO THE SAME DEPTH, WITH A PAVEMENT SAW. SLOTS SHALL NOT PASS THROUGH PAVEMENT INTO THE BASE GRAVEL.

RULE 3 LOOP AND HOME RUN SLOT MUST BE INSTALLED AT LEAST 300mm FROM ANY OTHER LOOP AND EACH LEAD-IN SLOTS, EXCEPT WHERE THE LEAD-IN CONDUCTORS ENTER THE 1" RPVC CONDUIT. THIS WILL REDUCE THE PROBABILITY OF INTERFERENCE BETWEEN LOOPS.

RULE 4 WHEN REPLACING LOOPS, CUT THROUGH TWICE ON EACH SIDE OF EXISTING LOOP. THIS MAY REQUIRE ADDITIONAL SAW CUTS; IF THE EXISTING LOOP IS NOT LOCATED IN THE SAW CUT PATH OF THE NEW LOOP, THIS WILL ELIMINATE THE POSSIBILITY OF INTERFERENCE BETWEEN THE OLD AND THE NEW LOOP.

STEP 4 CLEAN THE SLOT WITH A PROFESSIONAL GRADE PRESSURIZED WATER SYSTEM. REMOVE ALL WATER AND DIRT OUT OF THE SLOT CUT AND THE SURROUNDING 100mm OF ROAD SURFACE USING COMPRESSED AIR. SLOT MUST REMAIN COMPLETELY CLEAN AND DRY UNTIL THE SLOT IS SEALED.

STEP 5 INSTALL THE LOOP CONDUCTOR INTO THE LOOP SLOT. ENSURE CONDUCTORS ARE TIGHTLY WOUND AND PUSHED INTO THE BOTTOM OF THE SLOT. TWIST CONDUCTOR HOME RUN AT 15 TURNS PER METRE. INSTALL 75mm STRIPS OF BACKER ROD EVERY 600mm TO HOLD CONDUCTORS INTO SLOT.

RULE 5 ONLY ONE CONTINUOUS CONDUCTOR SHALL BE INSTALLED IN EACH LOOP AND HOME RUN SLOT TO THE JUNCTION BOX.

RULE 6 LOOP CONDUCTORS MUST BE INSTALLED IMMEDIATELY AFTER THE LOOP AND HOMERUN SLOTS ARE CUT.

STEP 6 INSTALL LOOP SEALANT AFTER CONDUCTORS HAVE BEEN INSTALLED. LOOP SEALANTS SHALL BE HEATED AS PER MANUFACTURER'S INSTRUCTIONS AND NEATLY APPLIED USING A FUNNEL WITH A NARROW SPOUT. ANY EXCESS SEALANT ON ROAD SURFACE SHALL BE REMOVED. AN ADDITIONAL APPLICATION OF LOOP SEALANT MAY BE REQUIRED WHERE THE SEALANT IS NOT UP TO THE PAVEMENT GRADE.

STEP 7 ONCE THE SEALING OF THE SLOT HAS BEEN PROPERLY COMPLETED, A DUST SUCH AS PORTLAND CEMENT SHALL BE SPRINKLED ONTO THE SEALANT TO PREVENT TRACKING BY ROADWAY TRAFFIC. ANY EXCESS DUST SHALL BE SWEEPED OFF THE ROADWAY PRIOR TO ALLOWING TRAFFIC TO PASS OVER THE SEALED SLOT.

RULE 7 SPLICES WILL NOT BE ALLOWED IN LOOP CONDUCTORS OR SHIELDED CABLES.

aaaa

NOTES

- SEE DRAWING SP635-2.8.9 FOR CONTINUATION OF PROCEDURES AND RULES.



No.	Revision	Date	DETECTOR LOOP INSTALLATION PROCEDURES AND RULES	
D				
C				
B	MINISTRY REPRESENTATIVE CHANGED TO MINISTRY ELECTRICAL REPRESENTATIVE	OCT 03	Date	Approved
A	DRAWING NUMBER CHANGED, ROUND LOOPS ADDED	NOV 98	15/11/95	M.C. (Signature on File) Chief Highway Engineer
			SPECIFICATION DRAWING No. SP635-2.8.8	

CONTINUED FROM DRAWING SP635-2.8.8

STEP 8 A LOOP CHECK SHEET AS SHOWN ON DRAWING SP635-2.8.10 SHALL BE COMPLETED EACH TIME A NEW LOOP IS INSTALLED. PAVEMENT CONDITIONS ARE TO BE RECORDED BEFORE ANY SAW CUTS HAVE BEEN MADE. WEATHER CONDITIONS ARE TO BE RECORDED AT THE TIME THAT THE LOOPS ARE SEALED. MEASUREMENTS SHALL BE TAKEN AT THE JUNCTION BOX CLOSEST TO THE LOOP. (SEE RULE 8)

STEP 9 THE SPLICES BETWEEN DETECTOR LOOP CONDUCTORS AND THE SHIELDED CABLE ARE TO BE SOLDERED AND SEALED WITH HEAT SHRINK IN ACCORDANCE WITH DRAWING SP635-2.8.7.

STEP 10 REPEAT STEP 8 AT THE JUNCTION BOX OR VAULT NEAREST CONTROLLER.

RULE 8 LOOP DETECTOR RESISTANCE TO GROUND SHALL BE GREATER THAN 1 MEGAOHM, LOOP RESISTANCE SHALL BE FROM 0 TO 5 OHMS & LOOP INDUCTANCE SHALL BE WITHIN 20% OF THE VALUES SHOWN ON DRAWINGS SP635-2.8.2 TO -2.8.4 OR AS NOTED ON THE PLANS.

STEP 11 SUBMIT THE COMPLETED LOOP CHECK SHEET AND ANY RELEVANT PHOTOGRAPHS TO THE MINISTRY ELECTRICAL REPRESENTATIVE AND THE MINISTRY REGIONAL ELECTRICAL MANAGER. THE TOTAL CIRCUIT INDUCTANCE VALUES AND THE MEGGER TEST VALUES WILL BE USED AS A BASELINE TO VERIFY DEGRADATION IN LOOP PERFORMANCE.

STEP 12 TAG EACH LOOP CABLE AS NOTED ON DRAWINGS SP635-2.5.7 AND -2.5.8.

RULE 9 MAINTAIN THE MAXIMUM SEPARATION POSSIBLE IN THE JUNCTION BETWEEN THE LOOP CONDUCTORS AND POWER CONDUCTORS.

aaaa



No.	Revision	Date	DETECTOR LOOP INSTALLATION PROCEDURES AND RULES	
F				
E				
D				
C	STEP 11 CLARIFIED	OCT 03	Date	Approved
B	DRAWING NUMBER CHANGED	NOV 98	15/11/95	M.C. (Signature on File)
A	RULE 8 REVISED	AUG 96	Chief Highway Engineer	
			SPECIFICATION DRAWING No. SP635-2.8.9	



REFER TO RULE 8 ON DRAWING SP635-2.8.9 FOR MINIMUM ALLOWABLE GROUND TO RESISTANCE AND MAXIMUM VARIATION IN INDUCTANCE VALUES.

Location: _____ Date: _____ Drawing No. _____
 Electrician\Contractor: _____ Company: _____ Ministry Rep.: _____
 Loop Sealant Used: _____ Pavement Conditions*: _____
 Weather Conditions: Air Temp: _____ Precipitation: _____

Loop # as per DWG																				
Phase assignment as per controller																				
Resistance to ground** (ohms)	at loop																			
Loop Resistance (ohms)	at controller																			
Loop Resistance (ohms)	at loop																			
Loop Inductance (micro Henrys)	at controller																			
Loop Inductance (micro Henrys)	at loop																			
Loop Inductance (micro Henrys)	at controller																			

Loop # as per DWG																				
Phase assignment as per controller																				
Resistance to ground** (ohms)	at loop																			
Loop Resistance (ohms)	at controller																			
Loop Resistance (ohms)	at loop																			
Loop Inductance (micro Henrys)	at controller																			
Loop Inductance (micro Henrys)	at loop																			
Loop Inductance (micro Henrys)	at controller																			

* example of possible pavement conditions: good, cracked, sealed cracked, ruts at stop bar, pavement patches
 ** megger test – max 250V DC

No.	Revision	Date
F		
E		
D		
C		
B		
A	DRAWING NUMBERS CHANGED	NOV 98

LOOP CHECK SHEET

Date: 15/11/95 Approved: M.C. (Signature on File)
 Chief Highway Engineer

SPECIFICATION DRAWING No. SP635-2.8.10

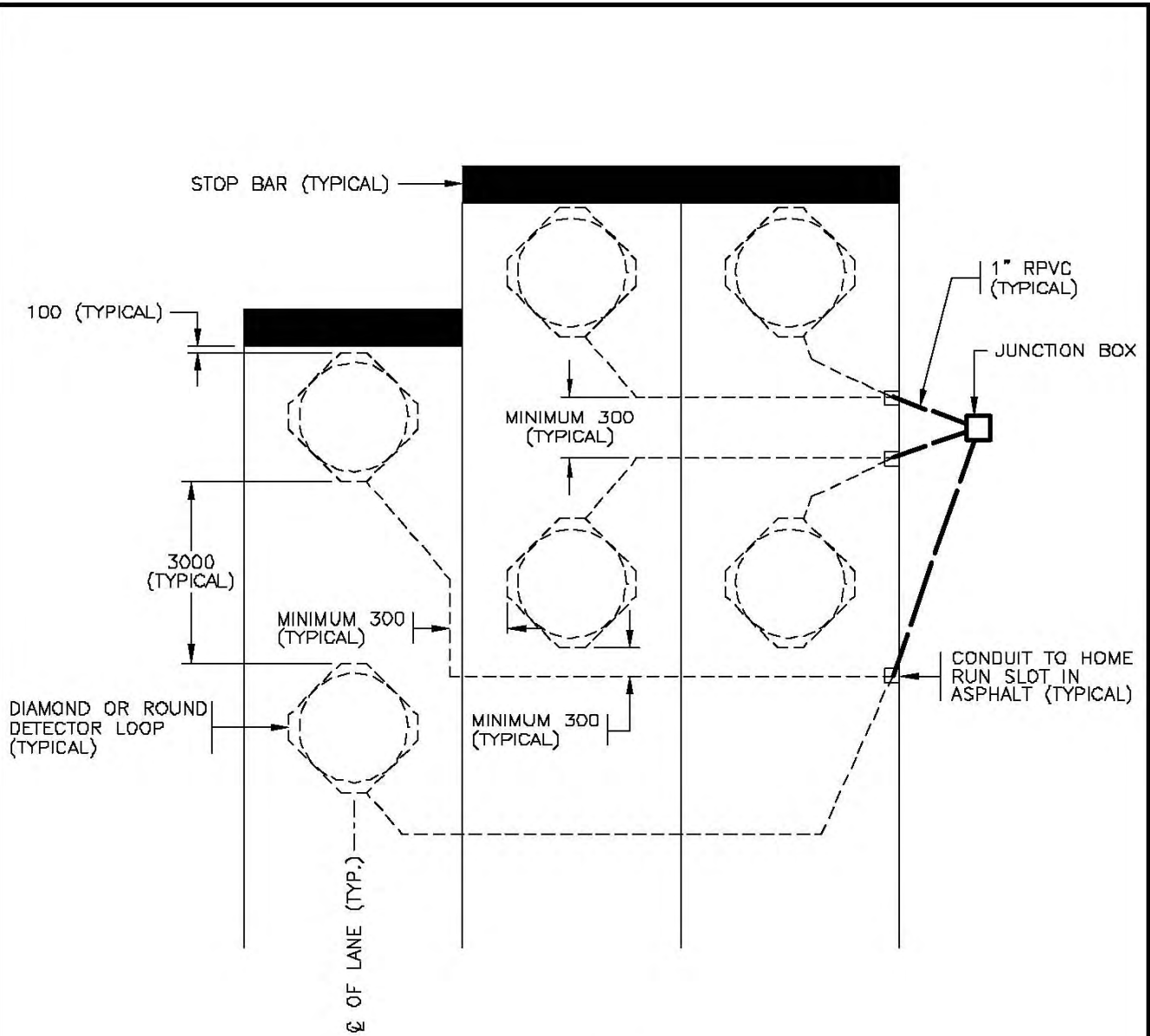

TYPICAL LOOP LAYOUT

NOTES

1. SEE STANDARD SPECIFICATIONS & SPECIAL PROVISIONS FOR ADDITIONAL INFORMATION.
2. ALL DIMENSIONS ARE IN MILLIMETRES UNLESS OTHERWISE NOTED.
3. LOCATE LOOP CONDUITS IN ASPHALT TO SUIT LOOP LOCATIONS & MINIMIZE THE LENGTHS OF HOME RUN SLOTS IN THE ASPHALT.



NOT TO SCALE

No.	Revision	Date	LAYOUT FOR DIAMOND OR ROUND TRAFFIC SIGNAL DETECTOR LOOPS	
E			Date	Approved
D				
C				
B				
A	DRAWING NUMBER CHANGED, ROUND LOOPS ADDED	NOV 98	15/11/95	M.C. (Signature on File) Chief Highway Engineer
			SPECIFICATION DRAWING No. SP635-2.8.11	

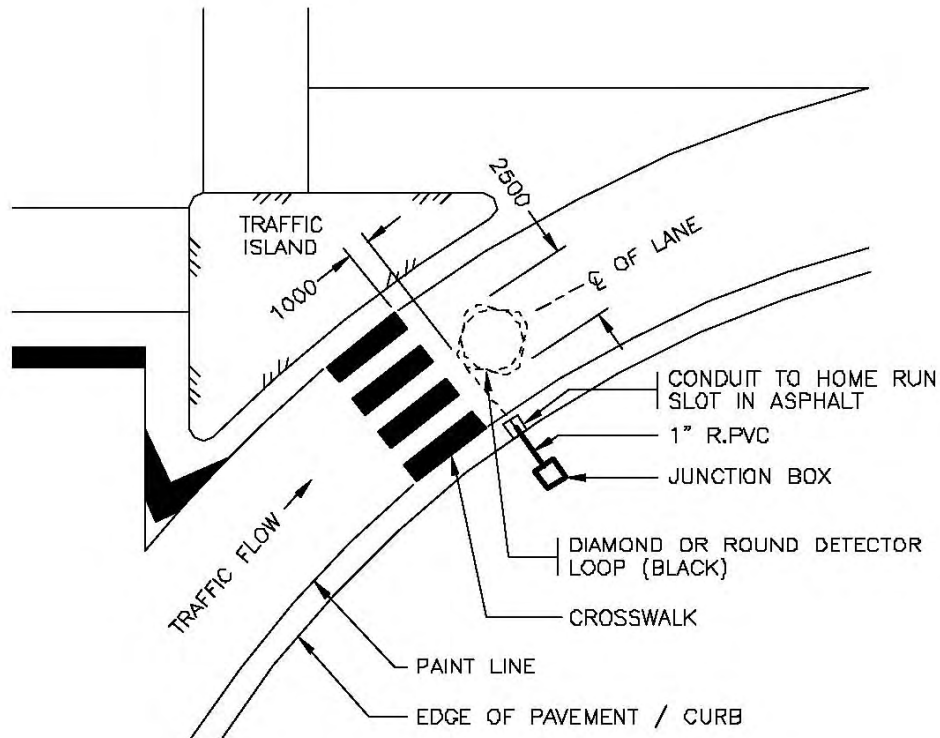

RIGHT TURN LANE WITH TRAFFIC ISLAND SCENARIO SHOWN
PAVEMENT WIDTH UP TO 5900

NOTES

1. SEE STANDARD SPECIFICATIONS & SPECIAL PROVISIONS FOR ADDITIONAL INFORMATION.
2. ALL DIMENSIONS ARE IN MILLIMETRES UNLESS OTHERWISE NOTED.
3. FOR DIAMOND LOOP DETECTOR DETAILS SEE DRAWING SP635-2.8.2 FOR ROUND LOOP DETECTOR DETAILS SEE DRAWING SP635-2.8.3
4. LOCATE LOOP CONDUITS IN ASPHALT TO SUIT LOOP LOCATIONS & MINIMIZE THE LENGTHS OF HOME RUN SLOTS IN THE ASPHALT.



NOT TO SCALE

No.	Revision	Date	LAYOUT FOR DIAMOND OR ROUND COUNTING DETECTOR LOOP	
E			Date	Approved
D				
C				
B				
A	DRAWING NUMBER CHANGED, ROUND LOOPS ADDED	NOV 98	15/11/95 M.C. (Signature on File) Chief Highway Engineer	SPECIFICATION DRAWING No. SP635-2.8.12

LOOP SPACING TABLE			
WIDTH (W)	(A)	(B)	(C)
6000	400	200	400
7000	750	500	750
8000	1100	800	1100
9000	1500	1000	1500

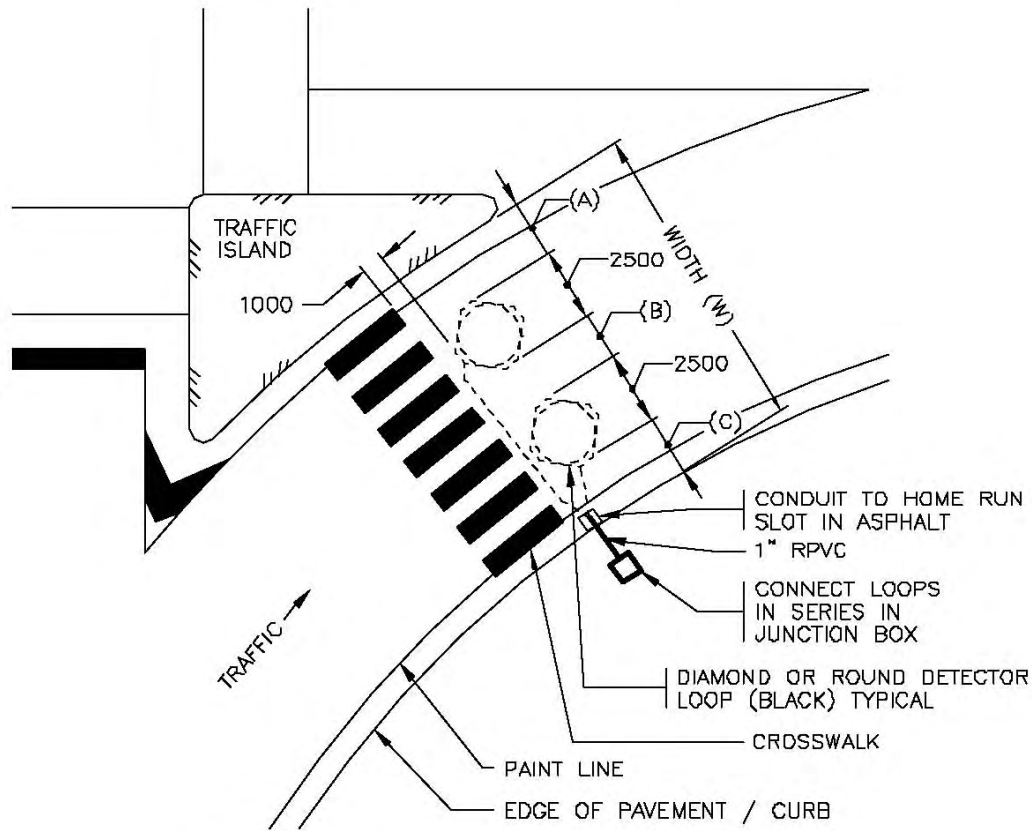

RIGHT TURN LANE WITH TRAFFIC ISLAND SCENARIO SHOWN

PAVEMENT WIDTH BETWEEN 6000 AND 9000

NOTES

1. SEE STANDARD SPECIFICATIONS & SPECIAL PROVISIONS FOR ADDITIONAL INFORMATION.
2. ALL DIMENSIONS ARE IN MILLIMETRES UNLESS OTHERWISE NOTED.
3. FOR DIAMOND DETECTOR LOOP DETAILS SEE DRAWING SP635-2.8.2. FOR ROUND DETECTOR LOOP DETAILS SEE DRAWING SP635-2.8.3.
4. LOCATE LOOP CONDUITS IN ASPHALT TO SUIT LOOP LOCATIONS & MINIMIZE THE LENGTHS OF HOME RUN SLOTS IN THE ASPHALT.

NOT TO SCALE



No.	Revision	Date
E		
D		
C		
B		
A	DRAWING NUMBER CHANGED, ROUND LOOPS ADDED	NOV 98

LAYOUT FOR DIAMOND OR ROUND COUNTING DETECTOR LOOPS

Date Approved
15/11/95 M.C. (Signature on File)
 Chief Highway Engineer

SPECIFICATION DRAWING No.
SP635-2.8.13

ON STRAIGHT SECTIONS OF ROADS, THE LOOP WILL BE CENTERED IN THE LANE.
 ON CURVED ROADS (AS SHOWN BELOW) THE LOOP WILL BE LOCATED, SHAPED AND SIZED TO BEST REFLECT THE TRAVEL PATHS OF VEHICLES.

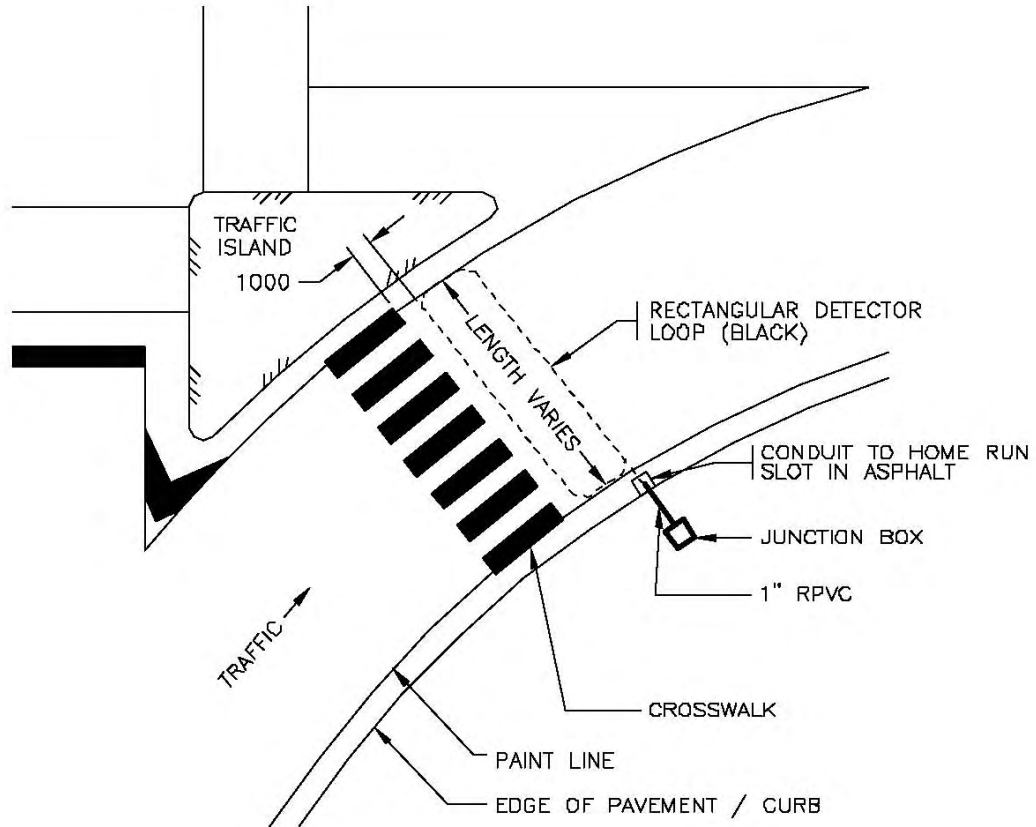

RIGHT TURN LANE WITH TRAFFIC ISLAND SCENARIO SHOWN

NOTES

1. SEE STANDARD SPECIFICATIONS & SPECIAL PROVISIONS FOR ADDITIONAL INFORMATION.
2. ALL DIMENSIONS ARE IN MILLIMETRES UNLESS OTHERWISE NOTED.
3. FOR RECTANGULAR DETECTOR LOOP DETAILS aaaa SEE DRAWING SP635-2.8.4
4. LOCATE LOOP CONDUITS IN ASPHALT TO SUIT LOOP LOCATIONS & MINIMIZE THE LENGTHS OF HOME RUN SLOTS IN THE ASPHALT.



NOT TO SCALE

No.	Revision	Date	LAYOUT FOR RECTANGULAR COUNTING DETECTOR LOOPS	
F			Date	Approved
E			15/11/95	M.C. (Signature on File)
D				Chief Highway Engineer
C			SPECIFICATION DRAWING No. SP635-2.8.14	
B				
A	DRAWING NUMBER CHANGED,	NOV 98		

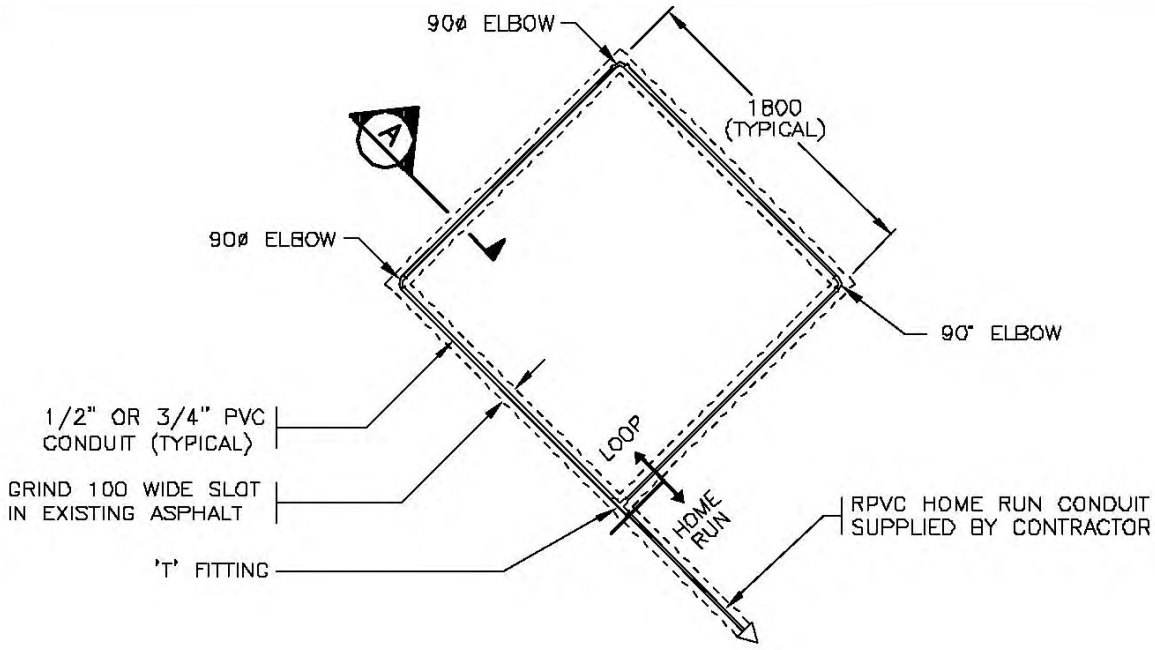

PREFORMED LOOP LAYOUT

4 TURN LOOP SHOWN.
NUMBER OF TURNS MAY VARY
AS NOTED ON THE PLANS OR
AS DIRECTED BY THE MINISTRY
REPRESENTATIVE

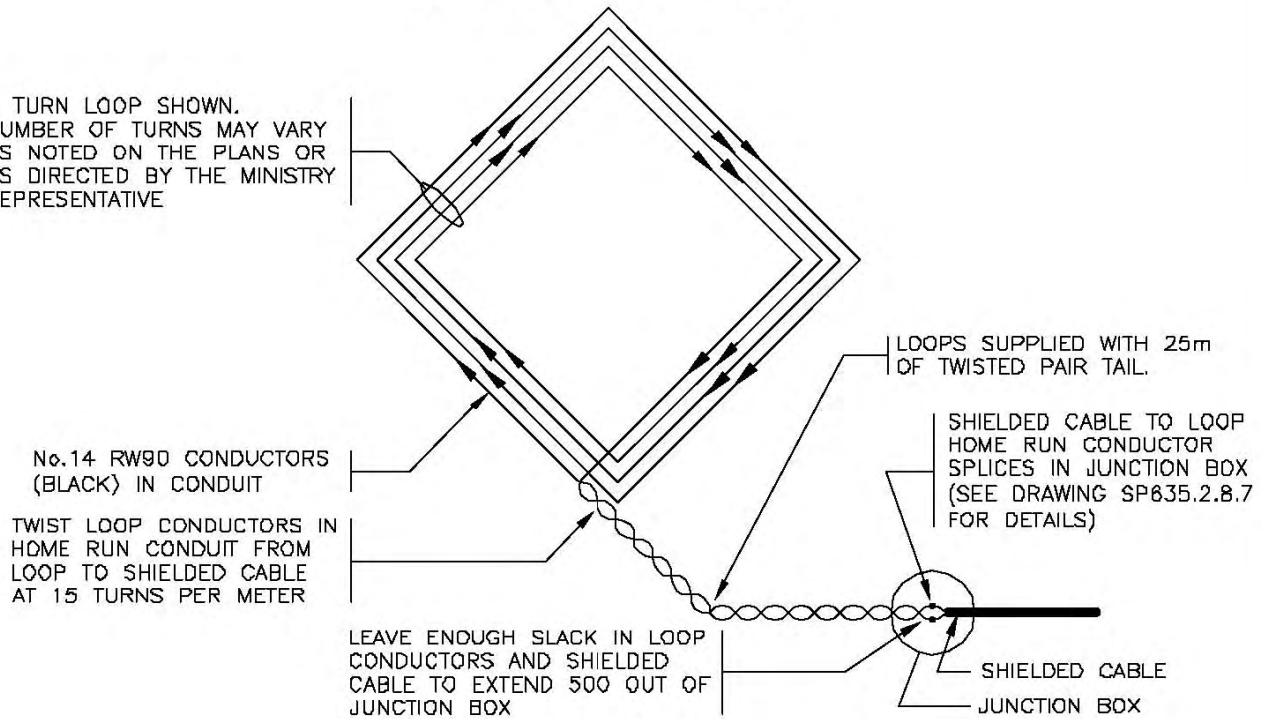

CONDUIT LAYOUT IN PREFORMED LOOP

SEE DRAWING SP635-2.8.16 FOR NOTES
SEE DRAWING SP635-2.8.2 FOR LOOP INDUCTANCE TABLE



NOT TO SCALE

No.	Revision	Date
F		
E		
D		
C		
B		
A		

PRE-FORMED DIAMOND DETECTOR LOOP INSTALLATION DETAILS		
Date	Approved	SPECIFICATION DRAWING No.
16/10/00	M.C. (Signature on File) Chief Engineer	SP635-2.8.15

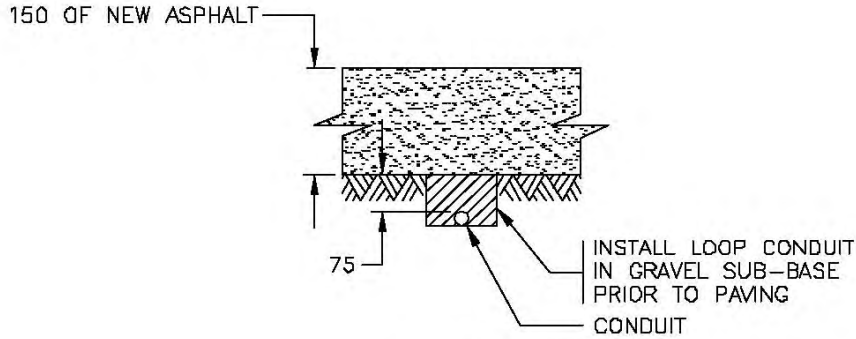

SECTION (A)
NEW ROAD CONSTRUCTION

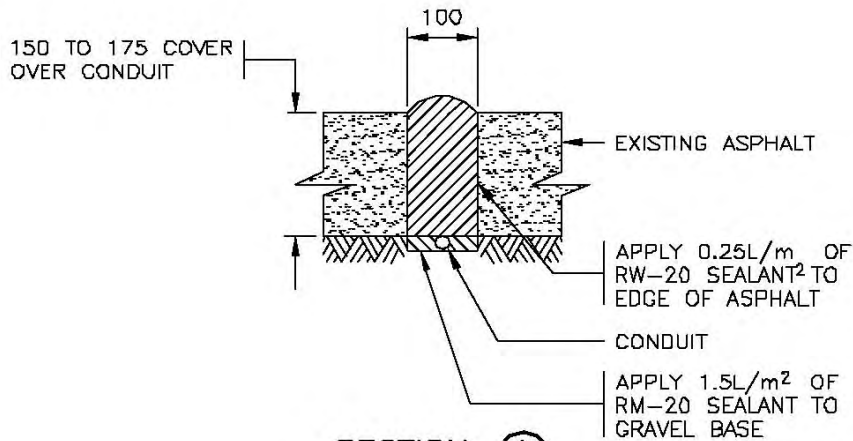

SECTION (A)
EXISTING ROAD SURFACE

NOTES

1. SEE STANDARD SPECIFICATIONS & SPECIAL PROVISIONS FOR ADDITIONAL INFORMATION.
2. ALL DIMENSIONS ARE IN MILLIMETRES UNLESS OTHERWISE NOTED.
3. WHERE INSTALLING PREFORMED LOOPS IN EXISTING ASPHALT GRIND OUT SLOT AND INSTALL PREFORMED LOOP. BACKFILL SLOT WITH HOT MIXED ASPHALT PAVEMENT. COMPACT ASPHALT WITH VIBRATING MECHANICAL COMPACTOR WITH 75mm SQUARE PLATE. WHERE INSTALLING PREFORMED LOOPS IN NEW ROAD CONSTRUCTION, PLACE CONDUIT IN GRAVEL SUB-BASE JUST BELOW ASPHALT. LAYOUT STOP BARS, CURB RETURNS, ISLANDS, MEDIANS, LANE LINES AND LOOPS AND VERIFY WITH MINISTRY REPRESENTATIVE PRIOR TO CONSTRUCTION. FAILURE TO CORRECTLY LOCATE THE LOOPS IN THEIR REQUIRED LOCATIONS WILL RESULT IN REINSTALLATION OF THE LOOPS AT THE CONTRACTORS EXPENSE.
4. PREFORMED LOOPS SHALL MEET THE APPROVAL OF THE MINISTRY REPRESENTATIVE PRIOR TO INSTALLATION.
5. CONTRACTOR SHALL VERIFY LOOPS LOCATIONS (CUT INTO OVERLAYED OR NEW PAVED ROADWAYS) WITH THE MINISTRY REPRESENTATIVE AFTER INSTALLATION.
6. PRE-APPROVED LOOPS ARE NOTED ON THE MINISTRY "PRE-APPROVED PRODUCT LIST". PRE-FORMED LOOPS OR EITHER RIGID OR FLEXIBLE PVC TYPE AND COME COMPLETE WITH 25m HOME RUN OF CONDUCTOR. AS THE HOME RUN LENGTHS WILL VARY, THE CONTRACTOR SHALL SUPPLY PVC CONDUIT FOR HOME RUNS. TYPE OF LOOPS (FLEXIBLE OR RIGID) SHALL BE APPROVED ^{aaaa}BY THE MINISTRY REGIONAL ELECTRICAL MANAGER.

NOT TO SCALE



No.	Revision	Date
F		
E		
D		
C		
B		
A	NOTE 6 REVISED	OCT 03

PRE-FORMED DIAMOND DETECTOR LOOP INSTALLATION DETAILS	
Date	Approved
_____ Chief Highway Engineer	
SPECIFICATION DRAWING No. SP635-2.8.16	

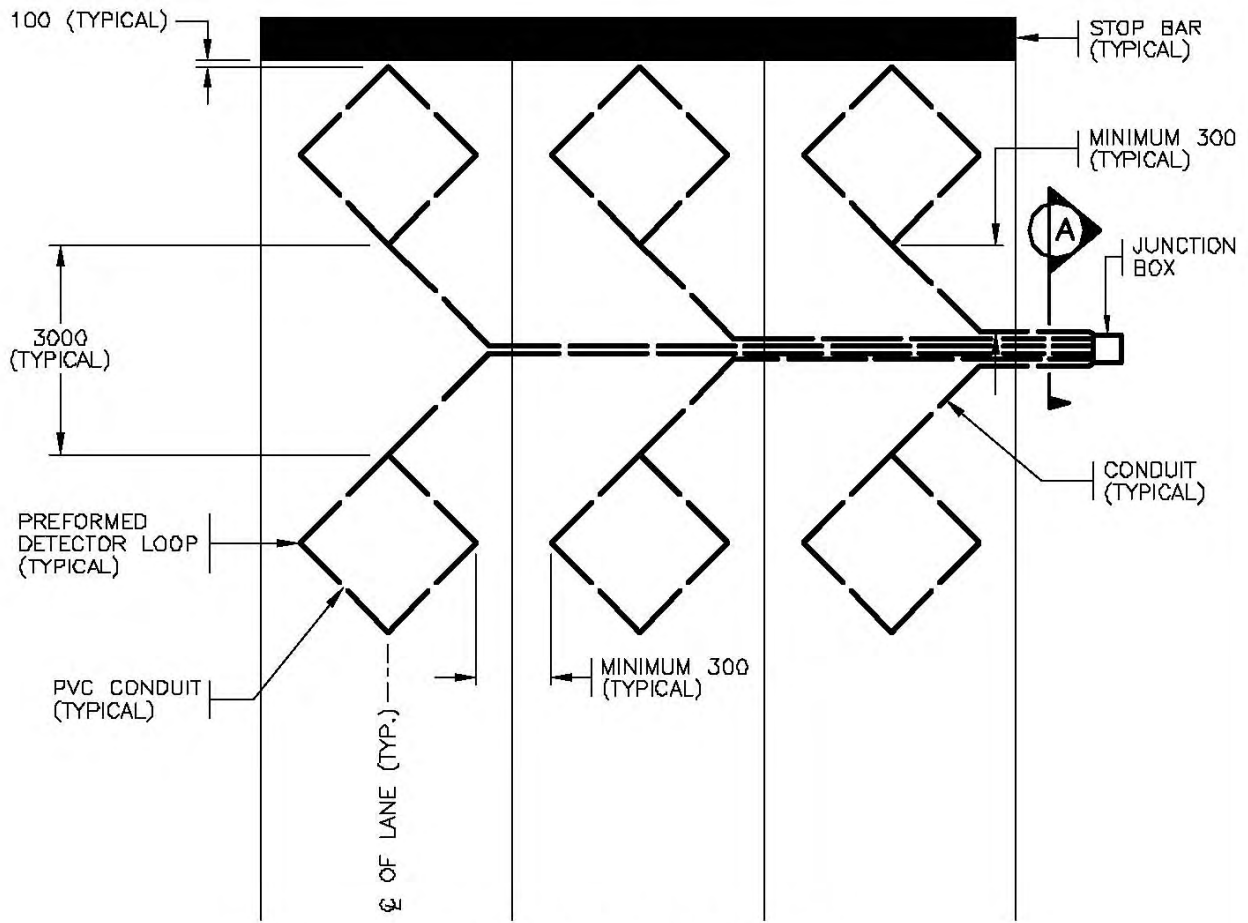

TYPICAL PREFORMED LOOP LAYOUT

INCREASE TRENCH SIZE BY 20mm FOR EVERY ADDITIONAL CONDUIT REQUIRED

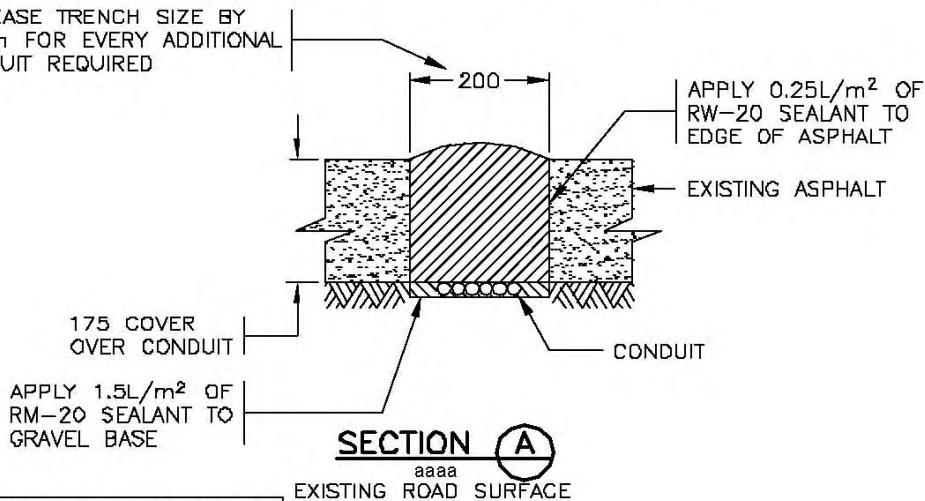

SEE DRAWING SP635-2.8.16 FOR NOTES
 SEE DRAWING SP635-2.8.2 FOR LOOP INDUCTANCE TABLE

NOT TO SCALE



No.	Revision	Date
F		
E		
D		
C		
B		
A		

LAYOUT FOR PRE-FORMED TRAFFIC SIGNAL DETECTOR LOOPS

Date Approved
16/10/00 M.C. [Signature on File]
 Chief Engineer

SPECIFICATION DRAWING No.
SP635-2.8.17

REFER TO THE MINISTRY'S MANUAL OF STANDARD SIGNS FOR SPECIFIC APPLICATIONS WHICH APPLY TO THIS SIGN

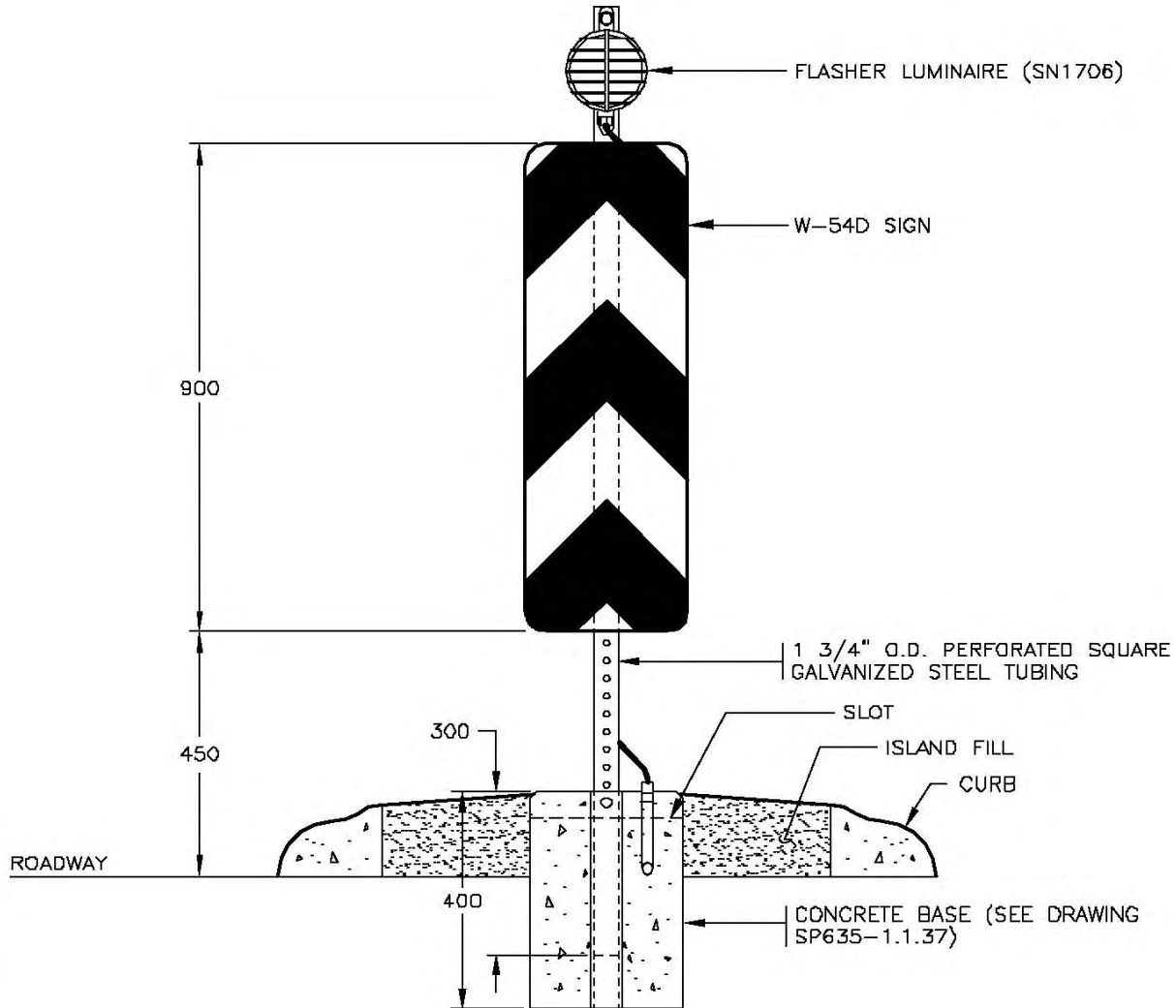

ELEVATION

aaaa

SEE DRAWING SP635-2.9.3 FOR NOTES AND ADDITIONAL DETAILS



NOT TO SCALE

No.	Revision	Date
F		
E		
D		
C	CONCRETE BASE DRAWING REFERENCE REVISED	AUG 96
B	REVISION NOTE 'A' ADDED	AUG 95
A	GENERAL REVISIONS	AUG 94

FLASHER LUMINAIRE INSTALLATION DETAILS ON PERFORATED SQUARE STEEL TUBING (1 SIGN)

Date _____ Approved _____
MAR 94 E.L. (Signature on File)
 Chief Highway Engineer

SPECIFICATION DRAWING No. **SP635-2.9.1**

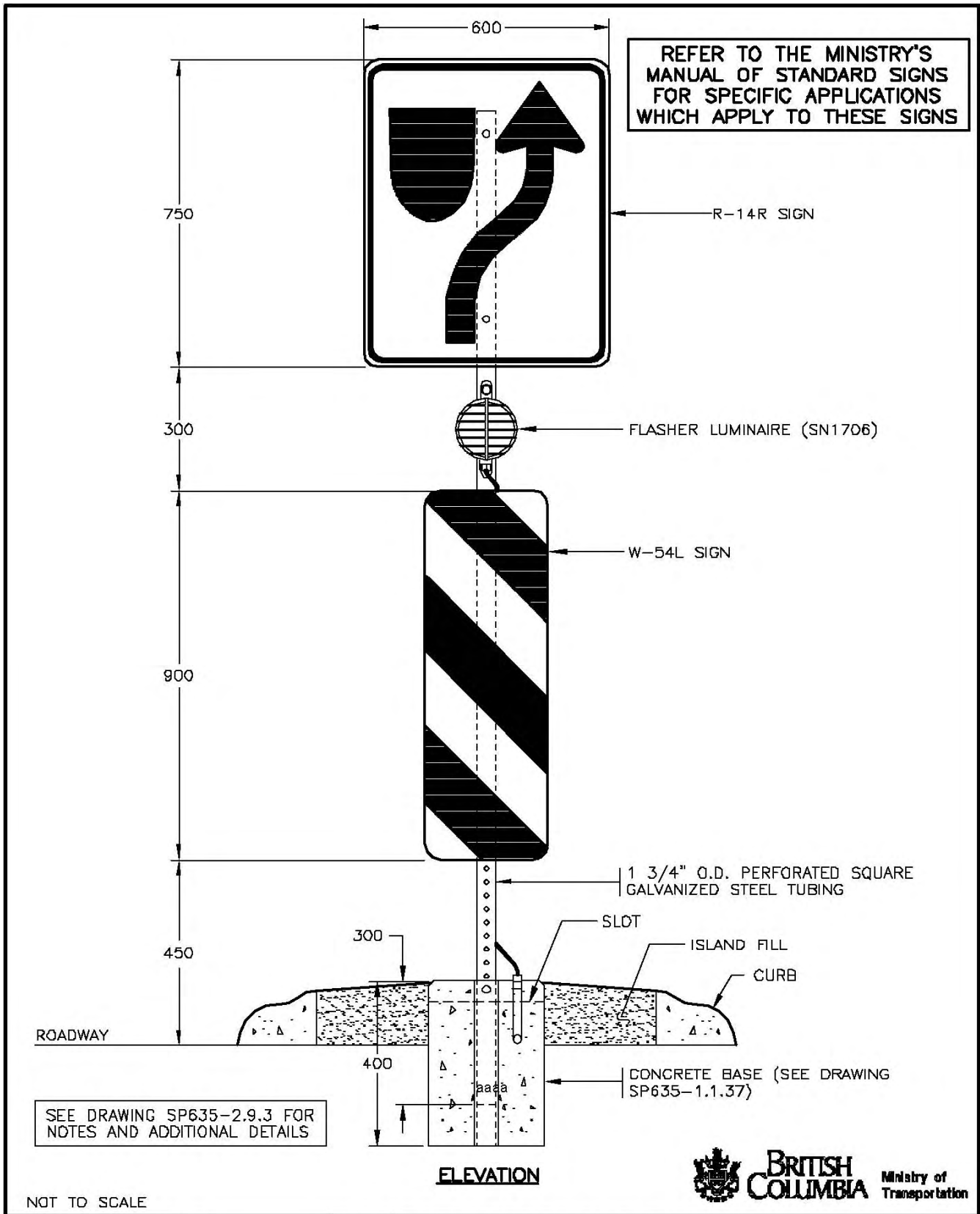

NOT TO SCALE

No.	Revision	Date
F		
E		
D		
C		
B	CONCRETE BASE DRAWING REFERENCE REVISED	AUG 96
A	GENERAL REVISIONS	AUG 94

FLASHER LUMINAIRE INSTALLATION DETAILS ON PERFORATED SQUARE STEEL TUBING (2 SIGNS)		
Date	Approved	SPECIFICATION DRAWING No.
MAR 94	E.L. (Signature on File) Chief Highway Engineer	SP635-2.9.2

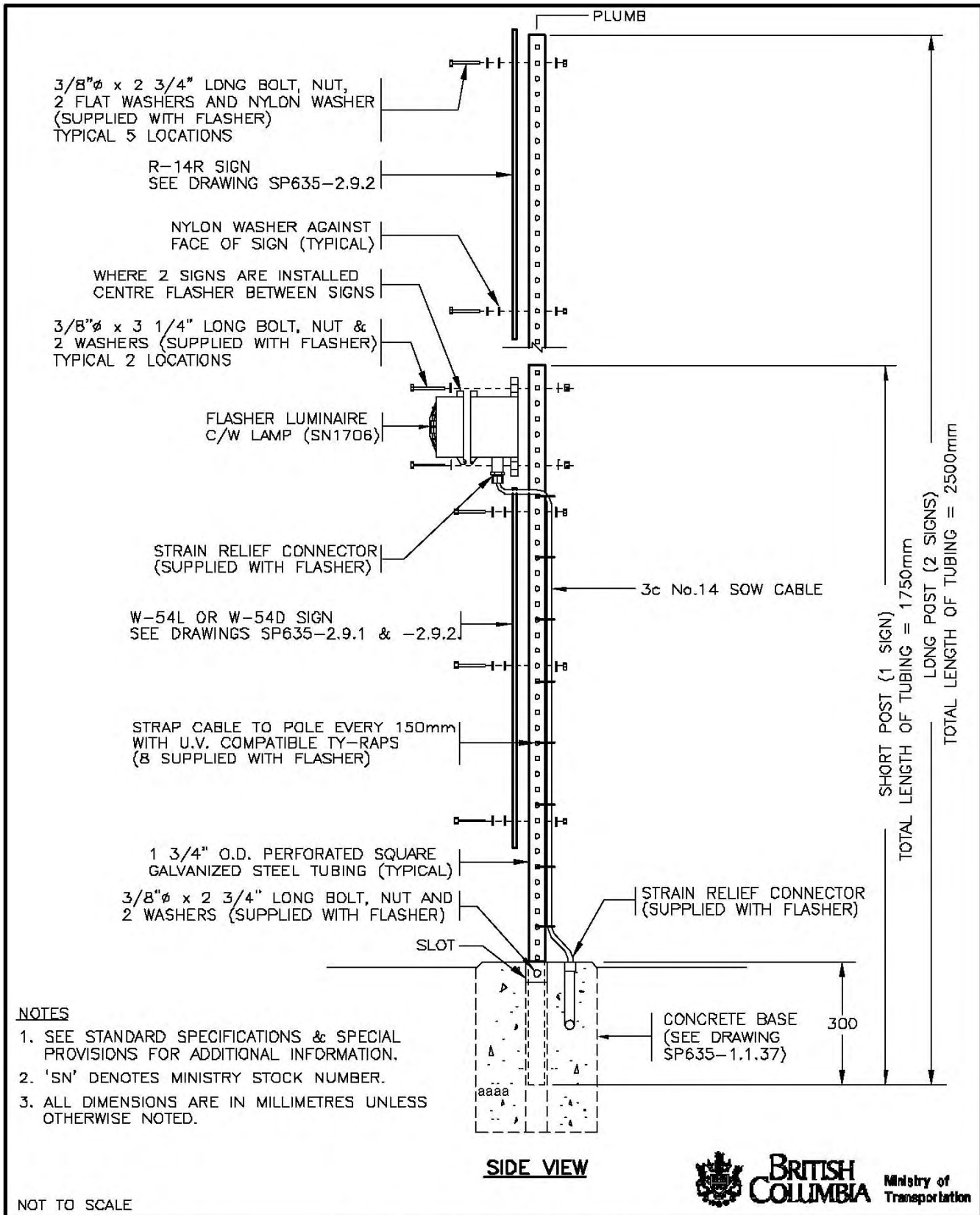

NOTES

1. SEE STANDARD SPECIFICATIONS & SPECIAL PROVISIONS FOR ADDITIONAL INFORMATION.
2. 'SN' DENOTES MINISTRY STOCK NUMBER.
3. ALL DIMENSIONS ARE IN MILLIMETRES UNLESS OTHERWISE NOTED.

NOT TO SCALE



No.	Revision	Date	FLASHER LUMINAIRE INSTALLATION DETAILS ON PERFORATED SQUARE STEEL TUBING	
F			Date	Approved
E			SPECIFICATION DRAWING No. SP635-2.9.3	
D				
C			MAR 94 E.L. (Signature on File) Chief Highway Engineer	
B	3c No.14 CABLE NOT SUPPLIED WITH FLASHER	AUG 96		
A	GENERAL REVISIONS	AUG 94		

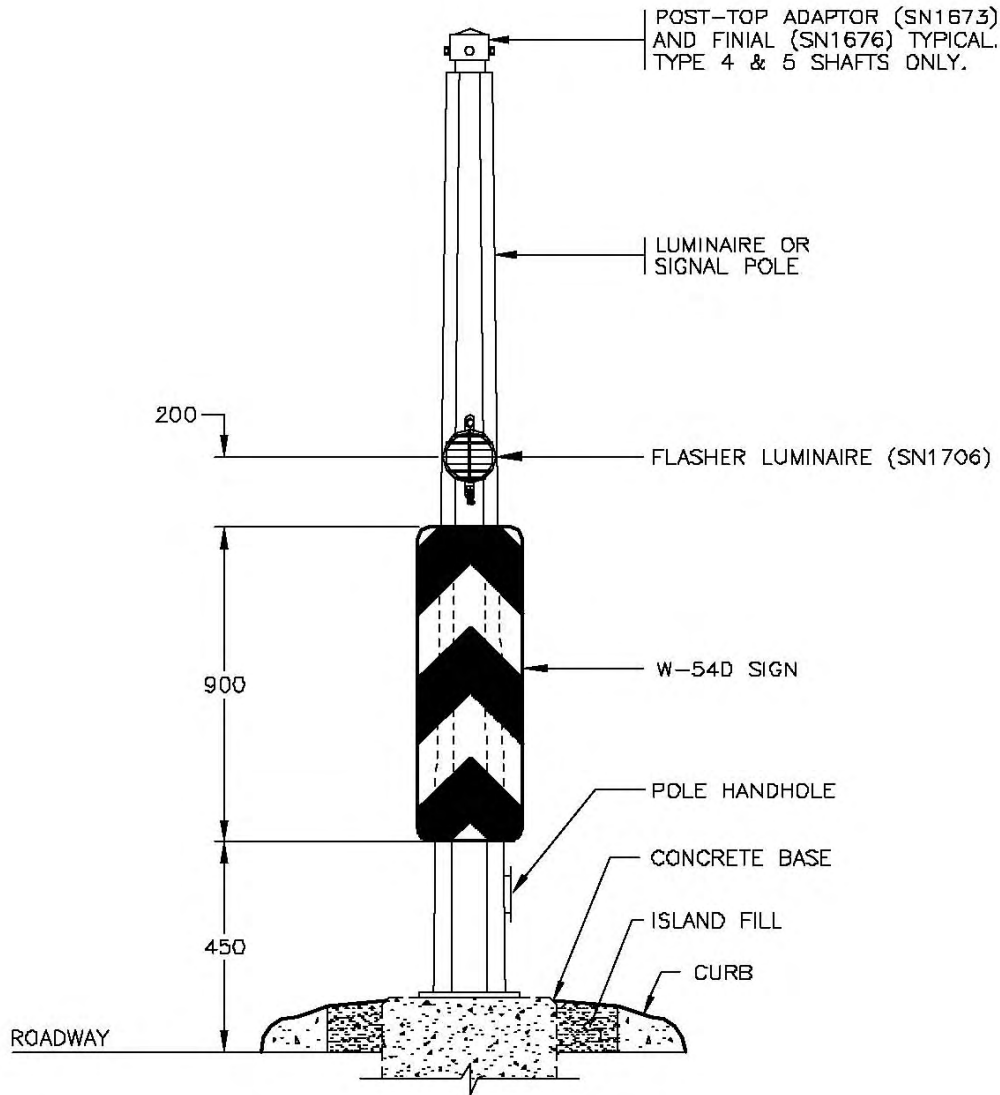

ELEVATION

REFER TO THE MINISTRY'S
MANUAL OF STANDARD SIGNS
FOR SPECIFIC APPLICATIONS
WHICH APPLY TO THESE SIGNS

aaaa

SEE DRAWING SP635-2.9.6 FOR
NOTES AND ADDITIONAL DETAILS



NOT TO SCALE

No.	Revision	Date
F		
E		
D		
C		
B		
A		

**FLASHER LUMINAIRE INSTALLATION DETAILS
ON STEEL POLE (1 SIGN)**

Date: **18/11/94**
Approved: **E.L. (Signature on File)**
Chief Highway Engineer

SPECIFICATION
DRAWING No.
SP635-2.9.4

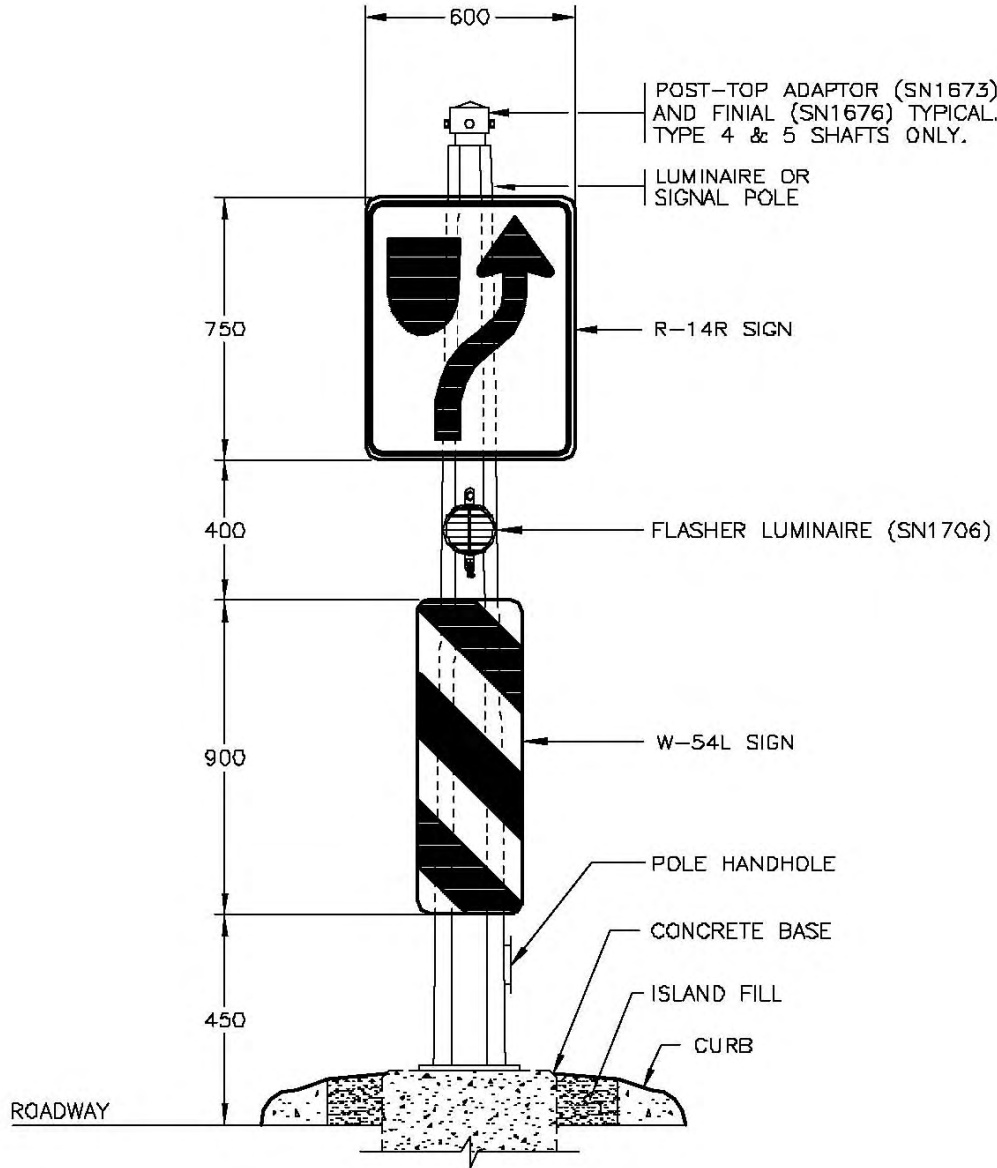

ELEVATION

REFER TO THE MINISTRY'S MANUAL OF STANDARD SIGNS FOR SPECIFIC APPLICATIONS WHICH APPLY TO THESE SIGNS

aaaa

SEE DRAWING SP635-2.9.6 FOR NOTES AND ADDITIONAL DETAILS



NOT TO SCALE

No.	Revision	Date
F		
E		
D		
C		
B		
A		

FLASHER LUMINAIRE INSTALLATION DETAILS ON STEEL POLE (2 SIGNS)

Date: **18/11/94** Approved: **E.L. (Signature on File)**
 Chief Highway Engineer

SPECIFICATION DRAWING No. **SP635-2.9.5**

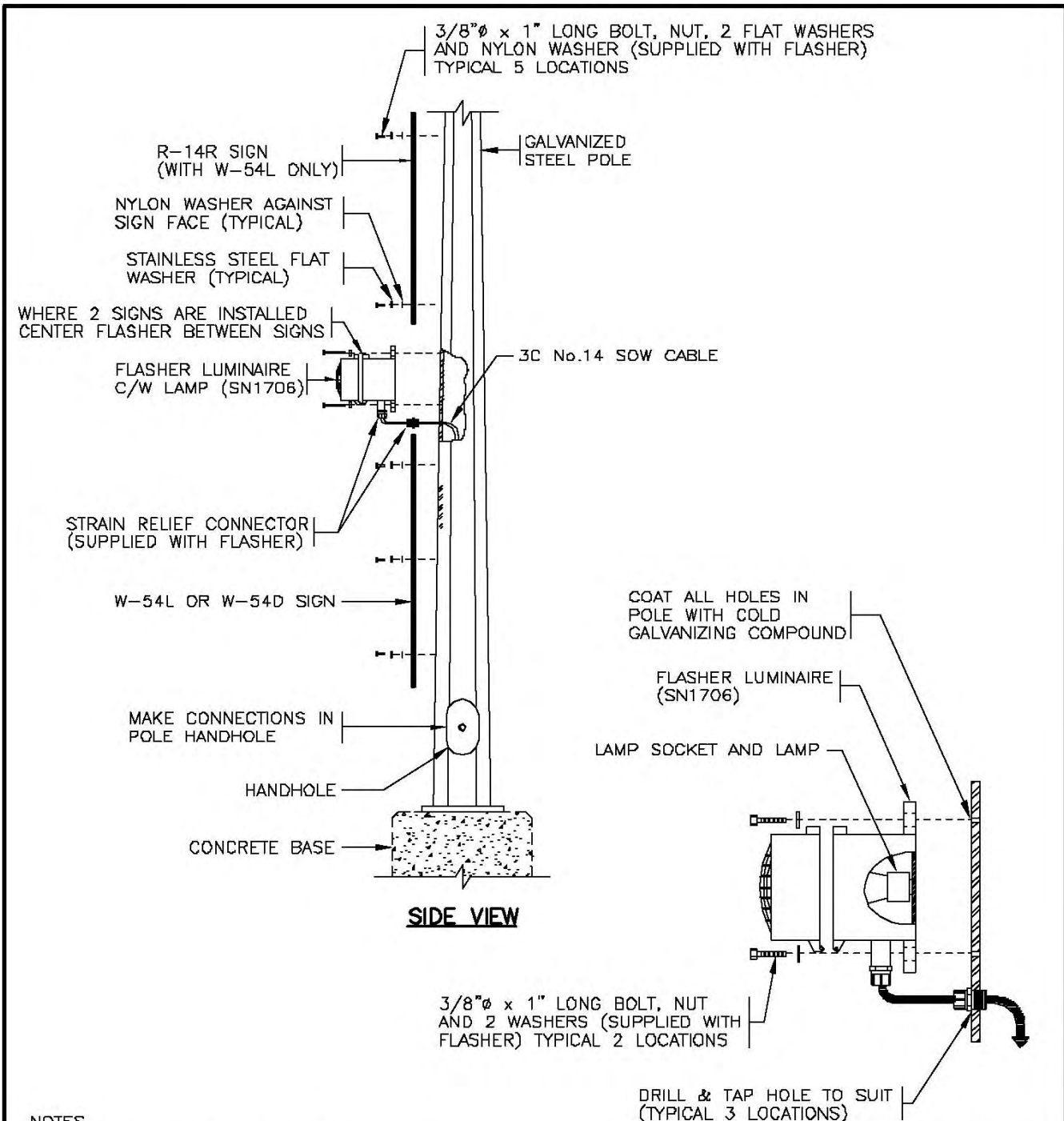

NOTES

1. SEE STANDARD SPECIFICATIONS & SPECIAL PROVISIONS FOR ADDITIONAL INFORMATION.
2. 'SN' DENOTES MINISTRY STOCK NUMBER.
3. ALL DIMENSIONS ARE IN MILLIMETRES UNLESS OTHERWISE NOTED.

aaaa

FLASHER LUMINAIRE MOUNTING DETAIL

N.T.S.



NOT TO SCALE

No.	Revision	Date
F		
E		
D		
C		
B		
A	3C No.14 NDT SUPPLIED WITH FLASHER	AUG 96

FLASHER LUMINAIRE INSTALLATION DETAILS ON STEEL POLE

Date **18/11/94** Approved **M.C. (Signature on File)**
 Chief Highway Engineer

SPECIFICATION DRAWING No. **SP635-2.9.6**

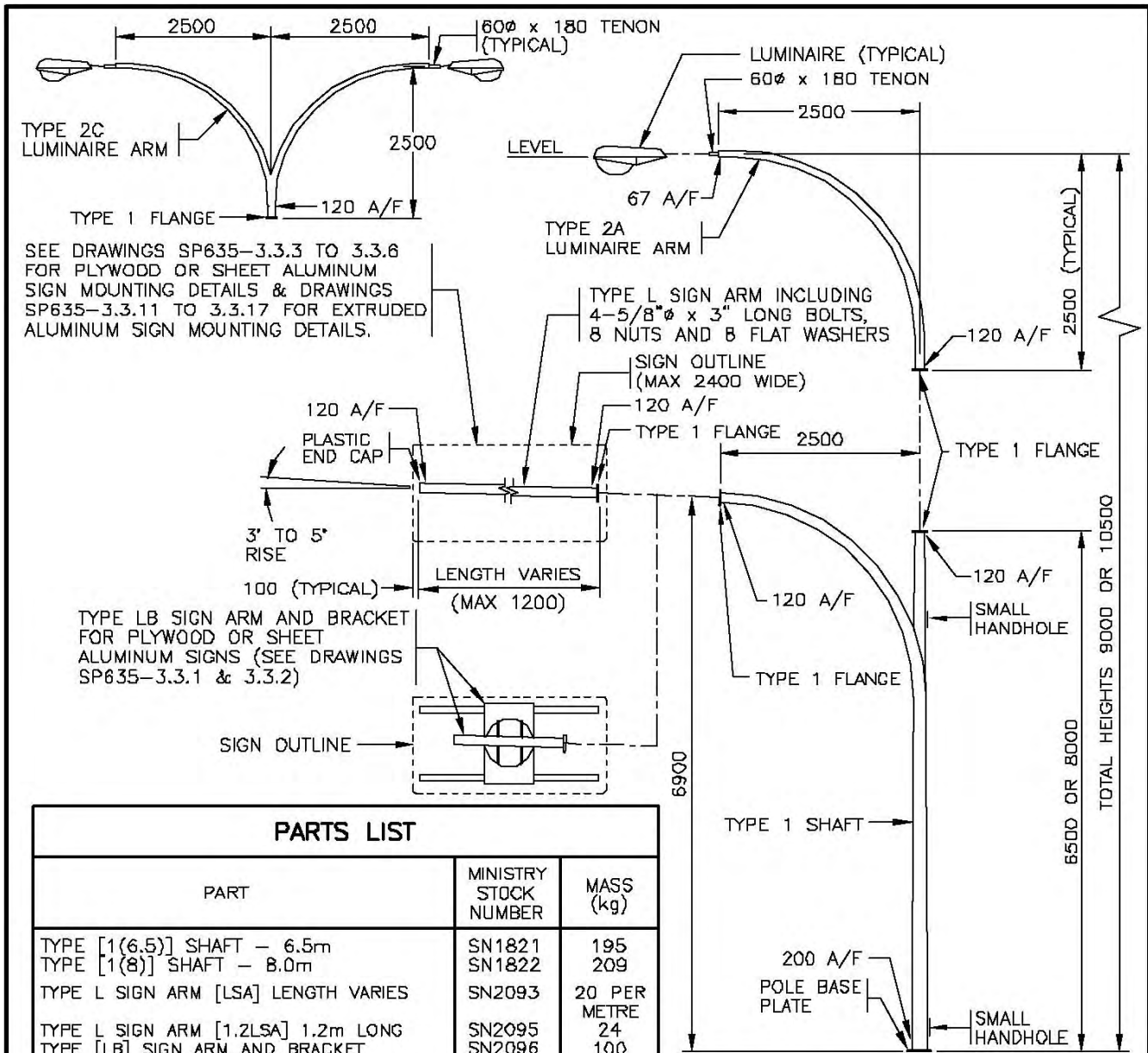

PARTS LIST		
PART	MINISTRY STOCK NUMBER	MASS (kg)
TYPE [1(6.5)] SHAFT - 6.5m	SN1821	195
TYPE [1(8)] SHAFT - 8.0m	SN1822	209
TYPE L SIGN ARM [LSA] LENGTH VARIES	SN2093	20 PER METRE
TYPE L SIGN ARM [1.2LSA] 1.2m LONG	SN2095	24
TYPE [LB] SIGN ARM AND BRACKET	SN2096	100
TYPE [2A] LUMINAIRE ARM	SN1832	35
TYPE [2C] LUMINAIRE ARM	SN1833	65
POST TOP TENON [PTT]	SN1831	5
TYPE 1 FLANGE COVER PLATE [1FCP]	SN1367	1.5

* [] I.D. LABEL ON POLE

NOTES

- FOR ADDITIONAL INFORMATION.
- 2. SEE DRAWING SP635-3.1.2 FOR TYPE 1 SHAFT, BOLT KITS AND POLE ASSEMBLY DETAILS.
- 3. ALL DIMENSIONS ARE IN MILLIMETRES UNLESS OTHERWISE NOTED.

aaaa

ELEVATION

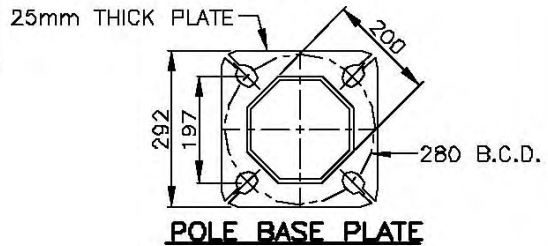

NOT TO SCALE

No.	Revision	Date
F		
E		
D		
C		
B	SHEET ALUMINUM SIGN ADDED	APR 05
A	COUPLING DELETED ON SIGN ARM	NOV 01

TYPE 1 SHAFT INSTALLATION DETAILS (SIGN POLE)

Date Approved
24/02/97 M.C. (Signature on File)
 Chief Highway Engineer

SPECIFICATION DRAWING No.
SP635-3.1.1

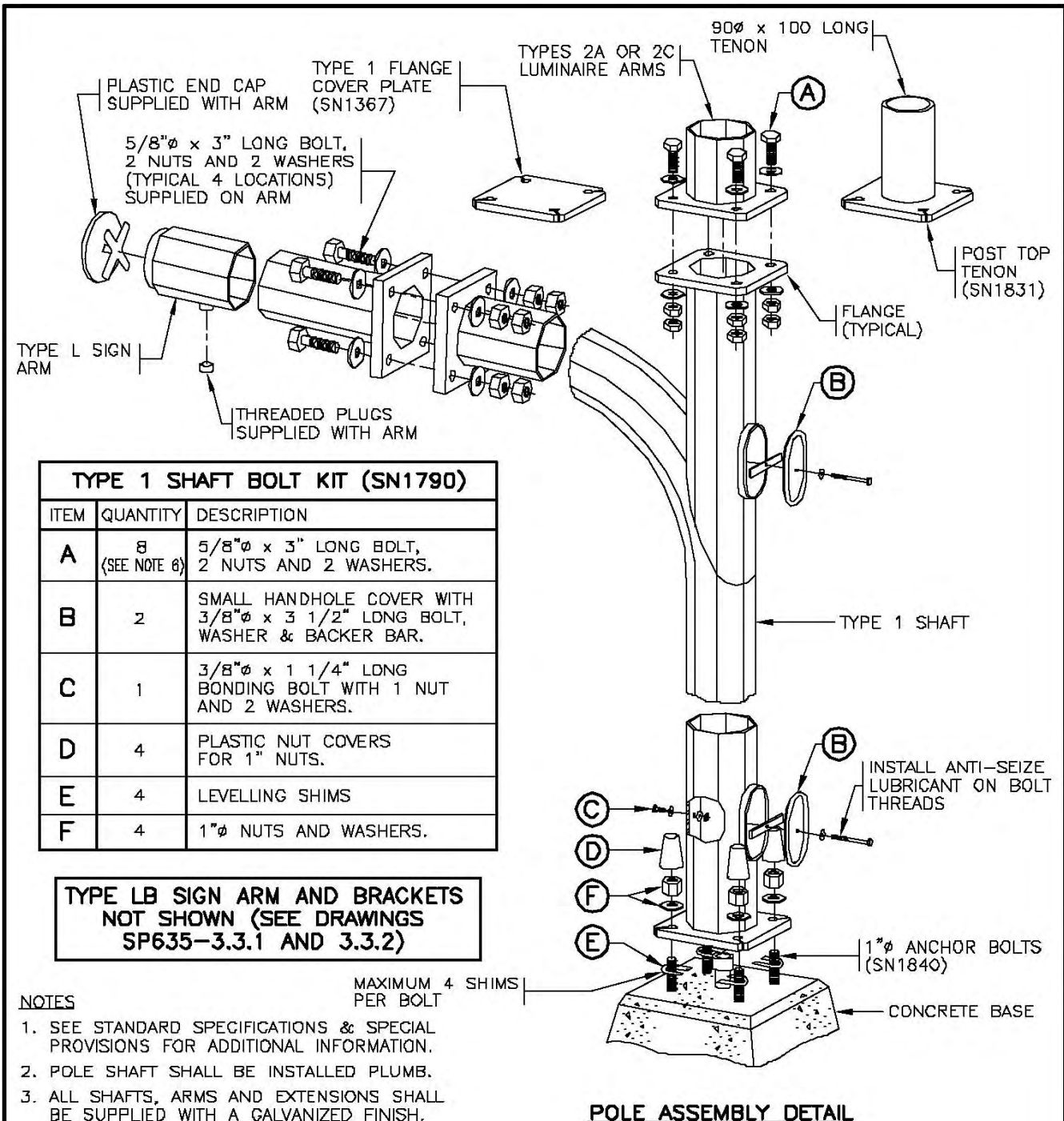

TYPE 1 SHAFT BOLT KIT (SN1790)

ITEM	QUANTITY	DESCRIPTION
A	8 (SEE NOTE 6)	5/8"Ø x 3" LONG BOLT, 2 NUTS AND 2 WASHERS.
B	2	SMALL HANDHOLE COVER WITH 3/8"Ø x 3 1/2" LONG BOLT, WASHER & BACKER BAR.
C	1	3/8"Ø x 1 1/4" LONG BONDING BOLT WITH 1 NUT AND 2 WASHERS.
D	4	PLASTIC NUT COVERS FOR 1" NUTS.
E	4	LEVELLING SHIMS
F	4	1"Ø NUTS AND WASHERS.

TYPE LB SIGN ARM AND BRACKETS NOT SHOWN (SEE DRAWINGS SP635-3.3.1 AND 3.3.2)

NOTES

1. SEE STANDARD SPECIFICATIONS & SPECIAL PROVISIONS FOR ADDITIONAL INFORMATION.
2. POLE SHAFT SHALL BE INSTALLED PLUMB.
3. ALL SHAFTS, ARMS AND EXTENSIONS SHALL BE SUPPLIED WITH A GALVANIZED FINISH.
4. APPLY GREASE TO ANCHOR BOLT THREADS.
5. TOUCH UP ANY SCRATCHES IN GALVANIZED SURFACES WITH COLD GALVANIZING COMPOUND.
6. 4 EXTRA BOLTS, AS BOLTS ARE SUPPLIED WITH SIGN ARM.
7. ALL DIMENSIONS ARE IN MILLIMETERS UNLESS OTHERWISE NOTED.

NOT TO SCALE

aaaa



No.	Revision	Date	TYPE 1 SHAFT INSTALLATION DETAILS (SIGN POLE)	
E			Date	Approved
D				
C				
B				
A	ANTI-SEIZING LUBRICANT NOTED ON HANDHOLE BOLT	NOV 98	24/02/97 M.C. (Signature on File) Chief Highway Engineer	SPECIFICATION DRAWING No. SP635-3.1.2

SEE DRAWINGS SP635-3.3.3 TO 3.3.6 FOR PLYWOOD OR SHEET ALUMINUM SIGN MOUNTING DETAILS & DRAWINGS SP635-3.3.11 TO 3.3.17 FOR EXTRUDED ALUMINUM SIGN MOUNTING DETAILS.

TYPE L SIGN ARM INCLUDING 4-5/8"φ x 3" LONG BOLTS, 8 NUTS AND 8 FLAT WASHERS

SIGN OUTLINE (MAX 2400 WIDE)

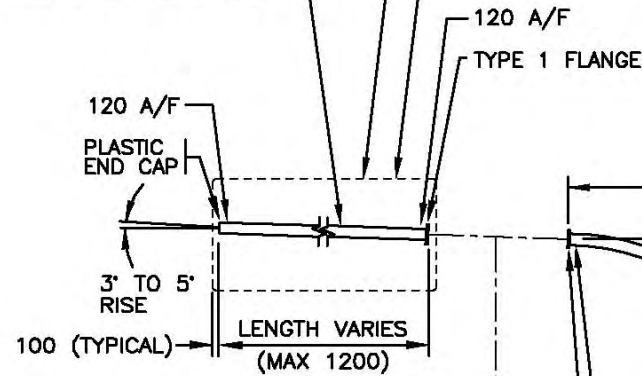

TYPE LB SIGN ARM AND BRACKET FOR PLYWOOD OR SHEET ALUMINUM SIGNS (SEE DRAWINGS SP635-3.3.1 AND 3.3.2)

SIGN OUTLINE

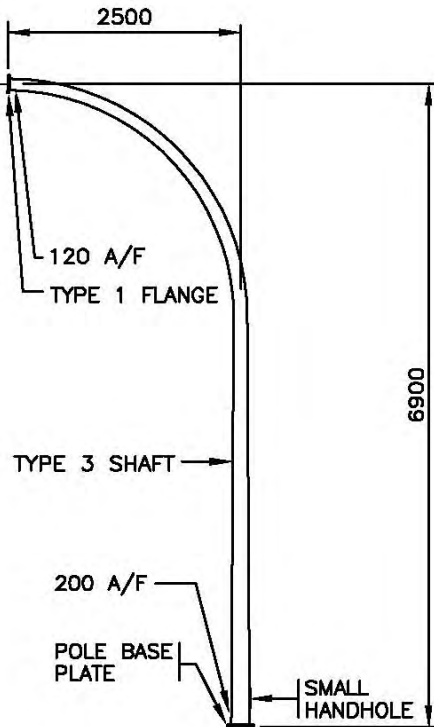

ELEVATION

PARTS LIST		
PART	MINISTRY STOCK NUMBER	MASS (kg)
TYPE [3] SHAFT	SN1826	186
TYPE L SIGN ARM [LSA] LENGTH VARIES	SN2093	20 PER METRE
TYPE L SIGN ARM [1.2LSA] 1.2m LONG	SN2095	24
TYPE [LB] SIGN ARM AND BRACKET	SN2096	100

* [] I.D. LABEL ON POLE

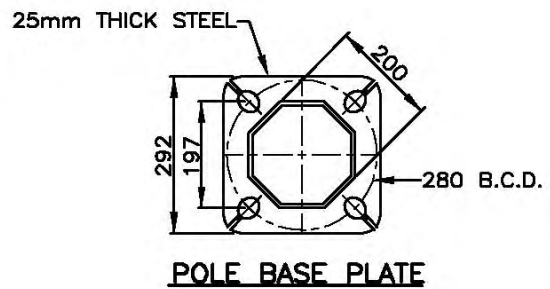

POLE BASE PLATE

NOTES

- SEE STANDARD SPECIFICATIONS & SPECIAL PROVISIONS FOR ADDITIONAL INFORMATION.
- SEE DRAWING SP635-3.1.4 FOR TYPE 3 SHAFT, BOLT KITS AND POLE ASSEMBLY DETAILS. aaaa
- ALL DIMENSIONS ARE IN MILLIMETRES UNLESS OTHERWISE NOTED.

NOT TO SCALE



No.	Revision	Date	TYPE 3 SHAFT INSTALLATION DETAILS (SIGN POLE)		SPECIFICATION DRAWING No. SP635-3.1.3
F			Date	Approved	
E			24/02/97	M.C. (Signature on File)	
D				Chief Highway Engineer	
C					
B	SHEET ALUMINUM SIGN ADDED	APR 05			
A	COUPLING DELETED ON SIGN ARM	NOV 01			

**TYPE LB SIGN ARM AND BRACKETS
NOT SHOWN (SEE DRAWINGS
SP635-3.3.1 AND 3.3.2)**

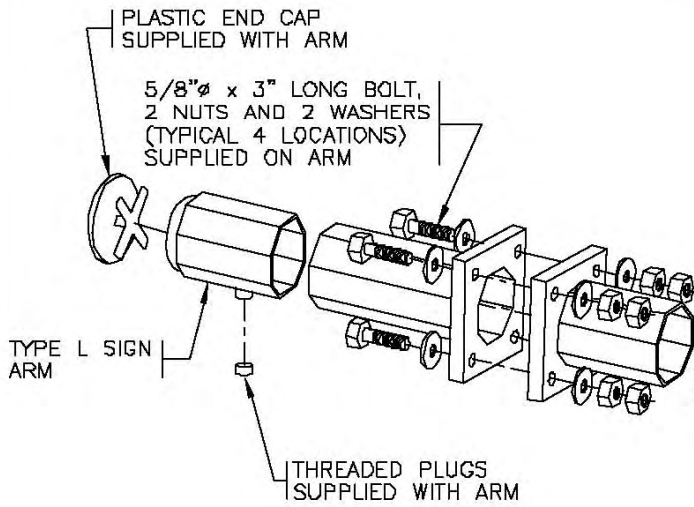

TYPE 3 SHAFT BOLT KIT (SN1791)

ITEM	QUANTITY	DESCRIPTION
A	8 (SEE NOTE 6)	5/8"φ x 3" LONG BOLT, 2 NUTS AND 2 WASHERS.
B	1	SMALL HANDHOLE COVER WITH 3/8"φ x 3 1/2" LONG BOLT, WASHER & BACKER BAR.
C	1	3/8"φ x 1 1/4" LONG BONDING BOLT WITH 1 NUT AND 2 WASHERS.
D	4	PLASTIC NUT COVERS FOR 1" NUTS.
E	4	LEVELLING SHIMS.
F	4	1"φ NUTS AND WASHERS.

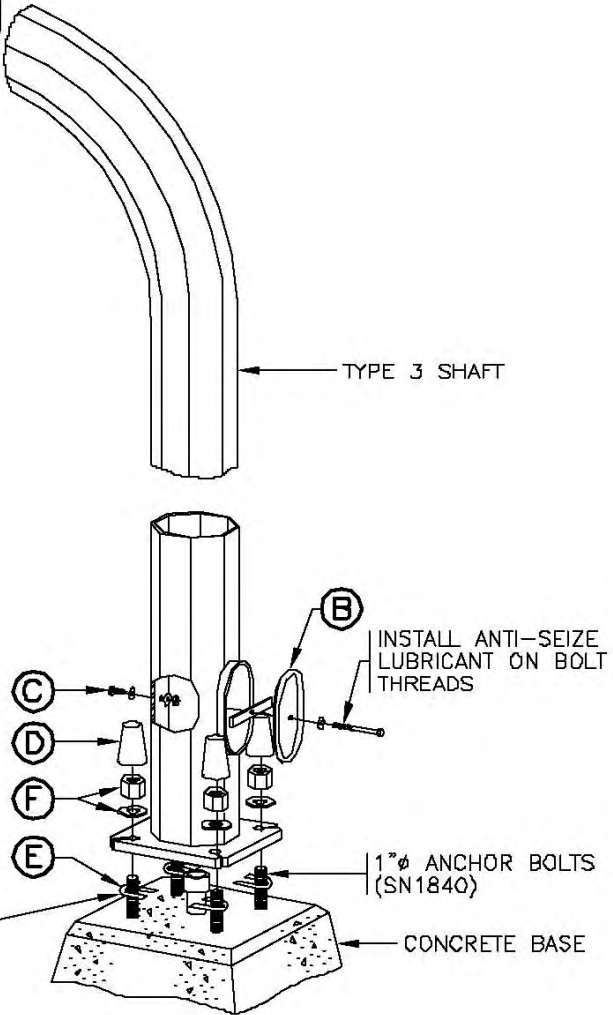

NOTES

1. SEE STANDARD SPECIFICATIONS & SPECIAL PROVISIONS FOR ADDITIONAL INFORMATION.
2. POLE SHAFT SHALL BE INSTALLED PLUMB.
3. ALL SHAFTS, ARMS AND EXTENSIONS SHALL BE SUPPLIED WITH A GALVANIZED FINISH.
4. APPLY GREASE TO ANCHOR BOLT THREADS.
5. TOUCH UP ANY SCRATCHES IN GALVANIZED SURFACES WITH COLD GALVANIZING COMPOUND.
6. 4 EXTRA BOLTS, AS BOLTS ARE SUPPLIED WITH SIGN ARM.

NOT TO SCALE

aaaa



No.	Revision	Date
E		
D		
C		
B		
A	ANTI-SEIZING LUBRICANT NOTED ON HANDHOLE BOLT	NOV 98

**TYPE 3 SHAFT INSTALLATION DETAILS
(SIGN POLE)**

Date	Approved	SPECIFICATION DRAWING No.
24/02/97	M.C. (Signature on File) Chief Highway Engineer	SP635-3.1.4

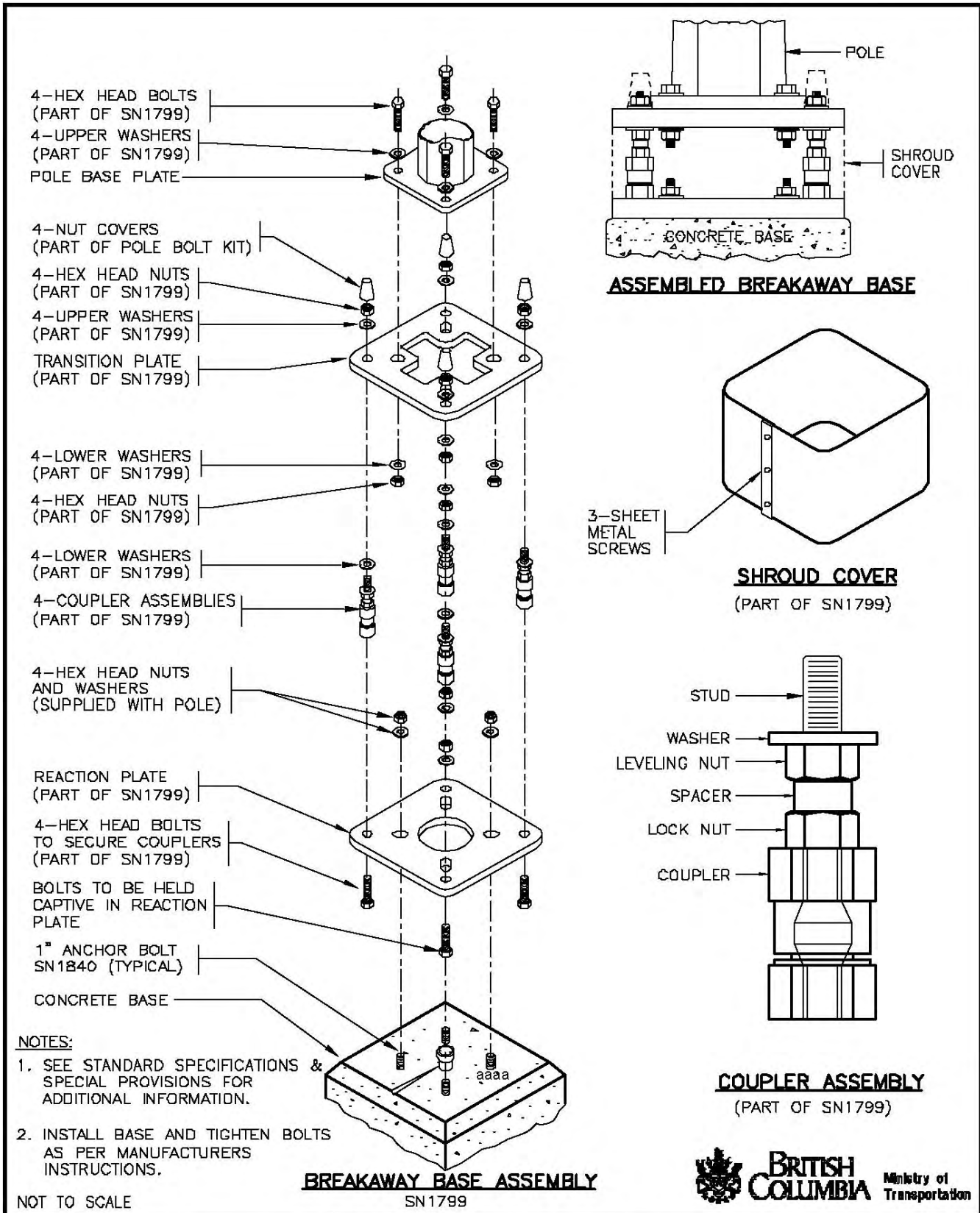

No.	Revision	Date	BREAKAWAY BASE FOR ADVANCED WARNING AND DIRECTIONAL SIGNS ON TYPE 1 AND 3 POLES		SPECIFICATION DRAWING No. SP635-3.1.5
F			Date	Approved	
E			24/02/97	M.C. (Signature on File)	
D				Chief Highway Engineer	
C					
B					
A					

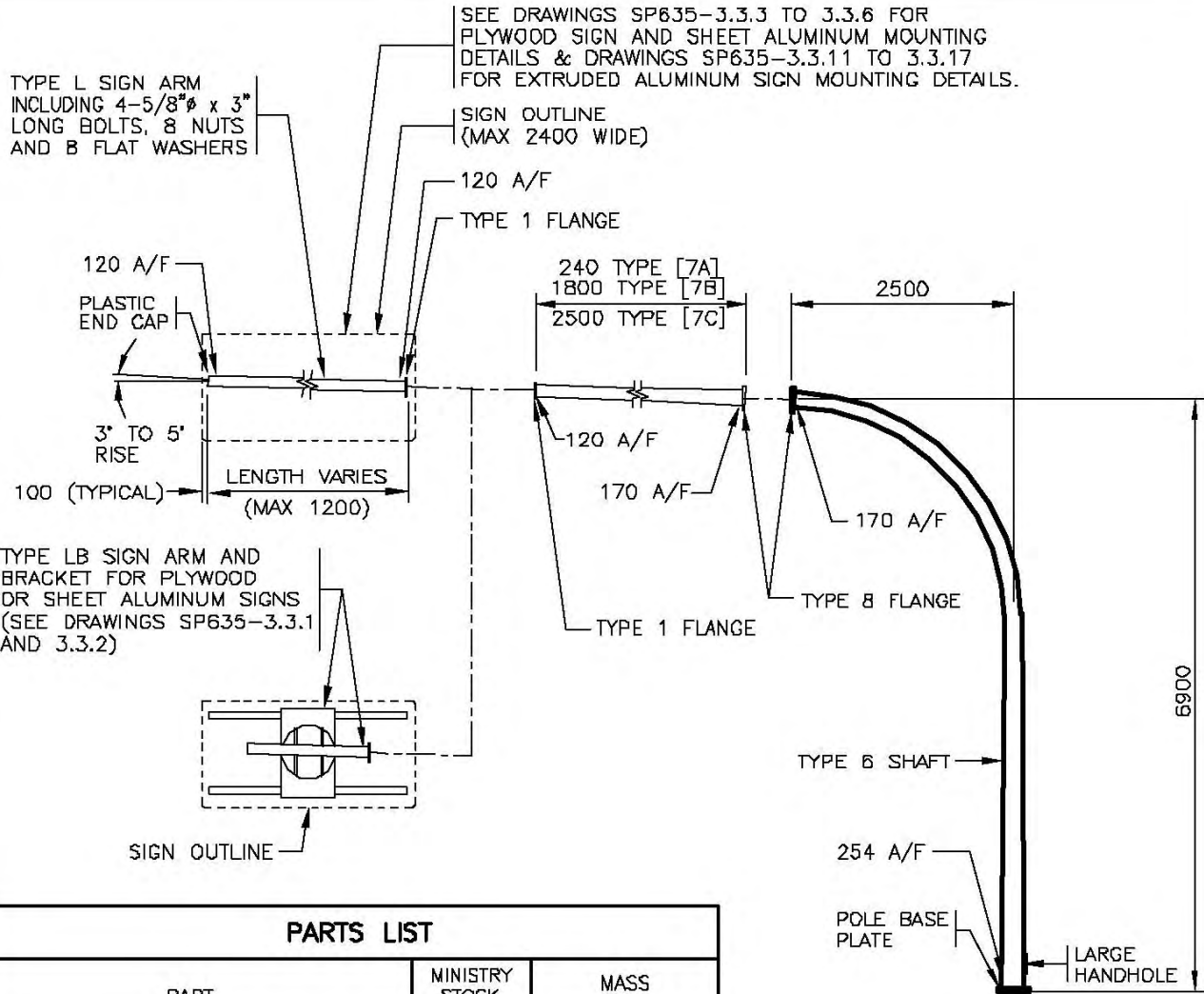

TYPE LB SIGN ARM AND BRACKET FOR PLYWOOD OR SHEET ALUMINUM SIGNS (SEE DRAWINGS SP635-3.3.1 AND 3.3.2)

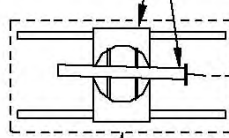

PARTS LIST

PART	MINISTRY STOCK NUMBER	MASS (kg)
TYPE [6] SHAFT	SN1829	412
TYPE L SIGN ARM [LSA] LENGTH VARIES	SN2093	20 PER METRE
TYPE L SIGN ARM [1.2LSA] 1.2m LONG	SN2095	24
TYPE [LB] SIGN ARM AND BRACKET	SN2096	100
TYPE [7A] EXTENSION - 0.24m	SN1890A	20
TYPE [7B] EXTENSION - 1.8m	SN1890B	69
TYPE [7C] EXTENSION - 2.5m	SN1890C	86
TYPE 1 FLANGE COVER PLATE [1FCP]	SN1367	1.5
TYPE 8 FLANGE COVER PLATE [8FCP]	SN2089	2.5

* [] I.D. LABEL ON POLE

NOTES

- SEE STANDARD SPECIFICATIONS & SPECIAL PROVISIONS FOR ADDITIONAL INFORMATION.
- SEE DRAWING SP635-3.1.7 FOR TYPE 6 SHAFT, BOLT KITS AND POLE ASSEMBLY DETAILS.
- ALL DIMENSIONS ARE IN MILLIMETRES UNLESS OTHERWISE NOTED.

NOT TO SCALE

ELEVATION

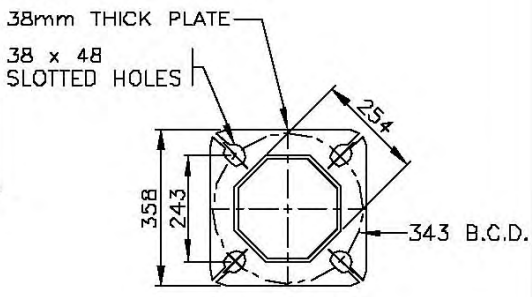

POLE BASE PLATE



No.	Revision	Date
F		
E	SHEET ALUMINUM SIGN ADDED	APR 01
D	COUPLING DELETED ON SIGN ARM	NOV 05
C	L SIGN ARM & DRAWING No. REVISED	AUG 96
B	L SIGN ARM MAX LENGTH & PLATE HOLE SIZE ADDED	AUG 95
A	GENERAL REVISION	AUG 94

TYPE 6 SHAFT INSTALLATION DETAILS (SIGN POLE)

Date: **30/09/93** Approved: **E.L. (Signature on File)**
 Chief Highway Engineer

SPECIFICATION DRAWING No. **SP635-3.1.6**

**TYPE LB SIGN ARM AND BRACKETS
NOT SHOWN (SEE DRAWINGS
SP635-3.3.1 AND 3.3.2)**

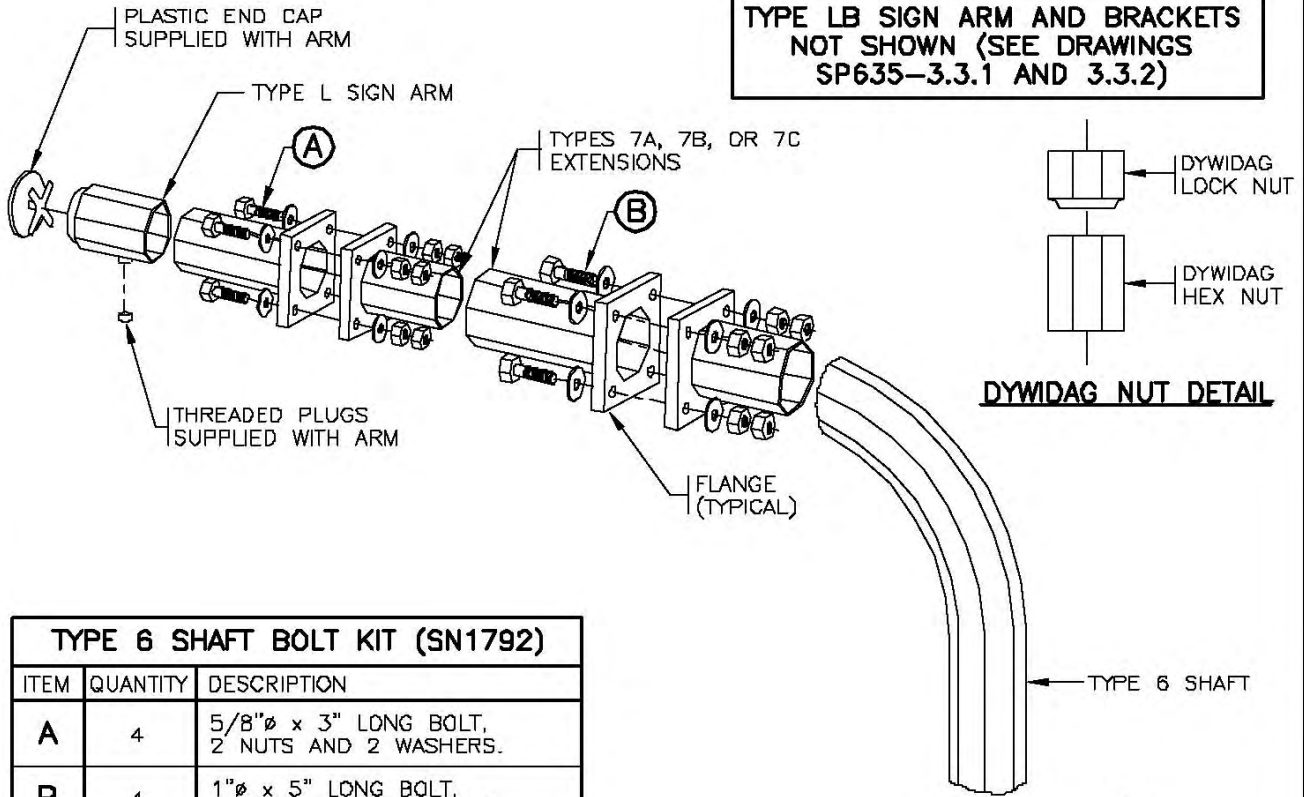

TYPE 6 SHAFT BOLT KIT (SN1792)		
ITEM	QUANTITY	DESCRIPTION
A	4	5/8"φ x 3" LONG BOLT, 2 NUTS AND 2 WASHERS.
B	4	1"φ x 5" LONG BOLT, 2 NUTS AND 2 WASHERS.
C	1	LARGE HANDHOLE COVER WITH 2-3/8"φ x 1" LONG BOLTS AND 2 WASHERS.
D	1	3/8"φ x 1 1/4" LONG BONDING BOLT WITH 1 NUT AND 2 WASHERS.
E	4	LEVELLING SHIMS.

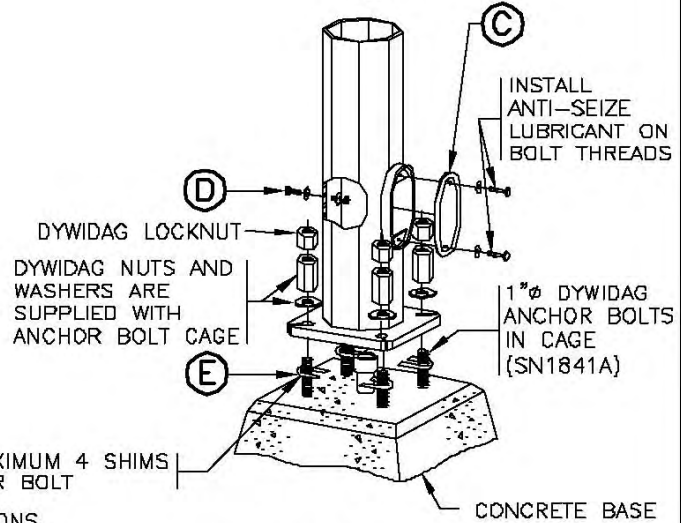

POLE ASSEMBLY DETAIL

NOTES

1. SEE STANDARD SPECIFICATIONS & SPECIAL PROVISIONS FOR ADDITIONAL INFORMATION.
2. POLE SHAFT SHALL BE INSTALLED PLUMB.
3. ALL SHAFTS, ARMS AND EXTENSIONS SHALL BE SUPPLIED WITH A GALVANIZED FINISH.
4. APPLY GREASE TO ANCHOR BOLT THREADS. TO ANCHOR BOLT THREADS.
5. TOUCH UP ANY SCRATCHES IN GALVANIZED SURFACES WITH COLD GALVANIZING COMPOUND.

NOT TO SCALE



No.	Revision	Date
E		
D	ANTI-SEIZE LUBRICANT NOTED ON HANDHOLE BOLT	NOV 98
C	DRAWING NUMBER REVISED	AUG 96
B	END CAP SUPPLIED ON L SIGN ARM	AUG 95
A	GENERAL REVISION	AUG 94

TYPE 6 SHAFT INSTALLATION DETAILS (SIGN POLE)		
Date	Approved	SPECIFICATION DRAWING No.
30/09/93	E.L. (Signature on File) Chief Highway Engineer	SP635-3.1.7

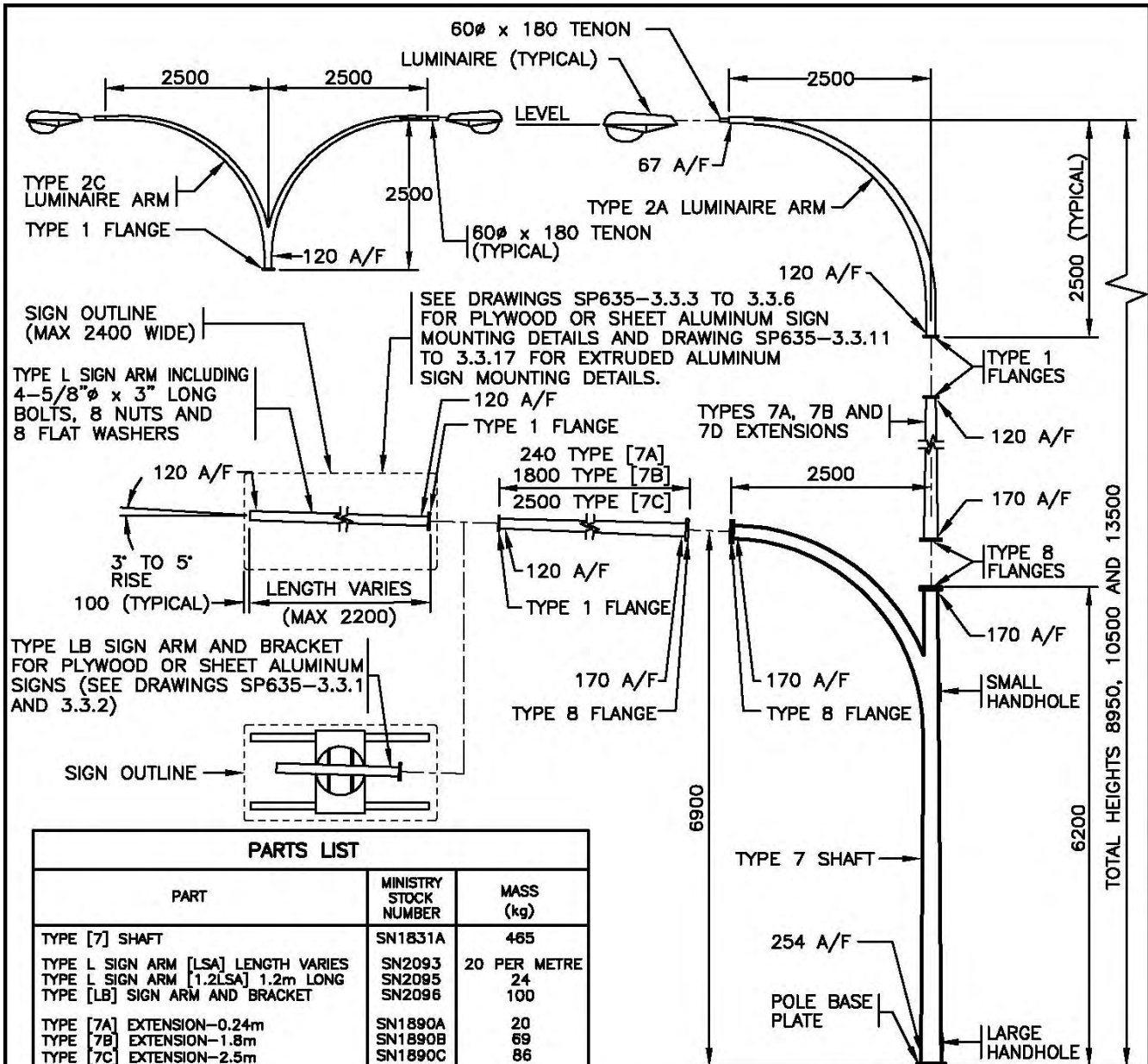

PARTS LIST		
PART	MINISTRY STOCK NUMBER	MASS (kg)
TYPE [7] SHAFT	SN1831A	465
TYPE L SIGN ARM [LSA] LENGTH VARIES	SN2093	20 PER METRE
TYPE L SIGN ARM [1.2LSA] 1.2m LONG	SN2095	24
TYPE [LB] SIGN ARM AND BRACKET	SN2096	100
TYPE [7A] EXTENSION-0.24m	SN1890A	20
TYPE [7B] EXTENSION-1.8m	SN1890B	69
TYPE [7C] EXTENSION-2.5m	SN1890C	86
TYPE [7D] EXTENSION-4.8m	SN1890D	154
TYPE [2A] LUMINAIRE ARM	SN1832	35
TYPE [2C] LUMINAIRE ARM	SN1833	65
POST TOP TENON [PTT]	SN1831	5
TYPE 1 FLANGE COVER PLATE [1FCP]	SN1367	1.5
TYPE 8 FLANGE COVER PLATE [8FCP]	SN2089	2.5

* [] I.D. LABEL ON POLE

NOTES

- SEE STANDARD SPECIFICATIONS & SPECIAL PROVISIONS FOR ADDITIONAL INFORMATION. aaaa
- SEE DRAWING SP635-3.1.9 FOR TYPE 7 SHAFT, BOLT KITS AND POLE ASSEMBLY DETAILS.
- ALL DIMENSIONS ARE IN MILLIMETRES UNLESS OTHERWISE NOTED.

NOT TO SCALE

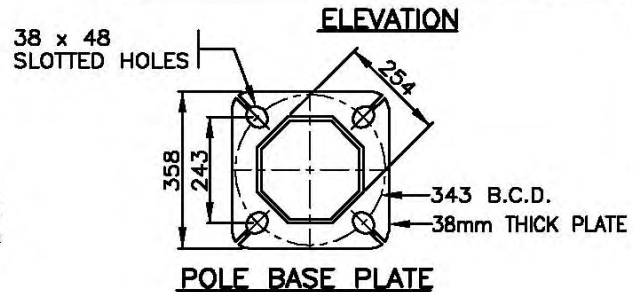

No.	Revision	Date
F		
E	SHEET ALUMINUM SIGN ADDED	APR 05
D	COUPLING DELETED ON SIGN ARM	NOV 01
C	L SIGN ARM & DRAWING No. REVISED	AUG 96
B	L SIGN ARM MAX LENGTH & 7C EXT. ADDED	AUG 95
A	GENERAL REVISION	AUG 94

TYPE 7 SHAFT INSTALLATION DETAILS (SIGN POLE)		
Date	Approved	SPECIFICATION DRAWING No.
30/09/93	E.L. (Signature on File) Chief Highway Engineer	SP635-3.1.8

TYPE LB SIGN ARM AND BRACKETS NOT SHOWN (SEE DRAWINGS SP635-3.3.1 AND 3.3.2)

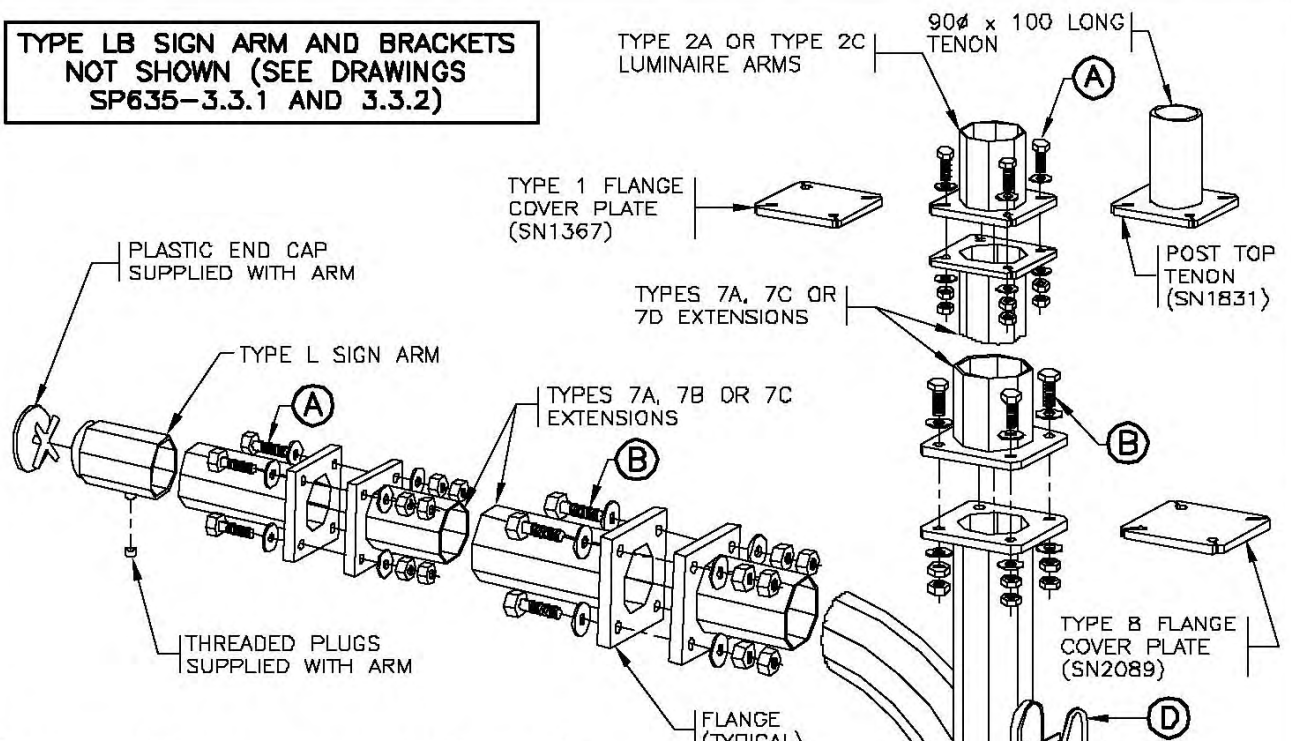

TYPE 7 SHAFT BOLT KIT (SN1792A)		
ITEM	QUANTITY	DESCRIPTION
A	8	5/8"φ x 3" LONG BOLT, 2 NUTS AND 2 WASHERS.
B	8	1"φ x 5" LONG BOLT, 2 NUTS AND 2 WASHERS.
C	1	LARGE HANDHOLE COVER WITH 2-3/8"φ x 1" LONG BOLTS AND 2 WASHERS.
D	1	SMALL HANDHOLE COVER WITH 3/8"φ x 3 1/2" LONG BOLT, WASHER AND BACKER BAR.
E	1	3/8"φ x 1 1/4" LONG BONDING BOLT WITH 1 NUT AND 2 WASHERS.
F	4	LEVELLING SHIMS.

NOTES

1. SEE STANDARD SPECIFICATIONS & SPECIAL PROVISIONS FOR ADDITIONAL INFORMATION.
2. POLE SHAFT SHALL BE INSTALLED PLUMB.
3. ALL SHAFTS, ARMS AND EXTENSIONS SHALL BE SUPPLIED WITH A GALVANIZED FINISH.
4. APPLY GREASE TO ANCHOR BOLT THREADS.
5. TOUCH UP ANY SCRATCHES IN GALVANIZED SURFACES WITH COLD GALVANIZING COMPOUND.

NOT TO SCALE

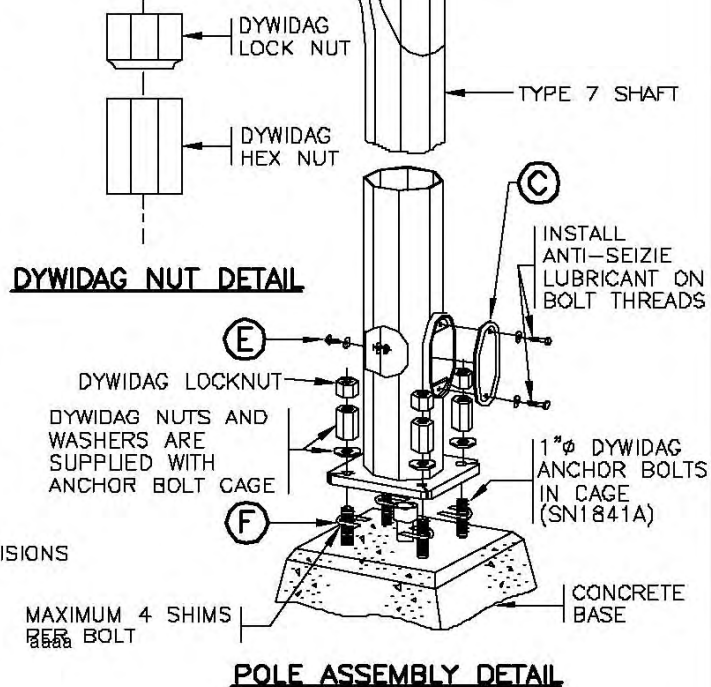

No.	Revision	Date
E		
D	ANTI-SEIZE LUBRICANT NOTED ON HANDHOLE BOLT	NOV 98
C	SMALL HANDHOLE BOLT LENGTH & DRAWING No. REV'D	AUG 96
B	END CAP SUPPLIED ON L SIGN ARM	AUG 95
A	GENERAL REVISION	AUG 94

TYPE 7 SHAFT INSTALLATION DETAILS (SIGN POLE)

Date	Approved	SPECIFICATION DRAWING No.
30/09/93	E.L. (Signature on File) Chief Highway Engineer	SP635-3.1.9

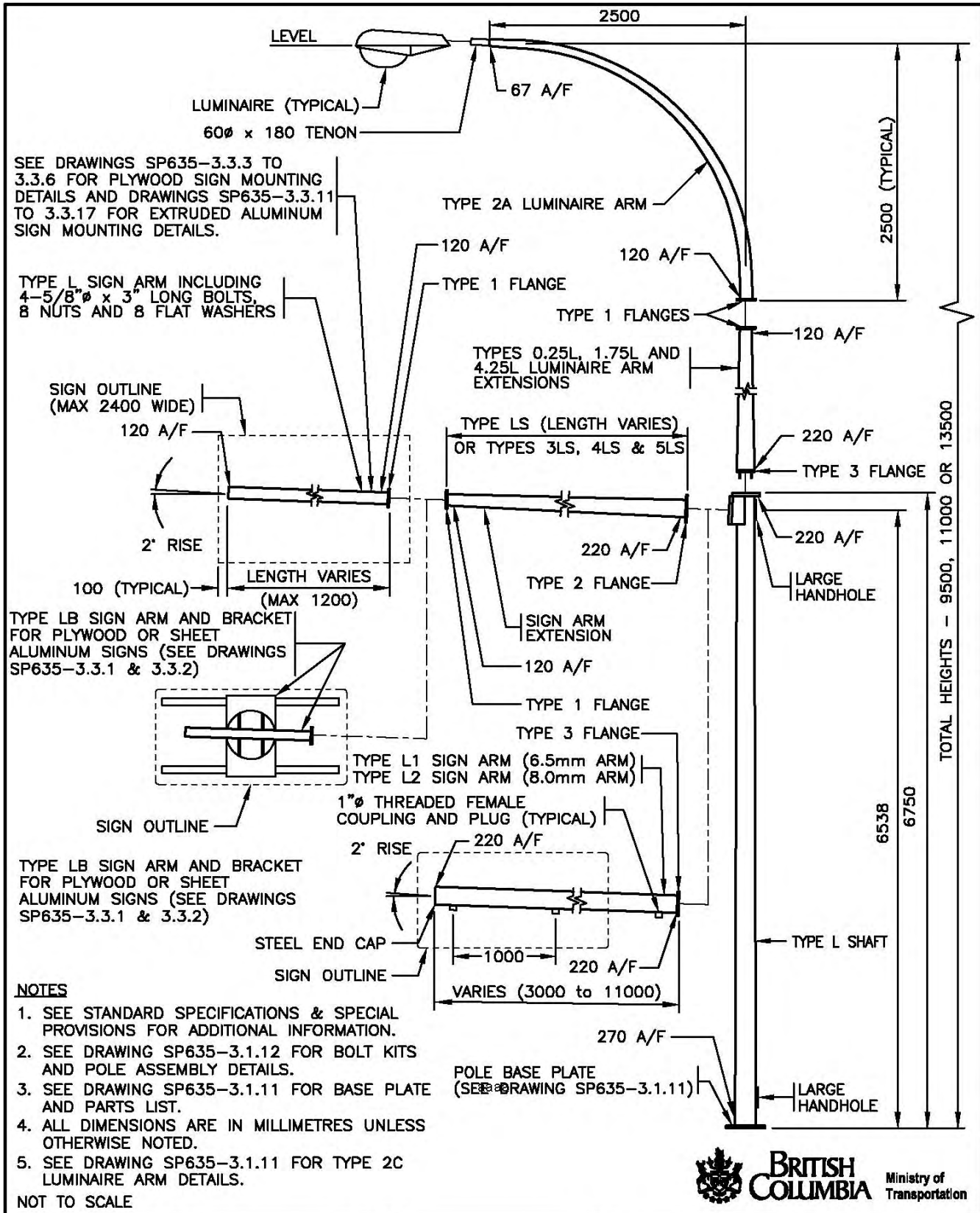

No.	Revision	Date
F		
E	SHEET ALUMINUM SIGN ADDED	APR 05
D	COUPLING DELETED ON SIGN ARM	NOV 01
C	L SIGN ARM & DWG. No. REV'D & 4LS EXT ADDED	AUG 96
B	L1/L2 SIGN ARMS & NOTE 5 ADDED	AUG 95
A	GENERAL REVISION	AUG 94

TYPE L SIGN POLE INSTALLATION DETAILS		SPECIFICATION DRAWING No.
Date	Approved	SP635-3.1.10
30/09/93	E.L. (Signature on File) Chief Highway Engineer	

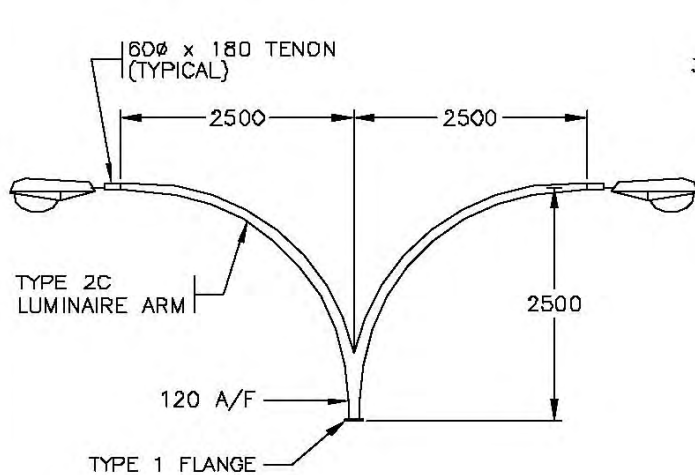

TYPE 2C LUMINAIRE ARM DETAILS

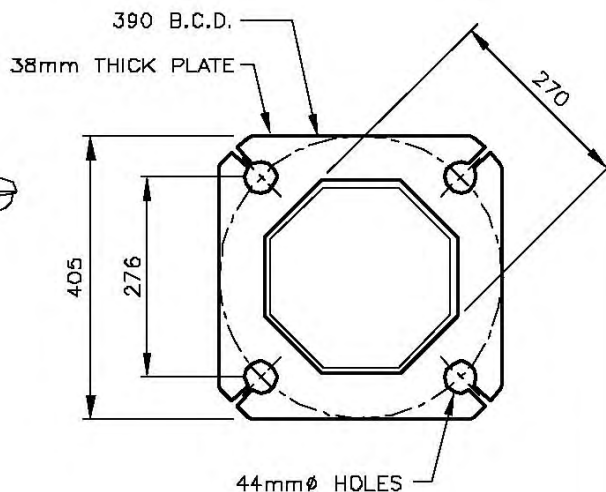

TYPE L POLE BASE PLATE

PARTS LIST FOR TYPE L SIGN POLE		
PART	MINISTRY STOCK NUMBER	MASS (kg)
TYPE [L] POLE SHAFT	SN2052	442
TYPE L SIGN ARM [LSA] LENGTH VARIES	SN2093	20 PER METRE
TYPE L SIGN ARM [1.2LSA] 1.2m LONG	SN2095	24
TYPE L1 SIGN ARM [L1SA] LENGTH VARIES	SN2095A	39 PER METRE
TYPE L2 SIGN ARM [L2SA] LENGTH VARIES	SN2095B	46 PER METRE
TYPE [LB] SIGN ARM AND BRACKETS	SN2096	100
TYPE [LS] SIGN ARM EXTENSION - LENGTH VARIES	SN2094	45 PER METRE
TYPE [3LS] SIGN ARM EXTENSION - 3.0m	SN2094A	135
TYPE [4LS] SIGN ARM EXTENSION - 4.0m	SN2094B	180
TYPE [5LS] SIGN ARM EXTENSION - 5.0m	SN2094C	225
TYPE [4.25L] LUMINAIRE ARM EXTENSION - 4.25m	SN2062	82
TYPE [1.75L] LUMINAIRE ARM EXTENSION - 1.75m	SN2063	29
TYPE [0.25L] LUMINAIRE ARM EXTENSION - 0.25m	SN2064	10
TYPE [2A] LUMINAIRE ARM	SN1832	35
TYPE [2C] LUMINAIRE ARM	SN1833	65
TYPE 1 FLANGE COVER PLATE [1FCP]	SN1367	1.5
TYPE 2 FLANGE COVER PLATE [2FCP]	SN2083	4
TYPE 3 FLANGE COVER PLATE [3FCP]	SN2084	4
POST TOP TENON [PTT]	SN1831	5

* [] I.D. LABEL ON POLE

NOT TO SCALE



No.	Revision	Date	TYPE L SIGN POLE INSTALLATION DETAILS		SPECIFICATION DRAWING No.
F			Date	Approved	SP635-3.1.11
E			30/09/93	E.L. (Signature on File)	
D			Chief Highway Engineer		
C	TYPE L SIGN ARM & DWG. No. REV'D & 4LS EXT ADDED	AUG 96			
B	L1/L2 SIGN ARMS & 2C ARM ADDED	AUG 95			
A	GENERAL REVISION	AUG 94			

TYPE LB SIGN ARM AND BRACKETS NOT SHOWN (SEE DRAWINGS SP635-3.3.1 AND 3.3.2)

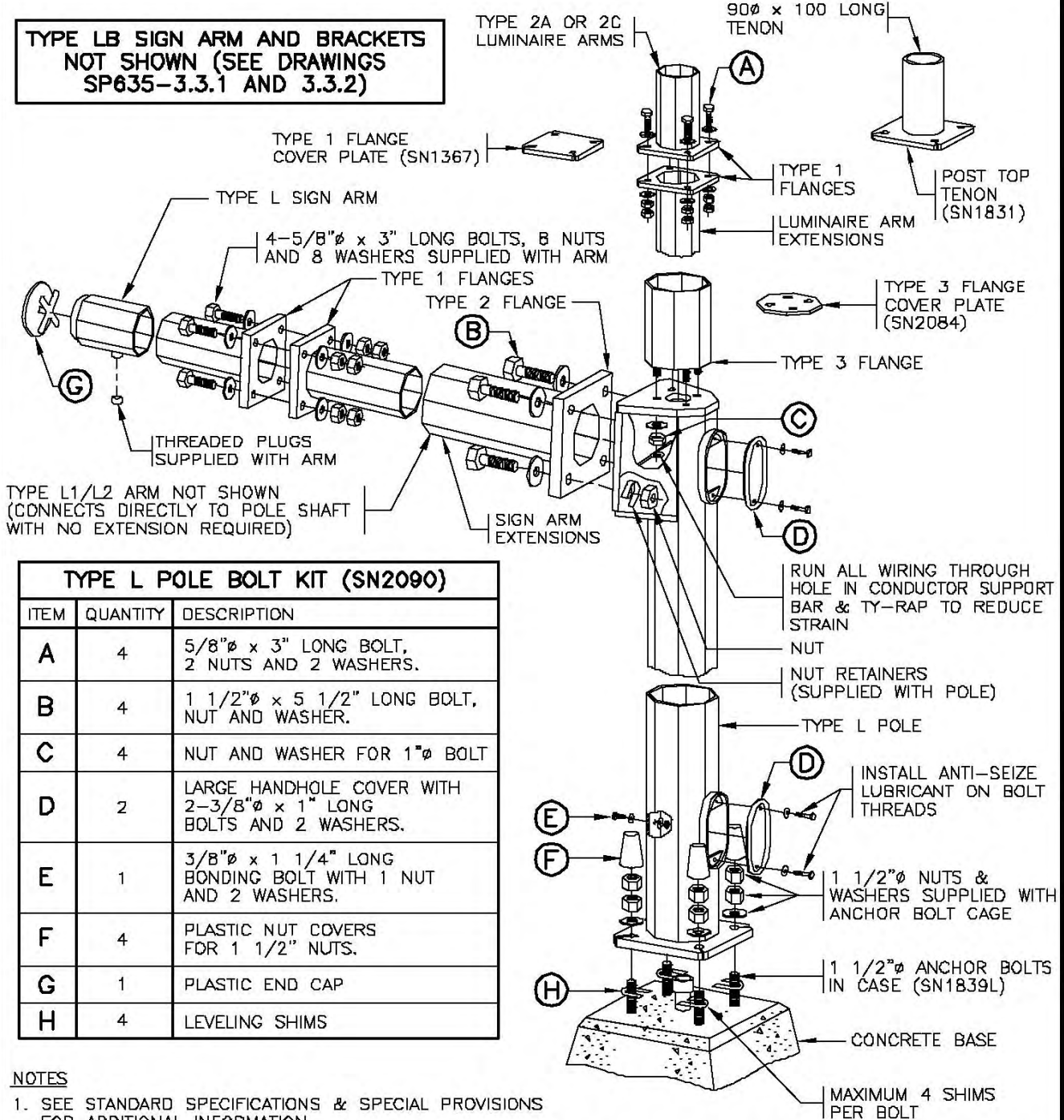

TYPE L POLE BOLT KIT (SN2090)		
ITEM	QUANTITY	DESCRIPTION
A	4	5/8"φ x 3" LONG BOLT, 2 NUTS AND 2 WASHERS.
B	4	1 1/2"φ x 5 1/2" LONG BOLT, NUT AND WASHER.
C	4	NUT AND WASHER FOR 1"φ BOLT
D	2	LARGE HANDHOLE COVER WITH 2-3/8"φ x 1" LONG BOLTS AND 2 WASHERS.
E	1	3/8"φ x 1 1/4" LONG BONDING BOLT WITH 1 NUT AND 2 WASHERS.
F	4	PLASTIC NUT COVERS FOR 1 1/2" NUTS.
G	1	PLASTIC END CAP
H	4	LEVELING SHIMS

NOTES

- SEE STANDARD SPECIFICATIONS & SPECIAL PROVISIONS FOR ADDITIONAL INFORMATION.
- POLE SHAFT SHALL BE INSTALLED PLUMB.
- ALL SHAFTS, ARMS AND EXTENSIONS SHALL BE SUPPLIED WITH A GALVANIZED FINISH.
- APPLY GREASE TO ANCHOR BOLT THREADS.
- TOUCH UP ANY SCRATCHES IN GALVANIZED SURFACES WITH COLD GALVANIZING COMPOUND.

NOT TO SCALE

POLE ASSEMBLY DETAIL



No.	Revision	Date
E		
D	ANTI-SEIZING LUBRICANT NOTED ON HANDHOLE BOLT	NOV 98
C	SIGN ARM & DRAWING NUMBERS REVISED	AUG 96
B	L ARM BOLT SIZES REVISED.	AUG 95
A	GENERAL REVISION	AUG 94

TYPE L SIGN POLE INSTALLATION DETAILS		
Date	Approved	SPECIFICATION DRAWING No.
30/09/93	E.L. (Signature on File) Chief Highway Engineer	SP635-3.1.12

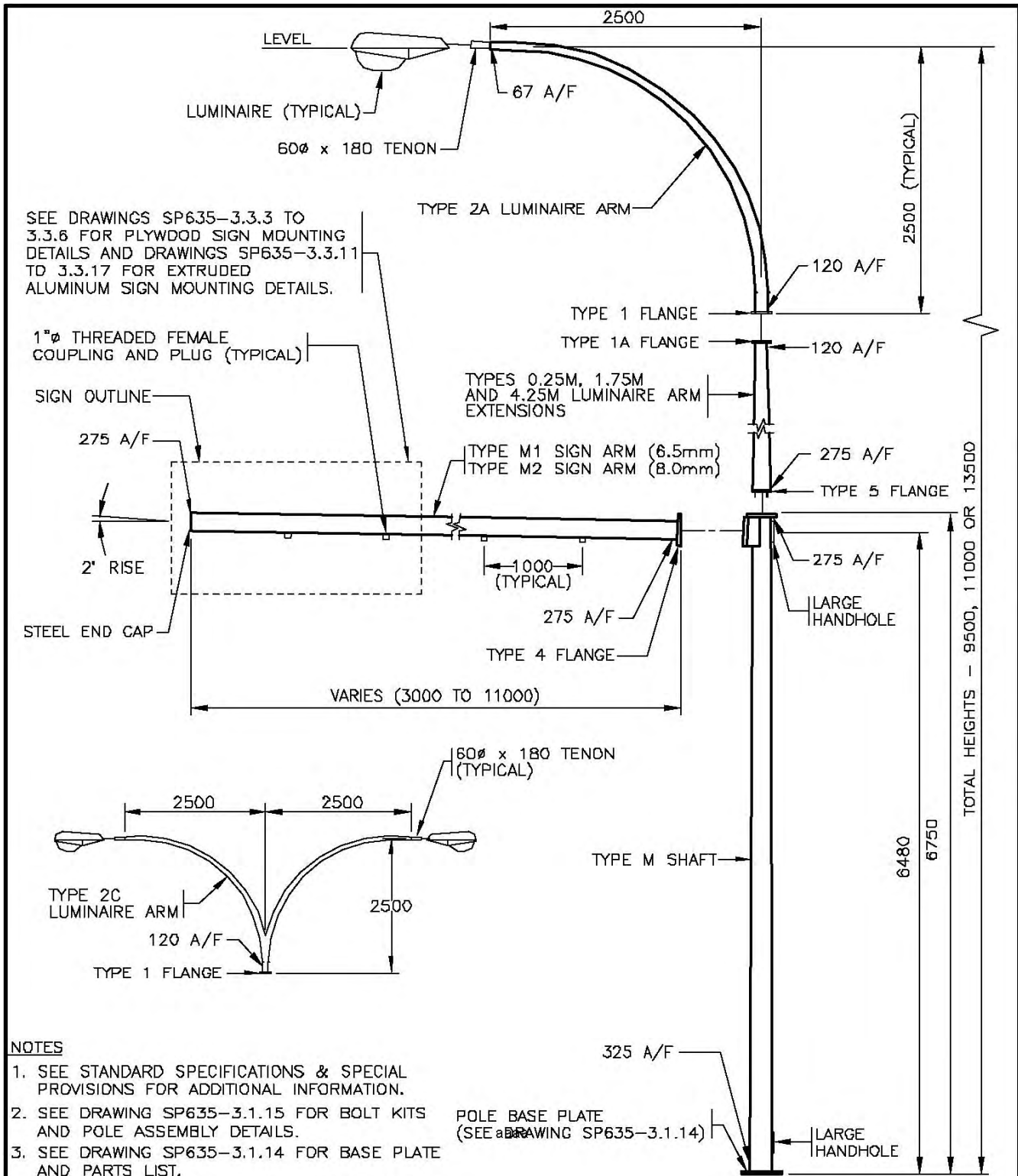

NOTES

1. SEE STANDARD SPECIFICATIONS & SPECIAL PROVISIONS FOR ADDITIONAL INFORMATION.
2. SEE DRAWING SP635-3.1.15 FOR BOLT KITS AND POLE ASSEMBLY DETAILS.
3. SEE DRAWING SP635-3.1.14 FOR BASE PLATE AND PARTS LIST.
4. ALL DIMENSIONS ARE IN MILLIMETRES UNLESS OTHERWISE NOTED.

NOT TO SCALE



No.	Revision	Date
F		
E		
D		
C		
B	DRAWING REFERENCES & DRAWING NUMBER REVISED	DEC 96
A	GENERAL REVISION	AUG 94

TYPE M SIGN POLE INSTALLATION DETAILS		
Date	Approved	SPECIFICATION DRAWING No.
30/09/93	E.L. (Signature on File) Chief Highway Engineer	SP635-3.1.13

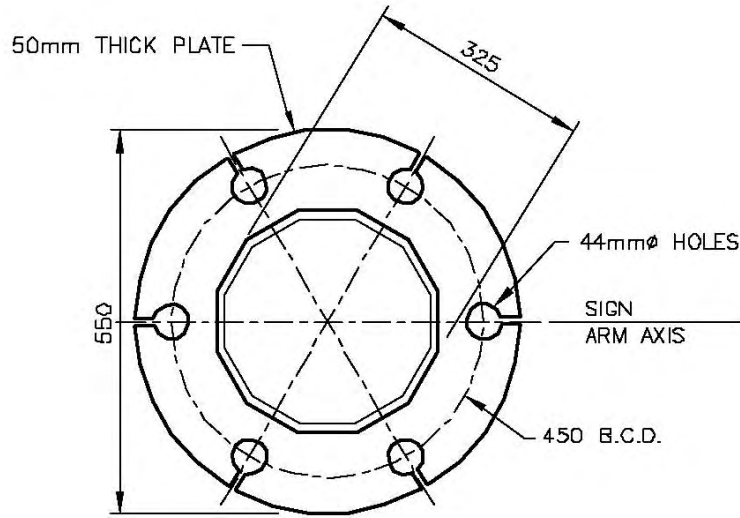

TYPE M POLE BASE PLATE

PARTS LIST FOR TYPE M SIGNAL POLE		
PART	MINISTRY STOCK NUMBER	MASS (kg)
TYPE [M] POLE SHAFT	SN2070	565
TYPE [M1] SIGN ARM (LENGTH VARIES)	SN2097	55 PER METRE
TYPE [M2] SIGN ARM (LENGTH VARIES)	SN2098	65 PER METRE
TYPE [4.25M] LUMINAIRE ARM EXTENSION - 4.25m	SN2072	115
TYPE [1.75M] LUMINAIRE ARM EXTENSION - 1.75m	SN2073	38
TYPE [0.25M] LUMINAIRE ARM EXTENSION - 0.25m	SN2074	14
TYPE [2A] LUMINAIRE ARM	SN1832	35
TYPE [2C] LUMINAIRE ARM	SN1833	65
TYPE 1 FLANGE COVER PLATE [1FCP]	SN1367	1.5
TYPE 3 FLANGE COVER PLATE [3FCP]	SN2084	4
TYPE 4 FLANGE COVER PLATE [4FCP]	SN2085	8
TYPE 5 FLANGE COVER PLATE [5FCP]	SN2086	4
TYPE 4 TO 2 FLANGE ADAPTOR [FA]	SN2080	75
POST TOP TENON [PTT]	SN1831	5

* [] I.D. LABELS ON POLE

aaaa



NOT TO SCALE

No.	Revision	Date	TYPE M SIGN POLE INSTALLATION DETAILS	
F			Date	Approved
E			30/09/93	E.L. (Signature on File)
D			Chief Highway Engineer	
C	DRAWING NUMBER REVISED	AUG 96	SPECIFICATION DRAWING No. SP635-3.1.14	
B	HOLE SIZES REVISED	AUG 95		
A	GENERAL REVISION	AUG 94		

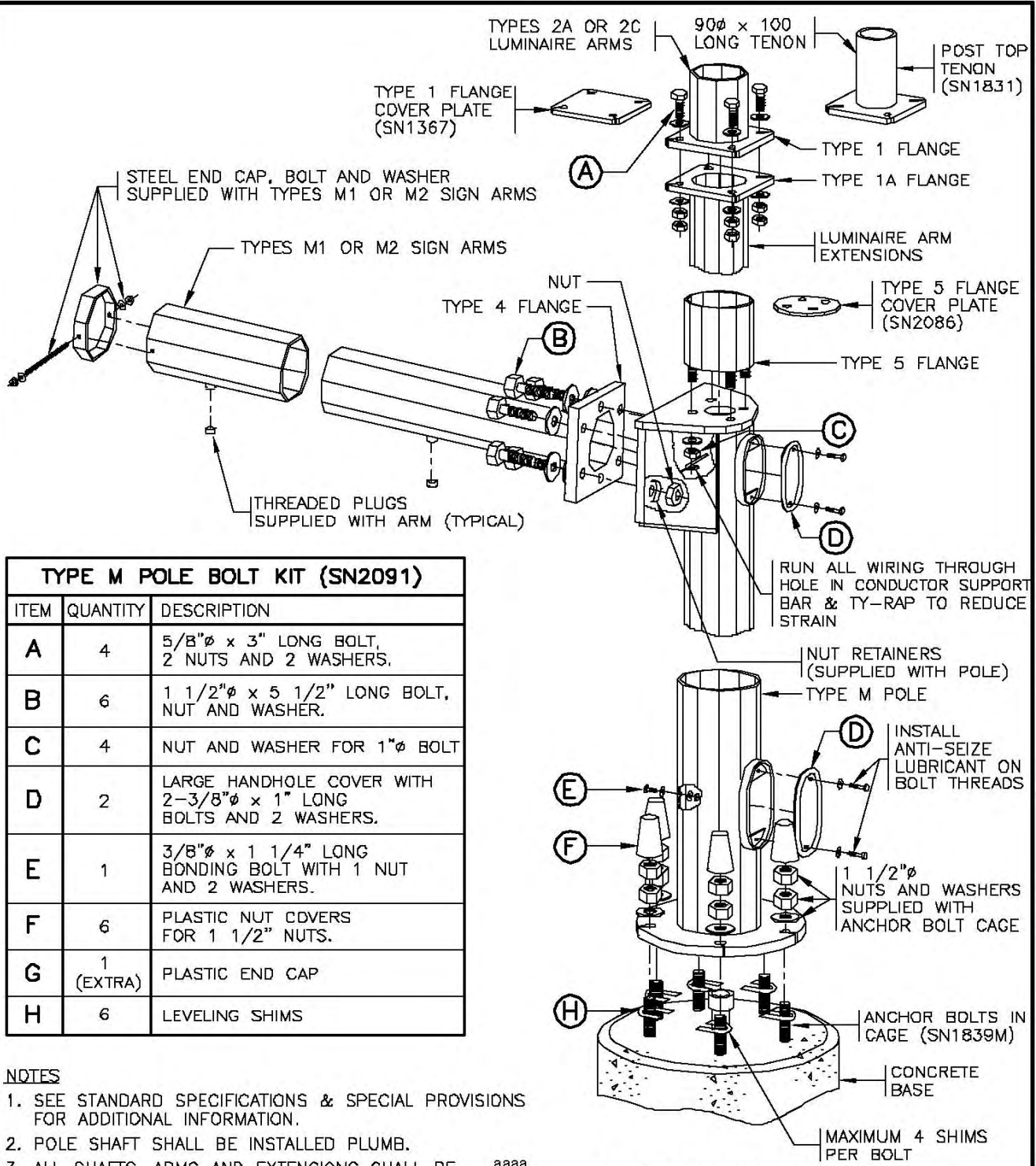

TYPE M POLE BOLT KIT (SN2091)		
ITEM	QUANTITY	DESCRIPTION
A	4	5/8"φ x 3" LONG BOLT, 2 NUTS AND 2 WASHERS.
B	6	1 1/2"φ x 5 1/2" LONG BOLT, NUT AND WASHER.
C	4	NUT AND WASHER FOR 1"φ BOLT
D	2	LARGE HANDHOLE COVER WITH 2-3/8"φ x 1" LONG BOLTS AND 2 WASHERS.
E	1	3/8"φ x 1 1/4" LONG BONDING BOLT WITH 1 NUT AND 2 WASHERS.
F	6	PLASTIC NUT COVERS FOR 1 1/2" NUTS.
G	1 (EXTRA)	PLASTIC END CAP
H	6	LEVELING SHIMS

NOTES

- SEE STANDARD SPECIFICATIONS & SPECIAL PROVISIONS FOR ADDITIONAL INFORMATION.
- POLE SHAFT SHALL BE INSTALLED PLUMB.
- ALL SHAFTS, ARMS AND EXTENSIONS SHALL BE SUPPLIED WITH A GALVANIZED FINISH.
- APPLY GREASE TO ANCHOR BOLT THREADS.
- TOUCH UP ANY SCRATCHES IN GALVANIZED SURFACES WITH COLD GALVANIZING COMPOUND.

NOT TO SCALE

POLE ASSEMBLY DETAIL



No.	Revision	Date
E		
D	ANTI-SEIZING LUBRICANT NOTED ON HANDHOLE BOLT	NOV 98
C	BOLT KIT LIST & DWG. No. REV'D & CONDUCTOR SUPPORT ADDED	AUG 96
B	HANDHOLE BOLT SIZE REVISED	AUG 95
A	GENERAL REVISION	AUG 94

TYPE M SIGN POLE INSTALLATION DETAILS		
Date	Approved	SPECIFICATION DRAWING No.
30/09/93	E.L. (Signature on File) Chief Highway Engineer	SP635-3.1.15

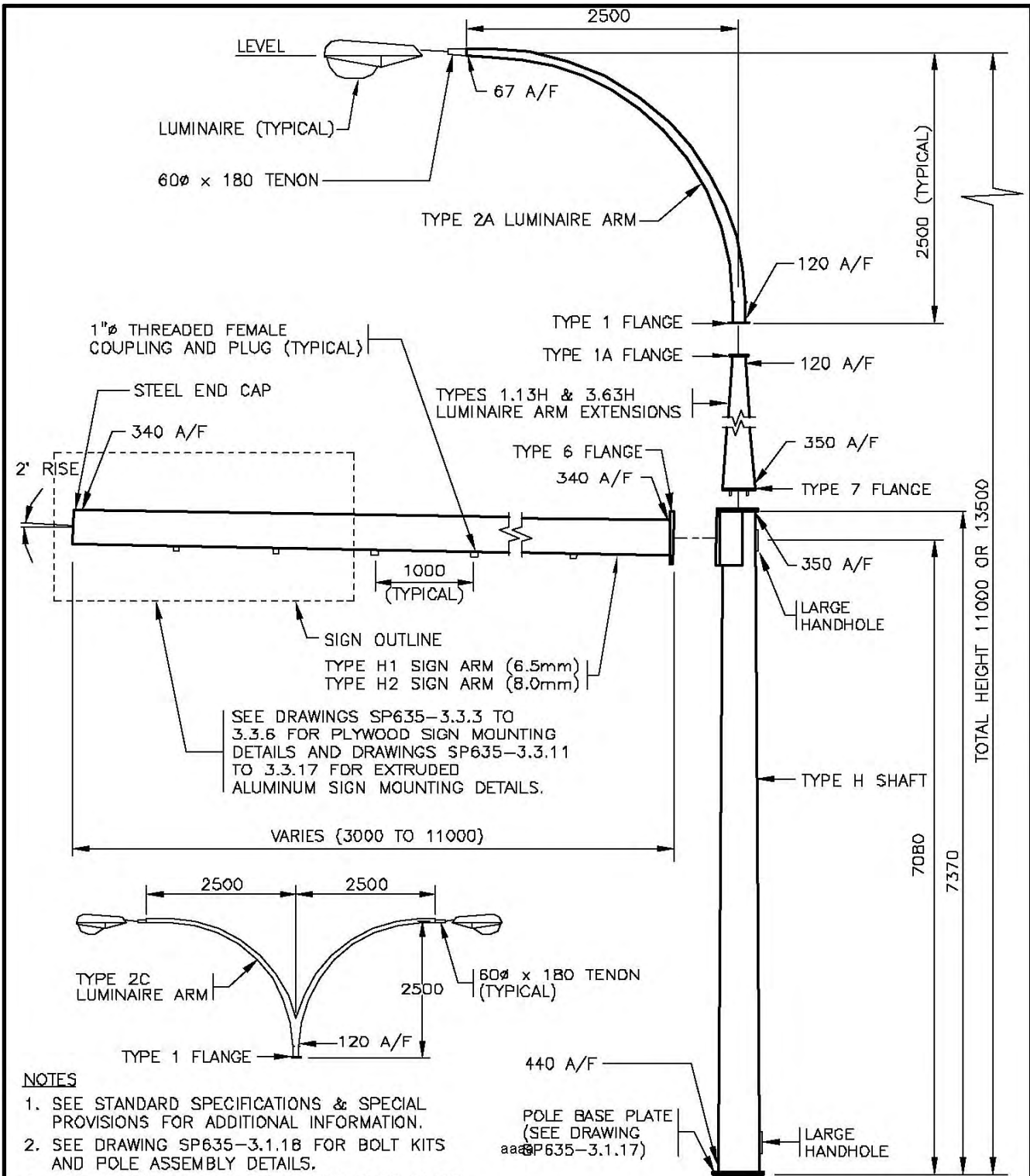

NOTES

1. SEE STANDARD SPECIFICATIONS & SPECIAL PROVISIONS FOR ADDITIONAL INFORMATION.
2. SEE DRAWING SP635-3.1.18 FOR BOLT KITS AND POLE ASSEMBLY DETAILS.
3. SEE DRAWING SP635-3.1.17 FOR BASE PLATE AND PARTS LIST.
4. ALL DIMENSIONS ARE IN MILLIMETRES UNLESS OTHERWISE NOTED.

NOT TO SCALE



No.	Revision	Date
F		
E		
D		
C		
B	DRAWING NUMBER & DRAWING REFERENCES REVISED	DEC 96
A	GENERAL REVISION	AUG 94

TYPE H SIGN POLE INSTALLATION DETAILS		
Date	Approved	SPECIFICATION DRAWING No.
30/09/93	E.L. (Signature on File) Chief Highway Engineer	SP635-3.1.16

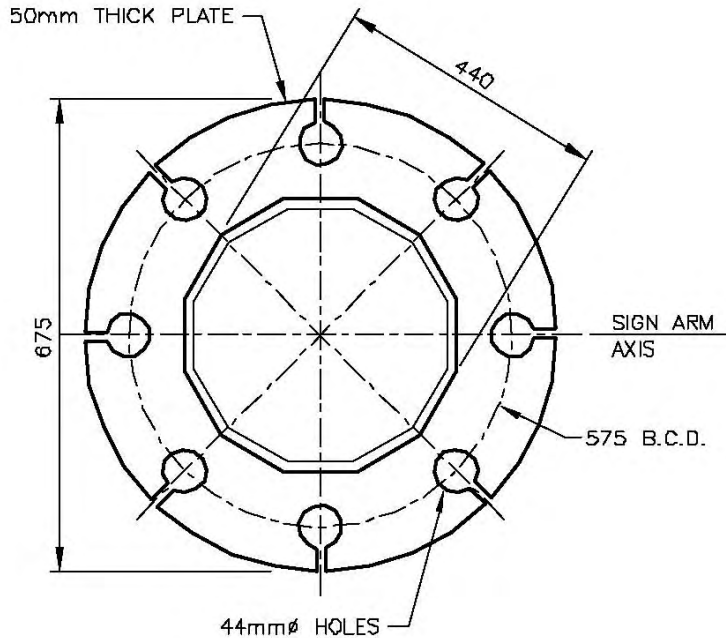

TYPE H POLE BASE PLATE

PARTS LIST FOR TYPE H SIGNAL POLE		
PART	MINISTRY STOCK NUMBER	MASS (kg)
TYPE [H] POLE SHAFT	SN2077	870
TYPE [H1] SIGN ARM (LENGTH VARIES)	SN2099	73 PER METRE
TYPE [H2] SIGN ARM (LENGTH VARIES)	SN2100	86 PER METRE
TYPE [3.63H] LUMINAIRE ARM EXTENSION - 3.63m	SN2078	118
TYPE [1.13H] LUMINAIRE ARM EXTENSION - 1.13m	SN2079	36
TYPE [2A] LUMINAIRE ARM	SN1832	35
TYPE [2C] LUMINAIRE ARM	SN1833	65
TYPE 1 FLANGE COVER PLATE [1FCP]	SN1367	1.5
TYPE 6 FLANGE COVER PLATE [6FCP]	SN2087	12
TYPE 7 FLANGE COVER PLATE [7FCP]	SN2088	6
POST TOP TENDON [PTT]	SN1831	5

* [] I.D. LABEL ON POLE

aaaa

NOT TO SCALE



No.	Revision	Date	TYPE H SIGN POLE INSTALLATION DETAILS		SPECIFICATION DRAWING No.
F			Date	Approved	SP635-3.1.17
E			30/09/93	E.L. (Signature on File)	
D				Chief Highway Engineer	
C	DRAWING NUMBER REVISED	AUG 96			
B	HOLE SIZE REVISED	AUG 95			
A	GENERAL REVISION	AUG 94			

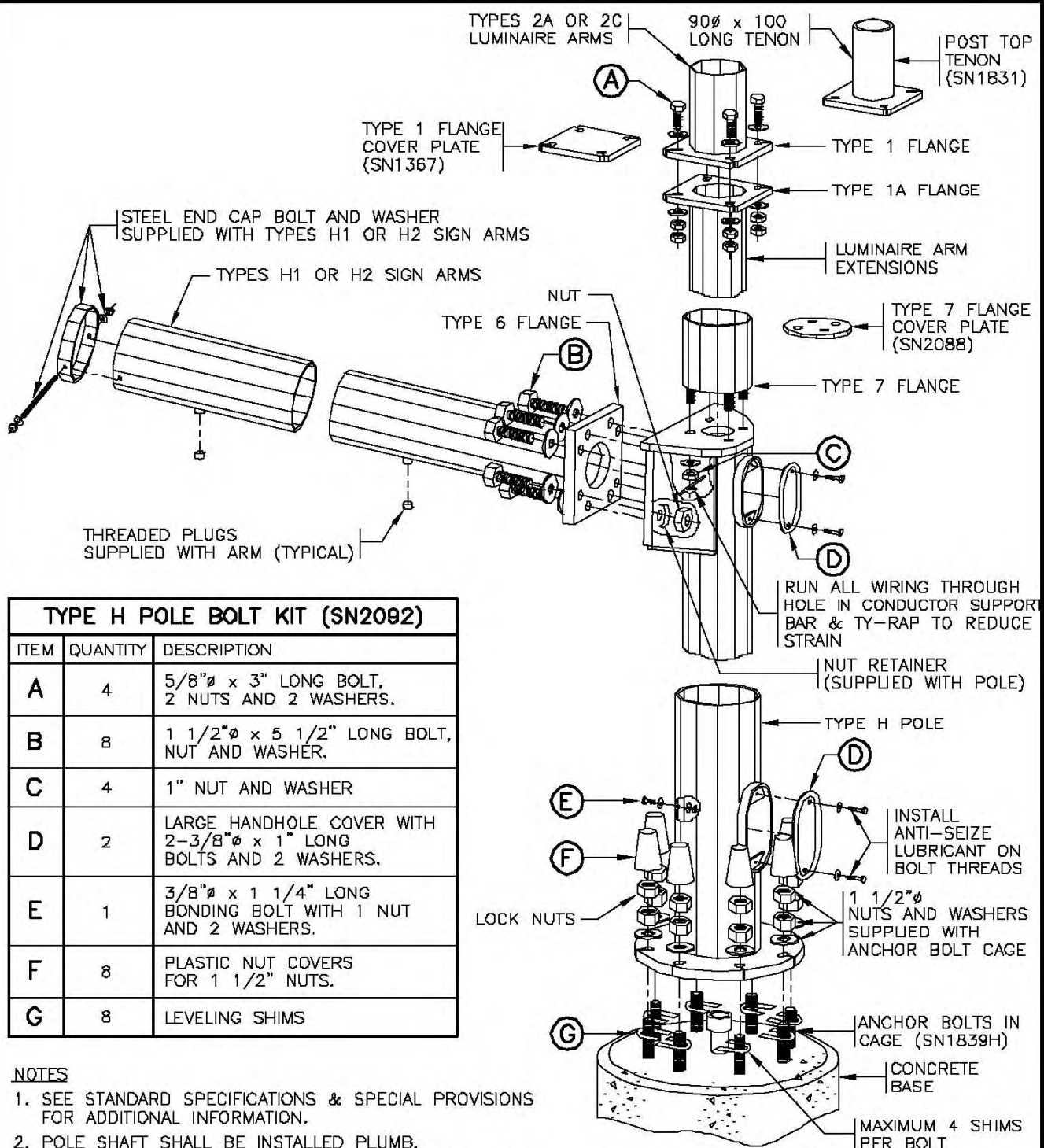

TYPE H POLE BOLT KIT (SN2092)		
ITEM	QUANTITY	DESCRIPTION
A	4	5/8"Ø x 3" LONG BOLT, 2 NUTS AND 2 WASHERS.
B	8	1 1/2"Ø x 5 1/2" LONG BOLT, NUT AND WASHER.
C	4	1" NUT AND WASHER
D	2	LARGE HANDHOLE COVER WITH 2-3/8"Ø x 1" LONG BOLTS AND 2 WASHERS.
E	1	3/8"Ø x 1 1/4" LONG BONDING BOLT WITH 1 NUT AND 2 WASHERS.
F	8	PLASTIC NUT COVERS FOR 1 1/2" NUTS.
G	8	LEVELING SHIMS

- NOTES**
- SEE STANDARD SPECIFICATIONS & SPECIAL PROVISIONS FOR ADDITIONAL INFORMATION.
 - POLE SHAFT SHALL BE INSTALLED PLUMB.
 - ALL SHAFTS, ARMS AND EXTENSIONS SHALL BE SUPPLIED WITH A GALVANIZED FINISH.
 - APPLY GREASE TO ANCHOR BOLT THREADS.
 - TOUCH UP ANY SCRATCHES IN GALVANIZED SURFACES WITH COLD GALVANIZING COMPOUND.

NOT TO SCALE

POLE ASSEMBLY DETAIL



No.	Revision	Date
E		
D	ANTI-SEIZE LUBRICANT NOTED ON HANDHOLE BOLT	NOV 98
C	DRAWING NUMBER REVISED & CONDUCTOR SUPPORT ADDED	AUG 96
B	HANDHOLE BOLT SIZE REVISED	AUG 95
A	GENERAL REVISION	AUG 94

TYPE H SIGN POLE INSTALLATION DETAILS		
Date	Approved	SPECIFICATION DRAWING No.
30/09/93	E.L. (Signature on File) Chief Highway Engineer	SP635-3.1.18

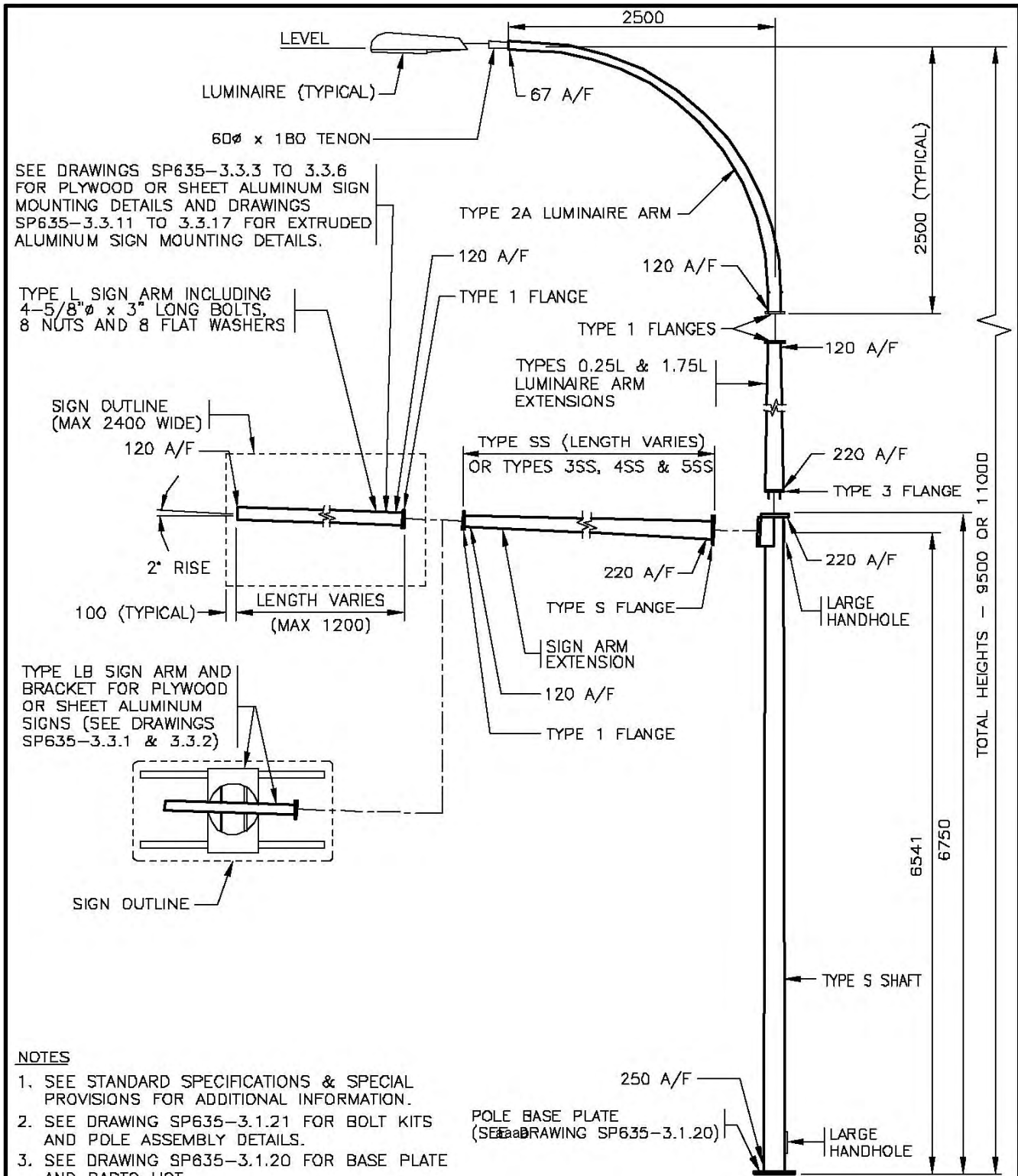

SEE DRAWINGS SP635-3.3.3 TO 3.3.6 FOR PLYWOOD OR SHEET ALUMINUM SIGN MOUNTING DETAILS AND DRAWINGS SP635-3.3.11 TO 3.3.17 FOR EXTRUDED ALUMINUM SIGN MOUNTING DETAILS.

TYPE L SIGN ARM INCLUDING 4-5/8" Ø x 3" LONG BOLTS, 8 NUTS AND 8 FLAT WASHERS

TYPE LB SIGN ARM AND BRACKET FOR PLYWOOD OR SHEET ALUMINUM SIGNS (SEE DRAWINGS SP635-3.3.1 & 3.3.2)

NOTES

1. SEE STANDARD SPECIFICATIONS & SPECIAL PROVISIONS FOR ADDITIONAL INFORMATION.
2. SEE DRAWING SP635-3.1.21 FOR BOLT KITS AND POLE ASSEMBLY DETAILS.
3. SEE DRAWING SP635-3.1.20 FOR BASE PLATE AND PARTS LIST.
4. ALL DIMENSIONS ARE IN MILLIMETRES UNLESS OTHERWISE NOTED.

NOT TO SCALE



No.	Revision	Date	TYPE S SIGN POLE INSTALLATION DETAILS		SPECIFICATION DRAWING No. SP635-3.1.19
F			Date	Approved	
E			14/11/03	D.N. (Signature on File)	
D				Chief Engineer	
C					
B					
A	SHEET ALUMINUM SIGN ADDED	APR 05			

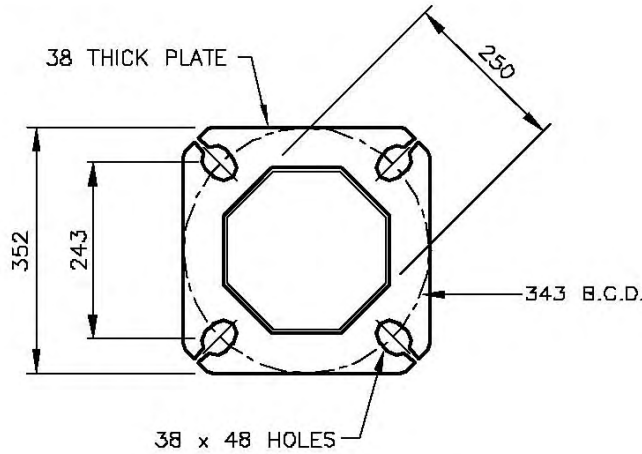

TYPE S POLE BASE PLATE
1:10

PARTS LIST FOR TYPE S SIGN POLE		
PART	MINISTRY STOCK NUMBER	MASS (kg)
TYPE [S] POLE SHAFT	SN3152	385
TYPE L SIGN ARM [LSA] LENGTH VARIES	SN2095	20 PER METRE
TYPE L SIGN ARM [1.2LSA] 1.2m LONG	SN2093	24
TYPE [LB] SIGN ARM AND BRACKETS	SN2096	100
TYPE [SS] SIGN ARM EXTENSION - LENGTH VARIES	SN3090	45 PER METRE
TYPE [3SS] SIGN ARM EXTENSION - 3.0m	SN3093	135
TYPE [4SS] SIGN ARM EXTENSION - 4.0m	SN3094	180
TYPE [5SS] SIGN ARM EXTENSION - 5.0m	SN3095	225
TYPE [1.75L] LUMINAIRE ARM EXTENSION - 1.75m	SN2063	29
TYPE [0.25L] LUMINAIRE ARM EXTENSION - 0.25m	SN2064	10
TYPE [2A] LUMINAIRE ARM	SN1832	35
TYPE 1 FLANGE COVER PLATE [1FCP]	SN1367	1.5
TYPE S FLANGE COVER PLATE [SFCP]	SN1368	3
TYPE 3 FLANGE COVER PLATE [3FCP]	SN2084	4
POST TOP TENON [PTT]	SN1831	5

* [] I.D. LABEL ON POLE

aaaa



NOT TO SCALE

No.	Revision	Date	TYPE S SIGN POLE INSTALLATION DETAILS	
F			Date	Approved
E			14/11/03	D.N. (Signature on File)
D				Chief Engineer
C				SPECIFICATION DRAWING No.
B				SP635-3.1.20
A				

TYPE LB SIGN ARM AND BRACKETS NOT SHOWN (SEE DRAWINGS SP635-3.3.1 AND 3.3.2)

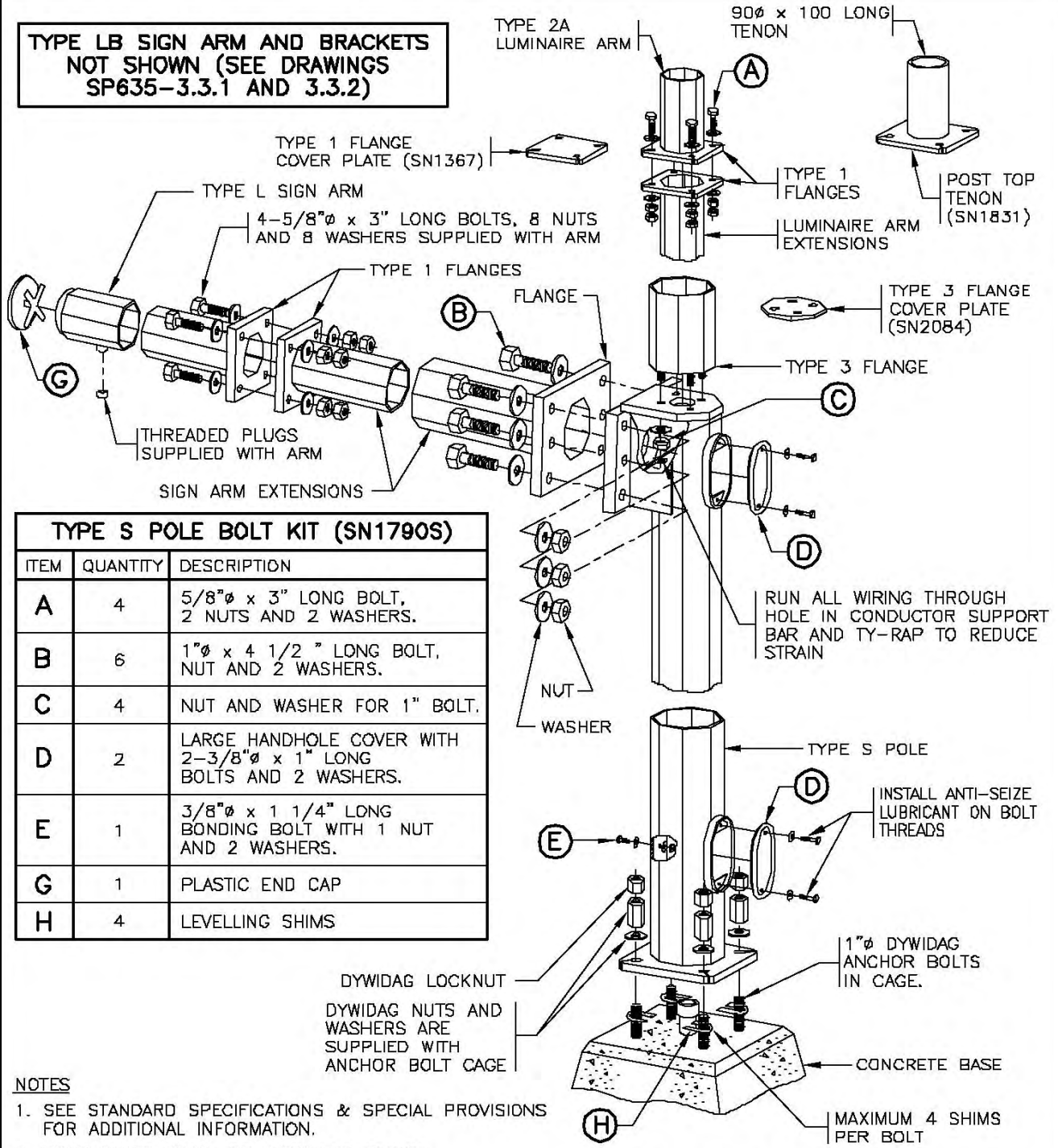

TYPE S POLE BOLT KIT (SN1790S)

ITEM	QUANTITY	DESCRIPTION
A	4	5/8"ø x 3" LONG BOLT, 2 NUTS AND 2 WASHERS.
B	6	1"ø x 4 1/2" LONG BOLT, NUT AND 2 WASHERS.
C	4	NUT AND WASHER FOR 1" BOLT.
D	2	LARGE HANDHOLE COVER WITH 2-3/8"ø x 1" LONG BOLTS AND 2 WASHERS.
E	1	3/8"ø x 1 1/4" LONG BONDING BOLT WITH 1 NUT AND 2 WASHERS.
G	1	PLASTIC END CAP
H	4	LEVELLING SHIMS

- NOTES**
1. SEE STANDARD SPECIFICATIONS & SPECIAL PROVISIONS FOR ADDITIONAL INFORMATION.
 2. POLE SHAFT SHALL BE INSTALLED PLUMB.
 3. ALL SHAFTS, ARMS AND EXTENSIONS SHALL BE SUPPLIED WITH A GALVANIZED FINISH.
 4. APPLY GREASE TO ANCHOR BOLT THREADS.
 5. TOUCH UP ANY SCRATCHES IN GALVANIZED SURFACES WITH COLD GALVANIZING COMPOUND.

NOT TO SCALE

POLE ASSEMBLY DETAIL



No.	Revision	Date
F		
E		
D		
C		
B		
A		

TYPE S SIGN POLE INSTALLATION DETAILS

Date: **14/11/03** Approved: **D.N. (Signature on File)**
 Chief Engineer

SPECIFICATION DRAWING No. **SP635-3.1.21**

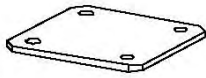

TYPE 1 & 1A FLANGE COVER PLATE
SN1367

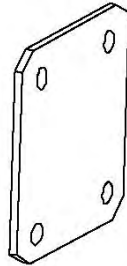

TYPE 2 FLANGE COVER PLATE
SN2083

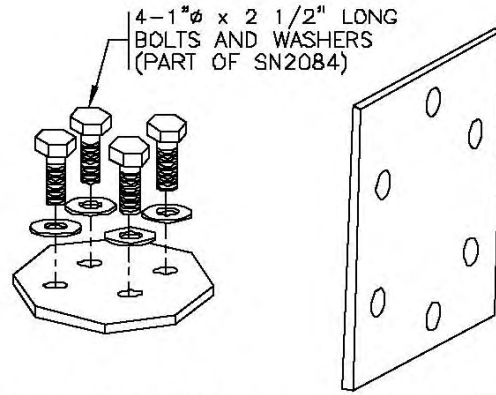

TYPE 3 FLANGE COVER PLATE
SN2084

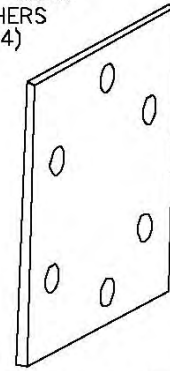

TYPE 4 FLANGE COVER PLATE
SN2085

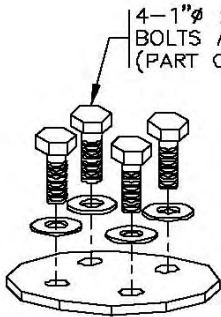

TYPE 5 FLANGE COVER PLATE
SN2086

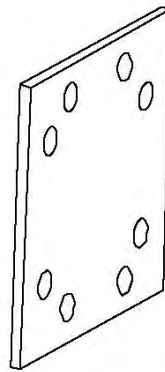

TYPE 6 FLANGE COVER PLATE
SN2087

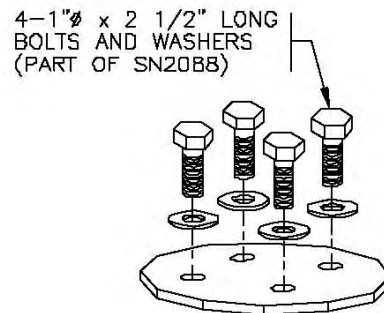

TYPE 7 FLANGE COVER PLATE
SN2088

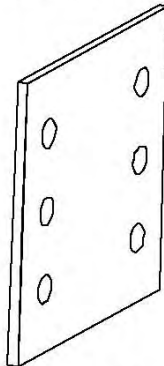

TYPE S FLANGE COVER PLATE
SN1368

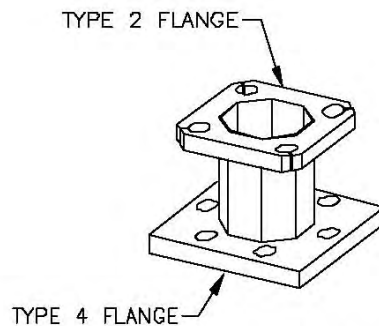

TYPE 4 TO TYPE 2 FLANGE ADAPTOR
SN2080

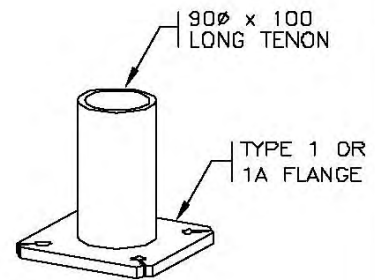

POST TOP TENON
SN1831

NOTES

1. SEE STANDARD SPECIFICATIONS & SPECIAL PROVISIONS FOR ADDITIONAL INFORMATION.

NOT TO SCALE



No.	Revision	Date
F		
E		
D		
C		
B		
A	TYPE S FLANGE COVER PLATE ADDED	OCT 03

SIGN POLE ACCESSORIES

Date: **14/11/03**
Approved: **D.N. (Signature on File)**
Chief Engineer

SPECIFICATION DRAWING No. **SP635-3.1.22**

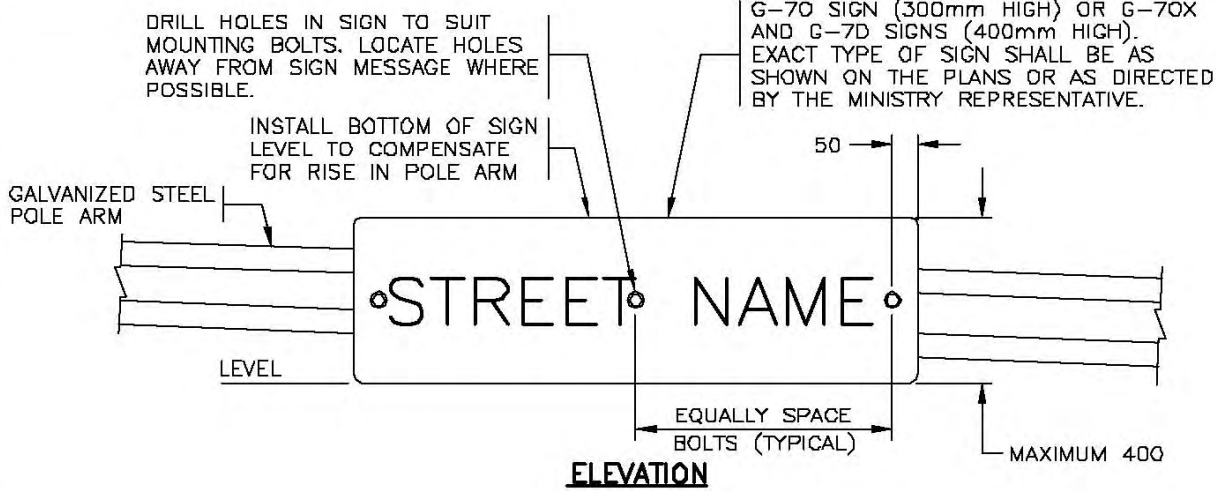

SIGN WIDTH	NUMBER OF BOLTS
900 WIDE	3
1200 WIDE	4
1500 WIDE	5
1800 WIDE	6
2100 WIDE	7

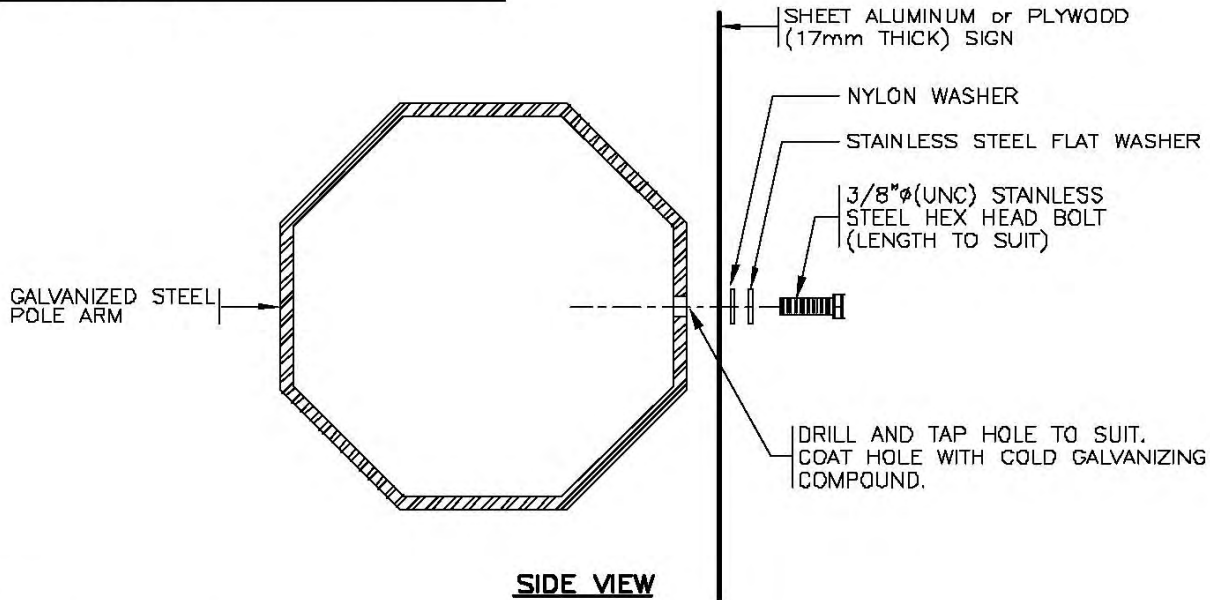

NOTES

1. SEE STANDARD SPECIFICATIONS & SPECIAL PROVISIONS FOR ADDITIONAL INFORMATION. aaaa
2. POSITION SIGN ON POLE ARM AS INDICATED ON THE PLANS OR AS DIRECTED BY THE MINISTRY REPRESENTATIVE.
3. ALL DIMENSIONS ARE IN MILLIMETRES UNLESS OTHERWISE NOTED.

NOT TO SCALE



No.	Revision	Date
F		
E		
D		
C	GENERAL REVISIONS	AUG 96
B	SIGN NUMBER AND SIZES REVISED	AUG 95
A	GENERAL REVISION	AUG 94

**OVERHEAD STREETNAME SIGN INSTALLATION
DETAILS (ON SIGNAL POLE ARMS)**

Date **30/09/93** Approved **E.L. (Signature on File)**
Chief Highway Engineer

SPECIFICATION
DRAWING No.
SP635-3.2.1

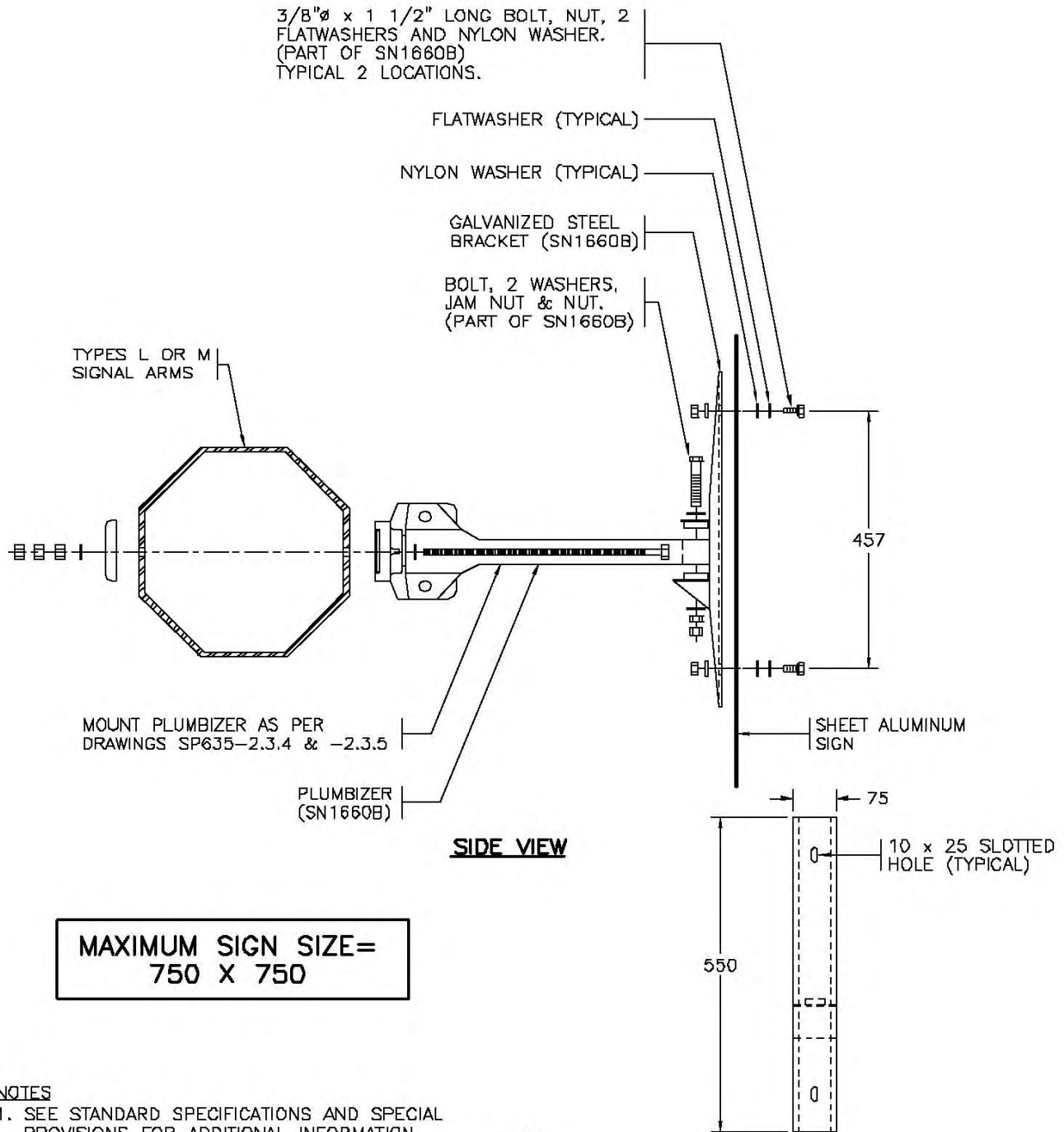

**MAXIMUM SIGN SIZE =
750 X 750**

NOTES

1. SEE STANDARD SPECIFICATIONS AND SPECIAL PROVISIONS FOR ADDITIONAL INFORMATION.
2. ALL DIMENSIONS ARE IN MILLIMETRES UNLESS OTHERWISE NOTED.
3. AIM AS DIRECTED BY THE MINISTRY REPRESENTATIVE.

NOT TO SCALE



No.	Revision	Date
F		
E		
D		
C	NYLOCK NUT REMOVED. NUT ADDED	AUG 99
B	REFERENCED DWG Nos. REVISED	DEC 98
A	PLUMBIZER BOLTING REVISED	AUG 95

**SMALL OVERHEAD SIGN INSTALLATION
DETAILS (ON TYPE L & M SIGNAL POLES)**

Date	Approved	SPECIFICATION DRAWING No.
18/11/94	E.L. (Signature on File) Chief Highway Engineer	SP635-3.2.2

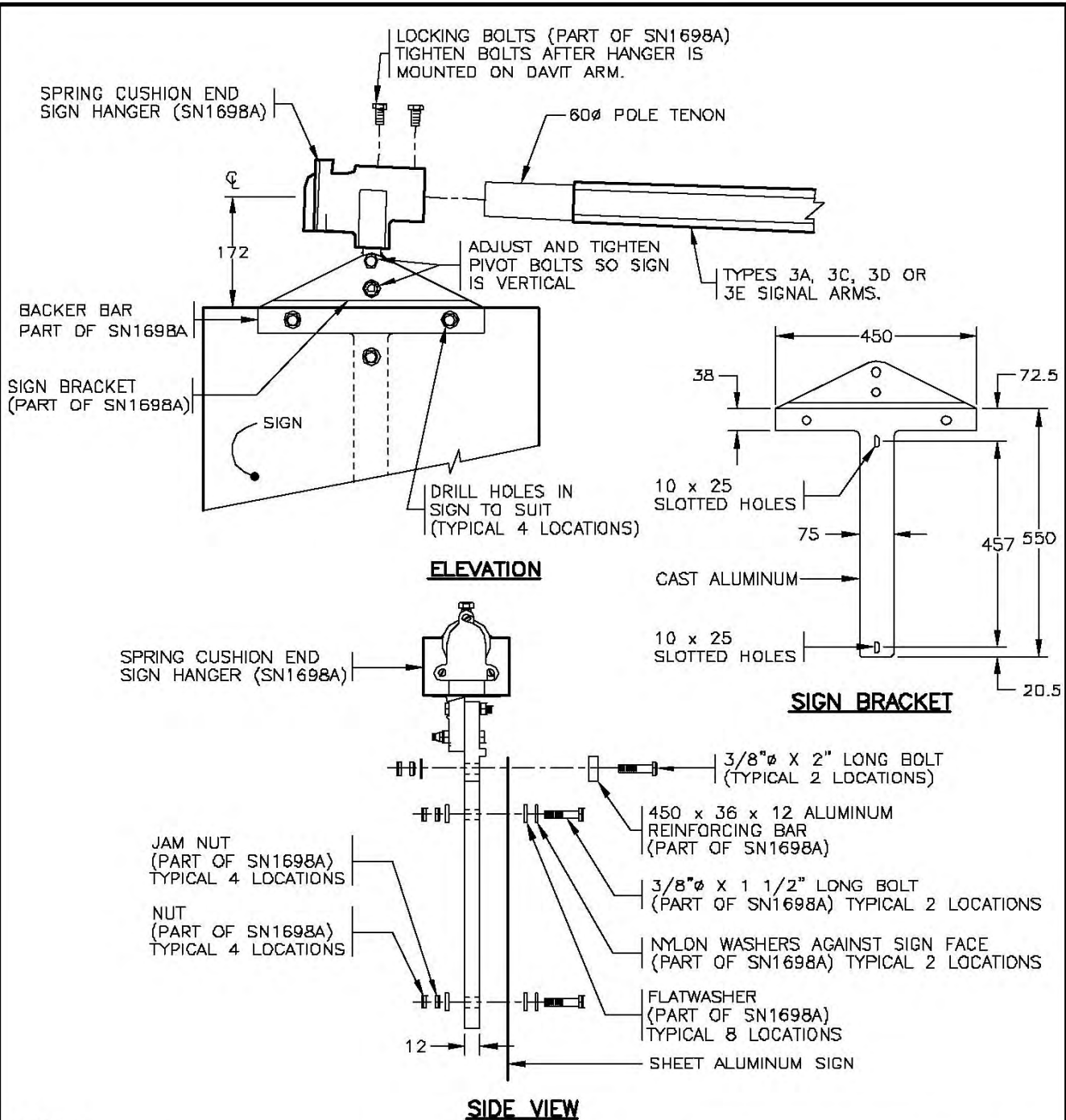

MAXIMUM SIGN SIZE = 750 X 750

NOTES

1. SEE STANDARD SPECIFICATIONS & SPECIAL PROVISIONS FOR ADDITIONAL INFORMATION.
2. AIM SIGNS AS DIRECTED BY THE MINISTRY REPRESENTATIVE.
3. 'SN' DENOTES MINISTRY STOCK NUMBER.
4. ALL DIMENSIONS ARE IN MILLIMETRES UNLESS OTHERWISE NOTED.

aaaa

NOT TO SCALE



No.	Revision	Date
F		
E		
D		
C	NYLOCK NUT REMOVED. NUT ADDED	AUG 99
B	SIGN BOLTING TO BRACKET MODIFIED	AUG 95
A	GENERAL REVISION	AUG 94

SMALL OVERHEAD SIGN INSTALLATION DETAILS (ON TYPE 3 SIGNAL ARMS)

Date **30/09/93** Approved **E.L. (Signature on File)**
Chief Highway Engineer

SPECIFICATION DRAWING No. **SP635-3.2.3**

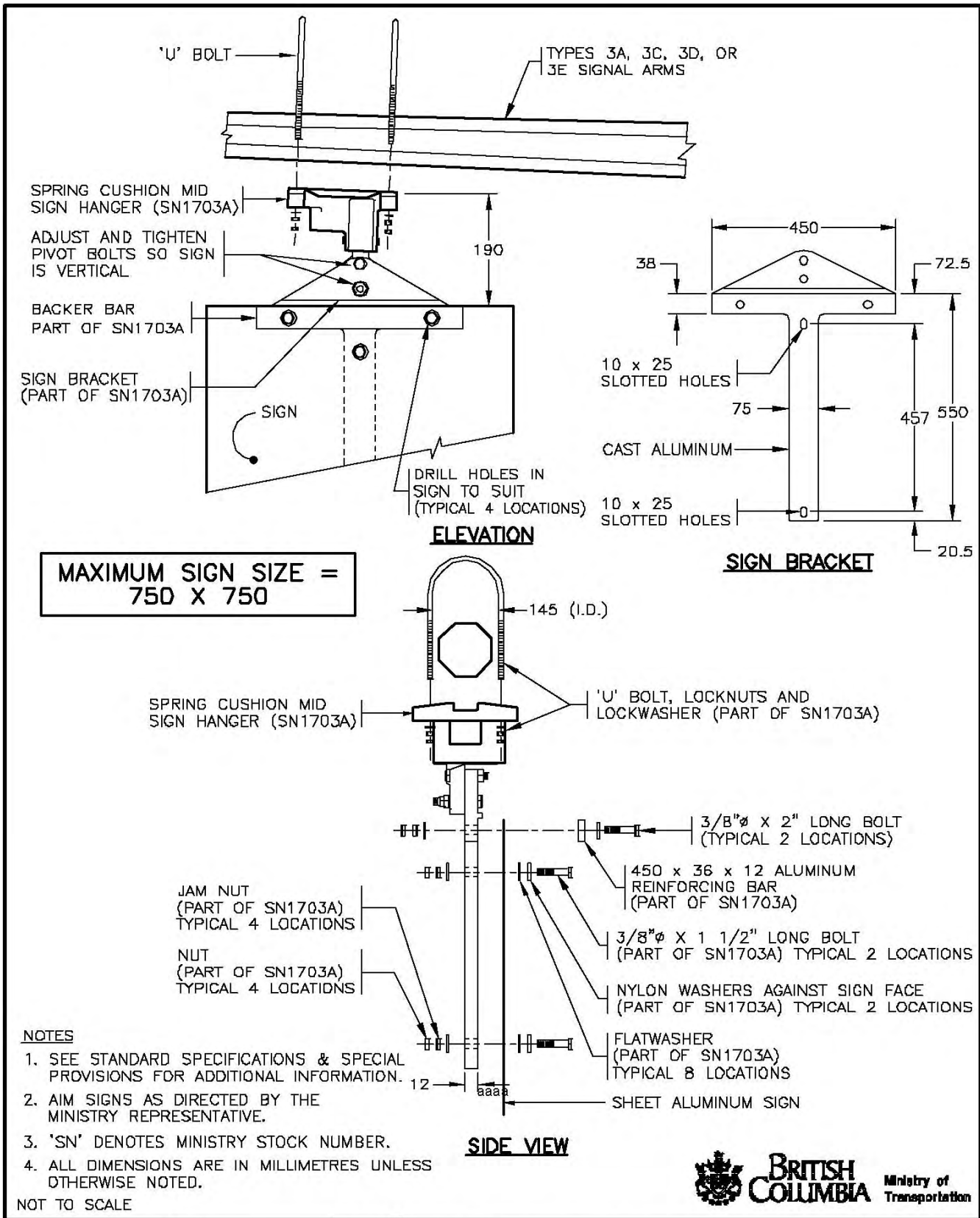

No.	Revision	Date
F		
E		
D		
C	NYLOCK NUT REMOVED. NUT ADDED	AUG 99
B	SIGN BOLTING TO BRACKET MODIFIED	AUG 95
A	GENERAL REVISION	AUG 94

**SMALL OVERHEAD SIGN INSTALLATION
DETAILS (ON TYPE 3 SIGNAL ARMS)**

Date	Approved	SPECIFICATION DRAWING No.
30/09/93	E.L. (Signature on File) Chief Highway Engineer	SP635-3.2.4

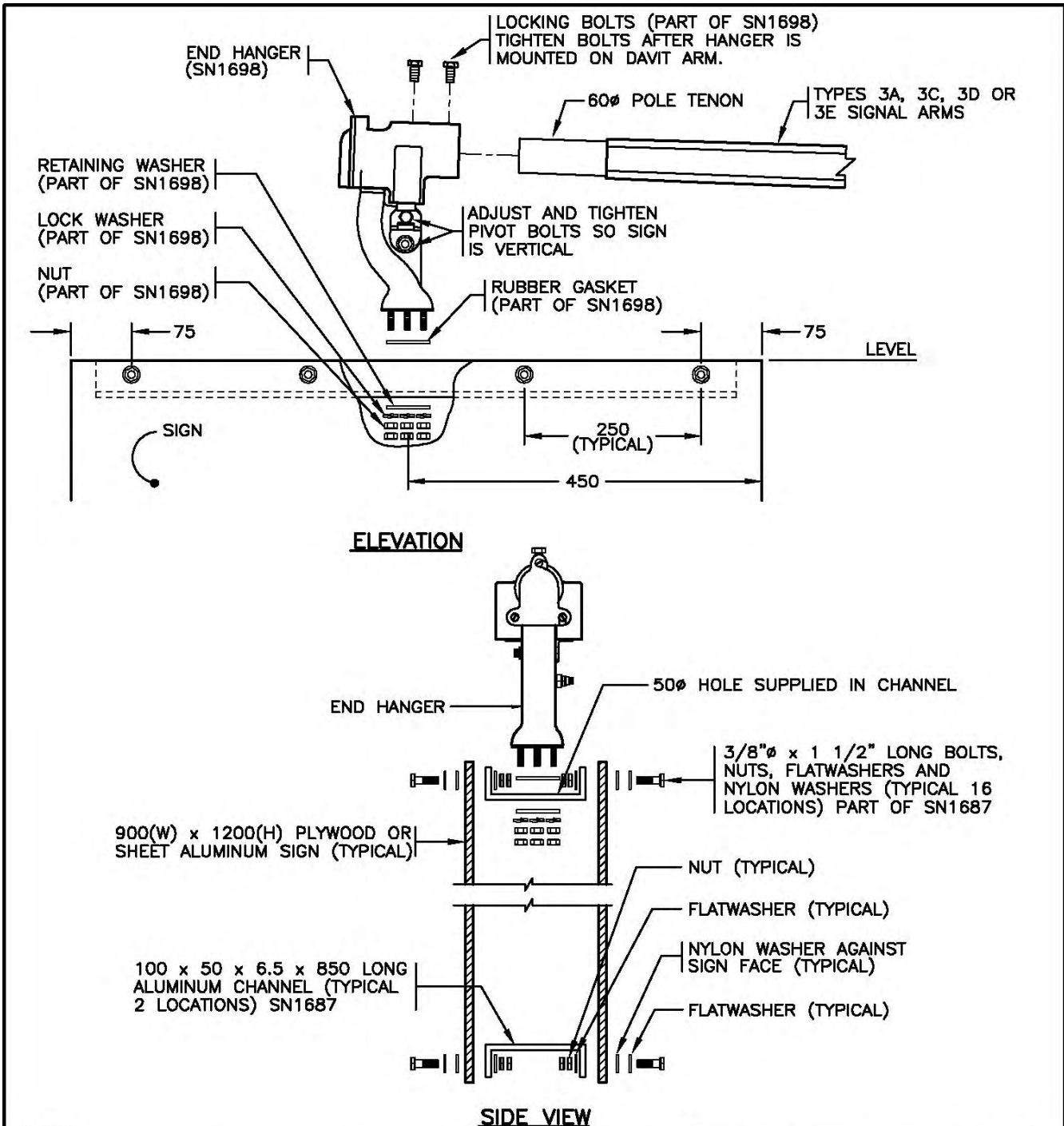

NOTES

1. SEE STANDARD SPECIFICATIONS & SPECIAL PROVISIONS FOR ADDITIONAL INFORMATION. aaaa
2. AIM SIGN AS DIRECTED BY THE MINISTRY REPRESENTATIVE.
3. 'SN' DENOTES MINISTRY STOCK NUMBER.
4. ALL DIMENSIONS ARE IN MILLIMETRES UNLESS OTHERWISE NOTED.

**MAXIMUM SIGN SIZE =
1200 X 900**



NOT TO SCALE

No.	Revision	Date	2-WAY SMALL OVERHEAD SIGN INSTALLATION DETAILS (ON TYPE 3 SIGNAL ARMS)		
F					SPECIFICATION DRAWING No. SP635-3.2.5
E					
D					
C	SHEET ALUMINUM SIGN ADDED	APR 05	Date	Approved	
B	NYLOCK NUTS REMOVED. DOUBLE NUTS ADDED	AUG 99	30/09/93	E.L. (Signature on File)	
A	GENERAL REVISION	AUG 94	Chief Highway Engineer		

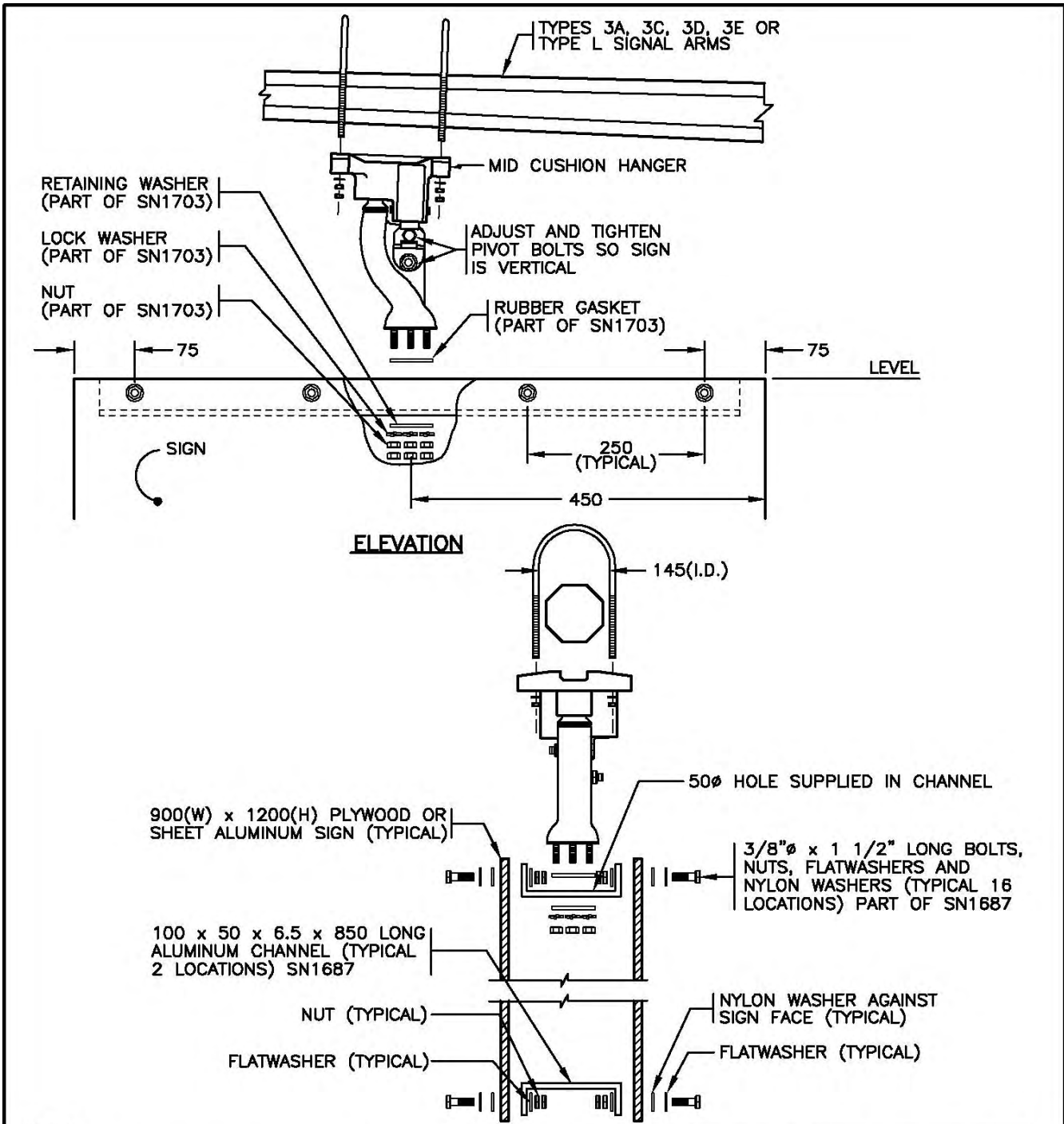

NOTES

1. SEE STANDARD SPECIFICATIONS & SPECIAL PROVISIONS FOR ADDITIONAL INFORMATION.
2. AIM SIGN AS DIRECTED BY THE MINISTRY REPRESENTATIVE.
3. 'SN' DENOTES MINISTRY STOCK NUMBER.
4. ALL DIMENSIONS ARE IN MILLIMETRES UNLESS OTHERWISE NOTED.

SIDE VIEW
aaaa

**MAXIMUM SIGN SIZE =
1200 X 900**

NOT TO SCALE



No.	Revision	Date	2-WAY SMALL OVERHEAD SIGN INSTALLATION DETAILS (FOR TYPE 3 AND L SIGNAL ARMS)		
F			Date	Approved	SPECIFICATION DRAWING No. SP635-3.2.6
E					
D					
C	SHEET ALUMINUM SIGN ADDED	APR 05	30/09/93	E.L. (Signature on File)	
B	NYLOCK NUTS REMOVED. DOUBLE NUTS ADDED	AUG 99		Chief Highway Engineer	
A	GENERAL REVISION	AUG 94			

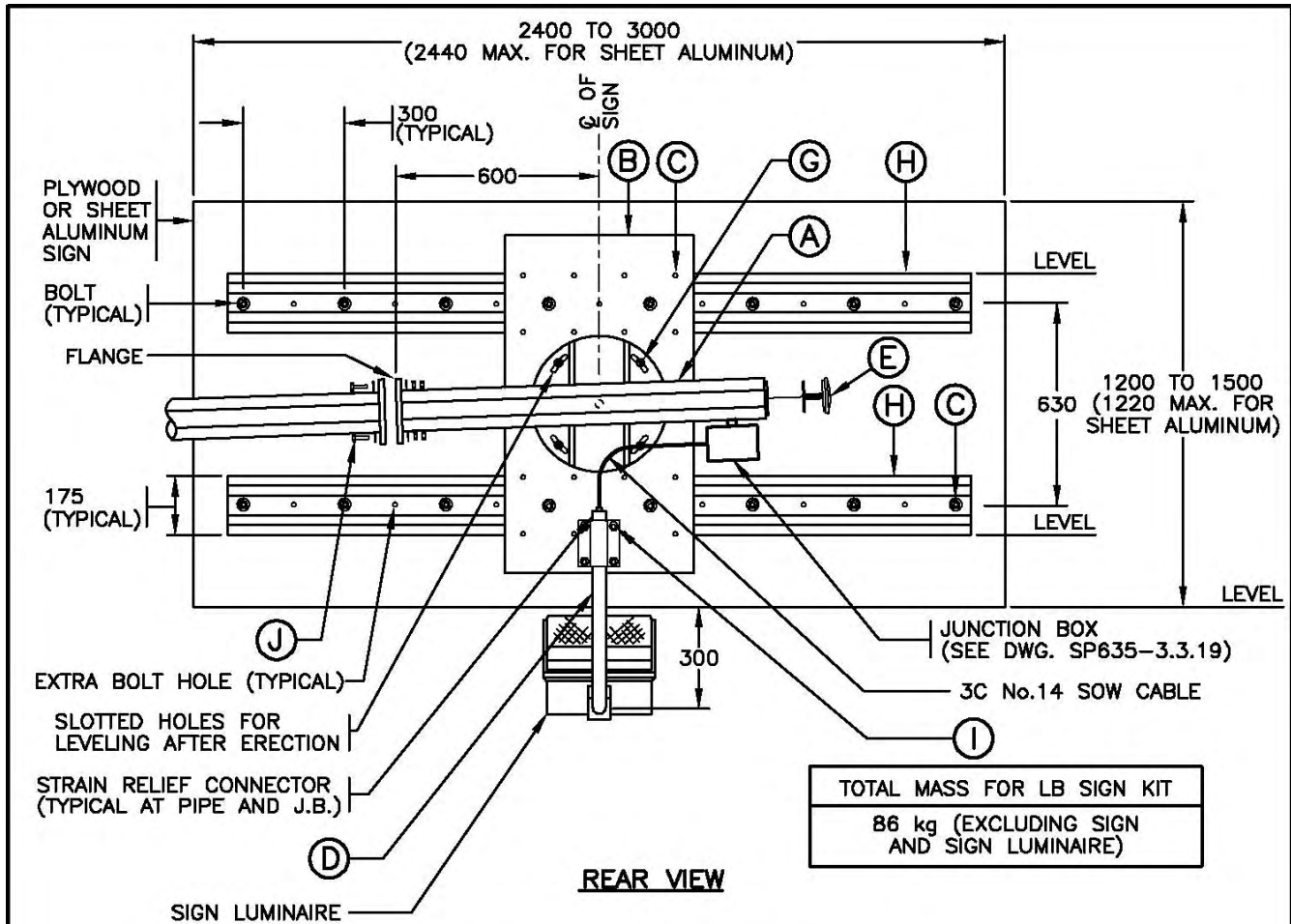

TYPE LB SIGN MOUNTING KIT (SN2096)		
ITEM	QUANTITY	DESCRIPTION
A	1	TYPE LB GALVANIZED SIGN ARM
B	1	550 x 1000 GALVANIZED SIGN SUPPORT MOUNTING PLATE
C	16	3/8"φ x 1 1/2" LONG BOLT, NUT, 2 FLATWASHERS, LOCKWASHER AND NYLON WASHER.
D	1	SIGN LUMINAIRE PIPE BRACKET
E	1	PLASTIC END CAP
F	1	PIPE MOUNTING CLAMP
G	4	1/2"φ x 1 1/4" LONG BOLT, FLATWASHER AND LOCKWASHER
H	2	2350 LONG GALVANIZED HORIZONTAL SIGN SUPPORTS
I	4	1/2"φ x 1 1/2" LONG BOLT, NUT, 2 FLATWASHERS AND LOCKWASHER
J	4	5/8"φ x 3" LONG BOLT, 2 NUTS AND 2 FLATWASHERS

SEE DRAWING SP635-3.3.2 FOR NOTES
NOT TO SCALE

SIGN LUMINAIRES SHALL BE USED ONLY WHEN SPECIFICALLY NOTED ON THE DESIGN DRAWINGS



No.	Revision	Date
F	SHEET ALUMINUM SIGN ADDED	APR 05
E	SIGN LUMINAIRE NOTE ADDED	SEPT 00
D	J.B. DRAWING REFERENCE REVISED	DEC 98
C	J.B. DRAWING REFERENCE REVISED	DEC 96
B	LUMINAIRE CHANGED & J.B. ADDED	AUG 95
A	GENERAL REVISION	AUG 94

<p>LARGE OVERHEAD GUIDE SIGN INSTALLATION DETAILS (UP TO 1500 X 3000 - PLYWOOD & 1220 X 2440 SHEET ALUMINUM)</p>		<p>SPECIFICATION DRAWING No. SP635-3.3.1</p>
<p>Date 30/09/93</p>	<p>Approved E.L. (Signature on File) Chief Highway Engineer</p>	

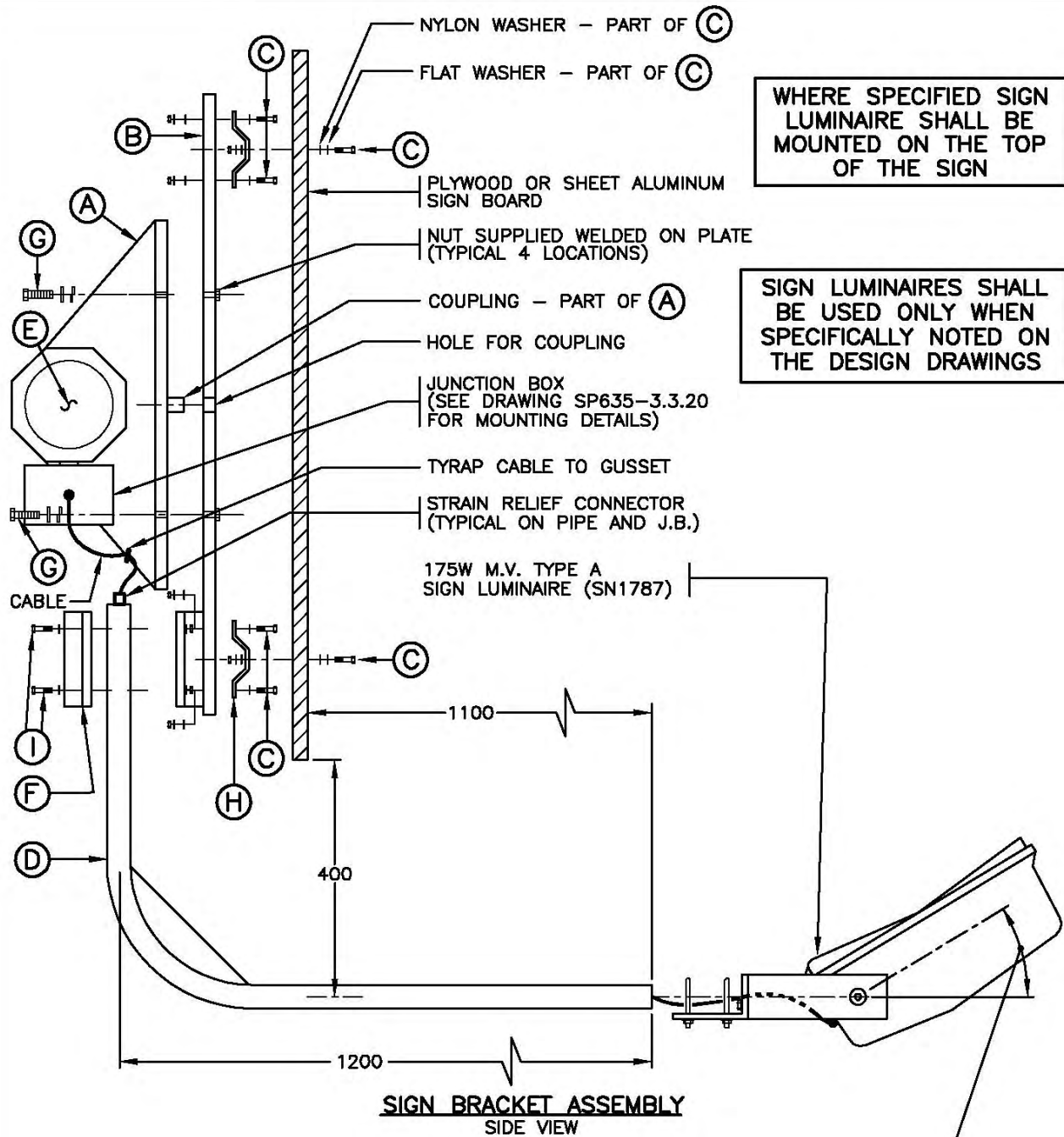

SIGN BRACKET ASSEMBLY
SIDE VIEW

NOTES

1. SEE STANDARD SPECIFICATIONS & SPECIAL PROVISIONS FOR ADDITIONAL INFORMATION.
2. 'SN' DENOTES MINISTRY STOCK NUMBER.
3. ALL DIMENSIONS ARE IN MILLIMETRES UNLESS OTHERWISE NOTED.

ANGLE TO SUIT LUMINAIRE OPTICS.
ANGLE TO BE SPECIFIED ON THE PLANS OR TO BE OBTAINED FROM THE MINISTRY REPRESENTATIVE
aaaa

SEE DRAWING SP635-3.3.1 FOR ADDITIONAL DETAILS
NOT TO SCALE



No.	Revision	Date	LARGE OVERHEAD PLYWOOD GUIDE SIGN INSTALLATION DETAILS (UP TO 1500 X 3000 - PLYWOOD & 1220 X 2440-SHEET ALUMINUM)		SPECIFICATION DRAWING No. SP635-3.3.2
F	SHEET ALUMINUM SIGN ADDED	APR 05	Date	Approved	
E	SIGN LUMINAIRE NOTE ADDED	SEPT 00	30/09/93	E.L. (Signature on File)	
D	SIGN LUMINAIRE TYPE C CHANGED TO TYPE A	NOV 98	Chief Highway Engineer		
C	SIGN LUMINAIRE & MOUNTING REVISED	DEC 96			
B	LUMINAIRE CHANGED & J.B. ADDED	AUG 95			
A	GENERAL REVISION	AUG 94			

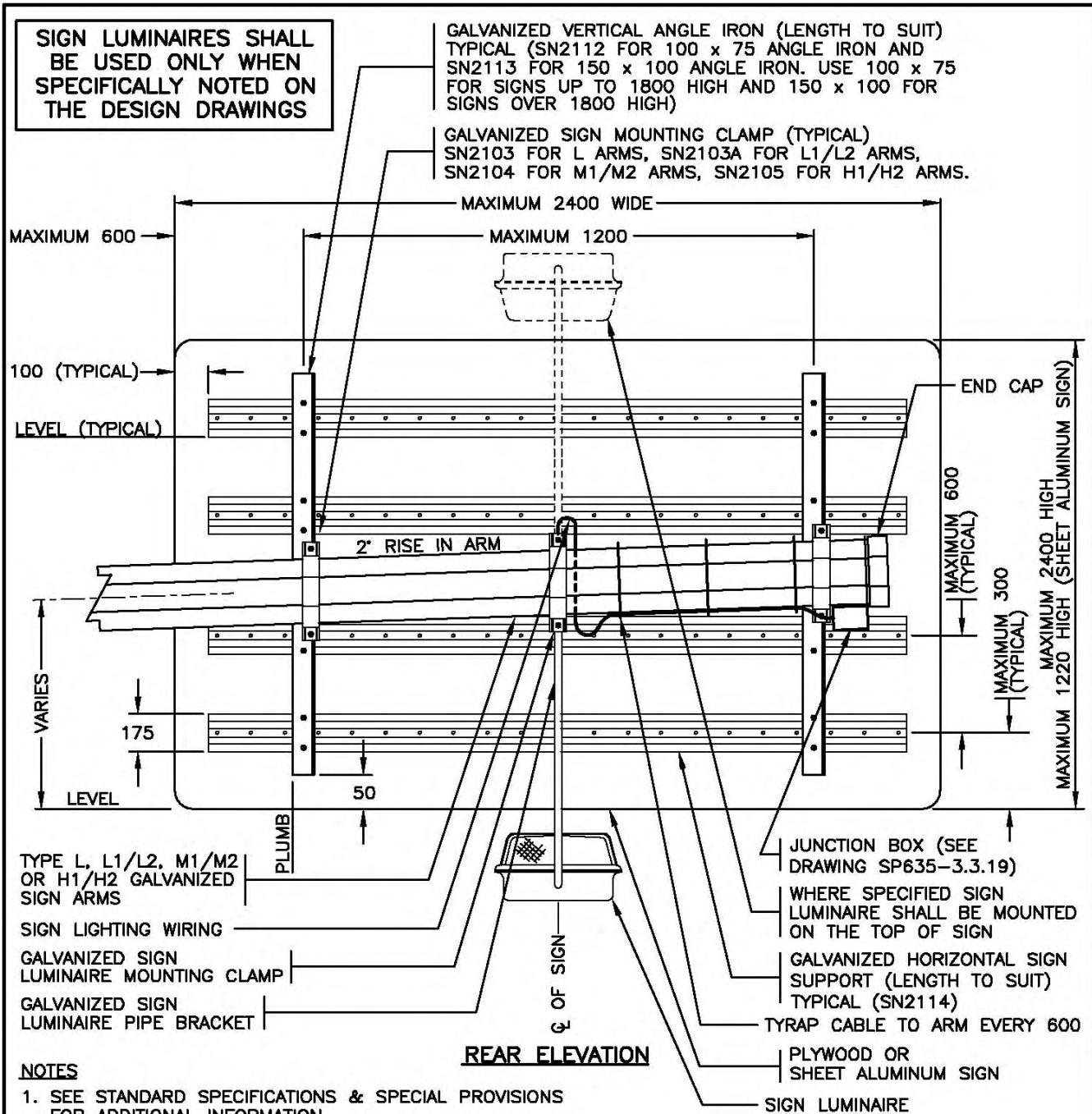

NOTES

1. SEE STANDARD SPECIFICATIONS & SPECIAL PROVISIONS FOR ADDITIONAL INFORMATION.
2. A SKETCH DETAILING THE EXACT SPACING OF VERTICAL ANGLE IRONS AND HORIZONTAL SIGN SUPPORTS WILL BE SUPPLIED WITH SIGN BRACKET ASSEMBLY.
3. NUMBER OF SIGN LUMINAIRES MAY VARY.
4. 'SN' DENOTES MINISTRY STOCK NUMBER.
5. SIGN LUMINAIRE, PIPE CLAMP AND CABLE ARE NOT REQUIRED FOR NON-ILLUMINATED SIGN.
6. ALL DIMENSIONS ARE IN MILLIMETRES UNLESS OTHERWISE NOTED.

SEE DRAWING SP635-3.3.18 FOR SIGN LIGHTING DETAILS.



NOT TO SCALE

No.	Revision	Date
G	SHEET ALUMINUM SIGN ADDED	APR 05
F	JUNCTION BOX ON SIGNAL ARM RELOCATED	NOV 01
E	SIGN LUMINAIRE NOTE ADDED	SEPT 00
D	J.B. DRAWING REFERENCE REVISED	DEC 98
C	SIGN LUMINAIRE CLAMP REVISED	DEC 96
B	L1/L2 ARMS & JUNCTION BOX ADDED	AUG 95

LARGE OVERHEAD PLYWOOD GUIDE SIGN INSTALLATION DETAILS (UP TO 2400 WIDE SIGNS)

Date: **30/09/93** Approved: **E.L. (Signature on File)**
 Chief Highway Engineer

SPECIFICATION DRAWING No. **SP635-3.3.3**

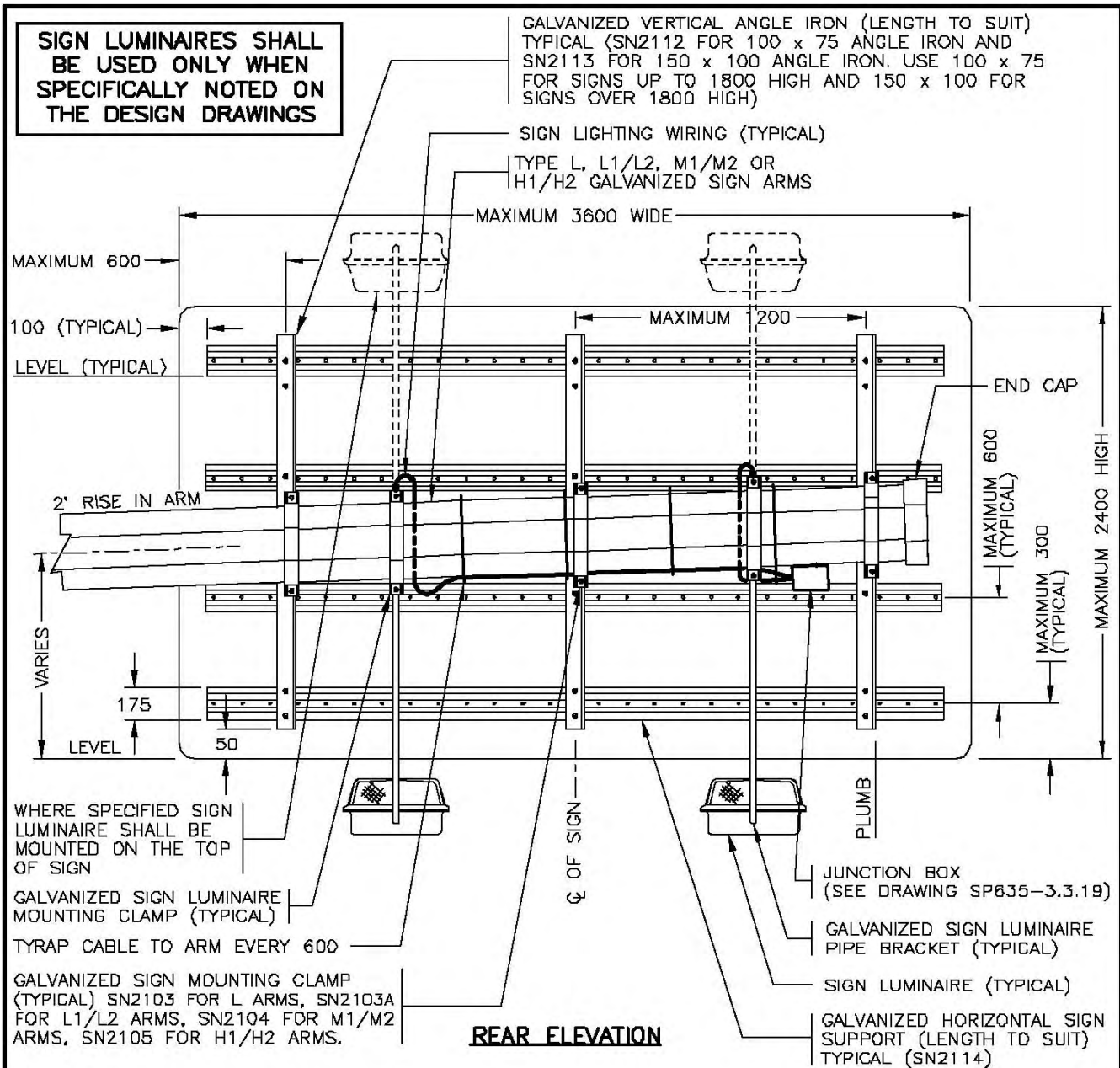

NOTES

1. SEE STANDARD SPECIFICATIONS & SPECIAL PROVISIONS FOR ADDITIONAL INFORMATION.
2. A SKETCH DETAILING THE EXACT SPACING OF VERTICAL ANGLE IRONS AND HORIZONTAL SIGN SUPPORTS WILL BE SUPPLIED WITH SIGN BRACKET ASSEMBLY.
3. NUMBER OF SIGN LUMINAIRES MAY VARY.
4. 'SN' DENOTES MINISTRY STOCK NUMBER.
5. SIGN LUMINAIRE, PIPE CLAMP AND CABLE ARE NOT REQUIRED FOR NON-ILLUMINATED SIGN.
6. ALL DIMENSIONS ARE IN MILLIMETRES UNLESS OTHERWISE NOTED.

TOTAL MASS
SIGNBOARD = 10 kg/m ²

SEE DRAWING SP635-3.3.1B FOR SIGN LIGHTING DETAILS.

NOT TO SCALE



No.	Revision	Date
F		
E	SIGN LUMINAIRE NOTE ADDED	SEPT 00
D	J.B. DRAWING REFERENCE REVISED	DEC 98
C	SIGN LUMINAIRE CLAMPS REVISED	DEC 96
B	L1/L2 ARMS & JUNCTION BOX ADDED	AUG 95
A	GENERAL REVISION	AUG 94

LARGE OVERHEAD PLYWOOD GUIDE SIGN INSTALLATION DETAILS (2500 TO 3600 WIDE SIGNS)

Date	Approved	SPECIFICATION DRAWING No.
30/09/93	E.L. (Signature on File) Chief Highway Engineer	SP635-3.3.4

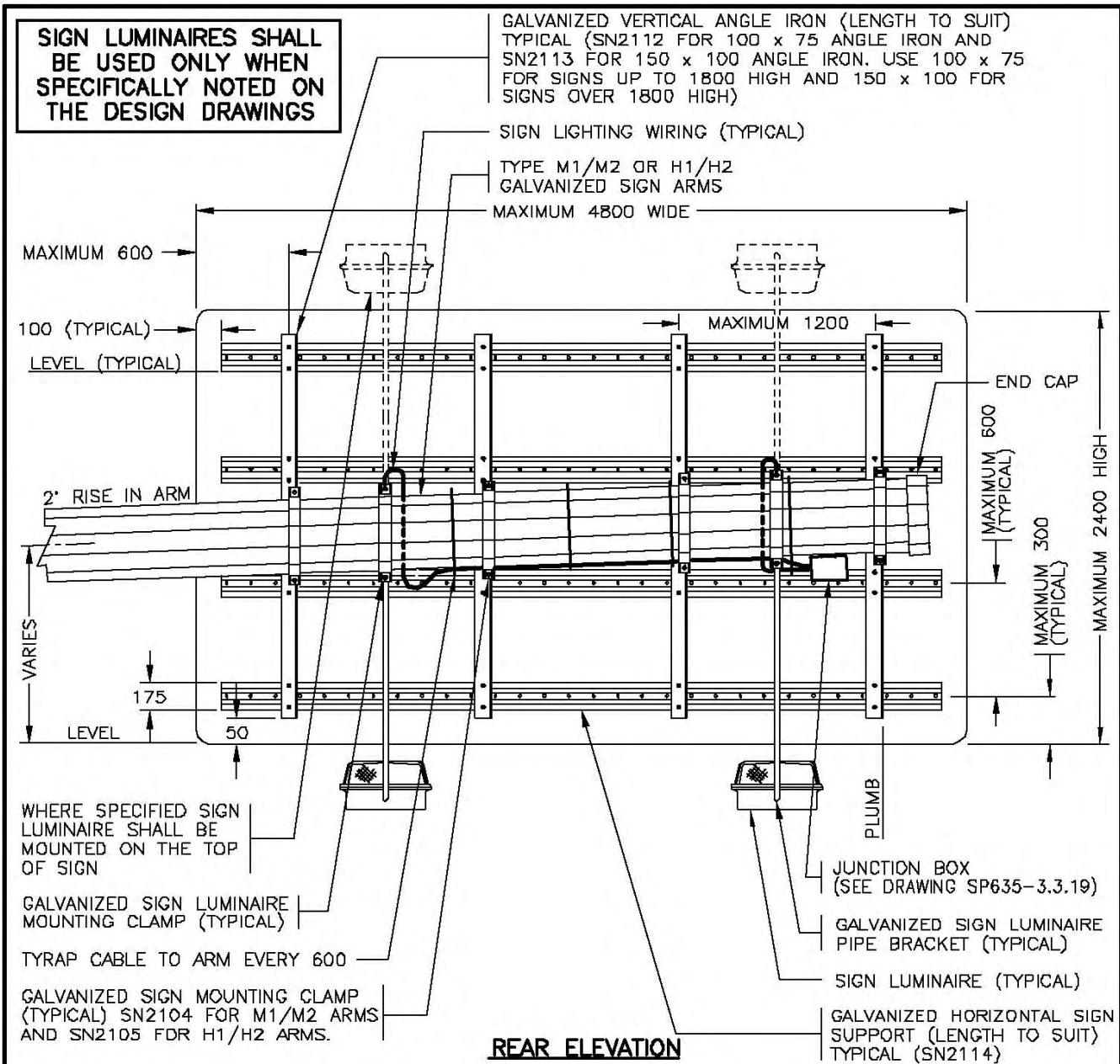

SIGN LUMINAIRES SHALL BE USED ONLY WHEN SPECIFICALLY NOTED ON THE DESIGN DRAWINGS

GALVANIZED VERTICAL ANGLE IRON (LENGTH TO SUIT) TYPICAL (SN2112 FOR 100 x 75 ANGLE IRON AND SN2113 FOR 150 x 100 ANGLE IRON. USE 100 x 75 FOR SIGNS UP TO 1800 HIGH AND 150 x 100 FOR SIGNS OVER 1800 HIGH)

SIGN LIGHTING WIRING (TYPICAL)

TYPE M1/M2 OR H1/H2 GALVANIZED SIGN ARMS

MAXIMUM 4800 WIDE

MAXIMUM 600

100 (TYPICAL)

LEVEL (TYPICAL)

MAXIMUM 1200

END CAP

600

(TYPICAL)

MAXIMUM 2400 HIGH

300

(TYPICAL)

2' RISE IN ARM

VARIES

175

LEVEL

50

PLUMB

WHERE SPECIFIED SIGN LUMINAIRE SHALL BE MOUNTED ON THE TOP OF SIGN

GALVANIZED SIGN LUMINAIRE MOUNTING CLAMP (TYPICAL)

TYRAP CABLE TO ARM EVERY 600

GALVANIZED SIGN MOUNTING CLAMP (TYPICAL) SN2104 FOR M1/M2 ARMS AND SN2105 FOR H1/H2 ARMS.

JUNCTION BOX (SEE DRAWING SP635-3.3.19)

GALVANIZED SIGN LUMINAIRE PIPE BRACKET (TYPICAL)

SIGN LUMINAIRE (TYPICAL)

GALVANIZED HORIZONTAL SIGN SUPPORT (LENGTH TO SUIT) TYPICAL (SN2114)

REAR ELEVATION

NOTES

1. SEE STANDARD SPECIFICATIONS & SPECIAL PROVISIONS FOR ADDITIONAL INFORMATION.
2. A SKETCH DETAILING THE EXACT SPACING OF VERTICAL ANGLE IRONS AND HORIZONTAL SIGN SUPPORTS WILL BE SUPPLIED WITH SIGN BRACKET ASSEMBLY.
3. NUMBER OF SIGN LUMINAIRES MAY VARY.
4. 'SN' DENOTES MINISTRY STOCK NUMBER. aaaa
5. SIGN LUMINAIRE, PIPE CLAMP AND CABLE ARE NOT REQUIRED FOR NON-ILLUMINATED SIGN.
6. ALL DIMENSIONS ARE IN MILLIMETRES UNLESS OTHERWISE NOTED.

TOTAL MASS
SIGNBOARD = 10 kg/m ²

SEE DRAWING SP635-3.3.1B FOR SIGN LIGHTING DETAILS.

NOT TO SCALE



No.	Revision	Date
F		
E	SIGN LUMINAIRE NOTE ADDED	SEPT 00
D	J.B. DRAWING REFERENCE REVISED	DEC 98
C	SIGN LUMINAIRE CLAMPS REVISED	DEC 96
B	JUNCTION BOX ADDED	AUG 95
A	GENERAL REVISION	AUG 94

LARGE OVERHEAD PLYWOOD GUIDE SIGN INSTALLATION DETAILS (3700 TO 4800 WIDE SIGNS)

Date **30/09/93** Approved **E.L. (Signature on File)**
Chief Highway Engineer

SPECIFICATION DRAWING No. **SP635-3.3.5**

GALVANIZED VERTICAL ANGLE IRONS.
 SN2112 FOR 100 x 75 ANGLE IRON
 SN2113 FOR 150 x 100 ANGLE IRON
 (USE 100 x 75 FOR SIGNS UP TO
 1800 HIGH AND 150 x 100 FOR SIGNS
 OVER 1800 HIGH).

GALVANIZED SIGN
 MOUNTING CLAMP
 SN2103 FOR L ARMS
 SN2103A FOR L1/L2 ARMS
 SN2104 FOR M1/M2 ARMS
 SN2105 FOR H1/H2 ARMS

8 SIDED FOR L, L1/L2
 AND M1/M2 ARMS
 12 SIDED FOR H1/H2 ARM

5/8"φ (LENGTH VARIES)
 BOLT, NUT, 2 FLATWASHERS
 AND LOCKWASHER.
 (SUPPLIED WITH CLAMP)

SLOTTED HOLES

GALVANIZED HORIZONTAL SIGN
 SUPPORT (SN2114)

3/8"φ x 1 1/2" LONG BOLT, NUT AND
 WASHERS (PART OF SN2114) TYPICAL

NYLON WASHER AGAINST PLYWOOD
 SIGN FACE (PART OF SN2114) TYPICAL

5/8"φ x 2 1/2" LONG BOLT, NUT,
 2 FLATWASHERS AND LOCKWASHER
 (SUPPLIED WITH CLAMP)

SLOTTED HOLES FOR MAXIMUM
 ADJUSTMENT

PLYWOOD SIGN

PLUMB

SIGN BRACKET ASSEMBLY

SIDE VIEW

NOTES

1. SEE STANDARD SPECIFICATIONS & SPECIAL PROVISIONS FOR ADDITIONAL INFORMATION.
2. ALL DIMENSIONS ARE IN MILLIMETRES UNLESS OTHERWISE NOTED.

SIGN LIGHTING NOT SHOWN
 SEE DRAWING SP635-3.3.1B FOR
 SIGN LIGHTING DETAILS.

NOT TO SCALE



No.	Revision	Date
F		
E		
D		
C	SIGN MOUNTING CLAMPS REVISED	DEC 96
B	L1/L2 ARMS ADDED & CLAMP REVISED	AUG 95
A	GENERAL REVISION	AUG 94

**LARGE OVERHEAD PLYWOOD GUIDE SIGN
 ASSEMBLY DETAILS**

Date **30/09/93** Approved **E.L. (Signature on File)**
 Chief Highway Engineer

SPECIFICATION
 DRAWING No.
SP635-3.3.6

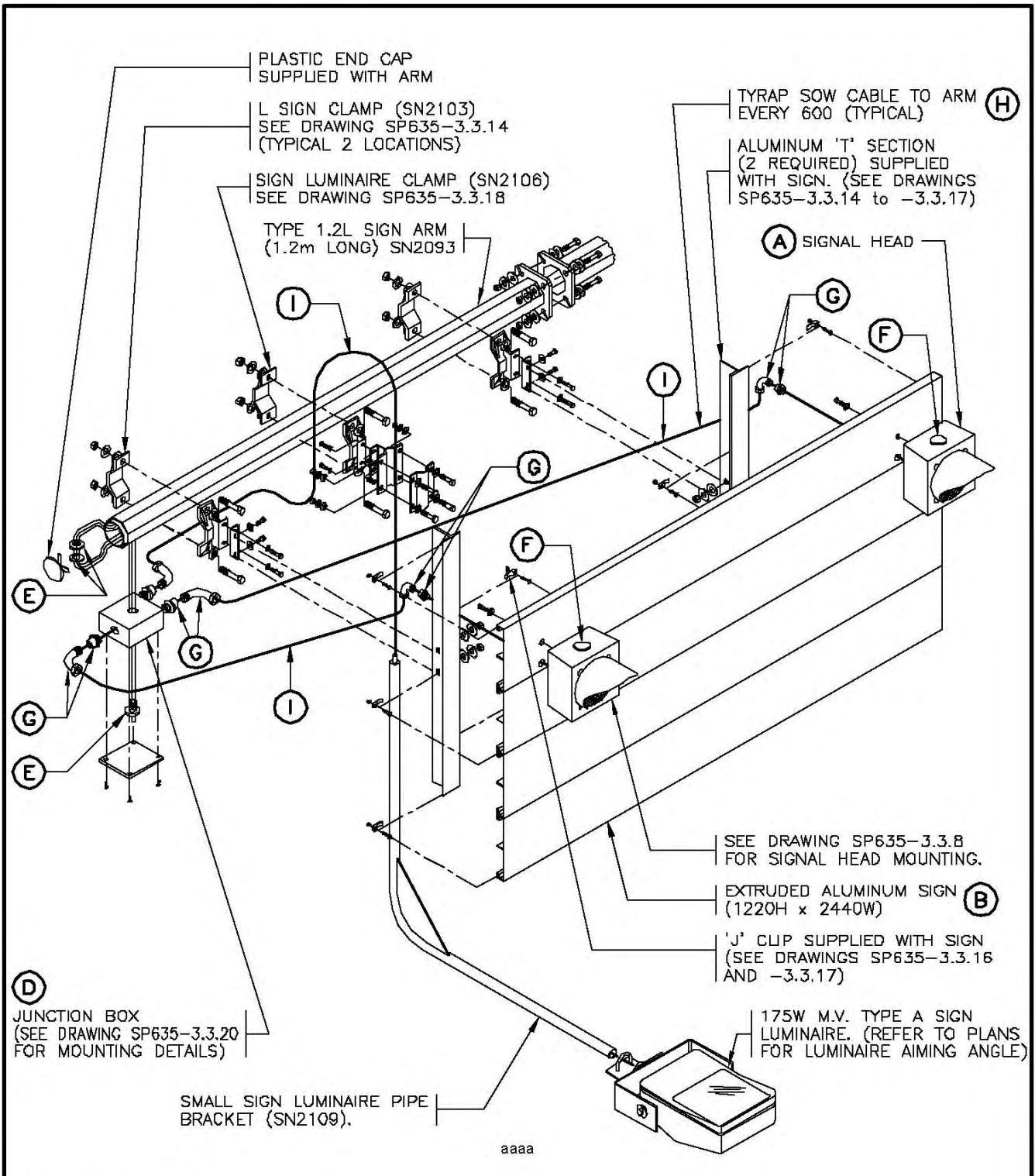

SEE DRAWING SP635-3.3.8 FOR NOTES AND ADDITIONAL DETAILS

NOT TO SCALE



No.	Revision	Date
F		
E		
D	JUNCTION BOX MOUNTING REVISED	NOV 01
C	SIGN LUMINAIRE TYPE C CHANGED TO TYPE A	NOV 98
B	SIGN ARM REDRAWN	OCT 97
A	MOUNTING CLAMPS REVISED	AUG 96

LARGE OVERHEAD EXTRUDED ALUMINUM ADVANCE WARNING SIGN ASSEMBLY DETAILS

Date: **15/11/95** Approved: **M.C. (Signature on File)**
 Chief Highway Engineer

SPECIFICATION DRAWING No. **SP635-3.3.7**

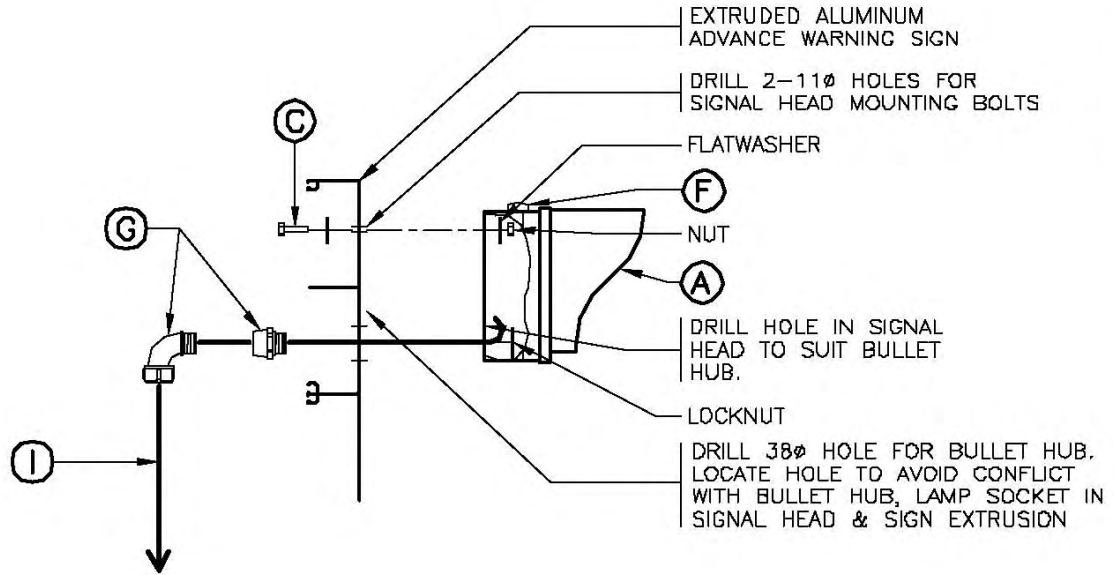

SIGNAL HEAD MOUNTING DETAIL

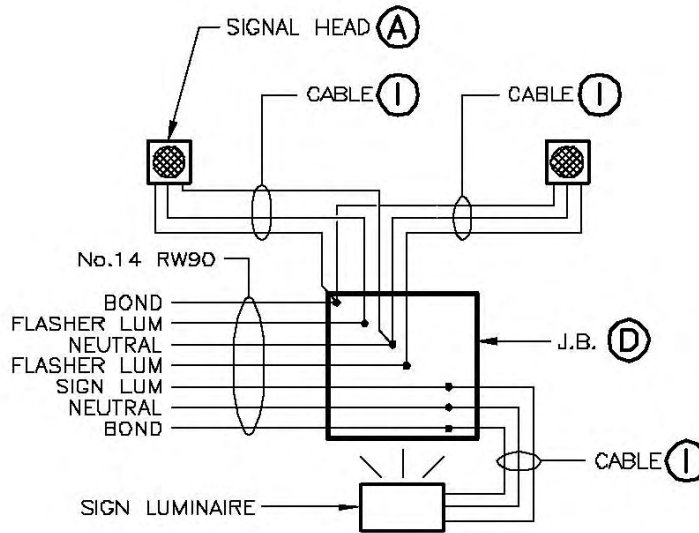

WIRING DIAGRAM

NOTES

1. SEE STANDARD SPECIFICATIONS & SPECIAL PROVISIONS FOR ADDITIONAL INFORMATION.
2. SEE DRAWINGS SP635-3.3.9 & -3.3.10 FOR PARTS LISTS. ^{aaaa}
3. 'SN' DENOTES MINISTRY STOCK NUMBER.
4. ALL DIMENSIONS ARE IN MILLIMETRES UNLESS OTHERWISE NOTED.
NOT TO SCALE



No.	Revision	Date
F		
E		
D		
C		
B	SIGN CHANGED TO ALUMINUM EXTRUDED	AUG 95
A	GENERAL REVISION	AUG 94

LARGE OVERHEAD EXTRUDED ALUMINUM ADVANCE WARNING SIGN INSTALLATION DETAILS		
Date	Approved	SPECIFICATION DRAWING No.
30/09/93	E.L. (Signature on File) Chief Highway Engineer	SP635-3.3.8

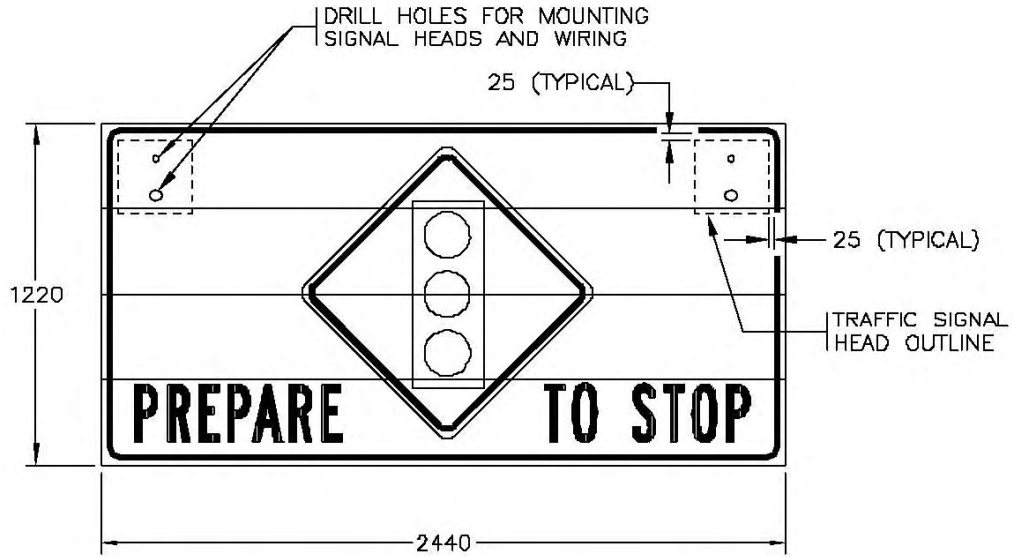

TRAFFIC SIGNAL ADVANCE WARNING SIGN

TRAFFIC SIGNAL ADVANCE WARNING SIGN KIT (SN1783D)		
ITEM	QUANTITY	DESCRIPTION
A	2	8" SIGNAL HEAD SECTION C/W YELLOW LENS, LAMP AND CDWL VISOR
B	1	TRAFFIC SIGNAL EXTRUDED ALUMINUM ADVANCE WARNING SIGN BOARD
C	2	3/8"φ x 1 1/2" LONG STAINLESS STEEL HEX HEAD BOLT, NUT, 2 FLAT WASHERS AND 1 LOCKWASHER
D	1	150 x 150 x 100 PVC J.B.
E	1	3/4" INSULATED CHASE NIPPLE, LOCKNUT AND FLAT WASHER
F	2	FINIAL
G	4	1/2" BULLET HUB AND 90° STRAIN RELIEF CONNECTOR AND LOCKNUT
H	5	LARGE TY-RAP
I	7m	3c No. 14 S.O.W. CABLE

aaaa

SEE DRAWING SP635-3.3.8 FOR NOTES

NOT TO SCALE



No.	Revision	Date	LARGE OVERHEAD EXTRUDED ALUMINUM TRAFFIC SIGNAL ADVANCE WARNING SIGN INSTALLATION DETAILS	
F			Date	Approved
E			30/09/93	E.L. (Signature on File)
D				Chief Highway Engineer
C	ITEM E REVISED	NOV 01	SPECIFICATION DRAWING No. SP635-3.3.9	
B	SIGN CHANGED TO ALUMINUM EXTRUDED	AUG 95		
A	GENERAL REVISIONS	AUG 94		

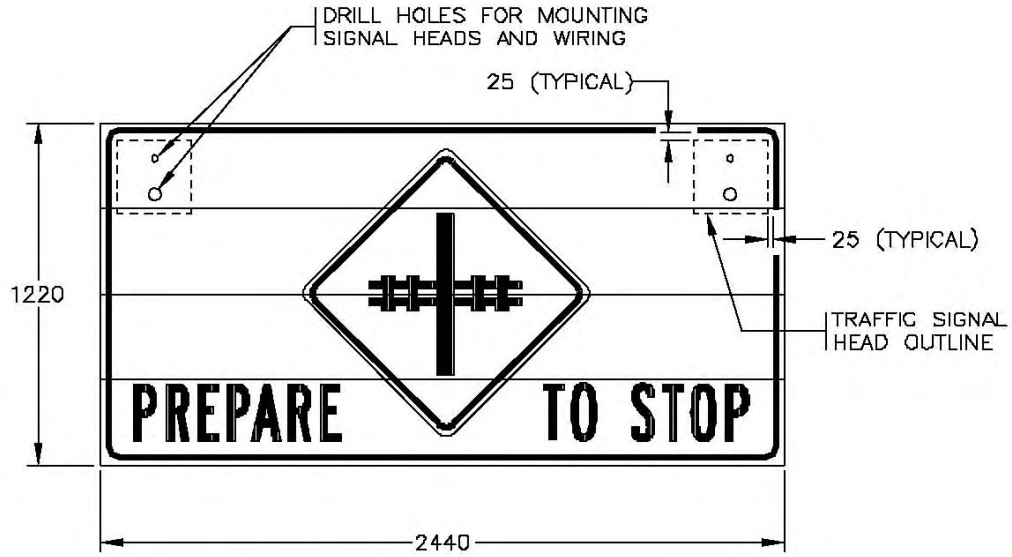

RAILWAY ADVANCE WARNING SIGN

TRAFFIC SIGNAL ADVANCE WARNING SIGN KIT (SN1783E)		
ITEM	QUANTITY	DESCRIPTION
A	2	8" SIGNAL HEAD SECTION C/W YELLOW LENS, LAMP AND COWL VISOR
B	1	EXTRUDED ALUMINUM RAILWAY ADVANCE WARNING SIGN BOARD
C	2	3/8"Ø x 1 1/2" LONG STAINLESS STEEL HEX HEAD BOLT, NUT, 2 FLAT WASHERS AND 1 LOCKWASHER
D	1	150 x 150 x 100 PVC J.B.
E	1	3/4" INSULATED CHASE NIPPLE, 2 LOCKNUTS AND 2 FLAT WASHERS
F	2	FINIAL
G	4	1/2" BULLET HUB AND 90° STRAIN RELIEF CONNECTOR AND LOCKNUT
H	5	LARGE TY-RAP
I	7m	3c No. 14 S.D.W. CABLE

aaaa

SEE DRAWING SP635-3.3.8 FOR NOTES

NOT TO SCALE



No.	Revision	Date	LARGE OVERHEAD EXTRUDED ALUMINUM RAILWAY ADVANCE WARNING SIGN INSTALLATION DETAILS	
F			Date	Approved
E			18/11/94	E.L. (Signature on File)
D			SPECIFICATION DRAWING No. SP635-3.3.10	
C			Chief Highway Engineer	
B	SIGN CHANGED TO ALUMINUM EXTRUDED	AUG 95		
A	GENERAL REVISIONS	AUG 94		

SIGN LUMINAIRES SHALL BE USED ONLY WHEN SPECIFICALLY NOTED ON THE DESIGN DRAWINGS

ALUMINUM 'T' SECTION (SUPPLIED WITH SIGN) SEE DRAWINGS SP635-3.3.14 to -3.3.17

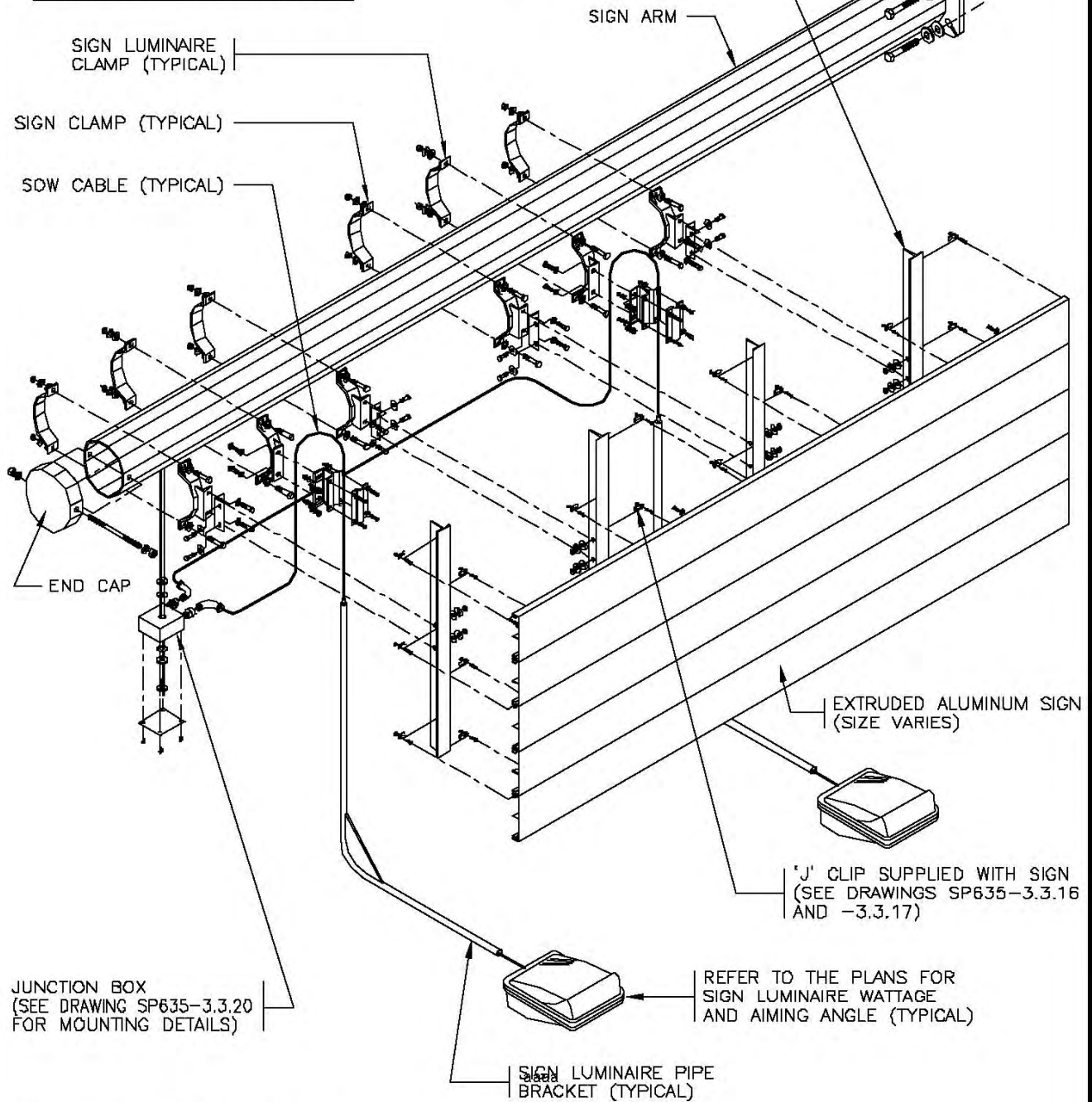

JUNCTION BOX (SEE DRAWING SP635-3.3.20 FOR MOUNTING DETAILS)

SEE DRAWING SP635-3.3.12 FOR NOTES AND ADDITIONAL DETAILS

NOT TO SCALE



No.	Revision	Date
F		
E		
D		
C	SIGN LUMINAIRE NOTE ADDED	SEPT 00
B	SIGN LUMINAIRE TYPE B NOTE DELETED	NOV 98
A	MOUNTING CLAMPS REVISED	AUG 96

LARGE OVERHEAD EXTRUDED ALUMINUM GUIDE SIGN ASSEMBLY DETAILS		
Date	Approved	SPECIFICATION DRAWING No.
15/11/95	M.C. (Signature on File) Chief Highway Engineer	SP635-3.3.11

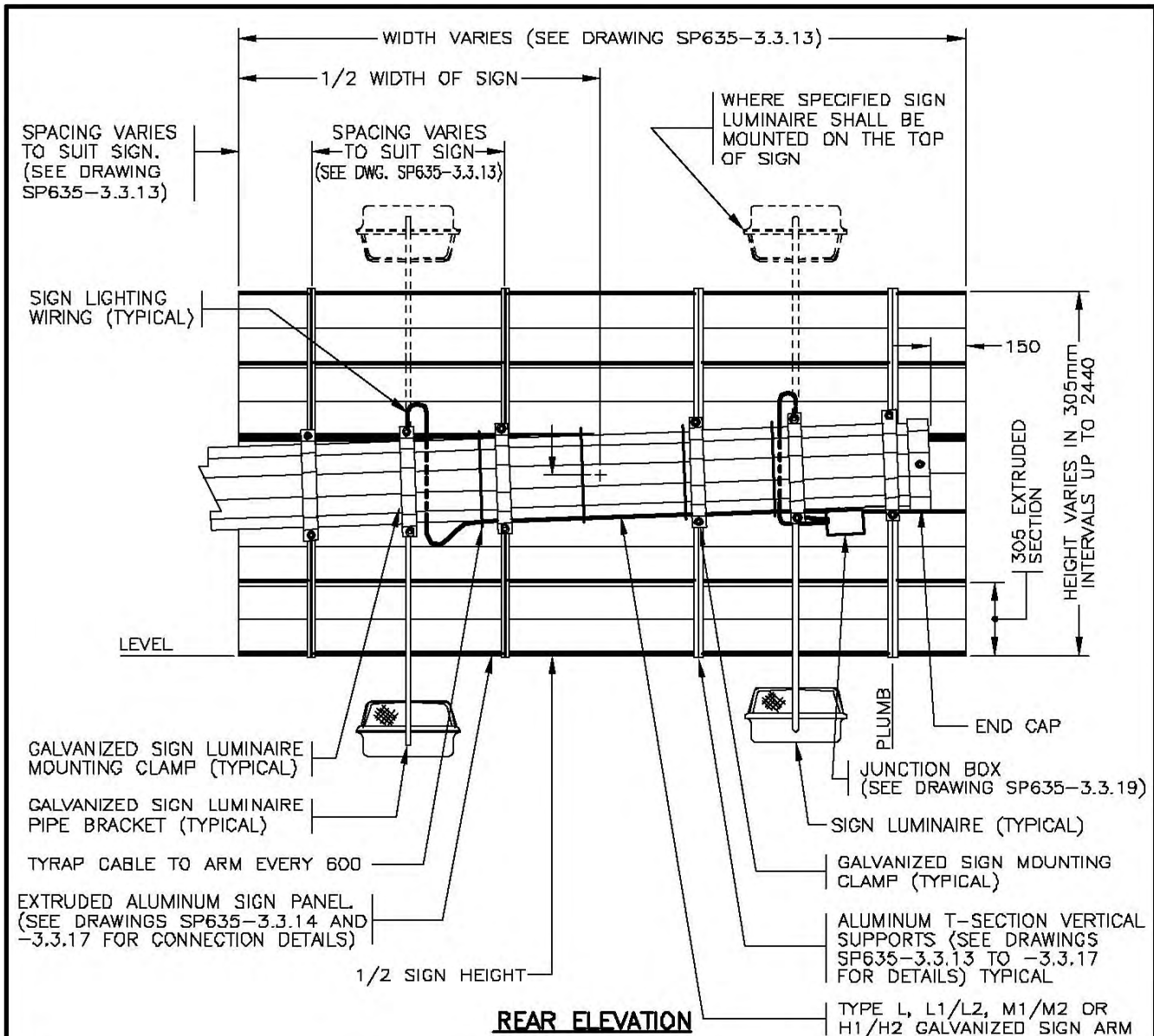

TOTAL MASS
EACH EXTRUDED ALUMINUM SIGN SECTION = 4 kg/m

NOTES

1. SEE STANDARD SPECIFICATIONS & SPECIAL PROVISIONS FOR ADDITIONAL INFORMATION.
2. NUMBER OF SIGN LUMINAIRES MAY VARY.
3. 'SN' DENOTES MINISTRY STOCK NUMBER.
4. FUSE SIGN LUMINAIRES IN POLE HANDHOLE.
5. SIGN LUMINAIRE, MOUNTING PIPE, CLAMP AND CABLE IS NOT REQUIRED FOR NON-ILLUMINATED SIGN.
6. ALL DIMENSIONS ARE IN MILLIMETRES UNLESS OTHERWISE NOTED.

SIGN LUMINAIRES SHALL BE USED ONLY WHEN SPECIFICALLY NOTED ON THE DESIGN DRAWINGS



SEE DRAWING SP635-3.3.1B FOR SIGN LIGHTING DETAILS.

NOT TO SCALE

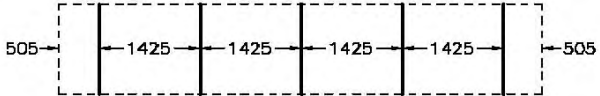
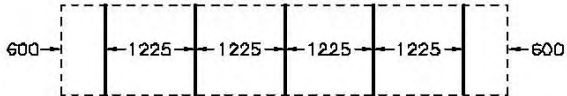
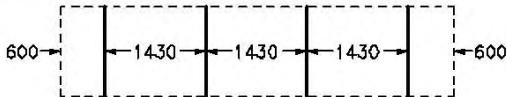

No.	Revision	Date
F		
E		
D	SIGN LUMINAIRE NOTE ADDED	SEPT 00
C	J.B. DRAWING REFERENCE REVISED	DEC 98
B	SIGN LUMINAIRE CLAMPS REVISED	DEC 96
A	L1/L2 ARMS & JUNCTION BOX ADDED	AUG 95

LARGE OVERHEAD EXTRUDED ALUMINUM GUIDE SIGN INSTALLATION DETAILS		
Date	Approved	SPECIFICATION DRAWING No.
21/11/94	E.L. (Signature on File) Chief Highway Engineer	SP635-3.3.12

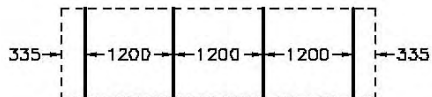
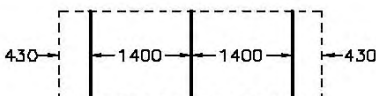
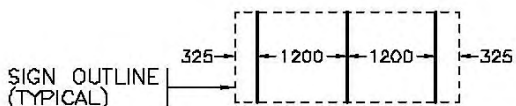
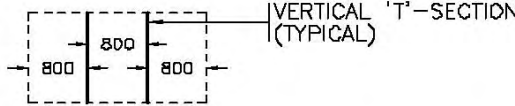
TYPICAL SIGN WIDTH	SPACING OF VERTICAL T-SECTIONS	NUMBER OF VERTICALS
7320mm		6
6710mm		5
6100mm		5
5490mm		4
4880mm		4
4270mm		4
3660mm		3
3050mm		3
2440mm		2

aaaa

SEE DRAWING SP635-3.3.12 FOR NOTES AND ADDITIONAL DETAILS



NOT TO SCALE

No.	Revision	Date	<p>LARGE OVERHEAD EXTRUDED ALUMINUM GUIDE SIGN INSTALLATION DETAILS</p>		<p>SPECIFICATION DRAWING No. SP635-3.3.13</p>
F					
E			Date	Approved	
D			18/11/94	E.L. (Signature on File)	
C				Chief Highway Engineer	
B	T-SECTION SPACING FOR 2440 WIDE SIGN REVISED	AUG 96			
A	SIGN WIDTHS & T-SECTION SPACING REVISED	AUG 95			

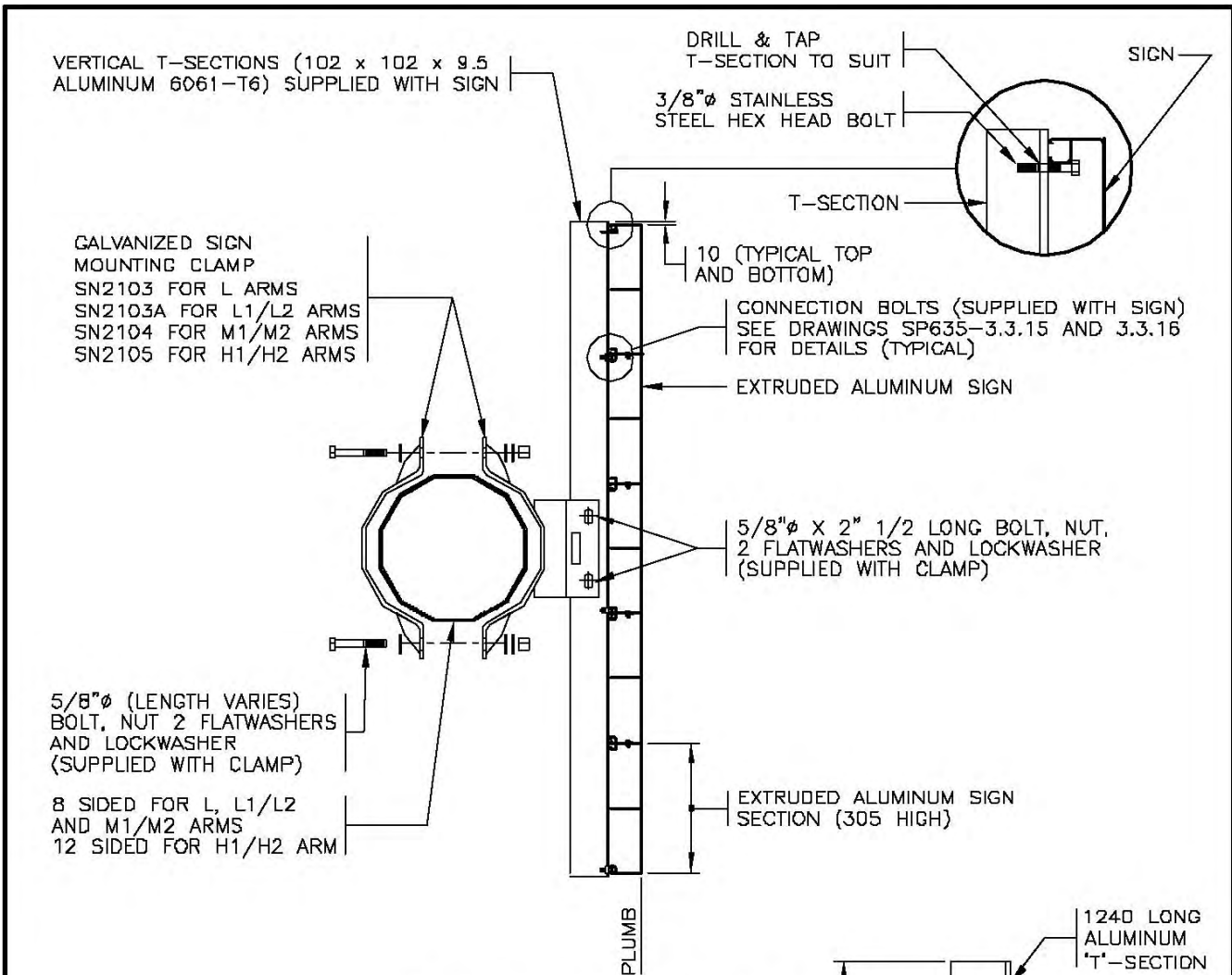

SIGN BRACKET ASSEMBLY

SIDE VIEW

FIELD DRILL 14Ø HOLE FOR LOCKING BOLT AFTER T-SECTION IS INSTALLED ON CLAMP

SEE DRAWING SP635-3.3.12 FOR NOTES AND ADDITIONAL DETAILS.

SIGN LIGHTING NOT SHOWN. SEE DRAWING SP635-3.3.18 FOR SIGN LIGHTING DETAILS.

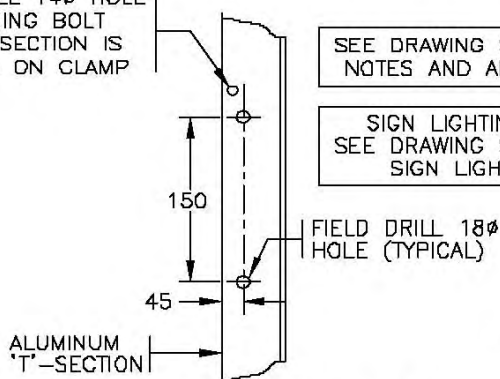

'T'-SECTION HOLE DETAIL

(FOR L1/L2, M1/M2 & H1/H2 SIGN ARMS)

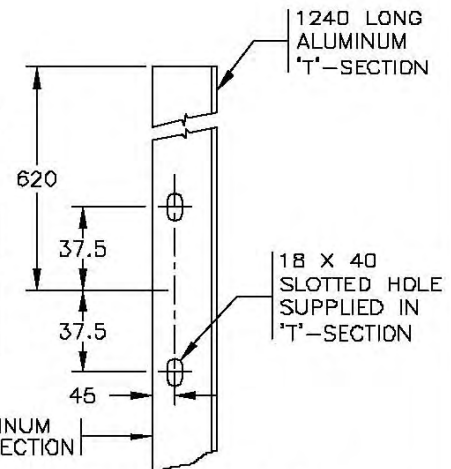

'T'-SECTION SLOT DETAIL

(FOR 1.2m(H) X 2.4m(W) SIGN ON L SIGN ARM)

aaaa



NOT TO SCALE

No.	Revision	Date
F		
E		
D		
C	'T'-SECTION SLOT DETAIL ADDED	NOV 01
B	MOUNTING CLAMPS REV'D & SAFETY BOLT ADDED	AUG 96
A	L1/L2 ARMS ADDED & T-SECTION DETAILS REVISED	AUG 95

LARGE OVERHEAD EXTRUDED ALUMINUM GUIDE SIGN ASSEMBLY DETAILS

Date Approved
18/11/94 E.L. (Signature on File)
Chief Highway Engineer

SPECIFICATION DRAWING No.
SP635-3.3.14

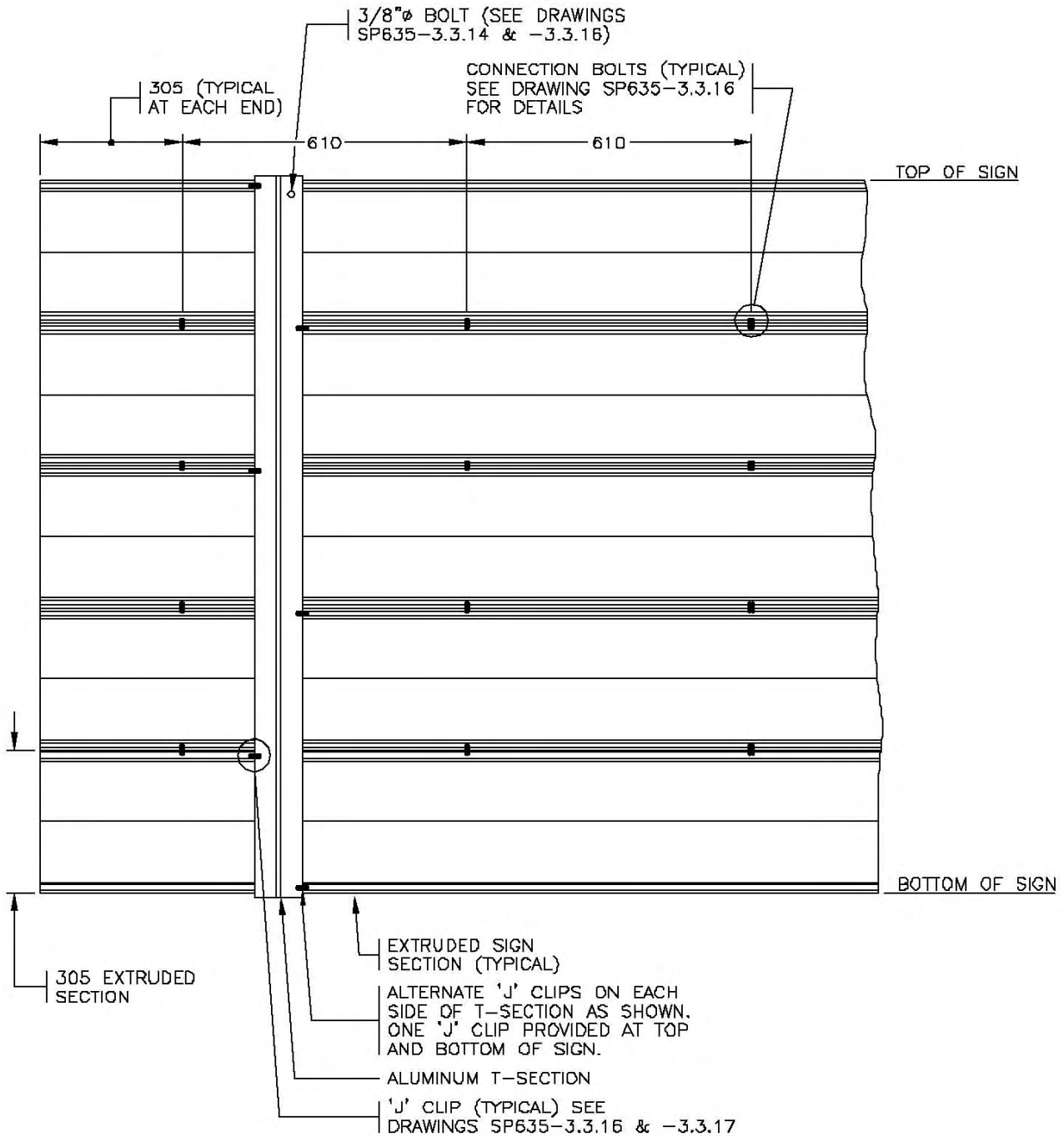

REAR VIEW OF SIGN

SEE DRAWING SP635-3.3.12 FOR NOTES AND ADDITIONAL DETAILS.



NOT TO SCALE

No.	Revision	Date
F		
E		
D		
C		
B	SAFETY BOLT ADDED	AUG 96
A	END HOLE SPACING REVISED	AUG 95

LARGE OVERHEAD EXTRUDED ALUMINUM GUIDE SIGN ASSEMBLY DETAILS		
Date	Approved	SPECIFICATION DRAWING No.
18/11/94	E.L. (Signature on File) Chief Highway Engineer	SP635-3.3.15

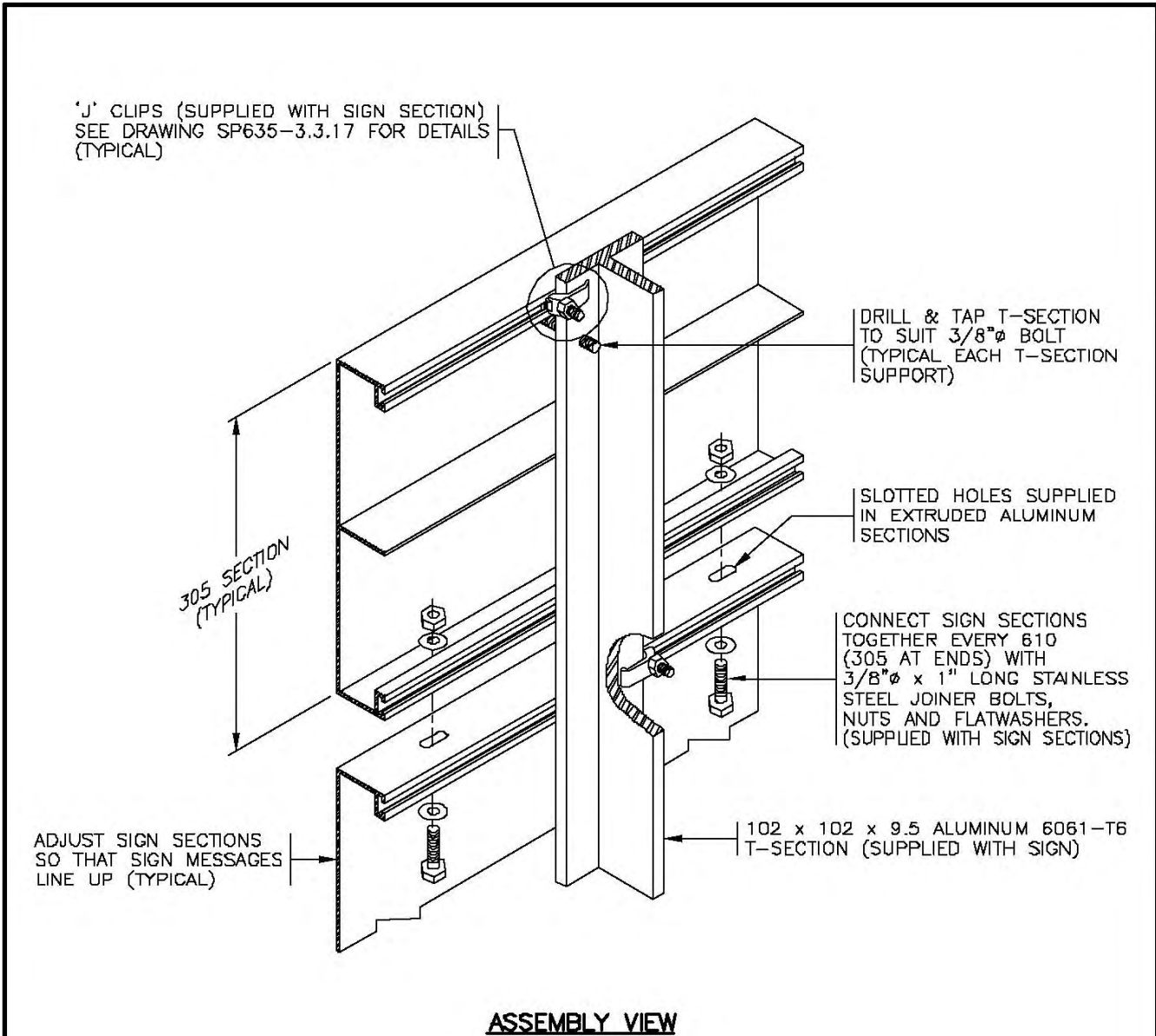

**TORQUE JOINER BOLTS AND
'J' CLIPS TO 19 ft. lbs.**

aaaa

SEE DRAWING SP635-3.3.12 FOR
NOTES AND ADDITIONAL DETAILS.



NOT TO SCALE

No.	Revision	Date
F		
E		
D		
C		
B	SAFETY BOLT ADDED	AUG 96
A	END HOLE SPACING REVISED	AUG 95

**LARGE OVERHEAD EXTRUDED ALUMINUM
GUIDE SIGN ASSEMBLY DETAILS**

Date: **18/11/94** Approved: **E.L. (Signature on File)**
Chief Highway Engineer

SPECIFICATION
DRAWING No.
SP635-3.3.16

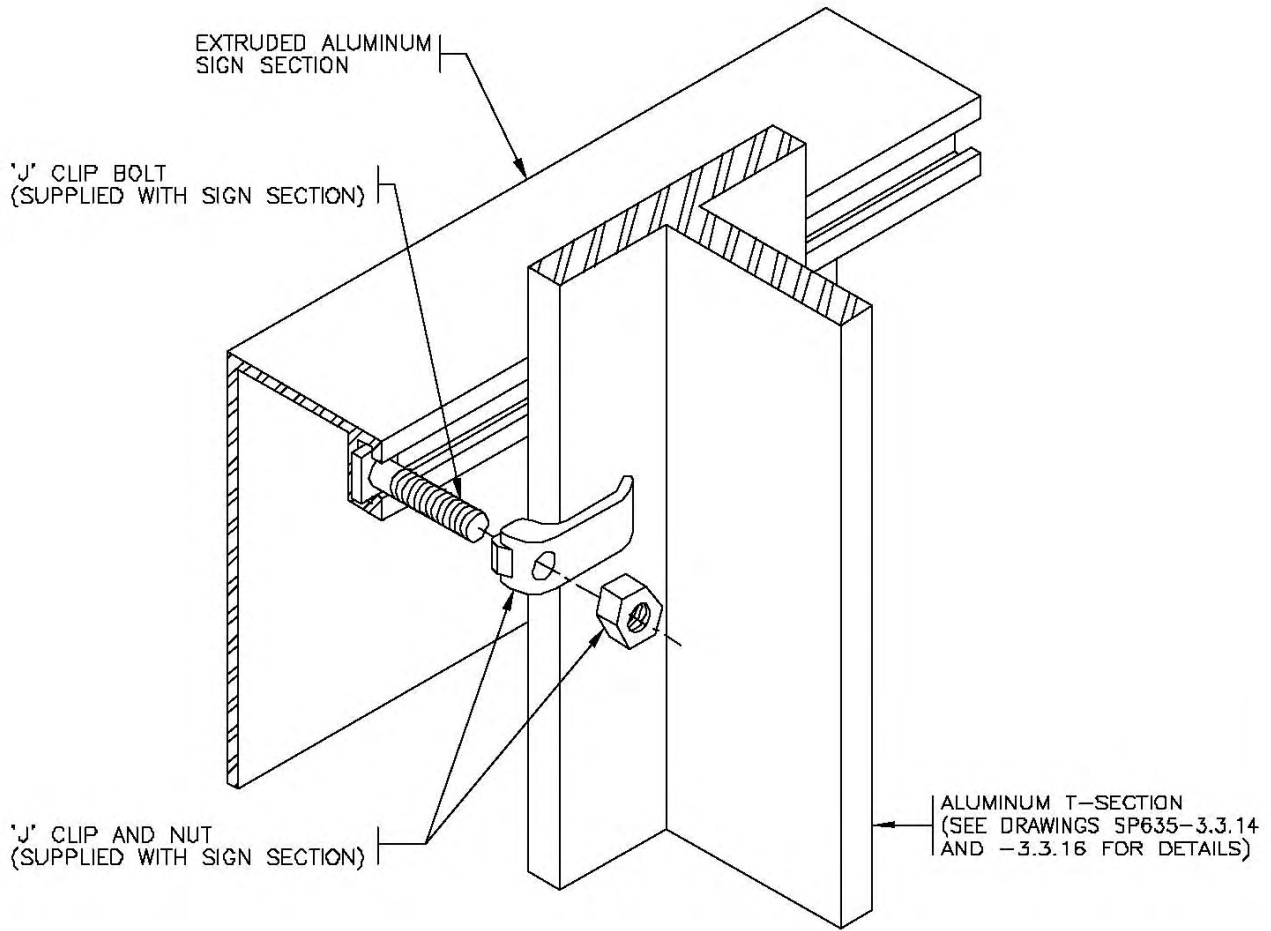

ASSEMBLY VIEW

TORQUE JOINER BOLTS AND 'J' CLIPS TO 19 ft. lbs.

aaaa

SEE DRAWING SP635-3.3.12 FOR NOTES AND ADDITIONAL DETAILS.



NOT TO SCALE

No.	Revision	Date
F		
E		
D		
C		
B		
A	DRAWING NUMBER REVISED	AUG 95

LARGE OVERHEAD EXTRUDED ALUMINUM GUIDE SIGN ASSEMBLY DETAILS

Date **18/11/94** Approved **E.L. (Signature on File)**
 Chief Highway Engineer

SPECIFICATION DRAWING No. **SP635-3.3.17**

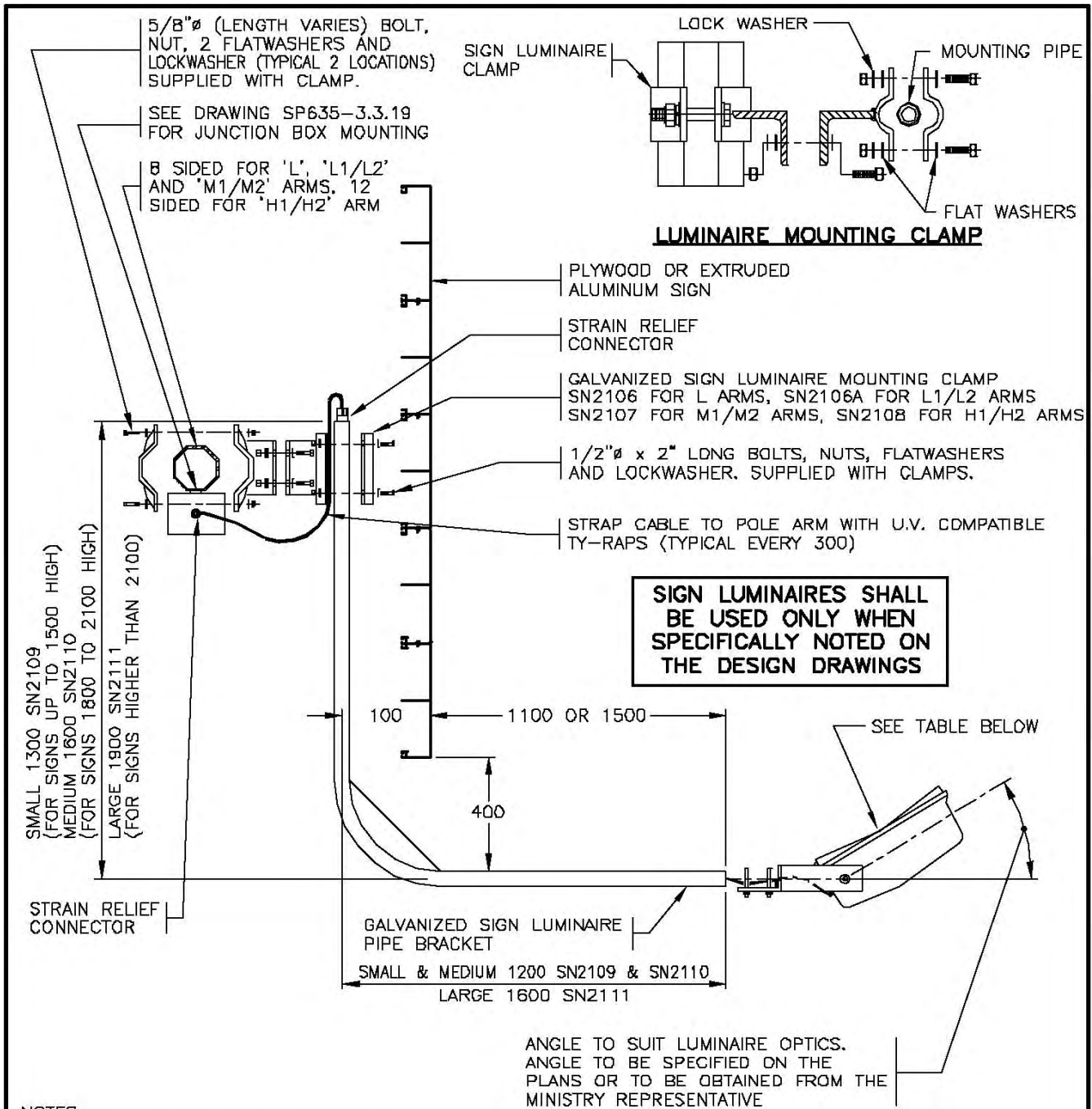

NOTES

1. SEE STANDARD SPECIFICATIONS & SPECIAL PROVISIONS FOR ADDITIONAL INFORMATION.
2. ALL DIMENSIONS ARE IN MILLIMETRES UNLESS OTHERWISE NOTED.
3. USE TYPE A 175W MV SIGN LUMINAIRES FOR ALL SIGNS UP TO 1.8m HIGH BY 3.0m WIDE. REFER TO THE PLANS FOR SIGN LUMINAIRE TYPE AND AIMING ANGLES FOR SIGNS LARGER THAN 1.8m HIGH BY 3.0m WIDE.

LUMINAIRE TYPE AND WATTAGE	STOCK NUMBER	LAMP	SIGN LUMINAIRE ARM LENGTH
TYPE A 175W MV	SN1787	175W MV COATED LAMP	1200
TYPE A 250W MV	SN1783A	250W MV COATED LAMP	1600
TYPE B 250W MV	SN1783	250W MV COATED LAMP	1600

SIGN LIGHTING
SIDE VIEW



NOT TO SCALE

No.	Revision	Date
F	JUNCTION BOX MOUNTING REVISED	NOV 01
E	SIGN LUMINAIRE NOTE ADDED	SEPT 00
D	SIGN LUMINAIRE MOUNTING DIMENSIONS CHANGED	NOV 98
C	SIGN LUMINAIRE & MOUNTING REVISED	DEC 96
B	TYPE C LUMINAIRE & J.B. ADDED	AUG 95
A	GENERAL REVISION	AUG 94

LARGE OVERHEAD GUIDE SIGN LUMINAIRE INSTALLATION DETAILS		
Date	Approved	SPECIFICATION DRAWING No.
30/09/93	E.L. (Signature on File) Chief Highway Engineer	SP635-3.3.18

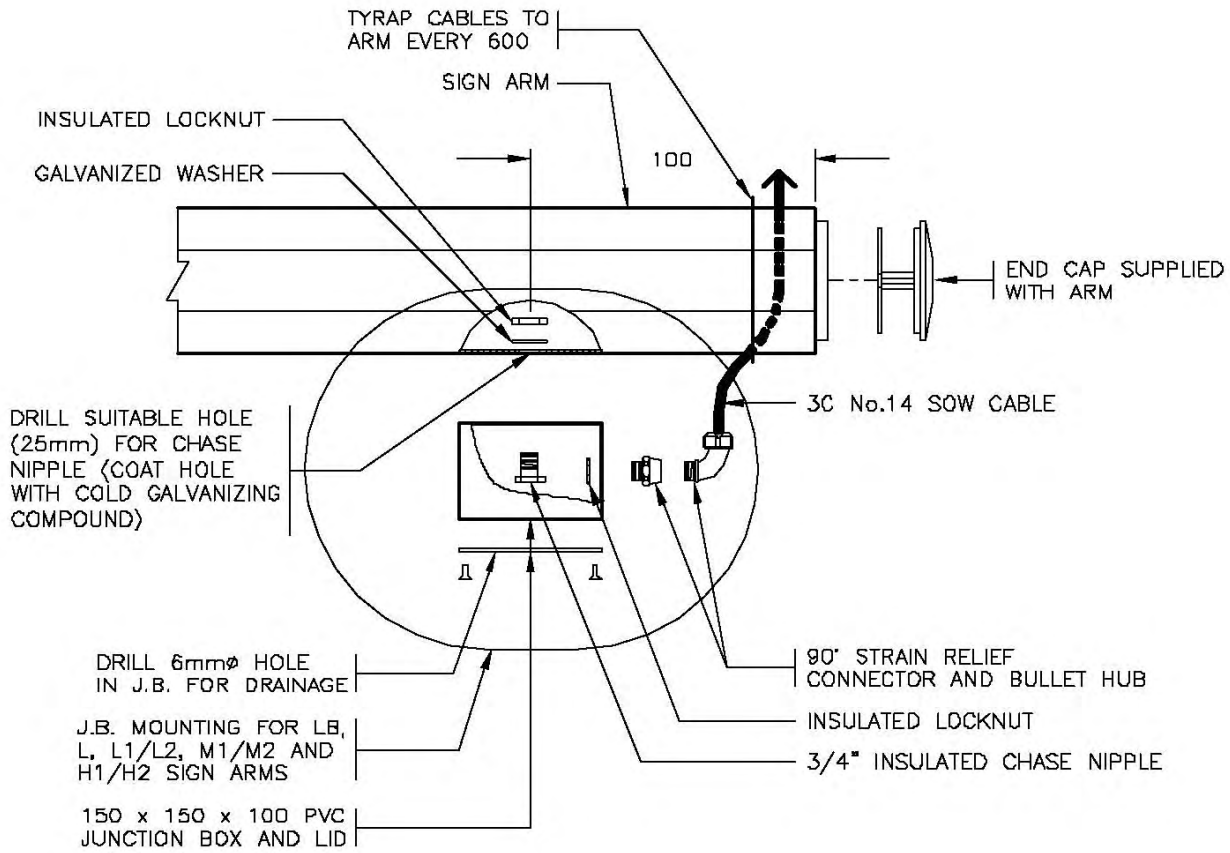

J.B. MOUNTING DETAIL

NOTES

1. SEE STANDARD SPECIFICATIONS & SPECIAL PROVISIONS FOR ADDITIONAL INFORMATION.
2. 'SN' DENOTES MINISTRY STOCK NUMBER.
3. ALL DIMENSIONS ARE IN MILLIMETRES UNLESS OTHERWISE NOTED.

aaaa

NOT TO SCALE



No.	Revision	Date	JUNCTION BOX INSTALLATION DETAILS ON SIGN ARMS		SPECIFICATION DRAWING No.
F			Date	Approved	SP635-3.3.19
E			15/11/95	M.C. (Signature on File)	
D			Chief Highway Engineer		
C					
B	MOUNTING REVISED	NOV 01			
A	DRAWING NUMBER REVISED	DEC 98			

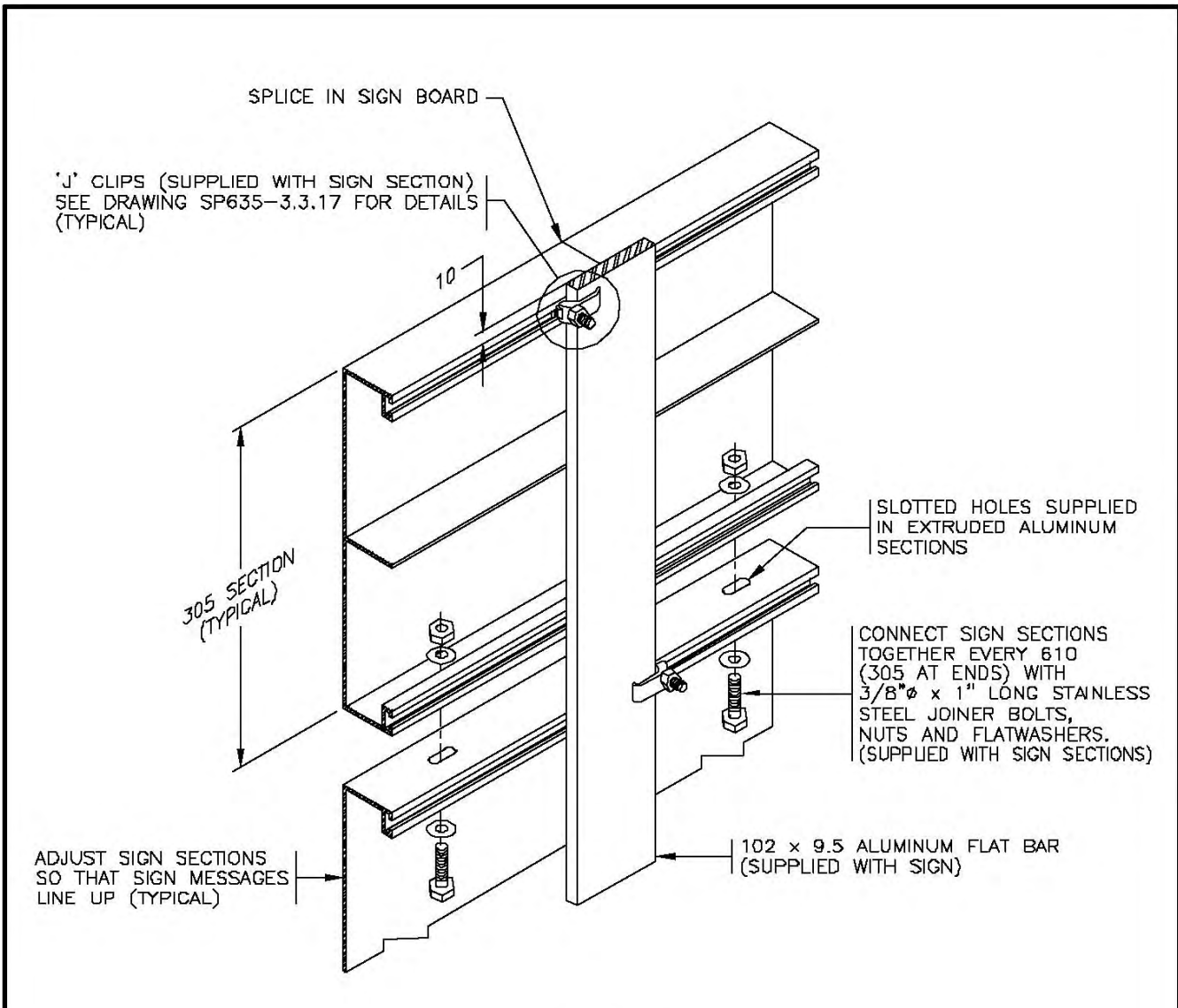

ASSEMBLY VIEW

TORQUE JOINER BOLTS AND 'J' CLIPS TO 19 ft. lbs.

aaaa

SEE DRAWING SP635-3.3.12 FOR NOTES AND ADDITIONAL DETAILS.



NOT TO SCALE

No.	Revision	Date
F		
E		
D		
C		
B		
A	DRAWING NUMBER REVISED	DEC 98

LARGE OVERHEAD EXTRUDED ALUMINUM GUIDE SIGN FLAT BAR AT SPLICE DETAILS

Date	Approved
_____ Chief Highway Engineer	
SPECIFICATION DRAWING No. SP635-3.3.20	

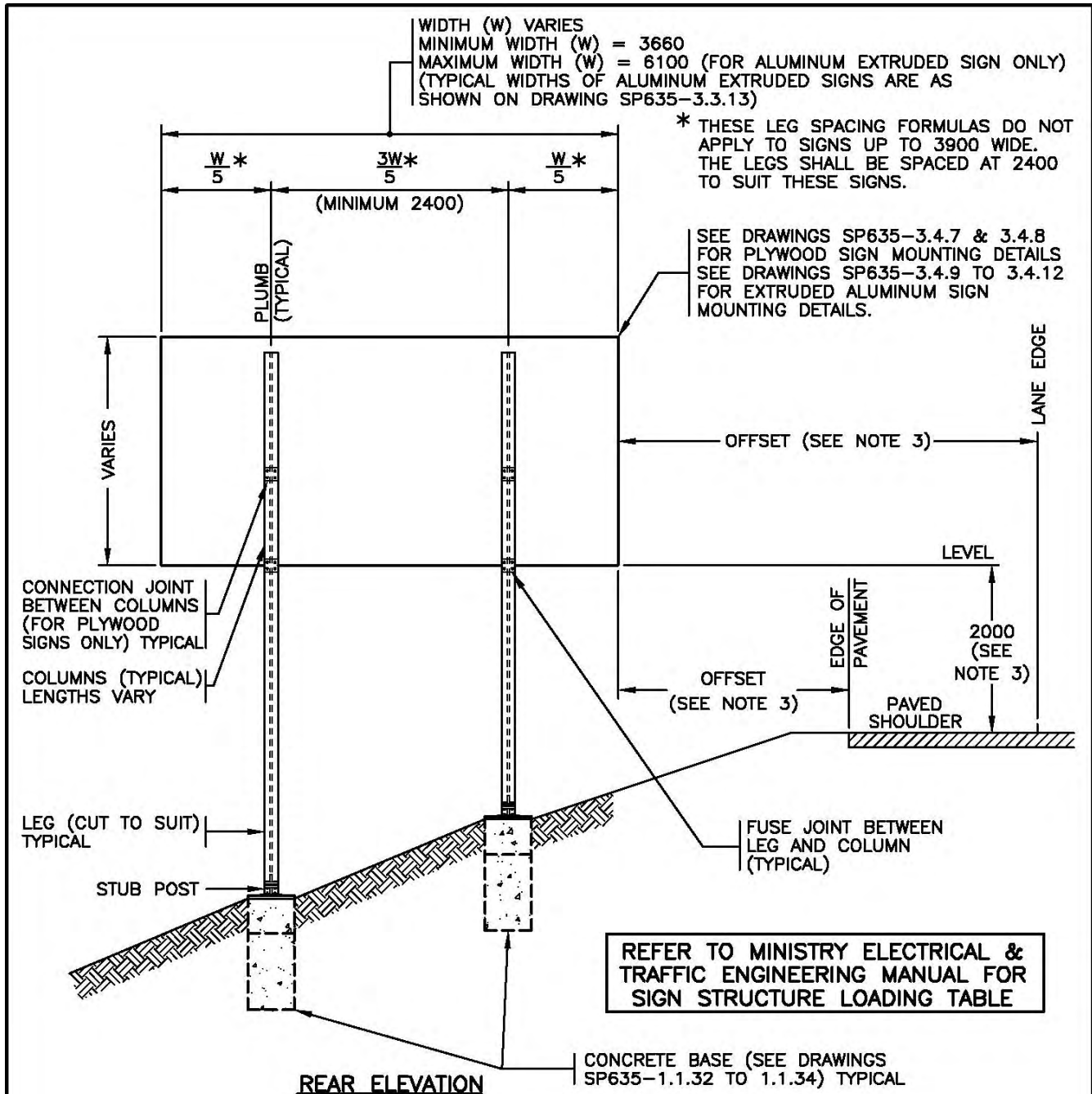

NOTES

1. SEE STANDARD SPECIFICATIONS & SPECIAL PROVISIONS FOR ADDITIONAL INFORMATION.
2. ALL DIMENSIONS ARE IN MILLIMETRES UNLESS OTHERWISE NOTED. aaaa
3. MOUNTING HEIGHTS & OFFSETS SHALL FALL WITHIN THE RANGES NOTED IN THE MINISTRY MANUAL OF STANDARD TRAFFIC SIGNS & PAVEMENT MARKINGS.

NOT TO SCALE



No.	Revision	Date
E	GENERAL REVISION	APR 05
D	MOUNTING HEIGHTS & OFFSETS REFERED THE MINISTRY MANUAL OF STANDARD TRAFFIC SIGNS	NOV 98
C	SLOPE & BASE DWG. REFERENCES REV'D	AUG 96
B	SLOPE SHOWN & TYPICAL SIGN WIDTHS SHOWN	AUG 95
A	GENERAL REVISION	AUG 94

**TWO LEG BREAKAWAY SIGN STRUCTURE
 INSTALLATION DETAIL**

Date **30/09/93** Approved **E.L. (Signature on File)**
 Chief Highway Engineer

SPECIFICATION
 DRAWING No.
SP635-3.4.1

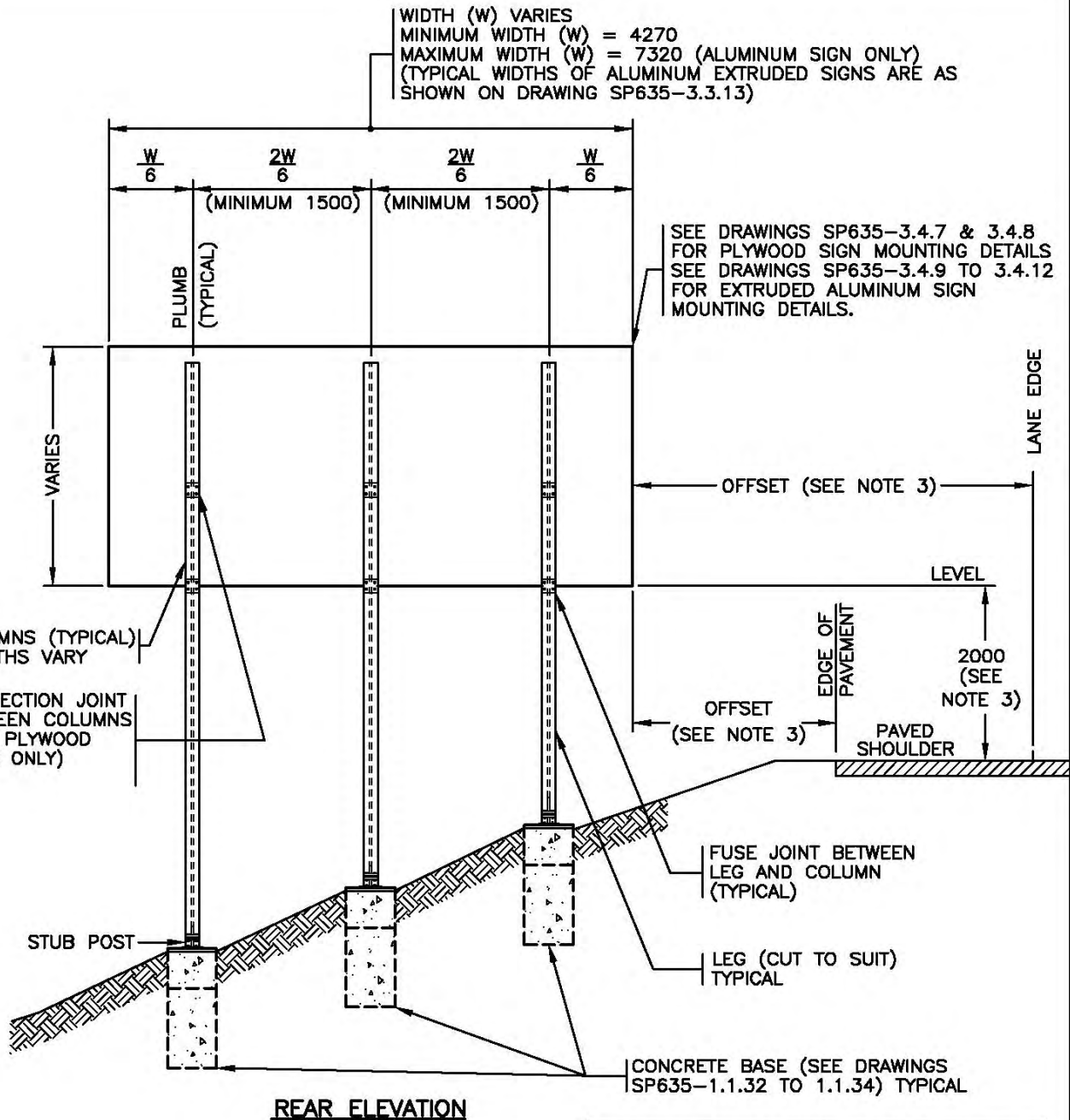

REAR ELEVATION

REFER TO MINISTRY ELECTRICAL & TRAFFIC ENGINEERING MANUAL FOR SIGN STRUCTURE LOADING TABLE

NOTES

1. SEE STANDARD SPECIFICATIONS & SPECIAL PROVISIONS FOR ADDITIONAL INFORMATION.
2. ALL DIMENSIONS ARE IN MILLIMETRES UNLESS OTHERWISE NOTED. aaaa
3. MOUNTING HEIGHTS & OFFSETS SHALL FALL WITHIN THE RANGES NOTED IN THE MINISTRY MANUAL OF STANDARD TRAFFIC SIGNS & PAVEMENT MARKINGS.

NOT TO SCALE



No.	Revision	Date
D	MOUNTING HEIGHTS & OFFSETS REFERED THE MINISTRY MANUAL OF STANDARD TRAFFIC SIGNS	NOV 98
C	SLOPE & BASE DWG. REFERENCES REV'D	AUG 96
B	SLOPE SHOWN & TYPICAL SIGN WIDTHS SHOWN	AUG 95
A	GENERAL REVISION	AUG 94

THREE LEG BREAKAWAY SIGN STRUCTURE INSTALLATION DETAILS

Date **30/09/93** Approved **E.L. (Signature on File)**
Chief Highway Engineer

SPECIFICATION DRAWING No. **SP635-3.4.2**

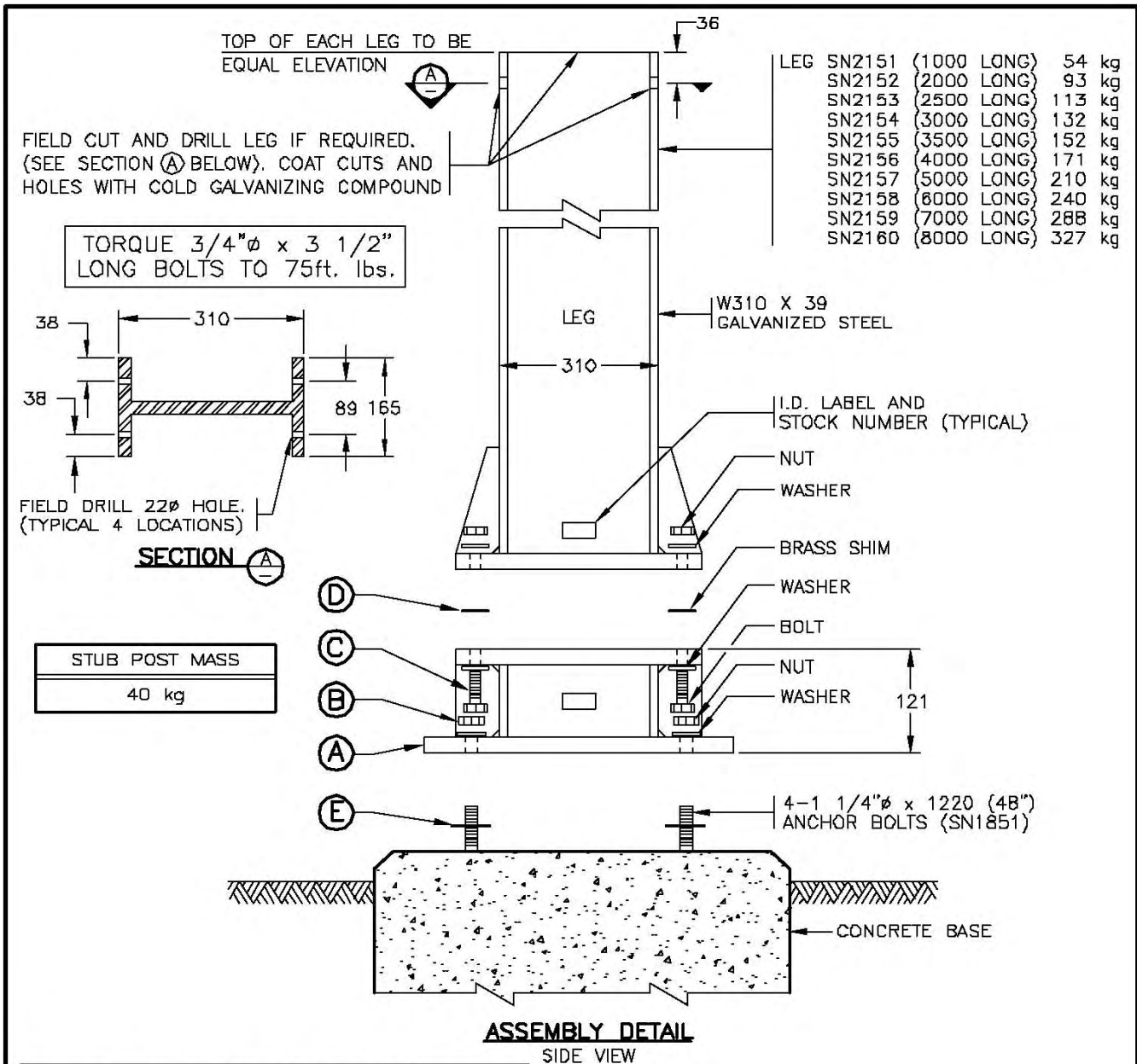

STUB POST KIT (SN2165)		
ITEM	QUANTITY	DESCRIPTION
A	1	GALVANIZED STEEL STUB POST
B	4	GALVANIZED NUT AND WASHER FOR 1 1/4"φ ANCHOR BOLT
C	4	3/4"φ x 3 1/2" LONG GALVANIZED BOLT, 2 WASHERS AND NUT
D	4	BRASS SHIMS (1 PER BOLT)
E	4	LEVELING SHIMS (MAX 4 PER BOLT)

NOTES

1. SEE STANDARD SPECIFICATIONS & SPECIAL PROVISIONS FOR ADDITIONAL INFORMATION.
2. ALL DIMENSIONS ARE IN MILLIMETRES UNLESS OTHERWISE NOTED.



NOT TO SCALE

No.	Revision	Date
F		
E		
D		
C		
B		
A	GENERAL REVISION	AUG 94

BREAKAWAY LEG AND STUB POST
INSTALLATION DETAILS

Date: 30/09/93
Approved: E.L. (Signature on File)
Chief Highway Engineer

SPECIFICATION
DRAWING No.
SP635-3.4.3

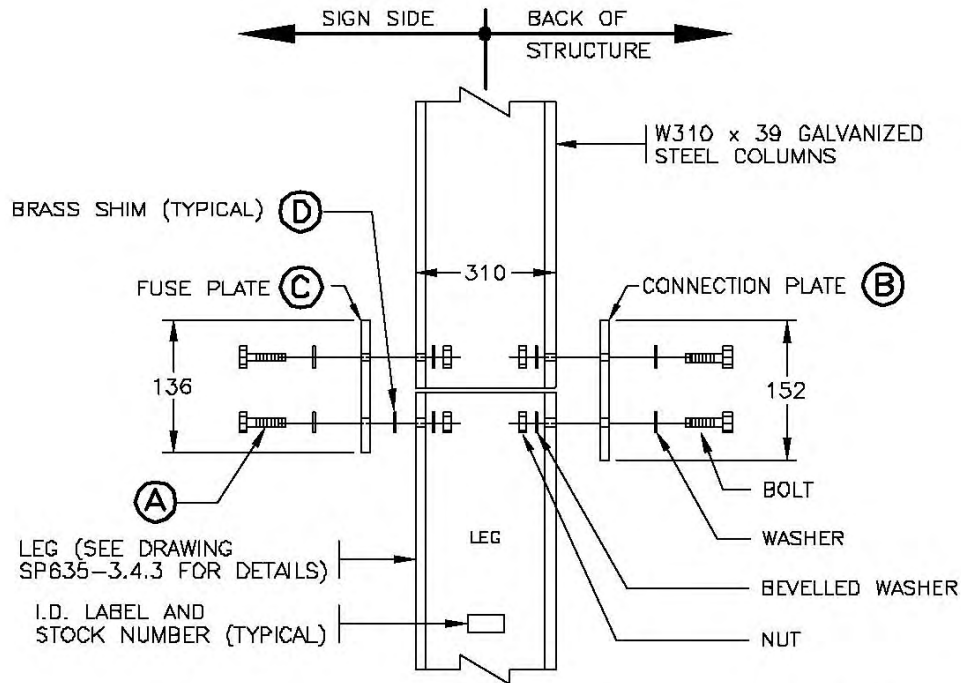

ASSEMBLY DETAIL
SIDE VIEW

TORQUE 3/4"φ x 2" LONG BOLTS TO 262ft. lbs.

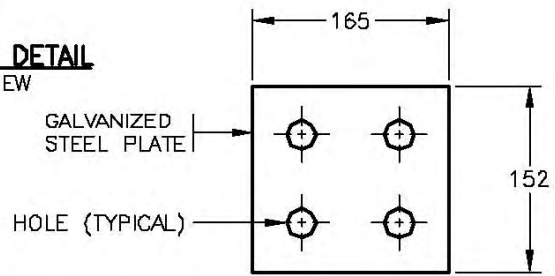

CONNECTION PLATE
(ITEM B)

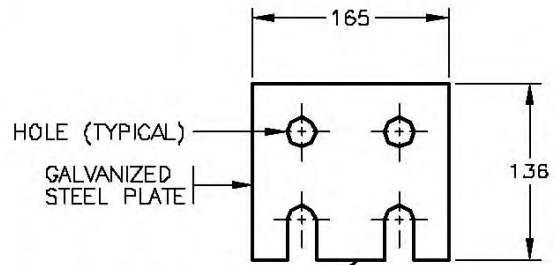

FUSE PLATE
(ITEM C)

FUSE JOINT KIT (5N2166)		
ITEM	QUANTITY	DESCRIPTION
A	8	3/4"φ x 2" LONG GALVANIZED BOLT, NUT, WASHER AND BEVELLED WASHER.
B	1	CONNECTION PLATE
C	1	FUSE PLATE
D	2	BRASS SHIMS

NOTES

- SEE STANDARD SPECIFICATIONS & SPECIAL PROVISIONS ^{aaaa} FOR ADDITIONAL INFORMATION.
- ALL DIMENSIONS ARE IN MILLIMETRES UNLESS OTHERWISE NOTED.

NOT TO SCALE



No.	Revision	Date
F		
E		
D		
C		
B		
A	GENERAL REVISION	AUG 94

**BREAKAWAY FUSE JOINT
INSTALLATION DETAILS**

Date **30/09/93** Approved **E.L. (Signature on File)**
Chief Highway Engineer

SPECIFICATION
DRAWING No.
SP635-3.4.4

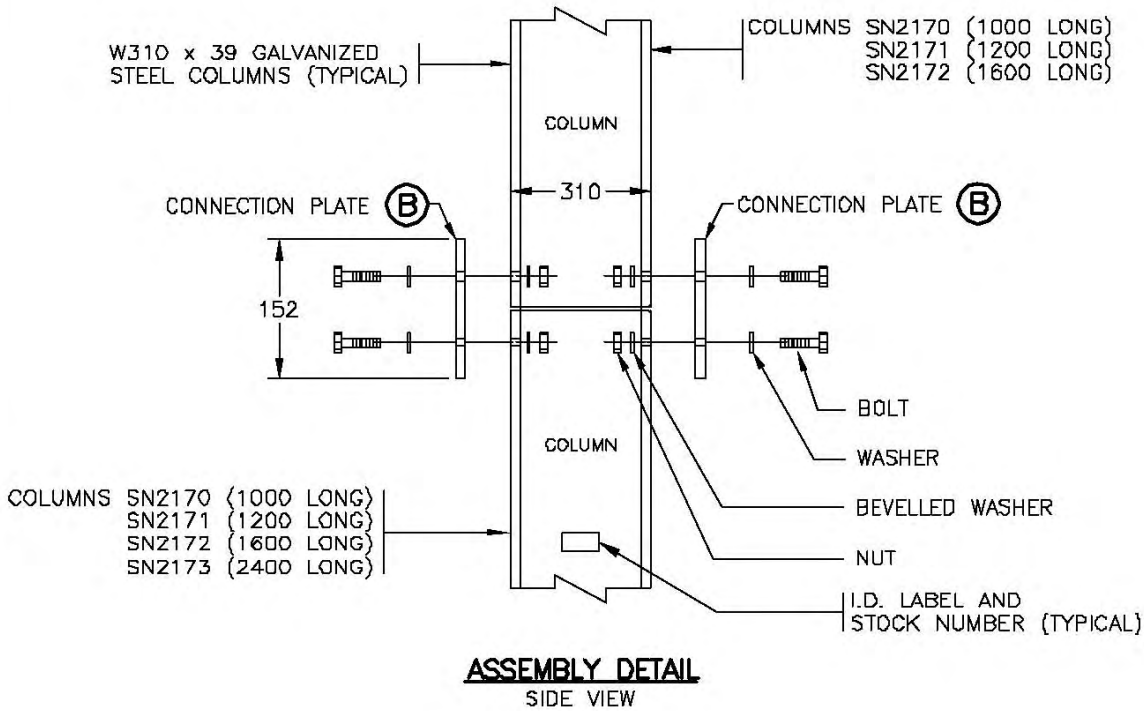

TORQUE 3/4"φ x 2" LONG BOLTS TO 262ft. lbs.

CONNECTION JOINT KIT (SN2167)		
ITEM	QUANTITY	DESCRIPTION
A	8	3/4"φ x 2" LONG GALVANIZED BOLT, NUT, WASHER AND BEVELLED WASHER.
B	2	CONNECTION PLATE

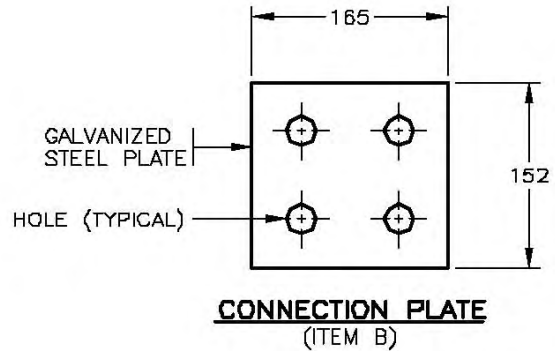

NOTES

- SEE STANDARD SPECIFICATIONS & SPECIAL PROVISIONS FOR ADDITIONAL INFORMATION.
- ALL DIMENSIONS ARE IN MILLIMETRES UNLESS OTHERWISE NOTED.

NOT TO SCALE



No.	Revision	Date
F		
E		
D		
C		
B		
A	GENERAL REVISION	AUG 94

**BREAKAWAY CONNECTION JOINT INSTALLATION
DETAILS (FOR PLYWOOD SIGN ONLY)**

Date **30/09/93** Approved **E.L. (Signature on File)**
Chief Highway Engineer

SPECIFICATION
DRAWING No.
SP635-3.4.5

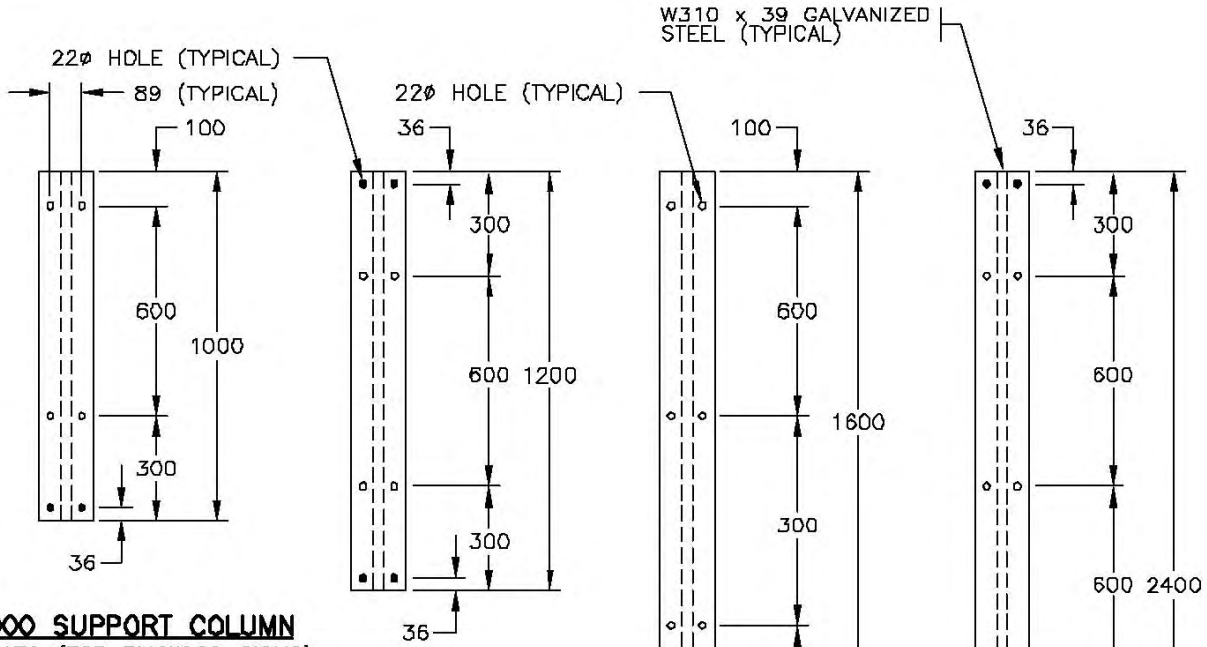

1000 SUPPORT COLUMN
SN2170 (FOR PLYWOOD SIGNS)

1200 SUPPORT COLUMN
SN2171 (FOR PLYWOOD SIGNS)

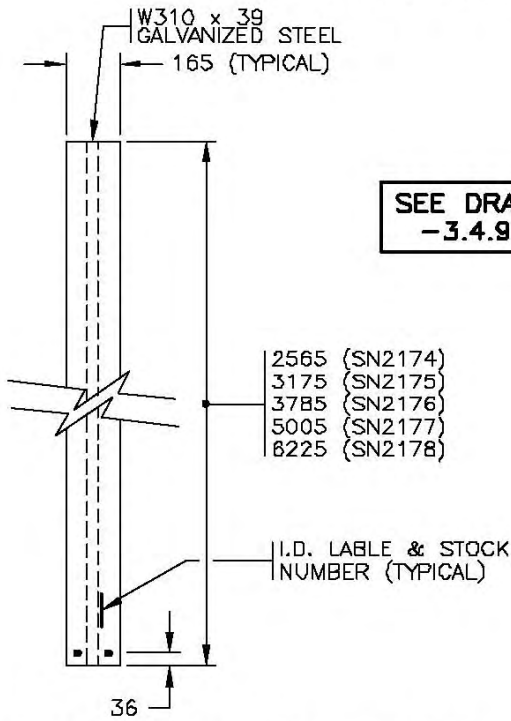

SUPPORT COLUMN FOR EXTRUDED ALUMINUM SIGNS

- 2565 (SN2174)
- 3175 (SN2175)
- 3785 (SN2176)
- 5005 (SN2177)
- 8225 (SN2178)

I.D. LABEL & STOCK NUMBER (TYPICAL)

1600 SUPPORT COLUMN
SN2172 (FOR PLYWOOD SIGNS)

SEE DRAWINGS SP635-3.4.7 AND -3.4.9 FOR COLUMN MASSES.

2400 SUPPORT COLUMN
SN2173 (FOR PLYWOOD SIGNS)

NOTES

1. SEE STANDARD SPECIFICATIONS & SPECIAL PROVISIONS FOR ADDITIONAL INFORMATION.
2. HOLES SHOWN ● ARE FOR FUSE OR CONNECTION PLATES ONLY
3. HOLES SHOWN ○ ARE FOR WOOD BATTENS ONLY
4. ALL DIMENSIONS ARE IN MILLIMETRES UNLESS OTHERWISE NOTED.

SCALE 1:20



No.	Revision	Date
F		
E		
D		
C		
B		
A	GENERAL REVISION	AUG 94

BREAKAWAY SIGN SUPPORT COLUMN DETAILS

Date: **30/09/93** Approved: **E.L. (Signature on File)**
Chief Highway Engineer

SPECIFICATION DRAWING No. **SP635-3.4.6**

COLUMNS		
MINISTRY STOCK NUMBER	LENGTH	MASS (kg)
SN2170	1000	39
SN2171	1200	47
SN2172	1600	63
SN2173	2400	94

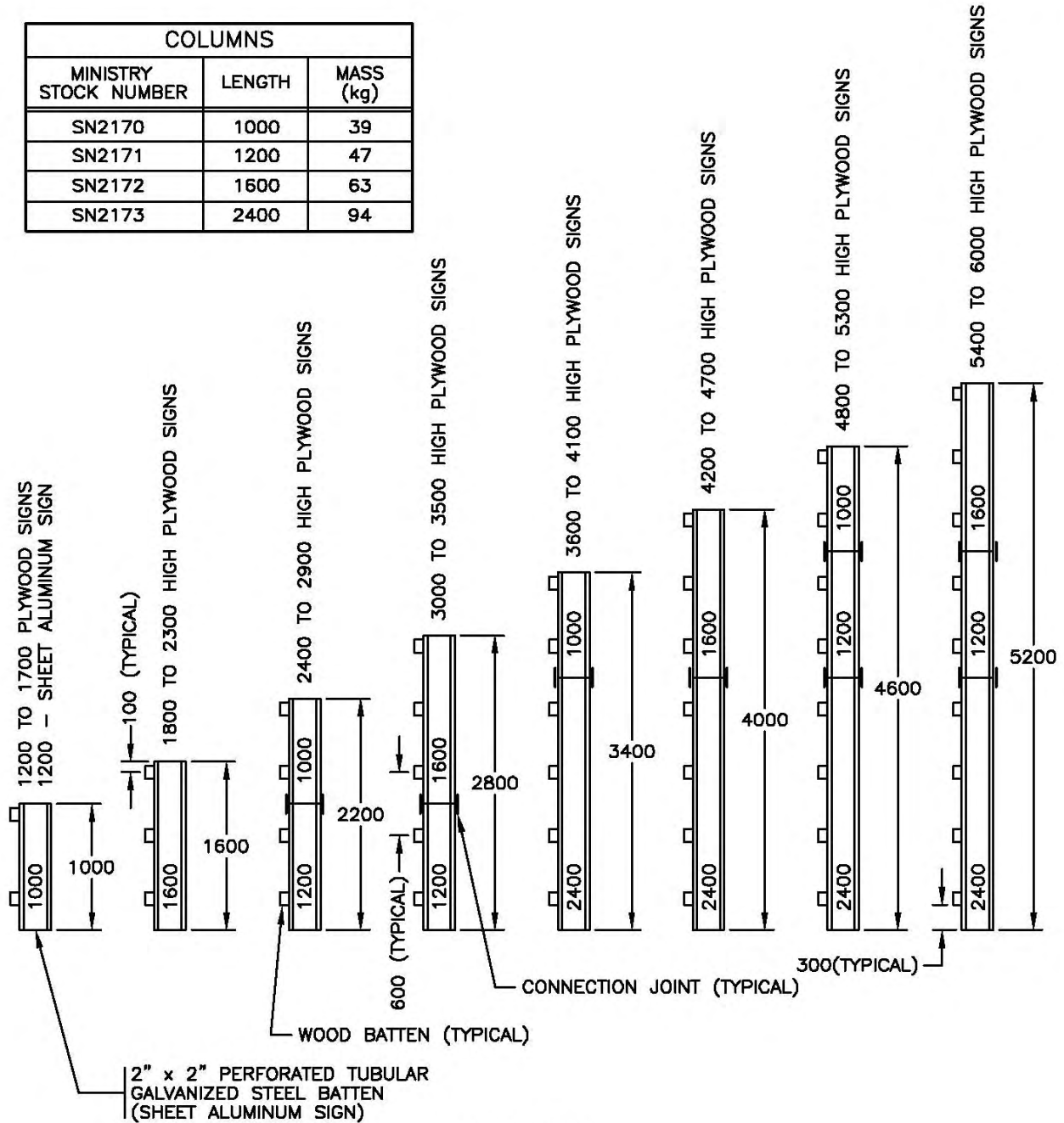

SIDE VIEW

NOTES

- SEE STANDARD SPECIFICATIONS & SPECIAL PROVISIONS FOR ADDITIONAL INFORMATION.
- ALL DIMENSIONS ARE IN MILLIMETRES UNLESS OTHERWISE NOTED.

NOT TO SCALE



No.	Revision	Date
F		
E		
D		
C		
B	GENERAL REVISION	APR 05
A	GENERAL REVISION	AUG 94

SIGN MOUNTING DETAILS ON BREAKAWAY SIGN STRUCTURE

Date Approved
30/09/93 **E.L.** (Signature on File)
 Chief Highway Engineer

SPECIFICATION DRAWING No.
SP635-3.4.7

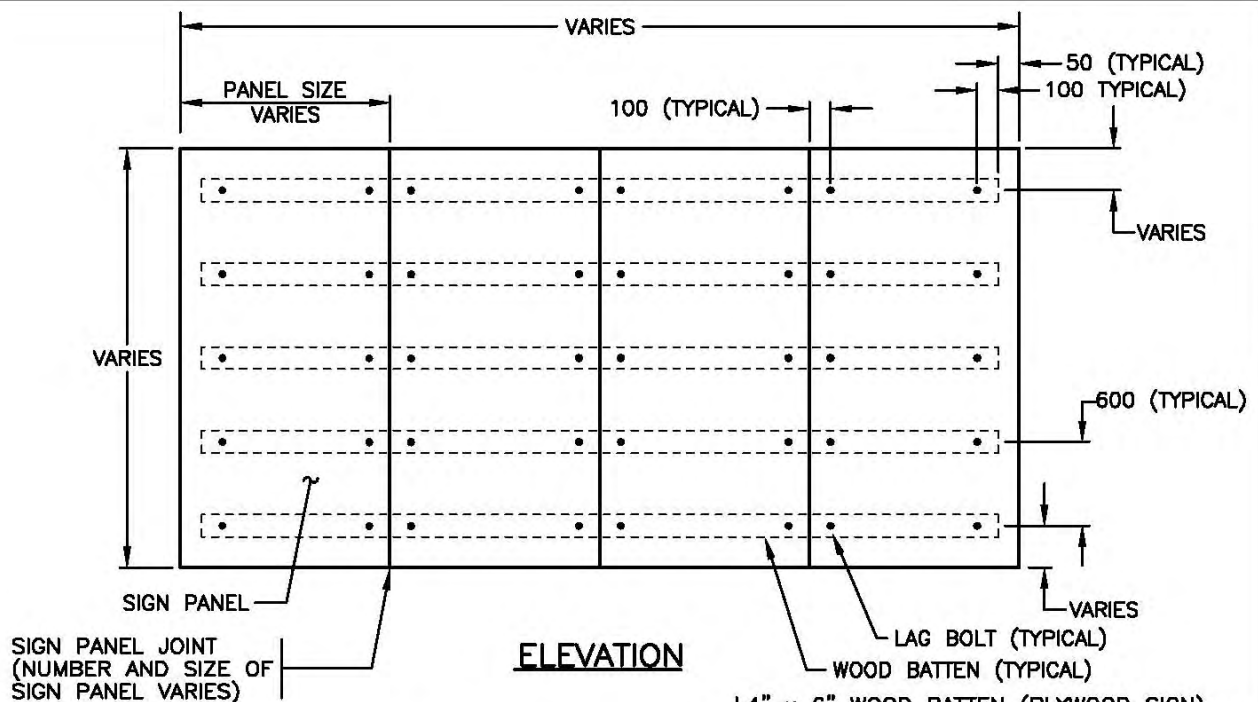

ELEVATION

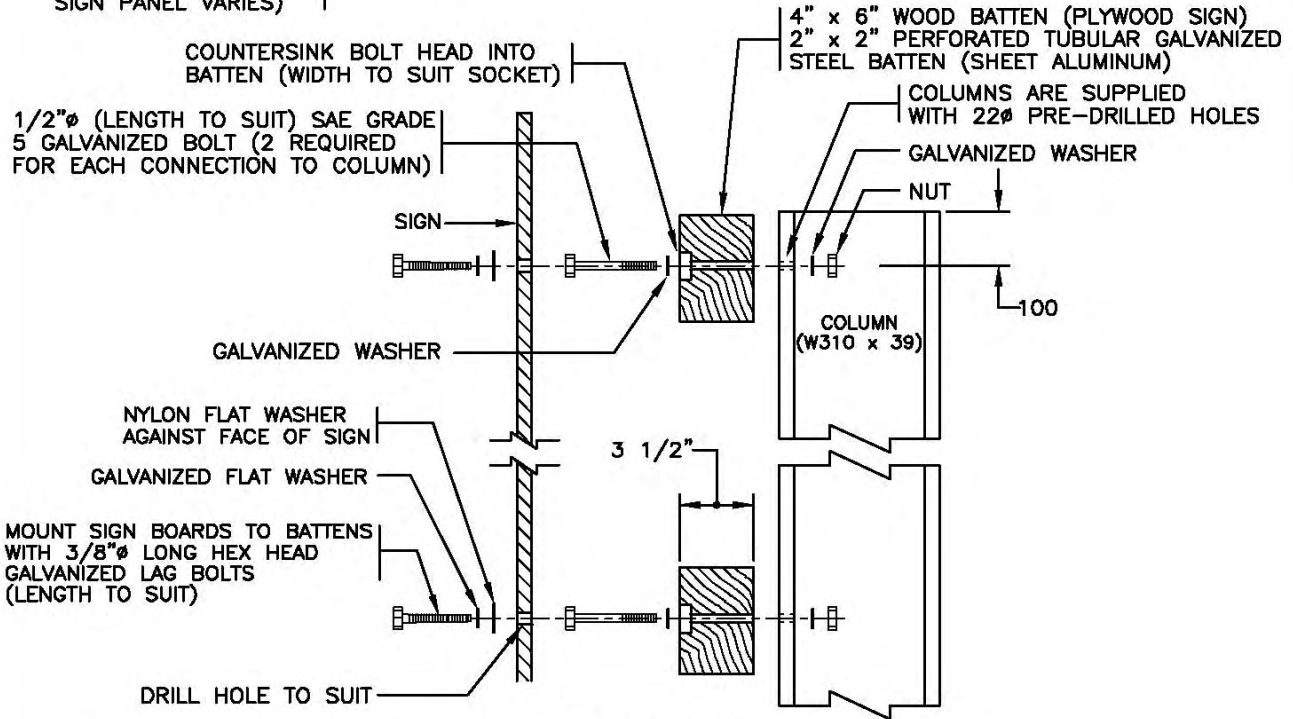

SIDE VIEW

NOTES

1. SEE STANDARD SPECIFICATIONS & SPECIAL PROVISIONS FOR ADDITIONAL INFORMATION.
2. ALL DIMENSIONS ARE IN MILLIMETRES UNLESS OTHERWISE NOTED.



NOT TO SCALE

No.	Revision	Date
F		
E		
D		
C		
B	GENERAL REVISION	APR 05
A	GENERAL REVISION	AUG 94

**SIGN MOUNTING DETAILS
ON BREAKAWAY SIGN STRUCTURE**

Date: **30/09/93**
 Approved: **E.L. (Signature on File)**
 Chief Highway Engineer

SPECIFICATION
 DRAWING No.
SP635-3.4.8

COLUMNS		
MINISTRY STOCK NUMBER	LENGTH	MASS (kg)
SN2174	2565	100
SN2175	3175	124
SN2176	3785	148
SN2177	5005	195
SN2178	6225	243

WHERE CUTTING COLUMN COAT EDGE WITH COLD GALVANIZING COMPOUND.

EXTRUDED ALUMINUM SIGN SECTION (305 HIGH)

CONNECTION BOLTS (SUPPLIED WITH SIGN) SEE DRAWINGS SP635-3.4.10 TO 3.4.12 FOR DETAILS (TYPICAL)

TOTAL MASS
EACH EXTRUDED ALUMINUM SIGN SECTION = 4 kg/m

I.D. LABEL AND STOCK NUMBER (TYPICAL)

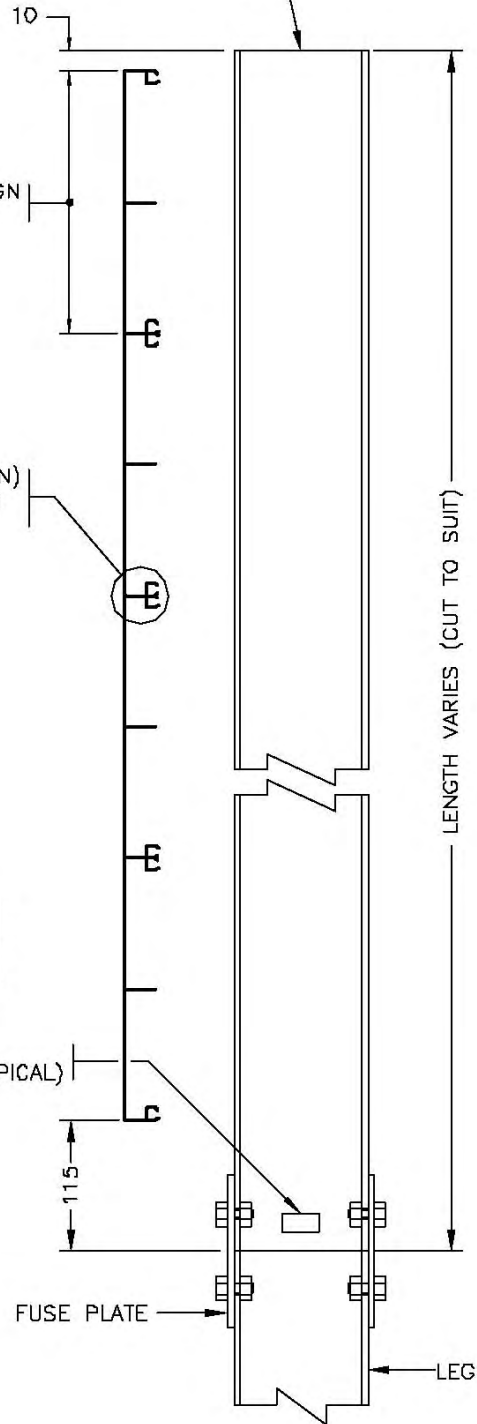

NOTES

- SEE STANDARD SPECIFICATIONS & SPECIAL PROVISIONS FOR ADDITIONAL INFORMATION.
- ALL DIMENSIONS ARE IN MILLIMETRES UNLESS OTHERWISE NOTED.

aaaa

NOT TO SCALE



No.	Revision	Date
F		
E		
D		
C		
B		
A	NEW DRAWING NUMBER	OCT 97

EXTRUDED ALUMINUM SIGN MOUNTING DETAILS ON BREAKAWAY SIGN STRUCTURE

Date **18/11/94** Approved **E.L. (Signature on File)**
Chief Highway Engineer

SPECIFICATION DRAWING No. **SP635-3.4.9**

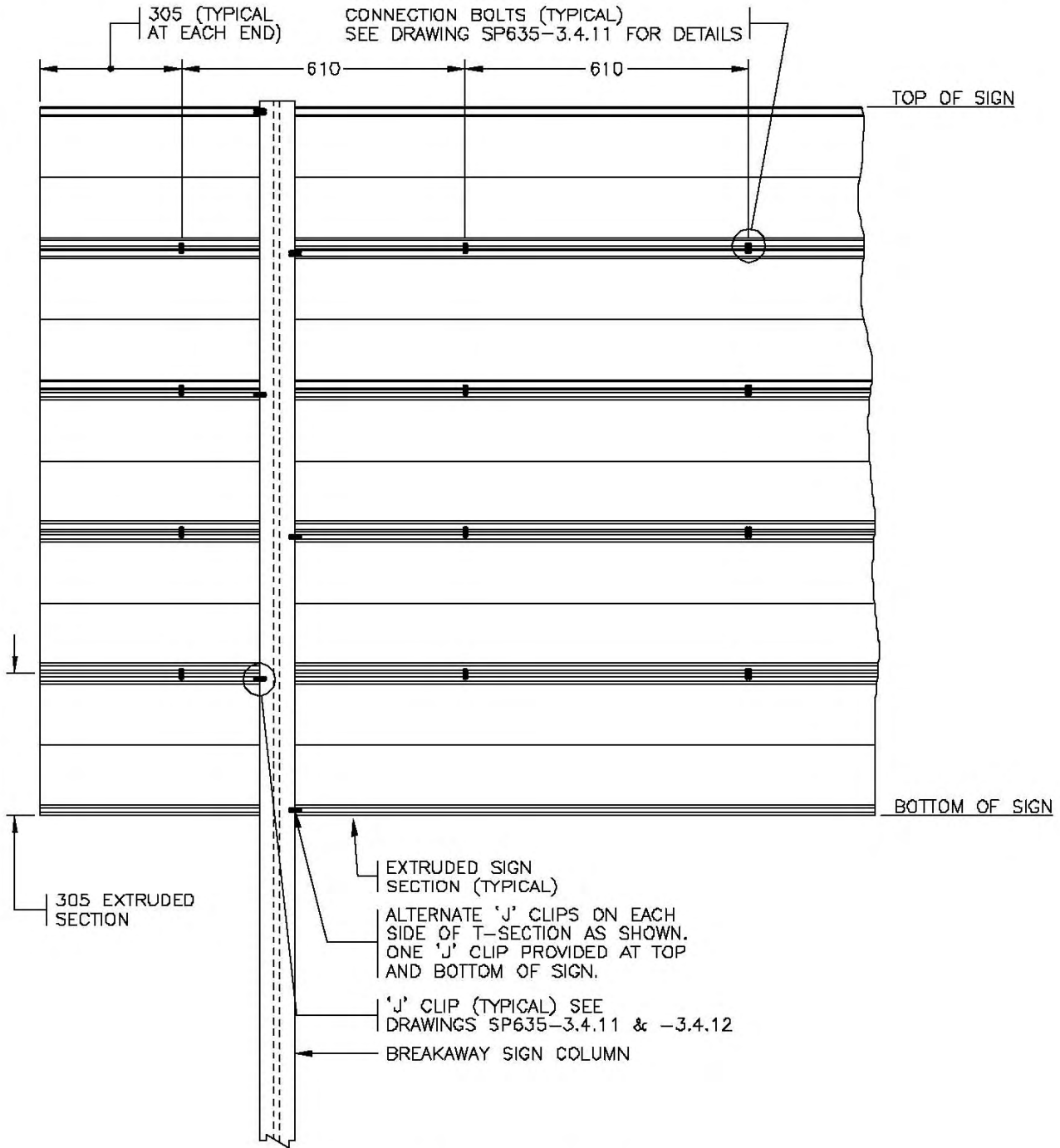

REAR VIEW OF SIGN

SEE DRAWING SP635-3.4.9 FOR NOTES AND ADDITIONAL DETAILS.



NOT TO SCALE

No.	Revision	Date
F		
E		
D		
C		
B	NEW DRAWING NUMBER	OCT 97
A	END HOLE SPACING REVISED	AUG 95

**EXTRUDED ALUMINUM SIGN MOUNTING
DETAILS ON BREAKAWAY SIGN STRUCTURE**

Date: **18/11/94** Approved: **E.L. (Signature on File)**
Chief Highway Engineer

SPECIFICATION
DRAWING No.
SP635-3.4.10

'J' CLIPS (SUPPLIED WITH SIGN SECTION)
SEE DRAWING SP635-3.4.12 FOR DETAILS
(TYPICAL)

ADJUST SIGN SECTIONS
SO THAT SIGN MESSAGES
LINE UP (TYPICAL)

305 SECTION
(TYPICAL)

SLOTTED HOLES SUPPLIED
IN EXTRUDED ALUMINUM
SECTIONS

CONNECT SIGN SECTIONS
TOGETHER EVERY 610
(305 AT ENDS) WITH
3/8"Ø x 1" LONG
STAINLESS STEEL JOINER
BOLTS, NUTS AND
FLATWASHERS (SUPPLIED
WITH SIGN SECTIONS)

BREAKAWAY SIGN
COLUMN

ASSEMBLY VIEW

**TORQUE JOINER BOLTS AND
'J' CLIPS TO 19 ft. lbs.**

aaaa

SEE DRAWING SP635-3.4.9 FOR
NOTES AND ADDITIONAL DETAILS.



NOT TO SCALE

No.	Revision	Date
F		
E		
D		
C		
B	NEW DRAWING NUMBER	OCT 97
A	END HOLE SPACING REVISED	AUG 95

**EXTRUDED ALUMINUM SIGN MOUNTING
DETAILS ON BREAKAWAY SIGN STRUCTURE**

Date **18/11/94** Approved **E.L. (Signature on File)**
Chief Highway Engineer

SPECIFICATION
DRAWING No.
SP635-3.4.11

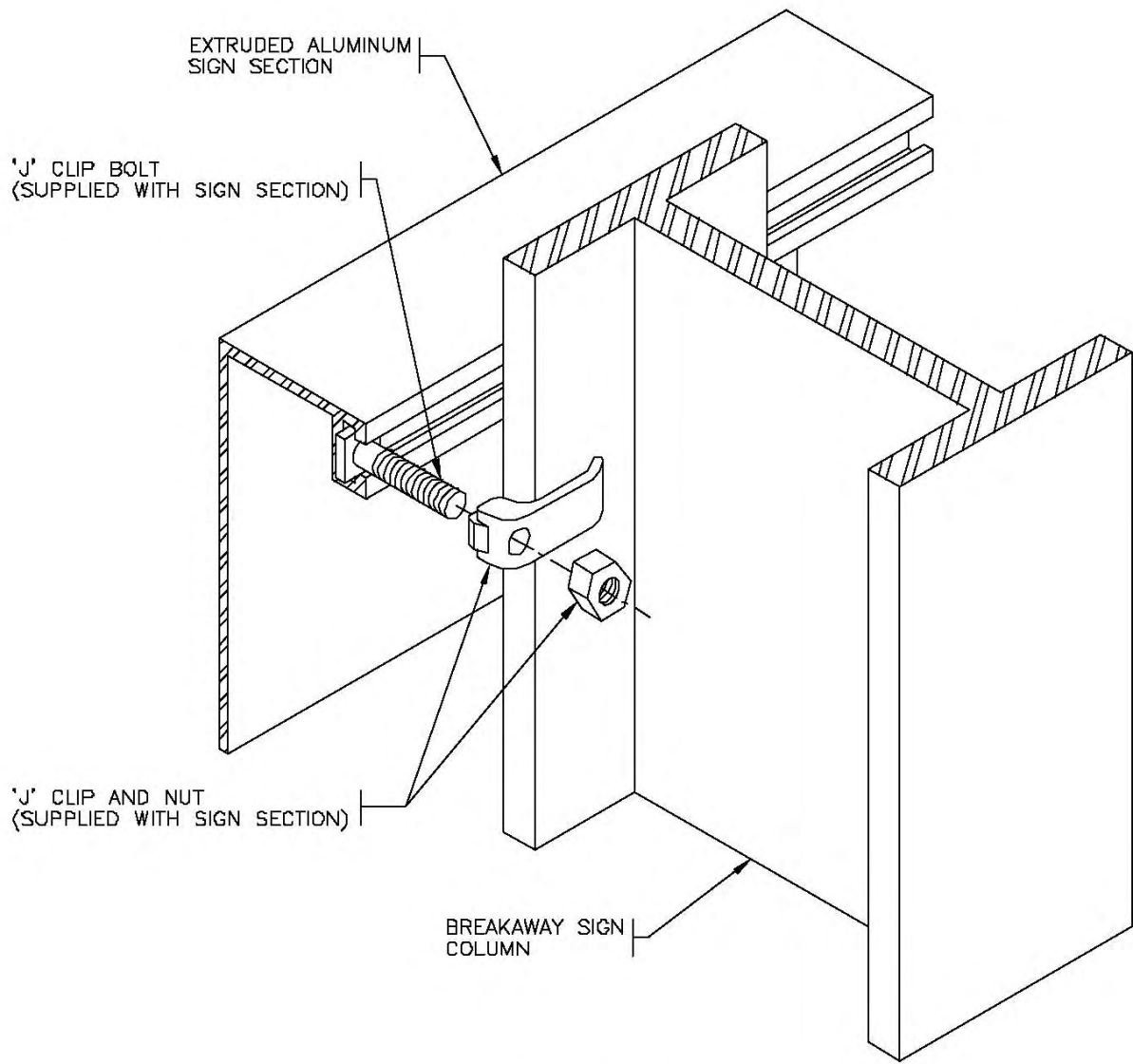

ASSEMBLY VIEW

TORQUE JOINER BOLTS AND 'J' CLIPS TO 19 ft. lbs.

aaaa

SEE DRAWING SP635-3.4.9 FOR NOTES AND ADDITIONAL DETAILS.



NOT TO SCALE

No.	Revision	Date
F		
E		
D		
C		
B		
A	NEW DRAWING NUMBER	OCT 97

EXTRUDED ALUMINUM SIGN MOUNTING DETAILS ON BREAKAWAY SIGN STRUCTURE		
Date	Approved	SPECIFICATION DRAWING No.
18/11/94	E.L. (Signature on File) Chief Highway Engineer	SP635-3.4.12

SIGN HEIGHT	NUMBER OF BOLTS
UP TO 750 HIGH	2
751 TO 1260 HIGH	3

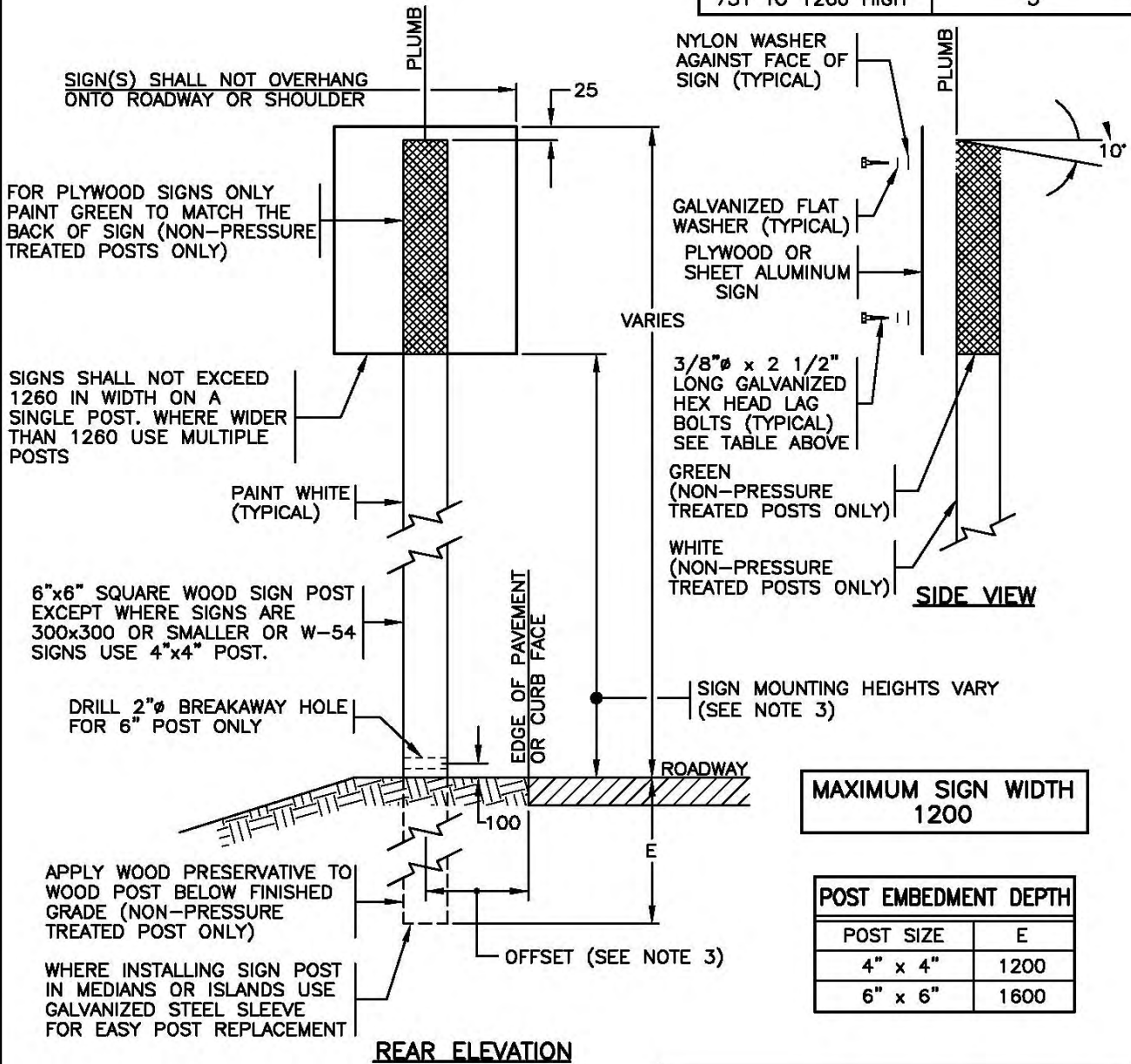

NOTES

- SEE STANDARD SPECIFICATIONS & SPECIAL PROVISIONS FOR ADDITIONAL INFORMATION.
- ALL DIMENSIONS ARE IN MILLIMETRES UNLESS OTHERWISE NOTED. aaaa
- MOUNTING HEIGHTS & OFFSETS SHALL FALL WITHIN THE RANGES NOTED IN THE MINISTRY MANUAL OF STANDARD TRAFFIC SIGNS & PAVEMENT MARKINGS.

REFER TO MINISTRY ELECTRICAL & TRAFFIC ENGINEERING MANUAL FOR SIGN STRUCTURE LOADING TABLE



NOT TO SCALE

No.	Revision	Date
F	REF. TO NON-PRESSURE TREATED POSTS	APR 05
E	MOUNTING HEIGHTS & OFFSETS REFERED THE MINISTRY MANUAL OF STANDARD TRAFFIC SIGNS	NOV 98
D	PAINTING NOTE REVISED	NOV 98
C	REDRAWN & SIGN MOUNTING HEIGHTS REVISED	DEC 96
B	MOUNTING HEIGHT & MAX. SIGN WIDTH REVISED	AUG 95

SINGLE WOOD POST SIGN STRUCTURE INSTALLATION DETAILS

Date **30/09/93** Approved **E.L. (Signature on File)**
Chief Highway Engineer

SPECIFICATION DRAWING No. **SP635-3.5.1**

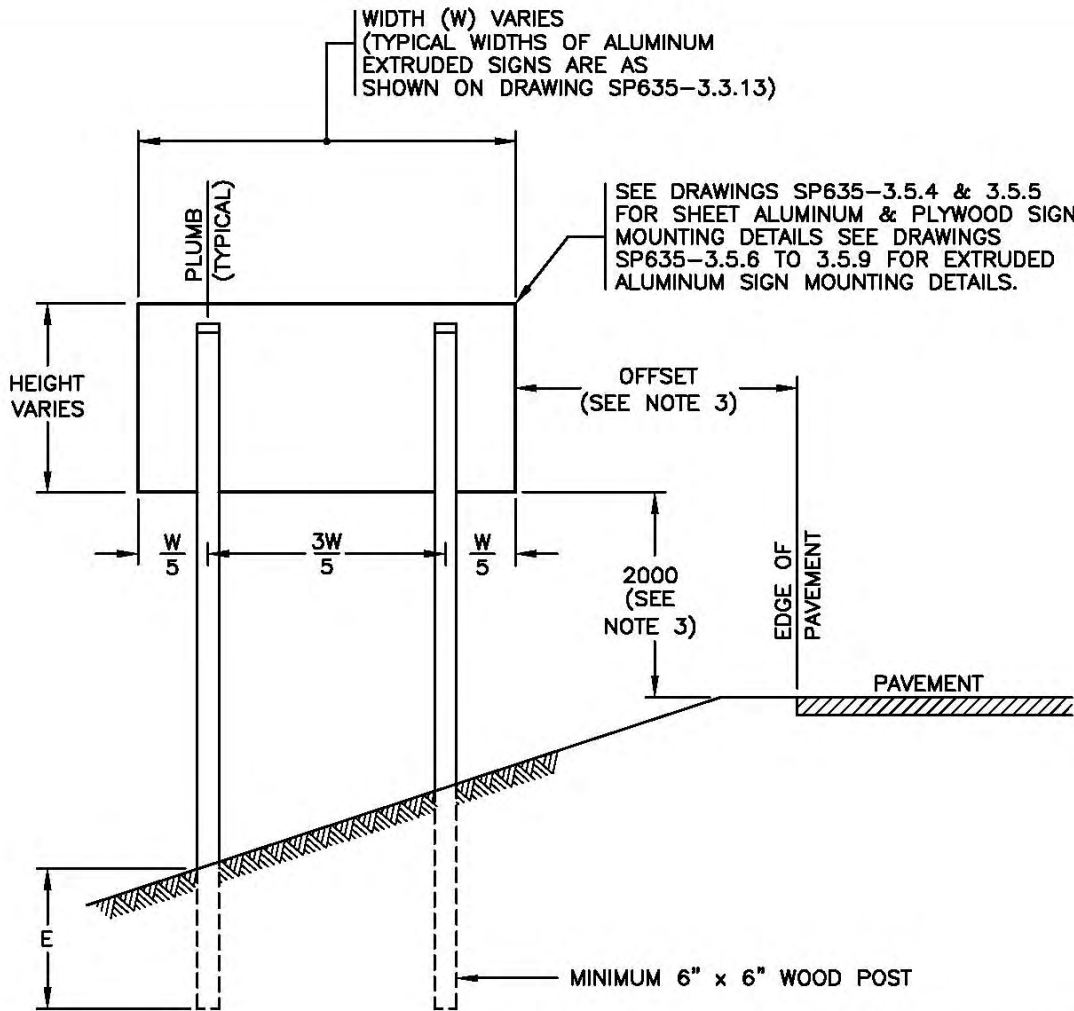

REAR ELEVATION

EMBEDMENT DEPTH	
POST SIZE	E
6" x 6"	1600
8" x 8"	2000
10" x 10"	2200

REFER TO MINISTRY ELECTRICAL & TRAFFIC ENGINEERING MANUAL FOR SIGN STRUCTURE LOADING TABLE

NOTES

1. SEE STANDARD SPECIFICATIONS & SPECIAL PROVISIONS FOR ADDITIONAL INFORMATION.
2. ALL DIMENSIONS ARE IN MILLIMETRES UNLESS OTHERWISE NOTED. aaaa
3. MOUNTING HEIGHTS & OFFSETS SHALL FALL WITHIN THE RANGES NOTED IN THE MINISTRY MANUAL OF STANDARD TRAFFIC SIGNS & PAVEMENT MARKINGS.

NOT TO SCALE



No.	Revision	Date
E	SHEET ALUMINUM SIGN ADDED	APR 05
D	MOUNTING HEIGHTS & OFFSETS REFERED THE MINISTRY MANUAL OF STANDARD TRAFFIC SIGNS	NOV 98
C	LOADING TABLE REFERENCE NOTE REVISED	AUG 96
B	SIGN OFFSET REVISED & TYP. SIGN WIDTH SHOWN	AUG 95
A	GENERAL REVISION	AUG 94

POST SIGN STRUCTURE
INSTALLATION DETAIL (TWO POST)

Date: 30/09/93
Approved: E.L. (Signature on File)
Chief Highway Engineer

SPECIFICATION
DRAWING No.
SP635-3.5.2

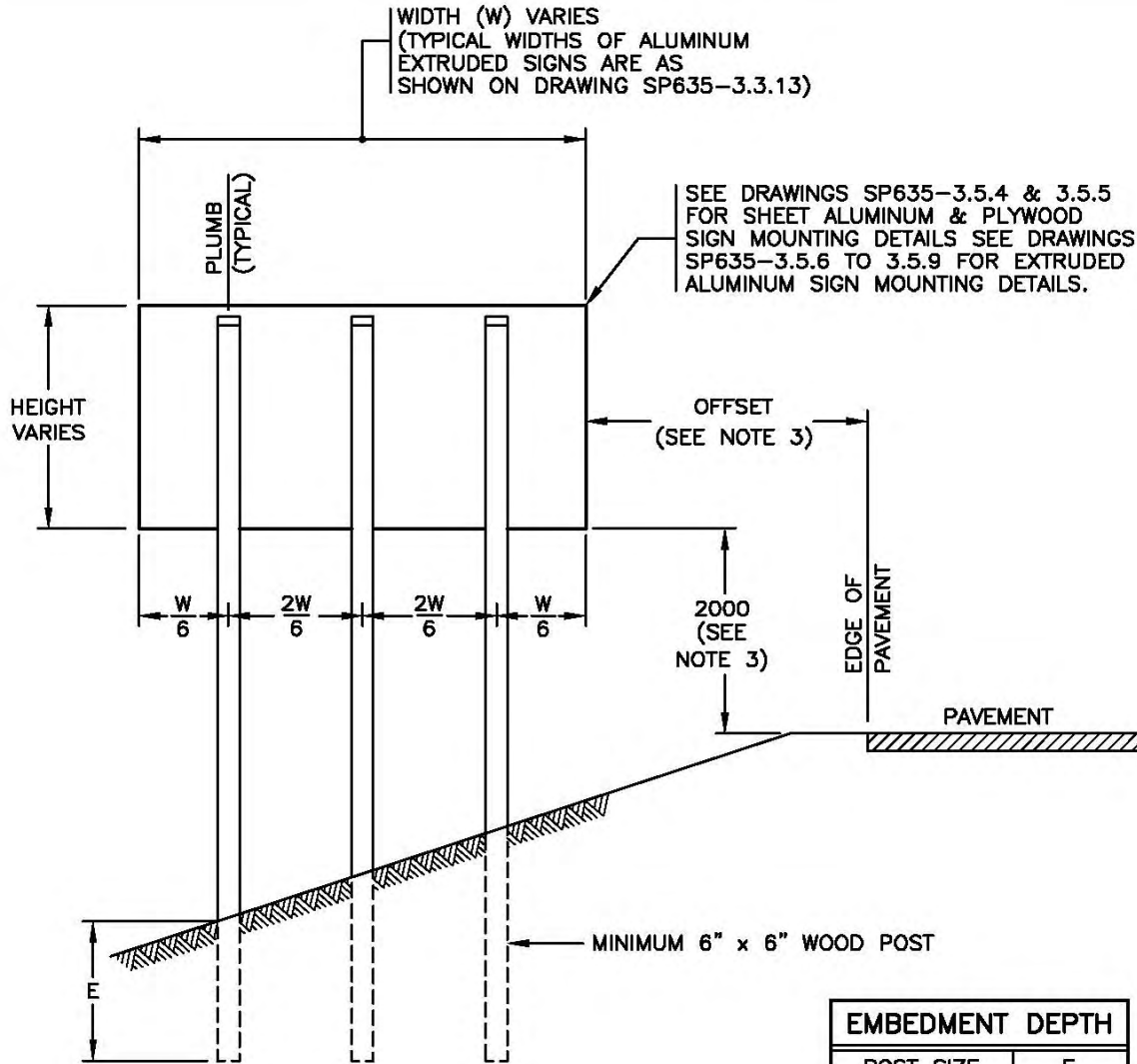

REAR ELEVATION

EMBEDMENT DEPTH	
POST SIZE	E
6" x 6"	1600
8" x 8"	2000
10" x 10"	2200

REFER TO MINISTRY ELECTRICAL & TRAFFIC ENGINEERING MANUAL FOR SIGN STRUCTURE LOADING TABLE

NOTES

1. SEE STANDARD SPECIFICATIONS & SPECIAL PROVISIONS FOR ADDITIONAL INFORMATION.
2. ALL DIMENSIONS ARE IN MILLIMETRES UNLESS OTHERWISE NOTED. aaaa
3. MOUNTING HEIGHTS & OFFSETS SHALL FALL WITHIN THE RANGES NOTED IN THE MINISTRY MANUAL OF STANDARD TRAFFIC SIGNS & PAVEMENT MARKINGS.

NOT TO SCALE



No.	Revision	Date
E	SHEET ALUMINUM SIGN ADDED	APR 05
D	MOUNTING HEIGHTS & OFFSETS REFERED THE MINISTRY MANUAL OF STANDARD TRAFFIC SIGNS	NOV 98
C	LOADING TABLE REFERENCE NOTE REVISED	AUG 96
B	SIGN OFFSET REVISED & TYP. SIGN WIDTH SHOWN	AUG 95
A	GENERAL REVISION	AUG 94

POST SIGN STRUCTURE INSTALLATION DETAILS (THREE POST)		
Date	Approved	SPECIFICATION DRAWING No.
30/09/93	E.L. (Signature on File) Chief Highway Engineer	SP635-3.5.3

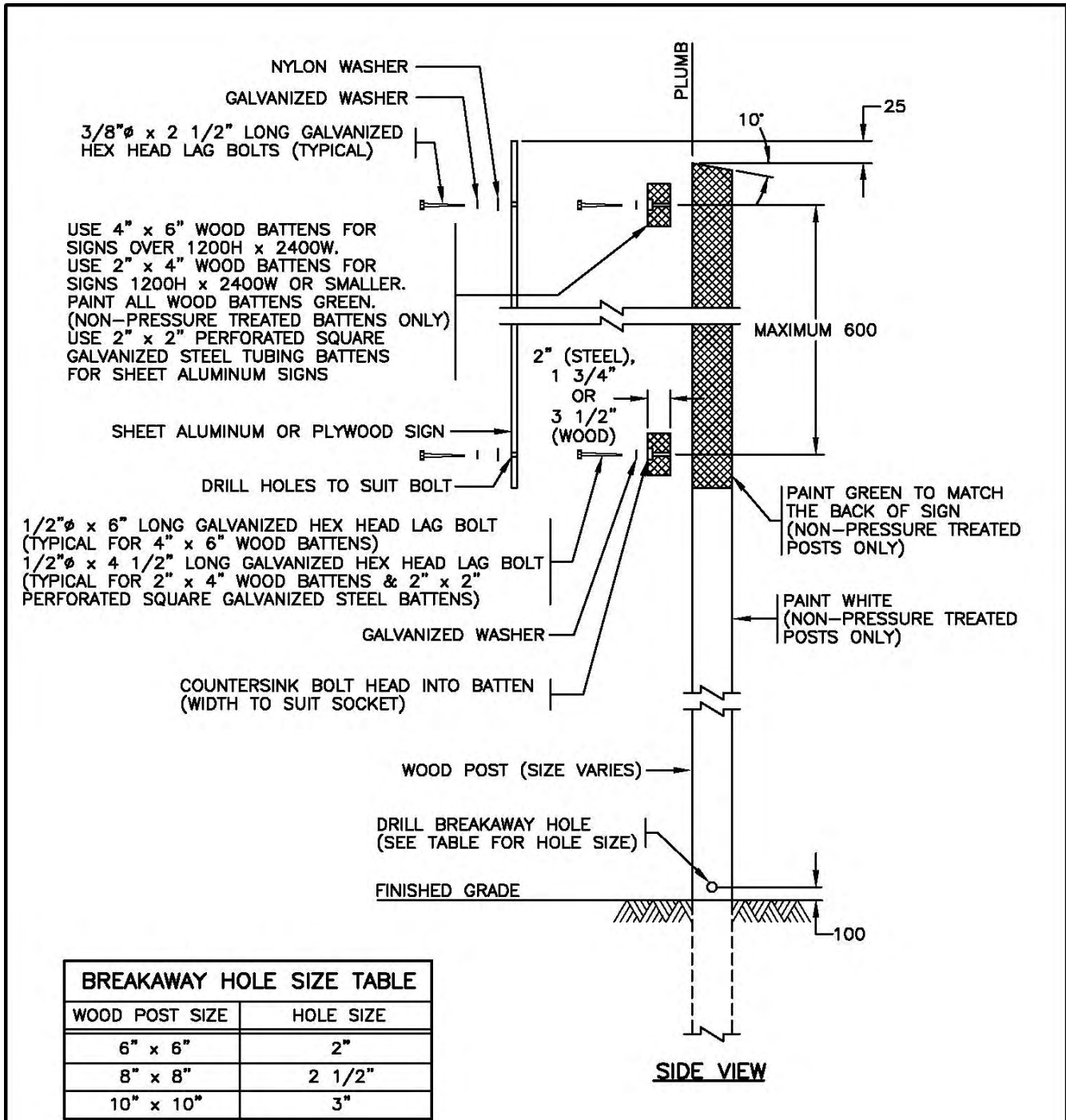

NOTES

- SEE STANDARD SPECIFICATIONS & SPECIAL PROVISIONS FOR ADDITIONAL INFORMATION.
- ALL DIMENSIONS ARE IN MILLIMETRES UNLESS OTHERWISE NOTED

NOT TO SCALE



No.	Revision	Date	SIGN INSTALLATION DETAILS ON WOOD POSTS (2 & 3 POST STRUCTURES)		SPECIFICATION DRAWING No.
F			Date	Approved	SP635-3.5.4
E			30/09/93	E.L. (Signature on File)	
D				Chief Highway Engineer	
C	GENERAL REVISION	APR 05			
B	ANGLE CUT ADDED TO TOP OF POST	AUG 95			
A	GENERAL REVISION	AUG 94			

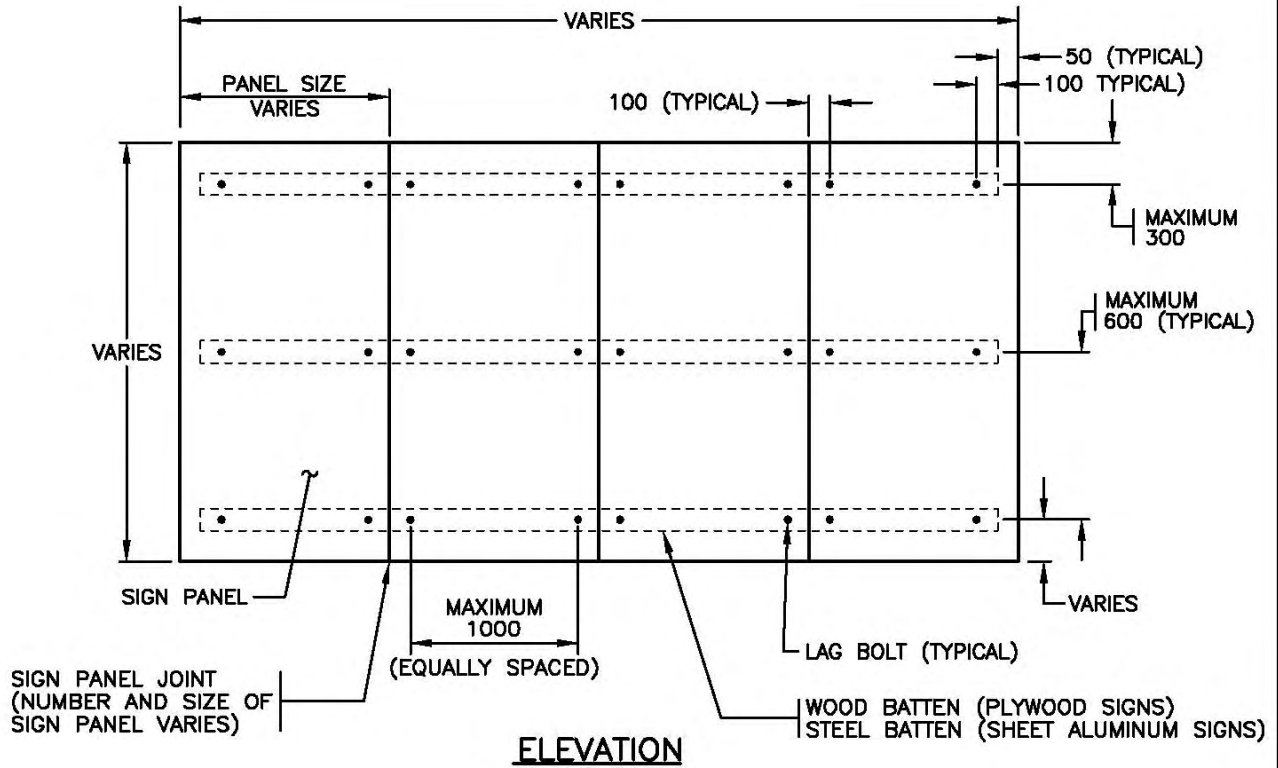

ELEVATION

NOTES

1. SEE STANDARD SPECIFICATIONS & SPECIAL PROVISIONS FOR ADDITIONAL INFORMATION.
2. ALL DIMENSIONS ARE IN MILLIMETRES UNLESS OTHERWISE NOTED

TOTAL MASS
SIGNBOARD = 10 kg/m ²

NOT TO SCALE



No.	Revision	Date
F		
E		
D		
C		
B	SHEET ALUMINUM SIGN ADDED	APR 05
A	GENERAL REVISION	AUG 94

SIGN INSTALLATION DETAILS ON WOOD POSTS		SPECIFICATION DRAWING No. SP635-3.5.5
Date	Approved	
30/09/93	E.L. (Signature on File)	
	Chief Highway Engineer	

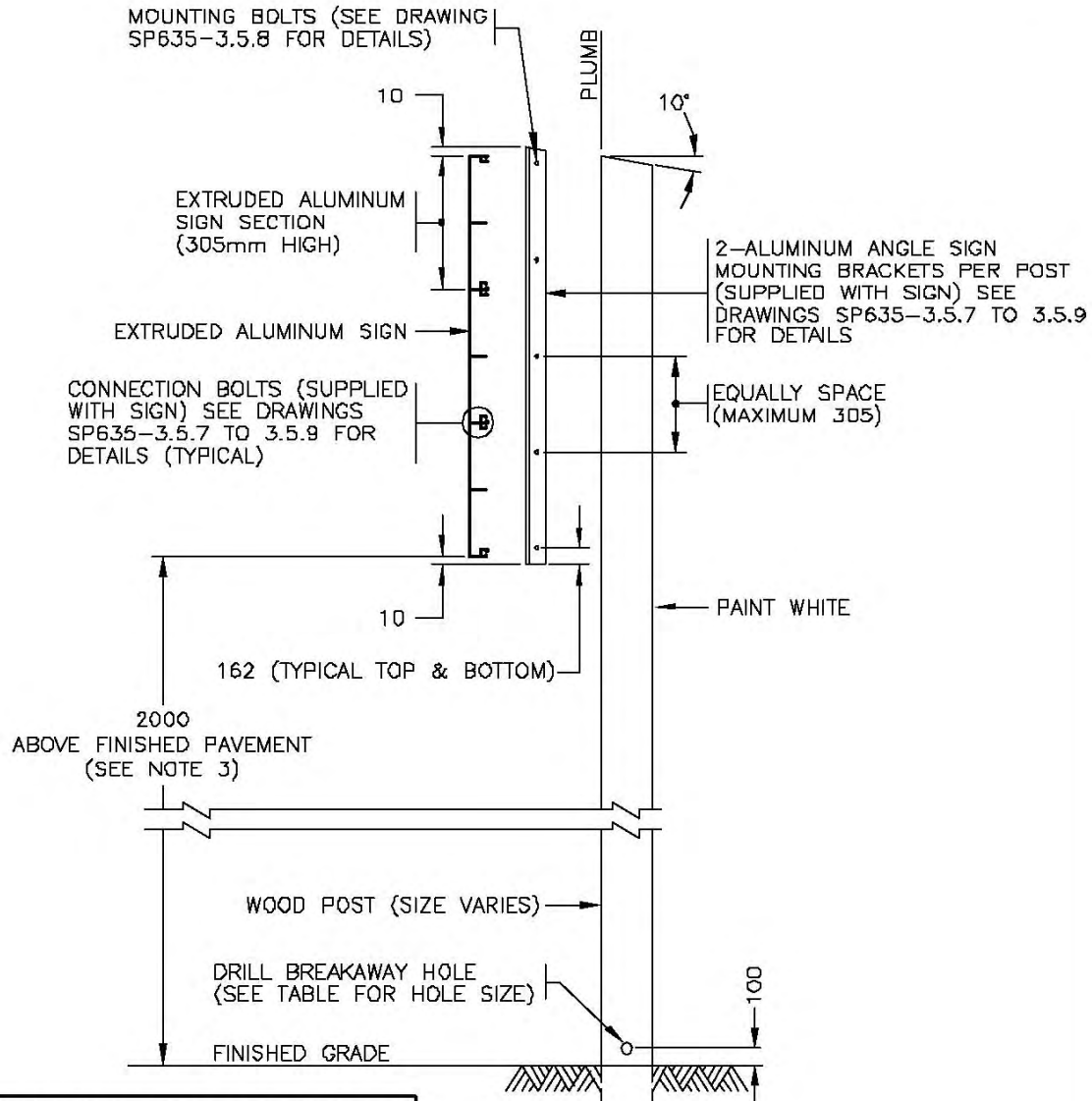

WOOD POST SIZE	HOLE SIZE
6" x 6"	2"
8" x 8"	2 1/2"
10" x 10"	3"

SIDE VIEW

NOTES

- SEE STANDARD SPECIFICATIONS & SPECIAL PROVISIONS FOR ADDITIONAL INFORMATION.
- ALL DIMENSIONS ARE IN MILLIMETRES UNLESS OTHERWISE NOTED.
- MOUNTING HEIGHTS & OFFSETS SHALL FALL WITHIN THE RANGES NOTED IN THE MINISTRY MANUAL OF STANDARD TRAFFIC SIGNS & PAVEMENT MARKINGS.

NOT TO SCALE

aaaa	TOTAL MASS
	EACH EXTRUDED ALUMINUM SIGN SECTION = 4 kg/m



No.	Revision	Date
E		
D		
C		
B	MOUNTING HEIGHTS & OFFSETS REFERED THE MINISTRY MANUAL OF STANDARD TRAFFIC SIGNS	NOV 98
A	ANGLE CUT ADDED ON TOP OF POST	AUG 95

EXTRUDED ALUMINUM SIGN INSTALLATION DETAILS ON WOOD POSTS		
Date	Approved	SPECIFICATION DRAWING No.
17/11/94	E.L. (Signature on File) Chief Highway Engineer	SP635-3.5.6

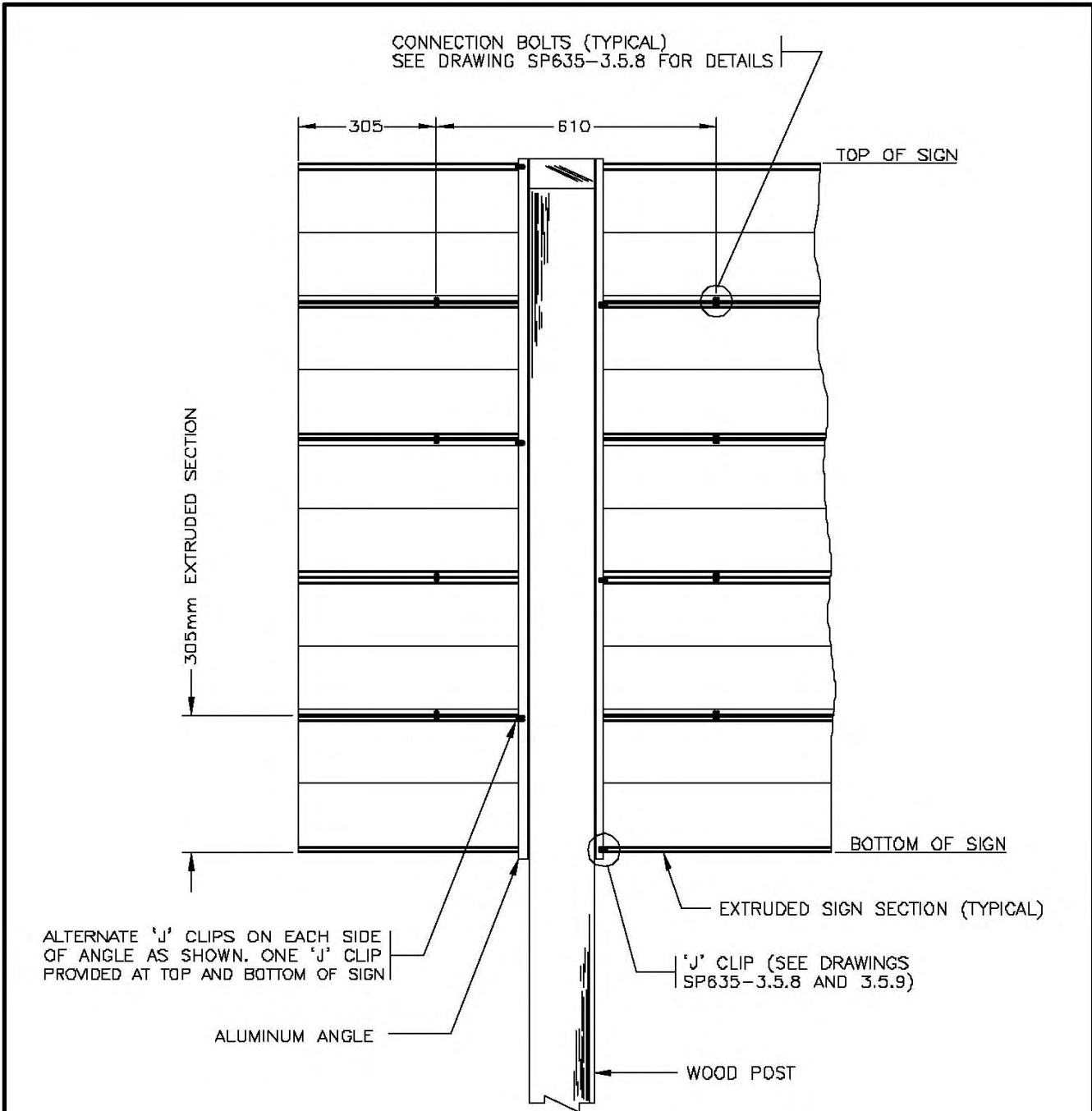

REAR VIEW OF SIGN

aaaa

SEE DRAWING SP635-3.5.6 FOR NOTES AND ADDITIONAL DETAILS.



SCALE 1:12.5

No.	Revision	Date
F		
E		
D		
C		
B		
A	END HOLE SPACING REVISED	AUG 95

EXTRUDED ALUMINUM SIGN INSTALLATION DETAILS ON WOOD POSTS		
Date	Approved	SPECIFICATION DRAWING No.
18/11/94	E.L. (Signature on File) Chief Highway Engineer	SP635-3.5.7

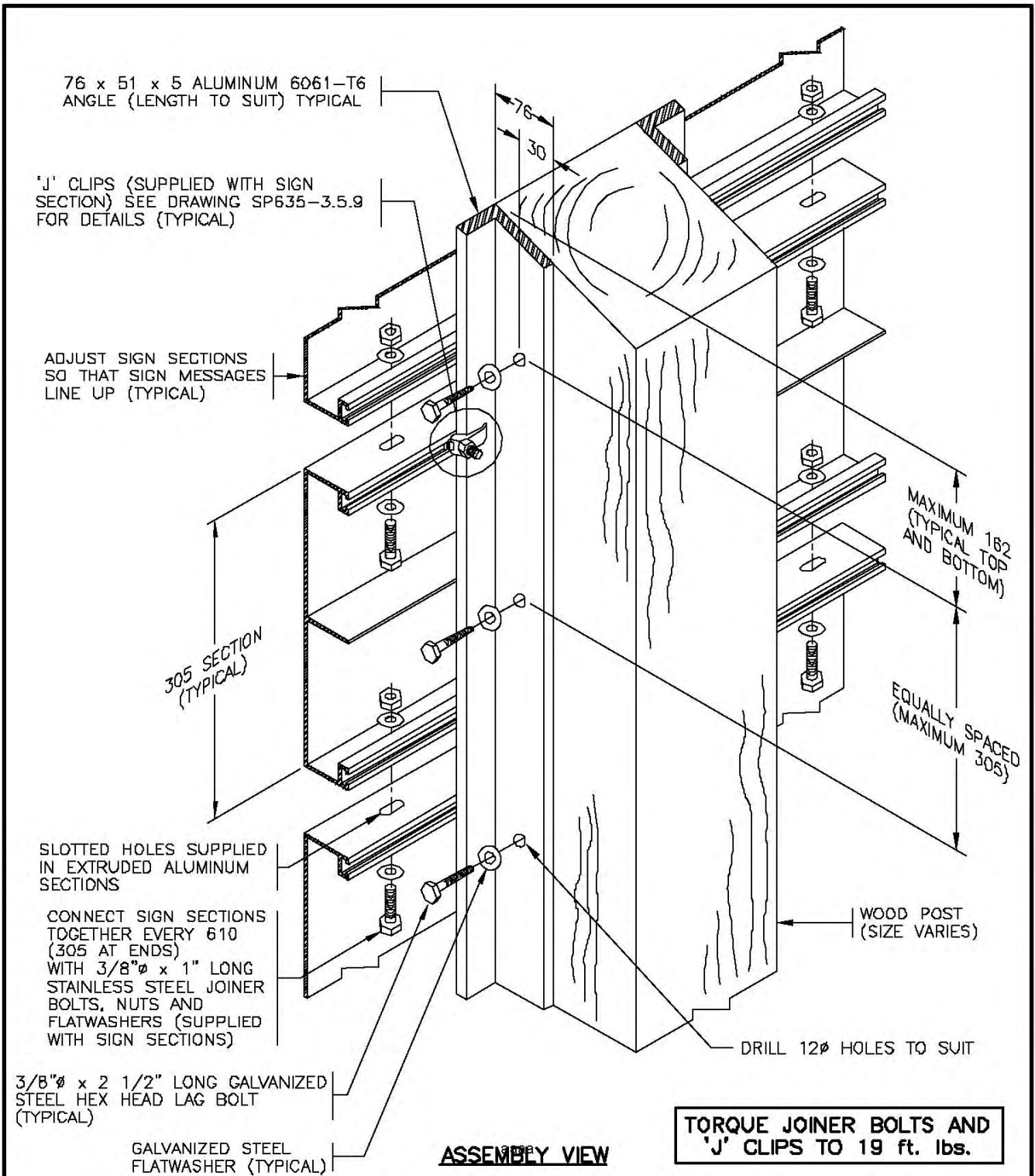

SEE DRAWING SP635-3.5.6 FOR NOTES AND ADDITIONAL DETAILS.

NOT TO SCALE



No.	Revision	Date
F		
E		
D		
C		
B		
A	END HOLE SPACING REVISED & ANGLE CUT ADDED	AUG 95

EXTRUDED ALUMINUM SIGN INSTALLATION DETAILS ON WOOD POST		
Date	Approved	SPECIFICATION DRAWING No.
18/11/94	E.L. (Signature on File) Chief Highway Engineer	SP635-3.5.8

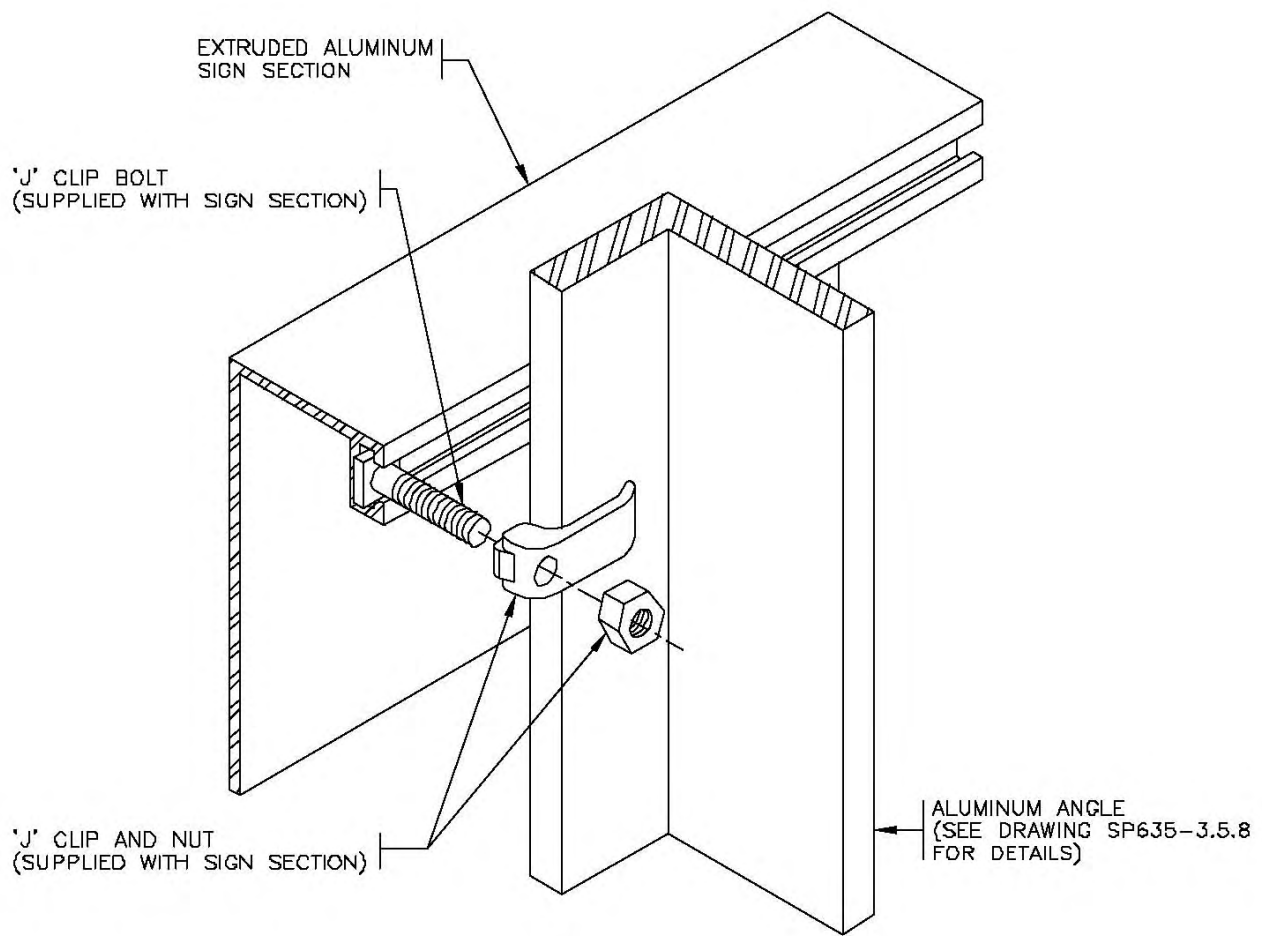

ASSEMBLY VIEW

TORQUE JOINER BOLTS AND 'J' CLIPS TO 19 ft. lbs.

aaaa

SEE DRAWING SP635-3.5.6 FOR NOTES AND ADDITIONAL DETAILS.



NOT TO SCALE

No.	Revision	Date
F		
E		
D		
C		
B		
A		

**EXTRUDED ALUMINUM SIGN INSTALLATION
DETAILS ON WOOD POST**

Date **18/11/94** Approved **E.L. (Signature on File)**
Chief Highway Engineer

SPECIFICATION
DRAWING No.
SP635-3.5.9

SIGN HEIGHT	NUMBER OF BOLTS
UP TO 750 HIGH	2
751 TO 1260 HIGH	3

SIGN(S) SHALL NOT OVERHANG ONTO ROADWAY OR SHOULDER

SIGNS SHALL NOT EXCEED 1260 IN WIDTH ON A SINGLE POST. WHERE WIDER THAN 1260 USE MULTIPLE POSTS. DIRECT BURIED SIGNS SHALL NOT EXCEED 900 IN WIDTH AND 1200 IN HEIGHT

1 1/2" (O.D.), 1 3/4" (O.D.), 2" (O.D.) OR 2 1/4" (O.D.) PERFORATED SQUARE GALVANIZED STEEL TUBING

PERFORATED SQUARE STEEL TUBING INNER SLEEVE FOR ALL POSTS EXCEPT 2 1/4" O.D. (SEE DRAWING SP635-3.6.3 FOR DETAILS)

3/8" (U.N.C.) HEX HEAD BOLT, (LENGTH TO SUIT) 2 WASHERS AND 1 NUT.

TYPE a) OR b) CONCRETE BASE (SEE DRAWING SP635-1.1.44)

TYPE 1 OR 2 CONCRETE BASE (SEE DRAWING SP635-1.1.35) SEE DETAIL THIS SHEET FOR DIRECT BURIAL AT 1000 DEPTH

REAR ELEVATION

NUT (TYPICAL)
 FLAT WASHER (TYPICAL)
 NYLON WASHER AGAINST FACE OF SIGN (TYPICAL)
 FLAT WASHER (TYPICAL)
 3/8" (U.N.C.) HEX HEAD BOLT, (LENGTH TO SUIT), TYPICAL SEE TABLE TO THE LEFT

7/16" HOLES AT 1" CENTRE TO CENTRE

PLYWOOD OR SHEET ALUMINUM SIGN
 SHEET ALUMINUM SIGNS SUPPLIED WITH PRE-DRILLED HOLES

SIDE VIEW

SIGN MOUNTING HEIGHT VARY (SEE NOTE 3)

SEE NOTES AT LEFT

EDGE OF PAVEMENT OR CURB FACE

ROADWAY

OFFSET (SEE NOTE 3)

GROUND LEVEL

1000

DIRECT BURIAL

NOTES

1. SEE STANDARD SPECIFICATIONS & SPECIAL PROVISIONS FOR ADDITIONAL INFORMATION.
2. ALL DIMENSIONS ARE IN MILLIMETRES UNLESS OTHERWISE NOTED.
3. MOUNTING HEIGHTS & OFFSETS SHALL FALL WITHIN THE RANGES NOTED IN THE MINISTRY MANUAL OF STANDARD TRAFFIC SIGNS & PAVEMENT MARKINGS.

NOT TO SCALE

REFER TO MINISTRY ELECTRICAL & TRAFFIC ENGINEERING MANUAL FOR SIGN STRUCTURE LOADING TABLE

ALL NUTS, BOLTS AND WASHERS SHALL BE STAINLESS STEEL



No.	Revision	Date
E	TRAPEZOIDAL BASE & DIRECT BURIAL DETAIL ADDED	APR 05
D	MOUNTING HEIGHTS & OFFSETS REFERED THE MINISTRY MANUAL OF STANDARD TRAFFIC SIGNS	NOV 98
C	SIGN MOUNTING HEIGHT REVISED	DEC 96
B	SIGN HEIGHT/WIDTH REVISED & OFFSET ADDED	AUG 95
A	GENERAL REVISION	AUG 94

PERFORATED SQUARE GALVANIZED STEEL SIGN POST INSTALLATION DETAIL (ONE POST)

Date: 30/09/93
 Approved: E.L. (Signature on File)
 Chief Highway Engineer

SPECIFICATION DRAWING No. SP635-3.6.1

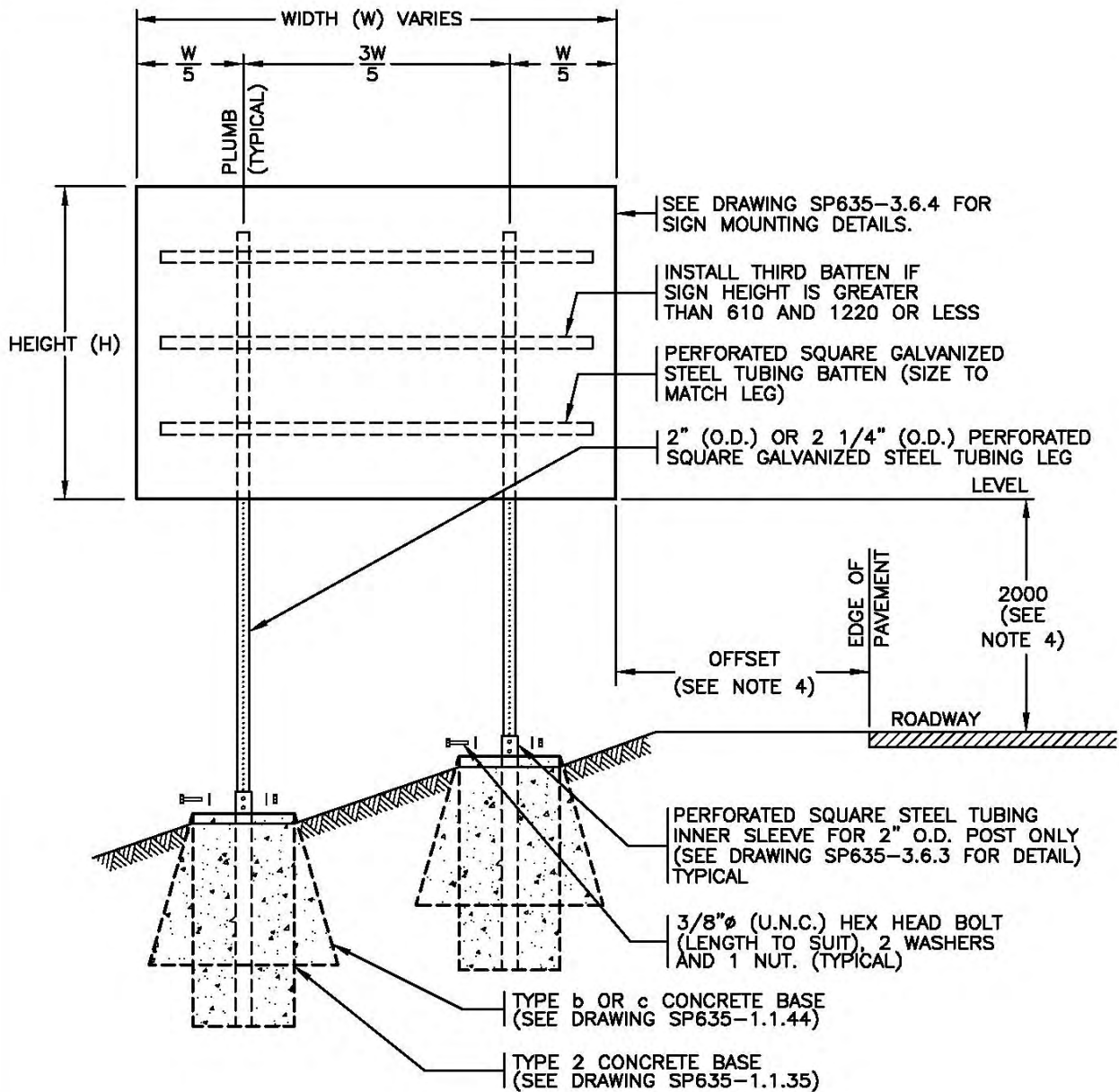

ELEVATION

NOTES

1. SEE STANDARD SPECIFICATIONS & SPECIAL PROVISIONS FOR ADDITIONAL INFORMATION.
2. ALL DIMENSIONS ARE IN MILLIMETRES UNLESS OTHERWISE NOTED.
3. ALL BOLTS, NUTS AND WASHERS SHALL BE STAINLESS STEEL.
4. MOUNTING HEIGHTS & OFFSETS SHALL FALL WITHIN THE RANGES NOTED IN THE MINISTRY MANUAL OF STANDARD TRAFFIC SIGNS & PAVEMENT MARKINGS.

REFER TO MINISTRY ELECTRICAL & TRAFFIC ENGINEERING MANUAL FOR SIGN STRUCTURE LOADING TABLE

aaaa

NOT TO SCALE



No.	Revision	Date	PERFORATED SQUARE GALVANIZED STEEL SIGN POST INSTALLATION DETAIL (TWO POST)		
E					
D	TRAPEZOIDAL BASE ADDED	APR 05			
C	MOUNTING HEIGHTS & OFFSETS REFERED THE MINISTRY MANUAL OF STANDARD TRAFFIC SIGNS	NOV 98	Date	Approved	SPECIFICATION DRAWING No.
B	BASE DWG. & LOADING TABLE REFERENCE NOTES REV'D	AUG 96	18/11/94	E.L. (Signature on File)	SP635-3.6.2
A	SIGN HEIGHT REVISED & OFFSET ADDED	AUG 95	Chief Highway Engineer		

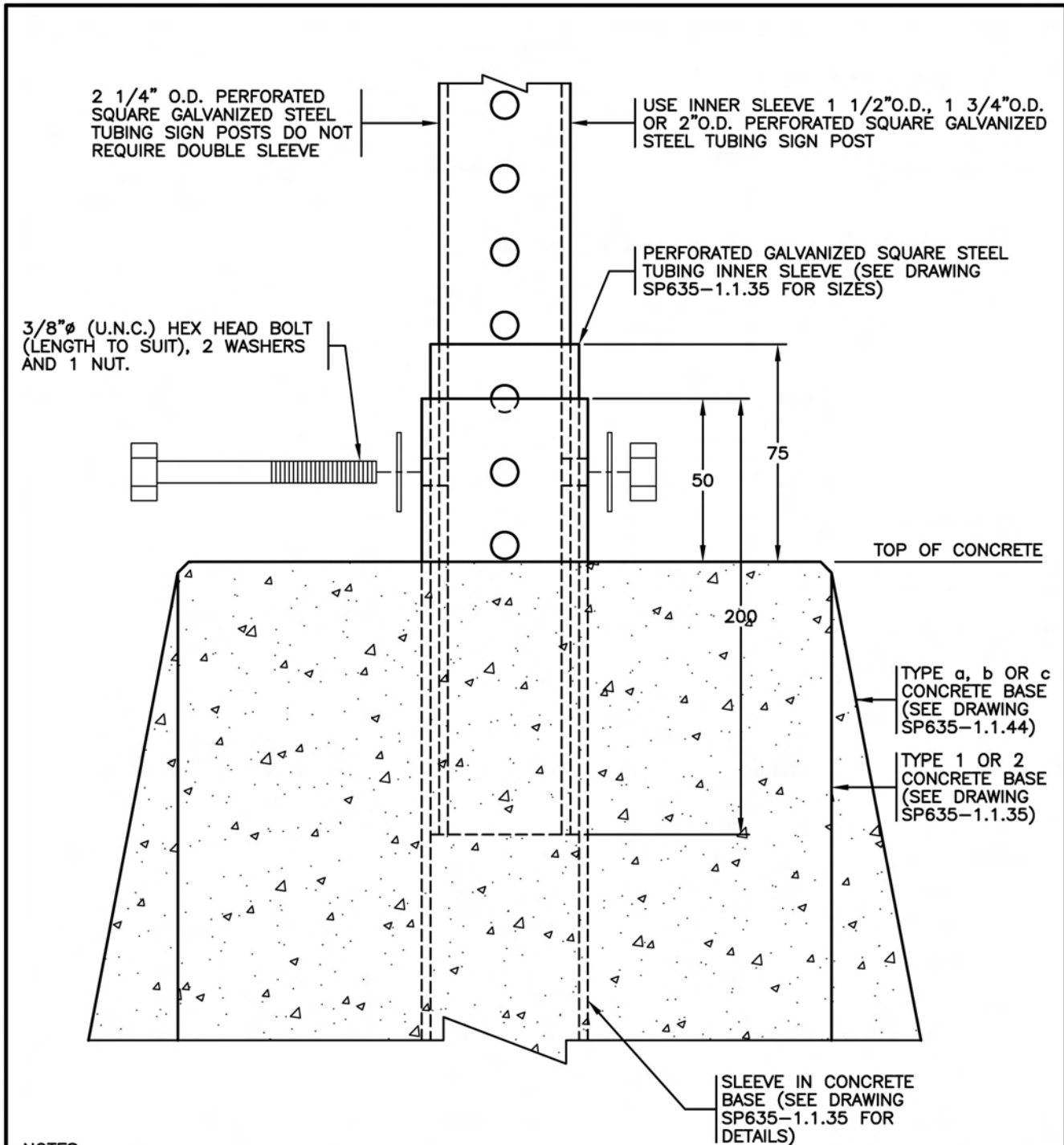

NOTES

1. SEE STANDARD SPECIFICATIONS & SPECIAL PROVISIONS FOR ADDITIONAL INFORMATION.
2. ALL DIMENSIONS ARE IN MILLIMETRES UNLESS OTHERWISE NOTED.

ALL NUTS, BOLTS AND WASHERS SHALL BE STAINLESS STEEL

NOT TO SCALE



No.	Revision	Date	PERFORATED SQUARE GALVANIZED STEEL SIGN POST INSTALLATION DETAIL		
F					
E					
D	REVISION TO SLEEVE HEIGHT	DEC 06	Date	Approved	SPECIFICATION DRAWING No. SP635-3.6.3
C	TRAPEZOIDAL BASE ADDED	APR 05	18/11/94	E.L. (Signature on File)	
B	BASE DRAWING REFERENCES REVISED	AUG 96		Chief Highway Engineer	
A	GENERAL REVISIONS	AUG 95			

BOLT SIGN AND BATTEN TO LEG WITH 3/8"φ (U.N.C.) HEX HEAD BOLT (LENGTH TO SUIT), 2 FLATWASHERS, NYLON WASHER AND 1 NUT. (TYPICAL 4 LOCATIONS)

FLATWASHER (TYPICAL)
 NYLON WASHER (TYPICAL)

PERFORATED SQUARE GALVANIZED STEEL TUBING BATTEN (SIZE TO MATCH LEG)

SHEET ALUMINUM OR PLYWOOD SIGN BOARD

INSTALL LEVEL (TYPICAL)

50

7/16"φ HOLES AT 1" CENTRE TO CENTRE (TYPICAL)

2" (O.D.) OR 2 1/4" (O.D.) PERFORATED SQUARE GALVANIZED STEEL TUBING LEG

SIDE VIEW

BOLT SIGN TO BATTENS EVERY 300± (TYPICAL)

HEIGHT (H)
 MAXIMUM 1500

1/4 (H)
 1/2 (H)
 1/4 (H)

50 (TYPICAL)

50 (TYPICAL)

INSTALL ADDITIONAL BATTEN WHEN SIGN IS OVER 610mm IN HEIGHT

BATTEN
 LEG

ELEVATION

NOTES

1. SEE STANDARD SPECIFICATIONS & SPECIAL PROVISIONS FOR ADDITIONAL INFORMATION.
2. ALL DIMENSIONS ARE IN MILLIMETRES UNLESS OTHERWISE NOTED.

ALL NUTS, BOLTS AND WASHERS SHALL BE STAINLESS STEEL



NOT TO SCALE

No.	Revision	Date	SIGN MOUNTING DETAILS ON PERFORATED SQUARE GALVANIZED STEEL TWO POST SIGN STRUCTURE		SPECIFICATION DRAWING No. SP635-3.6.4
E			Date	Approved	
D					
C					
B					
A	3rd BATTEN ADDED FOR SIGNS OVER 610mm IN HEIGHT	APR 05	18/11/94	E.L. (Signature on File) Chief Highway Engineer	

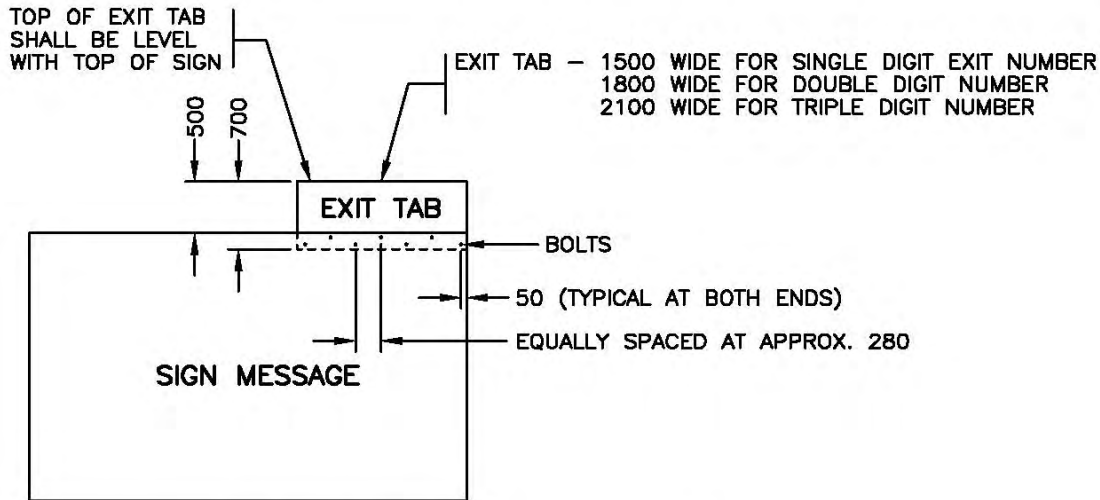

FRONT ELEVATION

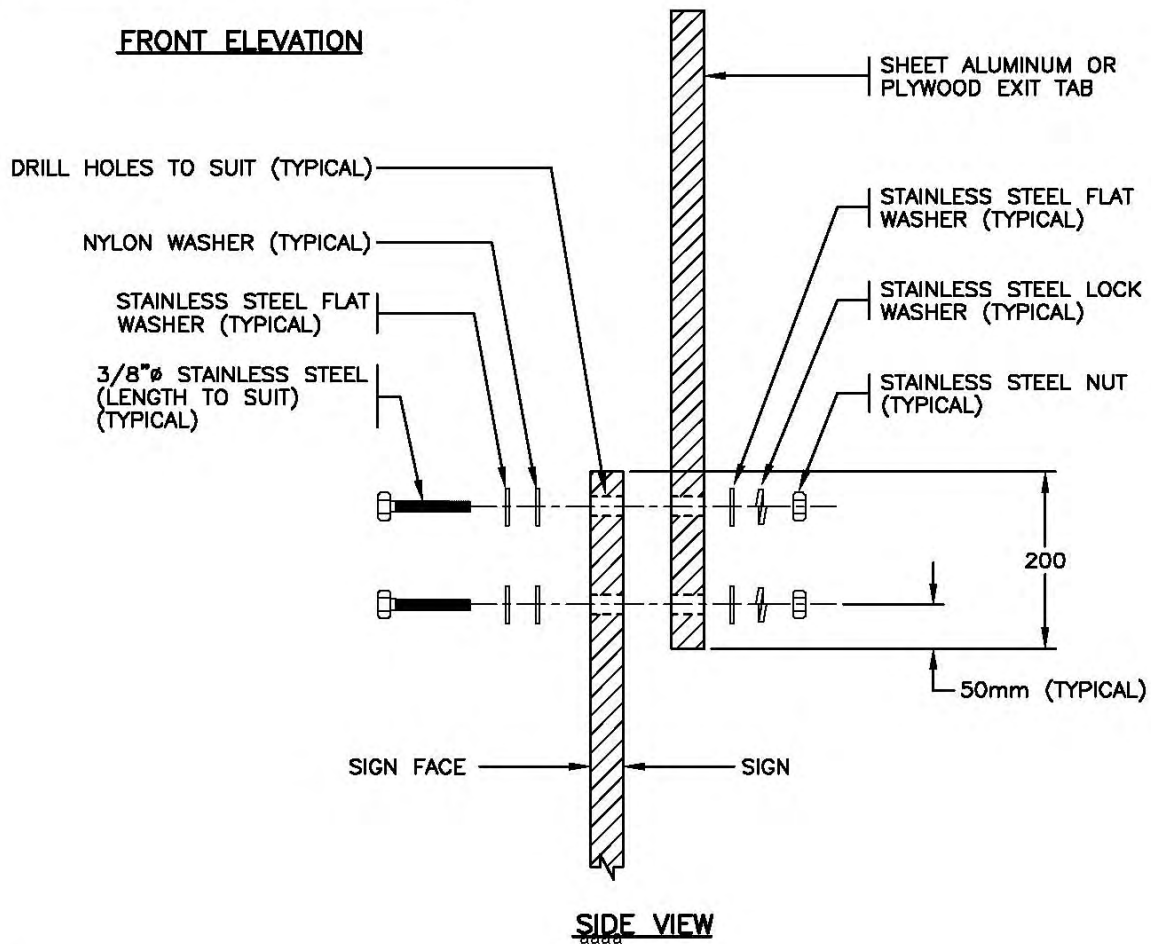

SIDE VIEW

NOTES

- 1. SEE STANDARD SPECIFICATIONS & SPECIAL PROVISIONS FOR ADDITIONAL INFORMATION.



NOT TO SCALE

No.	Revision	Date
F		
E		
D		
C		
B	GENERAL REVISION	APR 05
A	GENERAL REVISION	AUG 94

EXIT TAB MOUNTING DETAILS		
Date	Approved	SPECIFICATION DRAWING No.
30/09/93	E.L. (Signature on File) Chief Highway Engineer	SP635-3.7.1

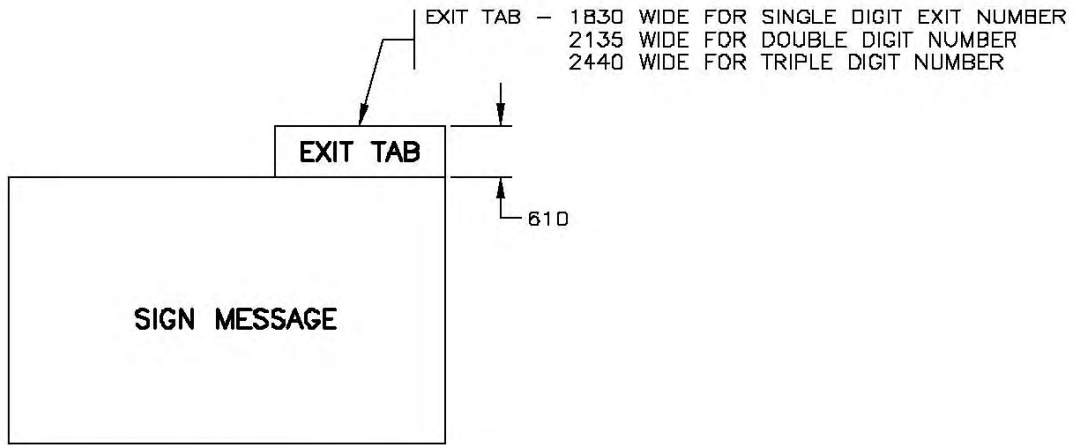

FRONT ELEVATION

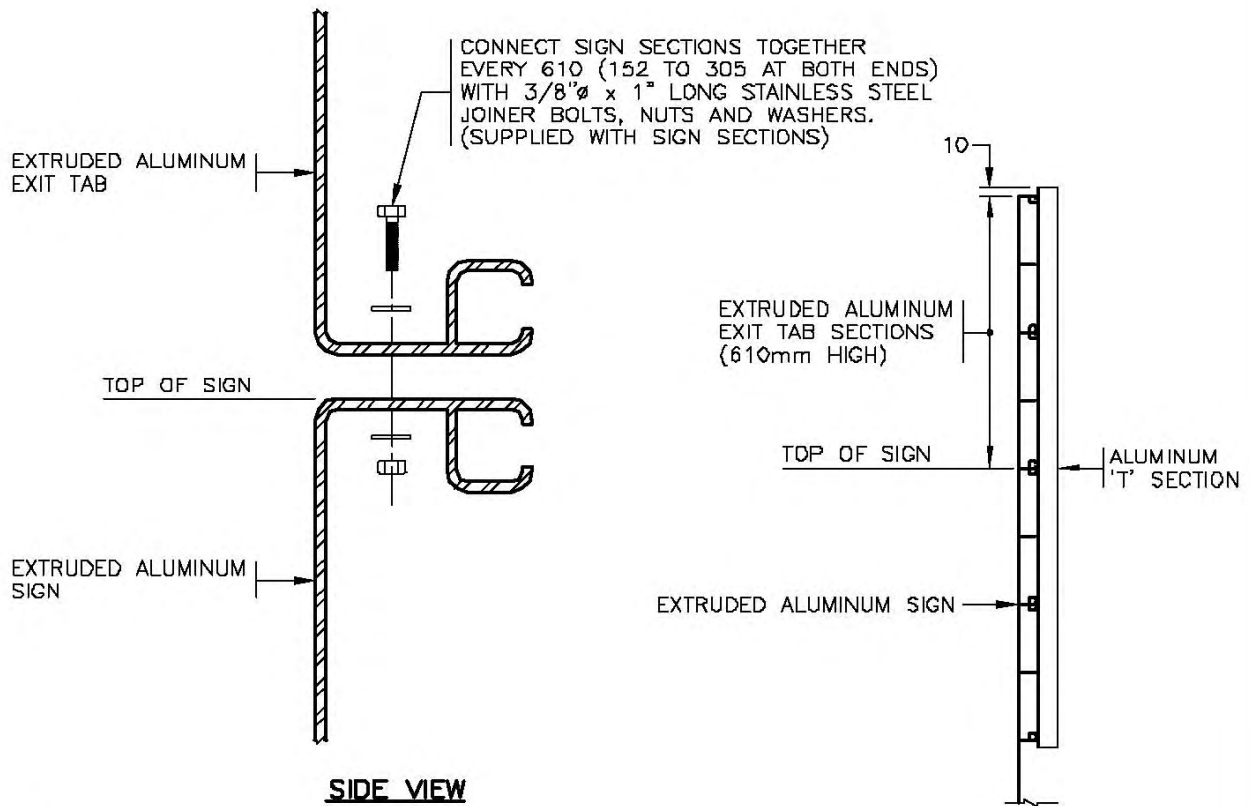

SIDE VIEW

NOTES

- SEE STANDARD SPECIFICATIONS & SPECIAL PROVISIONS ^{aaaa} FOR ADDITIONAL INFORMATION.
- ALL DIMENSIONS ARE IN MILLIMETRES UNLESS OTHERWISE NOTED.

NOT TO SCALE



No.	Revision	Date
F		
E		
D		
C		
B		
A	TAB WIDTHS & END HOLE SPACINGS REVISED	AUG 95

EXTRUDED ALUMINUM EXIT TAB MOUNTING DETAILS		
Date	Approved	SPECIFICATION DRAWING No.
18/11/94	E.L. (Signature on File) Chief Highway Engineer	SP635-3.7.2

* ADJUST SPACING TO SUIT VERTICAL SIGN SUPPORT T-SECTIONS

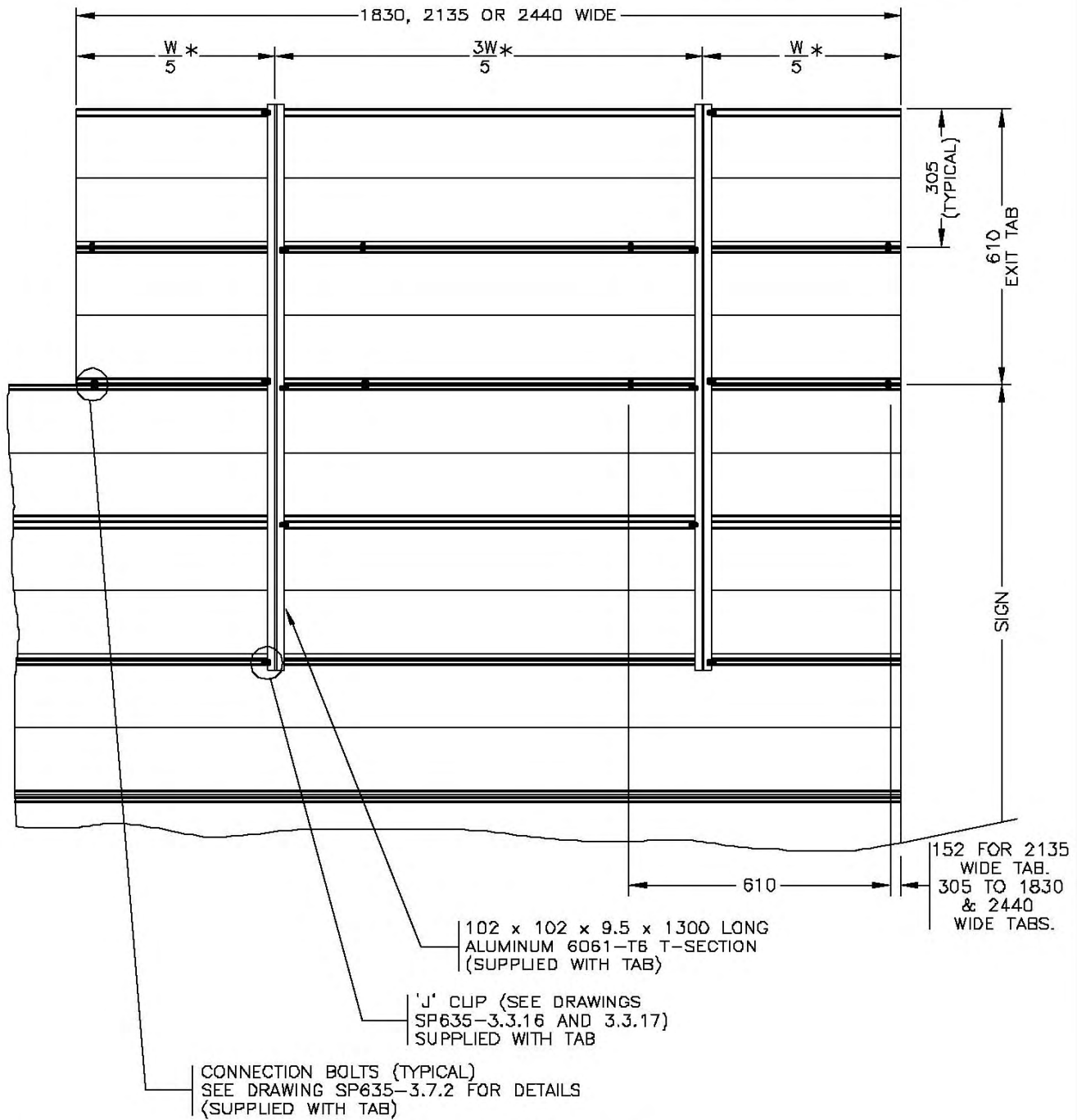

aaaa
REAR VIEW OF SIGN

SEE DRAWING SP635-3.7.2 FOR NOTES AND ADDITIONAL DETAILS.

NOT TO SCALE



No.	Revision	Date
F		
E		
D		
C		
B	DRAWING REFERENCE NUMBERS REVISED	AUG 96
A	SIGN WIDTHS & END HOLE SPACING REVISED	AUG 95

EXTRUDED ALUMINUM EXIT TAB MOUNTING DETAILS		
Date	Approved	SPECIFICATION DRAWING No.
18/11/94	E.L. (Signature on File) Chief Highway Engineer	SP635-3.7.3

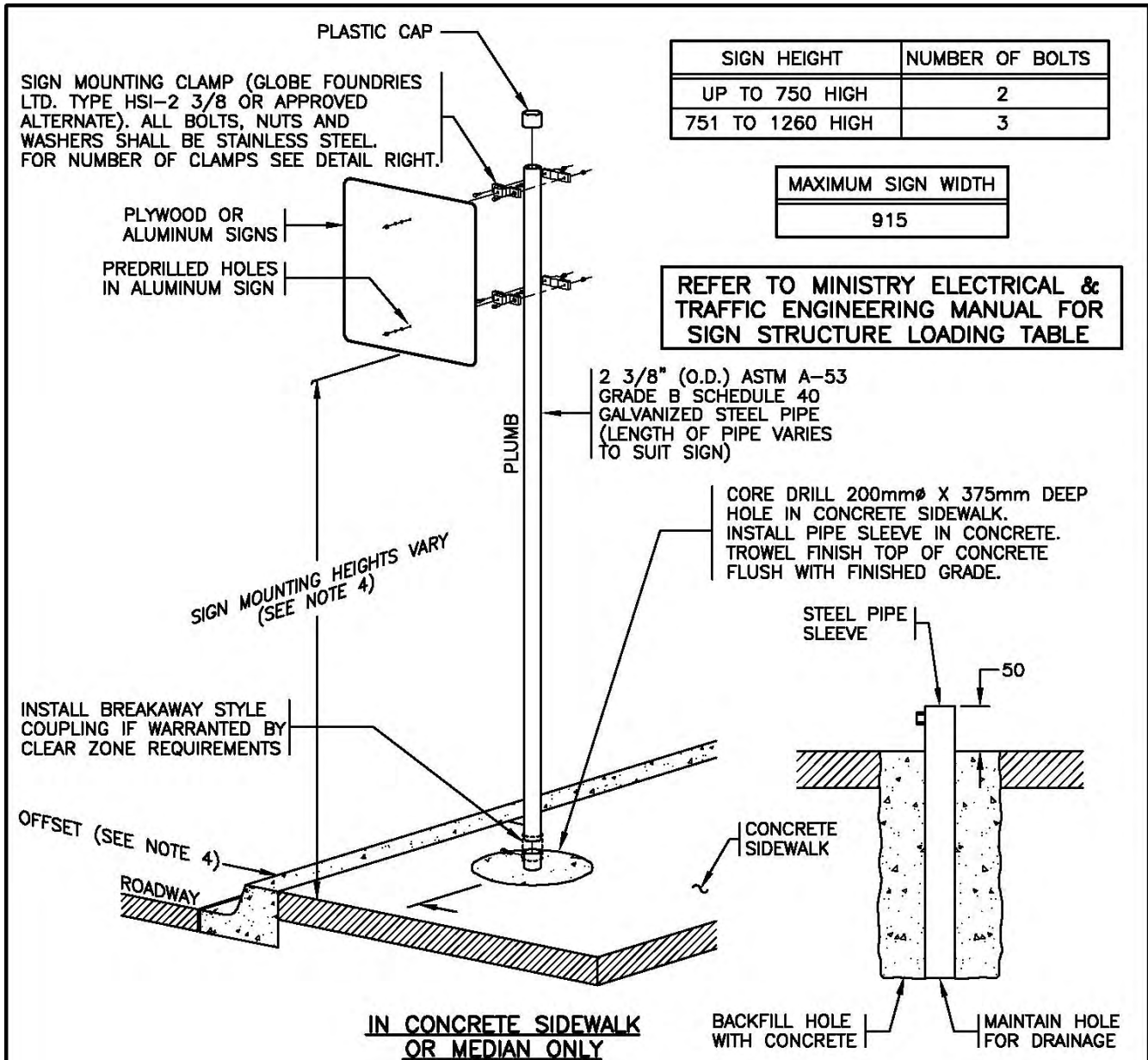

SIGN HEIGHT	NUMBER OF BOLTS
UP TO 750 HIGH	2
751 TO 1260 HIGH	3

MAXIMUM SIGN WIDTH
915

REFER TO MINISTRY ELECTRICAL & TRAFFIC ENGINEERING MANUAL FOR SIGN STRUCTURE LOADING TABLE

2 3/8" (O.D.) ASTM A-53 GRADE B SCHEDULE 40 GALVANIZED STEEL PIPE (LENGTH OF PIPE VARIES TO SUIT SIGN)

CORE DRILL 200mmØ X 375mm DEEP HOLE IN CONCRETE SIDEWALK. INSTALL PIPE SLEEVE IN CONCRETE. TROWEL FINISH TOP OF CONCRETE FLUSH WITH FINISHED GRADE.

STEEL PIPE SLEEVE

50

CONCRETE SIDEWALK

BACKFILL HOLE WITH CONCRETE | MAINTAIN HOLE FOR DRAINAGE

SLEEVE INSTALLATION DETAIL

NOTES

1. SEE STANDARD SPECIFICATIONS & SPECIAL PROVISIONS FOR ADDITIONAL INFORMATION.
2. ALL DIMENSIONS ARE IN MILLIMETRES UNLESS OTHERWISE NOTED.
3. CONCRETE SHALL HAVE A MINIMUM STRENGTH OF 30MPa PRIOR TO POST INSTALLATION.
4. MOUNTING HEIGHTS & OFFSETS SHALL FALL WITHIN THE RANGES NOTED IN THE MINISTRY MANUAL OF STANDARD TRAFFIC SIGNS & PAVEMENT MARKINGS.

WHERE INSTALLED IN GRAVEL SHOULDER OR ASPHALT ISLANDS, INSTALL POST ON CONCRETE BASE AS PER DRAWING SP635-1.1.36

NOT TO SCALE



No.	Revision	Date	ROUND STEEL SIGN POST INSTALLATION DETAILS		SPECIFICATION DRAWING No.
D	MAXIMUM SIGN WIDTH REVISED BREAKAWAY COUPLING NOTE ADDED	APR 05	Date	Approved	SP635-3.8.1
C	MOUNTING HEIGHTS & OFFSETS REFERED THE MINISTRY MANUAL OF STANDARD TRAFFIC SIGNS	NOV 98	30/09/93	E.L. (Signature on File)	
B	SIGN MOUNTING HEIGHT REVISED	DEC 96	Chief Highway Engineer		
A	GENERAL REVISION	AUG 94			

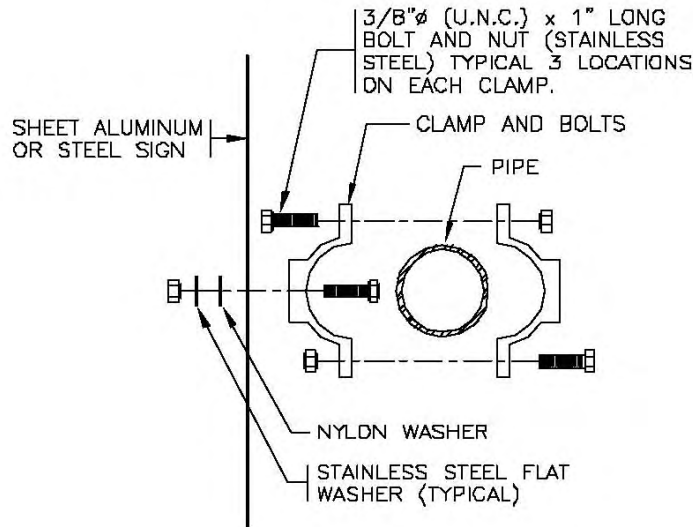

SIGN MOUNTING DETAILS

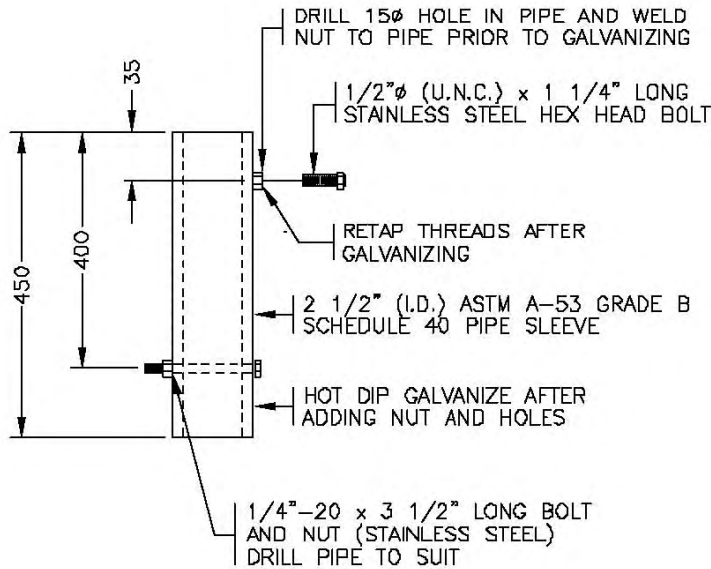

GALVANIZED PIPE SLEEVE DETAIL

NOTES

- 1. SEE STANDARD SPECIFICATIONS & SPECIAL PROVISIONS FOR ADDITIONAL INFORMATION.
- 2. ALL DIMENSIONS ARE IN MILLIMETRES UNLESS OTHERWISE NOTED.

NOT TO SCALE

aaaa



No.	Revision	Date
F		
E		
D		
C		
B		
A		

ROUND STEEL SIGN POST INSTALLATION DETAILS		
Date	Approved	SPECIFICATION DRAWING No.
18/11/94	E.L. (Signature on File) Chief Highway Engineer	SP635-3.8.2

SIGN MOUNTING CLAMP (GLOBE FOUNDRIES LTD. TYPE HSI-2 3/8 OR APPROVED ALTERNATE). ALL BOLTS, NUTS AND WASHERS SHALL BE STAINLESS STEEL. FOR NUMBER OF CLAMPS SEE DETAIL BELOW.

SHEET ALUMINUM OR PLYWOOD SIGN
 PREDRILLED HOLES IN ALUMINUM SIGN

PLASTIC CAP

3/8"ø (U.N.C.) x 1" LONG BOLT AND NUT (STAINLESS STEEL) TYPICAL 3 LOCATIONS ON EACH CLAMP

CLAMP AND BOLTS

PIPE

NYLON WASHER

SHEET ALUMINUM SIGN

STAINLESS STEEL FLAT WASHER (TYPICAL)

SIGN MOUNTING DETAILS

2 3/8" (O.D.) ASTM A-53 GRADE B SCHEDULE 40 GALVANIZED STEEL PIPE (LENGTH VARIES TO SUIT SIGN & MOUNTING HEIGHT)

LOCKING BOLT (SUPPLIED WITH BARRIER STAND)

BARRIER SIGN STAND (SN2180) FOR CONCRETE MEDIAN BARRIER (25kg)
 BARRIER SIGN STAND (SN2181) FOR CONCRETE ROADSIDE BARRIER (21kg)
 (SEE RECOGNIZED PRODUCT BOOK)

SLOTTED HOLES

PLASTIC CAP (SUPPLIED WITH BARRIER STAND)

300

3/4"ø (U.N.C.) x 400mm LONG GALVANIZED READY ROD AND 2 GALVANIZED NUTS. (SUPPLIED WITH BARRIER STAND)

CUT ROD FLUSH WITH NUTS

CONCRETE MEDIAN BARRIER (810 HIGH) OR CONCRETE ROADSIDE BARRIER (690 HIGH)

SIGN MOUNTING HEIGHTS VARY (SEE NOTE 3)

REFER TO MINISTRY ELECTRICAL & TRAFFIC ENGINEERING MANUAL FOR SIGN STRUCTURE LOADING TABLE

SIGN HEIGHT	NUMBER OF BOLTS
UP TO 750 HIGH	2
751 TO 1260 HIGH	3

NOTES

- SEE STANDARD SPECIFICATIONS & SPECIAL PROVISIONS FOR ADDITIONAL INFORMATION.
- ALL DIMENSIONS ARE IN MILLIMETRES UNLESS OTHERWISE NOTED.

aaaa

- MOUNTING HEIGHTS & OFFSETS SHALL FALL WITHIN THE RANGES NOTED IN THE MINISTRY MANUAL OF STANDARD TRAFFIC SIGNS & PAVEMENT MARKINGS.

NOT TO SCALE



No.	Revision	Date
E	REFER TO RECOGNIZED PRODUCT BOOK	APR 05
D	MOUNTING HEIGHTS & OFFSETS REFERED THE MINISTRY MANUAL OF STANDARD TRAFFIC SIGNS	NOV 98
C	DWG. No. & MOUNTING HEIGHTS REV'D	DEC 96
B	SIGN MATERIAL & SIGN WIDTH REVISED	AUG 95
A	GENERAL REVISION	AUG 94

ROUND STEEL SIGN POST ON BARRIER SIGN STAND INSTALLATION DETAILS

Date: **30/09/93**
 Approved: **E.L. (Signature on File)**
 Chief Highway Engineer

SPECIFICATION DRAWING No. **SP635-3.8.3**

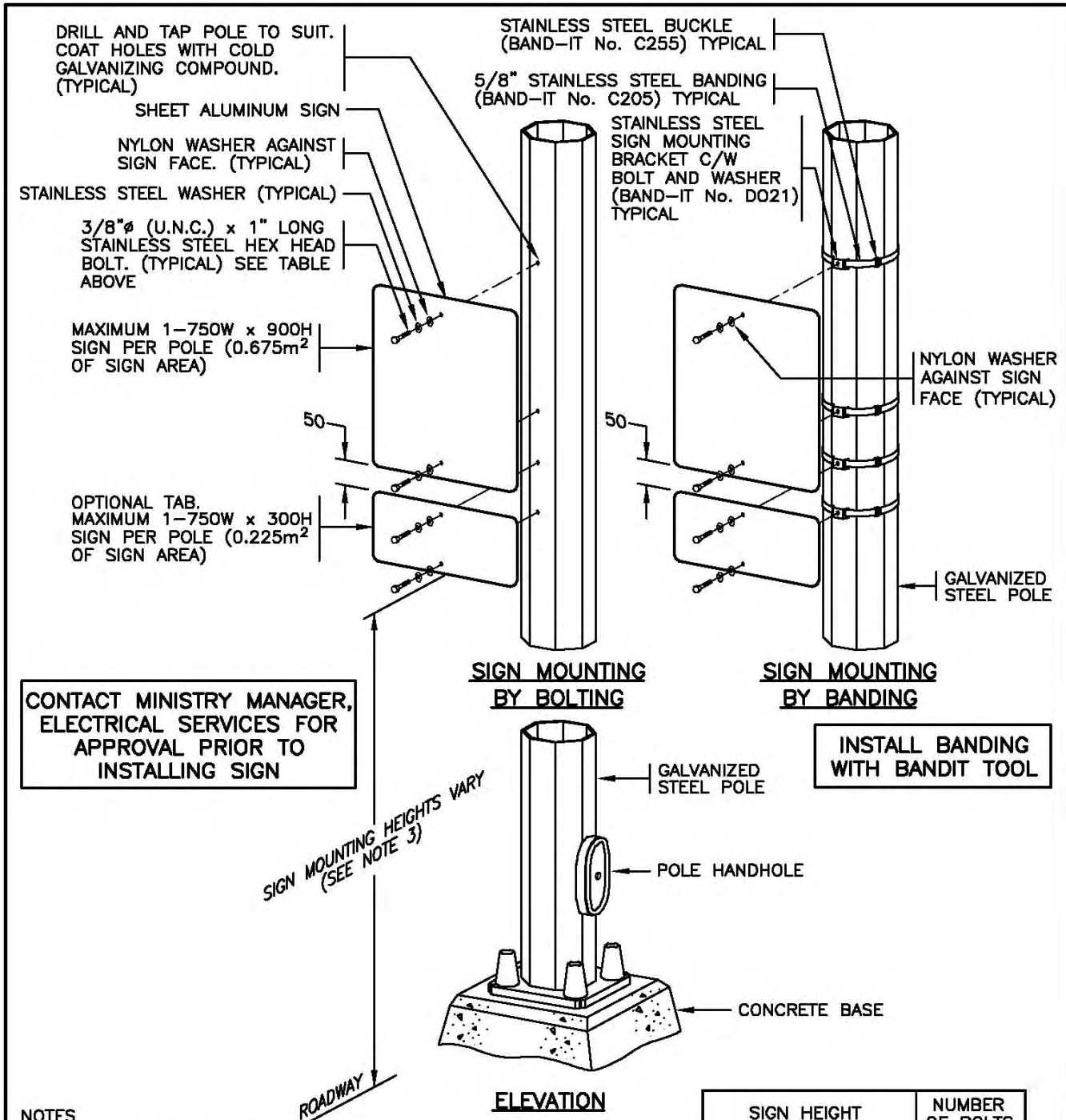

NOTES

- SEE STANDARD SPECIFICATIONS & SPECIAL PROVISIONS FOR ADDITIONAL INFORMATION.
- ALL DIMENSIONS ARE IN MILLIMETRES UNLESS OTHERWISE NOTED.
- MOUNTING HEIGHTS & OFFSETS SHALL FALL WITHIN THE RANGES NOTED IN THE MINISTRY MANUAL OF STANDARD TRAFFIC SIGNS & PAVEMENT MARKINGS.

NOT TO SCALE



No.	Revision	Date
G	MINISTRY APPROVAL NOTE REVISED	APR 05
F	MINISTRY APPROVAL NOTE ADDED	NOV 01
E	BANDING SIGN MOUNTING ADDED	SEPT 00
D	MOUNTING HEIGHTS & OFFSETS REFERED THE MINISTRY MANUAL OF STANDARD TRAFFIC SIGNS	NOV 98
C	SIGN MOUNTING HEIGHT REVISED	DEC 96

SIGN INSTALLATION ON THE SIDE OF POLES		
Date	Approved	SPECIFICATION DRAWING No.
30/09/93	E.L. (Signature on File) Chief Highway Engineer	SP635-3.9.1

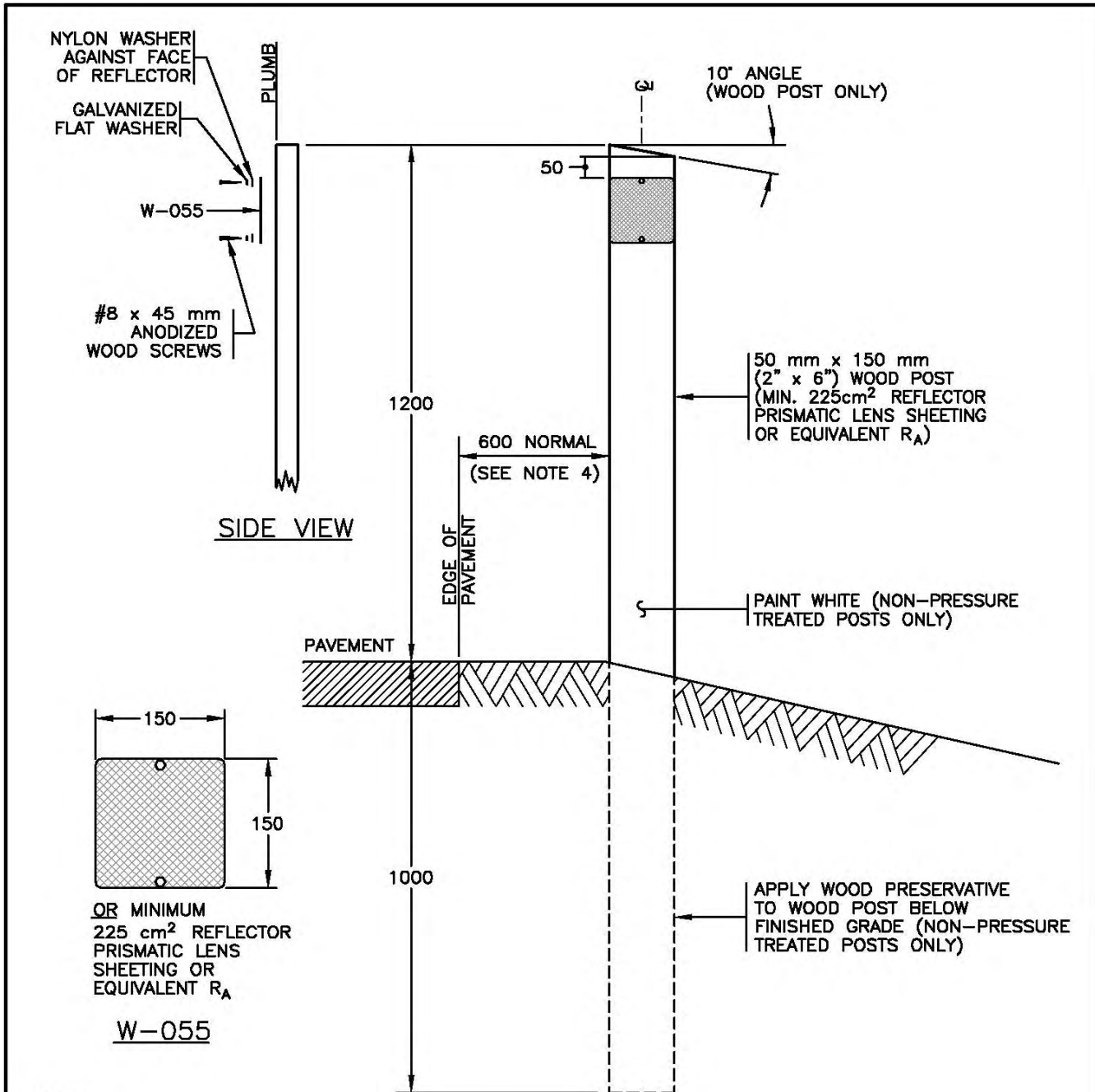

NOTES

1. SEE THE MINISTRY'S "STANDARD TRAFFIC SIGNS AND PAVEMENT MARKING MANUAL" TABLE 7.4 FOR DELINEATOR SPACING ON HORIZONTAL CURVES.
2. SEE STANDARD SPECIFICATIONS & SPECIAL PROVISIONS FOR ADDITIONAL INFORMATION. aaaa
3. ALL DIMENSIONS ARE IN MILLIMETRES UNLESS OTHERWISE NOTED.
4. POST PLACED A MINIMUM OF 1.0 m TO A MAXIMUM OF 3.6 m FROM EDGE OF TRAVELLED LANE.



NOT TO SCALE

No.	Revision	Date	WOOD DELINEATOR POST INSTALLATION DETAILS		
F					
E	PRESSURE TREATED POSTS ADDED	APR 05			
D	SIZE & NUMBER OF REFLECTORS	NOV 01	Date	Approved	SPECIFICATION DRAWING No.
C	SIGN NUMBER REVISED	AUG 96	30/09/93	E.L. (Signature on File)	SP635-3.10.1
B	OFFSETS ADDED	AUG 95	Chief Highway Engineer		
A	GENERAL REVISION	AUG 94			

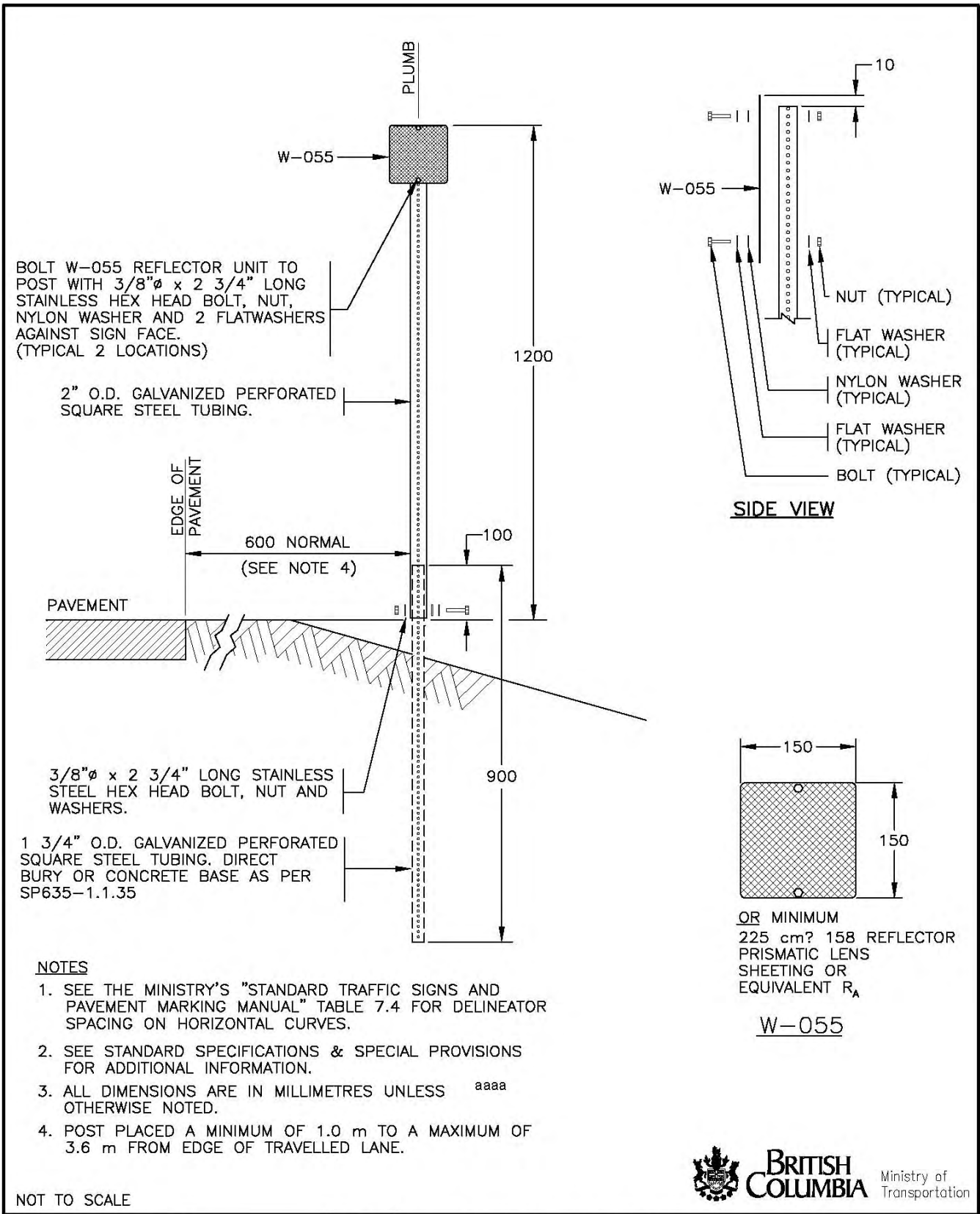

No.	Revision	Date
F		
E	GENERAL REVISION	APR 05
D	SIZE & NUMBER OF REFLECTORS	NOV 01
C	OFFSET & POST LENGTHS REVISED	OCT 99
B	W-055 SIGN REFERENCES REVISED	AUG 96
A	OFFSETS ADDED	AUG 95

PERFORATED SQUARE STEEL TUBING DELINEATOR POST INSTALLATION DETAILS		Date	Approved	SPECIFICATION DRAWING No.
		18/11/94	E.L. (Signature on File) Chief Highway Engineer	SP635-3.10.2

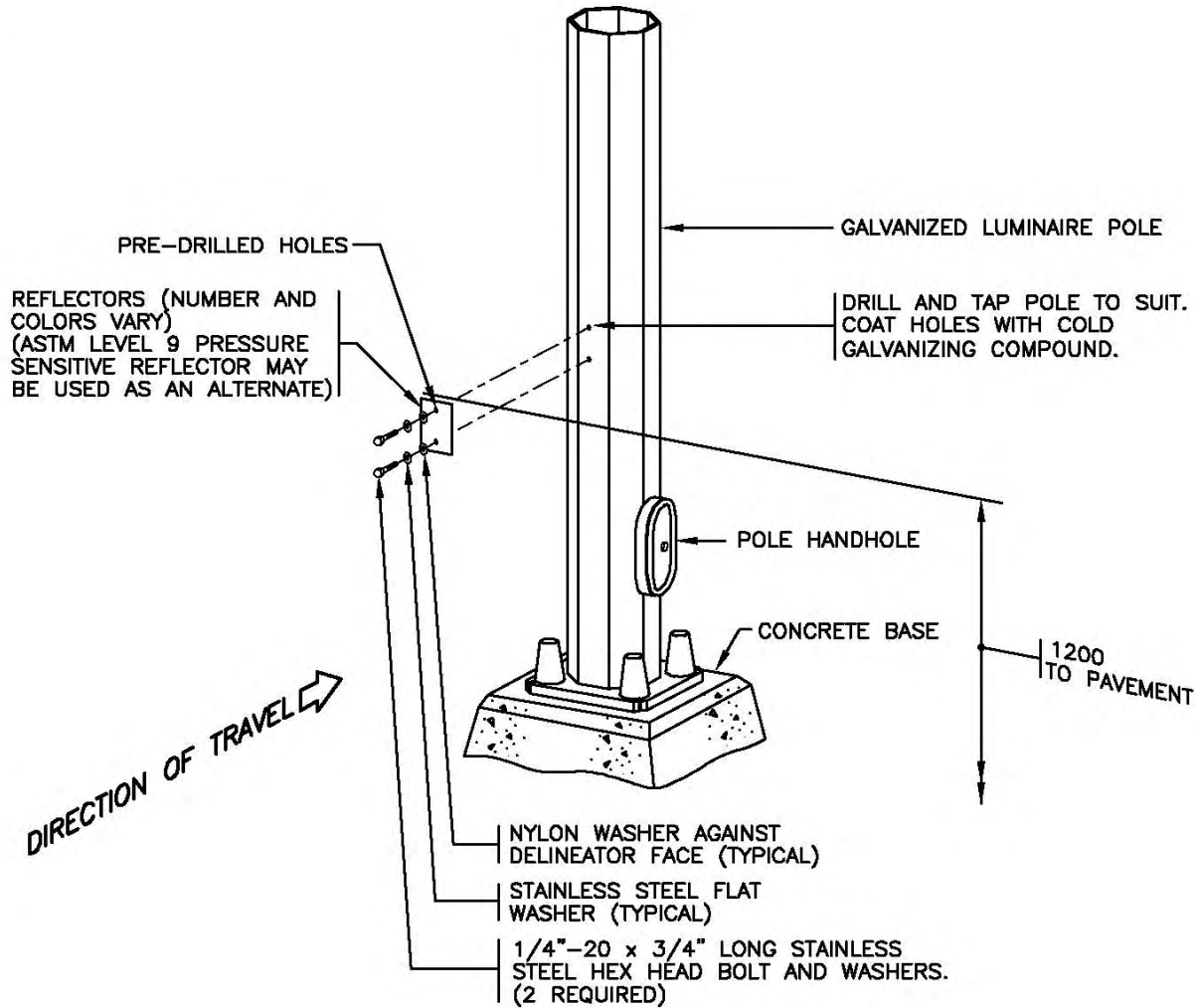

ASSEMBLY DETAIL

NOTES

1. NUMBER, COLOUR, SIZE AND SHAPE OF REFLECTORS VARIES. SEE THE MINISTRY'S PAVEMENT MARKING MANUAL (JUNE 94 ISSUE) FOR MORE INFORMATION.
2. DELINEATOR MANUFACTURER MUST MEET MINISTRY APPROVAL.
3. SEE STANDARD SPECIFICATIONS & SPECIAL PROVISIONS FOR ADDITIONAL INFORMATION.
4. ALL DIMENSIONS ARE IN MILLIMETRES UNLESS *aaaa* OTHERWISE NOTED.
5. INSTALL REFLECTOR ON LUMINAIRE POLE (OR SIMILAR) IF DELINEATOR TO BE POSITIONED WITHIN 5m OF POLE (OR SIMILAR).



NOT TO SCALE

No.	Revision	Date	PLASTIC DELINEATOR INSTALLATION ON POLE		SPECIFICATION DRAWING No.
F			Date	Approved	SP635-3.10.3
E			30/09/93	E.L. (Signature on File)	
D			Chief Highway Engineer		
C					
B	NOTE 5 ADDED	APR 05			
A	GENERAL REVISION	AUG 94			

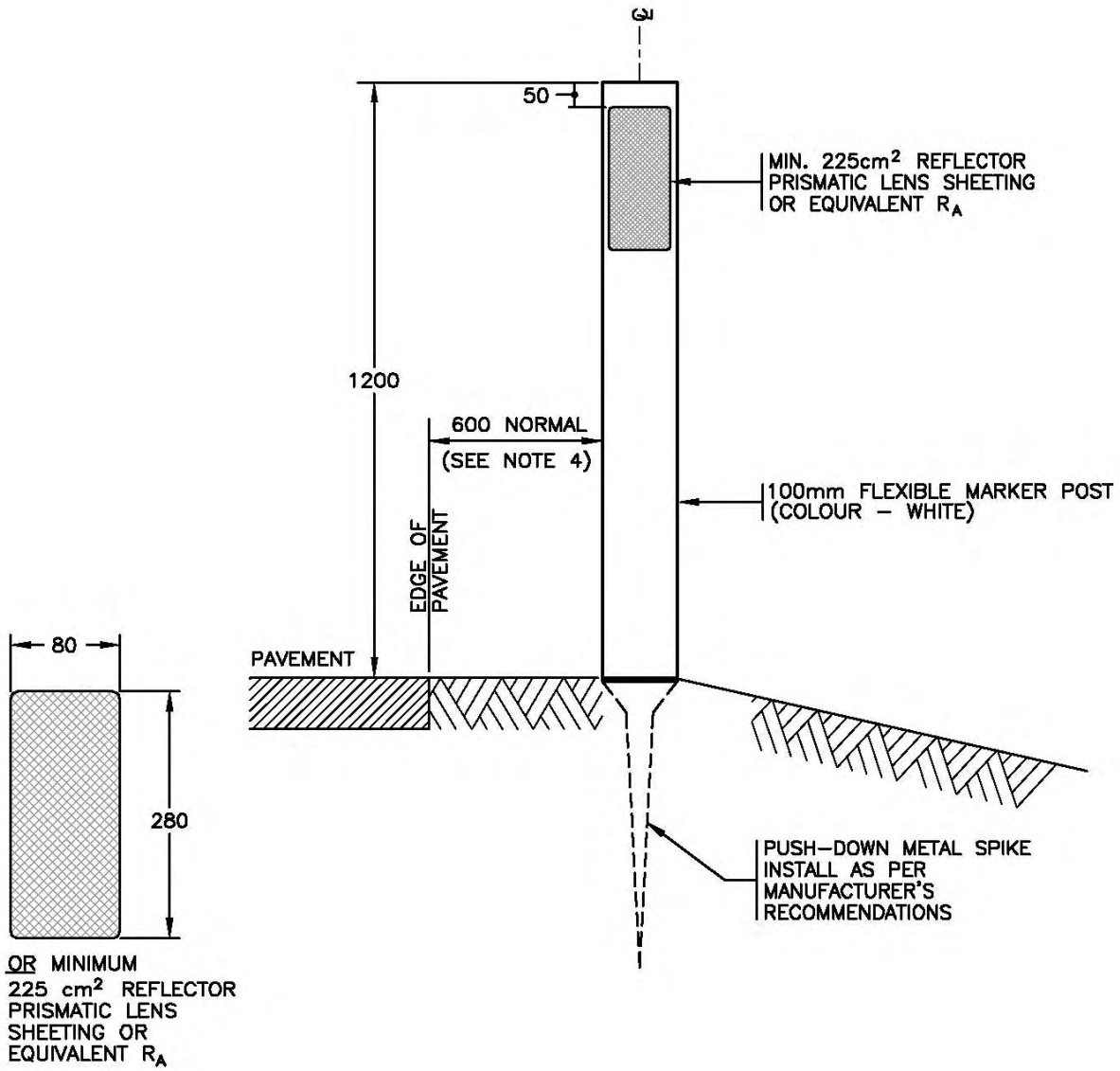

W-055

NOTES

1. SEE THE MINISTRY'S "STANDARD TRAFFIC SIGNS AND PAVEMENT MARKING MANUAL" TABLE 7.4 FOR DELINEATOR SPACING ON HORIZONTAL CURVES.
2. SEE STANDARD SPECIFICATIONS & SPECIAL PROVISIONS FOR ADDITIONAL INFORMATION. aaaa
3. ALL DIMENSIONS ARE IN MILLIMETRES UNLESS OTHERWISE NOTED.
4. POST PLACED A MINIMUM OF 1.0 m TO A MAXIMUM OF 3.6 m FROM EDGE OF TRAVELLED LANE.



NOT TO SCALE

No.	Revision	Date	FLEXIBLE DELINEATOR POST INSTALLATION DETAILS	
F			Date	Approved
E			20/04/05	D.N. (Signature on File)
D				Chief Highway Engineer
C				SPECIFICATION DRAWING No.
B				SP635-3.10.4
A				

SECTION 700

WILDLIFE EXCLUSION FENCING

DESCRIPTION

700.01 Scope – This Section covers the construction of wildlife exclusion fencing with galvanized wire mesh, pressure treated wood poles and/or galvanized metal posts, one-way gates, lockable human access gates and double swing gates and, with reference to Drawings of the SP700 series, is intended to specify acceptable standards and some optional features as may be required by the Special Provisions.

Alternative construction may be called for by the Drawings, the Special Provisions or instructions of the Ministry Representative, and alternative methods may be acceptable upon submission to the Ministry Representative.

MATERIALS

700.10 Post Type – Posts may be wood or steel, except that:

Steel posts shall be used:

- where it is not possible to attain the required embedment for wood posts, such as where bedrock or boulders obstruct the post hole;
- on ground slopes exceeding 1.5 horizontal to 1 vertical (34°);
- in wetlands, in areas frequently under water, or in areas of soft organic soils; and
- where it is determined that wood posts are unsuitable for the existing ground conditions, topography or other environmental factors.

700.11 Wood Posts – Wood posts shall be straight peeled jack pine or lodgepole pine 4300 mm long with a minimum tip diameter of 150 mm and a maximum butt diameter of 200 mm. The bottoms of the wood posts must be tapered to a rounded end for driveability. Round wood posts shall be treated in accordance with CSA O80-97, and in particular, CSA O80.5-97 Preservative Treatment of Posts by Pressure Processes. Sawn timber posts and members shall be treated for ground contact in accordance with CSA O80-97, and in particular, CSA O80.2-97 Preservative Treatment of Lumber, Timber, Bridge Ties and Mine Ties by Pressure Processes.

700.12 Preservative Treatment for Protecting Field Cut Wood and Bolt Holes – Field cuts and bolt holes shall be protected in accordance with AWP Standard M4. The colour of the preservative treatment used for

protecting field cut wood and bolt holes shall match the original preservative treatment colour, where possible.

700.13 Steel Posts – Where steel posts are located in wetlands, in areas frequently under water, or in areas of soft organic soils, they shall conform to ASTM-A-53-89a, Schedule 80, or equivalent; hot dipped galvanized to the requirements of CAN/CSA G164M Table 1. Otherwise, steel posts shall conform to ASTM-A-53-89a, Schedule 40, or equivalent; hot dipped galvanized to the requirements of CAN/CSA G164M Table 1.

The steel posts will not have an outside diameter less than 73 mm. The length of steel posts may vary between 3560 mm and 4500 mm according to installation conditions as shown on the Drawings.

Upon approval by the Ministry Representative, short steel posts may be lengthened, by a maximum of 1000 mm, by a welded extension. All welds shall be inspected by the Ministry Representative. Welds will be ground as necessary to achieve a smooth, bare metal surface and immediately covered with two coats of zinc rich coating as per SS 700.14

700.14 Touch-up Treatment for Galvanized Metal Surfaces – Touch-up treatment for damaged galvanizing of steel posts and braces shall be two coats of an organic, zinc rich paint on a thoroughly cleaned surface.

700.15 Fabric – The fence fabric will be 2.44 m (8 ft) high with 150 mm (6 in) horizontal and graduated vertical spacing, 12.5 gauge high tensile wire with a twisted friction type joint at each horizontal/vertical contact point. The fence fabric will have a minimum of 20 horizontal wires, with graduated vertical spacing ranging from 7.62 cm (3 inches) at the bottom to 17.78 cm (7 inches) at the top. The fence material will be galvanized to a retention of not less than Class 3 coating, 240 g/m². The horizontal wires will have a minimum tensile strength of 1234 MPa (179 ksi).

700.15.01 Fence Fabric in Confined Locations – Where space limitations do not permit the handling of the full 2.44 m (8 ft) section of fence, it will be permissible, where approved by the Ministry Representative, to use two, 1.22 m (4 ft) sections of fencing. These sections will be connected by galvanized steel compression hog rings every 150 mm or joined longitudinally with a continuous 3 mm (11 gauge) galvanized wire woven through the mesh and wrapped every 150 mm.

SECTION 700

WILDLIFE EXCLUSION FENCING

700.16 One-Way Gates – Gates shown on the Drawings shall be of the prefabricated type indicated on Drawings SP700-12.1 to SP700-12.6 and as specified in SS 316.11 and/or in the Special Provisions. The one-way gates must be test assembled in shop, adjusted and lubricated to swing freely without binding, and quietly shut from any position.

700.16.01 One-Way Gate Tines – Tines shall be fabricated from AISI 4140 high tensile steel to avoid animals or people bending them. Subsequent to cold-bending the tines, and prior to hot-dipped galvanizing, the material shall be heat treated and stress relieved to achieve a Rockwell C Hardness (HRC) value of 30-35. The vertical gap between sections of tines must not exceed 200 mm. The horizontal gap between the left and right sections of tines of the one-way gates must not exceed 100 mm.

All metal in one-way gates must be galvanized. Acid bath treatment of the tines prior to galvanization shall be controlled to minimize potential weakening of welds.

700.17 Lockable Human Access Gates – Gates shown on the Drawings shall be of the prefabricated type indicated on Drawings SP700-14.1 to SP700-14.2. The lockable human access gates must be adjusted and lubricated to swing and shut freely without binding in the field. Lock assemblies must be adjusted to work in the field.

700.18 Double Swing Gates – Gates shown on the Drawings shall be of the prefabricated type indicated on Drawings SP700-13.1 to SP700-13.2. The human access gates must be adjusted and lubricated to swing and shut freely without binding in the field. Lock assemblies must be adjusted to work in the field.

CONSTRUCTION

700.20 Provision of Fencing – Fencing shall be carried out at the locations and as shown on the Drawings with the materials to the height, spacing and with accessories all in accordance with the details indicated on the Drawings, Standard Specifications, and Special Provisions or to the direction of the Ministry Representative.

All material shall be supplied by the Contractor, except where supply in whole or in part by the Ministry, f.o.b. the Contractor's job site yard or Ministry's yard, is specified in the Special Provisions.

Construction shall be carried out with all labour, tools, equipment and incidentals supplied by the Contractor, as necessary, to complete all fencing work in accordance with good work practice.

700.21 Clearing & Grading – Prior to commencing fencing work, both sides of the fence line must be free of all clearing and grubbing debris. All trees, other than those required by the Ministry Representative to remain, and all brush and other obstacles which interfere with the construction and maintenance of fencing and not removed by the normal clearing operations, must be removed.

The cleared and graded area must be a minimum of 3 m wide on each side of the fence to permit access for fence repairs and maintenance, unless a lesser width is permitted by the Ministry Representative.

The groundline for the fence should be smooth and continuous for a minimum of 1 m on both sides of the fence. Minor ground undulations shall be corrected to obtain a smooth uniform grade, but appreciable grade depressions may be backfilled only with the permission of the Ministry Representative.

The site shall be left in a smooth and tidy condition.

700.22 Setting Out and Connections to Existing Fences – Fence line, as shown on the Drawings, generally will be located a minimum of 3 m from the right-of-way boundary, unless a lesser distance is permitted by the Ministry Representative.

In areas of heavy snow, where the 10 year average total annual snowfall is greater than 2 m, as identified in Special Provisions, the fence line must be offset a minimum of 4 m from the edge of the highway shoulder to reduce damage from snowplows. Otherwise, the fence line must be offset a minimum of 3 m from the edge of the highway shoulder.

Post installation in fill material or minimum overburden shall be carried out according to the Ministry Representative's directions. Where it is not possible to drive or set wood posts to proper depth or to relocate same along the fence line, steel fence posts as specified or, where permitted, multiple wood post and brace assemblies shall be substituted.

Existing fences shall be connected to new fences with posts and braces for tensioning fencing wire in every direction in accordance with the SP700 series of Drawings.

700.23 Post Spacing – Unless specified otherwise in Special Provisions, line posts shall be spaced 5 m apart measured horizontally. It will be permissible to move a post up to 0.3 m ahead or back along the fence line to avoid an obstruction preventing advancement of the post hole, provided that the average spacing does not exceed 5 m.

SECTION 700

WILDLIFE EXCLUSION FENCING

In areas of heavy snow, where the 10-year average total annual snowfall is greater than 2 m, as identified in Special Provisions, the line post spacing must be reduced to 3.5 m to reduce fence fabric sagging and tearing.

700.23.01 Installation of Wood Posts - Wood posts shall be installed plumb and to a depth of 1500 mm, as indicated on the Drawings. Posts may be either driven or set in excavated holes, provided that a rigid installation is achieved, capable of withstanding a horizontal load of 32 kg (70 lb), applied 1.5 m above the ground, in any direction in the horizontal plane, without any movement in excess of 25 mm. When a wood post is set in an excavated hole, the soil around the wood post must be compacted to the satisfaction of the Ministry Representative. The horizontal load test must be conducted after the post is installed but before the fabric wire is attached. It is the responsibility of the Contractor to conduct and record the horizontal load test. The results of the horizontal load test must be submitted to the Ministry Representative.

Where the slope of the terrain along the fence line approaches 1.5:1 (34°), embedment of wood posts may be reduced to a minimum of 1200 mm, with permission of the Ministry Representative. Where fence gradients exceed 1.5:1 (34°), steel posts must be used, as indicated on the Drawings.

No cutting of pressure treated wood posts will be permitted without authorization of the Ministry Representative. When cutting is authorized, the cut must be only at the top of the post. All cuts must be resealed immediately with a preservative, conforming to CSA O80, having properties equal to or superior to the original pressure treatment solution and of a similar colour.

700.23.02 Installation of Steel Posts – Steel line posts, end posts, corner posts and brace posts embedded in solid rock shall be set in concrete or non-shrink grout.

Where bedrock is encountered on steep slopes at depths less than 1200 mm, the total embedment length may be reduced to 1000 mm. Of the 1000 mm, a minimum of 200 mm shall be set into the bedrock with the remainder set in concrete footings not less than 350 mm in diameter. The top surface of all concrete footings shall be a minimum of 25 mm above ground and slope away from the post to provide positive drainage as indicated on the Drawings.

Steel posts will be installed plumb and to the specified depth, as indicated on the Drawings. Notwithstanding, anything to the contrary in the steel post embedment details shown on the Drawings, any part of the post embedment that is excavated will be backfilled entirely

with well-compacted concrete conforming to Class Y of SS 218 Table 218-A.

Steel posts set in organic or other soft soils shall have a total embedment length of 1800 mm. If the post is driven, the top 800 mm will be set in a concrete footing with a minimum diameter of 350 mm.

Steel corner posts or brace panel posts in soft ground will also have an embedment length of 1800 mm. If the post is driven, the top 1250 mm will be set in concrete footings with a minimum diameter of 350 mm.

Any cut or abraded steel posts must be painted immediately with metal primer paint to inhibit corrosion, according to SS 700.14. Any damage to galvanized coatings must be repaired according to SS 700.14.

Steel posts will be installed with galvanized steel post caps.

Steel posts will be set to provide a rigid installation capable of withstanding a horizontal load of 32 kg (70 lb), applied 1.5 m above the ground, in any direction in the horizontal plane, without any movement in excess of 25 mm. The horizontal load test must be conducted after the post is installed but before the fabric wire is attached. It is the responsibility of the Contractor to conduct and record the horizontal load test. The results of the horizontal load test must be submitted to the Ministry Representative.

700.24 Fence Ties – Fencing shall be tied into structures, gates and existing fencing as staked in the field or as directed by the Ministry Representative. Fencing ties will at no time leave a gap greater than 100 mm.

Care must be taken to ensure that the fencing ties and post installation does not compromise the effectiveness of the adjacent structures.

At bridges, posts may be wood or steel as permitted by the Ministry representative. Where steel posts are used, steel posts shall be bolted to the concrete abutments using Hilti fasteners or an acceptable equivalent. Where wood posts are used, wood posts shall be located as close to the abutments as possible.

At ungulate guards, steel posts will be bolted into the concrete abutments using Hilti fasteners or an acceptable equivalent, wood posts shall be located as close to the ungulate guard abutments as possible.

700.25 Brace Panels – Brace panels will include intermediate brace panels, double intermediate brace

SECTION 700

panels consisting of two intermediate brace panels back to back and end post panels.

Brace panels shall be constructed and installed as shown on the Drawings SP700-01 to SP700-02. Cross wires shall be twisted to provide suitable tension, in the manner illustrated on the Drawing SP700-01.

Bracing wire must be galvanized and a minimum of 9 gauge.

The spacing between adjacent intermediate brace panels, and between intermediate brace panels and end post panels, will not be more than 54 m, unless otherwise permitted by the Ministry Representative.

Intermediate brace panels shall be installed where necessary to meet the foregoing requirement, and also where required by the Ministry representative at changes in vertical or horizontal alignment.

Double brace panels will be used at corners and other sharp changes in the vertical or horizontal alignment, and at any other locations where they are, in the judgement of the Ministry Representative, required to maintain the integrity of the fence.

End post panels will be installed where the fence ties in to structures or gates, at ungulate guards and at any other termination of the fence. The requirement for brace panels at one-way wildlife gates is shown on Drawing SP700-12.1.

700.26 Fence Fabric Installation – The fence fabric will be fastened to posts on the surface facing away from the highway right-of-way, except where the fence is located adjacent to concrete barriers and overpasses.

For wood posts, the wire fence fabric shall be stapled to each post, using a maximum vertical spacing of 150 mm including both the top and bottom wires. Staples will be barbed and galvanized steel, 3.5 mm in diameter with a driven length of at least 50 mm.

The fence fabric will be attached to steel posts with a minimum of four (4) galvanized muffler clamps (e.g. MC12300 P type); one on the top strand, one 0.60 m below the top strand, one 1.20 m below the top strand, and one on the bottom wire of the fence fabric. Intermediate connections will be made every 300 mm along the post with 3.5 mm galvanized wire twisted to form a tight connection.

The wire fence fabric shall be tensioned to provide a uniform pull in order to minimize distortion of the fabric. Each run of fence fabric between brace panels will be

WILDLIFE EXCLUSION FENCING

tensioned before staples are set or clamps tightened.

The tension of the fence fabric will be considered adequate when the fabric cannot be pulled more than 100 mm out of line with a 13.6 kg (30 lb) pull at any point from top to bottom between the posts. The allowable 100 mm will include any deflection of the post, should this occur.

The fence fabric will be as close to the ground as possible, but in any case, the vertical distance between the bottom strand of wire and the existing ground will nowhere exceed 150 mm. Unerodible, clean fill material, neatly trimmed, will be added to obtain this clearance, where practical.

Where the fence crosses gullies or drainage channels, a specially fabricated section of fence will be cut to fit the opening and will be fastened to the bottom wire and the streambed as shown on the Drawings. Alternatively, but only where required by the Ministry Representative, culvert pipe will be installed at specific crossings in accordance with the Special Provisions.

700.27 Connection Treatments at Structures – Fences must be securely attached to walls, abutments, ungulate guards and other structures to ensure stability of the fences and to prevent animals from passing between the fence and the structure. The fence must be attached as per SP700-11 using rockbolts as per SS 206.

700.28 Gates – Hardware shall be securely attached to permit the gate to open correctly and prevent the easy removal of the gate and hardware. Hinges shall be installed to permit the gate to swing back one-way against the fence. Locking hardware shall be of the type specified in Drawing SP700-13.2.

700.29 Lockable Human Access Gates – Access must be provided to allow inspection access from the highway of all points of all bridges, both ends of culverts greater than 2 m in diameter, retaining walls over 2 m in height, tunnels, and farm and wildlife crossing structures.

Lockable human access gates must be located where they can be safely used, avoiding cliffs, steep slopes, swamps, areas frequently under water, and where unstable ground conditions exist. The gates must be located within 25 m of the structures and culverts they provide access to, unless a greater distance is permitted by the Ministry Representative. The gates shall be of the type specified in Drawing SP700-14.1.

Unless otherwise permitted by the Ministry Representative, the minimum number of lockable human gates required are:

SECTION 700

WILDLIFE EXCLUSION FENCING

- a) Culverts greater than 2 m in diameter: 1 gate for each fence located adjacent to the culvert
- b) Retaining walls greater than 2 m in height:
Retaining walls less than 200 m long: 1 gate where the wildlife exclusion fencing abuts the wall
Retaining walls greater than 200 m long: 1 gate at each location of the wall where the wildlife exclusion fencing abuts the wall
- c) Tunnels: 1 gate at each tunnel portal
- d) Bridges: 1 gate for each location where the wildlife exclusion fencing abuts a bridge. The total number of gates required for a bridge may be reduced by the Ministry Representative if sufficient access, during median flow of water conditions, can be provided and maintained with fewer gates.

QUALITY ASSURANCE

700.30 Quality Assurance – The Ministry Representative must be provided a reasonable opportunity to conduct acceptance testing in conformance with SS 700, SS 741, SS 218, SS 909, and SS 316.

The Contractor will disassemble and relocate any elements of the fence necessary for testing at the discretion of the Ministry Representative. If the test of an element is successful, the Ministry shall pay all costs for the replacement of the materials and reconstruction of the element tested.

The Ministry Representative may require any element not tested, or failing the test, to be replaced and retested.

When the Ministry Representative requests a test of an element of the fence and the test fails, all costs will be to the Contractor's account, including the replacement of the materials and reconstruction of the element tested, and all costs associated with the retesting.

700.30.01 Removal and Replacement at Contractor's Expense – The Ministry Representative may require any fencing materials that do not meet the Ministry's specifications to be removed and replaced at the Contractor's expense.

The Ministry Representative may require any constructed fencing or gates that do not meet the Ministry's specifications to be removed and replaced at the Contractor's expense.

MEASUREMENT

700.40 Fencing – Fencing will be measured by the LINEAL METRE. Measurements will be made parallel to the top wire of complete fencing, including any tensioning assemblies, but excluding gate openings.

700.41 One-Way Gates, Lockable Human Access Gates and Double Swing Gates – Gates will be measured by the unit for EACH type and size furnished and/or installed complete in place.

PAYMENT

700.50 Fencing – Payment for FENCING, meeting the requirements as specified to the satisfaction of the Ministry Representative, will be at the Contract Unit Price per lineal metre of complete fencing, including any tensioning assemblies, but excluding one-way gates, lockable human access gates, double swing gates.

The Contract Unit Price(s) shall be accepted as full compensation for furnishing all material and/or taking delivery of Ministry supplied material; as and where noted, all labour, tools, equipment and incidentals to complete the required installation, including the clearing of any additional right of way, construction of temporary fencing, connection to existing fences and/or structures, and final clean up.

700.51 Gates – Payment for ONE-WAY GATES, LOCKABLE HUMAN ACCESS GATES, DOUBLE SWING GATES, meeting the requirements as specified to the satisfaction of the Ministry Representative, will be at the Contract Unit Price for each type and size furnished and/or installed complete in place.

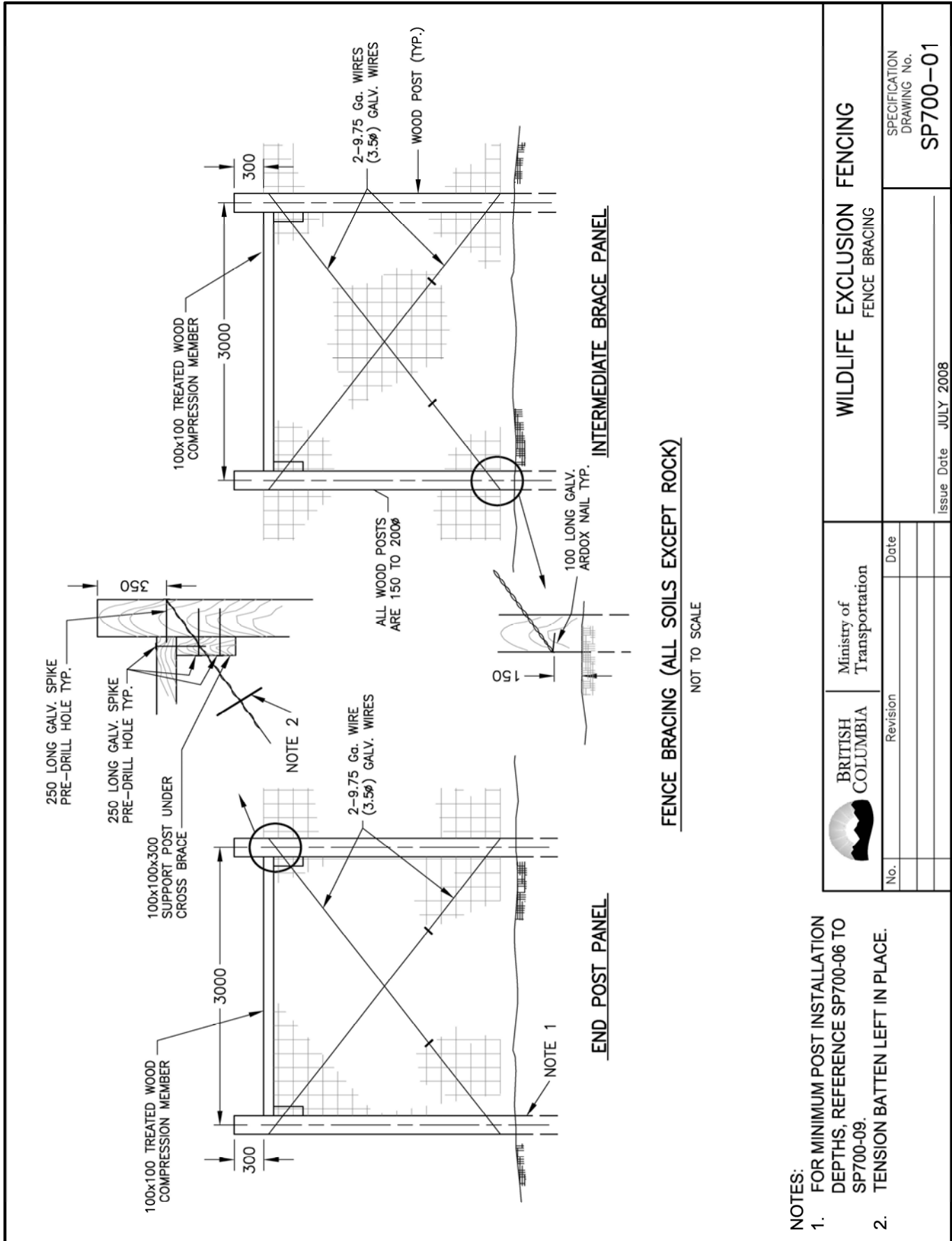

- NOTES:
1. FOR MINIMUM POST INSTALLATION DEPTHS, REFERENCE SP700-06 TO SP700-09.
 2. TENSION BATTEN LEFT IN PLACE.

 BRITISH COLUMBIA		Ministry of Transportation	
No.	Revision	Date	
WILDLIFE EXCLUSION FENCING FENCE BRACING			SPECIFICATION DRAWING No. SP700-01
Issue Date			JULY 2008

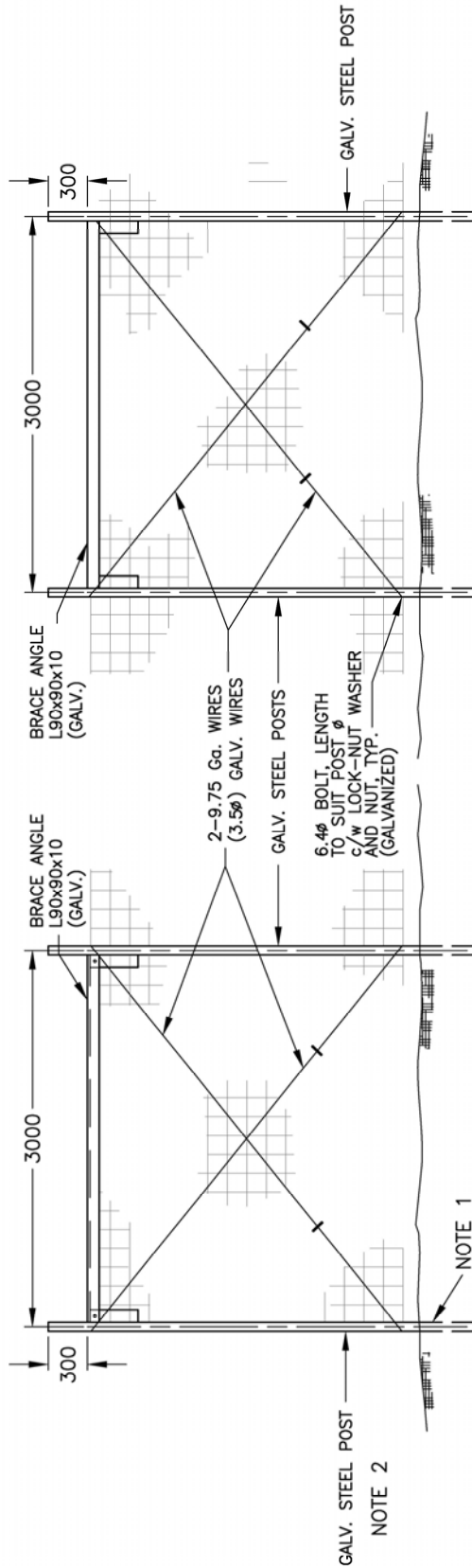

INTERMEDIATE BRACE PANEL

END POST PANEL

FENCE BRACING IN ROCK

NOT TO SCALE

- NOTES:
1. FOR MINIMUM POST INSTALLATION DEPTHS, REFERENCE SP700-06 TO SP700-09.
 2. REPAIR OF DAMAGED ZINC COATING SHALL BE IN ACCORDANCE WITH SS 422.40.
 3. FOR FASTENING DETAILS FOR STEEL POSTS, REFERENCE SP700-10.

 BRITISH COLUMBIA		Ministry of Transportation		WILDLIFE EXCLUSION FENCING FENCE BRACING IN ROCK		SPECIFICATION DRAWING No.	
						SP700-02	
No.	Revision	Date	Issue Date JULY 2008				

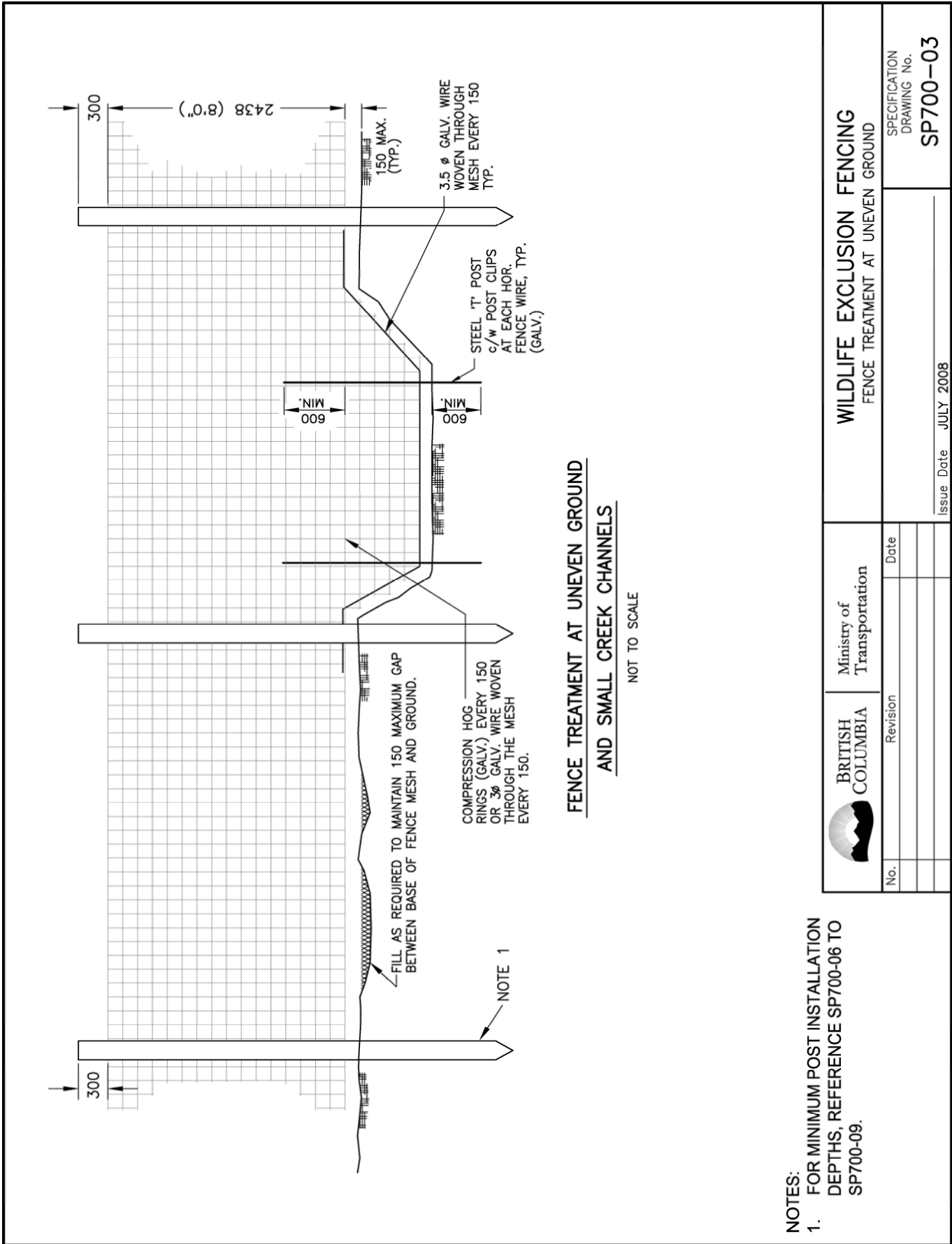



**FENCE TREATMENT AT UNEVEN GROUND
AND SMALL CREEK CHANNELS**

NOT TO SCALE

NOTES:
1. FOR MINIMUM POST INSTALLATION DEPTHS, REFERENCE SP700-06 TO SP700-09.

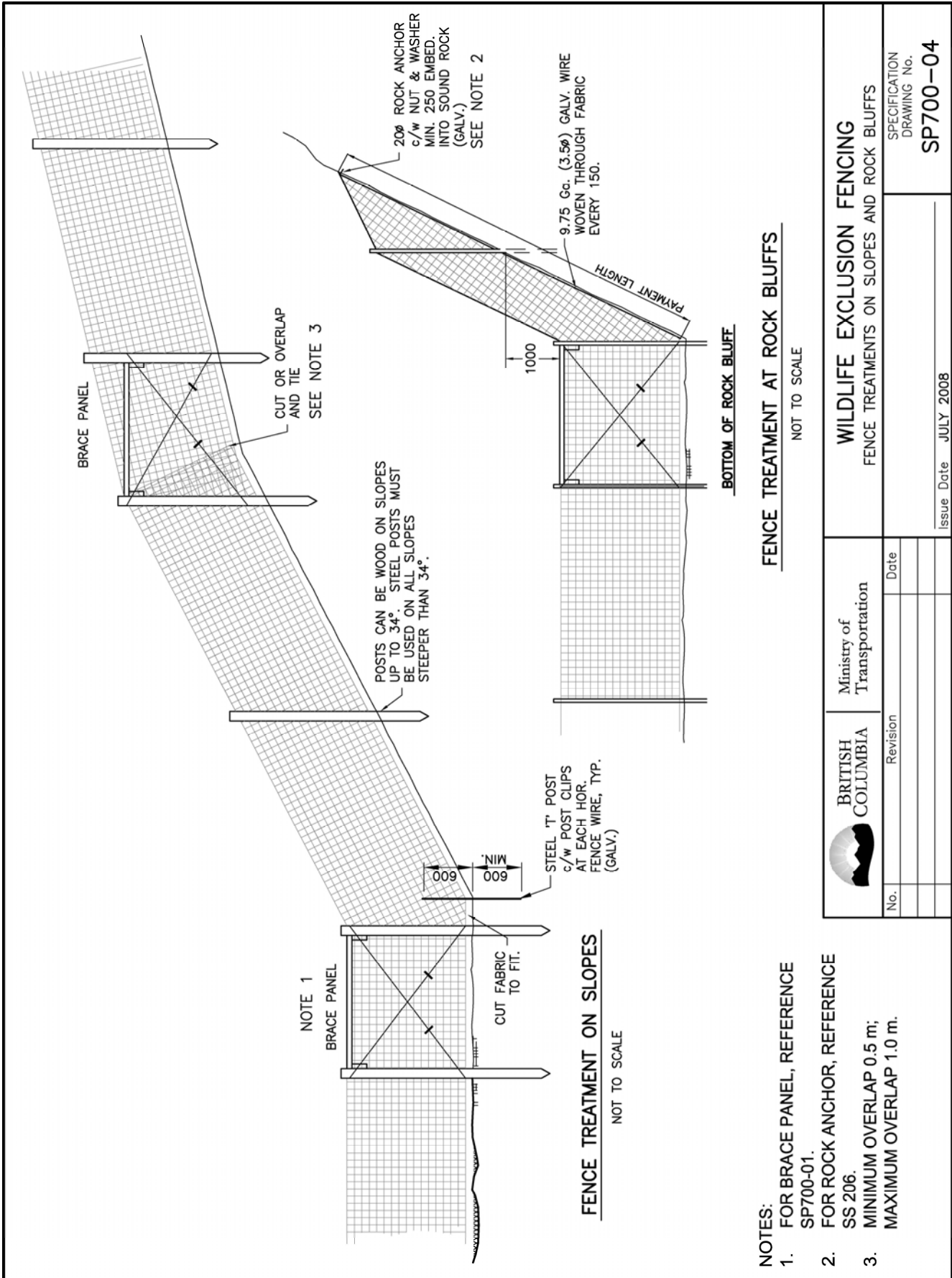
 BRITISH COLUMBIA	Ministry of Transportation	WILDLIFE EXCLUSION FENCING FENCE TREATMENT AT UNEVEN GROUND	
	No. _____ Revision _____ Date _____	Issue Date JULY 2008	SPECIFICATION DRAWING No. SP700-03



 BRITISH COLUMBIA		Ministry of Transportation	
No.	Revision	Date	
WILDLIFE EXCLUSION FENCING FENCE TREATMENTS ON SLOPES AND ROCK BLUFFS			SPECIFICATION DRAWING No. SP700-04
Issue Date JULY 2008			

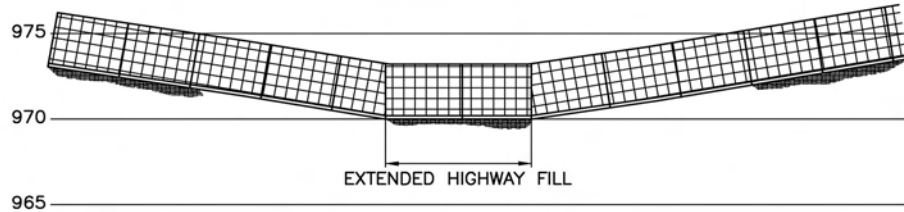

PROFILE
A-A
(ALONG FENCE LINE)

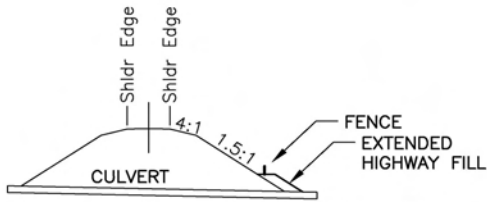

INSTALLATION ON NEW HIGHWAY CONSTRUCTION

SECTION
B-B

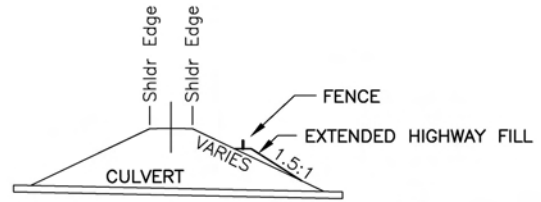

INSTALLATION ON EXISTING HIGHWAY FILL SLOPES

SECTION
B-B

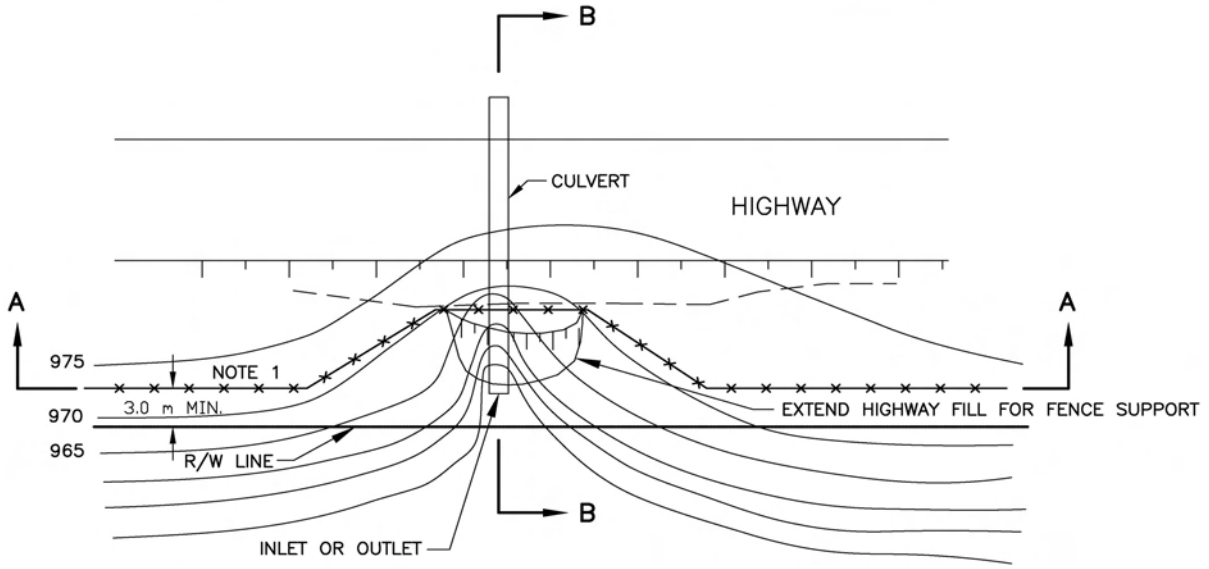

PLAN

FENCE TREATMENT AT LARGE GULLIES

NOTES:

1. FENCE TO BE CONSTRUCTED INSIDE THE RIGHT-OF-WAY LINE AND MUST BE OUTSIDE OF THE HIGHWAY CLEAR ZONE (9.0 m MINIMUM)
2. LOCKABLE HUMAN ACCESS GATE MUST BE PROVIDED WITHIN 25m OF CULVERTS THAT ARE GREATER THAN 2m IN DIAMETER.

 BRITISH COLUMBIA		Ministry of Transportation	WILDLIFE EXCLUSION FENCING FENCE TREATMENTS AT LARGE GULLIES	
No.	Revision	Date	Issue Date JULY 2008	
			SPECIFICATION DRAWING No. SP700-05	

LEVEL GROUND

- ALL POSTS

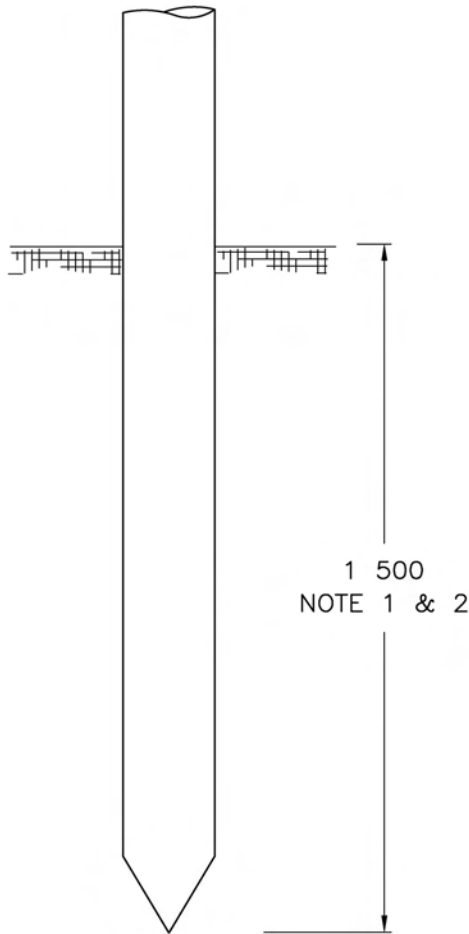

SLOPES LESS THAN 34°

- ALL POSTS

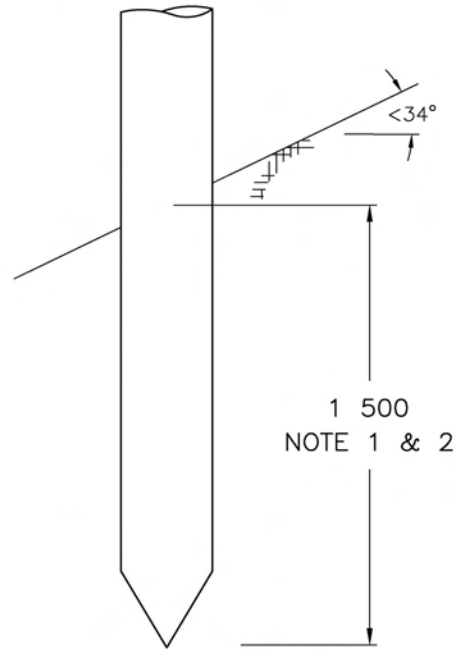

FENCING IN EARTH
(WOOD POSTS)

NOTES:

1. 1500 mm MINIMUM PROVIDED THAT IT MEETS THE REQUIREMENTS OF THE HORIZONTAL LOAD TEST
2. WHENEVER THE REQUIREMENTS OF THE HORIZONTAL LOAD TEST CANNOT BE MET FOR WOOD POSTS, STEEL POSTS SHALL BE USED WHEN DIRECTED BY THE MINISTRY REPRESENTATIVE



BRITISH COLUMBIA

Ministry of Transportation

WILDLIFE EXCLUSION FENCING
EMBEDMENT DETAILS FOR WOOD POSTS IN EARTH

No.	Revision	Date

Issue Date JULY 2008

SPECIFICATION
DRAWING No.
SP700-06

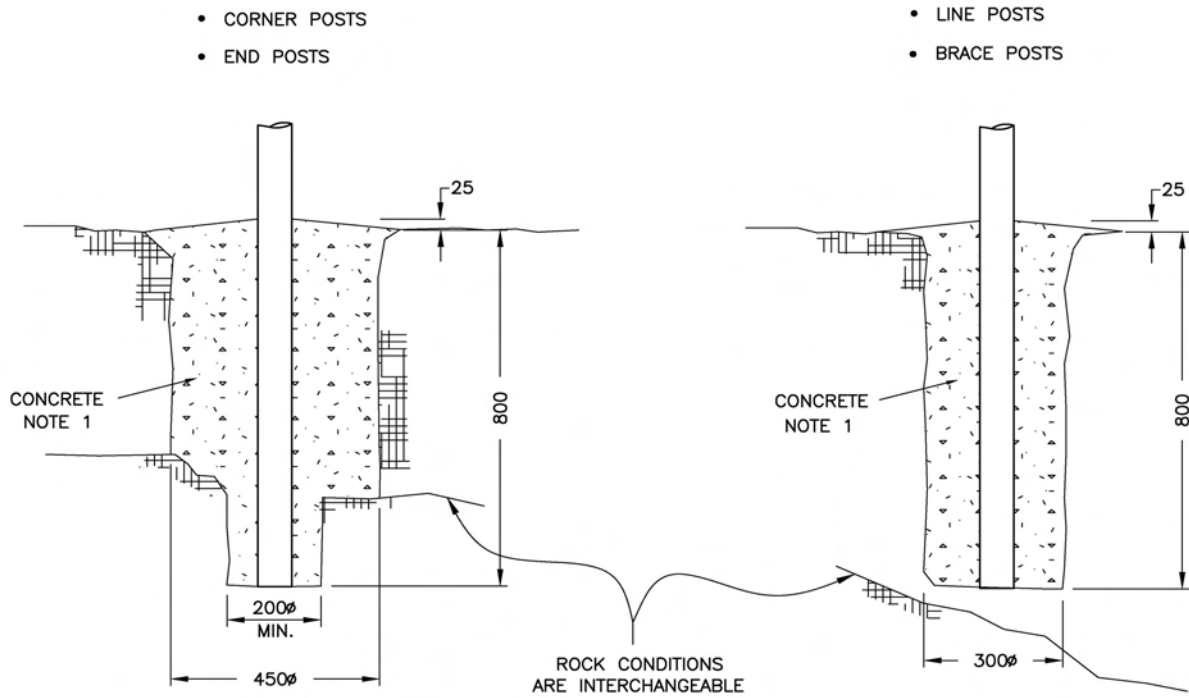

GALVANIZED STEEL POSTS IN ORGANIC MATERIAL OR COMBINATION OF ROCK AND ORGANIC MATERIAL

EMBEDMENT DETAILS
NOT TO SCALE

NOTES:

1. CONCRETE SHALL CONFORM TO SS 218, CLASS C (20mm COARSE AGGREGATE).

 BRITISH COLUMBIA		Ministry of Transportation	WILDLIFE EXCLUSION FENCING EMBEDMENT DETAILS FOR FENCING IN EARTH	
No.	Revision	Date	Issue Date <u>JULY 2008</u>	
			SPECIFICATION DRAWING No. SP700-07	

LEVEL GROUND

- CORNER POSTS
- END POSTS

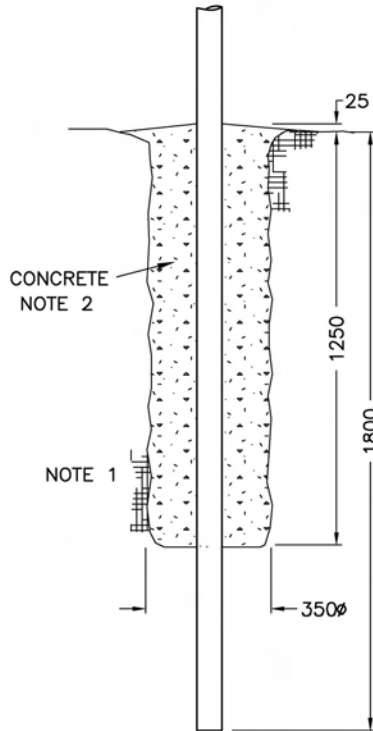

LEVEL GROUND

- LINE POSTS
- BRACE POSTS

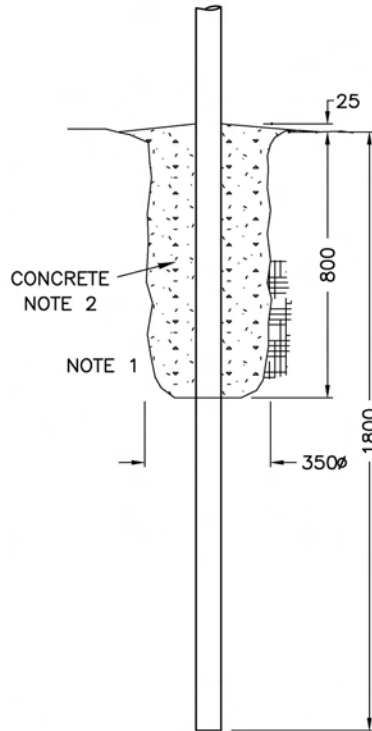

SLOPES
34° TO 50°

- ALL POSTS

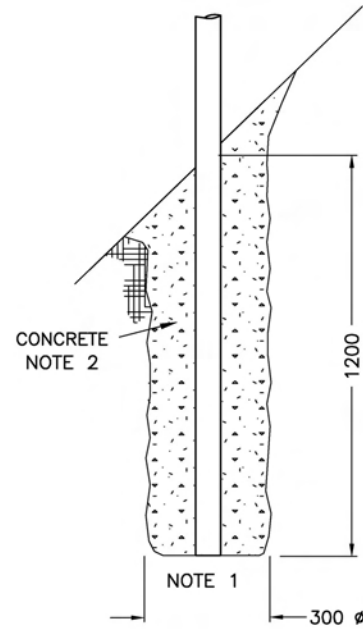

FENCING IN SOFT ORGANIC SOILS OR WETLANDS
(AS DIRECTED BY MINISTRY REPRESENTATIVE)

GALVANIZED STEEL POSTS

EMBEDMENT DETAILS

NOT TO SCALE

NOTE:

1. OVERSIZED HOLES SHALL BE COMPLETELY BACKFILLED WITH CONCRETE OR WELL TAMPED GRAVEL AROUND CONCRETE FOOTING.
2. CONCRETE MUST CONFORM TO SS 218, CLASS C (20mm COARSE AGGREGATE).

 BRITISH COLUMBIA		Ministry of Transportation	WILDLIFE EXCLUSION FENCING EMBEDMENT DETAILS FOR SOFT ORGANIC SOILS OR WETLANDS	
No.	Revision	Date	Issue Date JULY 2008	
			SPECIFICATION DRAWING No. SP700-08	

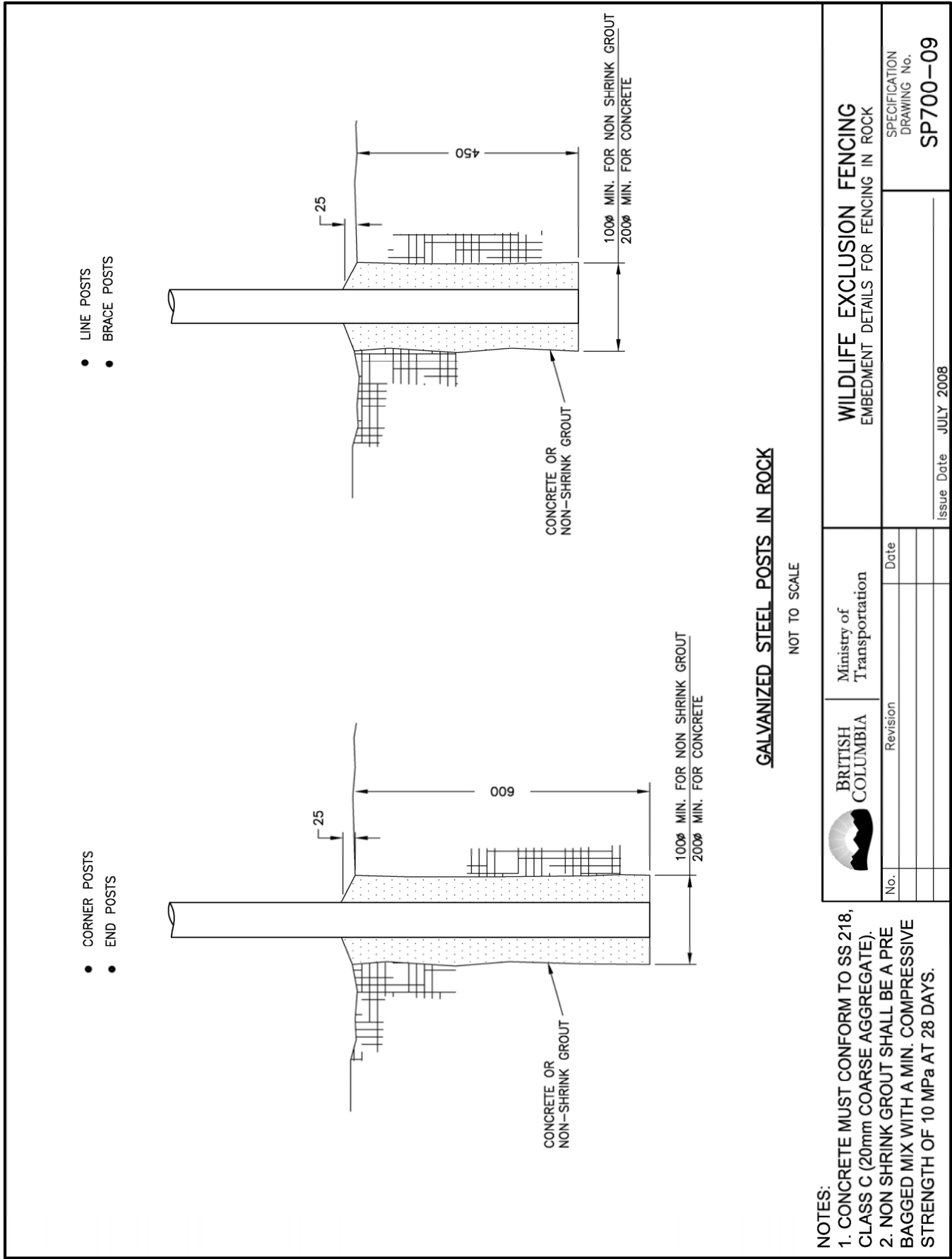

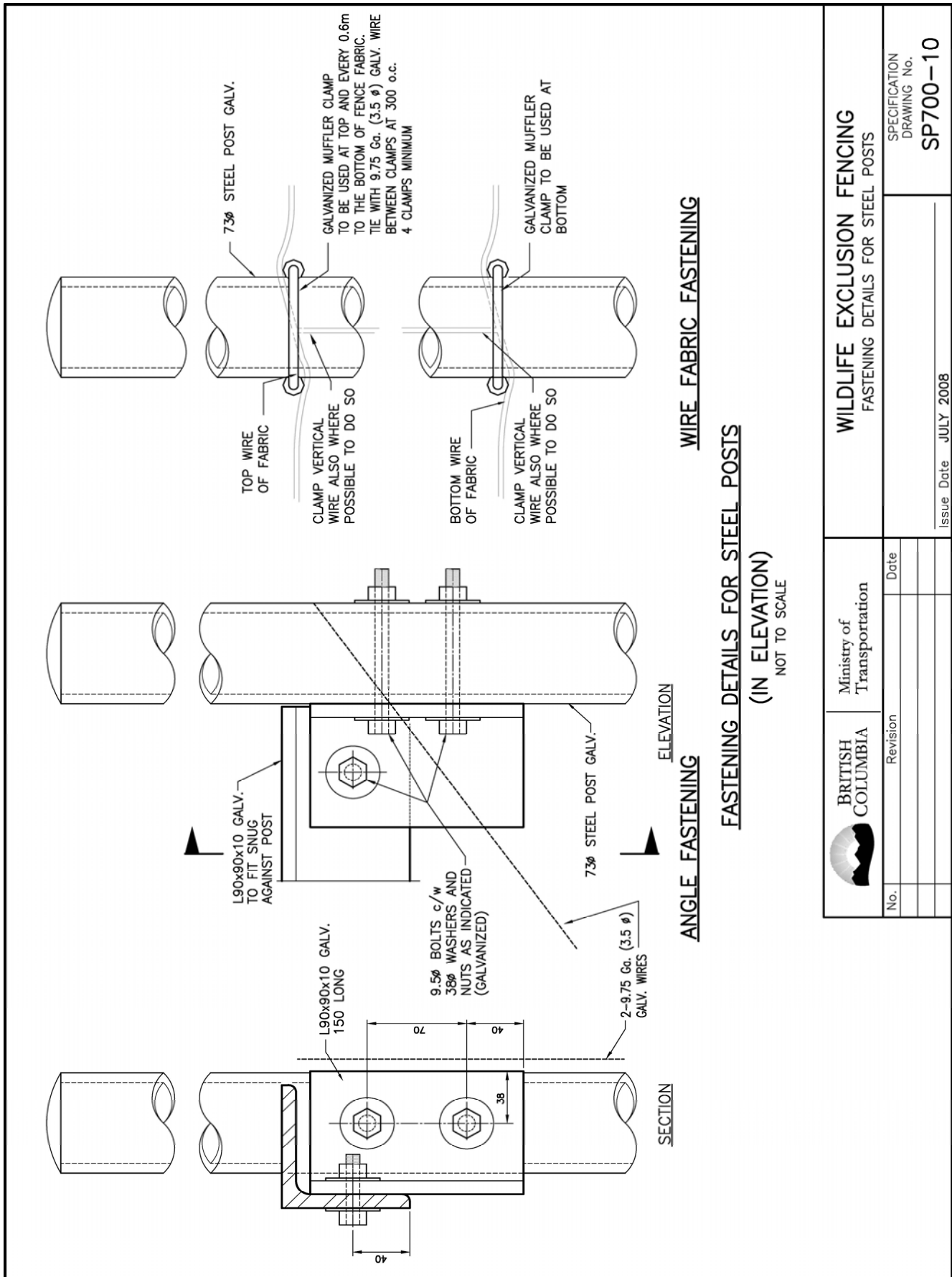

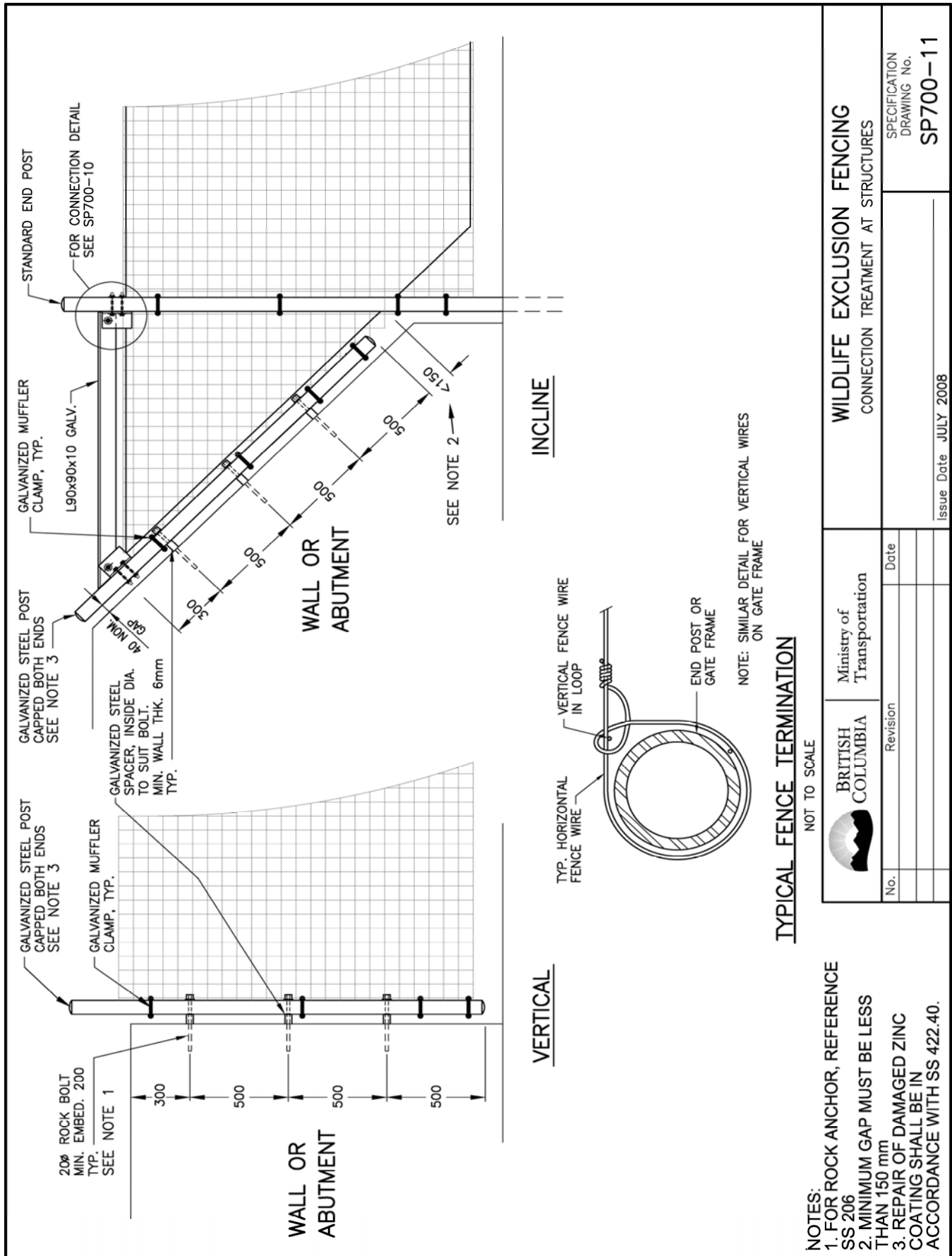

NOTES:
 1. FOR ROCK ANCHOR, REFERENCE SS 206
 2. MINIMUM GAP MUST BE LESS THAN 150 mm
 3. REPAIR OF DAMAGED ZINC COATING SHALL BE IN ACCORDANCE WITH SS 422.40.

TYPICAL FENCE TERMINATION

NOT TO SCALE

BRITISH COLUMBIA Ministry of Transportation

WILDLIFE EXCLUSION FENCING
 CONNECTION TREATMENT AT STRUCTURES

No.	Revision	Date

Issue Date **JULY 2008**
 SPECIFICATION DRAWING No. **SP700-11**

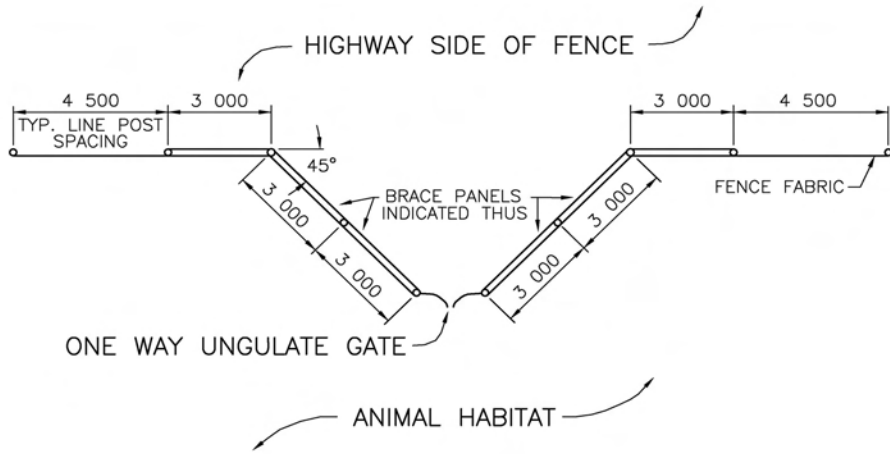

PLAN VIEW
SINGLE ONE WAY UNGULATE GATE LAYOUT
 NOT TO SCALE

NOTES:

- 1) NYLON, OR OTHER SUITABLE PLASTIC, BUSHINGS SHALL BE INSTALLED ON THE GATE HINGES, TO LAY AGAINST THE MOUNTING PLATE.
- 2) 38mm X 50mm PATCHES OF 3mm NEOPRENE RUBBER SHALL BE PERMANENTLY ATTACHED TO EACH SWINGING SECTION, USING A SILICON ADHESIVE, SO THAT THE GATE CAN BE SLAMMED SHUT WITHOUT NOISE.
- 3) ALL METAL IN THE GATE ASSEMBLY SHALL BE GALVANIZED.
- 4) THE GATE TINES ONLY SHALL BE HEAT TREATED TO ROCKWELL HRC 30 TO 35.
- 5) ACID BATH TREATMENT OF THE TINES PRIOR TO GALVANIZING SHALL BE CONTROLLED TO MINIMIZE POTENTIAL WEAKENING OF WELDS.
- 6) GATES SHALL BE CAREFULLY FABRICATED AND WELDED TO AVOID BINDING. COMPLETED GATES SHALL BE TEST ASSEMBLED IN SHOP, ADJUSTED AND LUBRICATED TO SWING FREELY AND QUIETLY SHUT FROM ANY POSITION.
- 7) ALL STEELWORK TO BE GALVANIZED AFTER FABRICATION IN ACCORDANCE WITH SS422. GALVANIZING TO BE IN ACCORDANCE WITH C.S.A. SPECIFICATION G164, TABLE 1.
- 8) DRAWING TO BE READ IN CONJUNCTION WITH DRAWINGS SP700-12.2 TO 12.7
- 9) BACKFILL TO BE a) IN FREE DRAINING NON-COHESIVE SOILS – NATIVE MATERIALS
 b) IN COHESIVE SOILS – MIX NATIVE MATERIAL 1 TO 1 WITH COARSE ROCK AGGREGATE (MAX 75mm ϕ)
- 10) FABRICATION TO BE IN ACCORDANCE WITH STANDARD SPECIFICATION SECTION 422 MISCELLANEOUS STEELWORK.

 BRITISH COLUMBIA		Ministry of Transportation	ONE WAY UNGULATE GATE UNGULATE GATE SHOP DRAWING ASSEMBLY LAYOUT	
No.	Revision	Date	Issue Date	SPECIFICATION DRAWING No. SP700-12.1

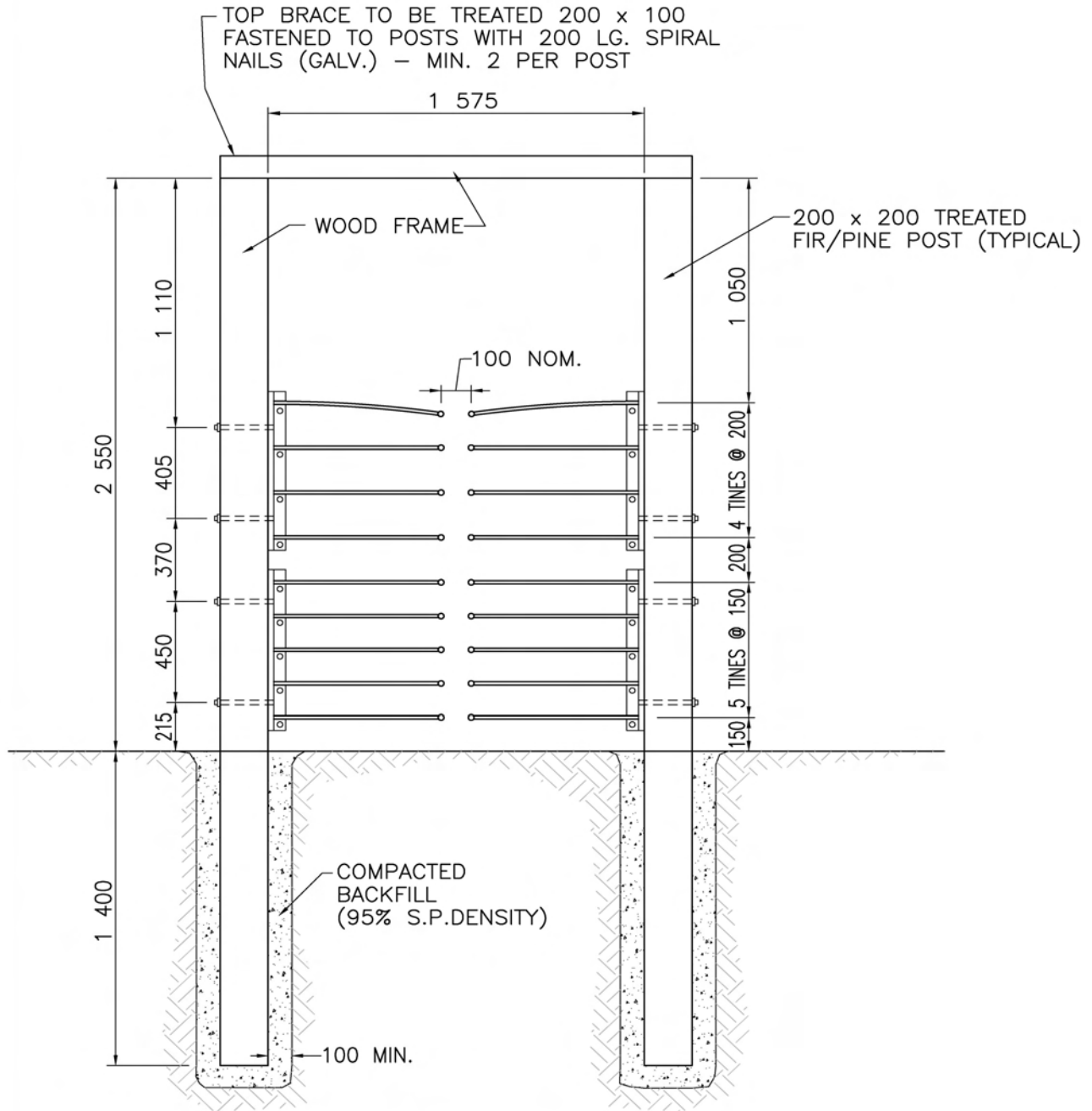

ONE WAY UNGULATE GATE ASSEMBLY

NOT TO SCALE



BRITISH COLUMBIA

Ministry of Transportation

ONE WAY UNGULATE GATE
UNGULATE GATE SHOP DRAWING ASSEMBLY LAYOUT

No.	Revision	Date

Issue Date JULY 2008

SPECIFICATION DRAWING No.
SP700-12.2

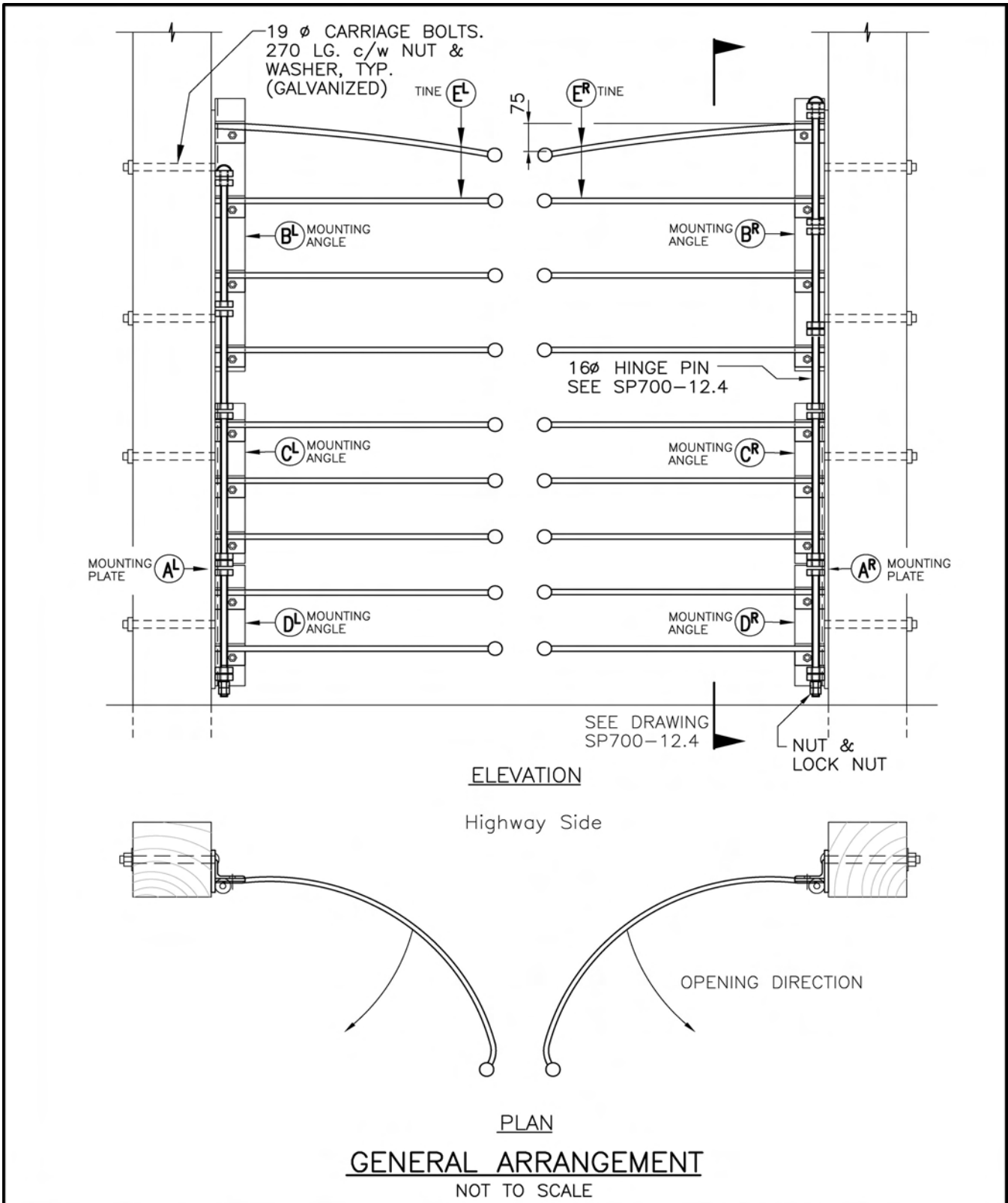

 BRITISH COLUMBIA		Ministry of Transportation	ONE WAY UNGULATE GATE GENERAL GATE ASSEMBLY	
No.	Revision	Date	Issue Date JULY 2008	
SPECIFICATION DRAWING No. SP700-12.3				

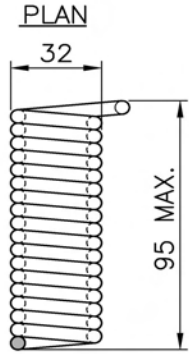
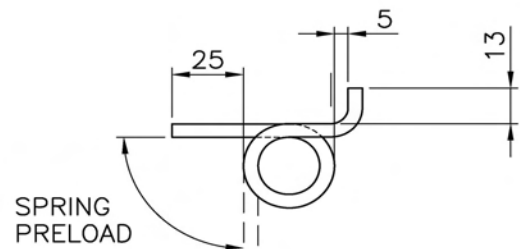
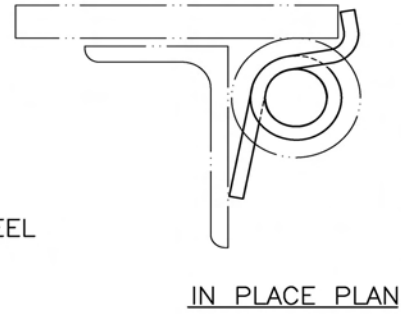
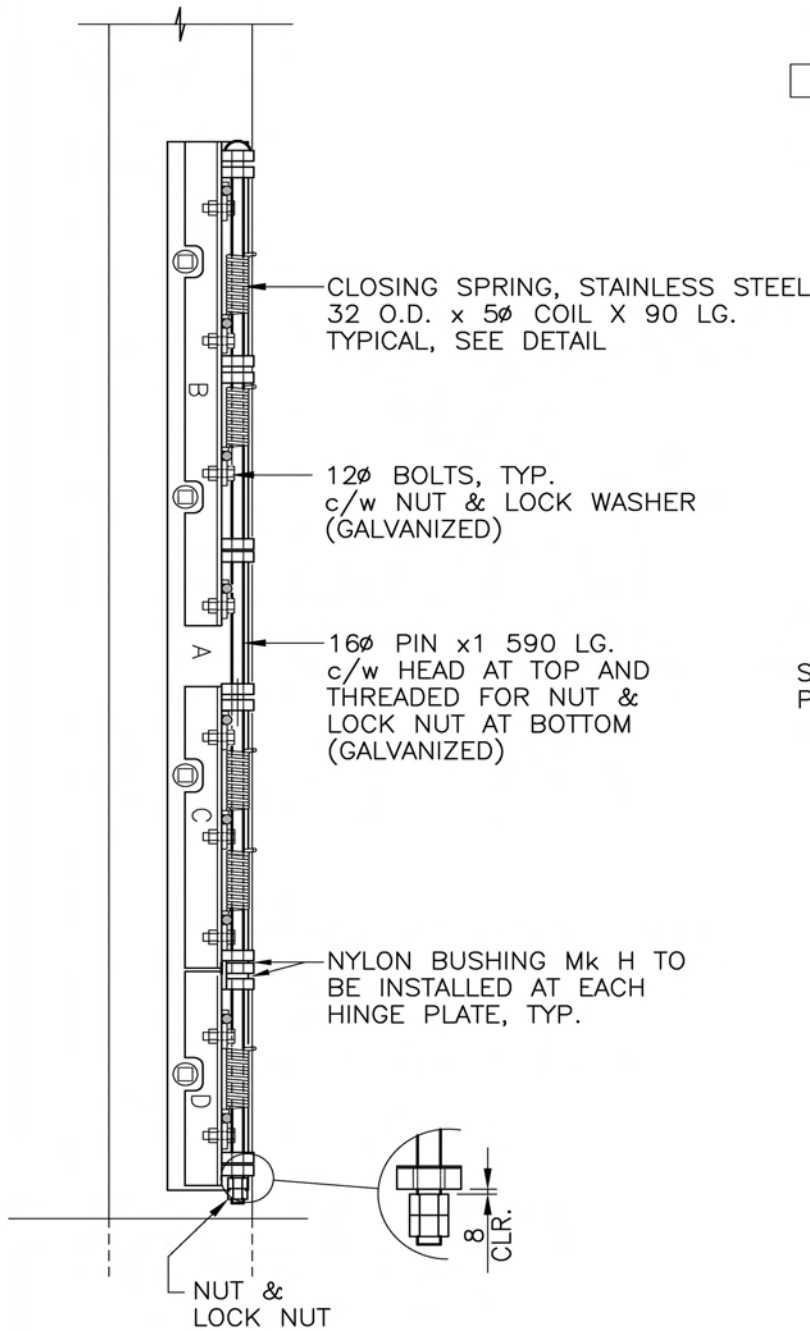

CLOSING SPRING
PROPOSED LAYOUT
10 REQUIRED

SECTION

 BRITISH COLUMBIA		Ministry of Transportation	ONE WAY UNGULATE GATE GATE ASSEMBLY – SIDE VIEW	
No.	Revision	Date	Issue Date JULY 2008	
			SPECIFICATION DRAWING No. SP700-12.4	

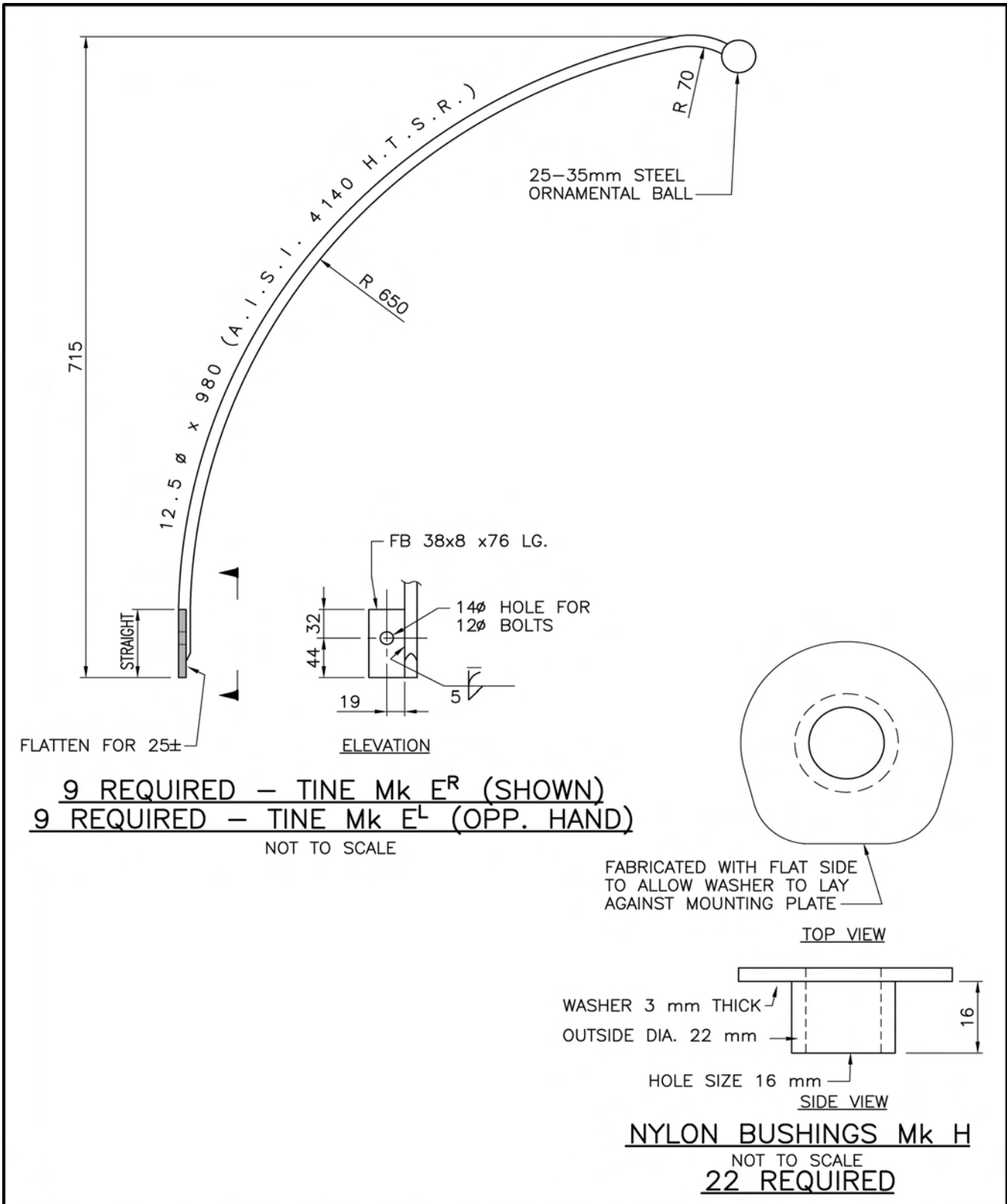

 BRITISH COLUMBIA		Ministry of Transportation	ONE WAY UNGULATE GATE TINE & BUSHING	
No.	Revision	Date	Issue Date JULY 2008	
			SPECIFICATION DRAWING No. SP700-12.5	

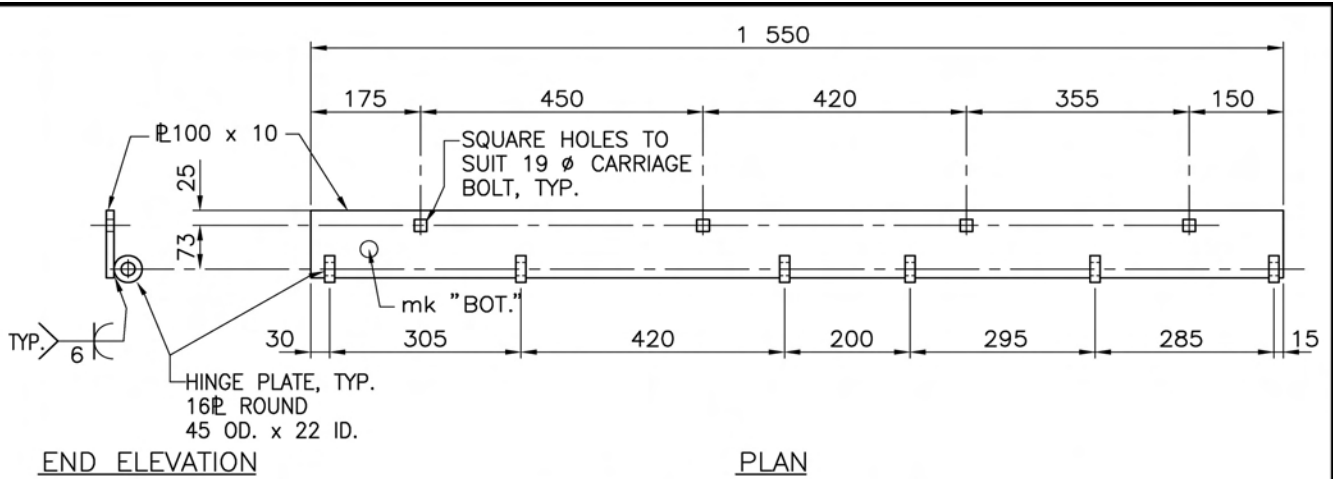

ONE REQUIRED – MOUNTING \square – Mk. A1^R (SHOWN)
ONE REQUIRED – MOUNTING \square – Mk. A1^L (OPP. HAND)

NOT TO SCALE

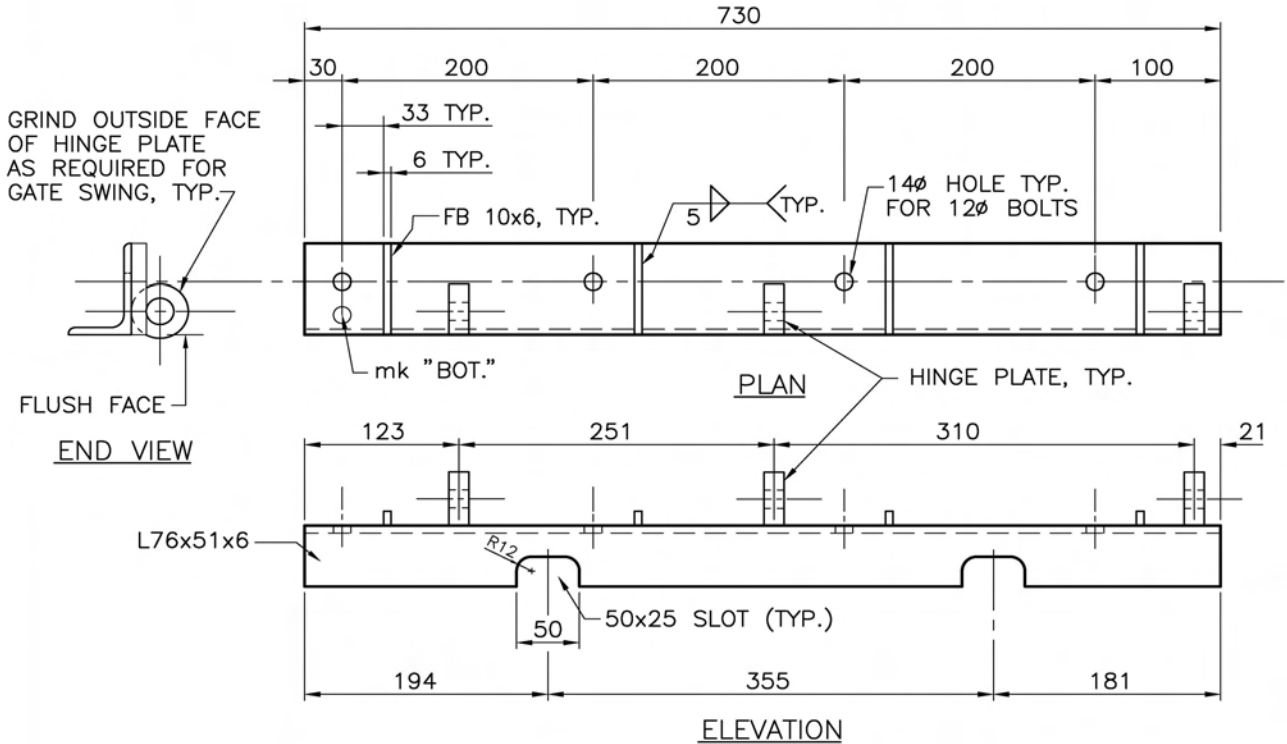

ONE REQUIRED – ANGLE Mk B^R (SHOWN)
ONE REQUIRED – ANGLE Mk B^L (OPP. HAND)

NOT TO SCALE

 BRITISH COLUMBIA		Ministry of Transportation	ONE WAY UNGULATE GATE MOUNTING BRACKETS Mk. A & B	
No.	Revision	Date	Issue Date JULY 2008	
			SPECIFICATION DRAWING No. SP700-12.6	

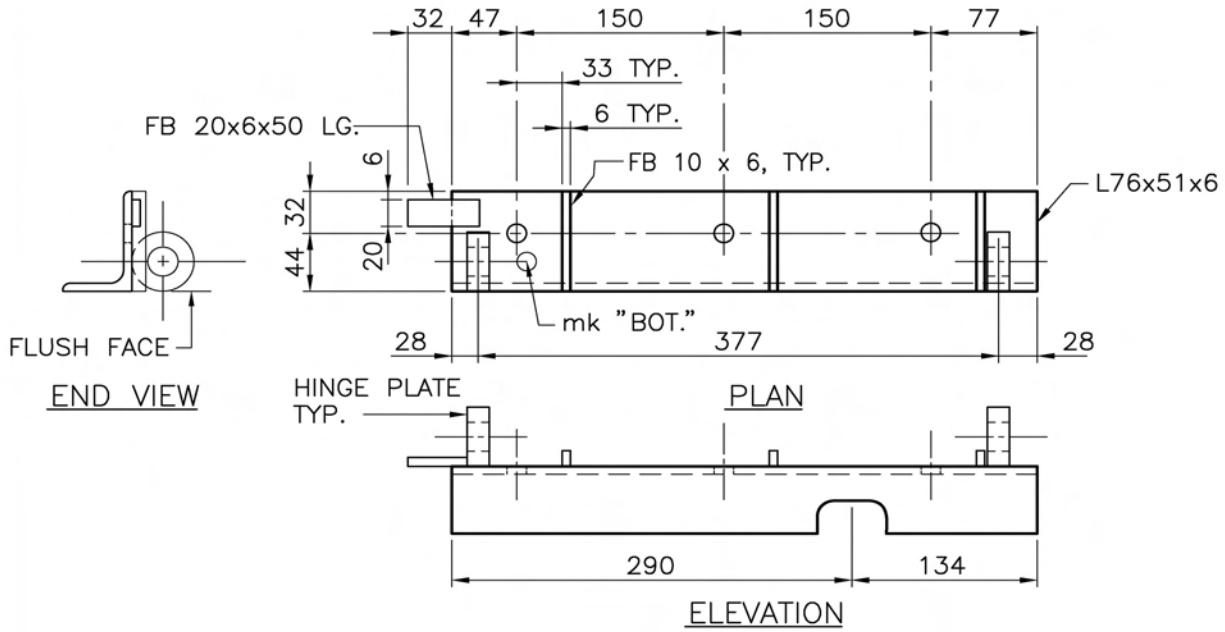

ONE REQUIRED – ANGLE Mk. C^R (SHOWN)
ONE REQUIRED – ANGLE Mk. C^L (OPP. HAND)

NOT TO SCALE

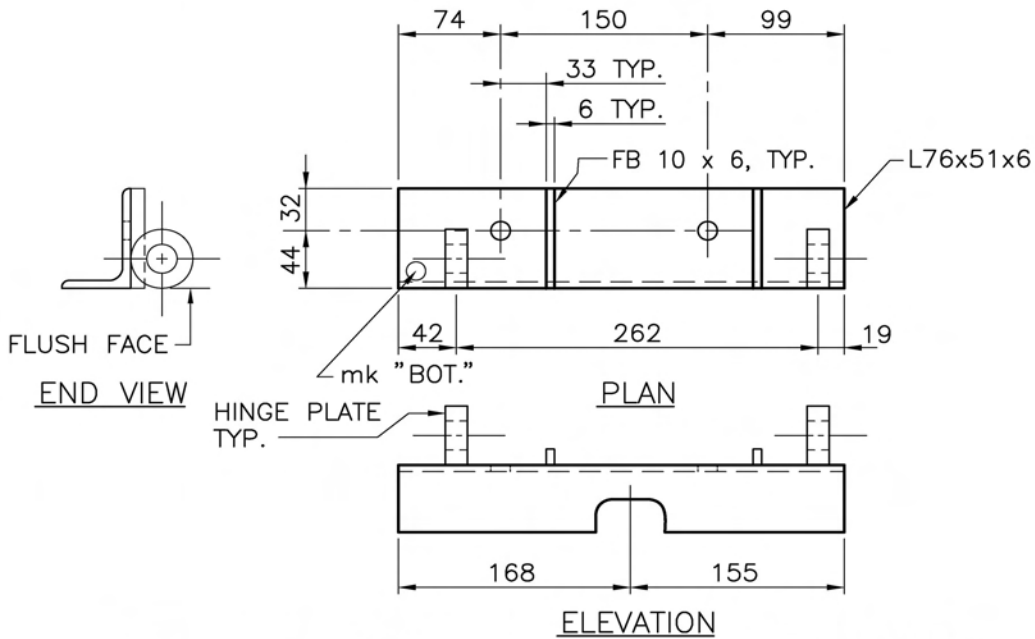

ONE REQUIRED – ANGLE Mk. D^R (SHOWN)
ONE REQUIRED – ANGLE Mk. D^L (OPP. HAND.)

NOT TO SCALE

 BRITISH COLUMBIA		Ministry of Transportation	ONE WAY UNGULATE GATE MOUNTING BRACKETS Mk. C & D	
No.	Revision	Date	Issue Date JULY 2008	
			SPECIFICATION DRAWING No. SP700-12.7	

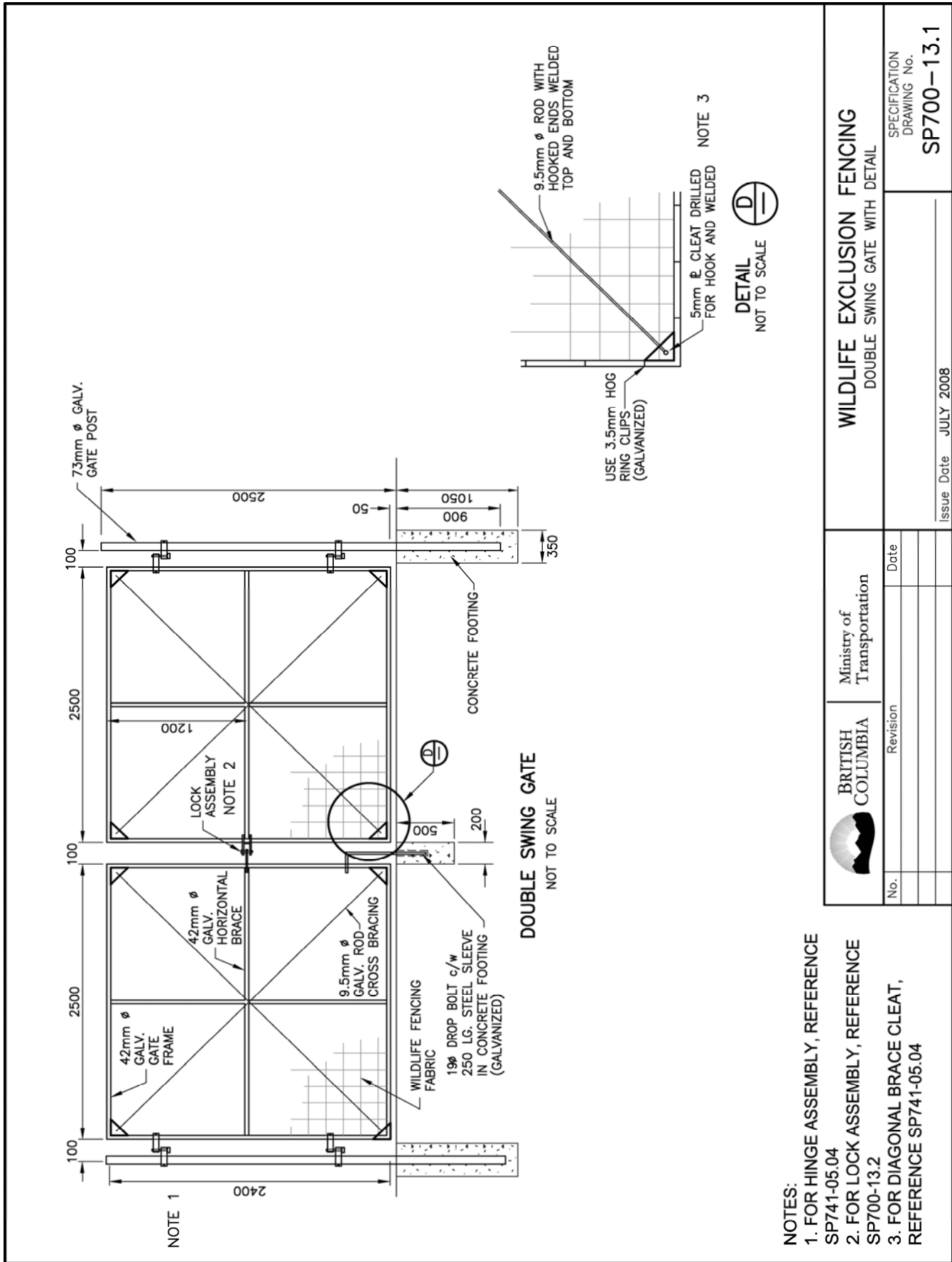

- NOTES:
1. FOR HINGE ASSEMBLY, REFERENCE SP741-05.04
 2. FOR LOCK ASSEMBLY, REFERENCE SP700-13.2
 3. FOR DIAGONAL BRACE CLEAT, REFERENCE SP741-05.04

WILDLIFE EXCLUSION FENCING
DOUBLE SWING GATE WITH DETAIL

BRITISH COLUMBIA
Ministry of Transportation

No.	Revision	Date

Issue Date JULY 2008

SPECIFICATION
DRAWING No.

SP700-13.1

DETAIL
NOT TO SCALE

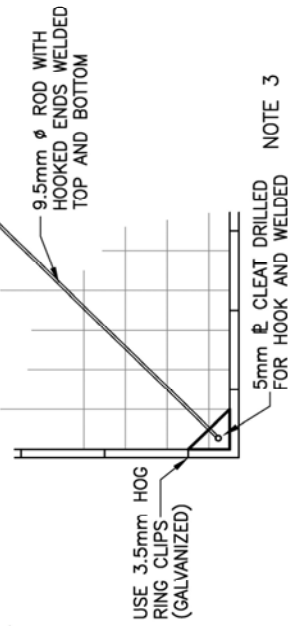

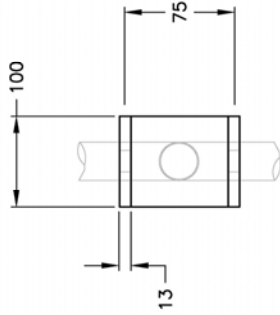

FRONT VIEW

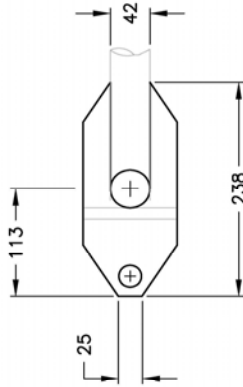

TOP VIEW

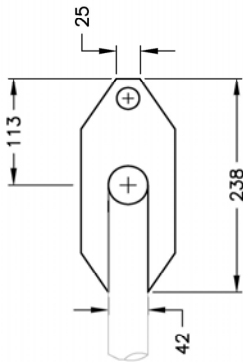

TOP VIEW

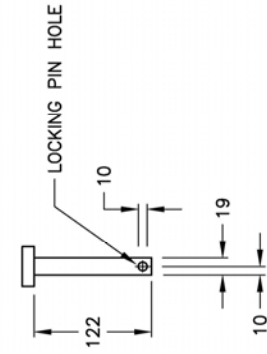

PIN DIMENSION

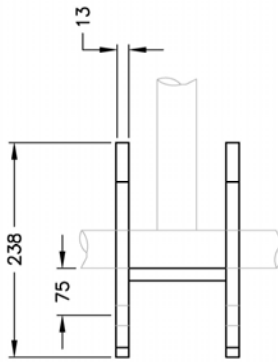

SIDE VIEW

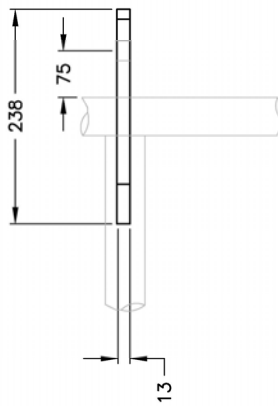

SIDE VIEW

LOCK ASSEMBLY DETAIL -- RIGHT GATE
NOT TO SCALE

LOCK ASSEMBLY DETAIL -- LEFT GATE
NOT TO SCALE

LOCK MECHANISM DETAIL

NOTES:
1. FOR DOUBLE SWING GATE,
REFERENCE SP700-13.1

WILDLIFE EXCLUSION FENCING
DOUBLE SWING GATE LOCK MECHANISM DETAILS

SPECIFICATION
DRAWING No.
SP700-13.2

BRITISH COLUMBIA
Ministry of
Transportation

No.	Revision	Date

Issue Date JULY 2008

LOCKABLE HUMAN ACCESS GATE

NOT TO SCALE

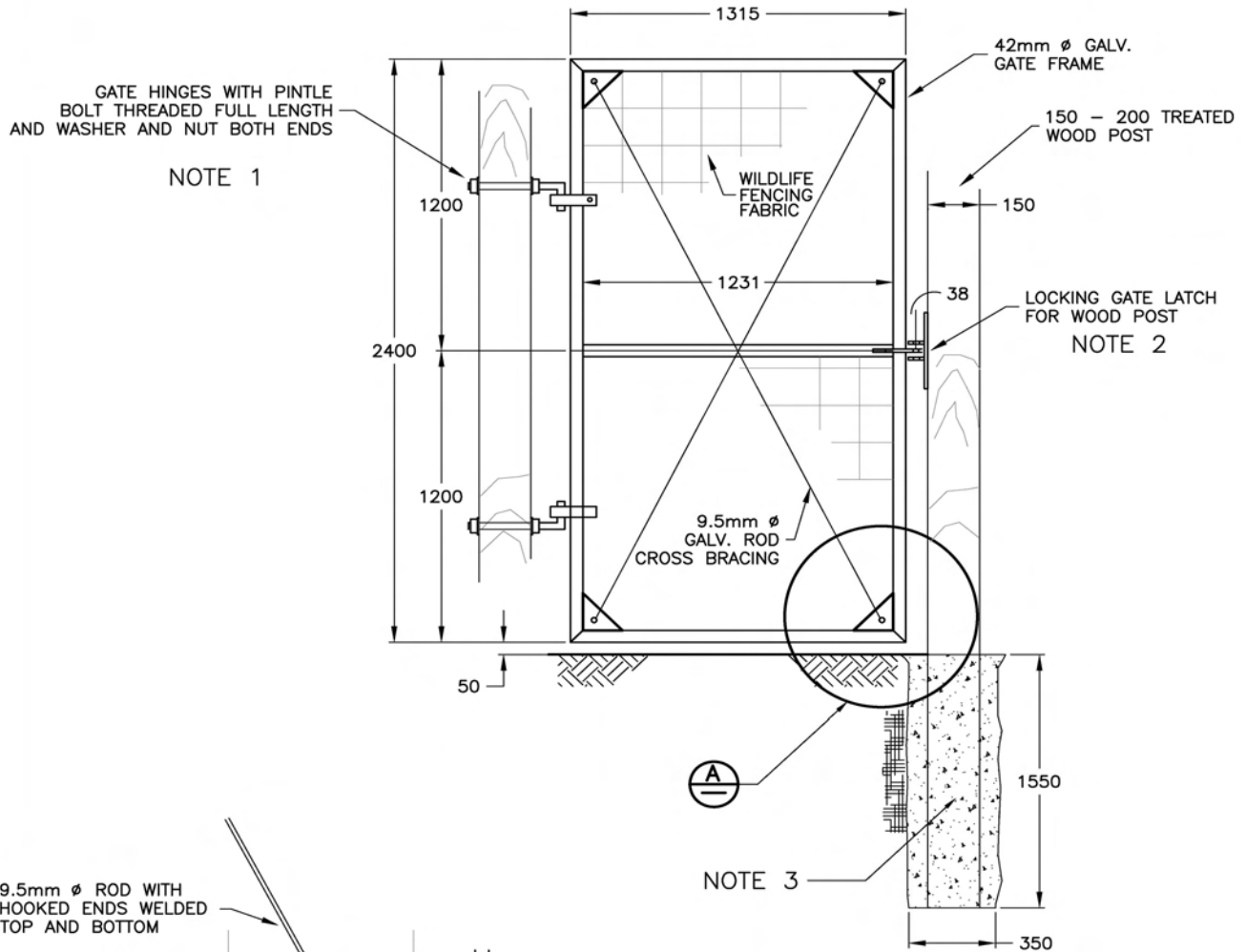

NOTE 1

NOTE 2

NOTE 3

9.5mm ϕ ROD WITH HOOKED ENDS WELDED TOP AND BOTTOM

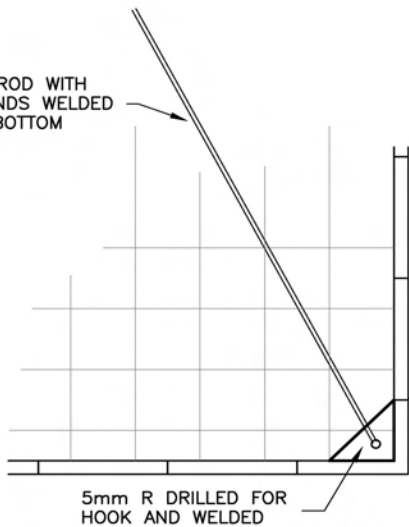

DETAIL NOT TO SCALE **A**

NOTES:

1. GATE HINGE, REFERENCE SP741-04.04
2. GATE LATCH FOR WOOD POST, REFERENCE SP700-14.2
3. WELL TAMPED BACKFILLS (A) IN FREE DRAINING, NON-COHESIVE SOILS, USE NATIVE MATERIALS (B) IN COHESIVE SOILS, MIX NATIVE MATERIAL 50-50 WITH COARSE ROCK AGGREGATE (MAX. 75mm ϕ)

 BRITISH COLUMBIA		Ministry of Transportation	WILDLIFE EXCLUSION FENCING LOCKABLE HUMAN ACCESS GATE AND DETAIL	
No.	Revision	Date	SPECIFICATION DRAWING No. SP700-14.1	
Issue Date JULY 2008			Issue Date JULY 2008	

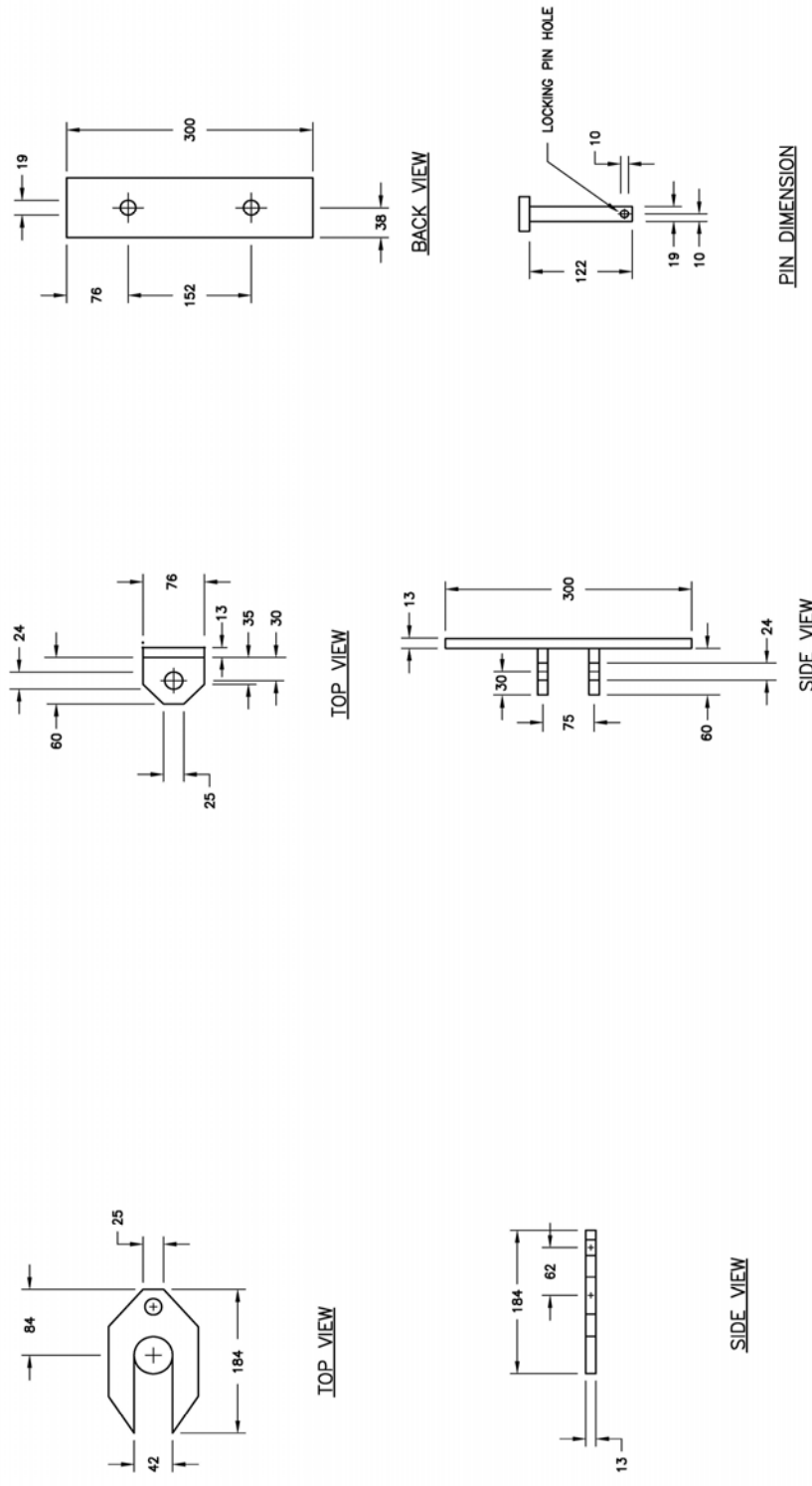

LOCK MECHANISM DETAIL
LOCK ASSEMBLY DETAIL - GATE
 NOT TO SCALE

LOCKING GATE LATCH MECHANISM DETAIL
LATCH ASSEMBLY DETAIL - WOOD POST
 NOT TO SCALE

NOTES:
 1. FOR HUMAN ACCESS GATE,
 REFERENCE SP700-14.1

 BRITISH COLUMBIA	Ministry of Transportation	WILDLIFE EXCLUSION FENCING HUMAN ACCESS GATE WOOD POST LATCH ASSEMBLY	
	Revision	Date	SPECIFICATION DRAWING No. SP700-14.2
No.	Issue Date	Issue Date	Issue Date

THIS PAGE IS LEFT INTENTIONALLY BLANK

NEW SECTION

SECTION 741

FENCE CONSTRUCTION

DESCRIPTION

741.01 Scope – This Section covers the construction of wire fencing with wood and/or metal posts, gates, wood privacy and noise barrier fencing, and steel sidewalk fencing and, with reference to Drawings of the SP741 series, is intended to specify acceptable standards and some optional features as may be required by the Special Provisions.

Alternative construction may be called for by the Drawings, the Special Provisions or instructions of the Ministry Representative, and alternative methods may be acceptable upon submission to the Ministry Representative.

See SS 700 for wildlife exclusion fencing.

MATERIALS

741.11 General – Material for fencing including wire fabric, barbed and high-tensile wire, chain link mesh and metal posts and rails are specified in SS 316. Wood fence posts are specified in SS 909.

Chain link fabric as protection on rock slopes is covered by SS 207 and SS 316.

All materials shall be supplied by the Contractor unless Ministry-supply is specified in the Special Provisions.

The types of standard wire and chain link fencing covered by this Section are designated in Table 741-A. Tentative requirements for High-tensile Smooth-wire Fences are included.

TABLE 741-A TYPES OF STANDARD WIRE AND CHAIN LINK FENCING

TYPE A	Special Wire Fabric Fence for use only on railway right-of-way
TYPE B	Standard Wire Fabric Fence
TYPE C	Standard Barbed Wire Fence
TYPE D	Chain Link Fence

Note: Drawing SP741-01.01 indicates the general requirements of Types A and B Fences, Drawing SP741-02.01 indicates those of Type C Fences, and Drawing SP741-05.01 indicates those for Type D. The requirements for Type C are acceptable to the Provincial Wildlife Branch and the B.C. Cattlemen's Association.

741.12 Standard Wire Type A, B & C Fences and Gates – Materials generally shall be in accordance with the requirements set out on Drawings SP741-01.01 and SP741-02.01, the relevant subsections of SS 316 and SS 909 and/or the Special Provisions.

Preservative treatment for protecting field cuts and notches and for making good any superficial damage to treated wood

posts, braces and anchors, where permitted by the Ministry Representative, shall be compatible with the original pressure treatment for application in two separate heavy coatings.

Touch-up treatment for damaged galvanizing of steel posts and braces shall be a heavy application of a zinc rich colour matched paint to CGSB Standard 1-GP-181M Specification for Ready Mixed Zinc Rich Coating.

741.12.01 Gates – Gates shown on the Drawings shall be of the prefabricated type indicated on Drawings SP741-04.04, SP741-04.05 and as specified in SS 16.11 and/or as specified in the Special Provisions.

741.13 High-tensile Smooth-wire Fences – Materials to be supplied include:

- high-tensile smooth galvanized wire 2.5 mm nominal diameter
- mechanical wire splices and fasteners for high-tensile wire
- in-line high-tensile wire tensioning devices
- metal or wood droppers for high-tensile fencing.

Wood posts and braces shall be supplied by the Contractor in accordance with the requirements of SS 909 together with steel posts, gates and hardware, brace wire, dowels, staples and the like in accordance with the relevant subsections of SS 316.

741.14 Chain Link Type D Fences and Gates – Chain link mesh, steel pipe and accessory materials generally shall be in accordance with the requirements set out on Drawings SP741-05.01 and SP741-05.02, the relevant subsections of SS 316, and/or the Special Provisions.

741.14.01 Gates – Gates shown on the Drawings shall be of the type indicated on Drawings SP741-05.03 and SP741-05.04 and/or specified by the Special Provisions, and shall be equipped with hinges (or sliding) and locking hardware.

741.15 Wood Fences – Materials used for the fabrication and installation of wood fences shall be as follows:

- Concrete footings:** Minimum 20 MPa compressive strength concrete, comprised of aggregate, sand and Portland cement (4:2:1).
- Lumber:** Rough sawn or dressed, as specified, shall be of Western Red Cedar with:
 - Wood posts and stringers of "No. 1 Structural" grade posts and framing or plank
 - Boards and planks of "Quality Fencing" grade except where noise barrier fencing is specified for "Select Fencing" or plank equivalent.

Other species may be specified or approved and shall be of equivalent grades with pressure preservative treatment in accordance with CSA Standard O80 and compatible with staining requirements.

All lumber shall be in conformity with the NLGA "Standard Grading Rules for Canadian Lumber."

iii) Galvanized steel pipe: 48 mm OD for privacy fence posts shall conform to the requirements of SS 316.10 with weatherproof caps where open ends are not covered by wood members.

iv) Steel: Steel used as posts for noise barrier fences or as wood post supports shall be of the structural shape(s) indicated in accordance with CSA Standard G40.21, Grade 300W and where galvanized, hot dipped to the requirements of CSA G164.

v) Fastenings: Bolts generally shall conform to ASTM A 307, nuts to ASTM A 563 Grade A, plain washers to ANSI B27.2 Type A, plate washers, where required, to ASTM A 36; all galvanized according to CSA G164. Nails shall be casing headed heavy gauge of appropriate length, hot dip galvanized with deformed shank (annular, barbed or helical) for noise barrier fence plank fixing.

vi) Finish: Penetrating stain with preservative shall be of type and colour specified at least conforming to CGSB Standards 1-GP145M and 204M, to all surfaces prior to prefabrication or installation and on any cuts before final fitment.

CONSTRUCTION

741.31 Provision of Fencing – Fencing of the type(s) called for shall be carried out at the locations and as shown on the Drawings with the materials to the height, spacing and with accessories all in accordance with the details indicated on the Drawings, Standard Specifications, Special Provisions and SP Drawings or to the direction of the Ministry Representative.

All material shall be supplied by the Contractor except where supply in whole or in part by the Ministry f.o.b. the Contractor's job site yard or Ministry's yard is specified.

Construction shall be carried out with all labour, tools, equipment and incidentals supplied by the Contractor, as necessary, to complete all fencing work in accordance with good work practice.

741.32 Clearing & Grading – All trees (other than any required by the Ministry Representative to remain), all brush and other obstacles which interfere with the construction and maintenance of fencing and not removed by the normal clearing operations, shall be removed prior to commencing fencing work so that both sides of the fence line are free of all clearing and grubbing debris.

Minor ground undulations shall be corrected to obtain a smooth uniform grade, but appreciable grade depressions may be backfilled only with the permission of the Ministry

Representative.

The site shall be left in a smooth and tidy condition.

741.33 Setting Out and Connections to Existing – Fence line, as shown on the Drawings, generally will be along the right-of-way boundary. Where undergrowth clearing is carried out to the right-of-way boundary, the fence line will be offset 0.5 m in from the boundary.

Post installation in fill material or minimum overburden shall be carried out to the Ministry Representative's directions. Where it is not possible to drive or set wood posts to proper depth or to relocate same along the fence line, steel fence posts as specified or, where permitted, multiple wood post and brace assemblies shall be substituted.

Existing cross fences shall be connected to new with posts and braces for tensioning fencing wire in every direction in accordance with Drawings SP741-01.03 and SP741-02.02.

741.34 Standard Wire Type A, B & C Fences and Gates

741.34.01 Post Installation – Fence posts shall be driven in place with equipment acceptable to the Ministry Representative, set in augered pilot holes or, where permitted by the Ministry Representative, set in dug holes with necessary well tamped backfill for a firm installation and post penetration to at least the depth indicated on Drawings SP741-01.01 and SP741-02.01.

On straight alignments all posts shall be plumb. On appreciable grades, posts shall be installed perpendicular to the slope.

On curved alignments, the posts shall be set 50 mm off plumb away from the curve centre, with a post spacing in accordance with Drawing SP741-04.02 and increased post lengths and bury depth for post stability where necessary.

Gate post sizes and stabilizing shall be as required by the Special Provisions and/or Drawing SP741-04.04.

Steel fence posts, as specified by SS 316.09, are required on exposed rock or rock with "minimum overburden" (as defined on Drawing SP741-04.01) and shall be driven and/or wedged to the full depth in a vertical drilled hole of minimum diameter or set plumb and rigid in cement and sand or fine aggregate mortar all as indicated by Drawing SP741-04.01.

Note: Assemblies of securely wire tied multiple wood posts/braces may be specified or permitted by the Ministry Representative especially for minor rock outcropping and unforeseen minimum overburden occurrences.

When full bury depth of wood posts is not attainable, the specified steel fence posts shall be used to the full penetration into rock, all as indicated on Drawing SP741-04.01.

Tops of all posts shall be set to a uniform 50 mm above the level of the top wire of fencing and, where necessary, cut to

line-up in vertical uniformity after inspection by the Ministry Representative. Wood post tops where cut, shall be bevelled and preservative treated in two heavy applications.

Wood posts which are burred, split or otherwise damaged from the installation, and which are not acceptable to the Ministry Representative shall be replaced at the Contractor's expense.

741.34.02 Bracing for Fence Tensioning – Braces of treated wood and twisted galvanized diagonal wire shall be installed between end posts and adjoining panel posts to stabilize the tensioning of the fencing fabric and/or barbed wire, all as indicated by Drawings SP741-01.03 and SP741-02.03. Corner and intersection assemblies shall be similarly tensioned in each fence direction.

Intermediate tensioning assemblies shall be provided within the maximum spacings indicated on Drawings SP741-01.02 and SP741-02.02 to make use of rolls of fabric etc. of standard length with a minimum of cutting and waste.

Steel corner, intersection and intermediate tensioning assemblies with steel angle posts and diagonal bracing are indicated on Drawing SP741-04.01.

Horizontal alignment changes over 30° with wood posts and over 15° with steel posts shall be stabilized as for corners above. Where a change is less than 30° with wood posts, a pair of line posts, set 2.4 m or 3.0 m apart, shall be stabilized with a horizontal wood brace and diagonal wire bracing both ways. For a change of less than 15° with steel posts, a steel line post at the change shall be stabilized in both directions with diagonal steel braces to adjoining line posts as indicated on Drawing SP741-04.01.

Similar requirements shall be maintained at each change to or within any curved fence alignment where the closer post spacing indicated by Drawing SP741-04.02 is not considered adequate.

Note: The previous requirements for alignment changes may be waived by the Ministry Representative wherever, from consideration of the soil conditions, the Ministry Representative directs that the stability and strength of the fence is not likely to be appreciably lessened by such change of alignment.

Vertical alignment changes shall be stabilized, and fence requirements at ditch and gully conditions shall be as called for by Drawing SP741-04.03 or as the Ministry Representative may direct.

741.34.03 Fabric and Wire – Fence fabric shall normally be installed on the side of the posts away from the highway, stretched between end type assemblies and intermediate tensioning assemblies with proper equipment (tensioning directly by truck or tractor will not normally be permitted) and securely stapled in accordance with good practice to wood posts, as indicated by Drawing SP741-01.01, or securely wired or clipped to steel posts to permit free wire

movement on line posts. Similarly, barbed wire shall be installed so as to allow it to "prestretch" before final tensioning, and shall be securely stapled to tensioning assemblies.

For fencing on a curve requiring the fabric and/or barbed wire on the highway side of the posts, all line wires shall be double stapled and the top wire shall be securely wire tied to posts in addition where the adjoining property has livestock.

Barbed wire Type C fences shall normally have wood droppers "interwoven" and securely figure-of-eight wire tied to every line wire, as indicated by Drawing SP741-02.01. Alternatively, proprietary galvanized sheet metal prefabricated droppers of pre-approved design for secure clip-on application may be approved.

Note: High livestock pressures may warrant Type C1 fencing and nursery livestock enclosures Type C1 or B fencing. Where such fences, 1200 mm and higher, are in wildlife sensitive areas, the top strand may be specified smooth (barbless) as Type C2 or B1 fences.

741.34.04 Gates – Hardware, of design to permit the gate to operate correctly, shall be securely attached to prevent the easy removal of the gate and hardware. Hinges shall be installed to permit the gate to swing back one-way against the fence. Locking hardware shall be of the type specified.

741.35 High-tensile Smooth-wire Fences – For rangeland and other locations with favourable terrain, soil conditions and fence alignment at the locations indicated on Drawings, construct high-tensile smooth-wire fencing between rigid end, gates, corner and any necessary intermediate tensioning assemblies in general accordance with Drawings SP741-03.01 through SP741-03.03.

741.35.01 Fence Style – Fence style for wildlife crossing areas shall comprise 5 wires, the bottom wire for installation at 250 mm ± 50 mm above grade at and between posts, the next two wires at 200 mm spacing and the top two 225 mm for a total height of 1100 mm, as indicated by Drawing SP741-03.01 for HT Fences. Elsewhere, and for nursery livestock enclosures and other areas of high livestock pressure, a 6-wire fence may be specified, having the bottom wire 200 mm ± 50 mm above grade at and between posts with the remaining wires at 200 mm spacing for a total height of 1200 mm indicated as HT-1 Fences.

741.35.02 Post and Brace Installation – Fence posts shall be driven in place with equipment acceptable to the Ministry Representative and set out in general accordance with the recommendations of the B.C. Ministry of Agriculture and Food (BCMAF) Publication #ISBN 0-7719-9824-4, good local trade practice and to the Ministry Representative's direction.

Terminal (end and gate) tensioning assemblies and any intermediate assemblies shall be "single" assemblies and at the spacings and post bury depths indicated by Drawing SP741-03.02 (or such greater depths and/or decreased

spacings as may be directed by Ministry Representative) with "double" assemblies used with scant bury depths all to form rigid, stable and accurately aligned assemblies for tensioning line wires.

Line posts 100 mm minimum diameter driven to a depth of not less than 650 mm in firm soil, or as otherwise required by Drawing SP741-03.01, or directed, shall be spaced up to a maximum of 15 m where permitted, but normally at 10 m spacing and such closer spacing at changes in horizontal and vertical alignments to keep the bottom wire at the regular specified ground clearance.

741.35.03 Wire and Dropper Installation – Wires shall be installed on the side of the fence posts away from the highway except on such curves requiring the wires on the highway side so as to bear on the posts.

Stapling doubled at curves, etc. and mechanical fasteners at tied-off ends and splices (where permitted) shall be to BCMAF recommended practice.

With supplied tensioning devices installed in each line, all wires shall be individually tensioned in stages and after "wire-set" to 1.33 kN (300 lbs) at completion.

Droppers, as supplied, shall be installed and securely clipped to all line wires at 3 to 4 m spacing.

741.36 Chain Link Type D Fences and Gates

741.36.01 Post and Rail Installation

i) All terminal posts (posts at ends, gates, corners and intersections), all line posts and any intermediate tensioning posts shall be set plumb into concrete footings in augered or dug holes to the depths and regular spacing all as shown on Drawing SP741-05.01, or as otherwise specified or directed.

ii) Gate post sizes and stabilizing shall be as required by the Special Provisions and/or Drawing SP741-05.03.

iii) On exposed rock, posts shall be set without concrete footings to full depth and fully grouted in holes, 25 mm greater than the pipe diameter, drilled to a depth into solid rock of half the depth of pipe bury to that indicated for concrete footings on Drawing SP741-05.01 (i.e. c/2 and f/2).

Grout shall be non-shrink cement and sand mortar. Standard length posts may be used where the overburden depth is such that the depth of bury into solid rock is less than that specified above, provided normal diameter concrete footings of the diameter indicated on Drawing SP741-05.01 are formed from solid rock to grade level. Similarly, form concrete footings for posts set in loose or friable rock. Sleeves shall be provided to form holes similar in diameter and depth to above for casting into concrete where shown or specified.

iv) Tops of all posts shall be set or cut for an even height of top rail, which shall form a continuous brace and mesh support between terminal posts and any intermediate tensioning posts. Top rails shall pass through line post caps and be joined in the length with internal sleeves to allow

expansion and contraction. All posts shall be fitted with appropriate weathertight caps securely fixed.

741.36.02 Bracing for Fence Tensioning – Bottom tension wire shall be securely fixed taut and sag free to terminal posts and any intermediate tensioning posts. Similarly, provide top tension wire, when specified, in place of top rail to pass through line post tops except on uneven terrain where the height of the top tension wire shall be such that it is secured to all line posts and the mesh within the top 300 mm of the mesh.

Terminal posts, where more than 10 m apart in any fence run, shall have horizontal pipe braces to adjoining line posts. Diagonal pipe braces may be called for where soil conditions warrant, especially where fencing without top rails is specified, but no pipe bracing is normally required for residential height fences.

Intermediate tensioning assemblies shall be provided where terminal posts are more than 150 m apart, and at any subsequent 150 m maximum spacing, to consist of a straining post (to full height of fence where barbed wire on extension arms is specified) with horizontal pipe braces at the mid to two-thirds height above grade to adjoining line posts each way for the discontinuity of top rail, tension and/or barbed wire and mesh; provide similar tensioning assembly at abrupt vertical alignment changes.

Horizontal alignment changes where abrupt shall be considered as corners.

At changes in horizontal alignment and to curved fence alignments, where the top rail can be continuous by accurately bending to proper curvature without damage to the galvanized coating, a pair of line posts shall be stabilized and tensioned as follows:

- A horizontal pipe brace shall be securely fixed to adjoining line posts at the two-thirds height above grade.
- Crossed diagonal wire braces shall each be two strands of 3.5 mm nominal diameter galvanized wire securely fixed to the brace band fixing of the horizontal brace and to a brace band 100 mm above grade.
- Each pair of wires shall be twisted taut to mutually stabilize the assembly with the tensioning battens left in place.

Similar requirements shall be maintained within any curved fence alignment over 30 m in length.

Note: The previous requirements may be waived by the Ministry Representative wherever the Ministry Representative directs that, from consideration of the soil conditions and footing sizes, especially where with continuous top rail, the stability and strength of the fence is not likely to be appreciably lessened by the change in alignment.

Fencing where continuous over a creek or ditch shall be stabilized with a horizontal pipe brace and diagonal brace

wires as specified above, and the bottom tension wire shall be wire tied to a similar pipe brace. In addition, in-fill under where specified or required, shall be a hanging or rigidly fixed bent pipe of brace diameter hung or in-filled with closely spaced barbed wire or suitable fence fabric (similar to that indicated on Drawing SP741-04.03), all to the Ministry Representative's direction.

741.36.03 Fabric and Wire – Chain link fencing mesh shall be stretched between terminal posts and any intermediate tensioning posts with proper equipment (tensioning directly by truck or tractor will not normally be permitted), and secured with tension bars and bands, tie wire and clips all in accordance with the requirements shown on Drawing SP741.05.02. The mesh shall be installed on the highway side of the fence posts, or as otherwise specified or directed, and joints in the length shall be made by weaving the meshes together with a single wire picket to form a neat continuous fabric mesh.

Security barbed wire, where specified, shall be installed in the slots of all extension arms and secured to extended height terminal and any intermediate tensioning posts taut and free of sag.

741.36.04 Gates – Hardware, of design to permit the gate to operate correctly, shall be securely attached to prevent the easy removal of the gate and hardware. Hinged gates shall be installed to permit the gate to swing back one-way against the fence.

741.37 Wood Fences

741.37.01 Privacy Fences – Galvanized pipe posts shall be set plumb in concrete footings in augered or dug holes to the depth and regular spacing all as shown on Drawing SP741-06.02.

Wood fixing members for fence panels shall be securely nailed, "II-shaped" frames fixed and supported with 9.5 mm (3/8") galvanized bolts and nuts to pipe posts all as indicated on Drawing SP741-06.01.

Metal fixing members for fence panels, when specified, shall be of named or otherwise pre-approved proprietary brand or detailed formed metal channel and strap, bolted on around pipe posts and securely machine screwed and tapped at the correct levels all as indicated on Drawing SP741-06.03.

Fence panels of boards and stringers prestained, as specified, shall be prefabricated to the required design, as indicated by the Contract Drawings, Special Provisions and/or Drawings SP741-06.01 through SP741-06.03, and shall be accurately fitted and securely nailed to fixing members on steel posts to form uniformly level and/or stepped fencing.

741.37.02 Noise Barrier Fences – Posts of indicated type, size and length shall be set plumb in concrete footings in

augered or dug holes to the depth and regular spacing all as shown on the Contract Drawings.

Stringers, to bear full width of post at each end of "alternating" or "zig zag" (on plan) panels, shall be securely bolted with large washers behind head and nut.

Planking shall be firmly secured to stringers with deformed shank nails to form close butted and battened or tightly overlapped vertical planked panels. All gaps, especially at bottom, shall not exceed 1% of the total area of the fencing. Ends of panels shall be closed over the gap between stringer and post with return plank material.

741.38 Steel Sidewalk Fencing – Steel sidewalk fence and bicyclist sidewalk fencing shall be installed in accordance with Drawings SP741-07.01, SP741-07.02 and SP741-07.03 as applicable.

Note: These are guide fences only, not intended for use adjacent to drop-offs or high slopes.

MEASUREMENT

741.81 Fencing – Fencing will be measured by the LINEAL METRE. Measurements will be made parallel to the ground line of complete fencing, including any tensioning assemblies, but excluding gate openings.

741.82 Gates and Cattleguards – Gates and cattleguards will be measured by the unit for EACH type and size furnished and/or installed complete in place.

PAYMENT

741.91 Fencing – Payment for FENCING will be at the Contract Unit Price per metre of complete fencing, including any tensioning assemblies, but excluding gate openings.

The Contract Unit Price(s) shall be accepted as full compensation for furnishing all material and/or taking delivery of Ministry supplied material; as and where noted, all labour, tools, equipment and incidentals to complete the required installation, including the clearing of any additional right of way, construction of temporary fencing, connection to existing fences and structures, and final clean up; but excluding any work as may be required to be separately paid for, such as the extra cost of extensive fencing on rock at the contract or agreed price for each hole drilled for metal posts.

741.92 Gates and Cattleguards – Payment for GATES and CATTLEGUARDS will be at the Contract Unit Price for each type and size furnished and/or installed complete in place.

741.93 Steel Sidewalk Fencing – Payment for steel sidewalk fence and bicyclist sidewalk fencing will be at the Contract Unit Price per metre of complete fencing.

TYPE A, B & B1 STANDARD WIRE FENCE

SP741-01.01

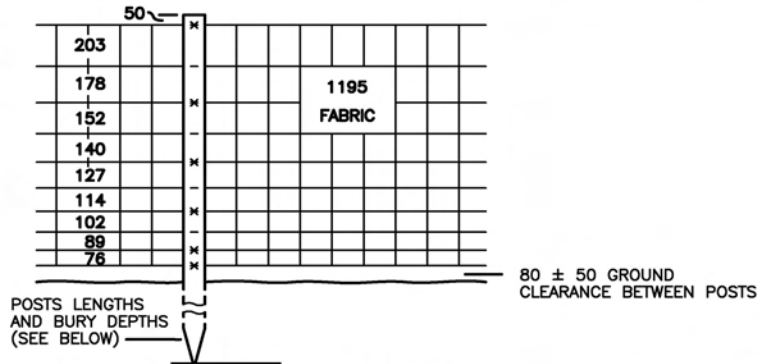

TYPE 'A' FENCE 10476
(RAILWAY RIGHT OF WAY)

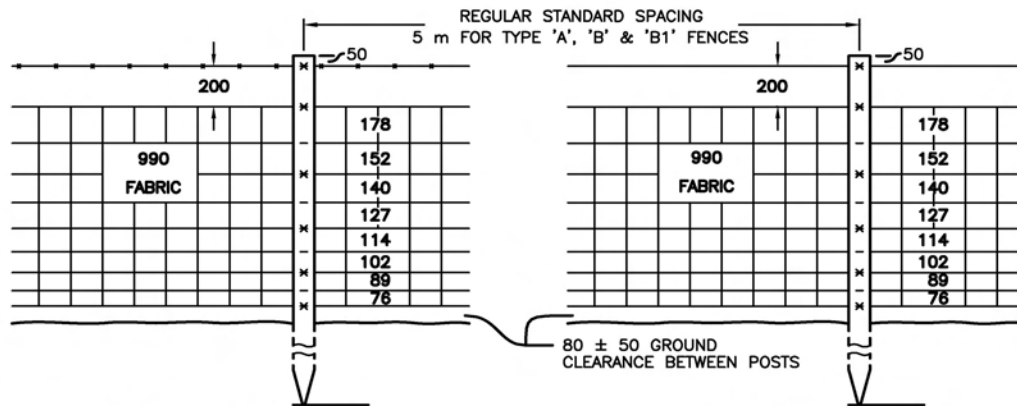

* **TYPE 'B' FENCE 9396**
(HIGHWAY)

TYPE 'B1' FENCE 9396
(HIGHWAY - WILD-LIFE SENSITIVE AREAS)

* USE OF TYPE 'B' FENCE REQUIRES A REVIEW BY THE CHIEF ENVIRONMENTAL OFFICER AND WRITTEN APPROVAL MUST BE RECEIVED PRIOR TO INSTALLATION.

NOTES:

1. FENCE CONSTRUCTION SHALL BE IN ACCORDANCE WITH SECTION 741 OR AS OTHERWISE SPECIFIED OR REQUIRED.
2. PRESSURE TREATED WOOD POST AND BRACE MATERIAL AS SPECIFIED IN SECTION 909.
3. DOUBLE STRANDED GALVANIZED BARBED WIRE AS SPECIFIED BY ASTM A 121 AND SUBSECTION 316.06 FOR TYPE 'B' FENCE.
4. SINGLE STRAND HIGH-TENSILE WIRE AS SPECIFIED IN SUBSECTION 316.07 FOR TYPE 'B1' FENCE.
5. WIRE FABRIC AS SPECIFIED BY ASTM A 116 AND SUBSECTION 316.03.
6. TYPE 'A' - HEAVY FARM-FIELD GALVANIZED WIRE FABRIC 1195 mm HIGH STYLE 10.47.6.
7. TYPE 'B' - HEAVY FARM-FIELD GALVANIZED WIRE FABRIC 990 mm HIGH STYLE 9.39.6.
8. STAPLES: 45 mm LONG OF 3.5 mm NOMINAL DIAMETER GALVANIZED WIRE TO EVERY LINE OF BARBED AND SMOOTH WIRE AND ALTERNATE LINE WIRE OF FABRIC FENCING AS INDICATED.
9. LINE POSTS: 100 mm MINIMUM DIAMETER, POINTED FOR DRIVING, SET PLUMB AND FIRM.

BURY DEPTH (mm)	POST LENGTH (m)
STANDARD 850	2.2
PEAT SOIL 1050	2.4

NOTE: ROCK, SHALE AND FRIABLE ROCK CONDITIONS WARRANT METAL POSTS - SEE SP741-04.01 FOR MINOR ROCK OUTCROPPINGS AND UNFORESEEN MINIMUM OVERBURDEN OCCURENCES, WIRE TIED MULTIPLE WOOD POST/BRACE ASSEMBLIES MAY BE PERMITTED BY THE MINISTRY REPRESENTATIVE.

NOT TO SCALE

ALL DIMENSIONS ARE IN MILLIMETRES UNLESS OTHERWISE NOTED

TYPE A, B & B1 FENCE STABILIZATION REQUIREMENTS

SP741-01.02

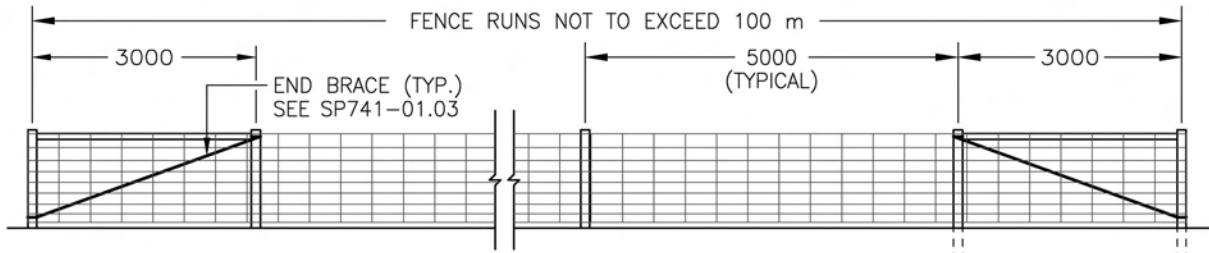

END CONDITIONS

(CORNER AND INTERSECTION ASSEMBLIES SIMILAR)

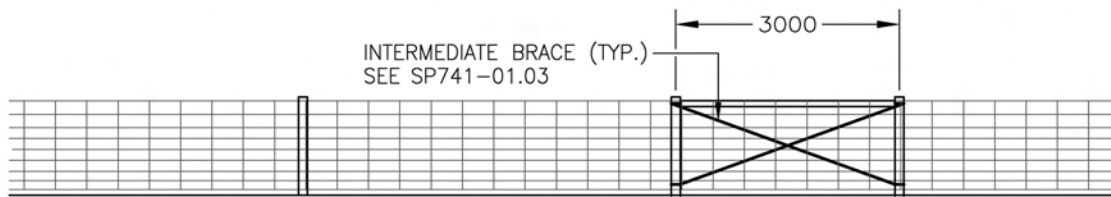

BRACE PANEL(S)

(INTERMEDIATE TENSIONING
AT NOT EXCEEDING 100 m SPACING)

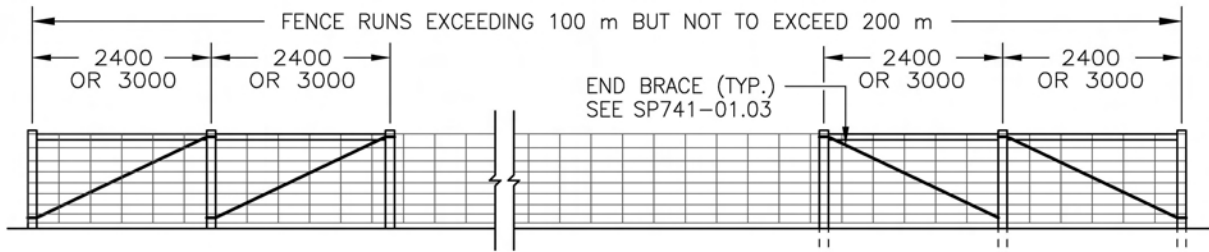

ALTERNATIVE

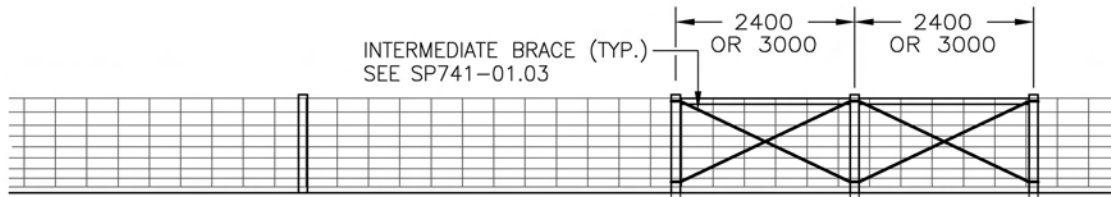

STRAINING PANEL(S)

(INTERMEDIATE TENSIONING
AT NOT EXCEEDING 200 m SPACING)

NOT TO SCALE

ALL DIMENSIONS ARE IN MILLIMETRES UNLESS OTHERWISE NOTED

TYPE A, B & B1 FENCE STABILIZATION REQUIREMENTS

SP741-01.03

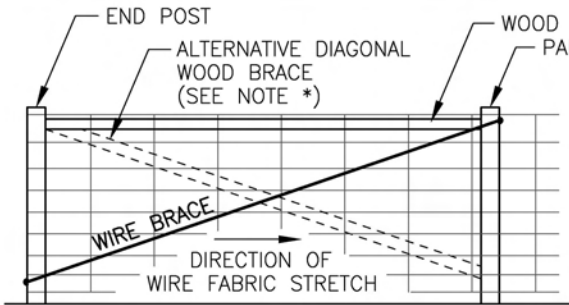

END BRACE
(BASIC END TENSIONING PANEL)

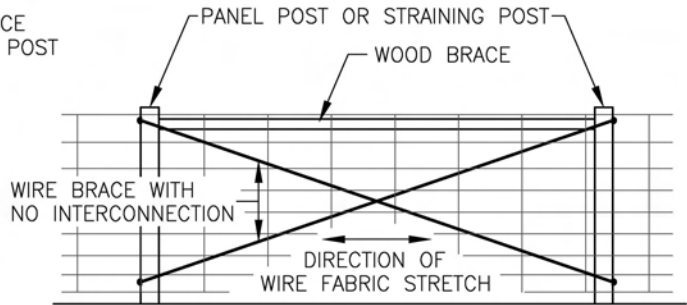

INTERMEDIATE BRACE
(BASIC INTERMEDIATE TENSIONING PANEL)

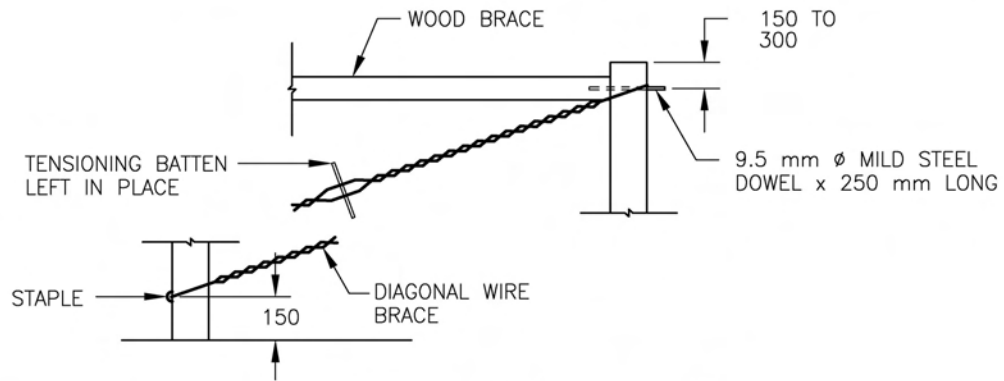

WOOD AND WIRE BRACE DETAIL

GENERAL NOTES:

WIRE FABRIC ROLL LENGTH 100 m.

STRAINING PANELS AND/OR BRACE PANELS ARE REQUIRED FOR TENSIONING FABRIC AND AT SIGNIFICANT CHANGES IN FENCE ALIGNMENT.

POST SIZES: ALL POSTS - 120 mm (MIN.) DIAMETER EXCEPT:
 LINE POSTS - 100 mm (MIN.) DIAMETER
 CORNER POSTS - 140 mm (MIN.) DIAMETER

POST LENGTH: ALL POSTS TO BE THE SPECIFIED LINE POST LENGTH
 (EXCEPT LINE POSTS AND GATE POSTS) (SEE SP741-01.01) PLUS 400mm FOR THE STABILIZING INCREASED DEPTH OF BURY.

BURY DEPTH: DEPTH OF END AND PANEL POSTS NORMALLY NOT LESS THAN 1200 mm. WHERE 1200 mm NOT ATTAINABLE BUT EXCEEDING 900 mm, USE DOUBLE TENSIONING STRAINING PANEL ASSEMBLIES AT NOT EXCEEDING 200 m SPACING. GREATER MINIMUMS ARE REQUIRED FOR PEAT SOILS, ETC.

POST SPACING AND WOOD BRACES:

WOOD BRACE	SIZE	LENGTH	POST SPACING APPROXIMATE
HORIZONTAL	80 mm	2.4 m	2.5 m
HORIZONTAL	100 mm	3.0 m	3.1 m
* DIAGONAL	100 mm	3.0 m	2.9 m

* NOTE: SOFT, MARSH AND/OR PEAT SOIL CONDITIONS MAY WARRANT DIAGONAL WOOD BRACES IN PLACE OF HORIZONTALS IN ADDITION TO THE LONGER POSTS.

NOTE: ROCK, SHALE OR FRIABLE ROCK CONDITIONS SEE SP741-04.01 FOR METAL POSTS AND BRACES.

WIRE BRACES: 2 STRANDS OF 3.5 mm NOMINAL DIAMETER GALVANIZED WIRE WITH LOOPED ENDS AROUND DOWEL AND STAPLED TO POSTS - TWISTED TAUT ONE WAY OR BOTH WAYS AS INDICATED

NOT TO SCALE

ALL DIMENSIONS ARE IN MILLIMETRES UNLESS OTHERWISE NOTED

TYPE C, C1, & C2 STANDARD WIRE FENCE

SP741-02.01

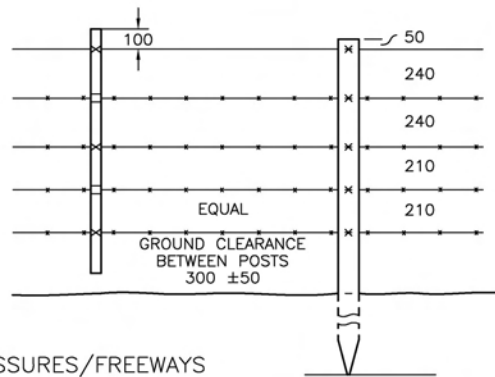
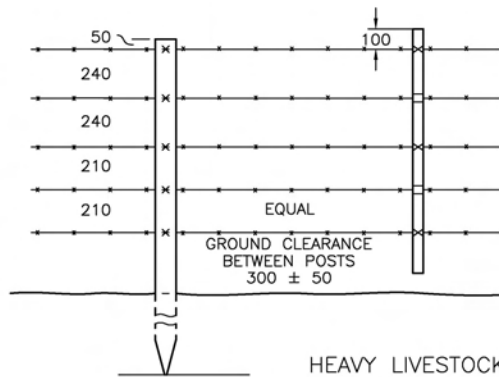
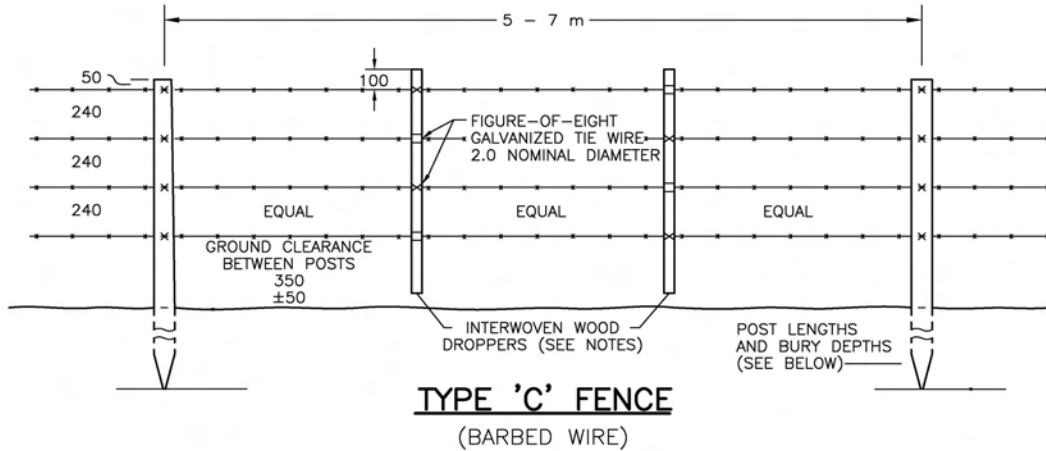

NOTES:

1. FENCE CONSTRUCTION SHALL BE IN ACCORDANCE WITH SECTION 741 OR AS OTHERWISE SPECIFIED OR REQUIRED.
2. PRESSURE TREATED WOOD POST AND BRACE MATERIAL AS SPECIFIED IN SECTION 909.
3. DOUBLE STRANDED GALVANIZED BARBED WIRE AS SPECIFIED BY ASTM A 121 AND SUBSECTION 316.06 FOR TYPE 'C' & 'C1' FENCE.
4. SINGLE STRAND HIGH-TENSILE WIRE AS SPECIFIED IN SUBSECTION 316.07 FOR TYPE 'C2' FENCE.
5. STAPLES: 45 mm LONG OF 3.5 mm NOMINAL DIAMETER GALVANIZED WIRE TO EVERY LINE OF BARBED AND SMOOTH WIRE.
6. DROPPERS: WOOD 50 mm DIAMETER OR OTHER ALTERNATIVE SPECIFIED BY SUBSECTION 909.08.
7. LINE POSTS: 100 mm MINIMUM DIAMETER POINTED FOR DRIVING SET PLUMB AND FIRM.

BURY DEPTH (mm)	POST LENGTH (m)	
	TYPE 'C'	TYPE 'C1' & 'C2'
STANDARD 850	2.0	2.1
PEAT SOIL 1050	2.2	2.3

NOTE: ROCK, SHALE AND FRIABLE ROCK CONDITIONS WARRANT METAL POSTS - SEE SP741-04.01. FOR MINOR ROCK OUTCROPPINGS AND UNFORSEEN MINIMUM OVERBURDEN OCCURRENCES, WIRE TIED MULTIPLE WOOD POST/BRACE ASSEMBLIES MAY BE PERMITTED BY THE MINISTRY REPRESENTATIVE.

NOT TO SCALE

ALL DIMENSIONS ARE IN MILLIMETRES UNLESS OTHERWISE NOTED

TYPE C, C1 & C2 FENCE STABILIZATION REQUIREMENTS

SP741-02.02

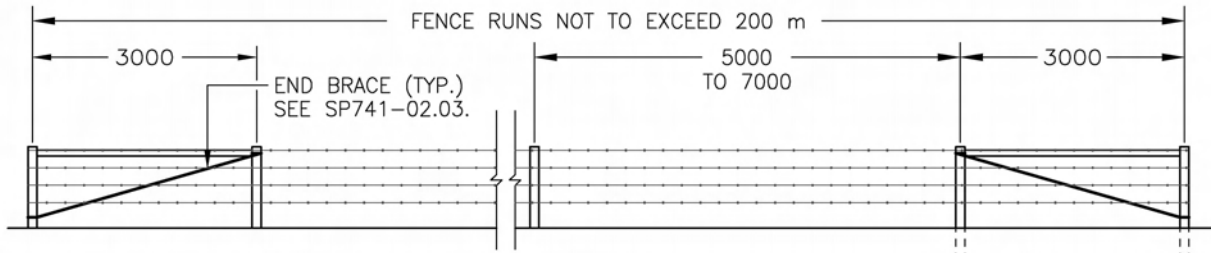

END CONDITIONS

(CORNER AND INTERSECTION ASSEMBLIES SIMILAR)

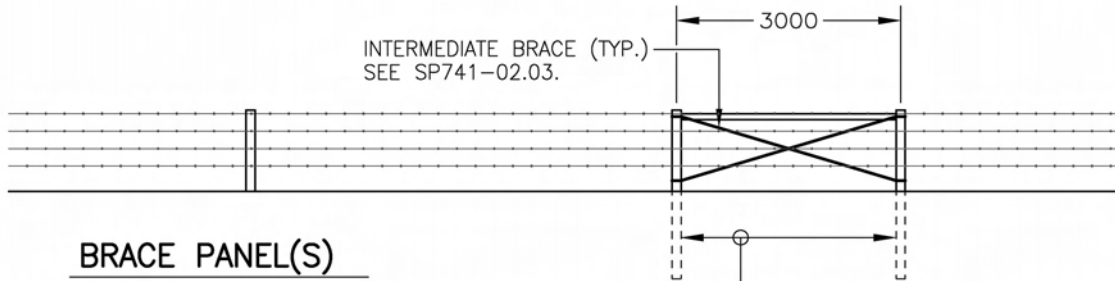

BRACE PANEL(S)

(INTERMEDIATE TENSIONING AT NOT EXCEEDING 200 m SPACING)

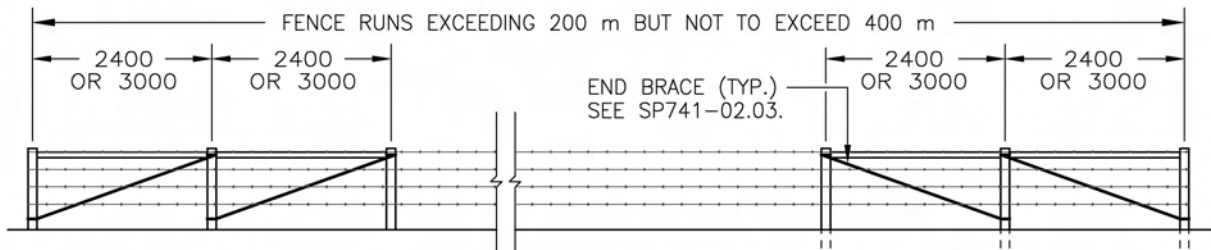

ALTERNATIVE

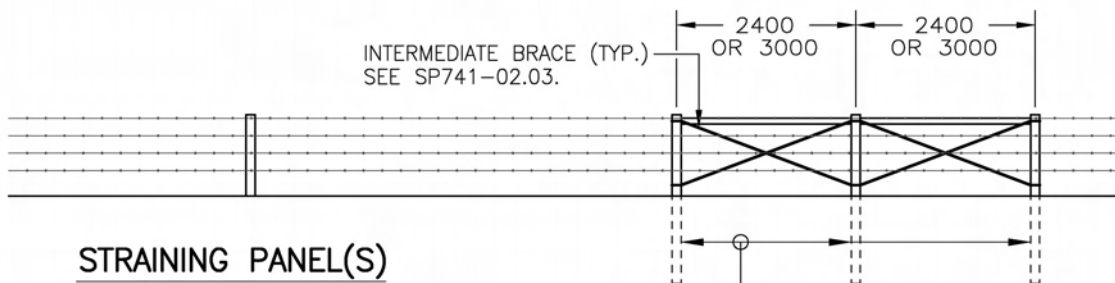

STRAINING PANEL(S)

(INTERMEDIATE TENSIONING AT NOT EXCEEDING 400 m SPACING)

NOT TO SCALE

ALL DIMENSIONS ARE IN MILLIMETRES UNLESS OTHERWISE NOTED

TYPE C, C1 & C2 FENCE STABILIZATION REQUIREMENTS SP741-02.03

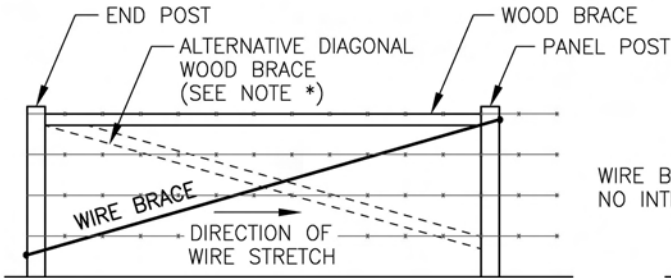

END BRACE
(BASIC END TENSIONING PANEL)

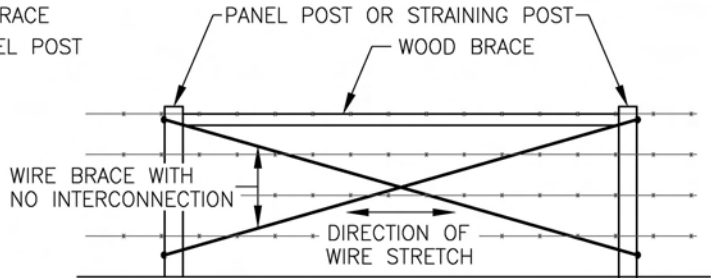

INTERMEDIATE BRACE
(BASIC INTERMEDIATE TENSIONING PANEL)

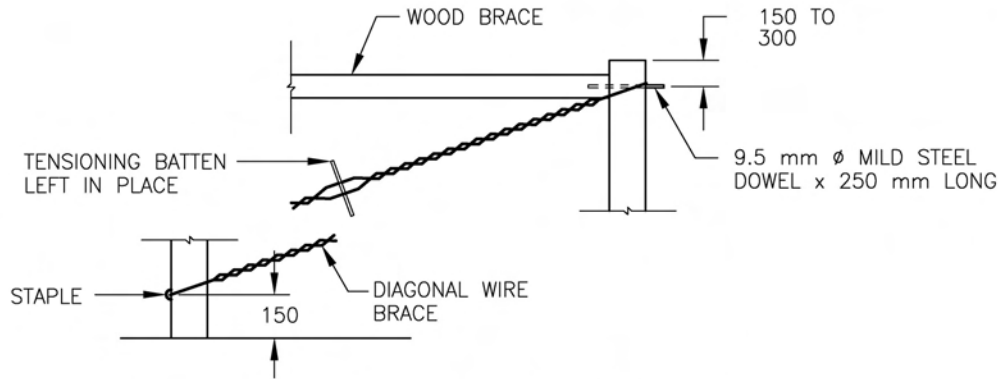

WOOD AND WIRE BRACE DETAIL

GENERAL NOTES:
BARBED WIRE SPOOL LENGTH 400 m.

STRAINING PANELS AND/OR BRACE PANELS ARE REQUIRED FOR TENSIONING WIRE AND AT SIGNIFICANT CHANGES IN FENCE ALIGNMENT.

POST SIZES: ALL POSTS - 120 mm (MIN.) DIAMETER EXCEPT:
LINE POSTS - 100 mm (MIN.) DIAMETER
CORNER POSTS - 140 mm (MIN.) DIAMETER

POST LENGTH: ALL POSTS TO BE THE SPECIFIED LINE POST LENGTH (SEE SP741-01.01) PLUS 400 mm FOR THE STABILIZING INCREASED DEPTH OF BURY.

BURY DEPTH: DEPTH OF END AND PANEL POSTS NORMALLY NOT LESS THAN 1200 mm. WHERE 1200 mm NOT ATTAINABLE BUT EXCEEDING 900 mm, USE DOUBLE TENSIONING STRAINING PANEL ASSEMBLIES AT NOT EXCEEDING 200 m SPACING. GREATER MINIMUMS ARE REQUIRED FOR PEAT SOILS, ETC.

POST SPACING AND WOOD BRACES:

WOOD BRACE	SIZE	LENGTH	POST SPACING APPROXIMATE
HORIZONTAL	80 mm	2.4 m	2.5 m
HORIZONTAL	100 mm	3.0 m	3.1 m
* DIAGONAL	100 mm	3.0 m	2.9 m

* NOTE: SOFT, MARSH AND/OR PEAT SOIL CONDITIONS MAY WARRANT DIAGONAL WOOD BRACES IN PLACE OF HORIZONTALS IN ADDITION TO THE LONGER POSTS.

NOTE: ROCK, SHALE OR FRIABLE ROCK CONDITIONS SEE SP741-04.01 FOR METAL POSTS AND BRACES.

WIRE BRACES: 2 STRANDS OF 3.5 mm NOMINAL DIAMETER GALVANIZED WIRE WITH LOOPED ENDS AROUND DOWEL AND STAPLED TO POSTS - TWISTED TAUT ONE WAY OR BOTH WAYS AS INDICATED ABOVE.

NOT TO SCALE

ALL DIMENSIONS ARE IN MILLIMETRES UNLESS OTHERWISE NOTED

HIGH-TENSILE FENCES (SMOOTH WIRE & WOOD POSTS)

SP741-03.01

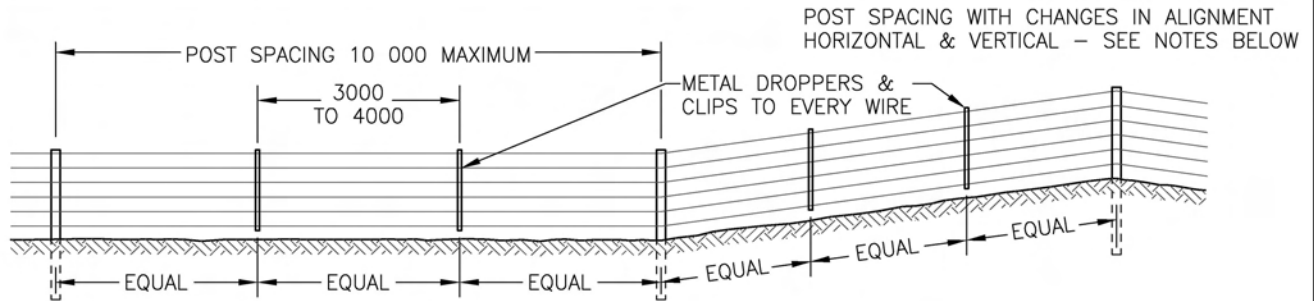

HIGH-TENSILE SMOOTH-WIRE FENCING

FOR RANGE LAND AND OTHER LOCATIONS WITH FAVOURABLE TERRAIN, SOIL CONDITIONS AND FENCE ALIGNMENT.

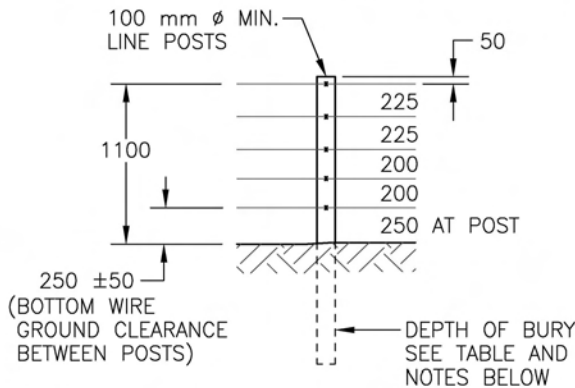

POST SPACING: 10 m MAX. (HIGH SNOW AREAS 7 m MAX.)

	DEPTH OF BURY	POST LENGTH
FIRM SOIL	650 mm	1.8 m
MEDIUM CLAY	850 mm	2.0 m
PEAT SOIL	1050 mm	2.2 m

TYPE HT FENCE

RANGELAND AND WILD LIFE SENSITIVE AREAS

NOTE: REDUCE LINE POST SPACING FOR SUCH AS NURSERY LIVESTOCK ENCLOSURES (HT-1 FENCE) AND AT ALL MINOR HORIZONTAL AND VERTICAL ALIGNMENT CHANGES. SEE SP741-03.03 FOR "SHALLOW", "MEDIUM" CURVES AND CORNER CHANGES IN ALIGNMENT.

GENERAL NOTES:

SETTING OUT AND CONSTRUCTION SHALL BE IN GENERAL ACCORDANCE WITH SECTION 741 AND MINISTRY OF AGRICULTURE AND FOOD PUBLICATION #ISBN 0-7719-9824-4 (BCMAF) PROCEDURES OR AS OTHERWISE REQUIRED.

POST AND BRACES: PRESSURE TREATED WOOD AS SPECIFIED IN SECTION 909.

WIRE: 2.5 mm NOMINAL DIAMETER HIGH-TENSILE GALVANIZED WIRE AS SPECIFIED BY SUBSECTION 316.07.

METAL DROPPERS AND CLIPS, SPLICERS AND FASTENERS & TENSIONING DEVICES. } PROPRIETRY MANUFACTURE TO SUBSECTION 316.12.

STAPLES: 45 mm LONG OF 3.5 mm NOMINAL DIAMETER GALVANIZED WIRE: DOUBLE STAPLE ON CURVES AND RISE AND DIP POSTS TO BCMAF RECOMMENDATIONS.

LINE POSTS: 100 mm MINIMUM DIAMETER SET FIRM BY DRIVING AND SET PLUMB EXCEPT FOR REQUIRED LEAN ON "MINOR" CURVES, SEE POST SIZE AND LENGTH FOR OTHER CURVES ON SP741-03.02 & SP741-03.03.

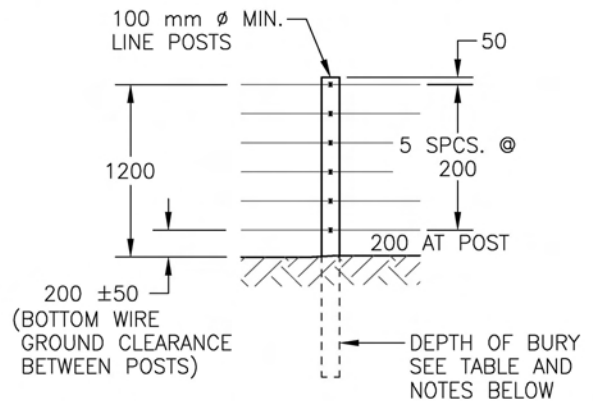

POST SPACING: 7 m MAX.

	DEPTH OF BURY	POST LENGTH
FIRM SOIL	750 mm	2.0 m
MEDIUM CLAY	950 mm	2.2 m
PEAT SOIL	1150 mm	2.4 m

TYPE HT-1 FENCE

HEAVY LIVESTOCK PRESSURES/FREEWAYS (WHERE PERMITTED OR REQUIRED)

NOT TO SCALE

ALL DIMENSIONS ARE IN MILLIMETRES UNLESS OTHERWISE NOTED

HIGH-TENSILE FENCE STABILIZATION

SP741-03.02

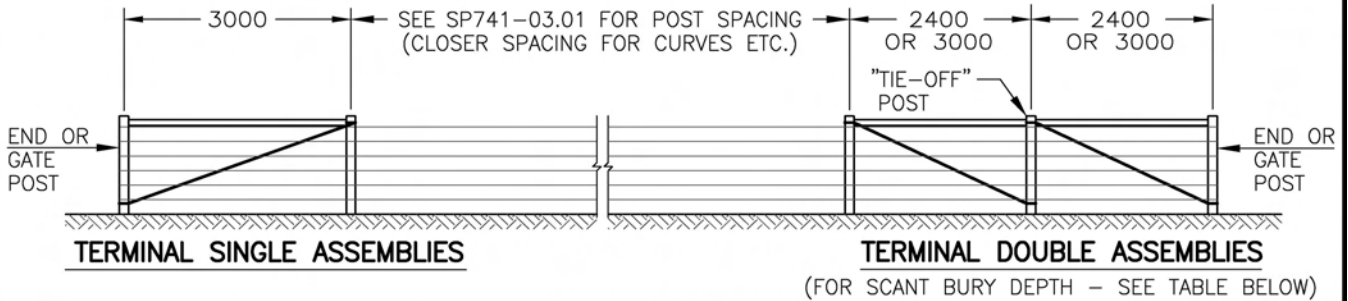

TERMINAL (END AND GATE) TENSIONING ASSEMBLIES

(CORNER AND INTERSECTION ASSEMBLIES SIMILAR)

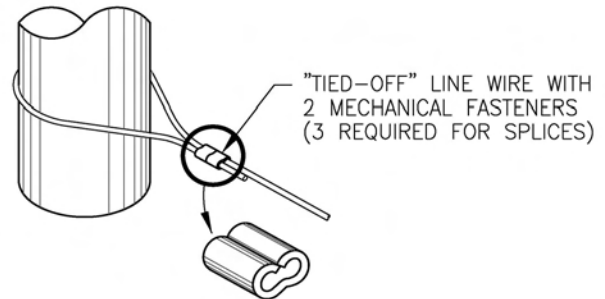
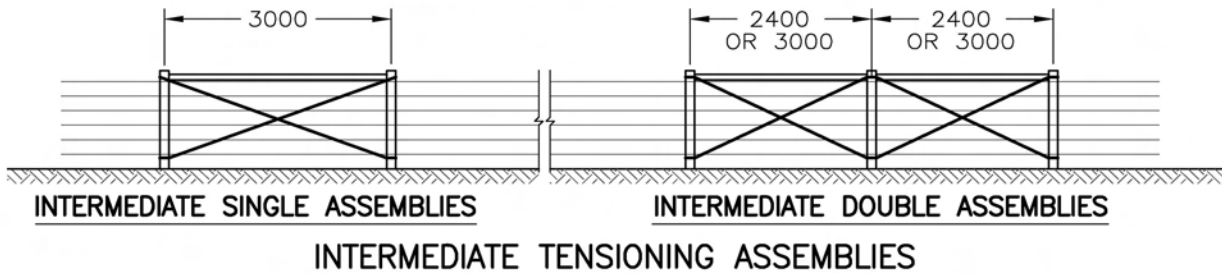

GENERAL NOTES:

COIL OF SMOOTH HIGH-TENSILE WIRE IN EXCESS OF 1000 m (APPROX. 100#)

POST SIZES: ALL 120 mm ϕ MINIMUM EXCEPT
 LINE POSTS 100 mm ϕ MIN., CORNER POSTS 140 mm ϕ
 MINIMUM AND GATE POSTS 190 mm ϕ MINIMUM.
 HORIZONTAL BRACES: 100 mm ϕ MIN., 3.0 m LONG
 (2.4 m LONG PERMITTED WITH DOUBLE ASSEMBLIES).

TERMINAL (END AND GATE) TENSIONING ASSEMBLIES SHALL BE PROVIDED TO TENSION EVERY LINE WIRE. WHERE TERMINAL SPACING IS IN EXCESS OF 1000 m *, INTERSPERSE WITH INTERMEDIATE TENSIONING ASSEMBLIES, UTILIZING ANY REQUIRED INTERSECTION AND CORNER ASSEMBLIES AT NOT EXCEEDING 1000 m * SPACINGS.

* SEE REDUCED SPACING REQUIREMENTS BELOW: NORMALLY 400 TO 600 m BUT MINIMUM 150 m.

FOR CONSTRUCTION OF SINGLE AND DOUBLE ASSEMBLIES SEE SP741-01.02, SP741-01.03, SP741-02.02 & SP741-02.03 BUT USE HIGH TENSILE WIRE FOR WIRE BRACES.

DEPTH OF BURY AND POST LENGTH FOR SINGLE AND DOUBLE ASSEMBLIES.

TYPICAL SOIL TYPE	HT (5 WIRE) FENCE				HT-1 (6 WIRE) FENCE			
	SINGLE		DOUBLE		SINGLE		DOUBLE	
	BURY DEPTH (mm)	LENGTH (m)	BURY DEPTH (mm)	LENGTH (m)	BURY DEPTH (mm)	LENGTH (m)	BURY DEPTH (mm)	LENGTH (m)
FIRM SOIL	1050	2.2	850	2.0	1150	2.4	950	2.2
MEDIUM CLAY	1250	2.4	1050	2.2	1350	2.6	1150	2.4
PEAT SOIL	-	-	1250	2.4	-	-	1350	2.6

REDUCE SPACING OF TENSIONING ASSEMBLIES WHERE ABOVE BURY DEPTHS ARE NOT ADEQUATE FOR THE PARTICULAR SOIL CONDITION AND FOR CHANGES IN HORIZONTAL ALIGNMENT AT CURVES AND UNTIED-OFF CORNERS:

3 m REDUCTION FOR EVERY 1" OF DEFLECTION CHANGE

NOTE: ALL "CURVE" POSTS TO BE 120 mm ϕ MIN. WITH LENGTHS AND BURY AS FOR END POSTS.

REDUCTION OF ASSEMBLY SPACING FOR UNEVEN TERRAIN CHANGE IN VERTICAL ALIGNMENT:

- 50 m PER HUMP AND DIP AND 100 m PER MAJOR HUMP AND DIP.

NOT TO SCALE

ALL DIMENSIONS ARE IN MILLIMETRES UNLESS OTHERWISE NOTED

HIGH-TENSILE FENCE STABILIZATION

SP741-03.03

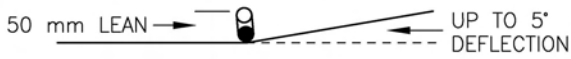

MINOR CURVE

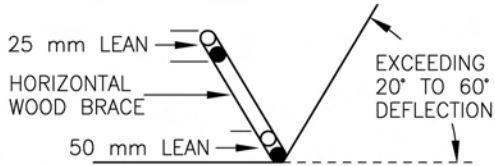

MEDIUM CURVE

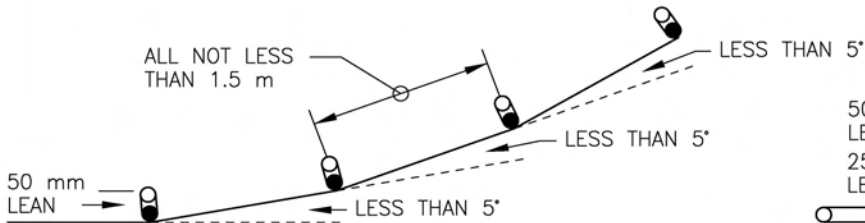
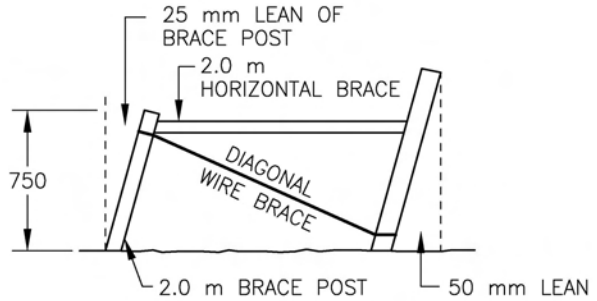

SHALLOW CURVE

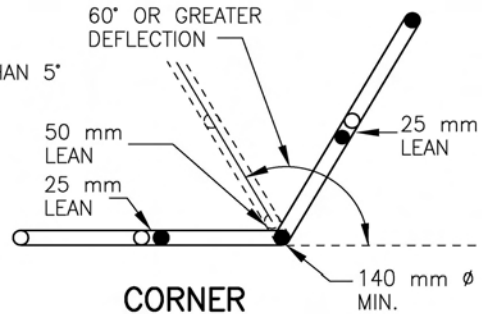

CORNER

NOTE: BRACES ON OUTSIDE OF CURVE WHERE NECESSARY WITH OPPOSITE LEAN AND WIRE BRACE.

TENSIONING DEVICES IN EVERY MECHANICALLY FASTENED "TIED-OFF" LINE WIRE. AT MID-SPAN OR TOWARDS END WITH THE MAJORITY OF ALIGNMENT CHANGES, BETWEEN ADJOINING ASSEMBLIES (FOR STRAIGHT AND LEVEL FENCE RUNS UNDER 200 m: DEVICES NEXT TO ONE TENSIONING ASSEMBLY).

DIP POSTS TO BE PROVIDED WITH STEEL POST(S) OR FOOTING BLOCKS TO BCMAF RECOMMENDATIONS TO RESIST POST LIFTING IN HOLLOW.

DOUBLE STAPLE ALL LINE WIRES AT CURVES, CORNERS, DIPS AND RISES AS INDICATED BELOW AND AS INDICATED * FOR HEAVY SNOW AREAS.



RISE POST



DIP POST



SHALLOW CORNER



RIGHT ANGLE

NOT TO SCALE

ALL DIMENSIONS ARE IN MILLIMETRES UNLESS OTHERWISE NOTED

TYPE A, B, B1, C, C1 & C2 FENCE ON OR OVER ROCK

SP741-04.01

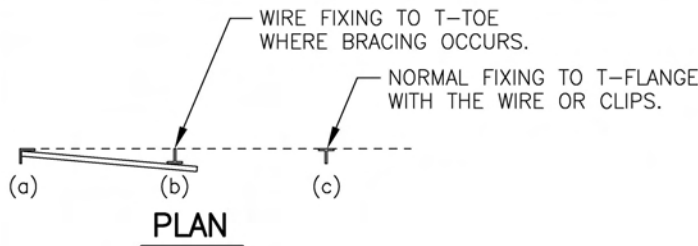

NOTE:
FOR MINOR ROCK OUTCROPPING AND UNFORESEEN MINIMUM OVERBURDEN OCCURRENCES WIRE TIED MULTIPLE WOODPOST/BRACE ASSEMBLIES MAY BE APPROVED BY THE MINISTRY REPRESENTATIVE.

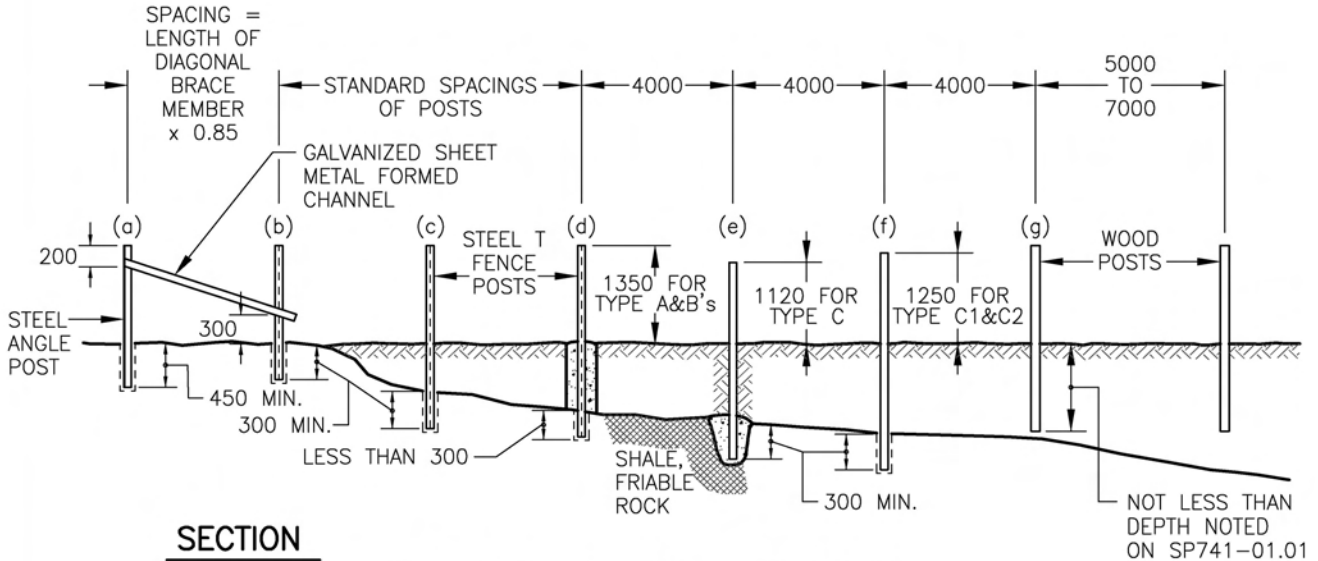

NOTES:

STEEL ANGLE END POST (a) AND SIMILAR CORNER AND INTERSECTION POSTS SET IN CEMENT AND SAND NON-SHRINK MORTAR WITH STEEL BRACE(S) TO ADJOINING STEEL FENCE POST(S) (b) SECURELY AND BOLTED EACH END.

STEEL TEE FENCE POSTS SHALL BE USED ON:

- ROCK (b)
- MINIMUM OVERBURDEN (c) OR (d)
- WITH OVERBURDEN (f) LESS THAN THE NORMAL BURY
- DEPTH FOR WOOD POSTS REQUIRED ON SP741-01.01
- TO SHALE, LOOSE OR FRIABLE ROCK (e)
- ENLARGED DRILLED HOLE SET IN CEMENT MORTAR.

WHERE DEPTH OF BURY OF A STEEL POST INTO SOLID ROCK IS LESS THAN (a) & (b) ABOVE AS AT (d) CONCRETE FOOTING (4:2:1 MIX) OF ADEQUATE SIZE MAY BE APPROVED BY THE MINISTRY REPRESENTATIVE.

CURVED ALIGNMENT SPACING OF STEEL POSTS SEE SP741-04.02.

STEEL ANGLE AND TEE POSTS CHANNEL BRACES ARE SPECIFIED BY SUBSECTION 316.09 AND INSTALLATION BY SUBSECTION 741.34.

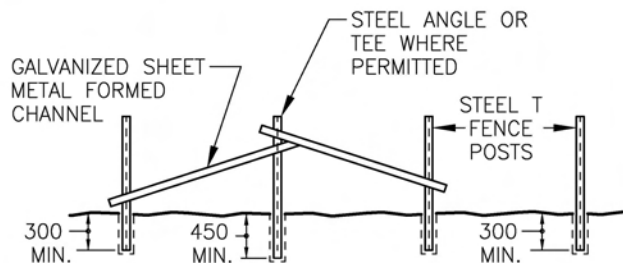
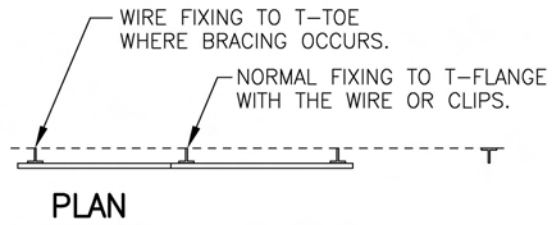

NOT TO SCALE

ALL DIMENSIONS ARE IN MILLIMETRES UNLESS OTHERWISE NOTED

TYPE A, B, B1, C, C1 & C2 FENCE SPECIAL CONDITIONS

SP741-04.02

FENCE POST SPACING (m)

<u>ORDINATE Z (mm)</u>	<u>WOOD POST</u>	<u>STEEL POST</u>
LESS THAN 100	5.0	4.0
GREATER THAN 100 TO 150	4.5	3.6
GREATER THAN 150 TO 200	4.0	3.2
GREATER THAN 200 TO 350	3.2	2.6
GREATER THAN 350	2.4	2.0

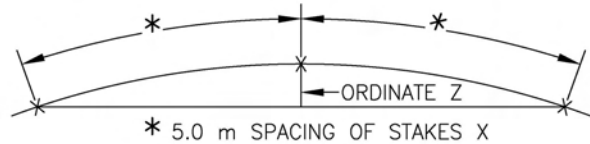

CURVED HORIZONTAL ALIGNMENTS

REDUCED LINE POST SPACING

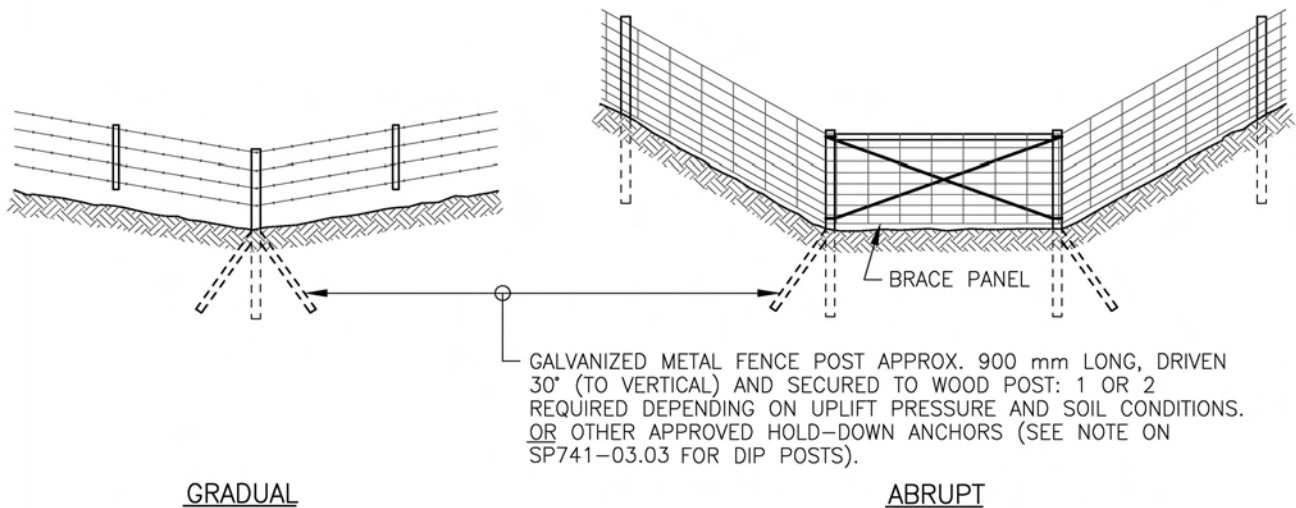

GRADUAL

ABRUPT

NOTES

1. BRACE PANELS OR STRAINING PANELS, (SEE SP741-01.03 & SP741-02.03) ARE REQUIRED ON EITHER SIDE OF AN ABRUPT DEPRESSION TO RELIEVE FENCING TENSION AND MINIMIZE UPLIFT TENDENCY.
2. KEEP POST OR ASSEMBLY OUT OF WET CONDITIONS.

CHANGE OF VERTICAL ALIGNMENT

DEPRESSION – AS SHOWN

SUMMIT – SIMILAR EXCEPT NO HOLD-DOWN ANCHORS REQUIRED.

NOT TO SCALE

ALL DIMENSIONS ARE IN MILLIMETRES UNLESS OTHERWISE NOTED

TYPE A, B, B1, C, C1 & C2 FENCE SPECIAL CONDITIONS

SP741-04.03

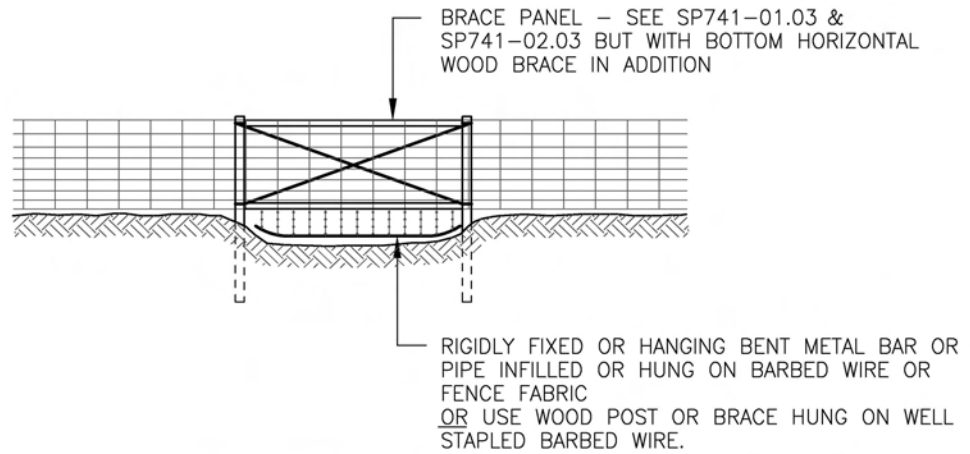

CONTINUOUS FENCING
(AT DITCHES, ETC.)

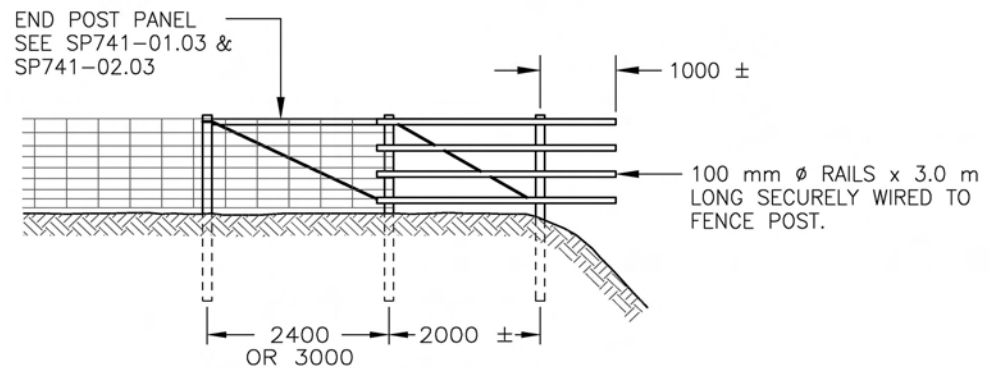

INTERRUPTED FENCES
(AT GULLEY OR CREEK)

NOT TO SCALE

ALL DIMENSIONS ARE IN MILLIMETRES UNLESS OTHERWISE NOTED

FARM AND RANGE GATES

SP741-04.04

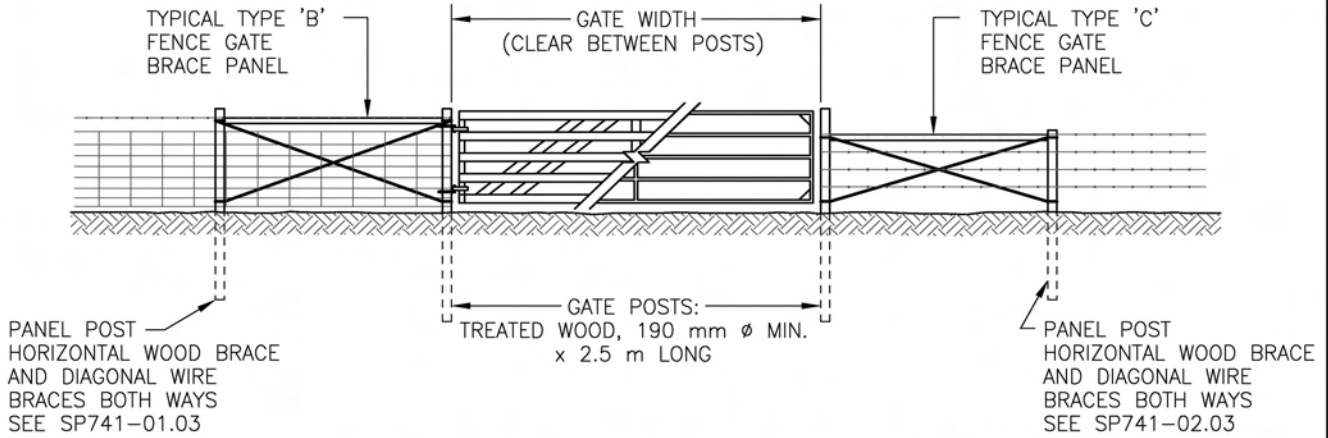

GATES IN TYPE A, B, B1, C, C1 & C2 FENCES

(SEE SP741-05.03 FOR TYPE D FENCE GATE)

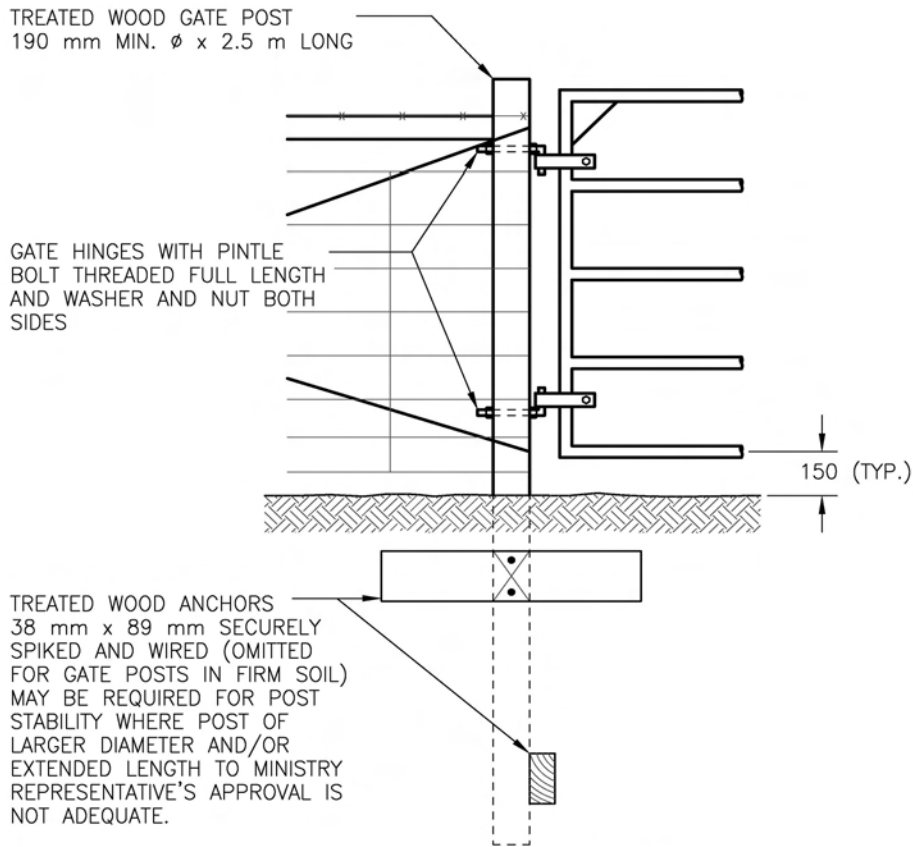

TYPICAL HINGE DETAILS

NOTE: SEE SP741-04.05 FOR GATE TYPES AND APPLICATIONS

NOT TO SCALE

ALL DIMENSIONS ARE IN MILLIMETRES UNLESS OTHERWISE NOTED

FARM AND RANGE GATES

SP741-04.05

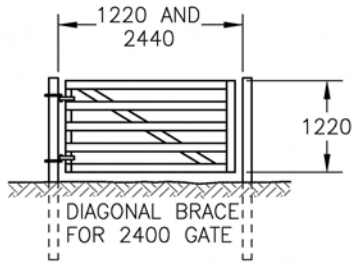

TYPE 1 GATE
(SHEET METAL MEMBERS)

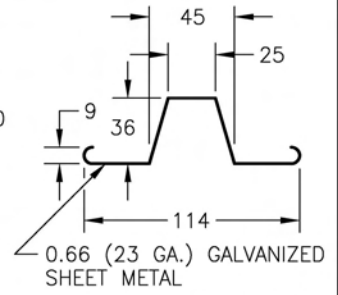
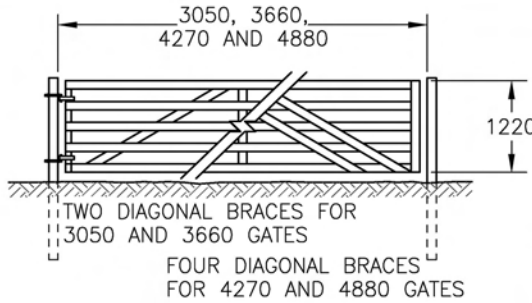

GATE MEMBER

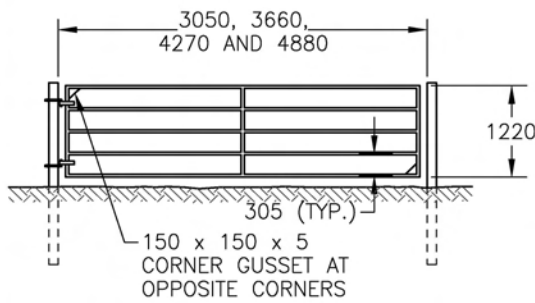

TYPE 2 GATE
(ALL PIPE)

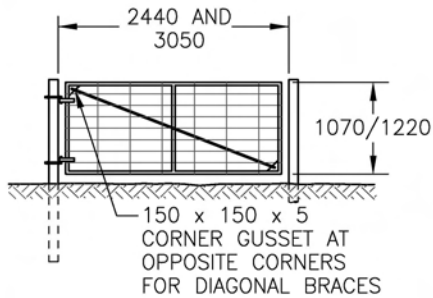

TYPE 3 GATE
(PIPE AND WIRE FABRIC INFILL)

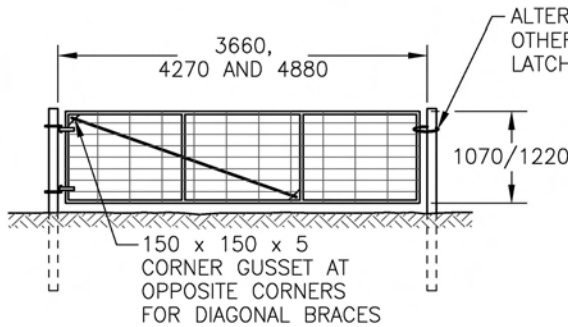

NOTE:
GATE CONSTRUCTION AND
HARDWARE SPECIFICATION
SEE SUBSECTION 316.11

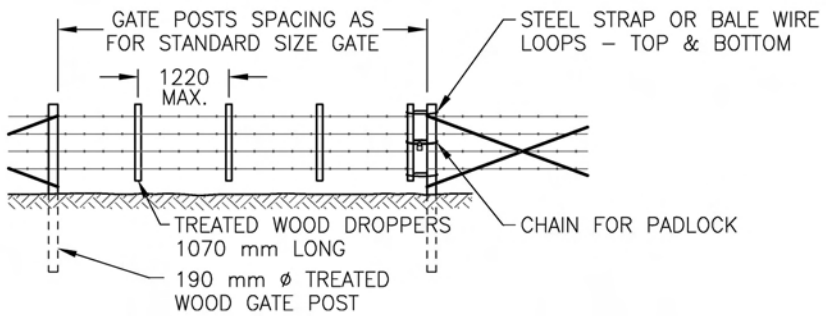

TYPE 5 GATE
(RANGE SLIP-WIRE)

NOTE:
SEE SP741-04.04 FOR GATE DETAILS

NOT TO SCALE

ALL DIMENSIONS ARE IN MILLIMETRES UNLESS OTHERWISE NOTED

TYPE D – CHAIN LINK FENCE – GENERAL LAYOUT

SP741-05.01

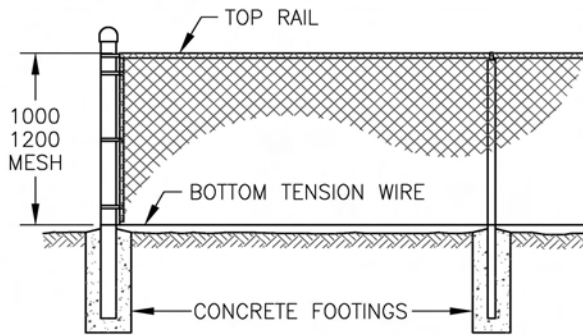

RESIDENTIAL HEIGHT
(1.0 OR 1.2 m)

CONCRETE FOOTINGS

MIX: AGGREGATE, SAND AND PORTLAND CEMENT (4 : 2 : 1)
MINIMUM STRENGTH 18 MPa

MESH HEIGHT "X" (mm)	CONCRETE FOOTINGS SIZE * (mm)					
	TERMINAL POSTS			LINE POSTS		
	a	b	c	d	e	f
1000	200	750	600	200	600	450
1200	200	750	600	200	600	450
1500	300	1050	900	250	750	600
1800	300	1050	900	250	750	600
2100	350	1050	900	300	900	750
2400	350	1050	900	300	900	750

* INCREASE FOR PEAT SOIL ETC.
FOR ROCK AND OTHER CONDITIONS SEE SUBSECTION 741.36.01(iii)

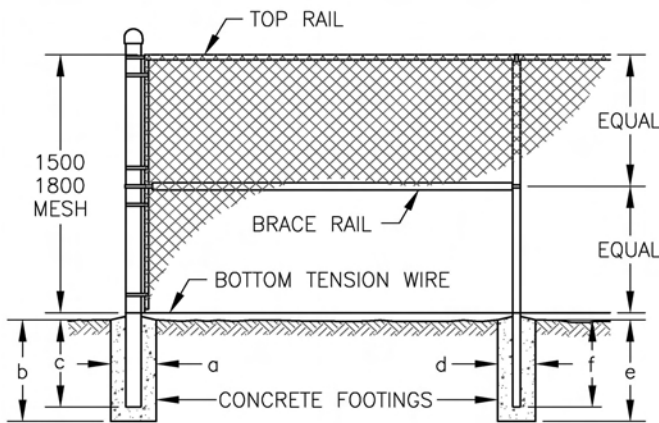

STANDARD HEIGHT
(1.5 OR 1.8 m)

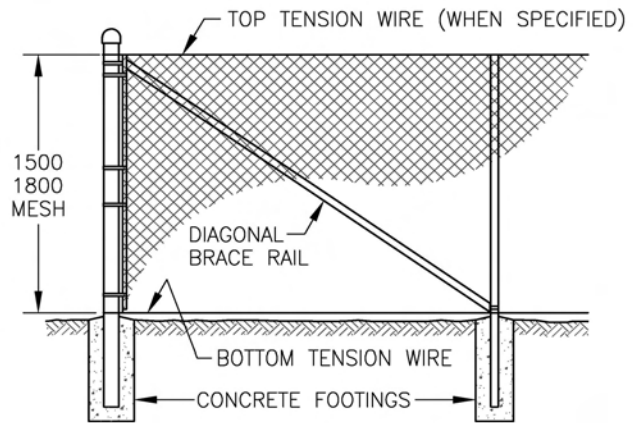

NOTE:
INTERMEDIATE TENSION ASSEMBLIES WITH TOP TENSION WIRE REQUIRE DIAGONAL BRACE ON EACH SIDE.

EXTENDED POST, STRAINING AND INTERSECTION POST SIMILAR

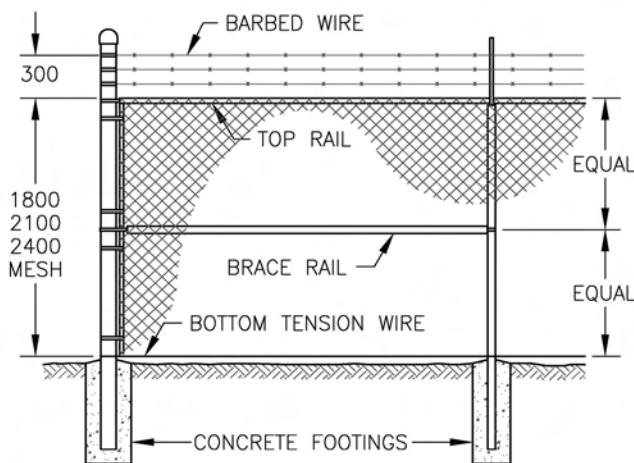

SECURITY HEIGHT
(1.8, 2.1 OR 2.4 m EXCLUSIVE OF BARBED WIRE HEIGHT)

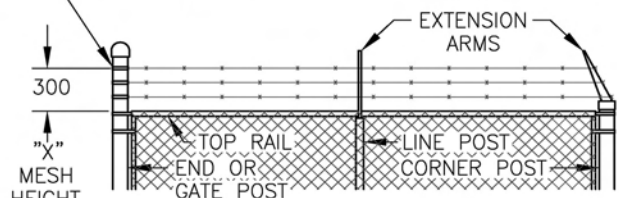

SECURITY FENCE

(EXTENSION ARMS AND EXTRA HEIGHT END, GATE AND STRAINING POSTS FOR 3 STRANDS OF BARBED WIRE)

GENERAL NOTES:

- MATERIAL SPECIFICATIONS FOR PIPE, MESH AND BARBED WIRE SEE SECTION 316.
- MESH FABRIC SELVAGE EDGE:
 - TWISTED EDGE UP FOR 1.8 m OR GREATER HEIGHT EXCEPT
 - KNUCKLE EDGE UP FOR 1.8 m HEIGHTS FOR SCHOOL, PARK OR PLAYGROUNDS
 - KNUCKLE SELVAGE BOTH EDGES FOR 1.5 m AND LESS.
- ACCESSORY MATERIAL SEE SP741-05.02
- INSTALLATION, INCLUDING STRAINING POST REQUIREMENTS SEE SUBSECTION 741.36.
- GATE DETAILS SEE SP741-05.03 & SP741-05.04.

NOT TO SCALE

ALL DIMENSIONS ARE IN MILLIMETRES UNLESS OTHERWISE NOTED

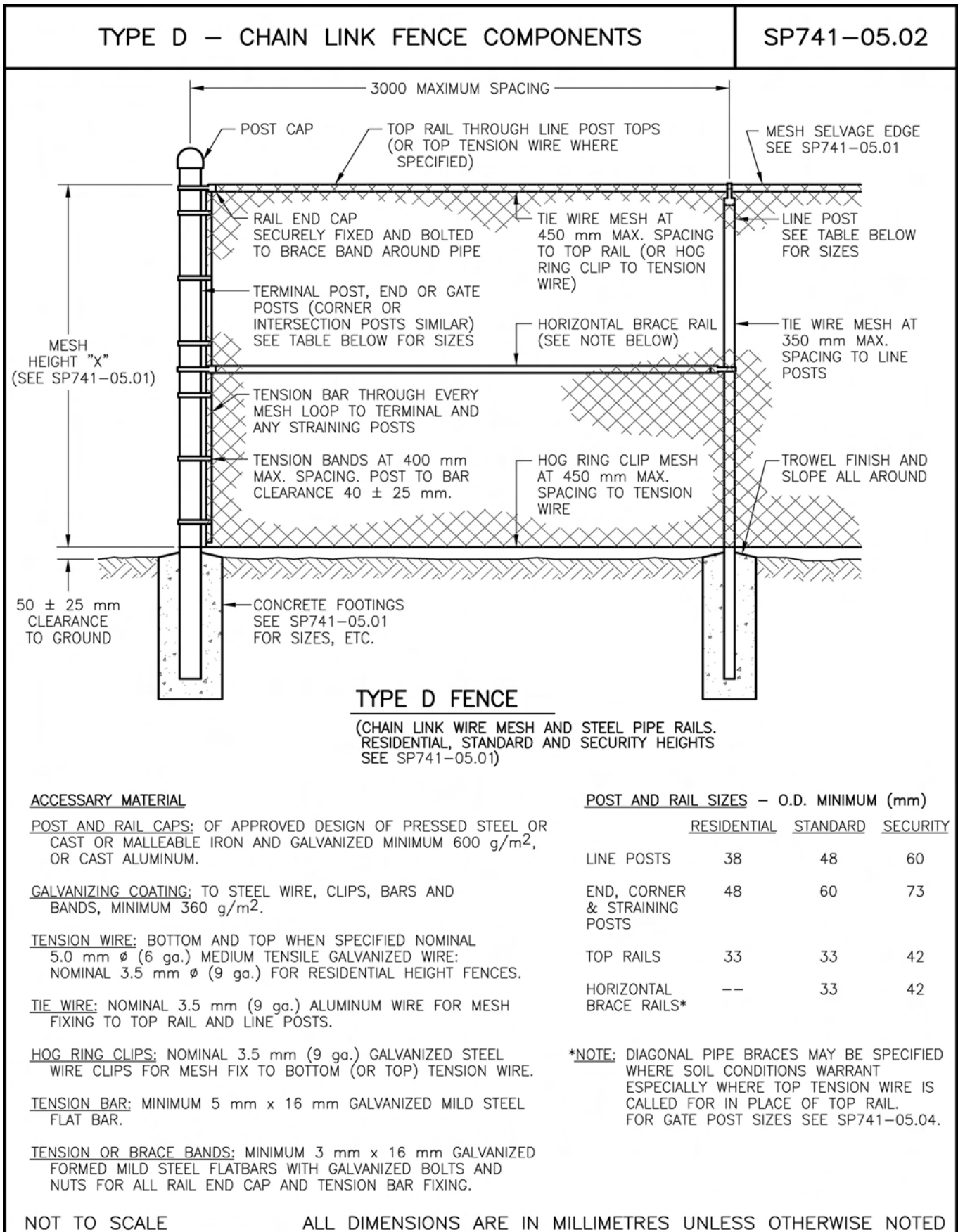

TYPE D – CHAIN LINK FENCE GATES

SP741-05.03

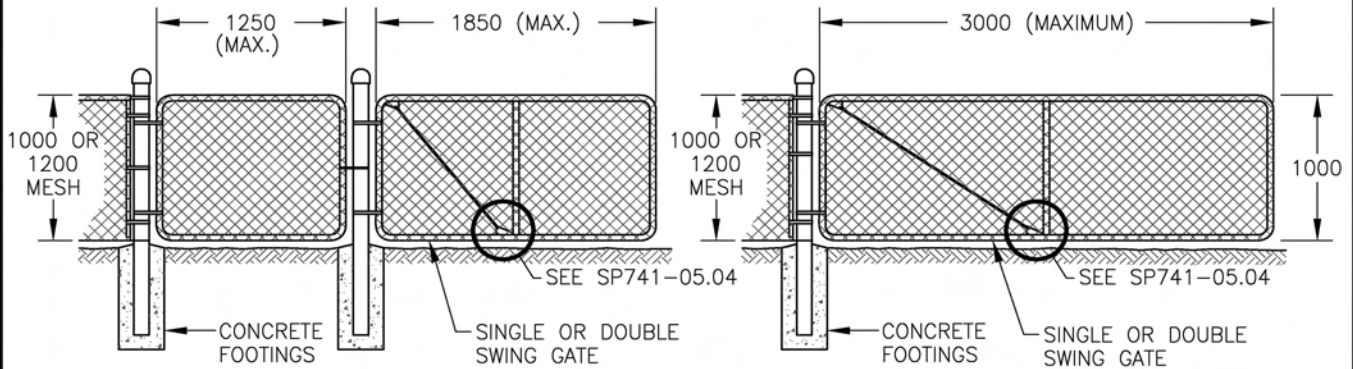

- GATES NOT EXCEEDING 1.85 m WIDTH OF OPENING
- GATE FRAME: 33 mm O.D. GALVANIZED TUBING 1.9 kg/m
 - VERTICAL PIPE BRACE: 27 mm O.D. GALVANIZED TUBING 1.5 kg/m
 - DIAGONAL BRACE: 5.0 mm NOMINAL DIAMETER GALVANIZED TENSION WIRE TO 5 mm CLEATS AS ON SP741-05.04.

- GATES NOT EXCEEDING 3.0 m WIDTH OF OPENING
- GATE FRAME: 33 mm O.D. GALVANIZED TUBING 2.5 kg/m
 - VERTICAL BRACE: 27 mm O.D. GALVANIZED PIPE 1.7 kg/m
 - DIAGONAL BRACE: 9.5 mm NOMINAL DIAMETER GALVANIZED ROD WITH HOOKED ENDS TO 5 mm CLEATS AS ON SP741-05.04

RESIDENTIAL HEIGHT GATES

(TYPE IV – SEE SUBSECTION 316.11.05)

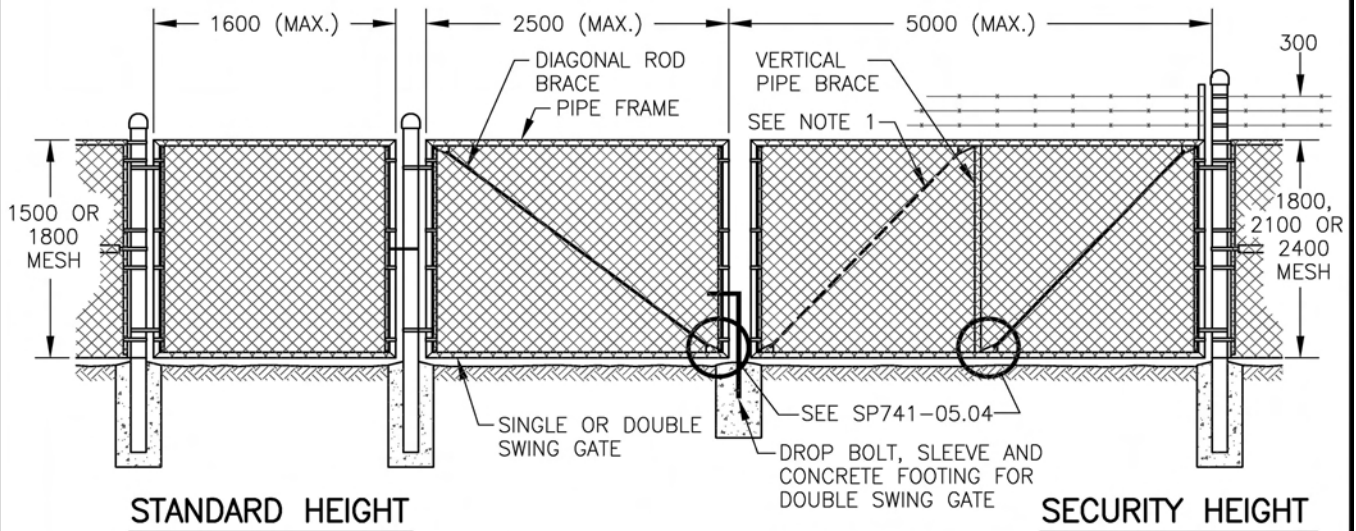

- GATE FRAME: 42 mm OD GALVANIZED PIPE 3.4 kg/m.
- VERTICAL PIPE BRACE: 33 mm OD GALVANIZED PIPE 2.5 kg/m
- DIAGONAL BRACE: 9.5 mm DIAMETER GALVANIZED ROD TO 5 mm CLEATS AS SHOWN ON SP741-05.04.

NOTE 1: SECOND DIAGONAL ROD BRACE REQUIRED FOR ALL GATES OVER 3.0 m TO 5.0 m WIDTH OF OPENINGS: REVERSE SLOPE OF SECOND ROD FOR ALL SLIDING GATES.

STANDARD AND SECURITY HEIGHT GATES

(TYPE IV – SEE SUBSECTION 316.11.05)

NOTE:
FOR FENCE GATE DETAILS SEE SP741-05.04.

NOT TO SCALE

ALL DIMENSIONS ARE IN MILLIMETRES UNLESS OTHERWISE NOTED

TYPE D – CHAIN LINK FENCE GATE DETAILS

SP741-05.04

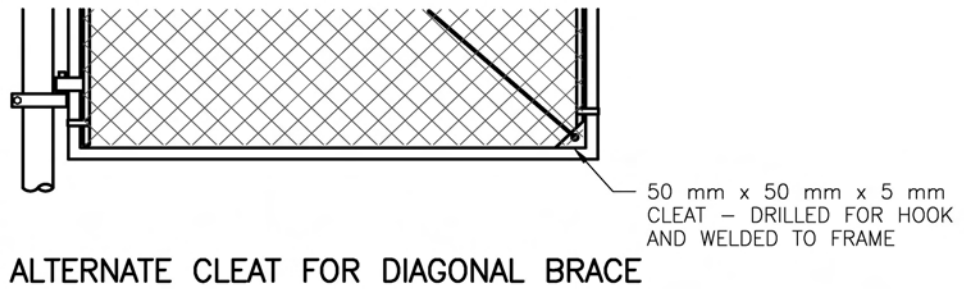
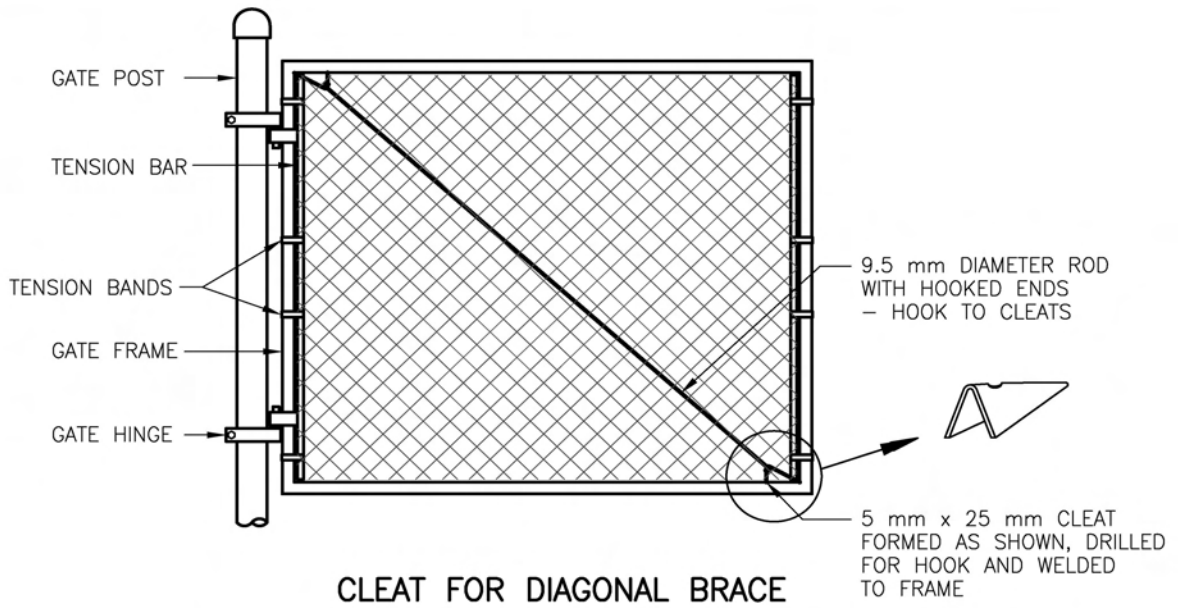

GATE POST SIZES – NOMINAL OUTSIDE DIAMETER

RESIDENTIAL		48 mm
STANDARD HEIGHT FENCE GATE	NOT EXCEEDING 2.5 m	60 mm
	EXCEEDING 2.5 m	73 mm
SECURITY HEIGHT FENCE GATE	NOT EXCEEDING 2.5 m	73 mm
	EXCEEDING 2.5 m	89 mm

CONCRETE FOOTING SIZES – UP TO 2.5 m WIDE GATES SEE SP741-05.01.
 – OVER 2.5 m WIDTH, FOOTINGS 400 mm ϕ , 1250 mm DEEP

SECURITY HEIGHT FENCE GATES TYPE 4

SIMILAR TO STANDARD HEIGHT BUT WITH EXTENDED VERTICAL STILES (AND BRACE) FOR BARBED WIRE OVER.

GENERAL NOTES

- MATERIAL SPECIFICATIONS FOR PIPE, MESH AND BARBED WIRE, SEE SECTION 316.
- CAPS AND ACCESSORY MATERIAL, SEE SP741-05.02.
- HARDWARE, SEE SUBSECTION 316.11.05.
- SLIDING GATE MAY BE DETAILED FOR GATE OPENINGS OVER 4.0 m WITH ROLLING HARDWARE AS REFERRED TO IN SUBSECTION 316.11.05.

NOT TO SCALE

ALL DIMENSIONS ARE IN MILLIMETRES UNLESS OTHERWISE NOTED

WOOD FENCE – PRIVACY – GENERAL ARRANGEMENT

SP741-06.01

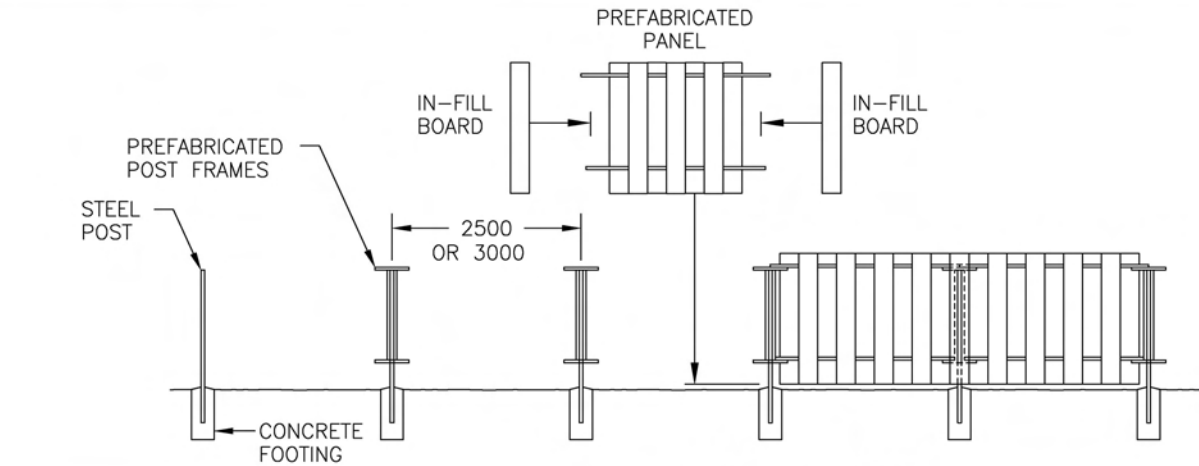

GENERAL ARRANGEMENT
ELEVATION

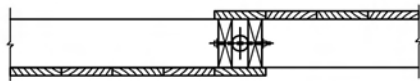

CLOSE BOARDING
(IN ALTERNATE PANELS)

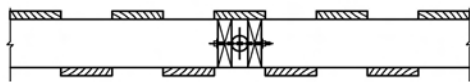

STAGGERED BOARDING

BOARDING ARRANGEMENT

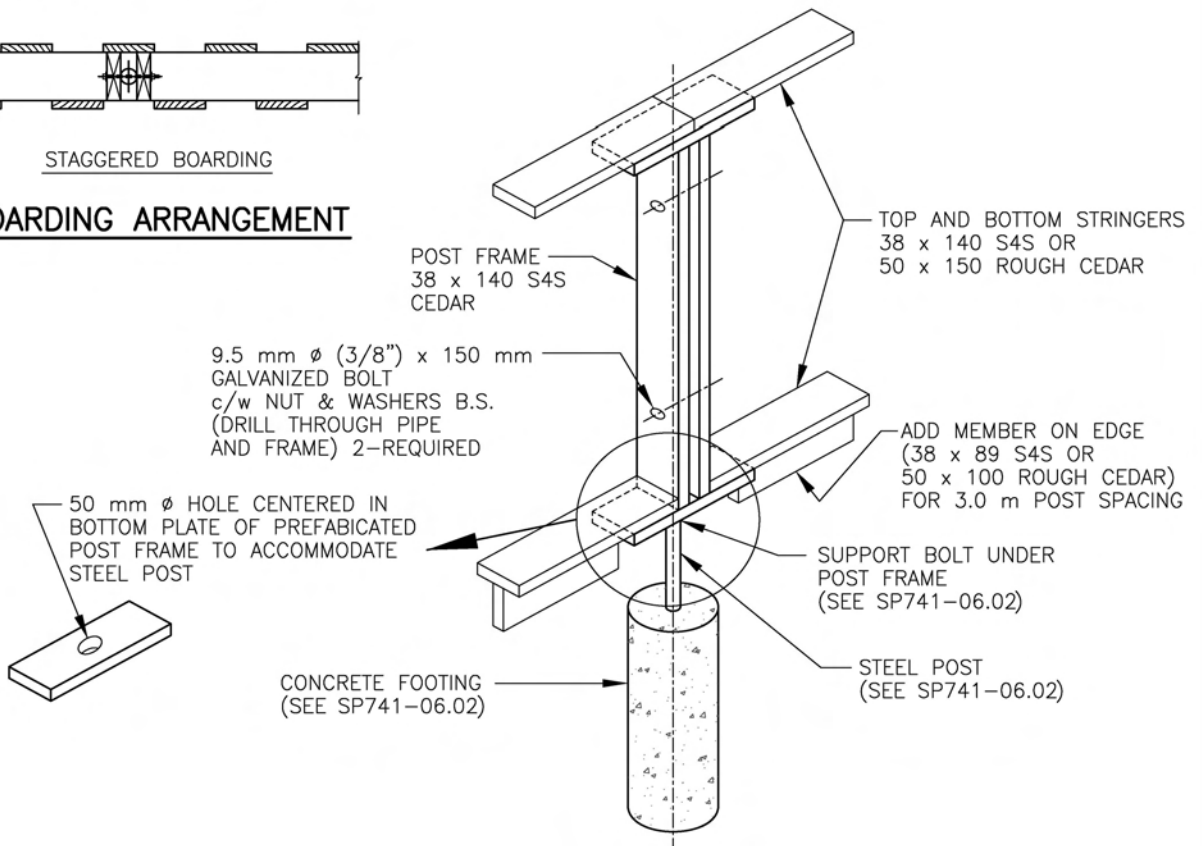

ISOMETRIC DETAIL

NOT TO SCALE

ALL DIMENSIONS ARE IN MILLIMETRES UNLESS OTHERWISE NOTED

WOOD FENCE – PRIVACY – DETAILS

SP741–06.02

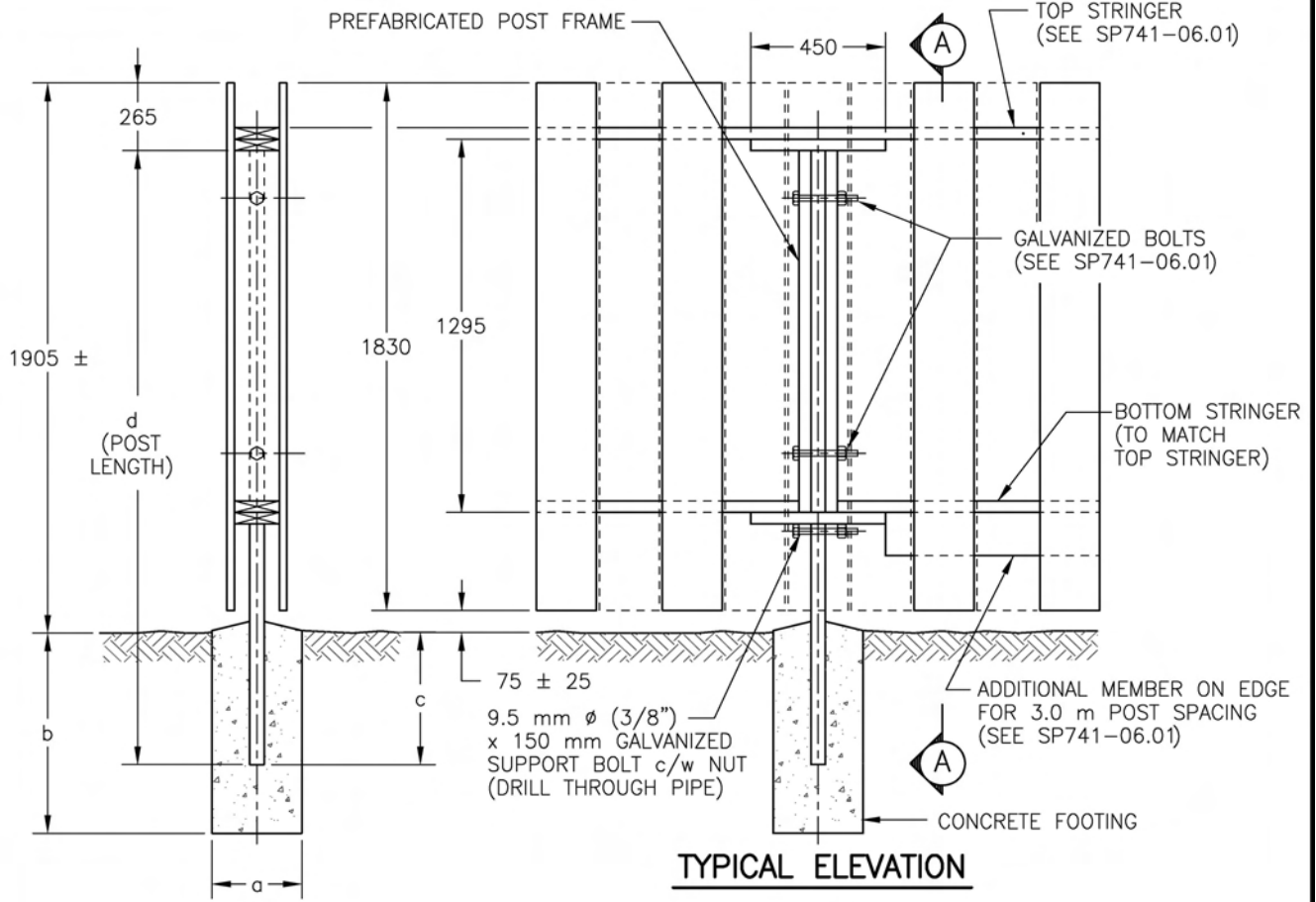

SECTION A

TYPICAL ELEVATION

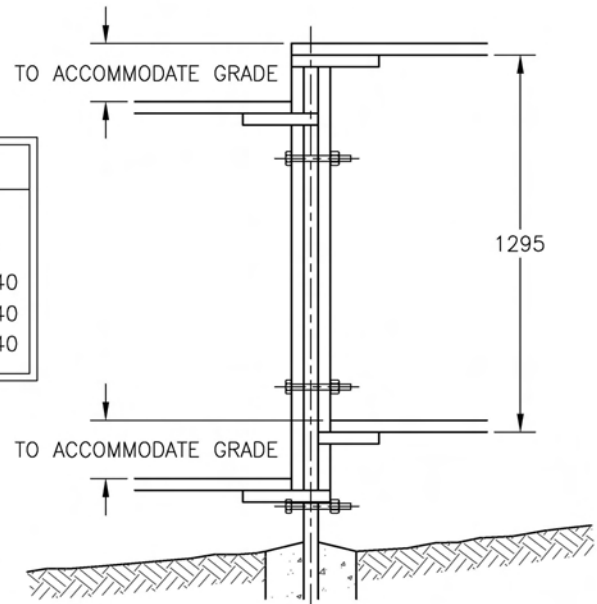

DETAIL – STEPPED POST FRAME

CONCRETE FOOTING AND POST

POST SPACING	2.5 m				3.0 m			
	a	b	c	d	a	b	c	d
FIRM SOIL	200	750	500	2140	250	750	500	2140
STANDARD	250	750	500	2140	300	750	500	2140
PEAT SOIL	300	750	500	2140	300	1000	800	2440

CONCRETE FOOTINGS:

MIX: AGGREGATE, SAND AND PORTLAND CEMENT (4:2:1)
 MINIMUM COMPRESSIVE STRENGTH 18 MPa.

STEEL POSTS:

POSTS TO BE 48 mm O.D. GALVANIZED STANDARD WEIGHT TUBING.

NOT TO SCALE

ALL DIMENSIONS ARE IN MILLIMETRES UNLESS OTHERWISE NOTED

WOOD FENCE – PRIVACY – GENERAL ARRANGEMENT

SP741-06.03

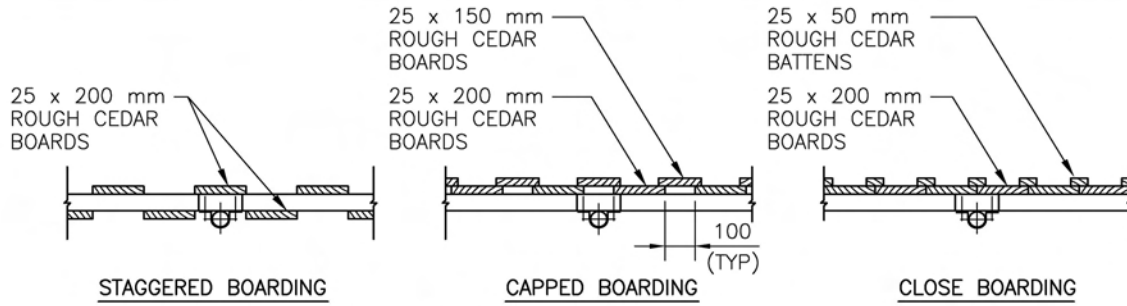

BOARDING ARRANGEMENT

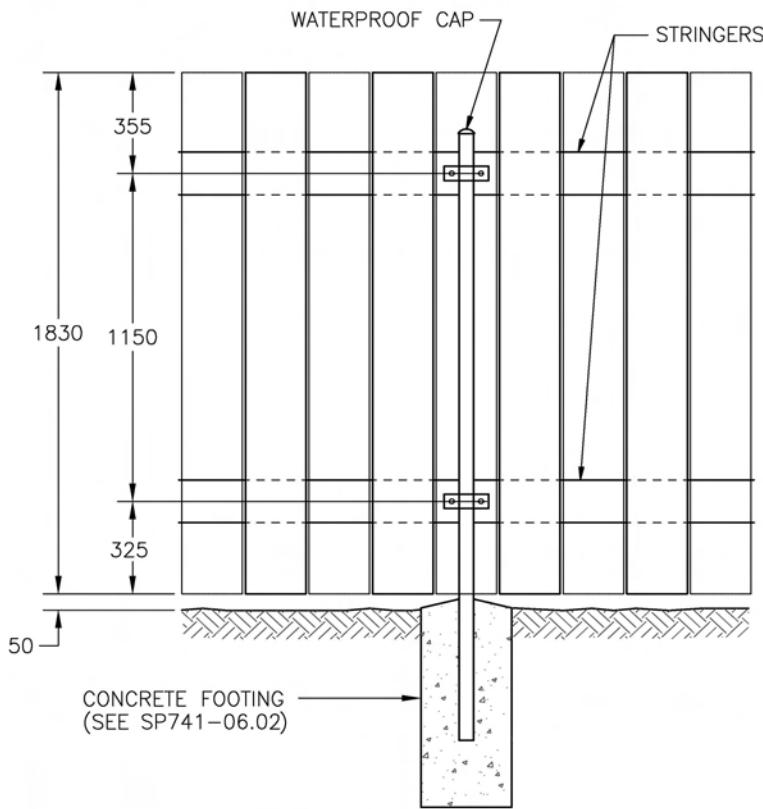

TYPICAL ELEVATION

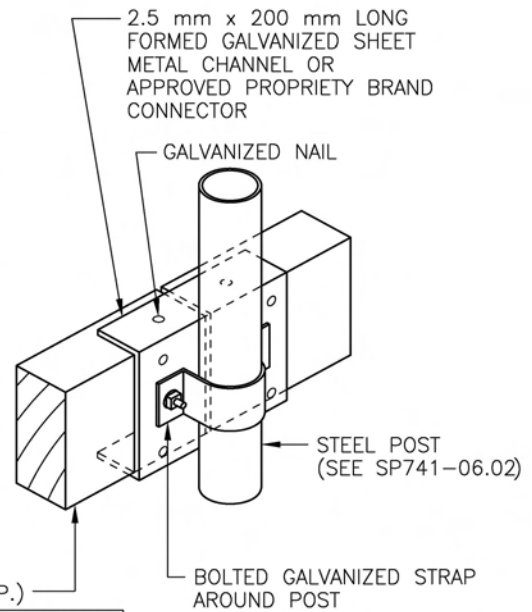

STRINGERS: (TYP.)

50 x 100 ROUGH CEDAR FOR 2.5 m POST SPACING

50 x 150 ROUGH CEDAR FOR 3.0 m POST SPACING

ISOMETRIC DETAIL

NOT TO SCALE

ALL DIMENSIONS ARE IN MILLIMETRES UNLESS OTHERWISE NOTED

SIDEWALK FENCE – WELDED OR SLIP-ON

SP741-07.01

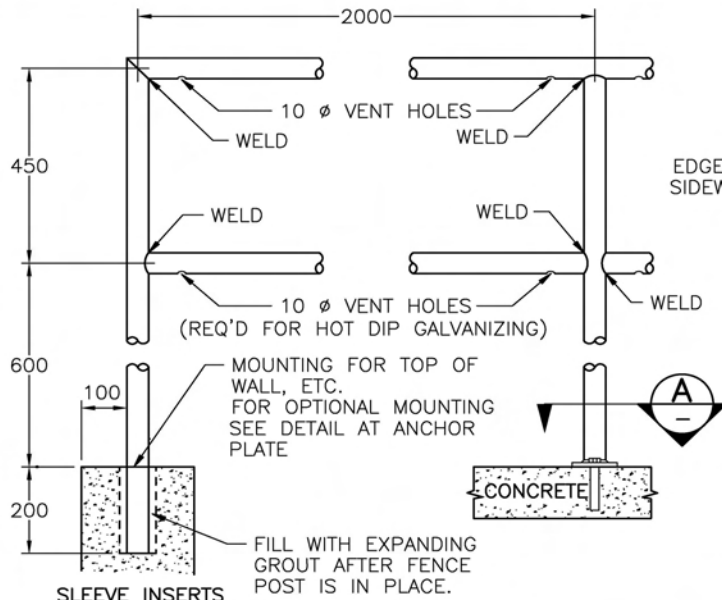

WELDED FENCE

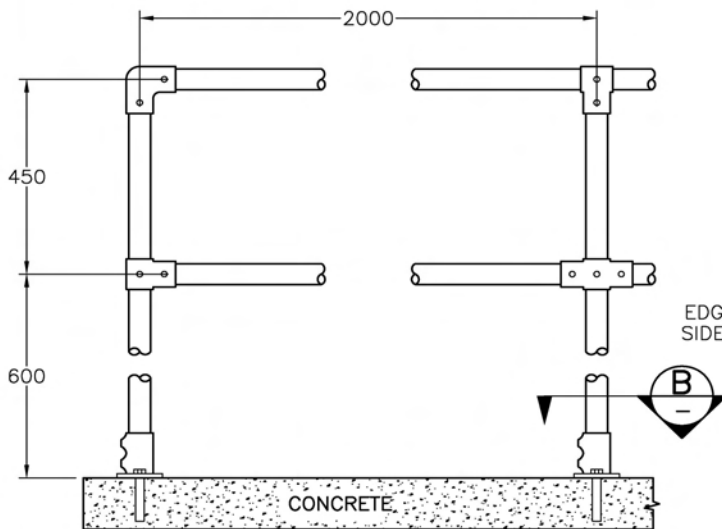

SLIP-ON FENCE

NOTES:

1. ALL POSTS AND RAILS TO BE 48 mm O.D. TO ASTM A 53 'STANDARD' WEIGHT (SCHEDULE 40) GALVANIZED PIPE.
2. WELDS SHALL BE FULL BEAD.
3. FIELD WELDS SHALL HAVE ROUGH EDGES GRIND SMOOTH IMMEDIATELY FOLLOWED BY TWO APPLICATIONS OF A ZINC RICH COATING CONFORMING TO CGSB 1-GP-181 M.
4. PIPE FITTINGS SHALL BE GALVANIZED MALLEABLE IRON WITH CASE HARDENED SET SCREWS CONFORMING TO ASTM A 47 GRADE 32510 AND ASTM A 153.
5. WELDED FENCE TO BE GALVANIZED AFTER FABRICATION.
6. GALVANIZING SHALL BE IN ACCORDANCE WITH CSA SPECIFICATION G164 TABLE 1.

NOT TO SCALE

ALL DIMENSIONS ARE IN MILLIMETRES UNLESS OTHERWISE NOTED

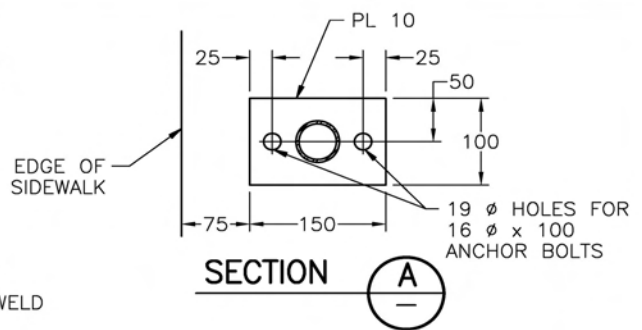

SECTION A

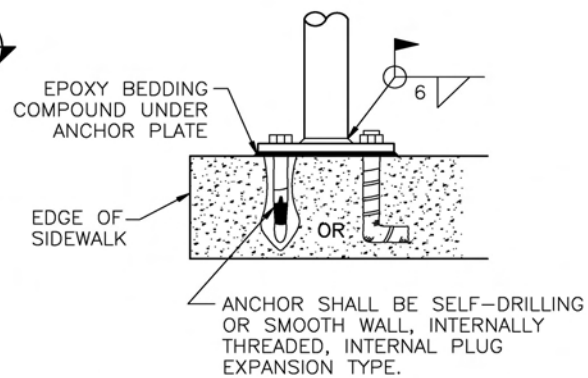

DETAIL AT ANCHOR PLATE

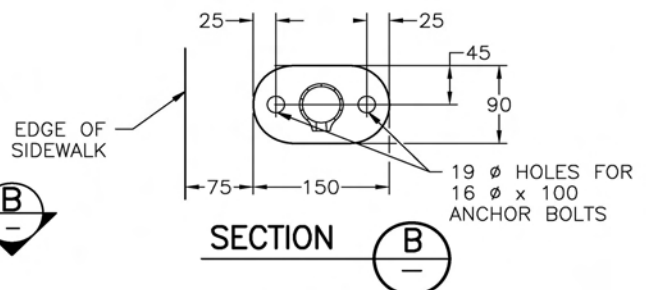

SECTION B

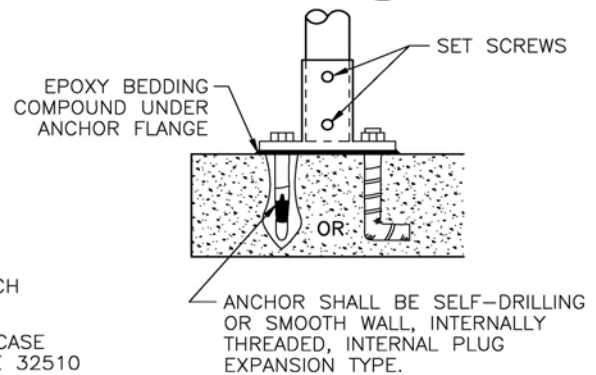

DETAIL AT ANCHOR FLANGE

BICYCLIST SIDEWALK FENCE – WELDED OR SLIP-ON
 SUITABLE FOR LOCATIONS WHERE GATHERING OF MANY PEOPLE IMPROBABLE

SP741-07.02

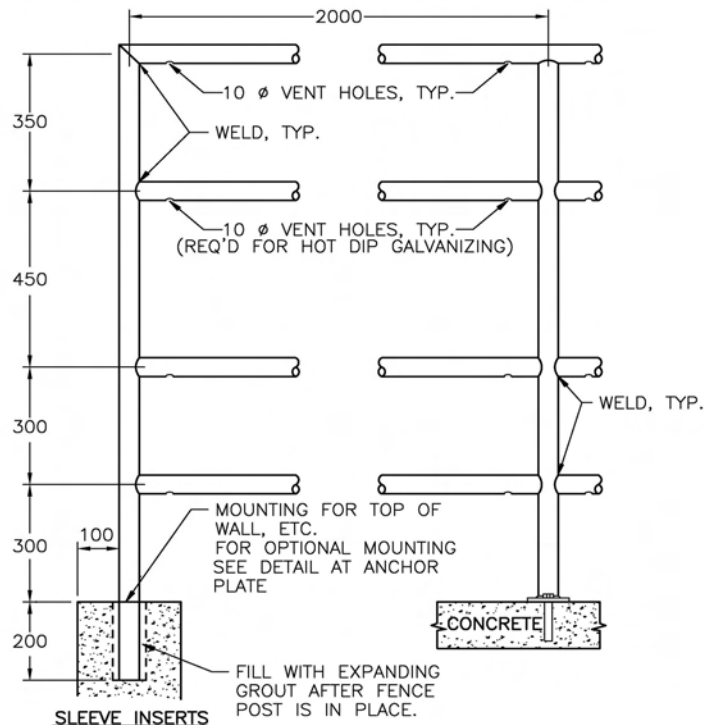

WELDED FENCE

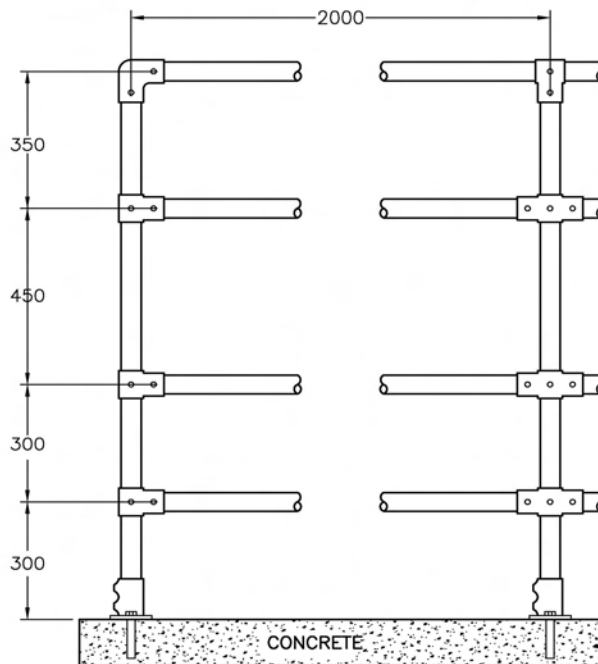

SLIP-ON FENCE

NOTES:

1. ALL DETAILS NOT SHOWN SIMILAR TO SP741-07.01.
2. BASE PLATES TO BE 12.7 mm THICK.
3. ALL POSTS TO BE 48 mm O.D. TO ASTM A53 GRADE 240 MPa 'XXS' (SCHEDULE 160).

NOT TO SCALE

ALL DIMENSIONS ARE IN MILLIMETRES UNLESS OTHERWISE NOTED

FENCE – WELDED OR SLIP-ON RAIL SPLICE

SP741-07.03

MECHANICALLY REDUCED
PIPE SECTION, OUTSIDE DIA.
REDUCED TO BE ABLE TO
SLIDE INTO NORMAL PIPE
SECTION WITH 2 mm CLR.

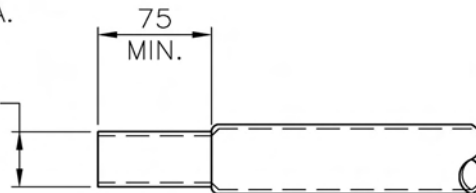

SWAGE PIPE END

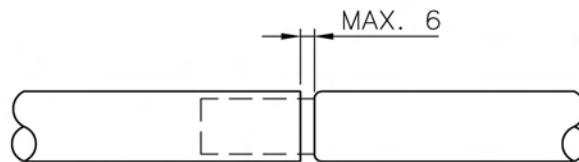

INSTALLATION OF SWAGE PIPE END

NOTE: SPLICES TO BE SPACED A MINIMUM OF 7 m APART

NOT TO SCALE

ALL DIMENSIONS ARE IN MILLIMETRES UNLESS OTHERWISE NOTED

THIS PAGE IS LEFT INTENTIONALLY BLANK

SECTION 751

TOPSOIL AND LANDSCAPE GRADING

DESCRIPTION

751.01 Scope – This Section refers to those portions of work that are unique to the supply and placement of topsoil and subsequent finish grading. In this Section, the term "topsoil" is used to identify either:

- a) On-Site topsoil: material stockpiled for use, or
- b) Imported topsoil, or
- c) Manufactured topsoil (Growing Medium).

751.02 Related Work – SS 754, Planting of Trees, Shrubs and Ground Covers; SS 757, Revegetation Seeding.

751.03 References – Canadian System of Soil Classification, Canada Fertilizer Act, Canadian National Master Specification.

751.04 Topsoil Supplied by the Contractor – The Contractor shall advise the Ministry Representative of the sources of topsoil not less than seven days before any is used in the work.

The Contractor shall, at the Contractor's expense, acquire a soil analysis from an accredited soil testing laboratory, to verify that supplied material is within the requirements indicated. Results of the soil test are to be submitted to the Ministry Representative prior to installation.

The Ministry Representative will approve all topsoil once it has met the standard required at the source.

MATERIALS

751.11 General – In this Section, a range of measurable physical and chemical properties are set out as being acceptable in a topsoil. Compliance with this Section shall be determined by testing for those properties. When imported or on-Site topsoil is used, it shall be tested and modified as necessary by a mixture of other components to bring its properties to within the range set in SS 751.16, or as stated in the Special Provisions. Topsoil shall not be prepared or handled in an excessively wet or frozen condition, or in any manner in which structure is adversely affected.

751.12 Topsoil Types – Three topsoil types are described in SS 751.13 through SS 751.15. Regardless of origin, all types shall conform to SS 751.16.

751.13 On-Site Topsoil – On-Site topsoil may be used, as specified in the Special Provisions, provided that it meets the standard set for imported topsoil and can be modified to meet the requirements set out for the specified topsoil. On-Site topsoil shall be defined as the existing "A" horizon containing accumulated organic matter. On-Site topsoil shall be tested prior to stockpiling. Upon approval

by the Ministry Representative of the suitability of the on-Site topsoil for topsoil, a sufficient quantity of stripped on-Site topsoil shall be stockpiled where shown on the Drawings or in areas designated for stockpiling.

751.14 Imported Topsoil – Imported topsoil shall be of a sandy loam or loamy sand texture (no less than 50% sand by weight) containing between 4% and 15% organic matter (dry weight basis).

Imported topsoil shall be free of propagules of plant species designated as noxious weeds under the BC Weed Control Act and Regulation and other perennial, weedy plants such as couch-grass, horsetail, broom, Japanese Knotweed and blackberry species.

At least 80% of imported topsoil shall pass a Tyler #10 sieve after appropriate crushing of structural units using accepted laboratory test methods.

751.15 Manufactured Topsoil – Manufactured topsoil is any soil or growing medium mixture whose chemical and physical properties fall within ranges required by this Section for a particular application.

Manufactured topsoil shall conform to SS 751.16 or as specified in the Special Provisions.

751.16 Requirements For Topsoil – Commercial processing and mixing of topsoil components shall be done thoroughly by a mechanized screening process. No hand mixing shall occur. The resulting product shall be a homogenous mixture having the required properties throughout.

The general amendment of both natural topsoils and manufactured topsoils by mixing in situ with rototill cultivation equipment after placement, will be acceptable if carried out to the satisfaction of the Ministry Representative. Fertilizers typically used at time of seeding or planting will be surface applied and incorporated as described in SS 751.33, Applying Fertilizers.

The Contractor shall also require the laboratory to include recommendations for incorporating fertilizers and other amendments into the topsoil as needed for plant establishment and maintenance, and as they specifically relate to:

- grassed areas
- ground covers, shrubs and trees
- container or planter box installations, and to site conditions and season of planting.

Refer to Table 751-A for required properties of growing medium for different applications.

TABLE 751-A PROPERTIES OF TOPSOIL FOR DIFFERENT APPLICATIONS

PROPERTIES	Low Traffic Lawn Areas Trees and Large Shrubs	Planting Areas, Planters, Shrub and Groundcover Areas
TEXTURE: Particle size classes by the Canadian system of soil Classification	Percent of Dry Weight Mineral Fraction (%)	
Gravel greater than 2 mm, less than 30 mm	0 – 10	0
Sand greater than 0.05 mm, less than 2 mm	50 – 70	50 – 70
Silt & Clay combined	Maximum 25%	Maximum 25%
ACIDITY (pH)	6.0 – 7.0	4.5 – 6.5
DRAINAGE: Minimum saturated hydraulic conductivity (cm/hr) in place	2.0	2.0
ORGANIC CONTENT: Percent of Dry Weight (%)	5 – 10	14 – 20

Other specific requirements are as follows:

Fertility :

- Nitrogen – total nitrogen shall be 0.2% to 0.6% by weight.
- Phosphorus – available phosphorus shall be 20 to 100 ppm.
- Potassium – available potassium shall be 50 to 250 ppm.
- Boron – concentration in saturation extract shall not exceed 1 ppm

General:

- Acidity – in accordance with Table 751-A. Maximum of 0.5 kg/m² of dolomite lime to achieve the required pH level.

- Salinity – saturation extract conductivity shall not exceed 3.0 mmho/cm at 25°C. Sodium absorption ration (SAR) as calculated from analysis of saturated extract shall not exceed 8.0.

- C/N ratio – carbon to nitrogen ration shall not exceed 40:1.
- Texture – in accordance with Table 751-A.
- Organic content – in accordance with Table 751-A
- Cedar or redwood sawdust shall not be present in the topsoil.
- Soil shall be virtually free from subsoil, wood including woody plant parts, weeds, toxic materials, stones over 30 mm, and foreign objects.
- Drainage – in accordance with Table 751-A. Drainage of growing medium can be measured only after growing medium is in place. Mixing and handling of growing medium shall be done in such a manner that the minimum saturated hydraulic conductivity indicated is achieved.

751.17 Soil Amendments – The following amendments shall be added to the topsoil as required.

751.17.01 Peat Moss – Peat moss shall be Horticultural grade, partially decomposed fibrous or cellular stems and leaves of sphagnum mosses with a texture varying from porous to spongy fibrous, fairly elastic and substantially homogeneous with pH value not less than 3.5 and not greater than 6.5, medium to coarse shredded, suitable for horticultural purposes.

751.17.02 Sand – Sand shall be clean river pump sand or alternative source approved by the Ministry Representative, free of impurities, chemical or organic matter.

Particle size in sand shall be as follows:

- 95 – 100% passing a 4.75 mm sieve;
- 0 – 40% passing a 0.600 mm sieve;
- 0 – 5% passing a 0.075 mm sieve.

751.17.03 Manure and Compost – Manure shall be well-rotted farm animal manure or mushroom manure, rotted to the extent that the material is crumbly. Manure shall be free from weed seeds, rocks, sticks, rubble and shall contain not more than 40% composted sawdust, straw or shavings. Manure shall be free of propagules of plant species designated as noxious weeds under the BC Weed Control Act & Regulation and other perennial, weedy plants such as couch-grass and horsetail.

Commercial compost shall be free from all weed seeds, coliform, pathogens and chemical or toxic contaminants. Physical contaminants such as rocks, plastic, metal or glass shall be less than 0.5%. Compost shall not be derived from or contain processed municipal sewage sludge, unless such product is authorized for use by the

SECTION 751

Ministry of Water, Land and Air Protection, and meets all local regulations and approvals.

751.17.04 Wood Residuals – Raw sawdust and woodwaste are not acceptable components of topsoil. Wood residuals used as a component of topsoil, compost, farm animal manure or mushroom manure are acceptable provided they are rotted and the total Carbon to total Nitrogen ratio for the topsoil is a maximum of 40:1.

751.18 Fertilizers – Fertilizers shall be standard commercial brands, meeting the requirements of the Canada Fertilizer Act.

All fertilizers shall be in granular, pelleted or prill form, and shall be dry, free-flowing and free from lumps.

Fertilizers shall be packed in standard waterproof containers, clearly marked with the name of the manufacturer, weight and guaranteed analysis.

All fertilizer shall be stored in a weatherproof storage place and in such a manner that it will stay dry and its effectiveness will not be impaired.

The types, formulations, and rates of application for fertilizers and liming agents to topsoil supplied by the Contractor shall be as recommended by a laboratory soil specialist on the basis of tests of the topsoil, and as approved by the Ministry Representative.

Substitutions or variations in fertilizers and methods shall be made only upon pre-approval by the Ministry Representative.

751.19 Fill Material – Fill Material shall not be toxic to plant and animal life in part or in concentration.

CONSTRUCTION

751.31 Area Preparation

751.31.01 Stripping of Topsoil – Existing top soil material, where specified or required by the Ministry Representative shall be stripped and removed to stockpile(s) within the project area, kept properly drained, and maintained in a neat and presentable condition free of spoil and subsoil material for subsequent spreading on prepared rough graded areas.

The storage of topsoil shall not interfere with the effective utilization of a granular source or borrow pits.

751.31.02 Preparation of Landscape Area Subgrade – This Section applies only to grading of landscaped areas outside the roadway prism.

Rough grading shall be carried out by necessary cutting and filling work to produce the lines and grades shown on the Drawings and as directed by the Ministry Representative, allowing for the stipulated new topsoil thickness.

Surplus excavated material shall be removed from the Site and disposed of at the Contractor's expense unless the

TOPSOIL AND LANDSCAPE GRADING

Ministry Representative authorizes its use as fill elsewhere on the project.

The landscape area subgrade shall be prepared to a consistent 80 – 85% Proctor density.

Soft and unstable areas below the landscape area subgrade that cannot be compacted to this standard shall be excavated and filled with suitable fill material, except in locations where special environmental conditions have been identified. In such cases, appropriate alternative solutions shall be approved by the Ministry Representative and environmental agencies as required, and carried out.

Debris, roots, branches, stones, building material, contaminated subsoil, visible weeds and anything else that may interfere with the proper growth and development of the planned finished landscaping shall be removed.

Fill materials shall be placed so as to achieve stability. This may necessitate placing in lifts of 225 mm and compacting each layer to 80 – 85% standard proctor density.

Grade transitions of landscape area subgrade should be smooth and even and shall be such that ponding cannot occur on the landscape area subgrade surface.

Existing land forms shall be warped and blended into the landscaped areas with a minimum of visual disharmony.

751.31.03 Fine Grading – Areas requiring topsoil shall be fine graded by raking out spoil material and debris such as rocks, asphalt and concrete over 50 mm in diameter.

Naturalized areas not requiring topsoil shall be similarly cleaned, raked and manicured.

751.31.04 Scarifying – All landscape area subgrade shall be scarified to a minimum depth of 150 mm immediately before placing topsoil.

751.31.05 Cleanup – All unsuitable material and inorganic debris shall be removed from the project area by the Contractor unless the Ministry Representative authorizes its use in fill areas on the project.

All surplus or unsuitable organic waste and debris shall be removed from the Site unless its complete burning is approved by the Ministry Representative in compliance with the B.C. open burning regulation.

751.32 Placing Topsoil – The landscape area subgrade shall be inspected and approved by the Ministry Representative, before topsoil is placed.

The topsoil shall be:

- placed over the prepared landscape area subgrade and shall be allowed to settle or be compacted by light rolling such that it is firm against deep footprints and shall not be compacted more than necessary to meet this requirement;
- moist (25% to 75% of field capacity) but not wet when placed, and shall not be handled if frozen or wet such that

SECTION 751

its structure will be altered;

- manually spread around trees, shrubs and obstacles;
- evenly spread to a depth which after settlement or light compaction will be that shown in the Drawings or as directed by the Ministry Representative.

During hauling and spreading, the paved roadway and other finished surfaces including subgrade under future base courses shall be kept clean and free of all topsoil.

751.33 Applying Fertilizers – Fertilizers shall be added to bring topsoil fertility within the ranges set out in this Section or as specified in the Special Provisions.

Manufactured topsoils and processed imported topsoils will typically have fertilizers and amendments incorporated at the time of mixing and screening, while other topsoils will receive in situ amendment.

Fertilizers normally applied at the time of seeding and planting are specified under the appropriate sections. These fertilizers are generally supplemental to the base fertility requirements outlined for topsoil and are applied after topsoil is in place.

Surface applied fertilizers shall be evenly spread over the topsoil with a suitable mechanical spreader and fully incorporated to a minimum depth of 50 mm.

Lime used for top dressing shall be thoroughly cultivated into the top 100 mm of topsoil.

751.34 Finish Grading – After placing the topsoil to the finish elevations and contours required, the grade shall be finished to a high standard, to the grades shown on the Drawings with a smooth and even surface. Rough spots and low areas shall be eliminated to ensure positive surface drainage, and the surface shall be left smooth, uniform, free of debris and firm enough to resist deep footprinting.

Topsoil placed in traffic islands and medians shall be crowned for drainage, as shown on Drawing SP751-01.

TOPSOIL AND LANDSCAPE GRADING

MEASUREMENT

751.81 General – Measurement for the supply of topsoil by the Contractor will be by the CUBIC METRE in the truck at the point of delivery. Topsoil removed from stockpiles will be measured in place in the stockpile.

The placing of topsoil will be measured by the SQUARE METRE for the stipulated topsoil thickness, unless stated otherwise in the Special Provisions.

PAYMENT

751.91 General – Payment for TOPSOIL supplied by the Contractor will be at the Contract Unit Price bid per cubic metre. The Unit Price bid for topsoil supplied by the Contractor shall be accepted as full compensation for all handling, any necessary screening and testing of topsoil, and for delivery and off-loading on the area to be topsoiled.

Payment for TOPSOIL SPREADING will be at the Contract Unit Price bid per square metre. The Unit Price bid for topsoil spreading shall be full compensation for all labour and equipment required for the specified preparation, spreading, and finish grading of the topsoil, and for all incidental work not required to be separately paid for.

Separate prices may be included in the Contract to cover the area preparation work such as:

- clearing and grubbing,
- stripping existing topsoil and removal to stockpile,
- rough grading and fill,
- naturalizing with fine grading,
- rotovating and soil conditioning, and
- trenching for irrigation and sub-soil drainage systems.

CROWNING DETAIL FOR ISLANDS & MEDIANS

SP751-01

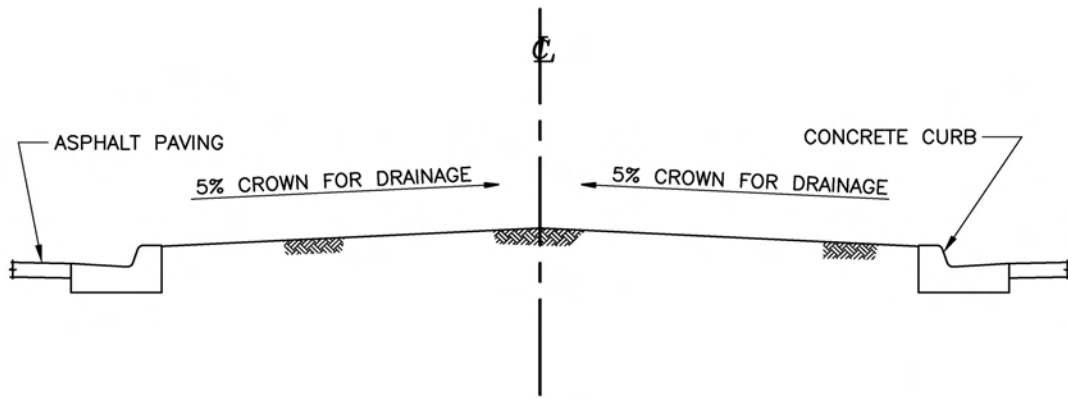

NOT TO SCALE

ALL DIMENSIONS ARE IN MILLIMETRES UNLESS OTHERWISE NOTED

THIS PAGE IS LEFT INTENTIONALLY BLANK

SECTION 754

PLANTING OF TREES, SHRUBS, AND GROUND COVERS

DESCRIPTION

754.01 Scope - This Section refers to those portions of the work that are unique to the supply and planting of trees, shrubs and ground covers, including seeded and sodded areas that are not designated for treatment under SS 757 "Revegetation Seeding". This Section must be referenced and interpreted simultaneously with all other Sections pertinent to the works described herein.

754.02 Related Work - SS 751, Topsoil and Landscape Grading; SS 757, Revegetation Seeding; .

754.03 References - Canadian Standards For Nursery Stock (Canadian Nursery Trades Association), BC Weed Control Act & Regulations, Canada Seed Act, British Columbia Standard for Turfgrass Sod.

754.04 Guarantee/Maintenance

754.04.01 The Contractor shall guarantee and maintain all materials and quality of work for a period of one full year. The guarantee and maintenance period will commence when the following conditions have been met:

- the supply and installation of all plant materials have been completed as per SS 754.43,
- all seeding/sodding has been completed (but is not necessarily yet established) , and
- installation and hydrostatic testing of the irrigation system have been completed as per SS 766.42, and the system is fully operational.

754.04.02 The guarantee includes replacing all plants as determined by the Ministry Representative which are found dead or failing during the entire maintenance and guarantee period. Replacements shall be made immediately unless otherwise directed by the Ministry Representative, and conditions of the guarantee shall apply to all replacement seeding for one full growing season.

Approval of plant material at the source does not preclude rejection of non-conforming stock on the Site prior to, or after planting.

The guarantee shall not apply to plants and planted areas damaged after Acceptance by causes beyond the Contractor's control, such as vandalism, "acts of God", "excessive wear and tear", or abuse.

MATERIALS

754.11 Source Quality Control - The Contractor shall notify the Ministry Representative of the sources of plant materials to be supplied at least two weeks prior to commencing the landscape work. All non-seed plant materials shall be made available for inspection at the nursery by the Ministry Representative upon at least three days notice. Field grown material is not to be dug prior to

inspection.

Approval of plant material at the source does not preclude rejection of non-conforming stock on the Site prior to, or after planting.

Imported plant material shall be accompanied by all necessary permits and import licences, and shall conform to federal and provincial regulations.

It shall be the Contractor's responsibility to ensure that all regulations pertaining to the import of plant materials or their movement to or from a particular region of the province are adhered to, and all inspection certificates required by the Ministry of Agriculture are completed to the satisfaction of that Ministry.

754.12 Transporting Plants to Site

754.12.01 Dormant Period

Deciduous: Bare Root Stock (only in dormant period): Adequate protection shall be given in order to preserve moisture around the root system. For short transit period, four hours or less, maximum temperature in the truck shall not be above 20°C. In all cases, at all times, roots should be protected from frost, wind and sun (e.g., a closed van with wet straw or other suitable packing material protecting the roots). The temperature shall be maintained as uniformly as possible by mechanical means, or in any event to prevent frost damage to roots. The appropriate temperature range shall be between 1°C and 10°C.

Evergreens: It is recommended that root balls not be subjected to freezing temperatures below -5°C for a period longer than four hours. Plants shall be protected to prevent desiccation by wind and sun.

754.12.02 Non-Dormant period - Deciduous and Evergreen plant material shall be transported in a closed van or well-covered truck with a tarp or similar material in order to protect the leaves or needles from windburn. When in transit, with protection of a tarp cover only, it is recommended that foliage be sprayed with an antidesiccant. For the above material in transit for more than three days, it shall be unloaded and then stored away from direct sun for 24 hours to avoid leaf burning.

Sod shall be protected during transportation to prevent drying out and shall arrive at the Site in a fresh and healthy condition.

754.13 Unloading and Handling Procedures - Plants shall be carefully handled to minimize disturbance to root systems and damage to stems and branches. Plants shall not be dropped to the ground when unloading. Plant material that is mishandled and showing evidence of damage to root balls, or undue damage and breakage to top growth will be rejected.

Plants are to be kept in a moist condition at all times. All plants shall be well protected against physical damage and desiccation until they are planted on the Site.

B.R. (Bare Roots) Stock: Roots shall be covered and protected immediately from frost, sun and wind.

Stock in Pots/Containers: Shall be handled as much as possible by pots only in order to reduce breakage of branches/leaves.

Balled & Burlapped (B & B) Material: Plants shall be handled by holding the root ball and supporting the stem to minimize disturbance to the root ball and damage to stems and branches.

Material in Wire Basket: Specimen trees shall be lifted and supported by the wire basket and not by the trunk.

All plants shall be promptly unloaded and their condition checked immediately upon arrival. Watering shall be provided as required and necessary pruning of minor breakage on branches performed.

Protection Against Stem and Branch Damage - During loading, transportation, off-loading and planting, all trees shall be protected against damage to stems and branches. This applies particularly to larger wire-basketed trees.

Bark shall be protected against chafing and cuts by providing a wrapping of cardboard, sackcloth or other material as appropriate and when required.

754.14 Storage

754.14.01 Storage During Growing Season - All plants in containers, balled and burlapped, or in wire basket, if not planted within three days, shall be stored in an upright position in an area providing even light and offering protection from wind and sun scald. Enough space shall be provided between plants so that light reaches all around to the bottom of the plant in order to avoid leaf burning when planted out.

Sod: Sod shall be installed as soon as possible after delivery. If there is a delay of more than 24 hours, the sod shall be properly stored and kept moist and cool until it is placed. Sod shall not be stacked more than three levels high while being stored.

Balled and Burlapped Material: Special attention shall be given to the root ball, and unless weather is rainy or cool, root balls shall be protected by covering with material suitable to protect them from drying out (e.g. sawdust, peat moss, topsoil). Plants intended to be planted in the open shall not be kept stored in a building or any area of low light intensity for a period exceeding seven days. All plants shall be kept well watered and protected from heat and frost.

Containerized Plants: In extreme weather, freezing or high dry heat, the containers shall be buried in a protective medium. Plants intended to be planted in the open shall not be kept stored in a building, truck or any area of low light intensity for a period exceeding seven days during the

growing season.

754.14.02 Storage During Dormant Period - Plants shall be cared for according to each plant's requirement for winter protection, and according to geographical location.

754.15 Plant Material

754.15.01 Species - Selection of species shall be as specified. Every effort shall be made by the Contractor to obtain the plant material specified. Where evidence is submitted that a specified plant cannot be obtained, substitutions in kind, size and grade shall be made upon written approval by the Ministry Representative.

754.15.02 Origin and Requirements - All plant material shall be nursery grown stock or approved collected native plants unless specified otherwise. Plant material will be inspected by the Ministry Representative upon delivery to the Site.

All nursery grown plants shall, as a minimum, comply with the Canadian Nursery Trades Association Specification "Canadian Standards for Nursery Stock" with respect to sizing, grading and quality.

Plants shall be true to name, type and form and shall be representative of their species and variety.

All plants shall be sturdy stock, with tree and shrub heights proportional to trunk caliper, overall plant width and size of root ball, as determined by the Ministry Representative. Plants that are weak and thin, and those showing effects of being grown too closely together or poorly maintained, will not be accepted.

Plants shall be vigorous and healthy with normal, well developed branches and good fibrous root systems and be free from decay, physical injury, disease and insect damage and infestation.

In particular, conifers shall have a healthy, single leader with well shaped whorls of vigorous, newly growing branches and shall exhibit natural growth habit characteristic of the species and variety. Trees sheared as Christmas trees are not acceptable.

The root balls of dug material and the soil of containerized plants shall be free from pernicious perennial weeds. All balled and burlapped plant stock shall be supplied in biodegradable root ball sacking.

The search area for plants shall include, but not necessarily be limited to, the provinces of British Columbia, Alberta and the states of Washington, Oregon, California (northern portion), Idaho and Montana. All plant material being sourced from milder areas shall be properly "hardened off" prior to shipping and planting.

754.15.03 Nursery Grown Stock - All plants specified "Container" shall be grown for the length of time necessary to permit the roots to fill and hold the soil within the container, as required by the Canadian Standards for Nursery Stock.

Similarly, all field dug material will show evidence of having been root pruned to encourage fibrous root system development and resulting in root balls that retain their integrity during handling.

Forestry seedlings shall be supplied and handled in accordance with the requirements of the Silvicultural Manual, Ministry of Forests, Province of B.C., 1993. This manual can be found on the Internet at:

<http://www.for.gov.bc.ca/hfp/pubs/silvman/index.htm>

All plant material shall be appropriately identified and individually labelled with weatherproof tags. In the case of small containerized plants such as ground covers and bundled bare root seedlings, which are supplied in large numbers, labelling shall be limited to identification of group lots as permitted by the Ministry Representative.

754.15.04 Collected Plant Stock - The Contractor shall provide either permits or verification that permission was obtained for collecting native and/or introduced plant materials. Information shall be supplied on where, when and how collection was made.

All collected plant material shall have been grown and maintained in a nursery environment for a minimum of one growing season, unless, at the sole discretion of the Ministry Representative, certain species are approved for a lesser period of time. As for nursery grown stock, collected plants shall be held long enough prior to planting to allow roots to fill the container or the dug root ball and to retain the soil within.

Collected plant stock shall be appropriately labeled with weather proof tags for easy identification at the job site.

754.15.05 Seed - Seed quality and type shall conform to that specified in the Special Provisions.

All other requirements are per SS 757 Revegetation Seeding.

754.15.06 Sod - Sod shall be nursery grown, true to type and conform to the British Columbia Standard for Turfgrass Sod, and the general requirements of the Canadian Standards For Nursery Stock.

Sod grade shall be as specified in the Special Provisions.

754.16 Water - Water shall be clean and potable and shall be supplied by the Contractor.

754.17 Fertilizer - Fertilizer shall comply with the provisions of the Canada Fertilizers Act and Fertilizer Regulations. Fertilizer shall be supplied to the specifications in the Special Provisions.

754.18 Bark Mulch - Bark mulch shall be sized 25 mm and minus, Douglas Fir or Hemlock bark chips and fines, or a combination of both types and of the quality used for decorative landscape mulching purposes. It should be free of chunks and sticks, dark brown in colour and free of all soil, stones, roots or other extraneous matter.

754.19 Backfill Topsoil - Backfill topsoil for planting

operations shall conform to the requirements of SS 751 - Topsoil and Landscape Grading.

754.20 Other Materials - When required, various other materials such as soil amendments, erosion control products, hydraulic mulches, etc. shall be supplied to the specifications in the Special Provisions.

CONSTRUCTION

754.31 Scheduling - Work shall be scheduled to meet the milestone dates provided in the Special Provisions, and to ensure its execution meets the requirements of living plant material.

The work shall be co-ordinated with the schedule of other trades, and be well integrated with other specific requirements such as Sediment and Drainage Management Drawings, which may be provided for any given project.

754.32 Preplanting Operations - The plant material shall be approved by the Ministry Representative prior to installation. The Contractor shall ensure that all requirements of SS 754.11 through SS 754.15 have been met and that any minor damage to plant stock is taken care of through appropriate pruning or other measure. When directed by the Ministry Representative, the Contractor shall apply anti-desiccant to large conifers and deciduous trees that are in leaf. Application will be in accordance with the manufacturer's instructions for the particular product.

754.33 Location of Planting - Locations, quantities and spacing of trees, shrubs, vines and groundcovers as shown on the Drawings shall be considered approximate and may be adjusted by the Ministry Representative to meet field conditions. Tree numbers, spacings and locations will vary according to the Site conditions and amenities. The Contractor may adjust plantings to meet field conditions, with the concurrence of the Ministry Representative. Locations shall be staked as shown on the Drawings and verified on Site with the Ministry Representative prior to planting. If underground obstructions are uncovered they shall be reported to Ministry Representative for resolution.

754.34 Area Preparation

754.34.01 Finish Grade Preparation - The Contractor shall verify that grades are correct. If discrepancies occur, the Ministry Representative shall be notified and work shall be halted until otherwise instructed by the Ministry Representative.

754.34.02 Planting Beds and Grass Areas - Prepare planting beds and grass areas in accordance with SS 751 - Topsoil and Landscape Grading.

754.34.03 Planting Holes - Planting holes shall be dug in accordance with the specific requirements described below. The bottom of planting holes shall be scarified and loosened to a depth of 100 mm prior to placement of plants and backfill soil.

Subsoil, rocks, roots and extraneous material shall be removed from excavated material that will be used as

planting backfill soil. Unsuitable or excess material shall be disposed of.

Holes dug by a mechanical tree spade shall have their sides scarified to loosen any compaction glazing caused by the blades. Planting holes shall be tested by filling with water. Inadequate drainage conditions permitting the retention of water in planting pits for more than 12 hours shall be reported to the Ministry Representative before proceeding with the work.

i) Free Draining Sub-Grade: Where the subgrade and existing native surface soils are of good drainage and of a non-compacted nature, planting holes shall be excavated and prepared to allow the following depth of topsoil backfill underneath and around the root ball:

- For plants up to and including 27 cm (#5) pot size - not less than 150 mm .
- For plants larger than 27 cm (#5) pot- size not less than 300 mm

ii) Poor Draining Sub Grade: Where the subgrade and existing native surface soils are of poor texture and conditions are generally compacted, planting holes shall be excavated and prepared to allow the following depth of topsoil backfill underneath and around the root ball:

- For plants up to and including 27 cm (#5) pot size not less than 300 mm
- For plants up to 45 cm pot size - not less than 450 mm
- For tree root balls larger than 45 cm - not less than 600mm

If severely compacted conditions are encountered, and surface or ground water entering the excavations does not drain, the Contractor shall correct the problem by;

- providing a means of sub-surface drainage
- utilizing elevated planting techniques where some of the planting soil will be placed into a partial excavation and the remainder on the surface to meet the depth requirement for growing medium, or
- considering alternate planting sites.

These alternatives shall receive prior approval by the Ministry Representative, as applicable to the Site.

754.35 Time of Planting - All planting operations shall be performed during the normal planting season for each type of material, and within the milestone dates provided in the Special Provisions, unless otherwise authorized in writing. During the specified timeframe, plant operations shall, as far as practicable, take advantage of soil and weather conditions favourable to the work.

Planting into frozen ground is not acceptable.

754.36 Planting Procedures - Trees and Shrubs

General Procedure - Plants shall be installed so that after settlement they will be at the same planting depth they were

at in the field or in containers. The soil mark on the stem is an indication of this, and it shall be flush with the finished level allowing for settling of the topsoil after planting and settlement. The entire root ball shall be covered with growing medium.

Once the bottom of the planting hole is scarified and the initial lift of backfill topsoil is placed, the holes shall be pre-watered and allowed to drain prior to installation of plant material.

Plants shall be set plumb in the planting beds or in the centre of the pits except where the plant's character requires variation from this.

The growing medium shall be placed in layers around the roots or ball, preferably by hand. Each layer shall be firmed to eliminate air void and ensure good soil contact with the roots. The process shall be carried out carefully to avoid injuring the roots or ball, or disturbing the position of the plant.

Trees requiring staking shall have support stakes placed carefully between the roots before backfilling. Specifications for tree supports are described in SS 754.

After the planting hole is filled with soil to ground level, the plant shall receive a thorough watering. A final backfill layer shall be applied to form a saucer-like berm around the circumference of the planting hole in order to catch and hold rainwater. This rain basin shall be maintained until final acceptance of the work.

Once planting and mulching is complete, the Site shall be cleaned of all excess soil, rock and debris.

Specific Planting Requirements:

Bare Root Stock - The roots of bare root plant material shall be soaked in water prior to planting. During installation, the plant roots shall be evenly spread out over a cone of soil in the bottom of the hole, and the plant supported to the correct depth as backfilling takes place. The plant shall be gently shaken in a vertical motion to ensure that soil particles sift into the root system and establish close contact with the roots

Container Stock - Non-perishable, impervious containers such as plastic pots and tubs shall be removed from plants before planting. Once plants are removed from these containers, root systems shall not be disturbed with the exception of unraveling any roots starting to spiral around the root ball.

Bio-degradable containers such as peat or paper fibre pots shall not be removed before planting, but shall be thoroughly soaked with water prior to placement in the holes. This will ensure that containers absorb subsequent watering and not repel it due to the presence of a dry barrier. The rim of such containers shall be not be exposed to the air, and when necessary, shall be removed after planting.

Balled and Burlapped Stock - When backfill soil is placed to approximately two-thirds of the root ball height, the ties

on the sacking shall be cut and the top portion of the burlap folded back carefully to avoid disturbing the integrity of the root ball. The sacking shall not be removed. The remainder of the hole will then be backfilled and firmed.

Where wire baskets are used to encase and support the root ball of supplied plant material, these shall not be removed. The top of the wire basket shall be cut away or completely folded back and buried without disturbing the integrity of the root ball.

Forestry Seedlings - Planting of forestry seedlings shall be in accordance with the Silviculture Manual of the British Columbia Ministry of Forests and Range.

Tree Support - All trees of a size requiring staking or guy wiring shall be supported in accordance with the details and instructions provided on Drawings SP754-04 through SP754-07 of these Standard Specifications. All hardware required shall be installed without damage to plants.

Trees that are dislodged during the contract period shall be uprighted and re-secured as required. Trees that are damaged shall be replaced by the Contractor at the Contractor's expense.

754.37 Seeding - Application of seed, fertilizer, and other materials shall be at the rates specified in the Special Provisions.

The requirements for construction shall be in accordance with SS 757 Revegetation Seeding.

754.38 Sodding - The required fertilizer shall be applied at the rates specified in the Special Provisions, and worked well into the topsoil prior to laying the sod.

Sod shall be laid within 24 hours after delivery unless proper storage arrangements can be made.

The sections of sod shall be laid close together with joints staggered. No open joints are to be visible, and no pieces are to overlap.

Sod shall be laid smooth and flush with the adjoining grass areas, adjacent hard surfacing, and the tops of curbs and planting bed liners, unless otherwise shown on the Drawings. All necessary cutting shall be done using sharp implements.

On slopes of approximately 2.5 to 1 and steeper, the sod shall be laid lengthwise across the slope, and the material secured with wooden stakes driven flush with the sod at intervals not exceeding 0.5 metres. There shall be at least three stakes per individual sod piece. On slopes of gradients between 2.5 and 1.5 to 1, the bottom three rows of sod and every third subsequent row shall be secured with stakes. For slopes steeper than 1.5 to 1, every sod course shall be staked.

Sodded areas shall be rolled or suitably tamped to ensure a good bond with the topsoil, and then subsequently protected from heavy foot traffic or equipment travel.

Unless otherwise indicated, sodded areas shall be evenly

watered within 12 hours of installation, and with sufficient quantity to saturate the grass and the upper portion of the topsoil.

754.39 Watering - All trees, shrubs, groundcovers, vines, and designated grass areas, shall be watered immediately after planting, and regular watering shall continue as required for plant health until final acceptance of the work.

754.40 Pruning - Pruning shall be limited to the minimum necessary to remove dead or injured tissue and branches interfering with desirable growth habit and overall health of the plant.

Pruning shall be done in accordance with proper horticultural practice, using clean, sharp tools appropriate to the task and in a manner that preserves the natural character of the plant.

754.41 Mulching - When specified in the Drawings and Special Provisions, individual tree pits and planting beds shall be mulched.

Mulching of tree pits and planting beds shall be carried out after watering, to an even depth of 50 mm after settlement, unless otherwise specified on the Drawings and in the Special Provisions.

754.42 Clean-up - All plant containers and waste materials resulting from landscaping and planting operations shall be removed from the Site and appropriately disposed of.

754.43 Conditions for Acceptance - The Contractor shall ensure that the following conditions are met for all planted and grassed areas:

- a) Topsoil quality, fertility levels, depths and surface conditions are as set out in the Drawings and Specifications;
- b) All plants are of the species and varieties specified and planted in the locations shown on Drawings;
- c) All plants are healthy and growing vigorously. Seeded grass areas are sufficiently established into the underlying growing medium, are free of thin and bare patches, and are relatively free of weeds: not more than 5% in lawn areas, and not more than 15% in rough grass areas;
- d) The water content in the topsoil, i.e. – when irrigation is provided, is to the satisfaction of the Ministry Representative;
- e) Trees are supported, as specified;
- f) Pruning is complete, in accordance with proper horticultural practice and to the satisfaction of the Ministry Representative;
- g) All planting beds and tree pits are free of weeds;
- h) Mulch is in place, as required and;
- i) Unmulched areas are cultivated to leave a loose, friable, water-permeable surface;
- j) Maintenance procedures set out in SS 754.71 have been carried out.

MAINTENANCE

754.71 Maintenance - The following maintenance operations shall be performed from the time of landscape installation, until the expiry of the landscape maintenance period as defined in the contract documents:

- a) When specified, water shall be applied in sufficient quantity and by appropriate method to maintain optimum soil moisture conditions for healthy plant establishment, without causing surface soil erosion.
- b) Weed control will be carried out, as required to prevent competition with establishing planted material and to maintain the aesthetic appearance of landscaped areas. The presence of weeds in plantation beds, individual planting pits, and designated lawn areas, is limited to a maximum of 5% of the surface area at any given time, unless otherwise stated in the Special Provisions. The use of herbicides for the control of weed growth is not permitted.
- c) Mowing shall be carried out at regular intervals, as required, to maintain grass in the areas designated, and at the height(s) specified in the Special Provisions. Edges of areas designated "Lawn" shall be neatly trimmed. Excess clippings shall be removed immediately after mowing and trimming.
- d) Fertility levels in planted and grassed areas shall be maintained in accordance with the requirements of the plant material.
- e) Bark Mulch shall be maintained to the specified depth.
- f) For non-mulched areas, the soil surface shall be cultivated, as required, to keep it loose and friable.
- g) Insect and disease control shall be carried out as required by the Contractor with approval of the Ministry Representative. The Contractor shall secure all necessary Pesticide Use Permits in accordance with Ministry of Environment (MoE) regulations, and possess a valid Pesticide Service License. When required, the Contractor shall provide a Pesticide Management Plan to MoE.
- h) Establishment pruning to encourage proper shape and health of plants by removing dead, or broken and interfering branches and diseased or damaged tissue.
- i) Maintenance of tree stakes, guy wires and tree ties to prevent plant dislodgement and damage to trunk and branches.
- j) All plant material shall be alive and maintained in a healthy growing condition during the entire establishment

period. Plant material which has died or is not healthy, and in the opinion of the Ministry Representative, does not perform its function, will be removed and replaced by the Contractor at the earliest opportunity, weather and season permitting. Grassed areas that show deterioration or bare spots shall be repaired immediately. Unless otherwise directed by the Ministry Representative, all repair and/or replacement shall be in accordance with the original specifications and requirements.

The landscape maintenance period may run concurrently, in whole or in part, with the contract warranty period.

MEASUREMENT

754.81 Planting - The unit of measurement for plants will generally be PER PLANT, unless otherwise specified in the Special Provisions.

754.82 Seeding and Sodding - The unit of measurement for seeded and sodded areas will generally be by the SQUARE METRE, unless otherwise specified in the Special Provisions.

754.83 Mulch - The unit of measurement for supply and installation of bark mulch will generally be by the SQUARE METRE for the stipulated mulch thickness, unless otherwise specified in the Special Provisions.

PAYMENT

754.91 General - Payment for plants will be at the contract unit prices bid for PLANTING of the types, species and sizes called for, and shall constitute full compensation for supplying and delivering plants; for supplying and delivering topsoil for plant backfill, fertilizer and all incidental materials; for digging holes for plants; for planting, pruning, staking and guying, mulching, rain basinformation, clean up after planting and maintenance of plants; and for all labour, equipment and tools and incidentals necessary to complete the work prescribed in this Section.

Payment for SEEDING and SODDING will be at the contract unit price bid per square metre. The unit price shall be full compensation for work described and all work subsidiary and incidental thereto for which separate payment is not elsewhere provided.

Payment for MULCHING will be at the contract unit price bid per square metre. The unit price bid for mulching shall be full compensation for all labour and equipment required for supplying and spreading of the mulch and for all incidental work not required to be separately paid for.

PLANTATION EDGING DETAIL

SP754-01

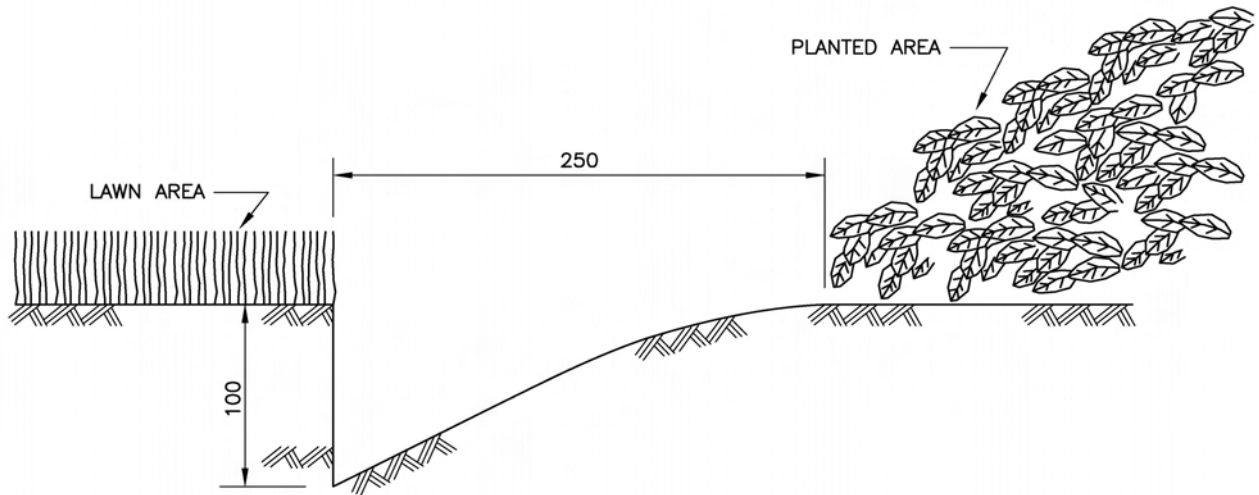

NOT TO SCALE

ALL DIMENSIONS ARE IN MILLIMETRES UNLESS OTHERWISE NOTED

TREES WITHIN LAWN AREAS

SP754-02

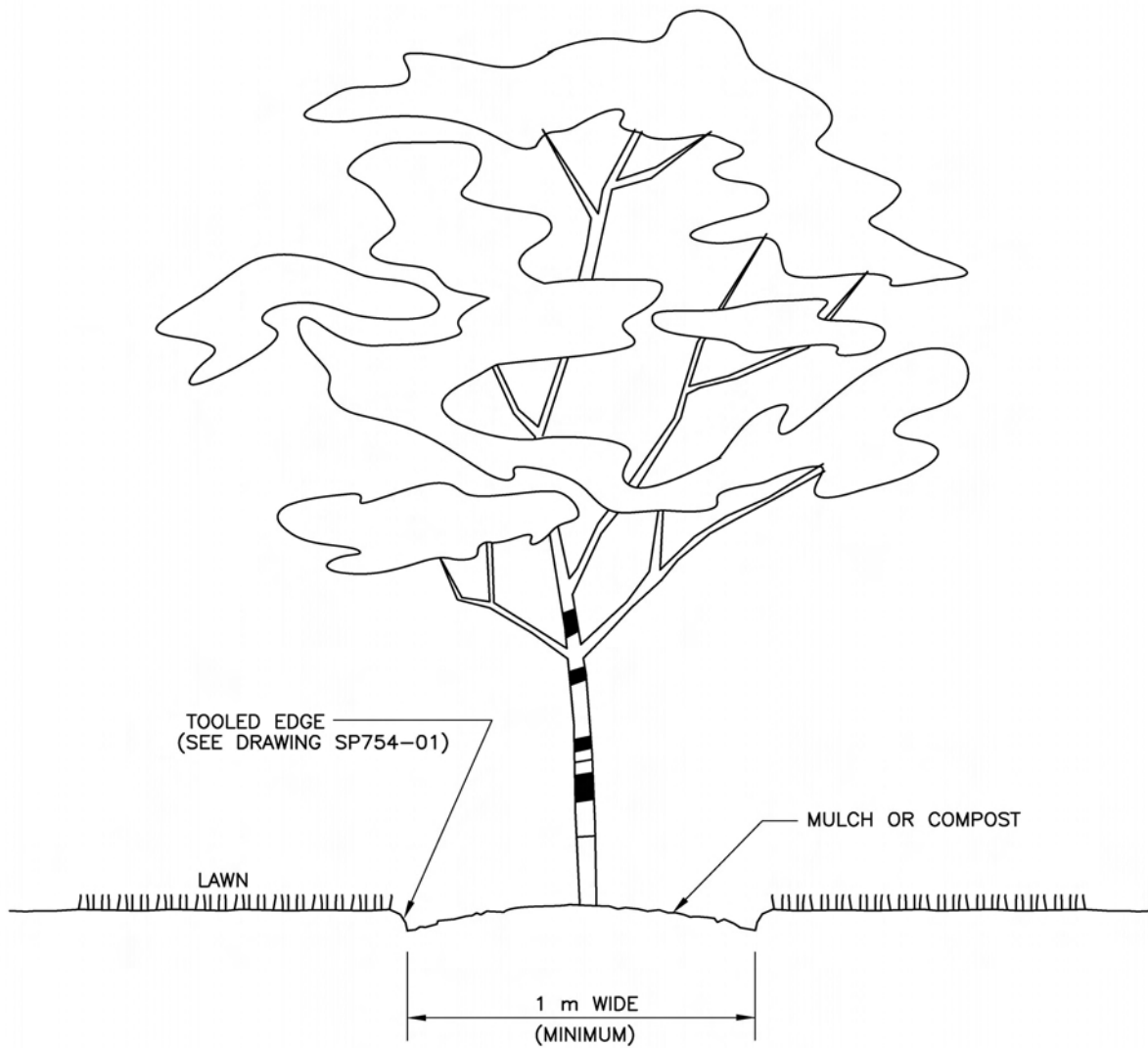

NOTE:
MAINTAIN VEGETATION FREE BASE

NOT TO SCALE

ALL DIMENSIONS ARE IN MILLIMETRES UNLESS OTHERWISE NOTED

CEDAR LINER DETAILS

SP754-03

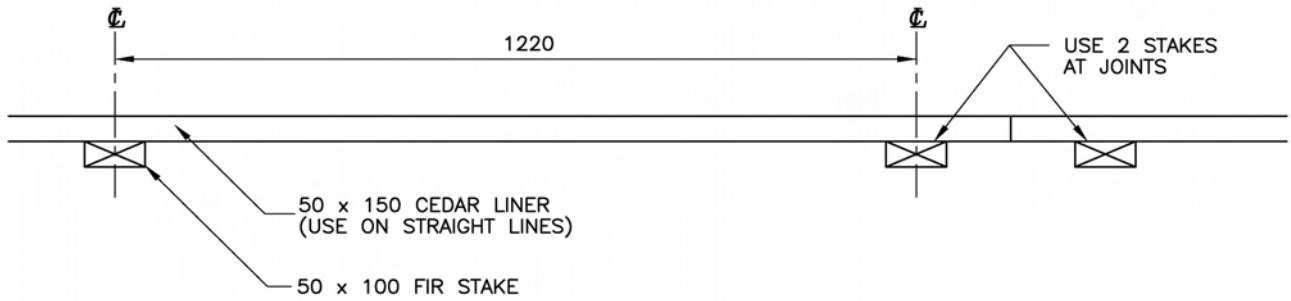

PLAN

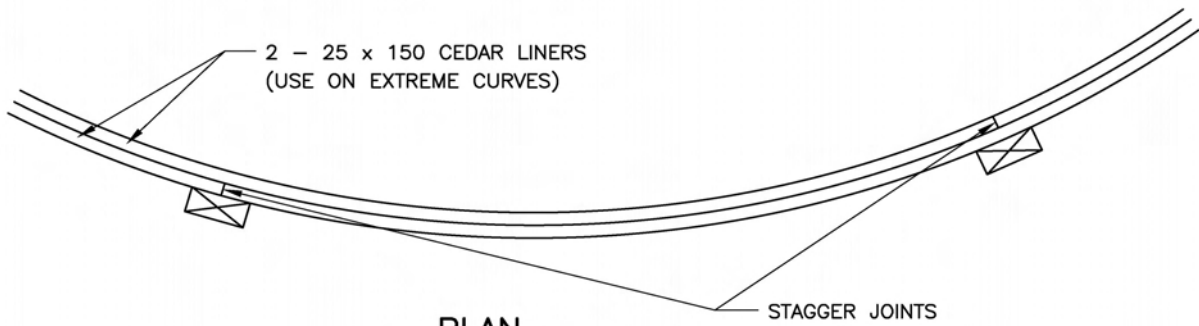

PLAN

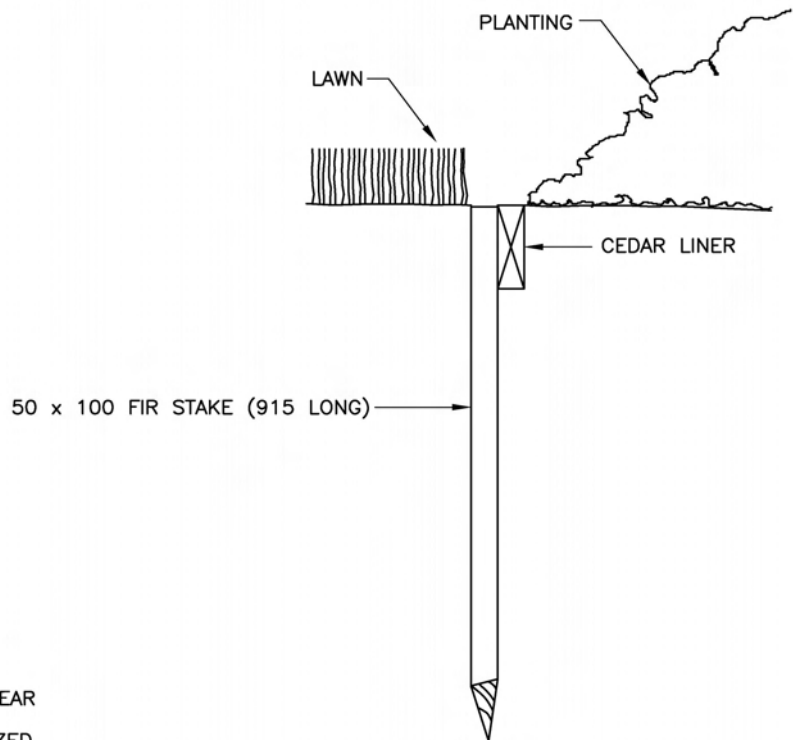

SECTION

NOTES:

1. ALL WOOD TO RECEIVE 2 COATS CLEAR CREOSOTE PRIOR TO CONSTRUCTION
2. ALL NAILS TO BE HOT-DIP GALVANIZED, 75 mm LONG

NOT TO SCALE

ALL DIMENSIONS ARE IN MILLIMETRES UNLESS OTHERWISE NOTED

TRIPOD BRACING DETAIL

SP754-04

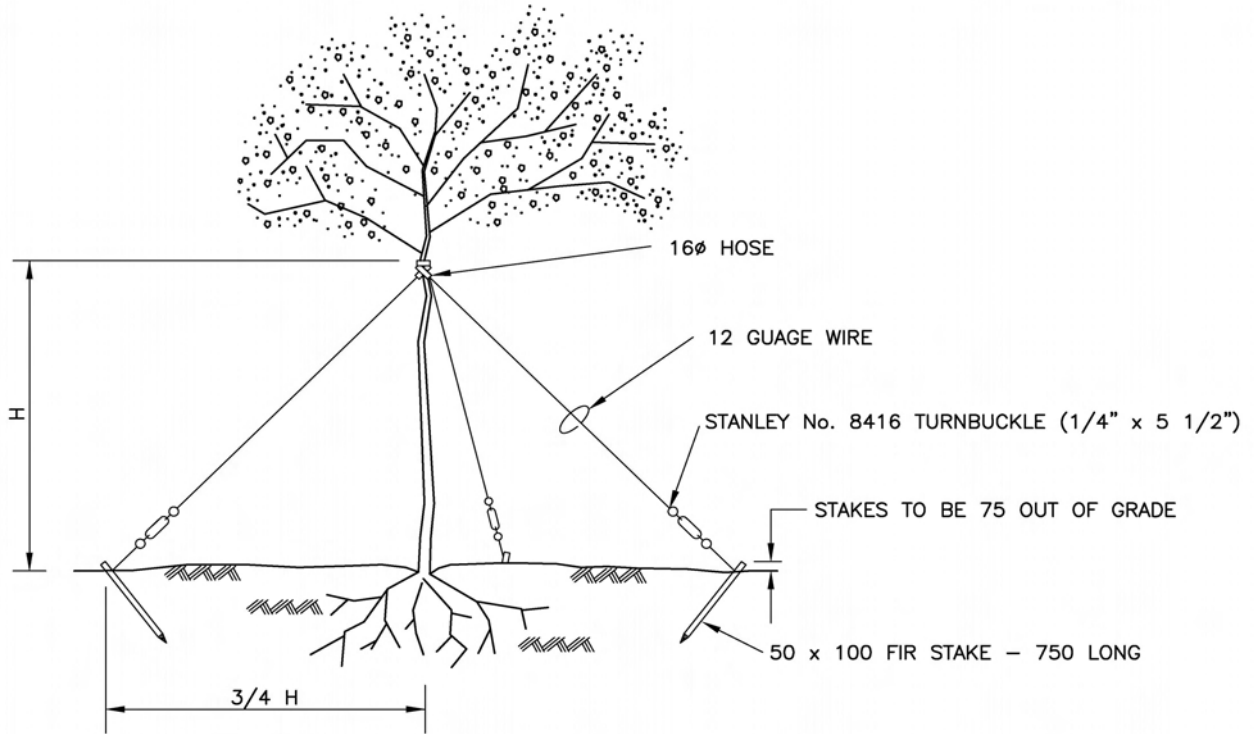

FOR DECIDUOUS TREES
WHEN SPECIFIED

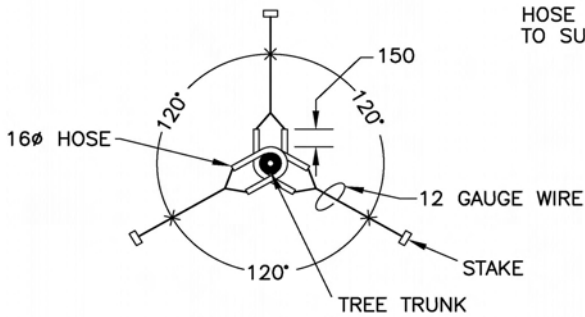

PLAN VIEW

TURNBUCKLES NOT SHOWN FOR CLARITY

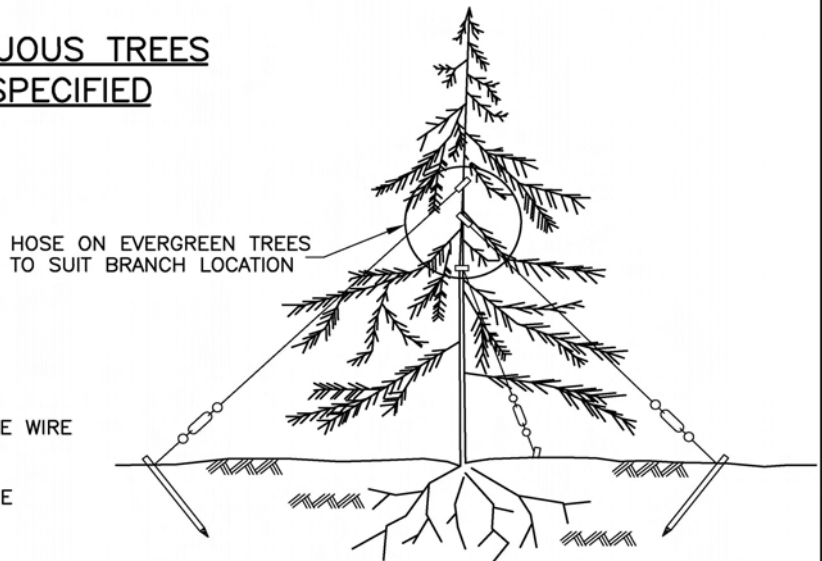

FOR CONIFEROUS TREES
WHEN SPECIFIED

NOTE:
TIGHTEN WIRE BY ADJUSTING TURNBUCKLES

NOT TO SCALE

ALL DIMENSIONS ARE IN MILLIMETRES UNLESS OTHERWISE NOTED

DOUBLE TREE STAKES FOR TREES OVER 3 m HIGH

SP754-05

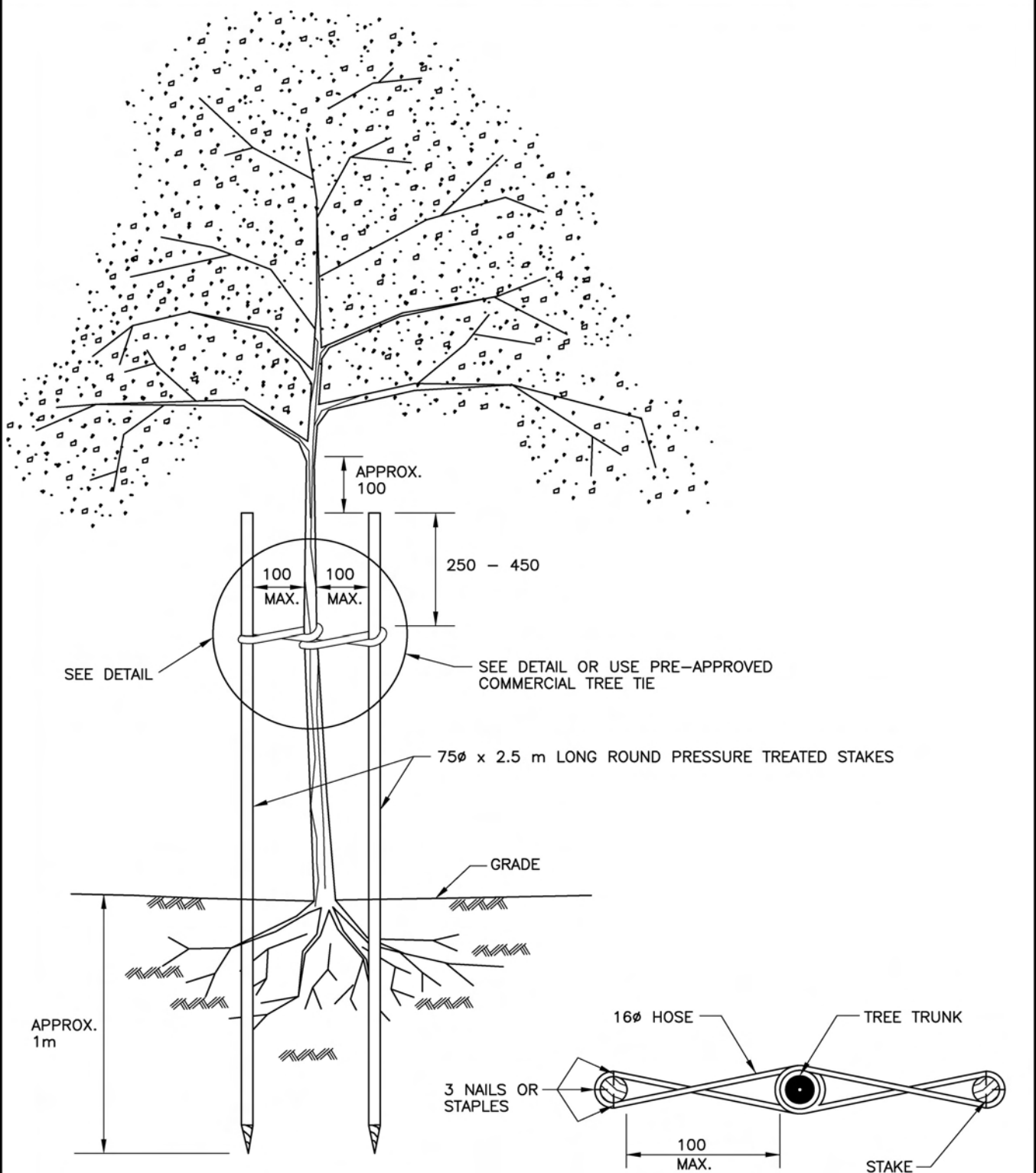

ELEVATION

DETAIL

NOT TO SCALE

ALL DIMENSIONS ARE IN MILLIMETRES UNLESS OTHERWISE NOTED

SINGLE TREE STAKE FOR TREES 1.5 m TO 3 m HIGH

SP754-06

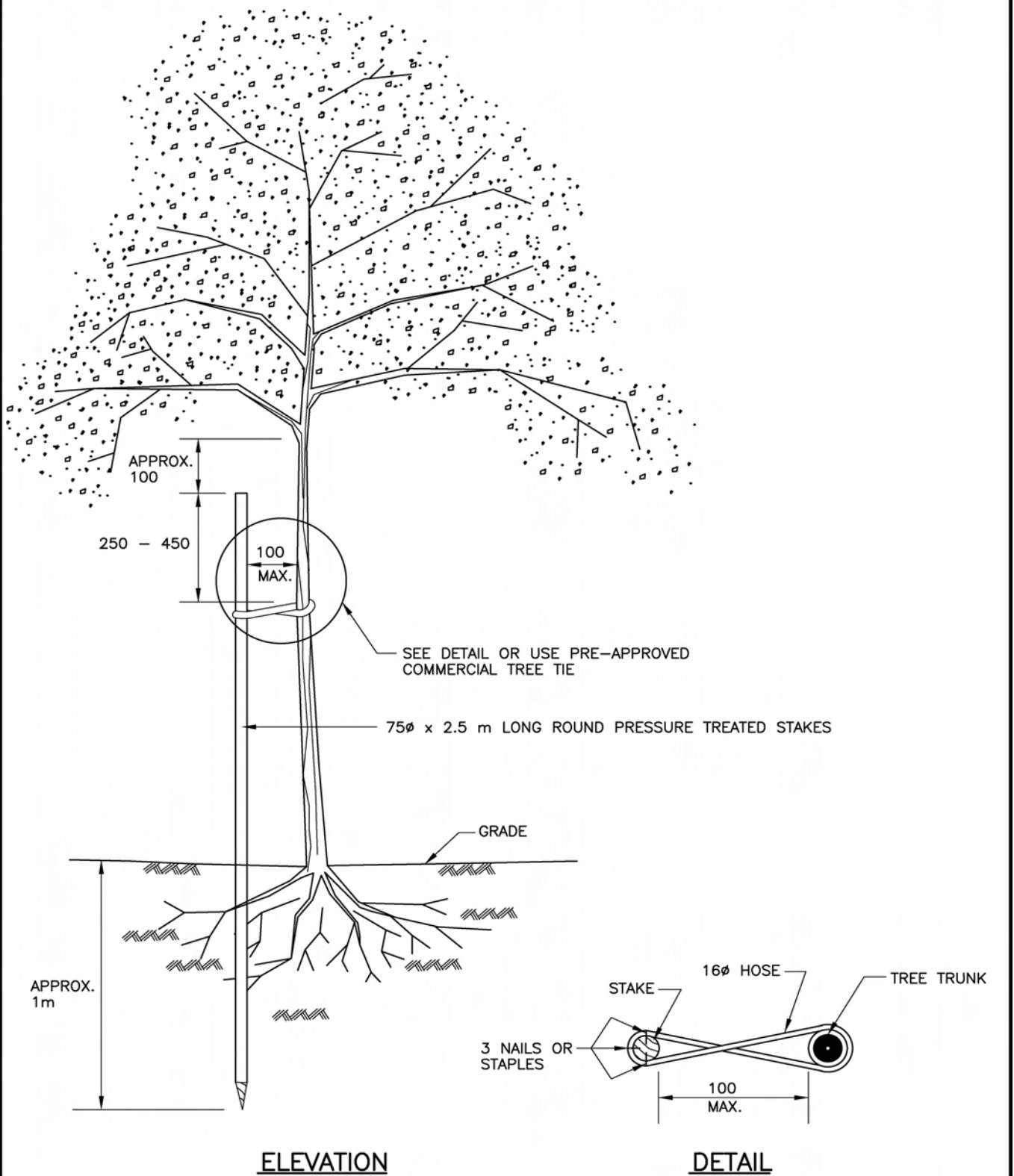

NOT TO SCALE

ALL DIMENSIONS ARE IN MILLIMETRES UNLESS OTHERWISE NOTED

DOUBLE TREE STAKES FOR BOULEVARD PLANTING AREAS

SP754-07

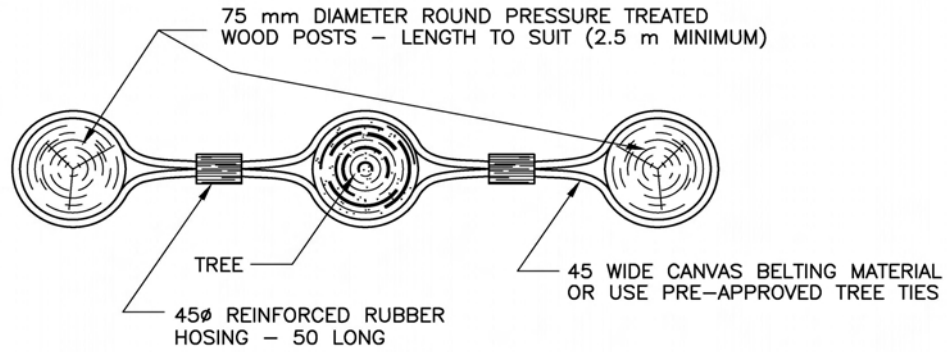

CROSS SECTION

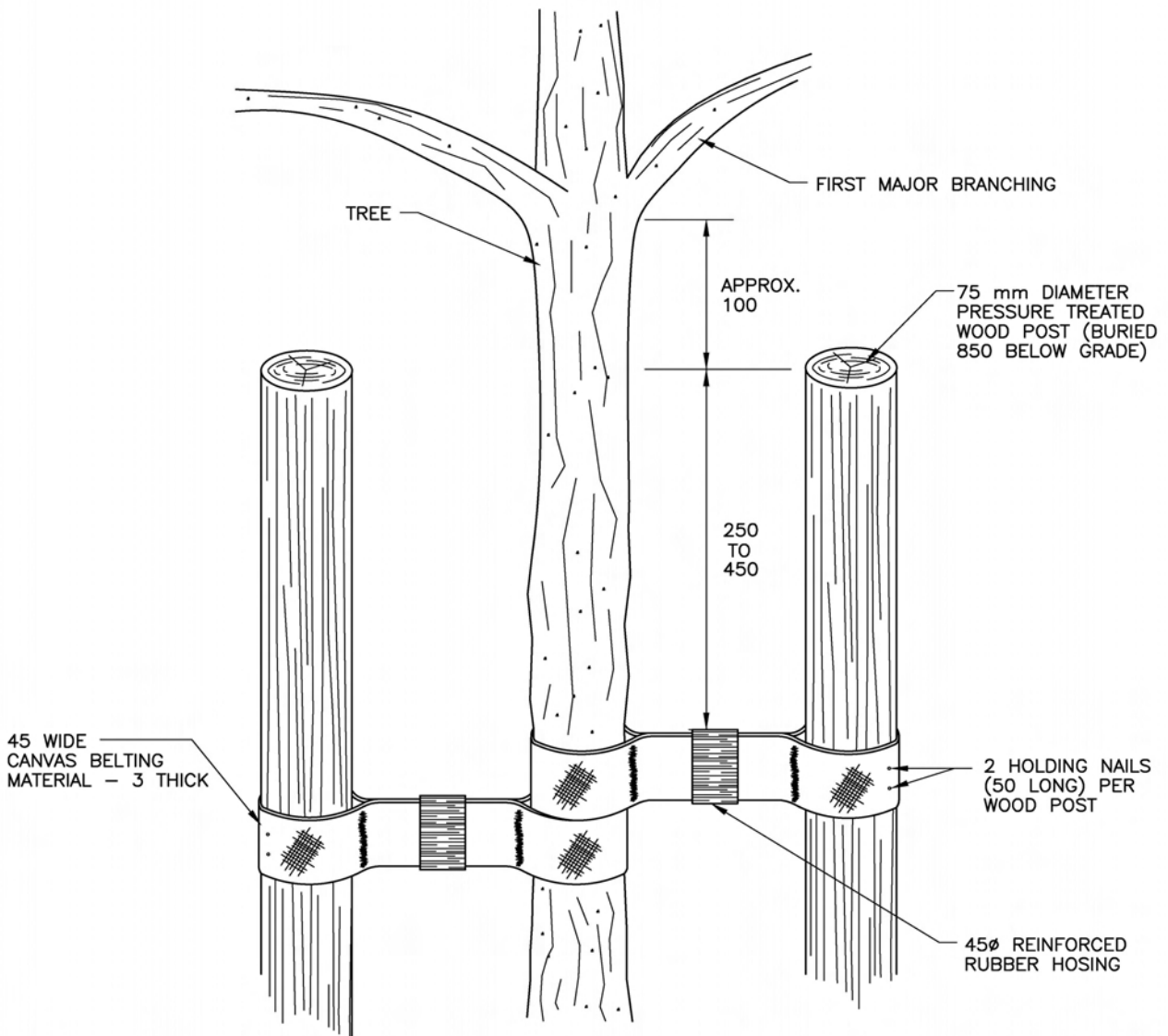

NOT TO SCALE

ALL DIMENSIONS ARE IN MILLIMETRES UNLESS OTHERWISE NOTED

THIS PAGE IS LEFT INTENTIONALLY BLANK

SECTION 757

REVEGETATION SEEDING

DESCRIPTION

757.01 Scope - This Section refers to those portions of the work that are unique to the supply and application of seed, fertilizer, mulch, tackifier, and other materials used for revegetating disturbed areas, and that are not designated for treatment under SS 754, Planting of Trees, Shrubs, and Ground Covers. This Section must be referenced and interpreted simultaneously with all other Sections pertinent to the works described herein.

757.02 References - Guidelines for Hydroseeding in Proximity to Hydro Lines, Canada Seed Act, and BC Weed Control Act & Regulation.

MATERIALS

757.11 Handling and Storage - All seed, mulch, fertilizers and other dry materials shall be stored in a dry, weather proof storage place and shall be protected from damage by heat, moisture, rodents or other causes until the time of seeding. Supplier labels or other identification are not to be removed or defaced.

757.12 Seed

757.12.01 Supply of Seed - All seed specified shall be supplied by the Contractor and obtained from a recognized source.

757.12.02 Seed Type and Grade - All seed supplied either as individual species, or as a seed mix, shall comply with the requirements of the Canada Seed Act and Regulations, and the grade standards for that particular crop kind. Grass and legume seed shall meet or exceed Common No.1 grade prior to mixing with other species. Seed shall be free of propagules of plant species designated as noxious weeds under the BC Weed Control Act & Regulations.

All legume seed shall be inoculated with an adapted bacterial culture to ensure nitrogen fixation.

Seed mixes used for general roadside revegetation, and for the general conditions and areas indicated, shall be as shown on the table "Standard Grass Seed Mixes and Material Application Rates For Revegetation of British Columbia Highway Roadsides", unless otherwise specified in the Special Provisions.

When specified, wildflower and shrub seed shall be supplied to the requirements of the Special Provisions.

757.12.03 Seed Analysis Report - The Contractor shall provide valid Certificates of Analysis for each species and seed lot used in a mix at least five working days prior to the blending of mixes and shipping of the seed from the seed supplier to the Contractor. The Certificates of Analysis shall set out details of the seed as specified in the "Canadian Methods and Procedures for Testing Seed".

The Ministry Representative will review the Certificates of Seed Analysis and, if the specifications are met, give the Contractor approval to proceed with blending and seed use.

757.12.04 Packaging and Labelling - Seed shall be supplied in the original sealed packages, with legible labels securely attached, and providing the following information:

- Supplier's name and address
- Analysis of seed mixture – the grade, and the name and percentage by weight of individual seed species
- Percentage of Pure Live Seed (PLS) for each species
- Lot number and crop year for each species in the mix
- Net weight (mass)
- Date and location of packaging

757.13 Fertilizer - Fertilizer shall comply with the provisions of the Canada Fertilizers Act and Fertilizer Regulations. Fertilizer shall be supplied as noted on the table "Standard Grass Seed Mixes and Material Application Rates For Revegetation of British Columbia Highway Roadsides" unless otherwise specified in the Special Provisions. All fertilizer shall be a coated, slow release Nitrogen type formulation.

757.14 Hydraulic Mulch - Hydraulic mulch shall be a wood fibre type, specifically designed for hydraulic seeding, and having demonstrated satisfactory past performance for this purpose. The product shall be dyed green for appearance and ease of monitoring application.

Mulch shall be supplied in packages bearing the manufacturer's label, clearly indicating the weight and product name.

Mulch may contain a tackifier, which shall adhere to mulch to prevent separation during shipment and to avoid chemical agglomeration during mixing in hydraulic mulching equipment.

757.15 Tackifier – Tackifier that is separately supplied shall be an organic guar gum or starch base product specifically designed for use in hydraulic mulching and/or seeding operations. The tackifier shall be supplied in packages bearing the manufacturer's label, clearly indicating product name, content and application instructions.

757.16 Water - Water used for hydraulic seeding operations shall be free of impurities that would inhibit germination and growth or may be harmful to the environment. Unless otherwise noted in the Special Provisions, the Contractor shall be responsible for securing a water source for hydraulic application of materials, including obtaining use permits under the Water Act if

SECTION 757

REVEGETATION SEEDING

water is to be drawn from waterbodies, and for all cost to supply.

757.17 Other Materials - Bonded Fiber Matrix coverings, erosion control blankets, soil amendments and other materials shall be supplied to the specifications in the Special Provisions.

EQUIPMENT

757.21 General - Equipment used shall be capable of applying the materials listed in the Special Provisions uniformly over the designated areas.

Equipment shall not cause soil rutting or other site damage.

757.22 Hydraulic Seeding/Mulching Equipment - Equipment shall have the tank volume identified by an identification plate or sticker, which shall be affixed in plain view.

The hydraulic seeder/mulcher shall be capable of sufficient agitation to mix the materials into a homogenous slurry, and to maintain the slurry in a homogeneous state until application.

Equipment shall be adequately sized to the task, to complete work efficiently within the time frame specified, and to permit application of materials without excess water being applied, or undue time lapse between operations. Hydraulic mulchers should be capable of producing slurry viscosities containing approximately 18 to 30 kg of mulch per 500 litres of water.

Extension hoses or pipes shall be provided to reach areas not accessible from the hydraulic seeder.

CONSTRUCTION

757.31 Scheduling - Work shall be scheduled to ensure a minimum duration of on-Site storage of materials, minimum compaction of topsoil, and prompt mulching operations.

The work shall be co-ordinated with the schedule of other trades, and be well integrated with specific requirements such as Sediment and Drainage Management Plans, which may be provided for any given project.

757.32 Protection - Existing Site equipment, roadways, landscaping, reference points, monuments, markers, utilities and structures shall be protected from damage by hydraulic application method. No overspray is to occur into waterbodies or environmentally sensitive areas. When necessary to ensure protection of these areas, dry, hand broadcasting of materials will be employed.

757.33 Timing of Material Application - Material application shall be carried out in accordance with the construction schedule.

757.34 Methods - The methods chosen for material application shall be at the Contractor's discretion, unless otherwise specified in the Special Provisions.

757.35 Rates of Application - Material application rates shall be in accordance with Table 757.1 unless otherwise directed by the Ministry Representative.

757.36 Record of Application - The Contractor shall maintain a record of all pertinent application information on the form accepted by the Ministry Representative. Refer to Sample Form "Daily Seeding/Application Record".

757.37 Application Method for Mechanical Drop or Broadcast Dry Seeding - Seed shall be applied in two intersecting directions, except where conditions dictate seeding in one direction only.

Seeding shall overlap adjoining ground cover by 300mm.

757.38 Hydraulic Application of Materials

757.38.01 General - The hydraulic seeder/mulcher shall be operated in compliance with Ministry safety standards including those detailed in the publication "Guidelines for Hydroseeding in Proximity to Hydro Lines."

Materials shall not be sprayed on objects not expected to support plant growth. No overspray is to occur into waterbodies or environmentally sensitive areas.

The Contractor shall be responsible for any overspray or damages incurred during hydroseeding. Any overspray or damage shall be made good at no cost, to the satisfaction of the Ministry Representative.

757.38.02 Mixing - The required quantities of seed, fertilizer, mulch, tackifier and other material shall be charged into the tank accurately by weight or by an acceptable system of mass calibrated volume measurement.

The materials shall be thoroughly mixed into a homogeneous water slurry prior to application.

All seed shall be added last when mixing. Pellet inoculated seed shall be applied immediately after placement into tank, and if this is not possible, dry application methods must be used. Other seed shall not be left in the tank for unreasonable lengths of time prior to application, i.e. - exceeding one or two hours, particularly when in contact with fertilizer solution.

The Ministry Representative will determine if Seed that remains in the tank for periods longer than specified can be used. Rejected seed shall be replenished with fresh stock.

757.38.03 Application - The mulch and tackifier components of hydraulically applied mixtures will generally be applied in stages. The initial pass of the hydraulic seeder will distribute the correct amount of seed and fertilizer for the area being done, as well as up to one third of the required mulch/tackifier. The subsequent pass(es) will complete the mulching/tacking process to the required rate.

Mulch shall be applied to form an even, uniform mat

SECTION 757

blended 150 mm into adjacent vegetated areas or previous mulch applications.

757.39 Related Work - Additional related work such as the application of erosion control mats, compost blankets, or other coverings, and harrowing or discing of soil following material application, shall be as specified in the Special Provisions.

757.40 Clean-up - All surplus and waste materials resulting from seeding operations shall be removed from the job site after empty product containers have been inspected by the Ministry Representative.

Hydraulic seeding and/or mulching overspray that may cause problems on areas or objects not designated for re-vegetation, shall be removed in an appropriate manner.

757.41 Conditions for Acceptance -Treated areas will be accepted by the Ministry when the following conditions have been met:

- a) Treated areas are not thin with bare patches, or uneven in distribution.
- b) Empty containers of materials used during the work are stored neatly on Site for inspection by the Ministry Representative.

REVEGETATION SEEDING

757.42 Guarantee & Repairs - The Contractor shall restore disturbed areas beyond the cut slopes at the direction of the Ministry Representative. Seeded areas that show thin application or bare spots shall be re-treated with the specified materials at the earliest opportunity, weather and season permitting. No additional payment will be made for the repairs

MEASUREMENT

757.81 General - Revegetation Seeding shall be measured by the area treated, to the nearest tenth of a hectare [0.1 ha]. The treated areas will be calculated by actual measurement along the slope, and within the right-of-way, or as directed by the Ministry Representative.

PAYMENT

757.91 General - Payment for REVEGETATION SEEDING will be at the Unit Price per hectare bid for "Revegetation Seeding" in Schedule 7, as measured in place. The Contract Unit Price shall be accepted as full compensation for the work described and all work subsidiary and incidental thereto for which separate payment is not elsewhere provided.

MINISTRY OF TRANSPORTATION AND HIGHWAYS

DAILY SEEDING/APPLICATION RECORD

SHEET # _____

PROJECT # _____

DATE	LOAD #	AREA COVERED IN HECTARES			SEED APPLIED* (IN KG.)			OTHER MATERIALS* (IN KG.)			REMARKS
		GRASS	MULCH	REFERT	GRASS	RYE	OTHER	FERT	MULCH	TACK	
	1										
	2										
	3										
	4										
	5										
	6										
	7										
	8										
	9										
	10										
	11										
	12										
	13										
	14										
	15										
	16										
	17										
	18										
	19										
	20										
Total of Sheet											

**Provide details of seed mixes and other materials, as required, in this space:*

THIS SHEET CERTIFIED CORRECT:
 FOR MINISTRY _____
 FOR CONTRACTOR _____
 DATE: _____

TABLE 757. 1: STANDARD GRASS SEED MIXES AND MATERIAL APPLICATION RATES FOR REVEGETATION OF BRITISH COLUMBIA HIGHWAY ROADSIDES

Unless otherwise noted, standard application rates are as follows:

<u>Grass seed Mix</u>	<u>75 kg/ha</u>
<u>Nurse Crop Grass (when specified)</u>	
<u>Fall Rye</u>	<u>50kg/ha</u>
<u>Axcella Annual Rye</u>	<u>25kg/ha</u>
<u>Fertilizer</u>	<u>300 kg/ha</u>
<u>Wood Fibre Mulch</u>	<u>1500 kg/ha</u>
<u>Tackifier</u>	<u>Per Manufacturer's Instructions</u>

CLIMATIC AREA	STANDARD MIXES (by weight)	APPLICATION
South Coast	<u>Vancouver Island / Coast Mix</u> Perennial Ryegrass 26% Creeping Red Fescue 24% Alsike Clover 14% Hard Fescue 13% White Clover 9% Timothy 8% Canada Bluegrass 4% Redtop 2%	General seeding coastal locations where mean annual precipitation is > 90 cm. Fertilizer: 16-32-6, or pre-approved equivalent
	<u>Interior Forestland Mix</u> Intermediate Wheatgrass 32% Alfalfa ("Rambler") 20% Perennial Ryegrass 15% Annual Ryegrass 15% Hard Fescue 10% White Dutch Clover 5% Canada Bluegrass 2% Redtop 1%	General seeding inland where mean annual precipitation is >50 cm. Fertilizer: 16-32-6, or pre-approved equivalent
	<u>Interior Dryland Mix</u> Crested Wheatgrass 40% Tall Wheatgrass 25% Slender Wheatgrass 20% Hard Fescue 15%	General seeding inland where mean annual precipitation is < 30 cm. Fertilizer: 16-32-6, or pre-approved equivalent
Thompson – Okanagan	<u>Interior Forestland Mix</u> Intermediate Wheatgrass 32% Alfalfa ("Rambler") 20% Perennial Ryegrass 15% Annual Ryegrass 15% Hard Fescue 10% White Dutch Clover 5% Canada Bluegrass 2% Redtop 1%	General seeding inland where mean annual precipitation is >50 cm. Fertilizer: 22-11-11, or pre-approved equivalent

CLIMATIC AREA	STANDARD MIXES (by weight)	APPLICATION
	<p><u>Interior Dryland Mix</u> Crested Wheatgrass 40% Tall Wheatgrass 25% Slender Wheatgrass 20% Hard Fescue 15%</p> <p><u>Alkaline Tolerant Blend</u> Crested Wheatgrass 35% Sherman Big Bluegrass 20% Hard Fescue 20% Canada Bluegrass 15%</p>	<p>General seeding inland where mean annual precipitation is < 30 cm. Fertilizer: 22-11-11, or pre-approved equivalent</p> <p>General seeding in alkaline soils. Fertilizer: 22-11-11, or pre-approved equivalent</p>
Kootenays	<p><u>Interior Forestland Mix</u> Intermediate Wheatgrass 32% Alfalfa ("Rambler") 20% Perennial Ryegrass 15% Annual Ryegrass 15% Hard Fescue 10% White Dutch Clover 5% Canada Bluegrass 2% Redtop 1%</p> <p><u>Kootenay Dryland</u> Tall Wheatgrass 45% Crested Wheatgrass 20% Alfalfa ("Rambler") 15% Hard Fescue 7% Sheep Fescue 5% Alsike Clover 5% Canada Bluegrass 2% Redtop 1%</p>	<p>General seeding inland where mean annual precipitation is >50 cm. Fertilizer: 22-11-11, or pre-approved equivalent</p> <p>General seeding inland where mean annual precipitation is < 50 cm. Fertilizer: 22-11-11, or pre-approved equivalent</p>
Northern (Prince George Area)	<p><u>North East General Mix</u> Smooth Bromegrass 40% Creeping Red Fescue 20% Timothy 15% Alfalfa 15% Alsike Clover 10%</p> <p><u>North East Dryland Mix</u> Crested Wheatgrass 35% Intermediate Wheatgrass 25% Alfalfa 15% Smooth Bromegrass 10% Creeping Red Fescue 10% Alsike Clover 5%</p>	<p>General seeding inland where mean annual precipitation is > 50 cm. Fertilizer: 26-16-8, or pre-approved equivalent</p> <p>General seeding inland where mean annual precipitation is < 50 cm. Fertilizer: 26-16-8, or pre-approved equivalent</p>

CLIMATIC AREA	STANDARD MIXES (by weight)	APPLICATION
Northern (Terrace Area)	<u>North West General Mix</u> Smooth Bromegrass 70.6% Alfalfa 18.0% Creeping Red Fescue 3.9% Alsike Clover 3.4% Timothy 2.9% Kentucky Bluegrass 1.1%	General seeding inland where mean annual precipitation is > 50 cm. For use in CWH and ICH biogeoclimatic zone. Fertilizer: 22-11-11, or pre-approved equivalent
	<u>North West Dryland Mix</u> Intermediate Wheatgrass 47.7% Alfalfa 19.1% Crested Wheatgrass 17.9% Orchardgrass 9.1% Hard Fescue 3.0% White Clover 2.1% Kentucky Bluegrass 1.1%	General seeding inland where mean annual precipitation is < 50 cm. For use in SBS biogeoclimatic zone (East of Moricetown to West of Endako) Fertilizer: 22-11-11, or pre-approved equivalent
	<u>Northern Coastal Mix:</u> Alfalfa 46.6% Intermediate Wheatgrass 14.0% Smooth Bromegrass 10.3% Kentucky Bluegrass 9.0% Sheep Fescue 8.2% Birdsfoot Trefoil 6.2% Timothy 5.7%	General seeding coastal locations where mean annual precipitation is > 90 cm. For use in CWH biogeoclimatic zone (QCI, Prince Rupert to Pacific) Fertilizer: 22-11-11, or pre-approved equivalent
	<u>Northern Mix:</u> Hairy Vetch 57.3% Crested Wheatgrass 16.4% Alfalfa 13.1% Creeping Red Fescue 5.3% Orchardgrass 3.8% Birdsfoot Trefoil 3.1% Kentucky Bluegrass 1.1%	General seeding coastal locations where mean annual precipitation is > 90 cm. For use in ICH and BWBS biogeoclimatic zones. (ICH – Pacific to Moricetown, Kitwanga to Thomas Creek 220 km N) (BWBS – Thomas Creek to Yukon border) Fertilizer: 22-11-11, or pre-approved equivalent
	<u>Ditch Vegetation Seed Mixture</u> Crested Wheatgrass 38.7% Alfalfa 30.9% Creeping Meadow Foxtail 15.8% Birdsfoot Trefoil 6.9% Reed Canarygrass 4.8% White Clover 1.6% Kentucky Bluegrass 1.2%	For use in revegetating roadside ditches following ditch maintenance operations. Fertilizer: 22-11-11, or pre-approved equivalent

CLIMATIC AREA	STANDARD MIXES (by weight)	APPLICATION
Vancouver Island	<p>Vancouver Island / Coast Mix</p> <p>Perennial Ryegrass 26%</p> <p>Creeping Red Fescue 24%</p> <p>Alsike Clover 14%</p> <p>Hard Fescue 13%</p> <p>White Clover 9%</p> <p>Timothy 8%</p> <p>Canada Bluegrass 4%</p> <p>Redtop 2%</p>	<p>General seeding coastal locations where mean annual precipitation is > 90 cm.</p> <p>Fertilizer: 18-18-18</p>

MEAN ANNUAL PRECIPITATION

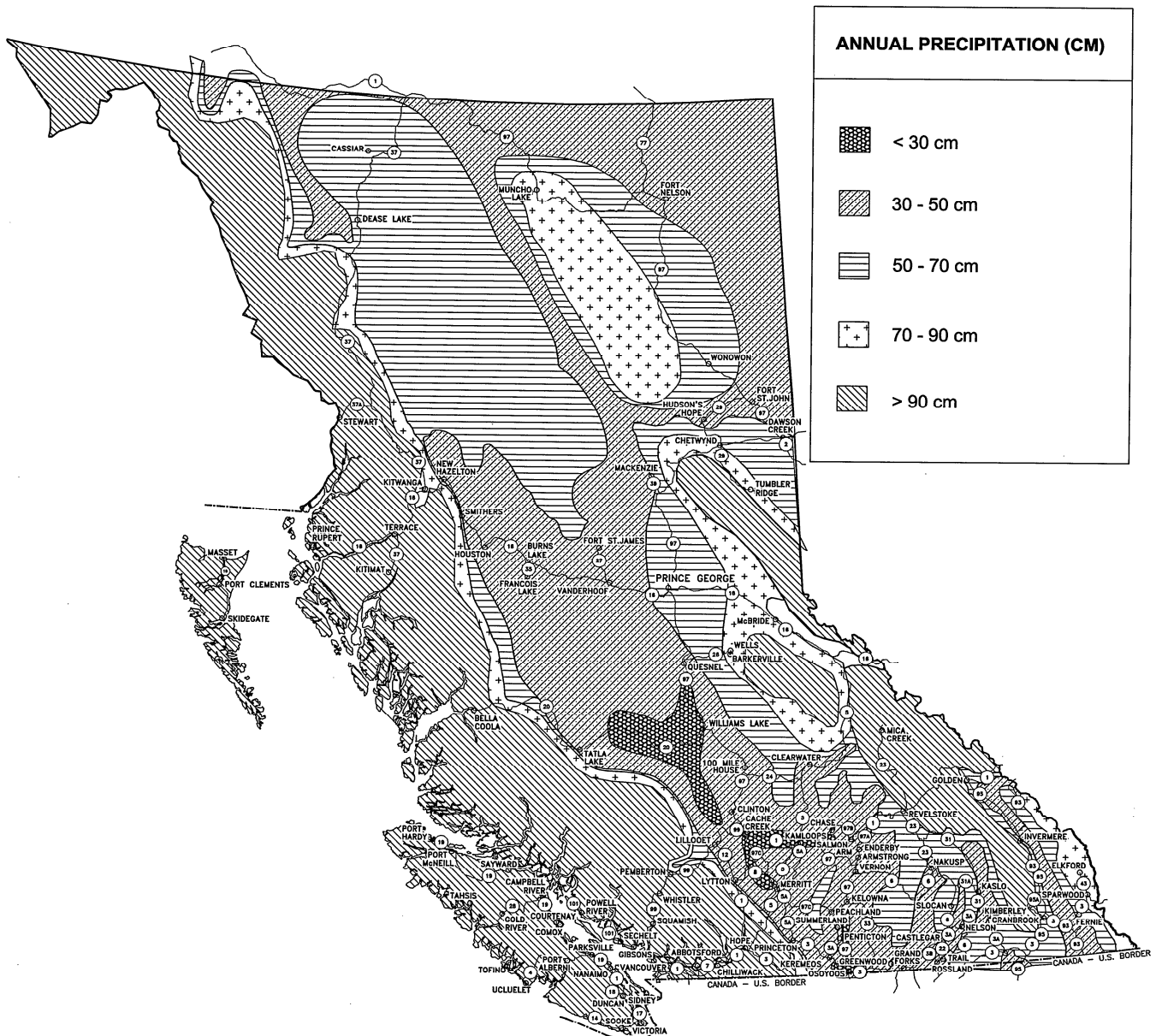

SECTION 766

IRRIGATION

DESCRIPTION

766.01 Scope - The work consists of the supply of all material, labour and equipment to install a complete and operating irrigation system as shown on the Drawings. The Contractor shall be responsible for obtaining all permits required.

766.02 Site Security - The Contractor shall be responsible for maintaining all security at the project Site at all times, and shall ensure that no damage or breakage occurs to stockpiled materials or to the partially installed irrigation system. The Contractor shall make good all damage resulting from acts of vandalism throughout the period of installation and subsequent maintenance.

766.03 Electrical Trades - The Contractor shall contact the Electrical Trades Supervisor prior to performing work on any existing Ministry owned equipment. All AC electrical connections shall be done by a qualified electrician.

766.04 Drawings and Instructions - The Contractor shall install the irrigation system as shown and detailed on the Drawings and Specifications. No deviation from the indicated make and model or installed location of valves, mains, laterals or any other irrigation system component will be allowed without first obtaining written permission from the Ministry Representative.

The Contractor shall maintain a daily record of construction activities. Upon completion of the Contract, the Contractor shall incorporate all accumulated information relevant to the Contract into the required as-built Drawings. The as-built Drawings shall be to the Ministry Representative's satisfaction, shall be reproducible, and shall be compiled by a competent professional draftsman.

The Contractor shall prepare drawings showing the final location and make of all heads, emitter locations, pipe layout and other pertinent information, and shall submit two sets of these Drawings to the Ministry Representative. The Contractor shall prepare another Drawing showing the wiring and automatic controller station numbers with all electrical data. The Contractor shall submit two copies of this Drawing and one set of the operating instructions for the controller, complete with spare parts list to the Ministry Representative. All Drawings, spare parts lists, and operating instructions shall be cerlox bound into a plastic covered 8 1/2 x 11 booklet.

After the system has been completed, the Contractor shall instruct the Ministry Representative's agent in the proper use of the equipment.

Completion will not be certified until adjustments and Drawings are approved.

766.05 References - Codes & Standards - In the absence of other instructions, the provisions of all the following codes and standards shall apply: The National Building Code of Canada; Current CSA Specifications for copper, steel and plastic pipe; AWWA Specification, current editions.

MATERIALS

766.11 General - Shipping, handling and installation of materials shall be to manufacturer's recommended instructions, and best work practice. Particular care shall be taken to avoid scratches and nicks on the plastic pipe. Pipe must be properly stacked and stored in a clean place on the Site, keeping dirt out of the pipe at all times.

766.12 Pipes and Fittings - Galvanized pipe, Schedule 40, with galvanized fittings, shall be used inside culverts. The pipe shall be connected to the plastic main or lateral 450 mm clear of the culvert.

Plastic pipe shall be used for the submain and laterals of the irrigation system. Plastic pipe shall be semi-rigid extruded from PVC (Polyvinyl Chloride) resin, Type 1, grade 2, normal impact.

The minimum classes to be used are listed in Table 766-A.

TABLE 766-A MINIMUM CLASSES OF PLASTIC PIPE

Up to 25 mm diameter	Class 200 for excavated trenches
30 mm diameter and larger	Class 160 for excavated trenches
All sizes	Class 200 for pipe flow

Fittings shall be PVC plastic, Schedule 40 or 80, designed for solvent welding to PVC pipe.

All fittings must have 1/2 to 2/3 interface fit to ensure a fully seated joint. Individual fittings shall be selected to ensure a proper fit or they will be rejected.

All pipe and fittings shall be continuously and legibly marked with at least the following information:

- Manufacturer's name or trademark;
- Pressure rating;
- Type of material.

Pipe that is not marked to the satisfaction of the Ministry Representative will be rejected and shall be removed from the Site by the Contractor.

766.13 Cement - Pipe cement for solvent welding shall be of the type and make recommended by the pipe manufacturer, supplied to the Site in sealed containers

SECTION 766

clearly marked with the name of the manufacturer and the lot number. The Contractor shall comply with the manufacturer's instructions and safety procedures.

766.14 Sprinkler Heads - Risers for turf heads, lawn heads, impact heads, shrub heads and quick-coupling (QC) valves shall be swing joint type, fabricated from Schedule 80 PVC or Schedule 40 galvanised pipe and fittings, as detailed in the Specifications. Teflon tape shall be used on all threaded connections.

Sprinkler heads shall be as detailed on the Drawings.

766.15 Valves - Automatic valves shall be as detailed on the Drawings and the same make shall be used throughout. Automatic valves shall have flow control stems.

Valves shall be installed in Carson Industries No. 1419 valve boxes or other approved alternative complete with extensions and covers, as required. The top of all valve box covers shall be flush with the finished grade.

766.16 Controllers - Automatic controllers shall be supplied to operate the electrically controlled automatic valves. Controllers shall be 24 volt A.C. outlet, Class 2 rating, compatible with the valves used. Controllers and automatic valves shall be by the same manufacturer, unless otherwise noted. Controllers and transformers must bear CSA or Provincial stamps of approval. Controllers shall be as detailed on the Drawings.

Controllers shall be installed in Ministry standard controller box 30-A-120/240V, weatherproof, stainless steel service panel SN1765A as shown on Drawing SP635-2.4.8, or pre-approved equal complete with a Masterlock No. 15 padlock and two sets of keys for the lock.

766.17 Wiring - Wire between controllers and automatic valves shall be of a type approved for direct burial. Where control wires are exposed or pass through culverts, they shall be installed in rigid electrical conduit.

Wire shall be minimum 14 gauge single strand T.W.U.

766.18 Selected Native Fill - Native fill selected for backfilling shall be free of stones, gravel, wood or any other debris, and shall be approved by the Ministry Representative.

CONSTRUCTION

766.31 General - Damaged Material - Damaged material shall be rejected on the decision of the Ministry Representative. The Contractor shall take care to prevent dirt from entering the pipe.

Plastic pipe shall not be repaired by patching. Where pipe has been damaged, the damaged section shall be removed and a new section shall be installed complete with new fittings.

766.32 Line Location - The Contractor shall ensure that all irrigation pre-ducts for passage of irrigation lines under roadways, medians, traffic islands and other surface impediments have been installed and are clearly marked at

IRRIGATION

all entry points.

No irrigation line shall be installed parallel to and directly over another irrigation line or line of another trade. Lines laid in the same trench shall be a minimum of 50 mm apart. No pipe shall be installed closer than 300 mm to any parallel electric conduit as shown on Drawing SP635-1.5.2.

766.33 Compaction - Before laying the pipe, the Contractor shall be satisfied as to the extent of compaction in the lawn and planting areas.

766.34 Excavation - Excavated soil shall be carefully placed adjacent to the trench for convenient backfilling. Topsoil and subsoil shall be piled separately to avoid contamination of the topsoil.

Stones or other objects larger than 75 mm at their widest point shall be removed from the trenches. Holes below grade lines, caused by the removal of stones, must be filled in and compacted uniformly with the adjacent trench.

766.35 Laying the Pipe - Pipe shall be laid by trench excavation or by an approved vibrating pipe plough. Plastic pipe shall be laid on sand or selected native fill to a compacted depth of 50 mm. A further 75 mm of sand or selected native fill shall be placed over plastic pipes prior to backfilling. Pipes shall be run in straight lines between fittings. Pipe must not be supported at intermediate points on stones, bricks or other hard material.

All mains and laterals shall have a minimum cover of 400 mm of soil as measured from the top of the pipe to the finished grade.

Lawn and planting areas shall be disturbed as little as possible.

The Contractor shall manicure the finished grade over all mains and laterals upon completion of the pipe installation. All debris, rocks over 50 mm diameter, etc, that have been brought to the grade surface shall be removed to the Contractor's own tip. The area over all trenches shall be fine graded and shall conform to SS 751.34.

766.36 Connections - The Contractor shall make connection to the existing water supply where shown on the Drawings. The Contractor shall ensure that the recommended operating pressure of the irrigation system is not exceeded by the water pressure at the source, by installing pressure regulators as required.

766.37 Inspection and Testing - After the pipe is in place in the bottom of the trench with risers in place, the risers shall be capped where the sprinklers will be attached and all pipe fittings exposed. The maximum pressure shall be applied to the system and maintained for a minimum of one hour.

All fittings shall be visually inspected and any that leak shall be cut out and replaced. Leaks shall not be repaired by patching. The test pressure shall be maintained for one hour after replacing any defective sections. The section shall be re-inspected as before.

The system shall be flushed out to remove dirt and then the sprinklers shall be attached using Teflon tape or pre-approved non-setting pipe thread compound.

766.38 Backfill - After approval by the Ministry Representative, the trenches shall be backfilled, maintaining pressure in the line. If there is any indication of a leak, the defective section shall be located and replaced.

The trenches shall be carefully backfilled with the subsoil, followed by the topsoil. Both shall be compacted to the same density as the soil in the trench walls to minimize differential settlement. Backfill around turf heads with 0.03 m³ of sand.

766.39 Controller Installation - The location of the controllers shall be determined on Site in the areas indicated on the Drawings. The Contractor shall have a qualified electrician connect the controllers to the electrical supply.

766.40 Adjustments - The sprinkler system shall be adjusted section by section to give satisfactory coverage to all areas. Pressure at the heads and/or Q.C. valves shall be as noted on the Drawings. Turf heads, lawn heads and Q.C. valves shall be set flush with the final turf grade by adjusting the swing joint riser, as required. During the landscape maintenance/guarantee period, the Contractor will return twice and adjust the heads, as required, to be flush with the final turf grade.

These callbacks shall be done within five days of notification by the Ministry Representative and shall be considered part of the Contract requirements.

766.41 Surplus Material - Surplus material shall be removed from the Site.

766.42 Conditions for Acceptance - Completion will not be certified until adjustments are completed and as-built Drawings prepared, approved, and bound into an approved booklet to the Ministry Representative's satisfaction. A copy of the inspection certificate issued by the Ministry of Competition, Science and Enterprise indicating compliance with the Electrical Code and a copy of the "Irrigation Systems Loss Calculation Sheet" found in the Ministry of Transportation Landscape Policy - Appendix 3 shall be included in the hardcover booklet.

766.43 General - The Contractor shall monitor the operation of the system and carry out all minor repairs and required adjustments to the spray coverage of irrigation heads and operating times.

The irrigation system shall be properly winterized at the appropriate time of the season.

PAYMENT

766.91 General - Payment for the supply and installation of the irrigation system will be at the lump sum bid. The lump sum price bid shall be full compensation for all labour and equipment required for the specified preparation, trenching, installation, testing, backfilling, clean-up, preparation of as-built Drawings, and instruction in the proper use of the equipment and for all incidental work not required to be separately paid for.

SWING JOINT DETAIL – IMPACT HEAD

SP766-01

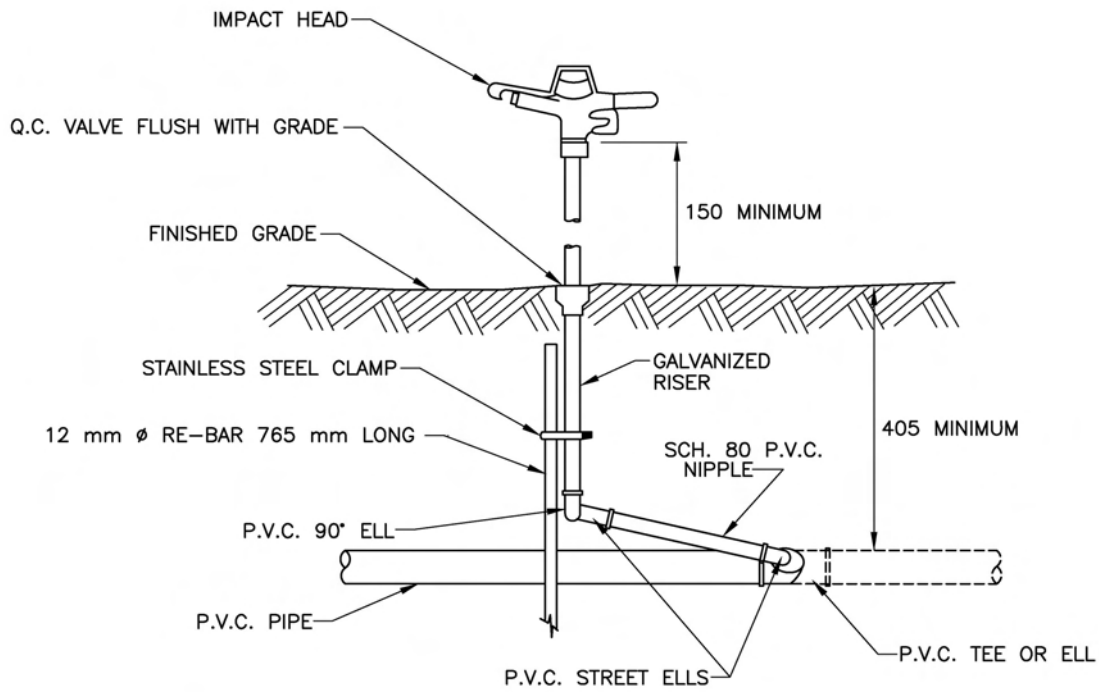

ELEVATION

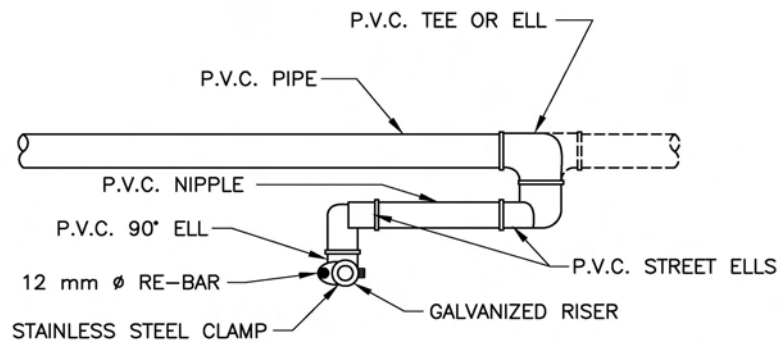

PLAN

SHOWN FOR IMPACT HEAD
QUICK-COUPLING VALVE SIMILAR

NOTE:
USE TEFLON TAPE ON ALL THREADED CONNECTIONS

NOT TO SCALE

ALL DIMENSIONS ARE IN MILLIMETRES UNLESS OTHERWISE NOTED

SWING JOINT DETAIL – TURF HEAD

SP766-02

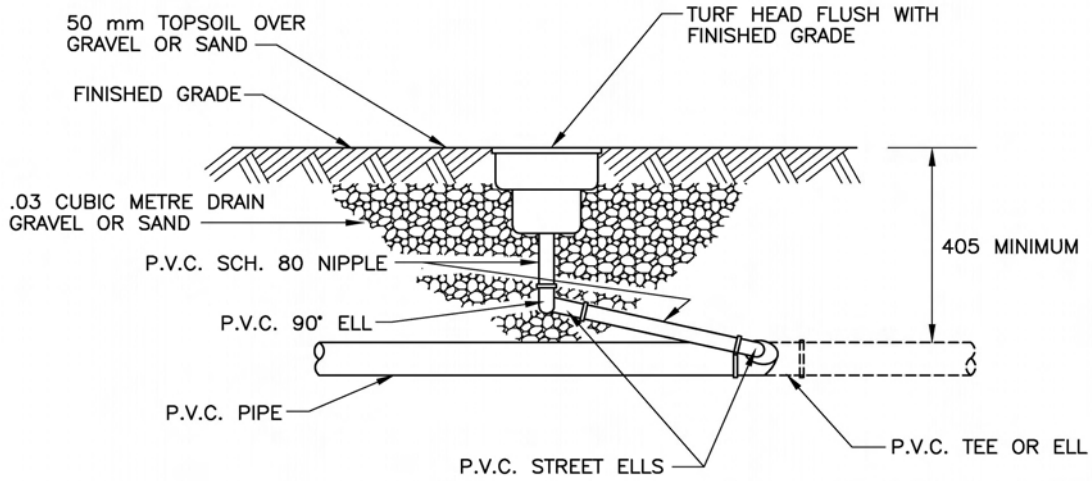

ELEVATION

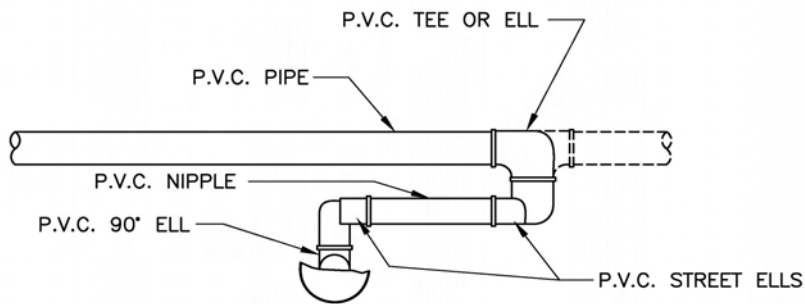

PLAN

SHOWN FOR TURF HEAD
LAWN HEAD SIMILAR

NOTE:
USE TEFLON TAPE ON ALL THREADED CONNECTIONS

NOT TO SCALE

ALL DIMENSIONS ARE IN MILLIMETRES UNLESS OTHERWISE NOTED

THIS PAGE IS LEFT INTENTIONALLY BLANK

SECTION 769

PROTECTION AND RETENTION OF VEGETATION

DESCRIPTION

769.01 Scope - This Section refers to the protective measures required to safeguard vegetation from construction operations, equipment and vehicles, where vegetation is not designated for removal under the Contract, and covers the installation of barriers.

769.02 Related Work - SS 165, Protection of the Environment; SS 200, Clearing and Grubbing; SS 201, Roadway and Drainage Excavation; SS 751, Topsoil and Landscape Grading.

769.03 Definitions

Specimen Trees - means trees so designated in the Contract Documents.

Native Vegetation - means areas of existing and/or indigenous shrubs, trees and groundcover.

Dripline - means the location on the ground surface directly beneath a theoretical line described by the tips of the outermost branches of trees.

Barrier - means fence consisting of approved material, supported by steel posts and being a minimum of 2.0 m high, without breaks or unsupported sections.

MATERIALS

769.11 Water - Water shall be free of impurities that would inhibit germination and growth or may be harmful to the environment.

The Contractor shall supply the water.

769.12 Fertilizer - Fertilizer shall be supplied to the specifications of the Special Provisions and to SS 751.18.

CONSTRUCTION

769.31 Operational Constraints - The Contractor's operations shall not damage vegetation designated for retention.

Existing vegetation shown on the Drawings or designated by the Ministry Representative to be retained shall be marked by the Contractor and inspected by the Ministry Representative, who may adjust the limits. A minimum of 48 hours notice shall be given to the Ministry Representative for this purpose.

Areas shown on the Drawings adjacent to streams or as designated by the Ministry Representative as "Vegetation to remain" areas are not to be disturbed, cleared or logged.

The Contractor's operations shall not cause flooding, sediment deposits or deposition of debris in "Vegetation to Remain" areas.

Where construction procedures substantially alter natural drainage patterns, interim drainage or irrigation shall be

provided as necessary to compensate for construction interference.

Construction procedures, stockpiling of materials or debris burning or disposal shall not be undertaken adjacent to designated trees and/or native vegetation retained.

Unless the Contract requires work within the dripline of trees designated to remain, equipment shall not be operated within that dripline. When the Contract requires work within the dripline of trees designated to remain, operation of equipment within that dripline area shall be kept to the minimum necessary to perform the work required, as required by the Ministry Representative. Tree roots shall be protected from compaction by temporary placement of hogfuel or other lightweight insulative material, as required by the Ministry Representative.

Equipment or vehicles shall not be parked, repaired or refuelled, construction materials shall not be stored and earth materials shall not be stockpiled within the dripline area of any tree designated to remain.

769.32 Clearing and Grubbing - No clearing and grubbing shall be conducted for a radius of 3 m from the trunks which lie on the edge of clearing and grubbing zones, or as directed by the Ministry Representative.

Trees to be removed shall be felled toward the centre of an area, away from selectively cleared or retained vegetation.

Where Drawings or Special Provisions call for areas of "Close Cut No Grubbing", existing trees within the removal zones shall be carefully and cleanly cut as close to the ground as possible, with the understory vegetation retained, and the root zone protected from excessive disturbance.

769.33 Barriers for Existing Vegetation Protection - Barriers for vegetation protection shall be erected prior to commencement of construction operations, at locations specified in the Drawings, to provide a continuous barricade between vegetation and the area of work. The barriers shall be maintained erect and in good repair throughout the duration of construction operations, and shall be removed upon completion of the work, and disposed of outside the project by the Contractor.

The barrier shall be placed at the dripline of trees or forest edges unless this is inadequate space to provide a 1.5 m buffer zone between the barrier and the limit of grading. The barrier shall be placed within the dripline if necessary to provide a buffer zone of up to 1.5 m. Under no circumstance shall it be placed less than 0.75 m from the circumference of the trunk. When the trunks of trees are less than 4.5 m apart, the trees shall be considered a group, and the barrier shall be placed to form a continuous barricade as specified in the Drawings.

SECTION 769

A barrier is not required where an existing fence will serve the same purpose. At such locations, the barrier shall terminate at the existing fence so that a continuous barricade is provided between the trees and the area of work.

769.34 Pruning and Repair of Specimen Trees - Specimen trees and trees safeguarded by barriers shall be repaired in accordance with this Subsection.

One third of the tree branches shall be selectively removed to reduce transpiration and compensate for dieback of roots in fill conditions and damage to the root system in cut conditions.

Within five calendar days of damage, branches 25 mm or greater in diameter that are broken as a result of the Contractor's operations shall be cut back cleanly at the break, or to within 10 mm of their base, if a substantial portion of the branch is damaged.

Roots 25 mm or larger in diameter that are exposed by the Contractor's operations, shall be cut back cleanly to the soil surface within five calendar days of exposure.

Bark that is damaged by the Contractor's operations shall be neatly trimmed back to uninjured bark, without causing further injury, within five calendar days of damage.

PROTECTION AND RETENTION OF VEGETATION

MAINTENANCE

769.71 Watering - The retained specimen trees shall be watered three times during the summer or as stated in the Special Provisions or as directed by the Ministry Representative. The area immediately below the tree crown shall be soaked sufficiently to reach the feeder roots.

769.72 Fertilizing - Where specified or directed by the Ministry Representative, fertilizer shall be applied at a rate of 50 g/mm of caliper to existing specimen trees to be retained. The caliper measurement shall be taken 0.3 m above the grade. The fertilizer shall be applied once early in the growing season unless specified otherwise.

MEASUREMENT

769.81 General - Measurement for barriers will be made in metres according to the length of barrier installed to protect vegetation.

PAYMENT

769.91 General - Payment at the unit price bid for barriers shall be full compensation for work described and all work subsidiary and incidental thereto for which separate payment is not elsewhere provided. Compensation for all costs other than installation of barriers associated with the work of protecting vegetation to be retained shall be deemed to be included in the contract prices for the various tender items of the contract.

SECTION 903

TIMBER - MATERIALS

903.01 General - All timber shall be graded in accordance with the current Standard Grading Rules of the National Lumber Grades Authority. Timber must be grade stamped with the exception of unfinished or rough timber, which may prove too difficult to stamp, in which case a grading certificate may be requested at the option of the Ministry Representative.

903.02 Species and Grade - Timber species and Grade shall be as specified for end use.

“Coastal” Douglas Fir shall be used when Douglas Fir products are specified to receive preservative treatment.

903.03 Inspection - All timber may be inspected before shipment to the construction site, or at the construction

site, or both. The Supplier or Contractor shall provide the necessary facilities to enable the Ministry Representative or the Ministry Representative's authorized alternate to expeditiously examine as many pieces as are deemed necessary. All material rejected shall be replaced at the Supplier's or Contractor's expense including shipping charges and removal of rejected material at the construction site, if applicable. Inspection of timber before shipment shall not be a bar to its subsequent rejection at the construction site if found to fail any requirements of this specification.

No material shall be shipped prior to inspection or until a release for shipment has been issued by the Ministry Representative.

THIS SECTION IS LEFT INTENTIONALLY BLANK

SECTION 904

TIMBER (TREATED AND UNTREATED) - FABRICATION AND HANDLING

904.01 General - All timber shall conform to the requirements of SS 903, Timber - Materials. Timber to be treated shall be treated in accordance with SS 908, Preservative Treatment - Wood Products. Except as modified herein, preservative treated wood products shall be handled in accordance with the most recent edition of CSA Standard O80, Wood Preservation.

904.02 Framing - All the cutting, boring, framing, match marking, etc. required on all timber shall be done by competent bridge framers in a thorough manner, in accordance with good work practice. It shall be done such that surfaces in contact shall bear evenly and fully; no shims or open joints are permitted. All measurements shall be accurate. Gains and daps shall have plane, smooth surfaces.

904.03 - Not Used.

904.04 Handling of Untreated Timber - All materials shall be handled with reasonable care. Timber shall not be bashed, bruised, gouged, cracked, split or otherwise damaged. Minor damage, in the opinion of the Ministry Representative, shall be repaired at the Contractor's expense; severely damaged materials will be rejected and replaced entirely at the Contractor's expense including all shipping and disposal charges.

904.05 Preparation of Timber Before Treatment - All timber shall be dried sufficiently prior to treatment to ensure proper penetration of preservative during the treatment process and to prevent checking after treatment.

All cutting, such as boring, chamfering, framing, gaining, surfacing, trimming etc., shall be done prior to treatment.

In the event that cutting becomes absolutely necessary after treatment, the cut surfaces shall be saturated with preservative according to Section 9.1.4 of CSA Standard O80, Wood Preservation.

904.06 Condition After Treatment - After treatment, timber with checks exceeding the limiting sizes in the NLGA Standard Grading Rules for the grade specified on the purchase order, Work Order, Special Provisions or Drawings shall be rejected.

904.07 Handling of Treated Timber - Pointed tools or equipment such as dogs, hooks, peavies, etc. shall not be used on the side surfaces of treated timber. The use of pointed tools shall be confined to the end grain and shall be such as to avoid damage to the pressure-treated surface.

Treated timber shall not be dragged along any surface.

Any damage done shall be repaired or replaced to the satisfaction of the Ministry Representative.

THIS PAGE IS LEFT INTENTIONALLY BLANK

SECTION 905

TIMBER - GLUED LAMINATED

905.01 General - The requirements of the current CSA Standard O122 - Structural Glued Laminated Timber shall apply to all glued laminated members. Wood species shall be as specified, except that if the members are to be pressure treated in accordance with the latest version of CSA Standard O80 (See SS 908) they may only be of Coast Region Douglas Fir or Western Hemlock.

905.02 Classification - Unless otherwise specified, the appearance grade shall be Industrial and the service grade shall be Exterior. The stress grade shall be as shown on the drawings, purchase order or work order.

905.03 Quality Control - Laminations shall be grade-marked and the marking shall be visible until the glue has been applied.

The shear tests described in Appendices "A" and "B" of CSA Standard O122 shall be carried out by the Contractor. Copies of the shear test results shall be forwarded to the Ministry Representative.

Vacuum-pressure cycle tests may be carried out as directed by the Ministry, and the Contractor shall supply the Ministry with a full section cut-off, 75 mm long, from each end of the member for this purpose.

905.04 Incising - All surfaces of members shall be incised prior to pressure treatment.

905.05 Handling of Treated Glued Laminated Members - Members shall be protected to avoid damage due to handling: dogs, hooks, peavies or other equipment shall not be used on the side surfaces of treated timber. All handling of treated timber with pointed tools shall be confined to end grain and shall be such as to avoid damage to the original pressure-treated surface.

Subject to the approval of the Ministry Representative, the Contractor shall make good superficial damage of treated timber by the methods outlined in the current edition of CSA Standard O80 - Wood Preservation. Timber which, in the opinion of the Ministry Representative, cannot be made good by such methods will be rejected.

905.06 Storage of Glued Laminated Members - Members lying in storage shall be supported evenly on a flat surface. When stored for a prolonged time, they shall be gapped to permit air circulation and covered to prevent UV damage.

905.07 Inspection - All timber and all phases of the work including pressure treatment, if applicable, may be inspected by the Ministry Representative or the Ministry Representative's authorized alternate. The Ministry shall be given 48 hours notice of commencement of gluing and pressure treating, if applicable. The Contractor shall provide the necessary facilities to enable the Ministry Representative or the Ministry Representative's authorized alternate to expeditiously examine as many pieces as are deemed necessary by the Ministry Representative. All material rejected shall be replaced at the Contractor's expense including shipping charges and removal of rejected material at the construction site, if applicable. Inspection of glued laminated timber before shipment shall not be a bar to its subsequent rejection at the construction site if found to fail any requirements of the Specification.

No material shall be shipped prior to inspection or before a release for shipment has been issued by the Ministry Representative

THIS PAGE IS LEFT INTENTIONALLY BLANK

SECTION 906

ROUND TIMBER PILES

906.01 Scope - This Section covers the quality and manufacture of untreated and pressure-treated round timber piles.

Where convenient, the requirements contained in this Section use the wording of the current CSA Standard CAN3-Q56-M "Round Wood Piles", in particular for term definition (see Appendix A) and the majority of measurement and material requirements.

Preservative treatment of piles shall conform to the requirements of SS 908, Preservative Treatment - Wood Products.

906.02 Species

906.02.01 Untreated Piles - This specification does not restrict the species used for untreated piles except as may be specified for end use.

906.02.02 Pressure Treated Piles - Species of piles to be pressure treated shall be as specified and restricted to those for which pressure treating specifications are included in CSA Standard Q80, Wood Preservation. Pressure treatment of piles shall be according to SS 908.

906.03 Size - The size of a pile shall be designated by length and either minimum and maximum butt diameter or minimum and maximum tip diameter, or both. Sizes of piles normally available are shown in Table 906-A.

TABLE 906-A SIZES OF TIMBER PILES

Size Designation	36	33	30	27	24
Minimum Diameter at Extreme Butt or Large End (mm)	360	330	300	270	240
Length in Metres	Minimum Diameter at Small End Tip (mm)				
Up to 6	250	250	230	200	180
6 to 11	250	230	200	180	150
12 to 14	230	200	180	150	-
15 to 18	200	180	180	-	-
19 to 21	200	180	150	-	-
22 to 27	180	150	-	-	-
28 to 32	150	130	-	-	-

906.04 Diameter

a) All measurements of diameter shall be made inside the bark.

b) The diameter of treated piles shall be measured after treatment.

c) Butt diameters shall be measured at the extreme butt.

d) Tip diameters shall be measured at the extreme tip.

e) The diameter of a pile shall be determined either by measuring the circumference in millimetres and dividing the result by 3.14 or by taking the average of the maximum and minimum diameter.

f) A variation of -15 mm in the diameter at the tip or at the butt but not in both, shall be allowed in not more than 25% of the piles when the specification of four or more piles is to be determined.

g) If allowances are specified, they shall supersede SS 906.04 (f).

906.05 Length

a) Pile lengths shall be measured in metres.

b) A variation of ± 150 mm from designated lengths will be permitted, unless allowable over and under lengths are specified.

906.06 General Material Requirements - Piles shall be cut from sound live trees. Sides and end surfaces of the piles shall be free of ice, snow and mud, and exposed for visual inspection.

Untreated piles shall be sound and close-grained.

Treated piles shall:

- have not less than 25 mm sapwood, and shall be cleanly peeled;
- not be cored until 24 hours after treatment;
- be cored in the middle third of the length of the pile.

906.07 Prohibited Defects

- Through checks
- Bird holes
- Cross-breaks of grain (cracks)
- Decay
- Nails, spikes and other metal or foreign substance
- Holes in treated piles (except holes for test purposes, which shall be properly plugged). Holes for brailing purposes shall be drilled prior to treatment
- Shakes in the tip
- Splits in the tip
- Insect damage
- Any abnormal change in cross-section (including ground swell)
- Knot clusters

- Unsound scars (cat faces)
- Short crooks (see Drawing SP906-01)
- Reverse sweep (see Drawing SP906-02)
- Burst - unsound piling which have 15 mm or more of a concentration of oil in the deadwood

906.08 Permitted Defects

- Firm red heart
- Hard stain
- Compression wood

906.09 Limited Defects

a) Checks caused by treating and normal seasoning shall not exceed the following:

- i) Checks in the tips of the pile from the pith to the circumference shall not be wider than 10 mm at the circumference.
- ii) If checks are wider than 10 mm but not deeper than 1/3 of the diameter of the pile, not more than three of these checks shall occur in the circumference of the pile at that point. If checks are deeper than 1/3 of the diameter of the pile but not to the heart, and not wider than 10 mm, then only two such checks shall occur in the circumference of the pile at that point. The sum of all the widths of checks in a pile shall not exceed 1/4 of the diameter where they occur.

b) Sound Knots will be permitted as follows:

- i) For piles 15 m and less in length, knots up to 100 mm in diameter will be permitted provided that the sum of all knot diameters does not exceed 1/3 of the diameter of the pile at the section where they occur;
- ii) For piles more than 15 m in length, knots between:
 - mid-length and butt shall conform to the requirements for piles of 15 m or less;
 - mid-length and the tip, up to 120 mm in diameter, will be permitted provided that the sum of all knots does not exceed 1/2 of the diameter of the pile at the cross-section where they occur.

c) Shakes in the butt end of a pile are permitted provided that they are not closer than 50 mm to the surface of the pile and the length of any single shake, or the total length of any number of shakes measured along the line of the shake does not exceed 1/3 of the measured diameter of the butt.

d) Splits in the butt end of a pile are permitted provided that they are not longer than the diameter of the butt.

e) Sweep is permitted provided that it cannot be classified as short crook or reverse sweep and provided that:

- i) For piles less than 20 m in length, a straight line joining the mid-point of the butt and the mid-point of the tip does not at any intermediate point pass outside the surface of the pile;
- ii) for piles 20 m and up to 24 m in length, a similar straight line does not lie more than 30 mm outside the surface of the pile; or
- iii) for piles over 24 m in length, a similar line does not lie more than 60 mm outside the surface of the pile.

Note: See Drawing SP906-01

f) Holes for untreated piles less than 10 mm in average diameter will be permitted provided that:

- i) they are scattered over the surface of the pile; and
- ii) the sum of the average diameter of all holes in any square 300 mm x 300 mm of pile surface does not exceed 40 mm and the depth of any one hole does not exceed 40 mm.

g) Spiral Grain shall not exceed 1/2 turn in any 6 m length of pile.

906.10 Manufacturing Requirements - All piles shall be cut above the ground swell and have a uniform taper throughout their whole length.

Completely overgrown knots rising more than 30 mm above the pile surface, branch stubs, and partially overgrown knots shall be trimmed close.

Peeling of piles by hand or machine shall be done carefully so as not to gouge or otherwise damage the surface of the pile, and the reduction in thickness of sapwood shall be the minimum possible.

Sawing of butts and tips shall be cut perpendicular to the axis of the pile. Bevelling at the ends of the piles shall not be permitted.

906.11 Storage - Piles shall be stacked in treated or other non-decaying skids of such dimensions, and so arranged as to support the piles without producing noticeable distortion of any of them. A cover should be put over them to protect against the elements.

906.12 Handling - Handling damage will be unacceptable if it reduces the depth of sapwood so as to render the pile untreatable.

- a) All piles shall be handled with reasonable care. Piles shall not be bruised or otherwise damaged. Minor damage shall be repaired and severely damaged piles shall be replaced as per SS 906.12 (d).
- b) During lifting, long piles shall be supported at a

sufficient number of properly located points to prevent damage due to excessive bending.

c) Dogs, hooks, peavies or other equipment shall not be used on the round surface of treated piling, except in the last one metre of the butt end.

d) The Contractor shall make good any superficial damage of treated piles by methods outlined in the current edition of CSA Q80 "Specification of Wood Preservation". Piles, which, in the opinion of the Ministry Representative, cannot be made good by such methods, will be rejected.

906.13 Inspection - All piles may be inspected before shipment to the construction Site, at the construction Site or both. The Supplier shall provide the necessary facilities to enable the Ministry Representative or authorized Inspector to expeditiously examine all parts of each pile. All piles rejected shall be replaced at the Supplier's expense, including shipping charges and removal of reject piles from the construction Site, if applicable. Inspection of the piles before shipment shall not be a bar to their subsequent rejection at the construction Site if found to fail any requirements of this Section.

Inspection of any preservative treatment shall be in accordance with SS 908.03.

Treated piles being supplied from previously treated stock shall have been clearly stamped with the applicable Charge Number or other positive identification, and the appropriate treatment records shall be made available to the Ministry Representative for inspection. All piles being supplied from previously treated stock shall be subject to re-inspection which shall be in accordance with SS 908.03.

Piles to be supplied from previously treated stock which have been stored in water shall, if ordered by the Ministry Representative, be removed from the water if such action is required to provide adequate inspection. At the Supplier's option, such inspection may be carried out at the construction Site. All piles rejected at the construction site shall be removed and replaced at the Supplier's expense.

906 APPENDIX A - Definitions

Check: separation of the wood along the grain, the greater part of which occurs across the rings of annual growth.

Through check: a check, which extends from surface to surface of the pile, usually through the pith centre.

Compression wood: wood which has grown abnormally as often occurs on the lower side of branches and inclined trunks of coniferous trees.

Compression wood:

- is denser and harder than normal wood but may be lower in strength for its mass.
- is characterized by relatively wide annual rings, usually

eccentric.

- has a relatively high proportion of summerwood (frequently more than 50% of the width of the annual rings in which it occurs).
- exhibits little contrast in colour between springwood and summerwood, and
- shrinks excessively lengthwise as compared with normal wood.

Crack: separation of the wood cells across the grain (this may be due to internal strains resulting from unequal longitudinal shrinkage or to external forces).

Decay (rot, dote): the disintegration of the wood substance, due to the action of wood-destroying fungi (rot and dote mean the same as decay).

Grain: the direction, size, arrangement, and appearance of fibres in a pile.

Spiral grain: a type of growth in which the fibres take a spiral course about the bole of a tree instead of the normal vertical course. The spiral may extend right-handed or left-handed around the tree trunk. The amount of spiral grain in a pile is measured as the distance in metres, along the axis of the pile in which one complete twist of the spiral occurs, and is expressed as, for example, 1 turn in 12 m.

Hole: an opening, perforation or cavity in a pile.

Bird holes: holes and damage caused by woodpeckers and other species of birds.

Plugged holes: holes that have been filled by forcing in another piece of wood.

Insect damage: result of boring in the pile by insects or insect larvae. Scoring or channelling of the surface is not classified as insect damage.

Knot: that portion of a branch or limb that has become incorporated into the body of a tree.

Knot cluster: two or more knots grouped together as a unit with the fibres of wood deflected around the entire unit.

Knot diameter: the diameter of a knot as it appears on the surface of a pile measured in a direction at right angles to the lengthwise axis of the pile.

Unpeeled: no attempt is made to remove the bark from the pile, but does not mean that all of the bark is on the pile as it may be scuffed, knocked, or worn off after the pile is cut.

Rough peeled: all of the outer bark is removed from the pile.

Clean peeled: all of the rough bark is removed from the pile, and all of the inner bark from at least 80% of the

SECTION 906

ROUND TIMBER PILES

surface of the pile, no piece of inner bark more than 200 mm long remains on the surface of the pile, and there is at least 30 mm of clean wood surface between any two strips of inner bark.

Red heart: a condition caused by fungus (*Fomes pini*, *Trametes pini*) which occurs in the living trees of some conifers. It is characterized in the early stages of infection by a reddish or brownish colour in the heartwood. Later the wood in the living tree disintegrates (decays) in small, usually distinct areas that develop into white-lined pockets.

Firm red heart: the early stages of infection, characterized by a reddish or brownish colour in the heartwood, which does not affect the strength of the pile.

Scar (cat face): a depression in the surface of the pile resulting from a wound where healing has not re-established the normal cross-section of the pile.

Shake: a separation along the grain, the greater part of which occurs between the rings of annual growth.

Short crook: a localized deviation from straightness

which, within any section 2 m or less in length, is more than 70 mm (see Drawing SP906-01).

Sound: free from decay and insect holes.

Split: a lengthwise separation of the wood due to the tearing apart of the wood cells which usually extends from surface to surface of the pile.

Stain: a discolouration on or in the wood other than its natural colour, caused by the action of certain moulds and fungi.

Hard stain: a stain, which is not accompanied by softening or other disintegration of the wood.

Sweep: the deviation of the pile from straightness (see Drawing SP906-01).

Reverse sweep: a deviation from straightness, which changes direction or reverses direction in the length of the pile (see Drawing SP906-02).

MEASUREMENT OF SWEEP AND CROOK IN PILES

SP906-01

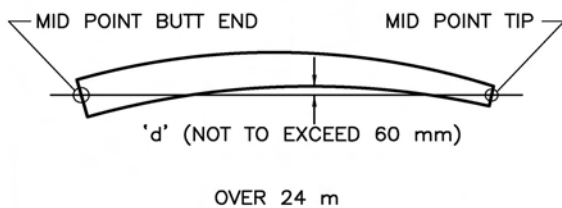
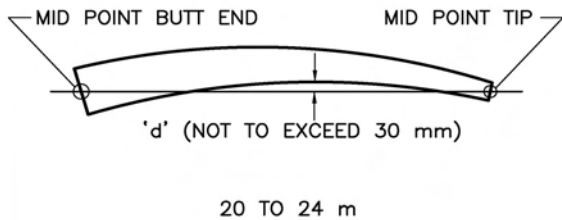
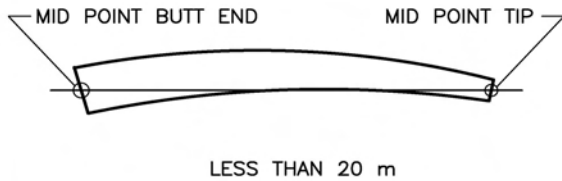

MEASUREMENT OF SWEEP

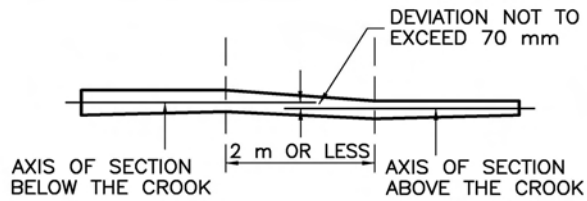

CASE 1: WHERE THE REFERENCE AXES ARE APPROXIMATELY PARALLEL.

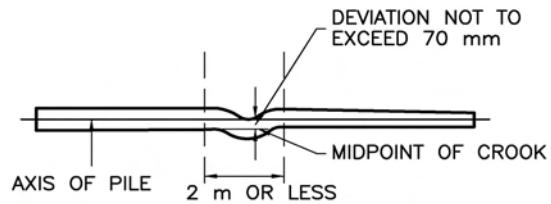

CASE 2: WHERE AXES OF SECTIONS ABOVE AND BELOW THE CROOK COINCIDE OR ARE PRACTICALLY COINCIDENT.

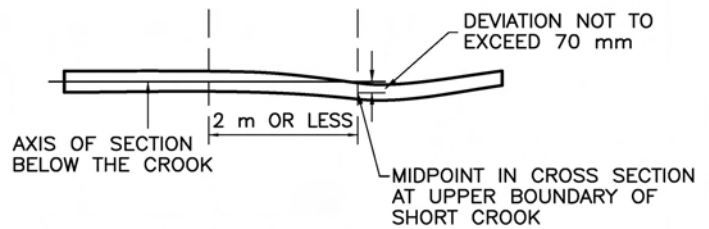

CASE 3: WHERE AXIS OF SECTION ABOVE SHORT CROOK IS NOT PARALLEL OR COINCIDENT WITH AXIS BELOW THE CROOK.

MEASUREMENT OF SHORT CROOK

NOTE:
THE THREE CASES SHOWN ARE TYPICAL AND INTENDED TO ESTABLISH THE PRINCIPLE OF MEASURING SHORT CROOKS. THERE MAY BE OTHER CASES NOT EXACTLY LIKE THOSE ILLUSTRATED.

NOT TO SCALE

ALL DIMENSIONS ARE IN MILLIMETRES UNLESS OTHERWISE NOTED

REVERSE SWEEP IN PILES

SP906-02



REVERSE SWEEP IN PILES

NOTES: WHEN CONDITIONS OF DESIGN REQUIRE, THE FOLLOWING REQUIREMENTS APPLY:

1. FOR PILES LESS THAN 10 m IN LENGTH, A STRAIGHT LINE CONNECTING THE MID-POINT AT THE BUTT AND THE MID-POINT AT THE TIP SHALL NOT LIE LESS THAN 80 mm INSIDE THE SURFACE OF THE PILE;
2. FOR PILES 10 m AND UP TO 12 m IN LENGTH, A SIMILAR STRAIGHT LINE SHALL NOT LIE LESS THAN 50 mm INSIDE THE SURFACE OF THE PILE;
3. FOR PILES 12 m AND UP TO 15 m IN LENGTH, A SIMILAR STRAIGHT LINE SHALL NOT LIE LESS THAN 30 mm INSIDE THE SURFACE OF THE PILE; OR
4. FOR PILES OVER 15 m IN LENGTH, A SIMILAR STRAIGHT LINE SHALL NOT PASS THROUGH THE SURFACE OF THE PILE.

NOT TO SCALE

ALL DIMENSIONS ARE IN MILLIMETRES UNLESS OTHERWISE NOTED

SECTION 908

PRESERVATIVE TREATMENT - WOOD PRODUCTS

908.01 Materials = Timber, piles and glued laminated members shall conform to the requirements of:

- SS 903, Timber - Materials;
- SS 904, Timber (Treated and Untreated) - Fabrication and Handling;
- SS 905, Timber - Glued Laminated;
- SS 906, Round Timber Piles as applicable.

Preservative shall conform to the requirements of the most recent edition of CSA Standard O80, - Wood Preservation.

908.02 Treatment - All aspects of preservative treatment shall conform to the requirement of the most recent edition of CSA Standard O80 - Wood Preservation.

The type of preservative, conditioning, treatment, penetration and retention shall be appropriate for the species, size and end use of the product The appropriate "Use Category" from CSA Standard O80 and the type of preservative shall be specified for end use.

908.03 Inspection = Inspection of the treated wood shall be provided by the Contractor. And shall be performed by a third party inspection agency accredited by either the Canadian Lumber Standard Accreditation Board (CLSAB) or the American Lumber Standards Committee (ALSC) under their respective treated wood programs. Third party inspections must be performed at the treatment plant. All facilities and reasonable assistance shall be afforded by the supplier, free of cost, to the third party inspection company. They shall have free entry at all times while work of the contract is being performed, to all parts of the treating plant which concern the treatment (and all related work) of the materials ordered.

Treated wood shall be shipped from the treatment plant with an inspection report from the third party inspection agency that confirms the treated wood conforms to the requirements of CSA Standard O80. The inspection report must indicate both the "Use Category" and the type of preservative used. Payment for materials shall include the cost of third party inspection

THIS PAGE IS LEFT INTENTIONALLY BLANK

SECTION 909

TREATED WOOD FENCE POSTS

909.01 General - This Section covers the quality and manufacture of wood fence and gateposts, braces and droppers.

Wood posts and the like for fences and gates shall be supplied pressure treated in the sizes, species and grading all as required by the Purchase Order, Work Order, Contract Drawing or Specifications in conformity with this Section and as generally shown on the applicable SP741 Drawings.

Note: CSA Standards may be obtained from:

Canadian Standards Association,
13799 Commerce Parkway
Richmond, BC
V6V 2N9

<http://www.csa.ca>

909.02 Species - Round fence posts (including line, straining, corner, intersection, gate and end posts) and any required round wood braces and droppers shall be Lodge Pole Pine (Western Jack Pine) cut from live growing trees. Use of other species must be approved in writing by the Ministry Representative (cedar, either split or whole, will not be approved).

909.03 Size and Measurement

a) Round fence posts and braces shall be classified as to size on the basis of the smaller diameter and length. The diameter specified shall be minimum with a tolerance of +20 mm and the length shall not vary by more than 25 mm from that specified.

b) The maximum permitted taper shall be such that the larger diameter shall not exceed that of the specified diameter by more than 25 mm over a 2 m length of post or brace. The maximum permitted taper shall be proportional for posts and braces of lengths other than 2 m.

c) All dimensions shall apply inside the bark and to the fully seasoned and treated fence posts or braces.

d) In cases where the post or brace is not truly circular, the diameter shall be obtained by measuring the circumference and dividing by 3.14.

909.04 Prohibited Defects

All round fence posts and braces shall be free of the following defects:

- Decay
- Shakes in the top or butt
- Cracks, splits, through checks
- Spike knots and knot clusters
- Unsound scars
- Reverse sweep

909.05 Limited Defects

All round fence posts and braces are permitted limited defects as follows:

- Seasoning checks less than 10 mm in width if less than 500 mm in length, or less than 5 mm in width if more than 500 mm in length
- Sound scars permitted except within 150 mm from the ends
- Sound, tight, well-spaced knots permitted provided they do not exceed 35 mm in diameter
- Sweep less than 2% of the length of the post
- Short crook less than 2% of the length of the post
- Insect damage consisting of holes 1.6 mm or less in diameter and surface scoring or channelling are permitted. All other forms of insect damage are prohibited.

Note: Defects listed above are as defined in SS_906 - Appendix A.

909.06 Manufacturing Requirements - Round Fence Posts and Braces

Ends of posts and braces shall be cut square to the specified length and unless otherwise specified on the Purchase Order, Work Order, or Drawings, one end of posts shall be machine pointed before treatment to permit driving of posts. The diameter at the point shall be not less than 18 mm and not more than 35 mm, and the taper shall extend over a length of 150 mm to 200 mm of the post, or opposite sides shall be tapered to a "chisel point" of similar basic dimensions.

Posts and braces shall be clean peeled with minimum removal of sapwood for their full length and all rough bark and inner bark removed.

All knots or projections shall be shaved smooth and flush with the surface of the surrounding wood.

All round fence posts and braces shall be air seasoned in accordance with CSA Standard O80-M1 Para. 1.31 to a moisture content of 15% to 22% before pressure treatment. In exceptional circumstances, the Ministry Representative may permit conditioning by steaming for a total of not

SECTION 909

TREATED WOOD FENCE POSTS

more than six hours at a temperature not in excess of 115°C.

909.07 Sawn Lumber Posts and Braces - Gate posts and braces not stipulated as round, together with any anchor cleats shall be Standard and better S4S Lodgepole Pine/Western Jack Pine or Coast Douglas Fir, to the current N.L.G.A. grading rules and in the required lengths and sizes.

909.08 Fence Droppers Wood droppers to stabilize barbed wire fencing (Type C) between posts may be:

- Round Fence Posts Lodgepole Pine/Western Jack Pine of 50 mm (smaller) diameter, or
- 25 mm x 50 mm Sawn Lumber, Standard and better S4S Lodgepole Pine/Western Jack Pine or Coast Douglas Fir, to the current N.G.L.A. grading rules.

All droppers 1100 mm ± 25 mm long for 4-wire Type C fences and 1200 mm ± 25 mm for Type C and C2 fences shall be selected for freedom from knots and other imperfections injurious to strength.

Approved proprietary grooved wood droppers with necessary wire clips may be specified or approved for high-tensile smooth-wire fencing.

Note: For Type C fencing proprietary prefabricated galvanized sheet metal and clip droppers may be approved as an alternative to the above wood droppers. Galvanized twisted wire fence stays may be specified or permitted only for the extension of normal fence heights to deer height and the like.

909.09 Pressure Treatment - All fence posts, braces, anchor cleats, and droppers shall be pressure treated in accordance with CSA Standard Q80, except that the

sample zone for assay shall be 0 to 16 mm from the surface and the requirement that all borings for use in the extraction sample shall have at least 25 mm of sapwood shall be waived. If species other than Lodgepole Pine are approved, these exceptions may be altered.

909.10 Inspection - All processing of the material shall be open for inspection by the Ministry Representative or the Ministry Representative's authorized inspector and they shall have free entry to the treating plant while the work is being performed.

No material shall be shipped prior to inspection or the written release for shipment by the Ministry Representative.

Material inspected before shipment shall not bar its subsequent rejection after delivery if found to fail any requirements of this Specification. Rejected material shall be replaced at the Supplier's expense including shipping charges and removal of rejected materials, if applicable.

Note: Inspection of material already in bundles ready for shipment shall be considered as "incomplete", and the material will be subject to final inspection by the Ministry Representative only when the bundles are opened immediately prior to use.

The Supplier shall advise the Ministry Representative at least two full working days before the material is ready for inspection prior to shipment. A Supplier in a distant location or outside B.C. shall advise the Ministry Representative at least one full week before the material is ready for inspection prior to shipment. After inspection the Ministry reserves the right to conduct whatever tests are deemed necessary to confirm that the material complies with the requirements of this Specification before a release for shipment is issued.

SECTION 911

STEEL AND IRON

911.01 Scope – This standard only applies to materials used in the maintenance and rehabilitation of existing log and timber bridges and log or timber components such as log crib retaining walls, timber piers, wood sign structures, etc.

911.02 Materials - These materials shall be in accordance with the current editions of the following Specifications:

- Structural Steel, CSA Specification CAN/CSA-G40.21 Grade 260 or better
- Steel Bolts, ASTM Specification A 307
- Steel Nuts, ASTM Specification A563
- Carbon Steel Castings, ASTM Specification A 27/A 27M
- Iron Castings, ASTM Specification A 48/A 48M
- Pipe Steel, ASTM Specification A 53/A 53M

911.03 Tension and Lateral Rods - Tension and lateral rods shall be of structural steel. Upset ends shall be upset by hand or machine and welds will not be allowed. The dimensions of upset ends shall be made as shown on the plans. When upsetting by machine, the ends shall be upset to a little oversize, after which they should be heated to welding temperature and then swaged to the proper size. The nuts shall be made hexagonal, U.S. Standard sizes and threads. The threads on rods and nuts shall be full, smooth, uniform and of the same pitch throughout. They shall be such that the nuts can be run on by hand the full length of the threads on the rods without showing undue or uneven slackness.

911.04 Machine Bolts - Machine bolts shall conform to ASTM Standard A 307.

911.05 Carriage Bolts - Carriage bolts shall conform to ASTM Standard A 307. They shall be of the common type with button head, square neck and square or hex nut.

911.06 Drift Bolts or Pins - Drift bolts or pins shall be of structural steel. They shall be cut from plain, round bars unless otherwise called for on the plans or bills. The ends of drift pins or bolts shall be tapered or shaped so that the pin may be easily driven into pre-bored holes in the wood being fastened.

911.07 Dowels - Dowels shall be of structural steel. They shall be cut from plain round bars and any ragged ends shall be removed.

911.08 Lag Screws - Lag screws shall conform to ASTM Standard A 307. They shall have square heads and cone points.

911.09 Plate Washers or Wrought Washers - Plate washers or wrought washers shall be of structural steel or wrought iron; they shall be round or square as specified.

Round washers shall be according to Canadian Manufacturer's Standards. Square washers shall be made to the dimensions called for on the plans or bills.

911.10 O.G. Washers - O.G. washers shall be of cast iron. The proportions of these washers adopted by some of the manufacturers differ somewhat in detail, but to be acceptable the diameter should not be less than four times the diameter of the bolt for which it is to be used and the thickness should be approximately equal to the diameter of the bolt.

911.11 Special Castings - Special castings shall be true to pattern, free from excessive shrinkage or overrun, be made in accordance with good work practice, and be free from defects. Castings, which show defects after machining, will be rejected notwithstanding any previous acceptance at the manufacturer's works.

911.12 Steel Splice-Joint Fastenings - Plates and bars, etc., for these joints shall be of structural steel. All parts shall be made in accordance with the plans. Bolt holes shall be drilled from the solid or sub-punched and reamed. In sub-punched and reamed work, the holes shall be punched 3/16" smaller and after assembling, reamed 1/16" larger than the nominal diameter of the bolt.

911.13 Galvanizing – Galvanizing, if required, shall be in accordance with CSA Specification CAN/CSA-G164 – Table 1.

911.14 Plates - The various plates designated on the plans as gib, bearing, bed, joint, lateral, etc., shall be of structural steel.

911.15 Welding - Welding shall conform to the requirements of CSA Specification W 59.

911.16 Pipe Fastenings - Pipe fastenings shall be Schedule 80 pipe. Nuts shall be hexagonal machine lock nuts, U.S. Standard as to outside dimensions and threads. The threads on nuts and pipes shall be full, smooth, uniform and of the same pitch; they shall be such that they can be run on by hand the full length of the thread on pipe without undue or uneven slackness.

911.17 Cleaning and Painting – Painting of steel and iron components shall be in accordance with SS 216.10 Application Methods, excluding metalizing and hot dip galvanizing. No paint shall be applied to surfaces which are to be encased in concrete.

911.18 Machine Finished Surfaces - Machine finished surfaces and threaded ends of tension and lateral rods shall be coated with an anti-corrosion lubricant with white lead applied as soon as the surfaces and threads are finished and accepted by the Inspector.

911.19 Inspection - All materials and quality of work shall be subject to inspection. The manufacturer shall

SECTION 911

STEEL AND IRON

allow the authorized Inspector free access to the shops at all times when work on the materials is being done and the manufacturer shall provide every reasonable facility to assist the Inspector in the inspection of both material and quality of work. The Inspector shall have power to reject material or quality of work which do not come up to the requirements of this Specification; but in case of dispute the manufacturer may appeal to the Ministry

Representative whose decision shall be final. Rejected material or poor quality of work shall be replaced promptly or made good by the manufacturer. Tests will be made only when and as specified by the Ministry Representative.

911.20 Shipping - The threaded ends of all rods shall be protected from damage.

SECTION 917

WIRE ROPE

917.01 Wire Rope - Wire Rope shall conform to the requirements of CSA Standard G4-00 "Steel Wire Rope

for General Purpose and for Mine Hoisting and Haulage." |

THIS PAGE IS LEFT INTENTIONALLY BLANK

SECTION 933

ADMIXTURES FOR PORTLAND CEMENT CONCRETE

933.01 Scope - This Section covers general requirements for air entraining and chemical admixtures and Specification requirements for pozzolan admixtures.

933.02 Applicable standards. The standards listed in Table 933-A shall apply unless otherwise specified herein or in the Special Provisions. All referenced standards shall be to the current editions at time of tendering.

TABLE 933-A APPLICABLE STANDARDS

ASTM-C 260	Air-entraining Admixtures for Concrete
ASTM-C 494	Chemical Admixtures for Concrete
CAN/CSA A3000-03	Cementitious Materials Compendium
CAN/CSA A23.1	Concrete Materials and Methods of Concrete Construction

933.03 Air-Entraining and Chemical Admixtures

- a) Air-entraining admixtures shall conform to the requirements of ASTM Standard C 260, Air-Entraining Admixtures for Concrete.
- b) Chemical Admixtures shall conform to the requirements of ASTM Standard C 494, Chemical Admixtures for Concrete.

933.04 Pozzolan Admixtures

933.04.01 Definitions:

- i) **Type N Pozzolan** - A natural pozzolan consisting of siliceous or aluminosiliceous material in finely divided form and in the presence of moisture chemically reacts at ordinary room temperatures with calcium hydroxide, released by the hydration of portland cement, to form compounds possessing cementing properties.
- ii) **Type F Pozzolan** - A finely divided residue that results from the combustion of pulverized coal and that is carried from the combustion chamber of a furnace by exhaust gasses.

933.04.02 General - When types N or F pozzolans are used in concrete either as a cement replacement, addition, or both, they shall contribute to the beneficial physical and chemical properties of the hardened concrete through pozzolanic activity. Before a pozzolan is accepted for use in concrete, the pozzolan shall first meet the physical and chemical requirements herein specified.

If suitable, the pozzolan shall then be evaluated upon its performance in laboratory concrete trial mixes at various usage rates. Any pozzolan which does not produce the specified effects or produces adverse effects to concrete shall not be used.

933.04.03 Sampling and Testing - Types N and F pozzolans shall be sampled and tested for chemical and physical properties in accordance with ASTM-C 311 "Standard Test Methods for Sampling and Testing of Fly Ash or Natural Pozzolans for Use in Portland Cement Concrete", unless otherwise specified in these specifications.

933.04.04 Chemical Requirements - The chemical requirements for types N and F pozzolans shall be as shown in Table 933-B.

933.04.05 Physical Requirements

i) **Fineness** - The fineness of either types N or F pozzolan will be determined in accordance with ASTM C 311 Section 20, "Fineness, Amount Retained When Wet-Sieved on a 45 µm (No. 325) Sieve" and/or ASTM C 204 for "Fineness of Hydraulic Cement by Air Permeability Apparatus". In this latter procedure, fineness shall be determined by use of the Blaine permeability apparatus except that pozzolan will be used in place of cement.

The degree of fineness of either type N or F pozzolan shall be that which produces the optimum pozzolanic activity with the Portland cement with which the pozzolan is to be used. The pozzolanic activity index shall not be less than 75% of the control at 28 days. After six months storage, pozzolans shall be retested for fineness.

ii) **Water Requirements** - Water requirements for mortar made with the pozzolan in accordance with ASTM C 311 Section 31 shall not be greater than 115% of water used in the control mix.

iii) **Drying Shrinkage** - Increase in drying shrinkage of mortar bars made and tested in accordance with ASTM C 311 Sections 21-23 shall not be greater than 0.03%.

iv) **Soundness** - When tested for soundness in accordance with ASTM C 311 Section 24 the expansion or contraction after autoclaving shall not be greater than 0.08%.

933.04.06 Performance Evaluation of Types N or F Pozzolans in Concrete

i) Only pozzolans which meet the physical and chemical requirements of these Specifications shall be evaluated for use in concrete.

SECTION 933

ADMIXTURES FOR PORTLAND CEMENT CONCRETE

ii) Evaluation of pozzolans in concrete shall be made with laboratory concrete trial mixes preferably with concrete ingredients to be used on the job where the pozzolanic concrete is to be used.

iii) Evaluation shall be made by comparing test results of the pozzolanic mixes with test results of similar concrete mixes without pozzolan.

iv) The Ministry Representative may specify tests to evaluate the performance of a pozzolan in a specific concrete as provided in Table 933-C.

933.04.07 Basis of Evaluation - Types N and F pozzolans shall be evaluated in concretes by comparing results of tests performed on "job design" portland cement concrete with similar class portland cement concrete without pozzolan. Types N and F pozzolans will only be considered for acceptance when they produce equal or better test results than those obtained with similar class concrete without pozzolan and are economic. When accepted, types N and F pozzolans shall only be used at dosage rates determined from test results and accepted by the Ministry Representative.

TABLE 933-B CHEMICAL REQUIREMENTS FOR TYPES N AND F POZZOLANS

CHEMICAL REQUIREMENTS:	POZZOLAN TYPE	
	N	F
Silicon dioxide (SiO ₂) plus aluminum oxide (Al ₂ O ₃) plus iron oxide (Fe ₂ O ₃), minimum %	70.0	70.0
Sulphur trioxide (SO ₃), maximum %	4.0	5.0
Moisture content, maximum %	3.0	3.0
Loss on ignition, maximum %	10.0	12.0
Magnesium oxide (MgO), maximum %	5.0	5.0
Available alkalis, as Na ₂ O, maximum %	1.5	1.5

TABLE 933-C TESTS FOR EVALUATING THE PERFORMANCE OF A POZZOLAN IN A SPECIFIC CONCRETE

QUALITY REQUIREMENTS	TITLE OF TEST	TEST DESIGNATION
Air Entrainment	Limits of Amount of Air-Entraining Admixture in Concrete	ASTM C 311 Sections 25 and 26
Bleeding	Bleeding of Concrete	ASTM C 232
Setting Time	Time of Setting of Concrete Mixtures by Penetration Resistance	ASTM C 403
Compressive Strength	Concrete Test Specimens Making and Curing in the Laboratory	ASTM C 192
Flexural Strength	Flexural Strength of Concrete (Using Simple Beam with Third-Point Loading)	ASTM C 78
Drying Shrinkage	Length Change of Hardened Cement Mortar and Concrete	ASTM C 157
Thermal Volume Change	Early Volume Change of Cementitious Mixtures	ASTM C 827
Alkali Reaction	Effectiveness of Mineral Admixtures in Preventing Excessive Expansion of Concrete Due to the Alkali-Aggregate Reaction	ASTM C 441
Resistance to Freezing and Thawing	Resistance of Concrete to Rapid Freezing and Thawing	ASTM C 666
Resistance to De-icing Chemicals	Scaling Resistance of Concrete Surfaces Exposed to De-icing Chemicals	ASTM C 672

SECTION 941

PRECAST REINFORCED CONCRETE BARRIERS

941.01 Scope - This Section covers the quality and manufacture of precast reinforced concrete roadside and median barriers for highway and other off-highway traffic confinement use.

The concrete traffic barrier units shall be supplied in the sizes and types as required by the Purchase Order, Work Order or Drawing in strict conformity with this Section and pertinent Standard Drawings of the SP941 Series.

941.02 Concrete Quality

- a) Concrete quality shall conform to CSA Standard CAN3-A23.1-M except where amended hereafter.
- b) A compressive strength test result is defined as the average of the strengths of three 28 day compressive test cylinder breaks with standard cylinders of 150 mm diameter and 300 mm high size.
- c) The strength level of the concrete represented by the test shall be considered satisfactory if the test result equals or exceeds 30 MPa and no individual cylinder strength is less than 27 MPa. If this condition is not met, the concrete will be considered to have failed the strength requirements. No other form of testing to prove the relative strength at a later date will be allowed without the approval of the Ministry Representative.
- d) Cylinders shall be cast by the Ministry Representative or his authorized representative at the time of placing concrete. Frequency of testing will be at the discretion of the Ministry Representative.
- e) Calcium chloride or admixtures containing calcium chloride shall not be used in the concrete.
- f) Concrete shall meet the following additional requirements:
 - i) Minimum cement content of 320 kg per cubic metre.
 - ii) Maximum water/cement ratio of 0.45.
 - iii) Coarse aggregate of a nominal maximum size not exceeding 28 mm.
 - iv) Slump of 50 mm \pm 20 mm.
 - v) Entrained air of 5 to 8%.

941.03 Reinforcing Steel, Attachment Hardware & Miscellaneous Items

- a) Welded steel wire mesh reinforcement shall be supplied and installed in each section as shown on the Standard Drawings, and in accordance with SS 412. Additional reinforcement may be installed to assist handling during the precasting operations but shall be subject to prior approval by the Ministry Representative.

- b) Reinforcing steel for bent and hooked connections shall conform to CSA CAN3-G40.21-M Grade 260W and shall be carefully bent to the radii detailed and installed as shown on the Standard Drawings.

Bending shall be done by methods that will not produce fracture or other injury. The metal heating shall not be to a higher temperature than that producing a "dark cherry red" colour. After heating, the metal shall be cooled as slowly as possible. Following the bending, the surface of the metal shall be carefully inspected for evidence of fracture, and any fractured pieces shall be replaced.

Prior to delivery, exposed surfaces of connections shall be prepared for and given a heavy application of zinc rich coating to CGSB Standard 1-GP-181M.

- c) Pick-up points for handling units shall be formed with accurately placed rigid P.V.C. pipe recessed 15 mm from both finished surfaces as detailed.

941.04 Optional Features - Where barrier is ordered with drainage slots or grouting holes or both, they shall be accurately cast-in as detailed. Facilities for the installation of anti-glare screens will be detailed as and when required.

941.05 Placing and Finishing of Concrete

- a) Concrete shall be placed in the forms and carefully consolidated in strict accordance with CSA CAN3-A23.4-M, Clause 19.
- b) Curing and protection shall be carried out strictly according to CSA CAN3-A23.4-M Clause 21.
 - i) Curing shall be considered complete when test cylinders reach the specified 28 day compressive strength provided such strength is reached not later than 28 days after the barriers are cast.
 - ii) Steam curing is permissible for either the entire curing period or portion thereof and shall be carried out in accordance with CSA CAN3-A23.4-M Clause 21.4.
 - iii) At no time during or at completion of the curing period shall the temperature differential between the concrete surface and the ambient temperature be greater than 20°C.
 - iv) If steam is used for a portion of the curing period, additional normal curing shall be carried out after the steam curing, according to CSA CAN3-A23.4-M Clause 21.3 until such time as strength tests of concrete test cylinders that have been both steam and normally cured with the barriers reach the specified concrete strength.
- c) Exposed surfaces shall be uniform in texture and colour as produced from well maintained steel form

SECTION 941

surfaces and proper vibration methods without excessive surface fines or laitance.

d) Defects of the exposed surface will normally be cause for the rejection of any unit except where such are within the permissible limits or are subject to making good as follows:

i) Unobtrusive defects of any kind where their total area is not in excess of 2% of the exposed surface area of the unit.

ii) Air holes not greater than 3 mm in diameter and not more than 20 in any isolated 300 mm X 300 mm area.

iii) Sharp arises at the edges of the exposed surfaces where necessary shall be softened by careful rubbing or grinding.

iv) Patching of isolated small holes, cavities and similar self-confining defects may be permitted when authorized in writing by the Ministry Representative.

e) Patching, only when authorized, shall have the defective area well saturated with water and the defect prepared with cement paste and filled with mortar. The mortar, properly proportioned of the same sand and cement as the original concrete and reasonably colour matched to the cured dry unit with the addition of white cement where necessary, shall be pre-shrunk for about one hour before retempering and use. The patching mortar shall be well tooled in, finished flush and smooth and the area covered to cure adequately.

f) End connection surfaces shall be cleared out.

PRECAST REINFORCED CONCRETE BARRIERS

g) All concrete surfaces prior to shipment shall be accurate to detail and, in particular at the end connections, true to dimension tolerances.

941.06 Tolerances - Tolerances allowable in concrete dimensions of the barriers shall be ± 3 mm except as otherwise indicated on the detail drawings.

941.07 Procedure of Manufacture - The Supplier shall notify the Ministry in advance concerning the date when the order is to be manufactured, so that detailed inspection can be carried out. All processes shall be open for inspection and approval by the Ministry Representative. No material shall be shipped prior to the inspection or written release for shipment by the Ministry Representative.

The manufacturer's name or trade mark, year of manufacture and form number shall be embedded on the end of each unit in a manner, size and depth that they are permanently legible.

Authorized patching or making good may be inspected before shipment or upon delivery and the rejected unit(s) shall be replaced at no cost to the Ministry.

941.08 Handling - In handling the finished product, the concrete and connecting devices shall not be damaged or distorted.

941.09 Payment - Payment shall be at unit price bid per unit (section). The price bid shall be full compensation for everything furnished and done including supply of forms and all materials, placing, vibrating and curing air entrained concrete, stripping, finishing, general clean-up and delivery.

PRECAST CONCRETE BULL-NOSE
460 mm - CBN-H & CBN-E

SP941-01.01.01

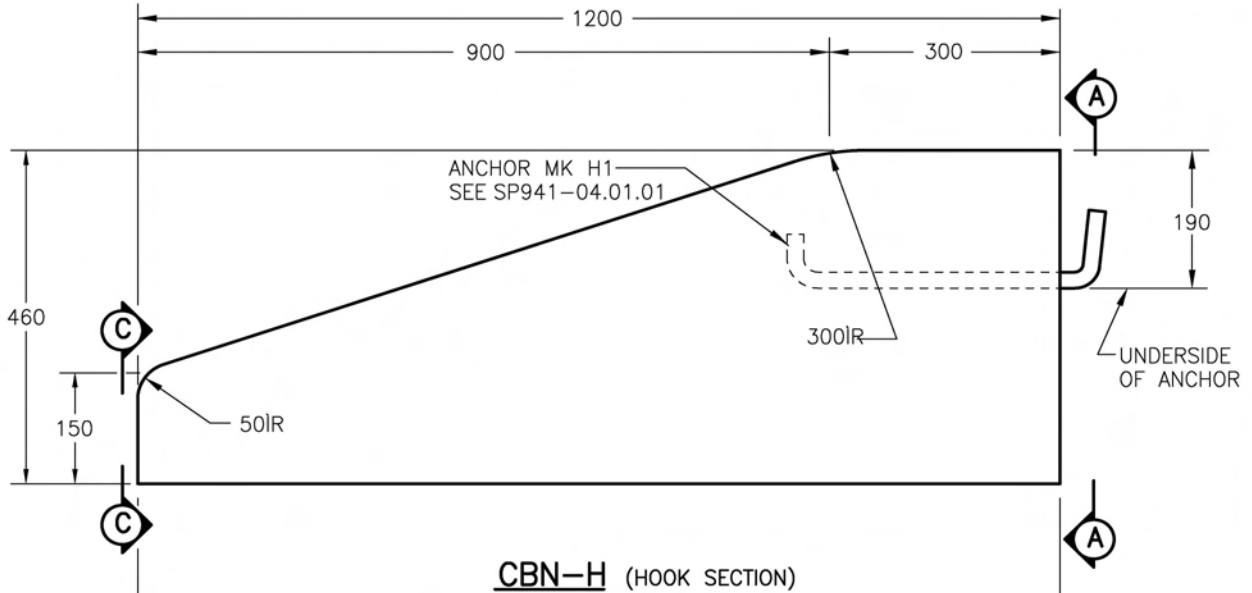

CBN-H (HOOK SECTION)

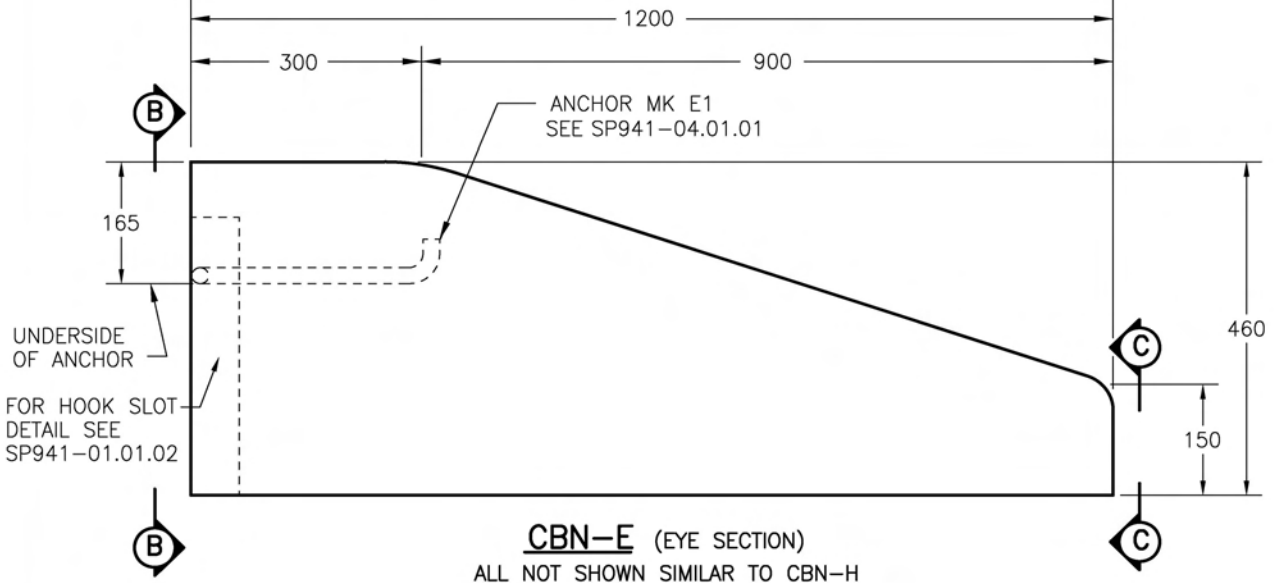

CBN-E (EYE SECTION)

ALL NOT SHOWN SIMILAR TO CBN-H

ELEVATION

GENERAL NOTES:

1. FOR VIEW (A) & (B) SEE SP941-01.01.02
2. FIBRILATED FIBRE STRAND REINFORCED CONCRETE TO BE USED FOR BULL-NOSE (CBN).
3. FIBRILATED FIBRE STRAND REINFORCED CONCRETE MAY BE SUBSTITUTED FOR STEEL REINFORCED CONCRETE IN LOW BARRIER (CLB-H & E).
4. MATERIALS AND QUALITY OF WORK TO BE IN ACCORDANCE WITH SECTION 941.
5. STANDARD CBN-E MAY BE MANUFACTURED ONLY WITH PRIOR WRITTEN PERMISSION FROM THE HIGHWAY SAFETY BRANCH.

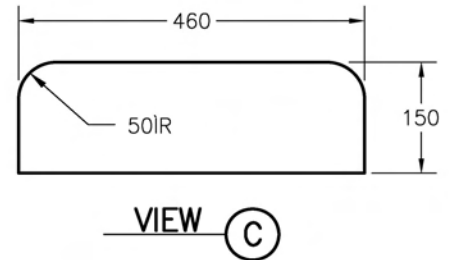

NOT TO SCALE

ALL DIMENSIONS ARE IN MILLIMETRES UNLESS OTHERWISE NOTED

PRECAST CONCRETE LOW BARRIER
460 mm - CLB-E+H

SP941-01.01.02

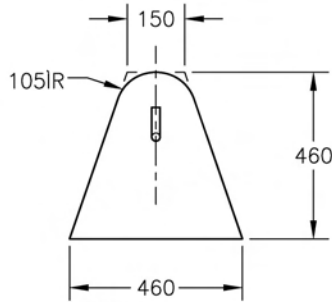
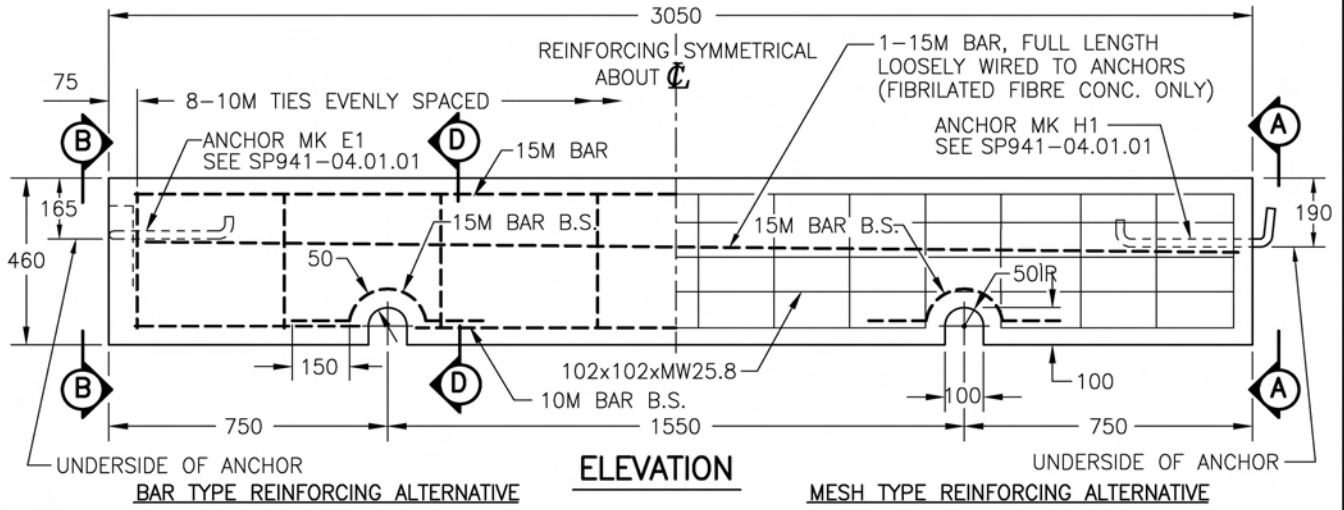

VIEW (HOOK END) A

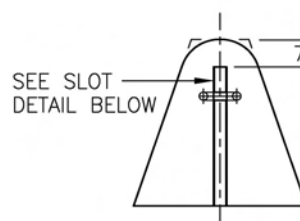

VIEW (EYE END) B

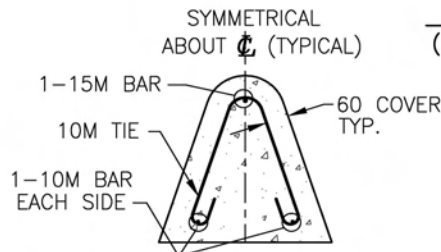

SECTION (BAR REINFORCING ALTERNATIVE) D

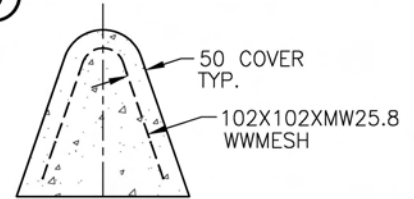

SECTION (MESH REINFORCING ALTERNATIVE) D

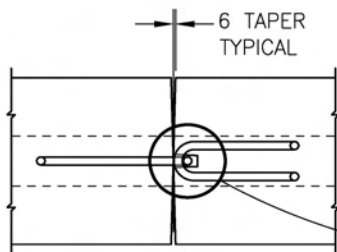

HOOK AND EYE DETAIL

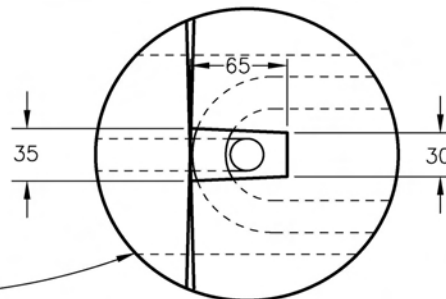

HOOK SLOT DETAIL

NOTE: FOR GENERAL NOTES SEE SP941-01.01.01

NOT TO SCALE

ALL DIMENSIONS ARE IN MILLIMETRES UNLESS OTHERWISE NOTED

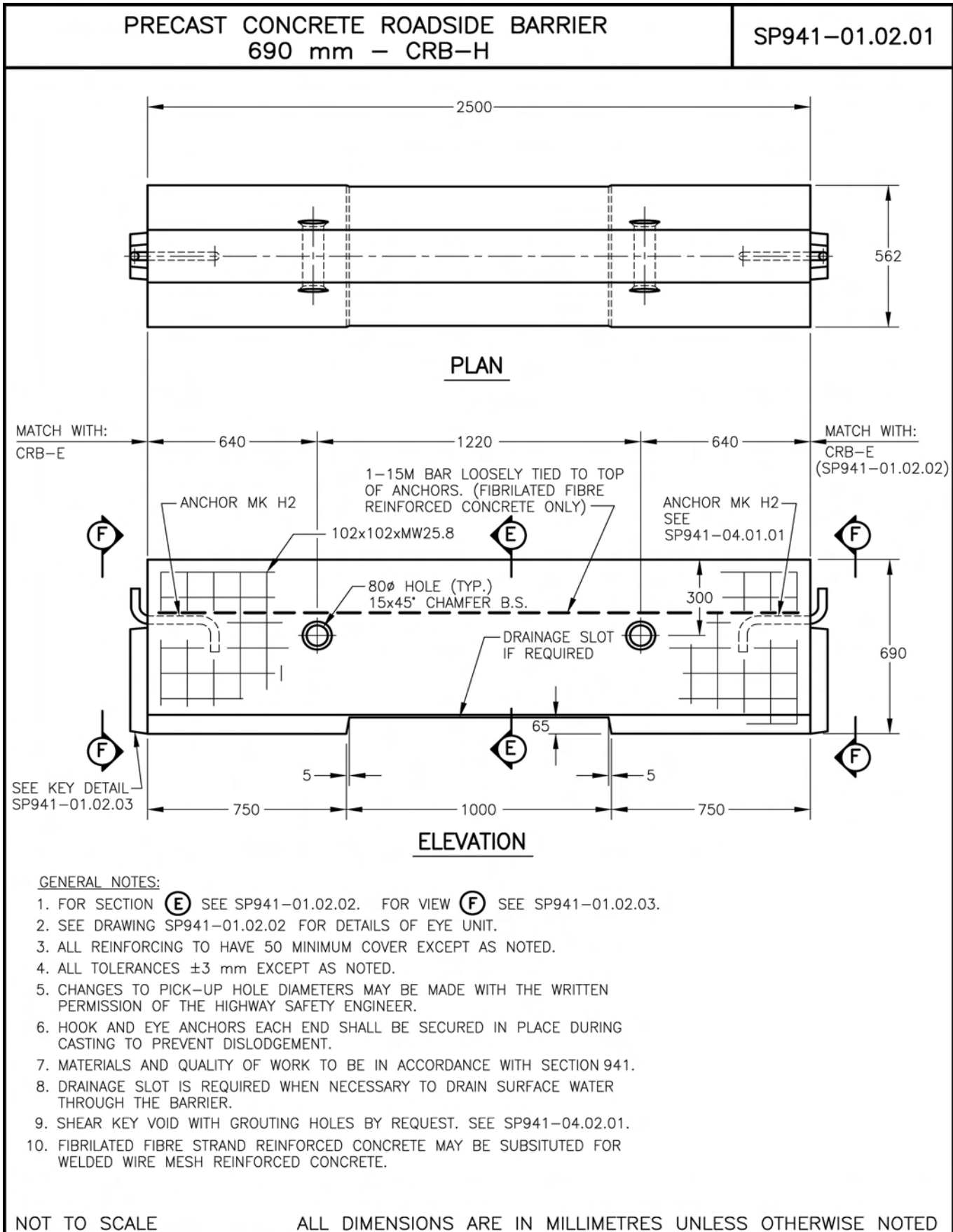

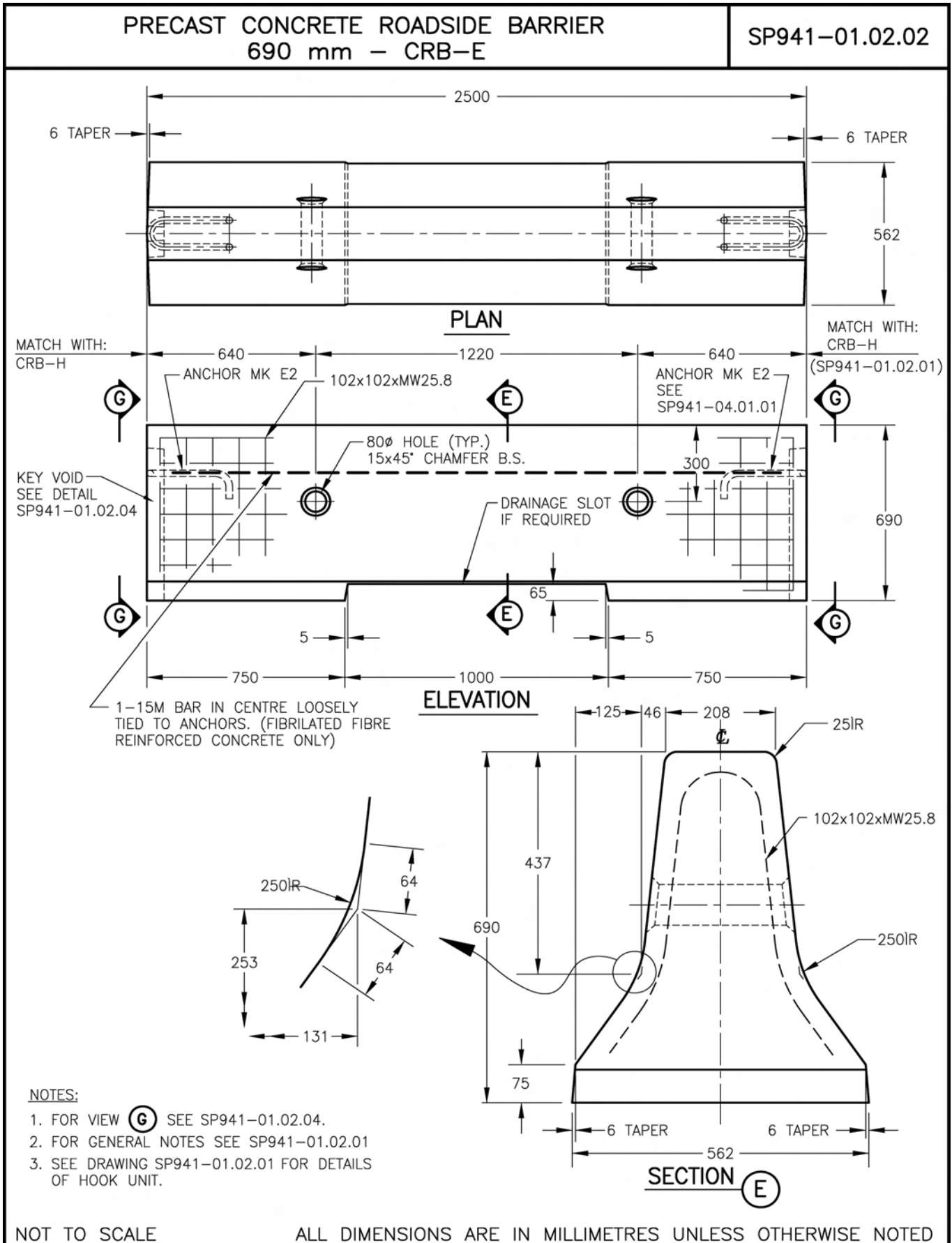

PRECAST CONCRETE ROADSIDE BARRIER
690 mm – CRB-H DETAILS

SP941-01.02.03

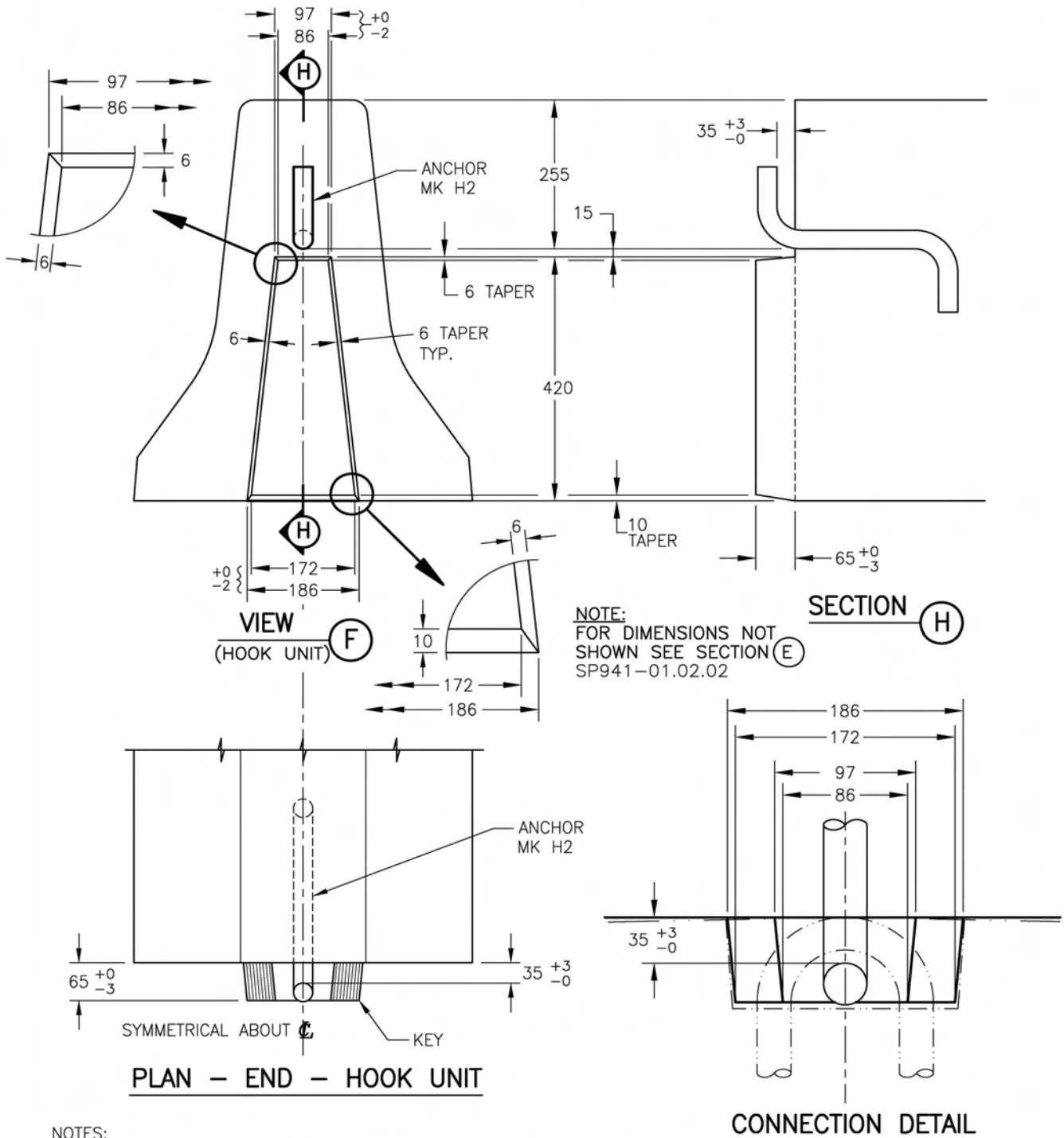

NOTES:

1. FOR LOCATION OF VIEW (F) SEE SP941-01.02.01, SP941-03.02.01, SP941-03.03.01 & SP941-03.03.03.
2. FOR GENERAL NOTES SEE SP941-01.02.01
3. FOR DETAILS OF ANCHORS SEE SP941-04.01.01.
4. THE CONNECTION DIMENSIONS ON A CRB-E UNIT PERMIT INSTALLATION TO A MINIMUM HORIZONTAL CURVE RADIUS OF 51 METRES. FOR TIGHT CURVATURE INSTALLATION SEE SP941-02.01.08 & SP941-02.01.09.

NOT TO SCALE

ALL DIMENSIONS ARE IN MILLIMETRES UNLESS OTHERWISE NOTED

PRECAST CONCRETE MEDIAN BARRIER
810 mm - CMB-E DETAILS

SP941-02.01.04

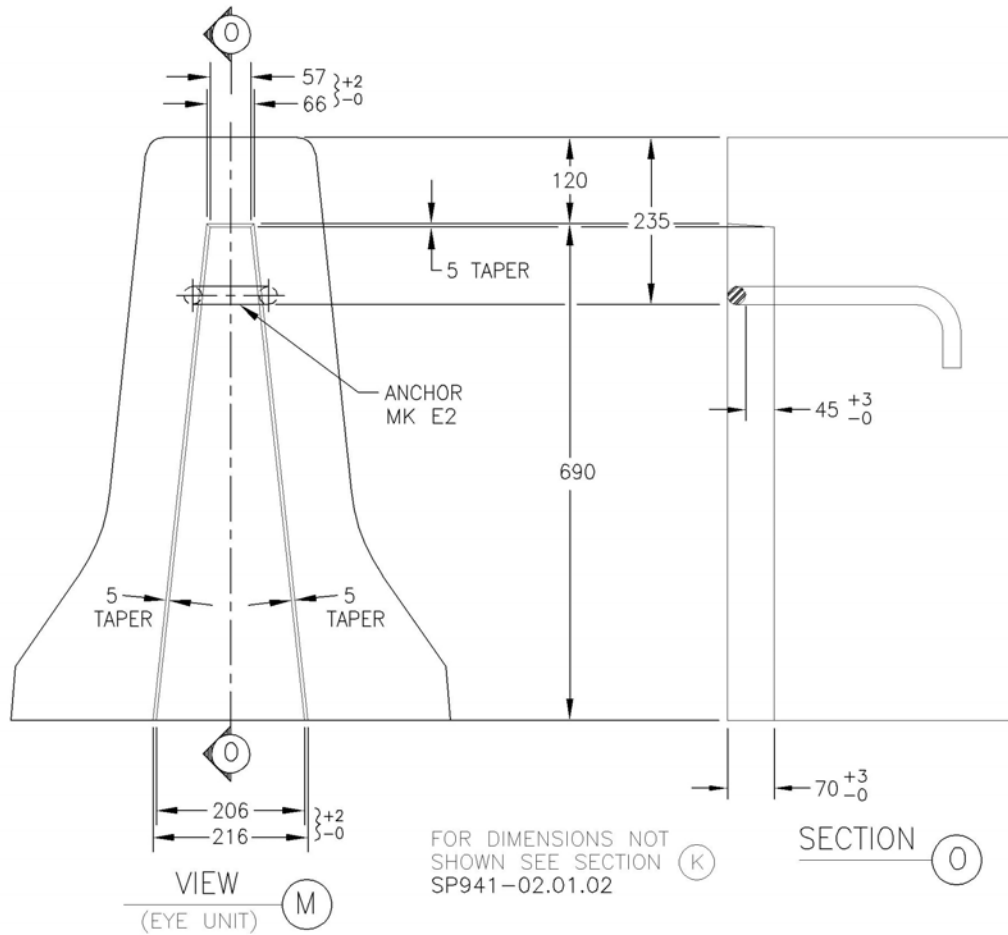

FOR DIMENSIONS NOT SHOWN SEE SECTION (K)

SECTION (O)

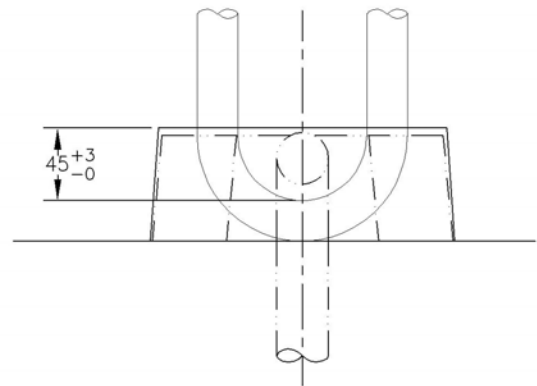
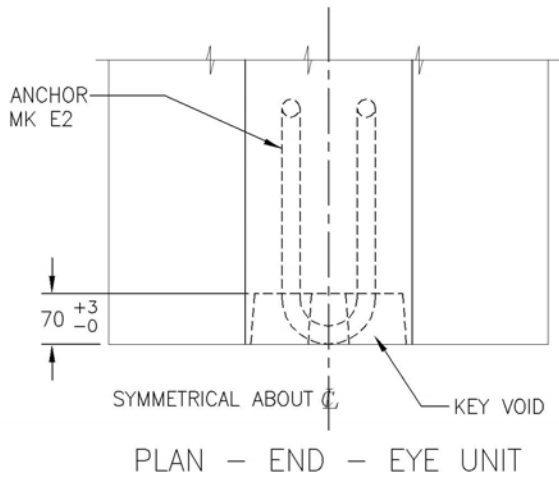

NOTES:

1. FOR LOCATION OF VIEW (M) SEE SP941-02.01.02.
2. FOR GENERAL NOTES SEE SP941-01.02.01.
3. FOR DETAILS OF ANCHORS SEE SP941-04.01.01.
4. THE CONNECTION DIMENSIONS PERMIT INSTALLATION TO A MINIMUM HORIZONTAL CURVE RADIUS OF 95.5 METRES.

NOT TO SCALE

ALL DIMENSIONS ARE IN MILLIMETRES UNLESS OTHERWISE NOTED

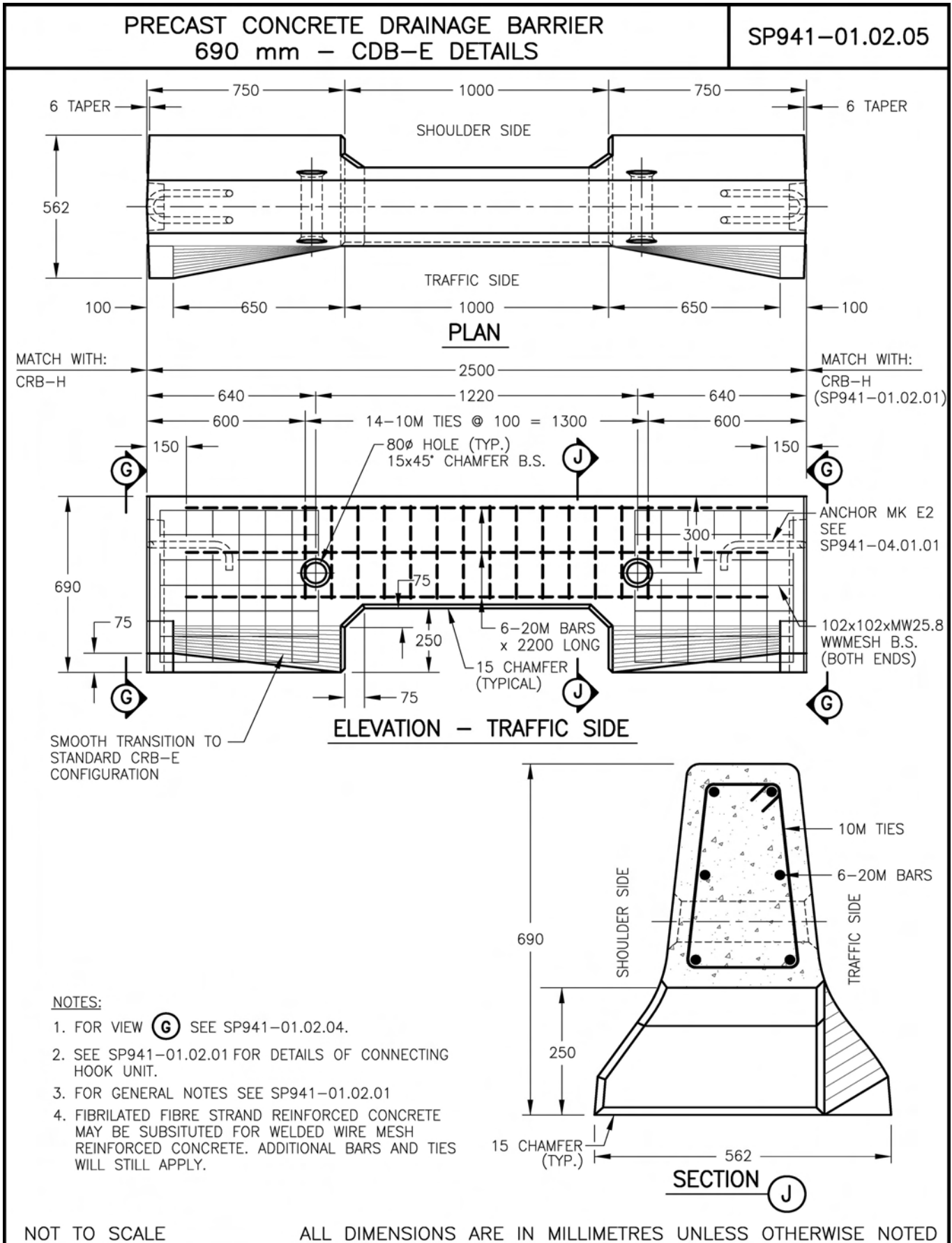

NOTES:

1. FOR VIEW (G) SEE SP941-01.02.04.
2. SEE SP941-01.02.01 FOR DETAILS OF CONNECTING HOOK UNIT.
3. FOR GENERAL NOTES SEE SP941-01.02.01
4. FIBRILATED FIBRE STRAND REINFORCED CONCRETE MAY BE SUBSTITUTED FOR WELDED WIRE MESH REINFORCED CONCRETE. ADDITIONAL BARS AND TIES WILL STILL APPLY.

NOT TO SCALE

ALL DIMENSIONS ARE IN MILLIMETRES UNLESS OTHERWISE NOTED

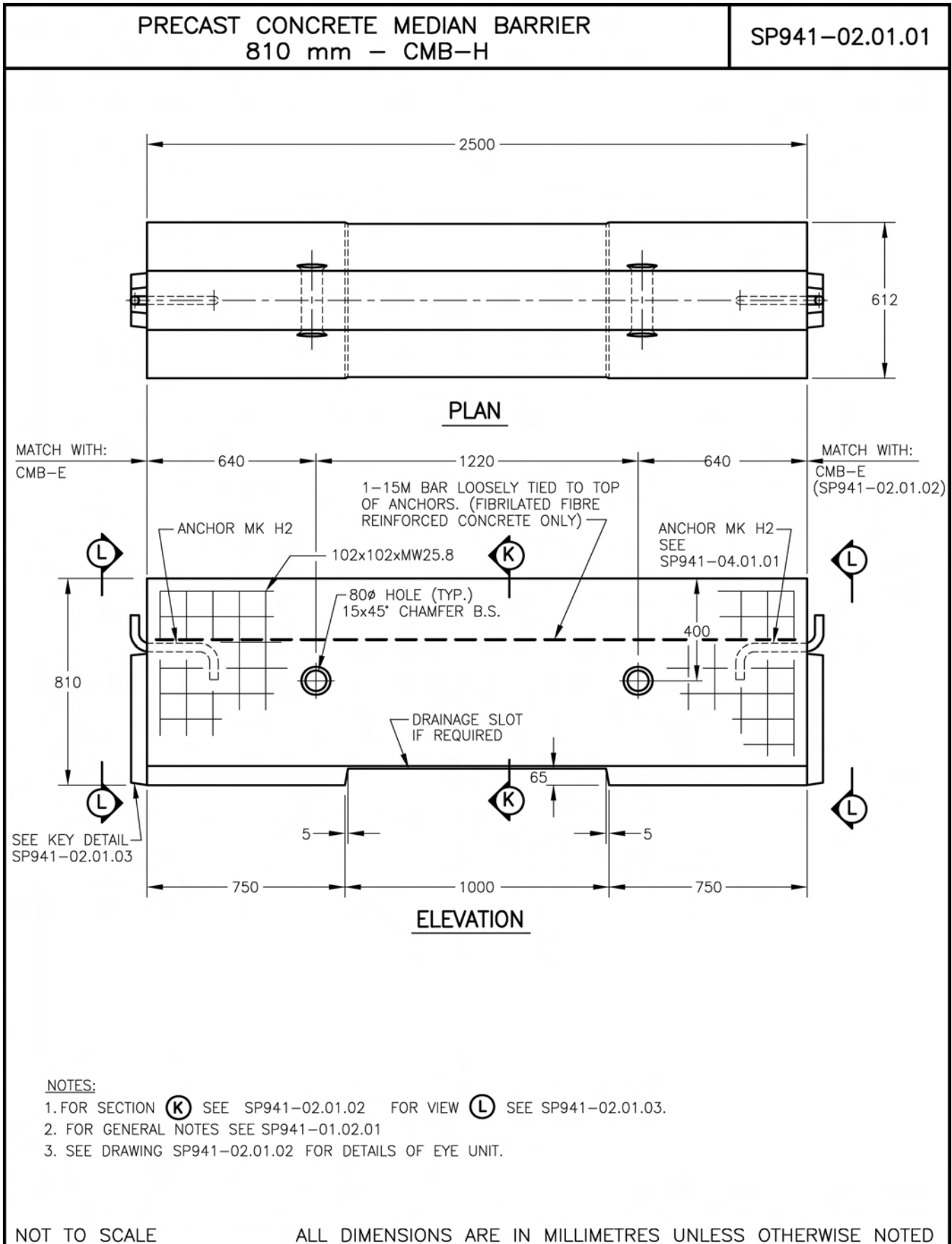

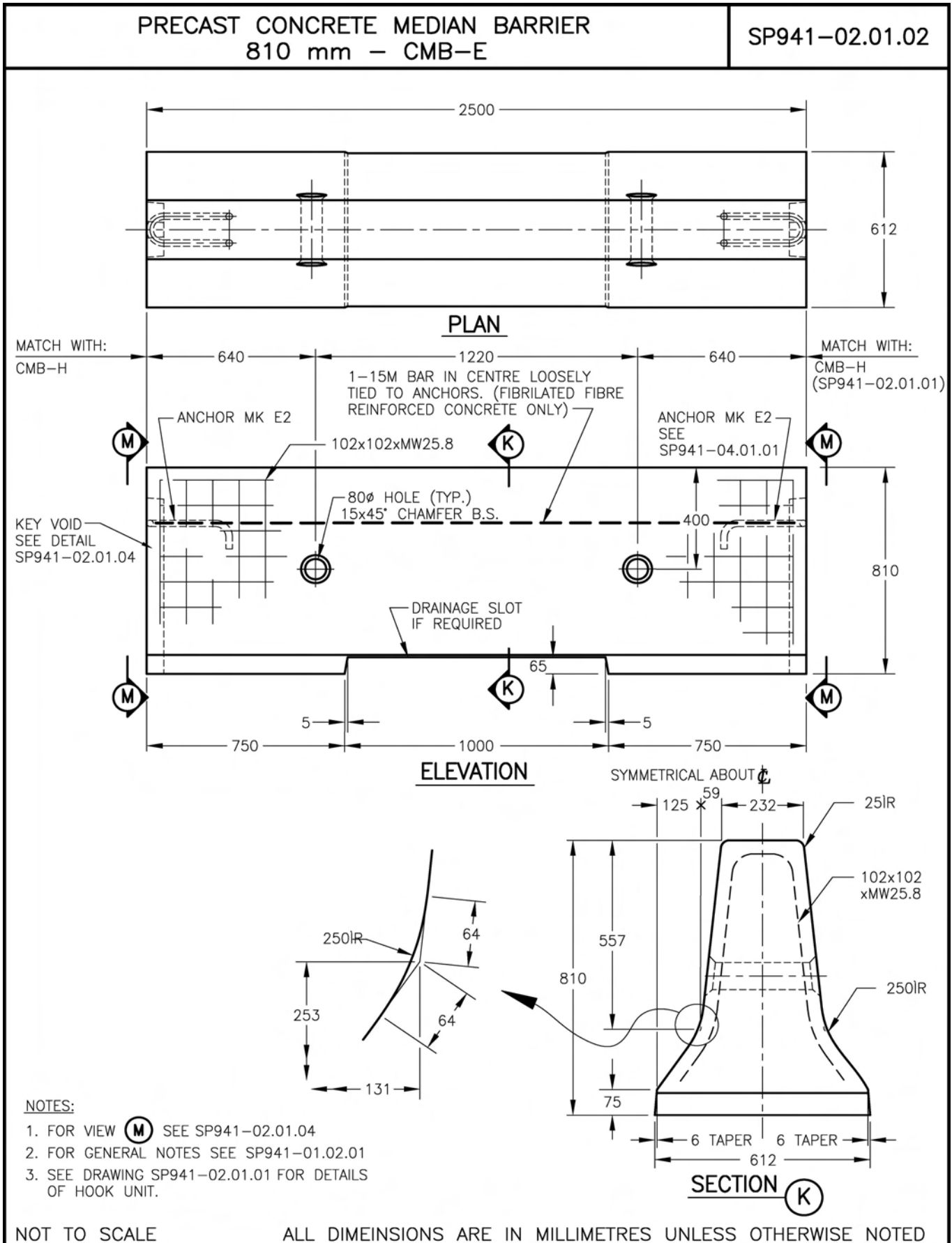

PRECAST CONCRETE MEDIAN BARRIER
810 mm – CMB-H DETAILS

SP941-02.01.03

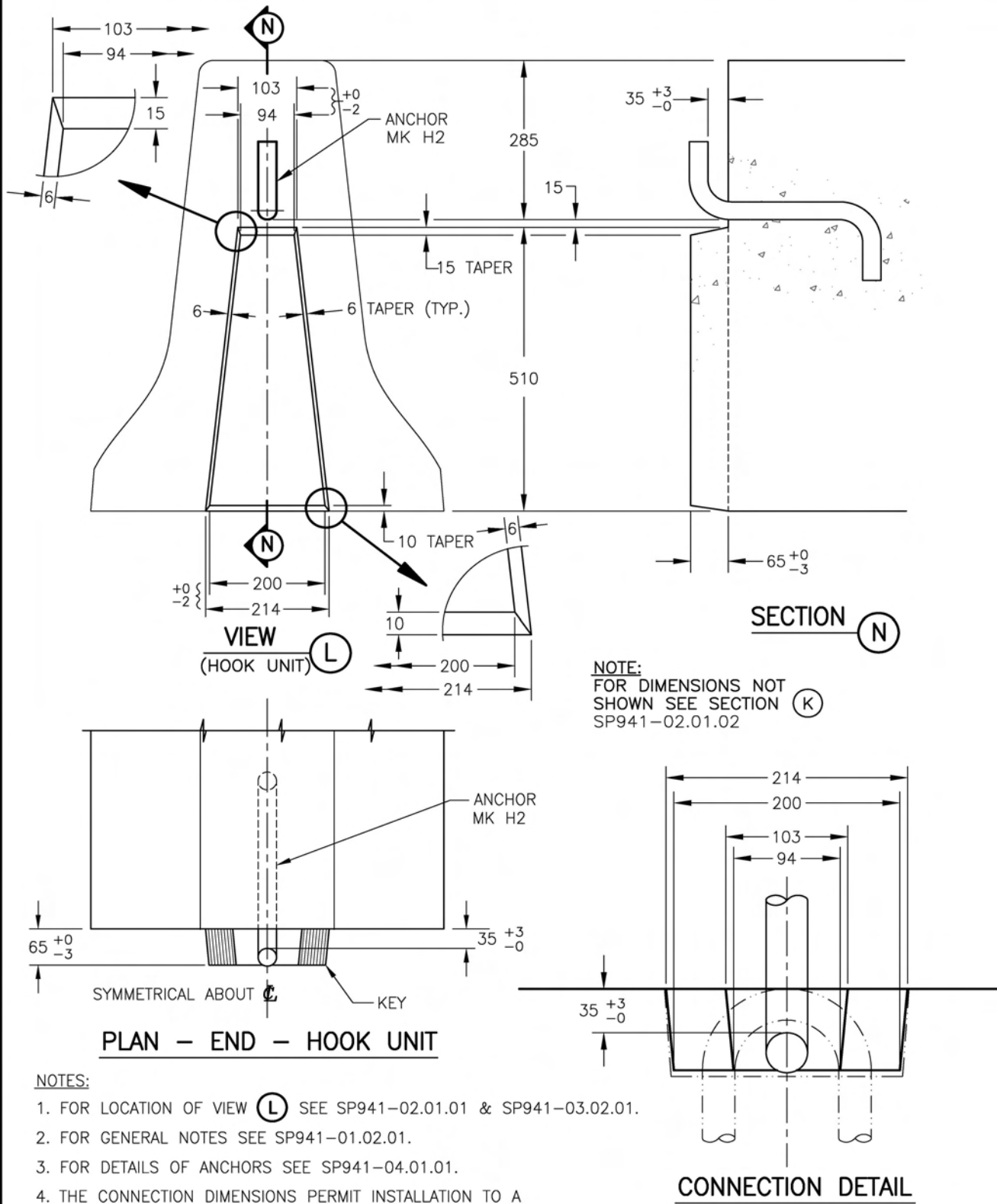

NOTES:

1. FOR LOCATION OF VIEW L SEE SP941-02.01.01 & SP941-03.02.01.
2. FOR GENERAL NOTES SEE SP941-01.02.01.
3. FOR DETAILS OF ANCHORS SEE SP941-04.01.01.
4. THE CONNECTION DIMENSIONS PERMIT INSTALLATION TO A MINIMUM HORIZONTAL CURVE RADIUS OF 95.5 METRES.

NOT TO SCALE

ALL DIMENSIONS ARE IN MILLIMETRES UNLESS OTHERWISE NOTED

PRECAST CONCRETE MEDIAN BARRIER
810 mm – CMB-E DETAILS

SP941-02.01.04

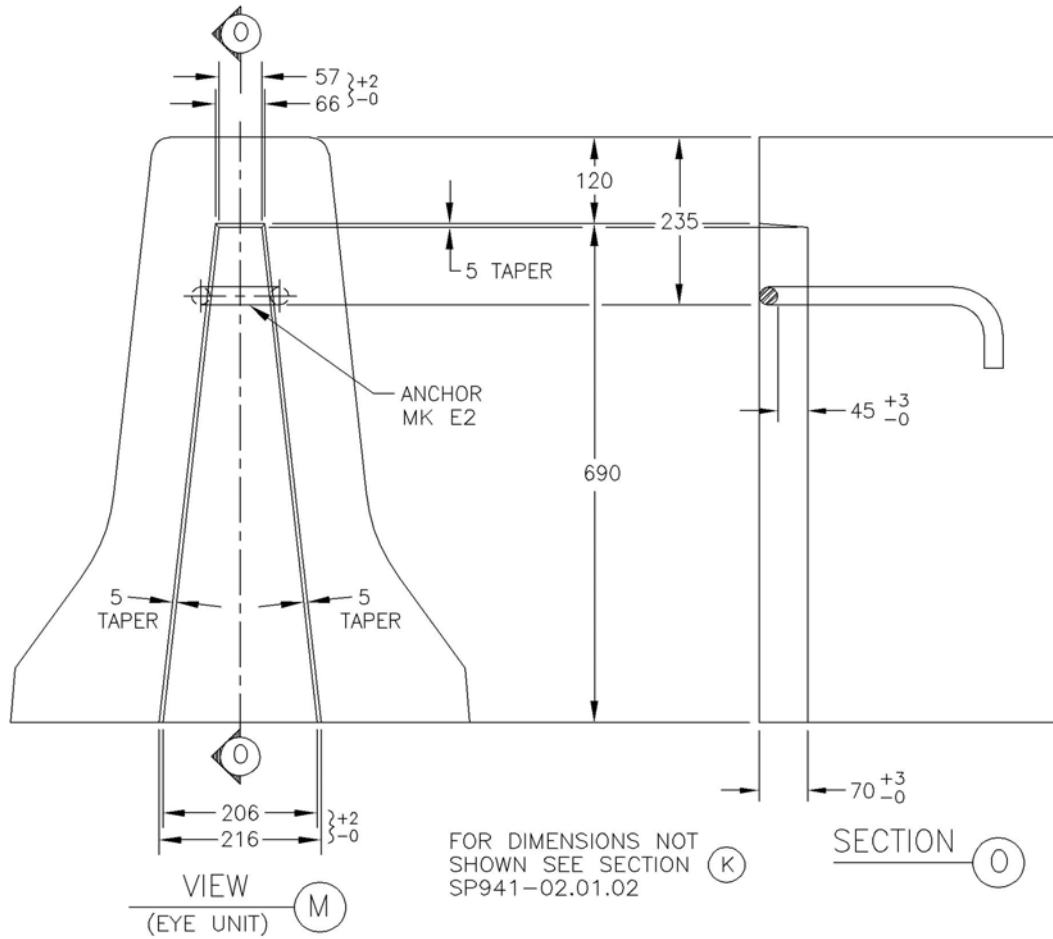

VIEW (EYE UNIT) (M)

FOR DIMENSIONS NOT SHOWN SEE SECTION (K)

SECTION (O)

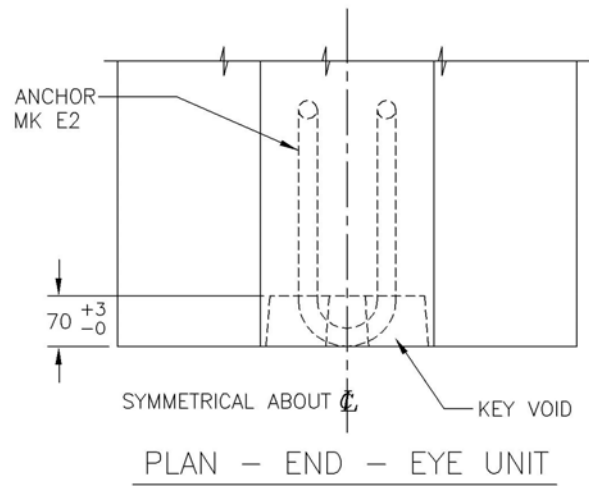

PLAN - END - EYE UNIT

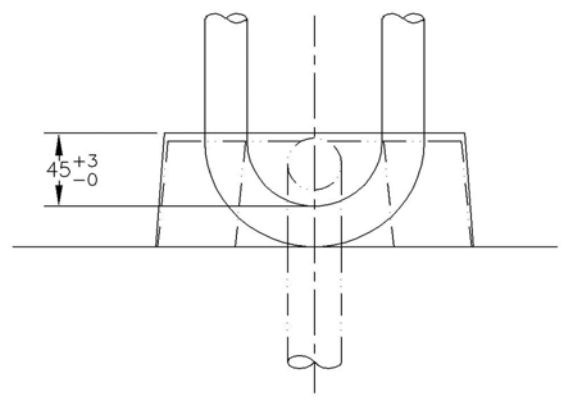

CONNECTION DETAIL

NOTES:

1. FOR LOCATION OF VIEW (M) SEE SP941-02.01.02.
2. FOR GENERAL NOTES SEE SP941-01.02.01.
3. FOR DETAILS OF ANCHORS SEE SP941-04.01.01.
4. THE CONNECTION DIMENSIONS PERMIT INSTALLATION TO A MINIMUM HORIZONTAL CURVE RADIUS OF 95.5 METRES.

NOT TO SCALE

ALL DIMENSIONS ARE IN MILLIMETRES UNLESS OTHERWISE NOTED

PRECAST CONCRETE PIER BARRIER
810 mm - CPB-H

SP941-02.01.05

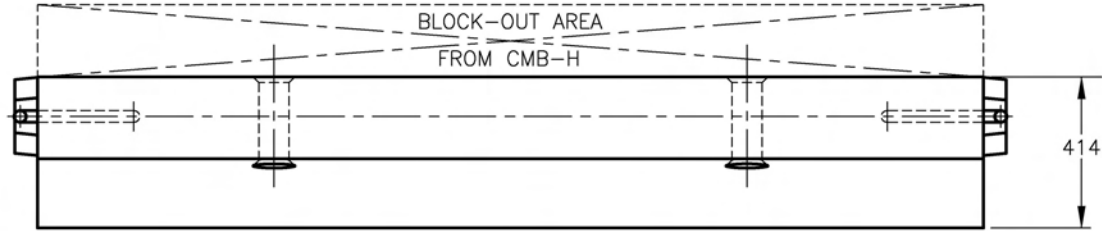

PLAN

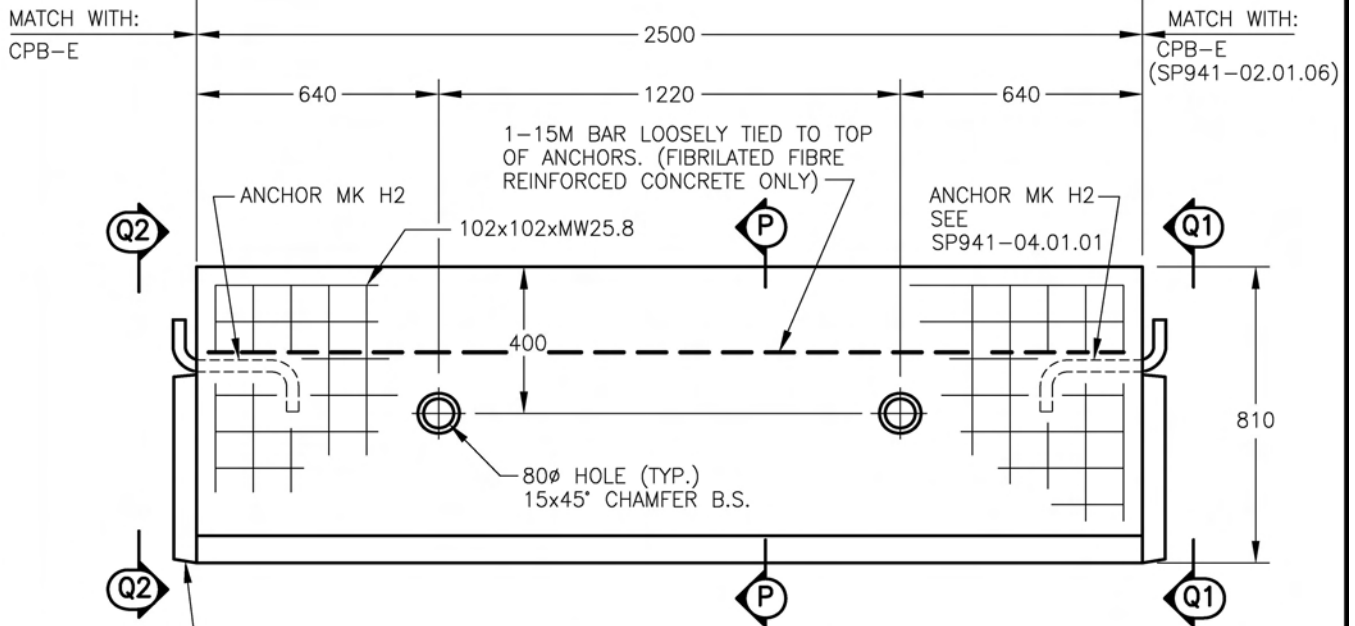

ELEVATION

NOTES:

1. FOR SECTION (P) SEE SP941-02.01.06.
FOR VIEW (Q1) & (Q2) SEE SP941-02.01.07.
2. FOR GENERAL NOTES SEE SP941-01.02.01
3. SEE DRAWING SP941-02.01.06 FOR DETAILS OF EYE UNIT.
4. THESE UNITS ARE INTENDED TO BE USED AGAINST BRIDGE SUPPORT STRUCTURES AND SIMILAR WALLS.
5. IT IS INTENDED THAT EXISTING CMB MOLDS WILL BE ADAPTED TO PRODUCE THESE CPB UNITS.

NOT TO SCALE

ALL DIMENSIONS ARE IN MILLIMETRES UNLESS OTHERWISE NOTED

PRECAST CONCRETE PIER BARRIER
810 mm - CPB-E

SP941-02.01.06

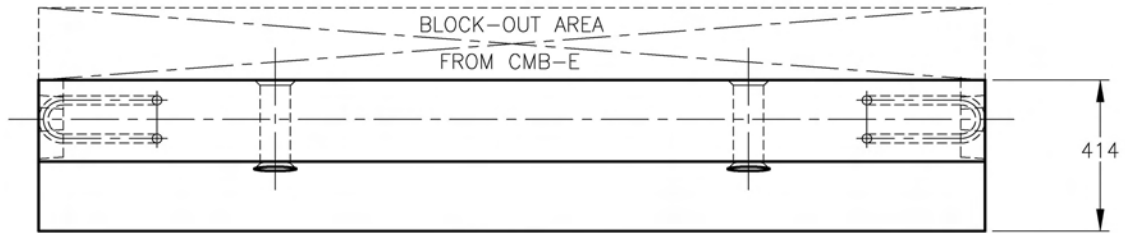

PLAN

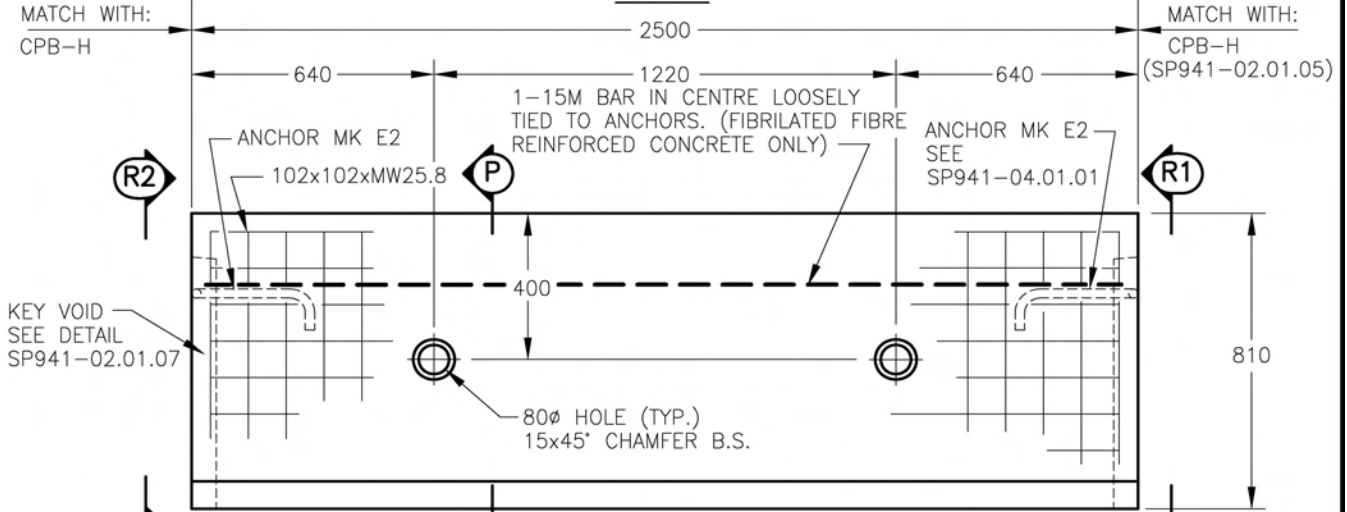

ELEVATION

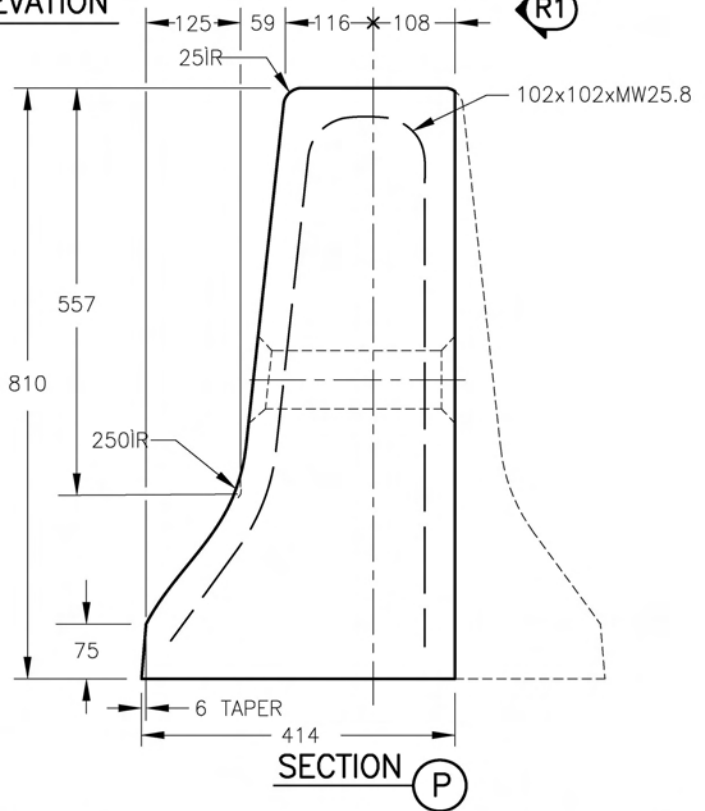

SECTION P

NOTES:

1. FOR VIEW (R1) & (R2) SEE SP941-02.01.07.
2. FOR GENERAL NOTES SEE SP941-01.02.01
3. SEE DRAWING SP941-02.01.05 FOR DETAILS OF HOOK UNIT.
4. THESE UNITS ARE INTENDED TO BE USED AGAINST BRIDGE SUPPORT STRUCTURES AND SIMILAR WALLS.
5. IT IS INTENDED THAT EXISTING CMB MOLDS WILL BE ADAPTED TO PRODUCE THESE CPB UNITS.

NOT TO SCALE

ALL DIMENSIONS ARE IN MILLIMETRES UNLESS OTHERWISE NOTED

PRECAST CONCRETE PIER BARRIER
810 mm – CPB-H & CPB-E DETAILS

SP941-02.01.07

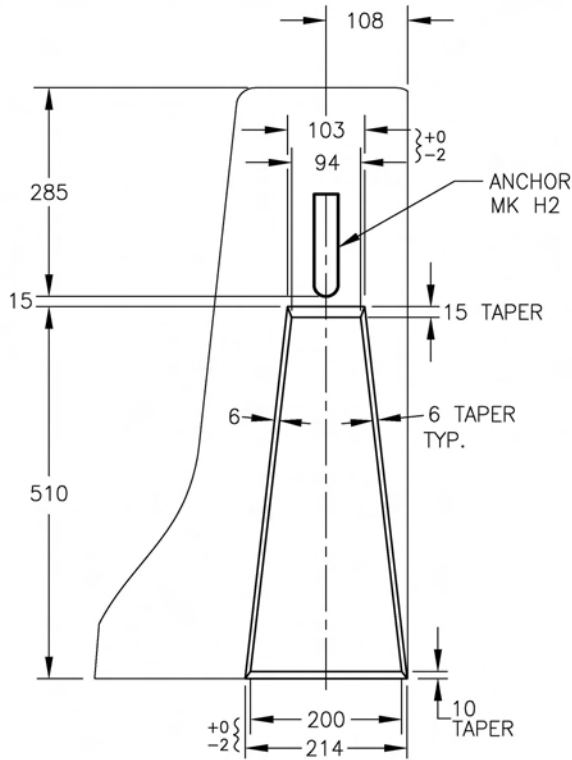

VIEW (HOOK UNIT) Q1 AS SHOWN
VIEW Q2 OPPOSITE HAND

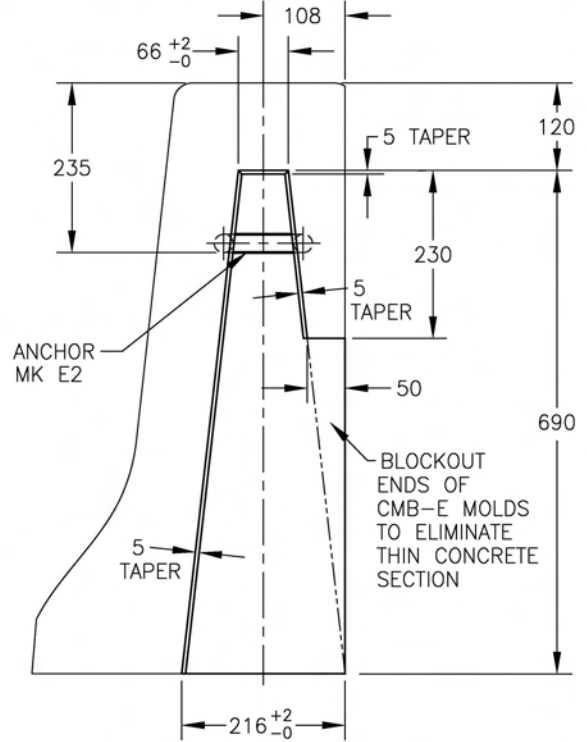

VIEW (EYE UNIT) R1 AS SHOWN
VIEW R2 OPPOSITE HAND

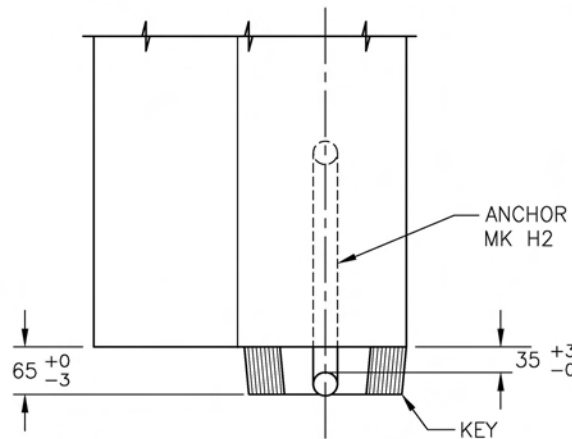

PLAN - END - HOOK UNIT

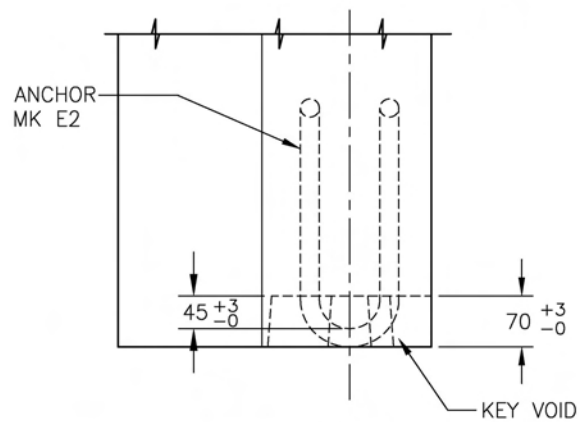

PLAN - END - EYE UNIT

NOTES:

1. FOR LOCATION OF VIEW **Q1** & **Q2** SEE SP941-02.01.05.
2. FOR LOCATION OF VIEW **R1** & **R2** SEE SP941-02.01.06.
3. FOR GENERAL NOTES SEE SP941-01.02.01
4. FOR DETAILS OF ANCHORS SEE SP941-04.01.01.

NOT TO SCALE

ALL DIMENSIONS ARE IN MILLIMETRES UNLESS OTHERWISE NOTED

PRECAST CRB-H
MODIFICATIONS FOR TIGHT CURVATURE INSTALLATION

SP941-02.01.08

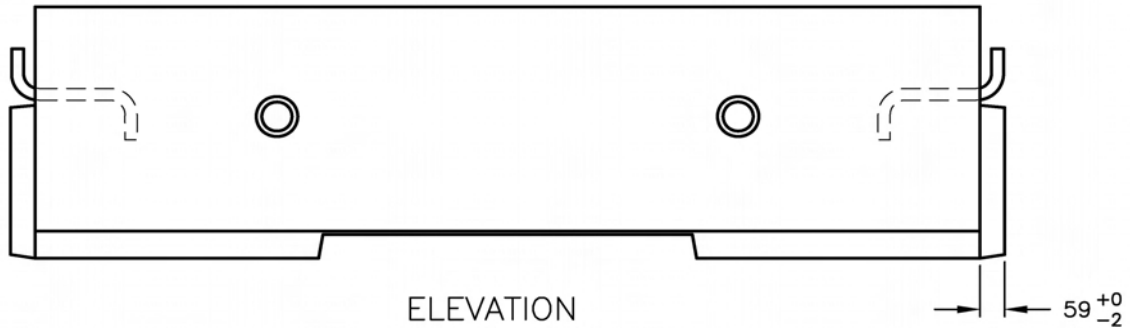

NOTES:

1. THIS DRAWING MUST BE READ WITH CRB DRAWINGS SP941-01.02.01 TO 941-01.02.04 FOR FULL DETAILS OF UNITS.
2. IT IS INTENDED THAT EXISTING CRB MOLDS BE ADAPTED TO DIMENSIONS NOTED ON THIS DRAWING TO PRODUCE UNITS CAPABLE OF BEING PLACED TO A MINIMUM CURVE RADIUS OF APPROXIMATELY 17 m.
3. ALL DIMENSIONS ARE IN mm.
4. ALL TOLERANCES AS PER CRB UNIT DRAWINGS.
5. THIS MODIFIED UNIT IS INTENDED TO BE USED ON TIGHT CURVATURE AT INTERSECTIONS ONLY.

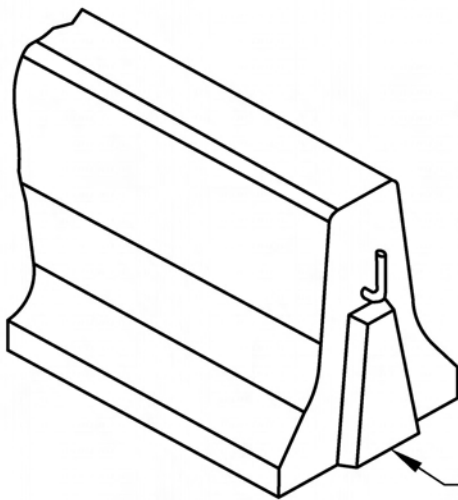

HOOK KEY MADE SMALLER BY USE OF 6 mm PLATE INSERT, ON BOTH KEY ENDS, AND 3 mm PLATE INSERTS ON BOTH SIDES OF KEYS DURING CASTING.

NOT TO SCALE

ALL DIMENSIONS ARE IN MILLIMETRES UNLESS OTHERWISE NOTED

PRECAST CRB-E
MODIFICATIONS FOR TIGHT CURVATURE INSTALLATION

SP941-02.01.09



ELEVATION

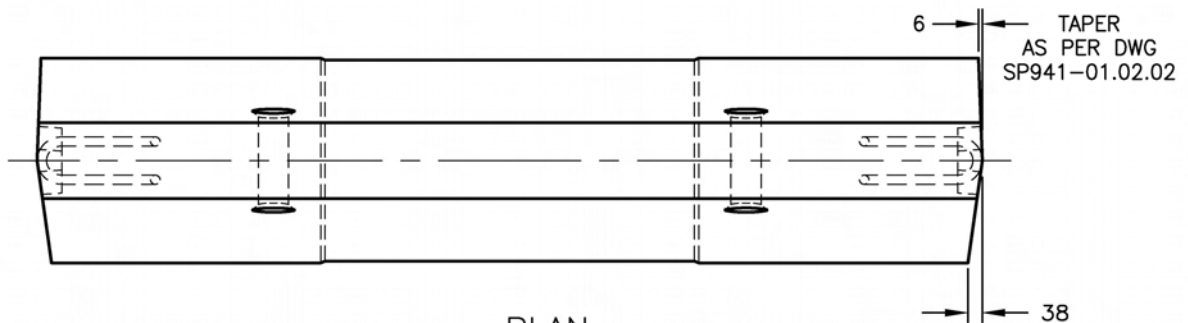

PLAN

NOTES:

1. THIS DRAWING MUST BE READ WITH CRB DRAWINGS SP941-01.02.01 TO 941-01.02.04 FOR FULL DETAILS OF UNITS.
2. IT IS INTENDED THAT EXISTING CRB MOLDS BE ADAPTED TO DIMENSIONS NOTED ON THIS DRAWING TO PRODUCE UNITS CAPABLE OF BEING PLACED TO A MINIMUM CURVE RADIUS OF APPROXIMATELY 17 m.
3. ALL DIMENSIONS ARE IN mm.
4. ALL TOLERANCES AS PER CRB UNIT DRAWINGS.
5. THIS MODIFIED UNIT IS INTENDED TO BE USED ON TIGHT CURVATURE AT INTERSECTIONS ONLY.

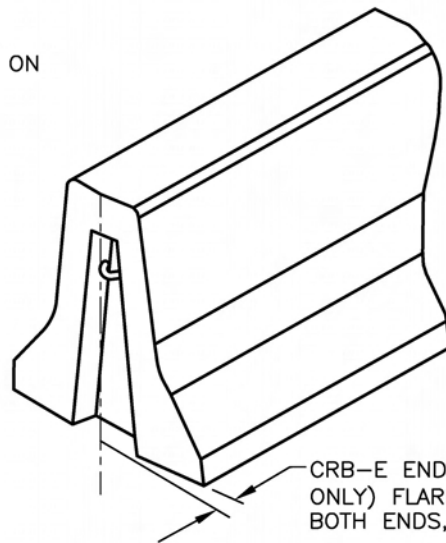

CRB-E END (ONE SIDE ONLY) FLARED 38 mm, BOTH ENDS, DURING CASTING

NOT TO SCALE

ALL DIMENSIONS ARE IN MILLIMETRES UNLESS OTHERWISE NOTED

PRECAST CONCRETE TRANSITION BARRIER
690 mm TO 460 mm – CTB-1E

SP941-03.01.01

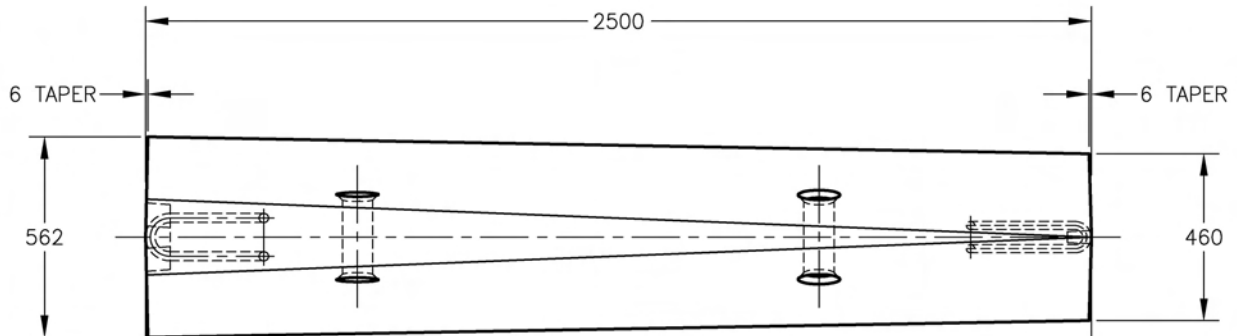

PLAN

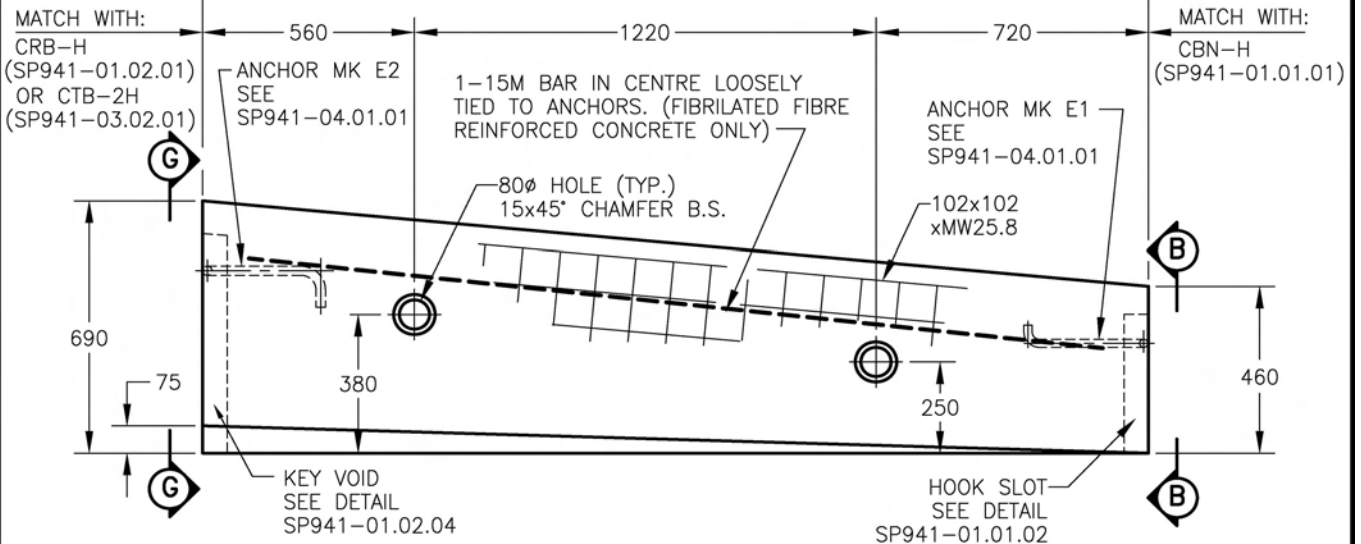

ELEVATION

NOTES:

1. FOR VIEW **(B)** SEE SP941-01.01.02. FOR VIEW **(G)** SEE SP941-01.02.04.
2. FOR GENERAL NOTES SEE SP941-01.02.01.
3. SEE DRAWINGS SP941-01.01.01 AND SP941-01.01.02 FOR DETAILS OF 460 mm UNIT AND BULLNOSE. SEE DRAWING SP941-01.02.01 FOR DETAILS OF 690 mm HOOK UNIT OR SP941-03.02.01 FOR DETAILS OF 810 TO 690 TRANSITION UNIT.

NOT TO SCALE

ALL DIMENSIONS ARE IN MILLIMETRES UNLESS OTHERWISE NOTED

PRECAST CONCRETE TRANSITION BARRIER
810 mm TO 690 mm – CTB-2H

SP941-03.02.01

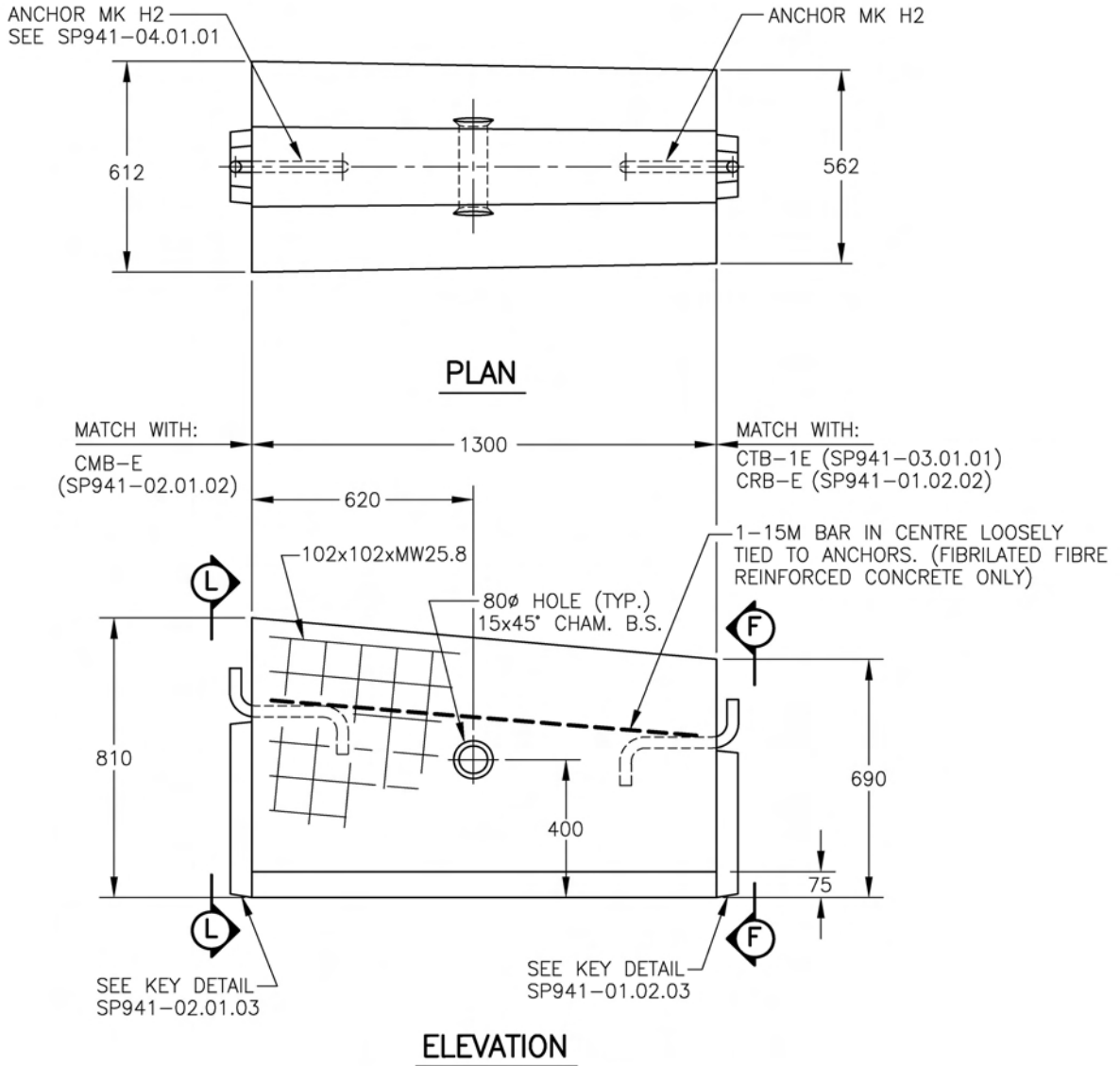

NOTES:

1. FOR VIEW (F) SEE SP941-01.02.03.
FOR VIEW (L) SEE SP941-02.01.03.
2. FOR GENERAL NOTES SEE SP941-01.02.01.
3. SEE DRAWING SP941-02.01.02 FOR DETAILS OF 810 mm EYE UNIT.
SEE DRAWING SP941-01.02.02 FOR DETAILS OF 690 mm EYE UNIT
OR SP941-03.01.01 FOR DETAILS OF 690 TO 460 TRANSITION UNIT.

NOT TO SCALE

ALL DIMENSIONS ARE IN MILLIMETRES UNLESS OTHERWISE NOTED

PRECAST CONCRETE TRANSITION BARRIER
686 mm TO 690 mm – CTB-3H

SP941-03.03.01

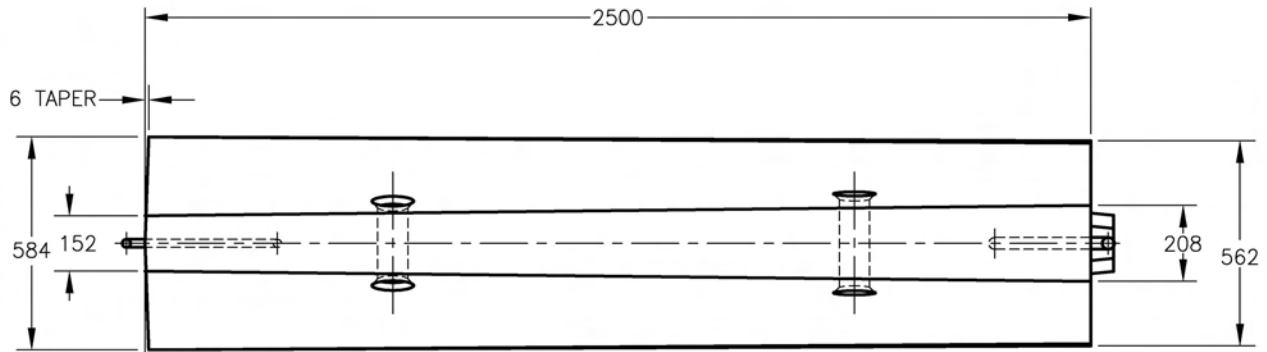

PLAN

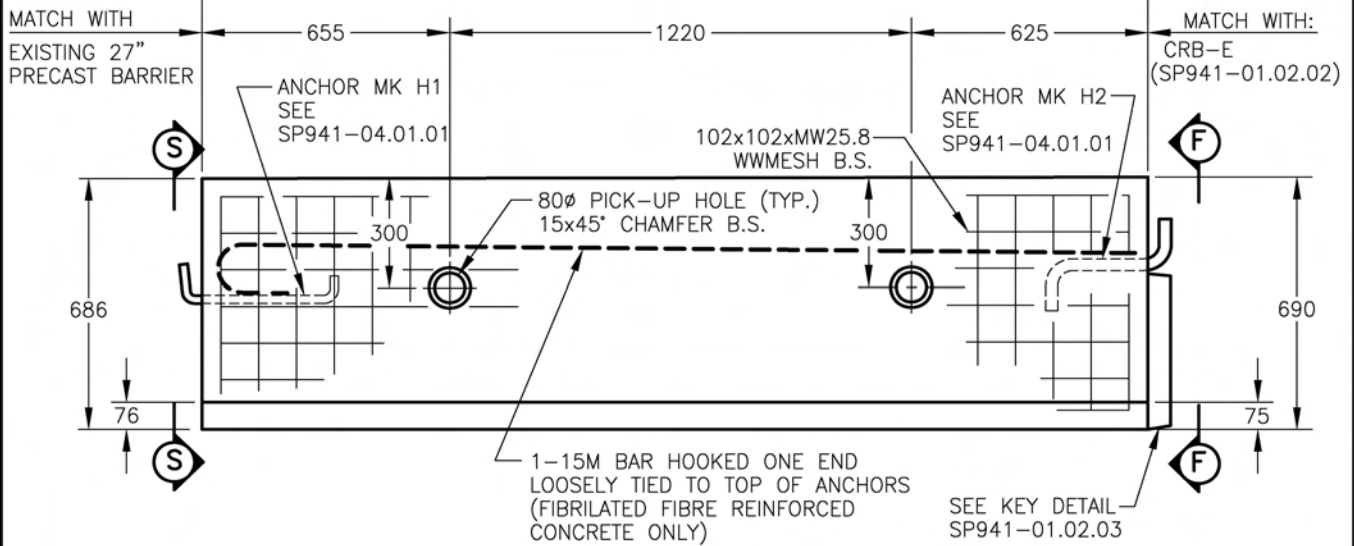

ELEVATION

NOTES:

1. FOR VIEW (F) SEE SP941-01.02.03. FOR VIEW (S) SEE SP941-03.03.02
2. FOR GENERAL NOTES SEE SP941-01.02.01
3. SEE DRAWING SP941-01.02.02 FOR DETAILS OF 690 mm EYE UNIT.
4. THIS UNIT TO BE USED WITH EXISTING 27" BARRIER. 27" BARRIERS ARE NO LONGER USED IN NEW INSTALLATIONS

NOT TO SCALE

ALL DIMENSIONS ARE IN MILLIMETRES UNLESS OTHERWISE NOTED

PRECAST CONCRETE TRANSITION BARRIER
686 mm TO 690 mm – CTB-3H DETAILS

SP941-03.03.02

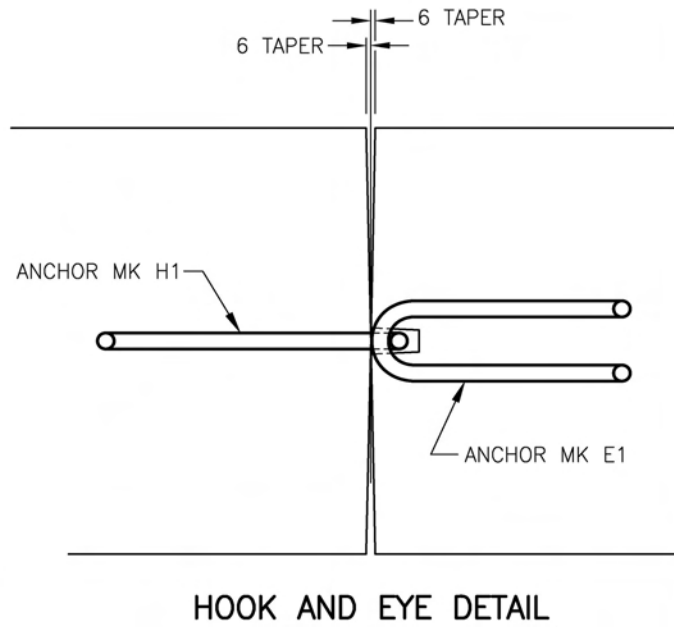
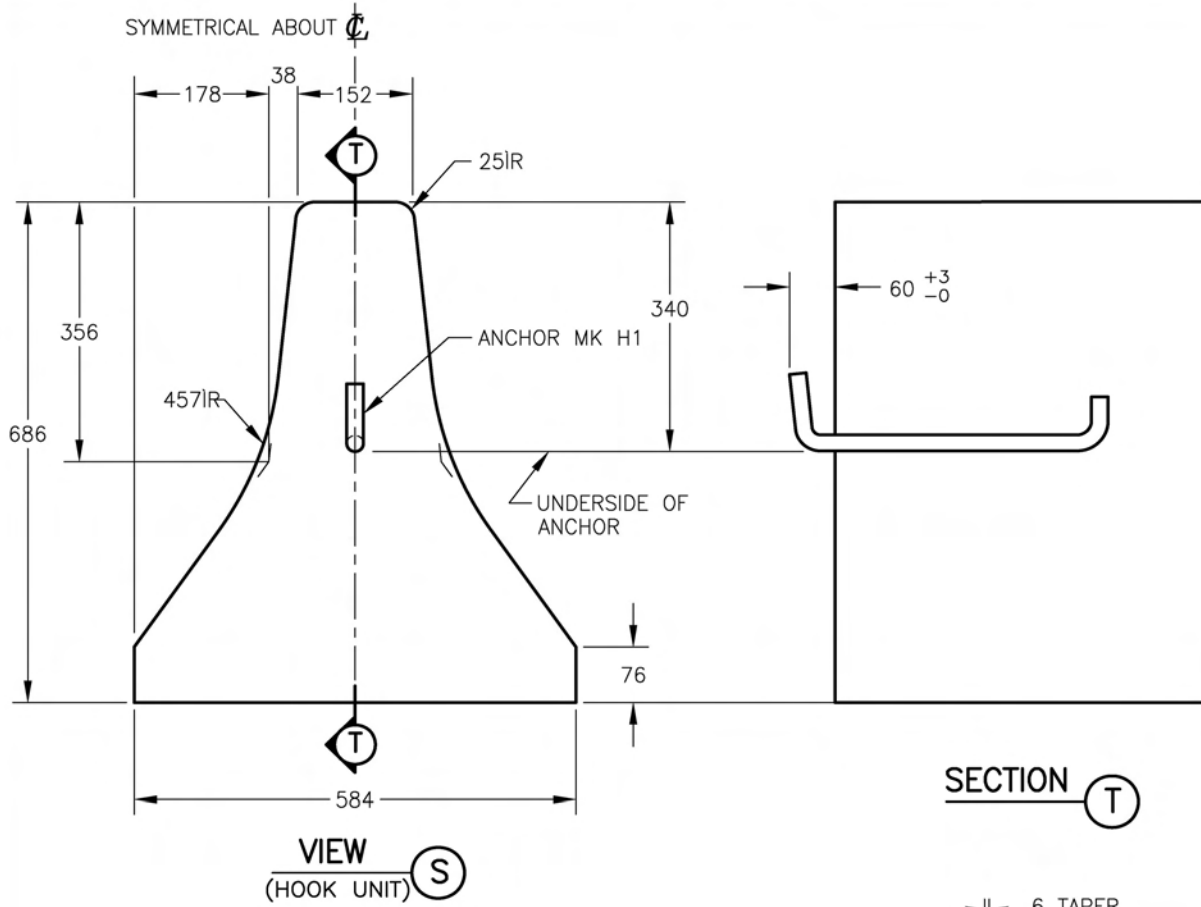

NOTES:

1. FOR LOCATION OF VIEW S SEE SP941-03.03.01
2. FOR GENERAL NOTES SEE SP941-01.02.01
3. FOR DETAILS OF ANCHORS SEE SP941-04.01.01.

NOT TO SCALE

ALL DIMENSIONS ARE IN MILLIMETRES UNLESS OTHERWISE NOTED

PRECAST CONCRETE TRANSITION BARRIER 686 mm TO 690 mm – CTB-3E+H	SP941-03.03.03
--	-----------------------

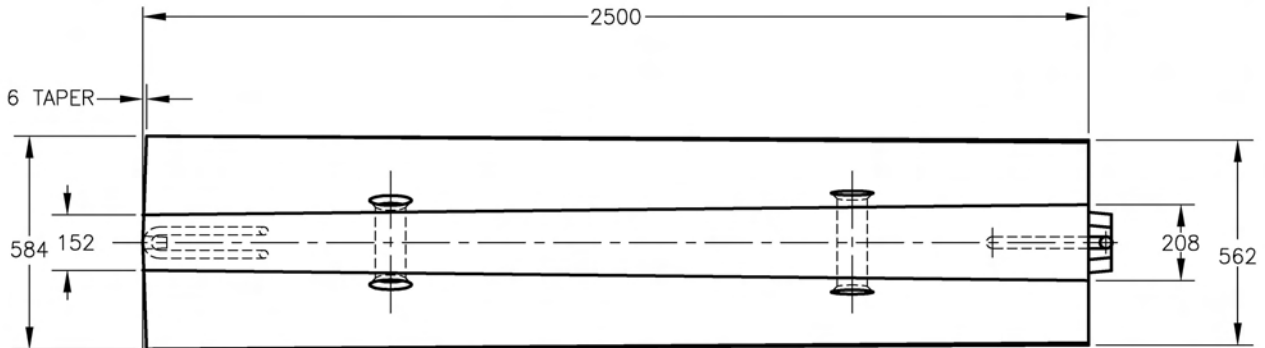

PLAN

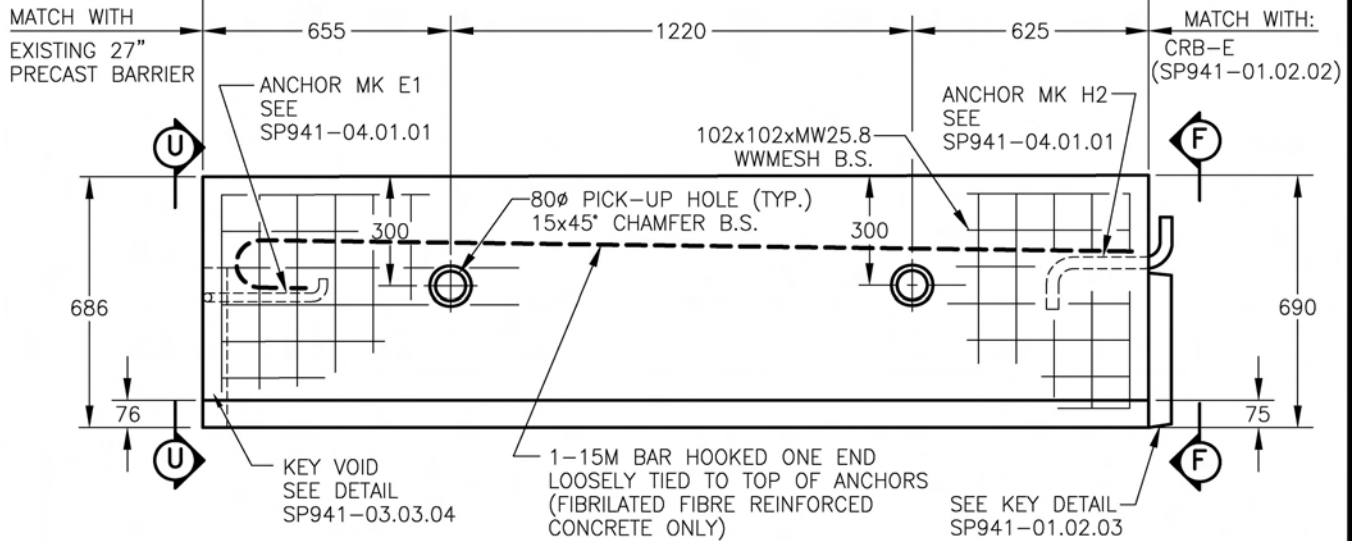

ELEVATION

NOTES:

1. FOR VIEW (F) SEE SP941-01.02.03.. FOR VIEW (U) SEE SP941-03.03.04
2. FOR GENERAL NOTES SEE SP941-01.02.01
3. SEE DRAWING SP941-01.02.01 FOR DETAILS OF 690 mm HOOK UNIT.
4. THIS UNIT TO BE USED WITH EXISTING 27" BARRIER. 27" BARRIERS ARE NO LONGER USED IN NEW INSTALLATIONS

NOT TO SCALE

ALL DIMENSIONS ARE IN MILLIMETRES UNLESS OTHERWISE NOTED

PRECAST CONCRETE TRANSITION BARRIER
686 mm TO 690 mm – CTB-3E+H DETAILS

SP941-03.03.04

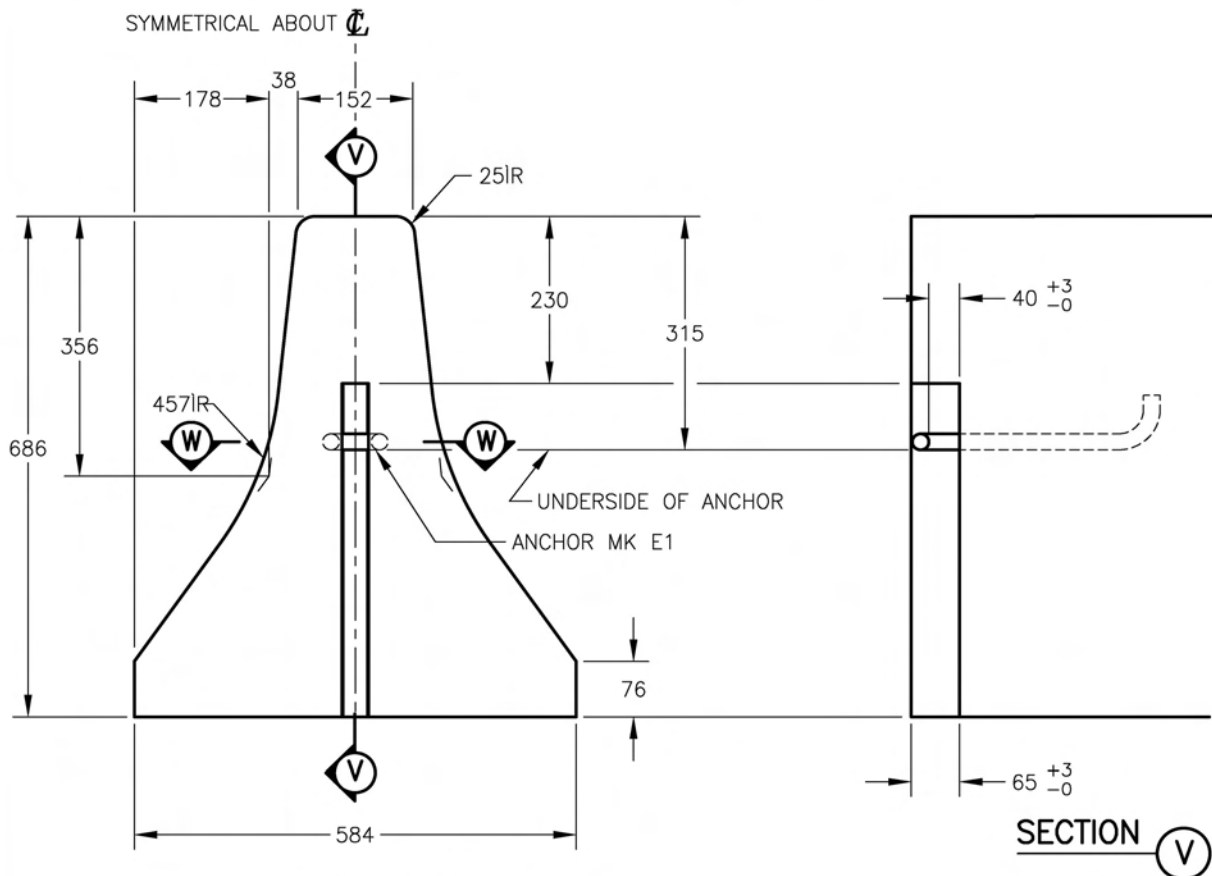

VIEW (EYE AND HOOK UNIT) U

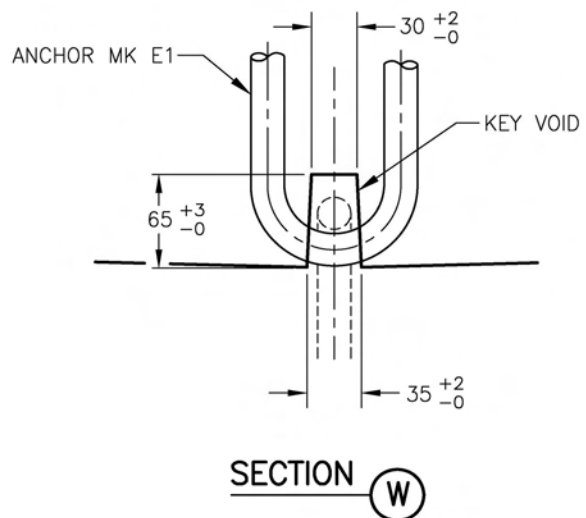

SECTION W

NOTES:

1. FOR LOCATION OF VIEW U SEE SP941-03.03.03.
2. FOR GENERAL NOTES SEE SP941-01.02.01
3. FOR DETAILS OF ANCHORS SEE SP941-04.01.01.

NOT TO SCALE

ALL DIMENSIONS ARE IN MILLIMETRES UNLESS OTHERWISE NOTED

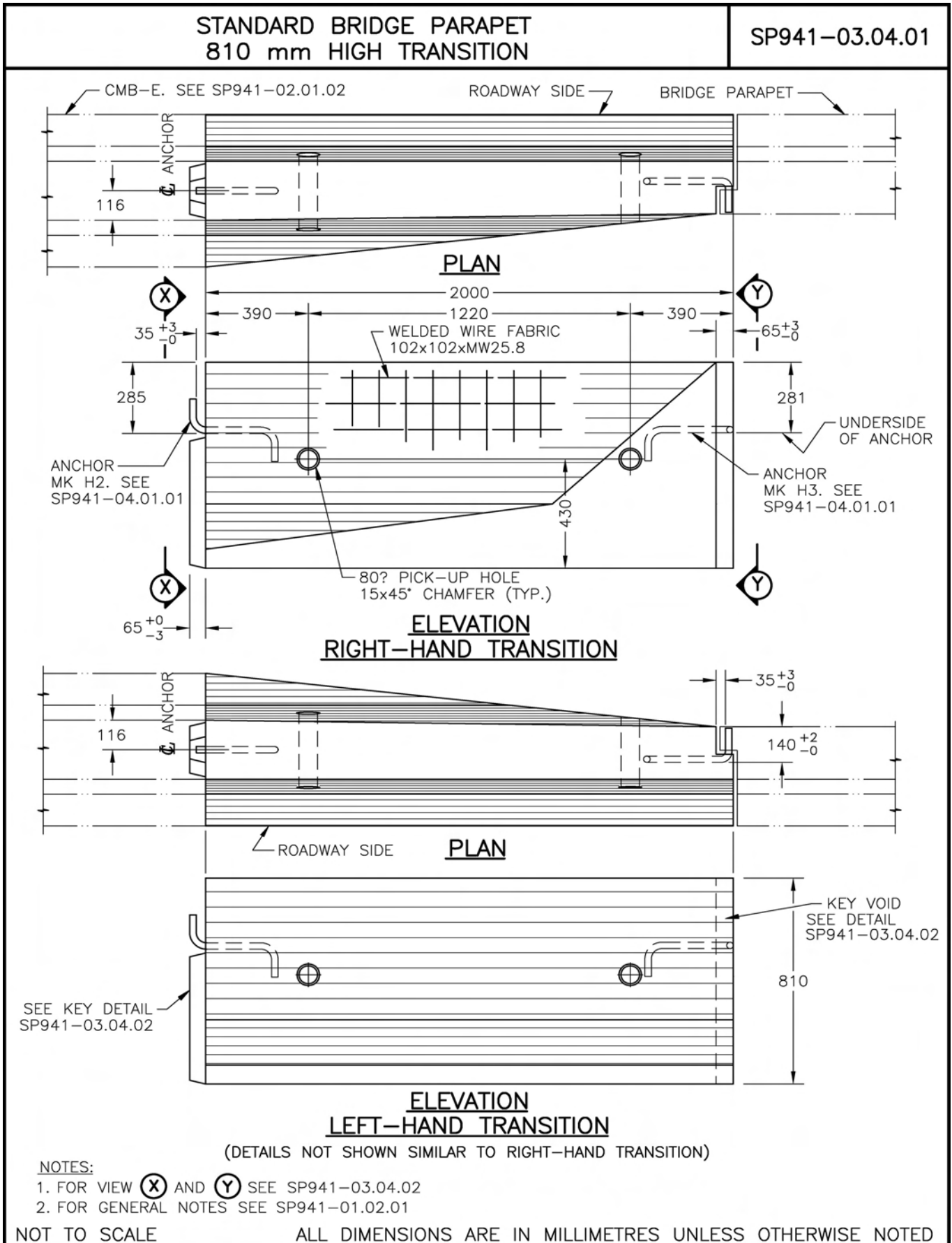

STANDARD BRIDGE PARAPET
810 mm HIGH TRANSITION – DETAILS

SP941-03.04.02

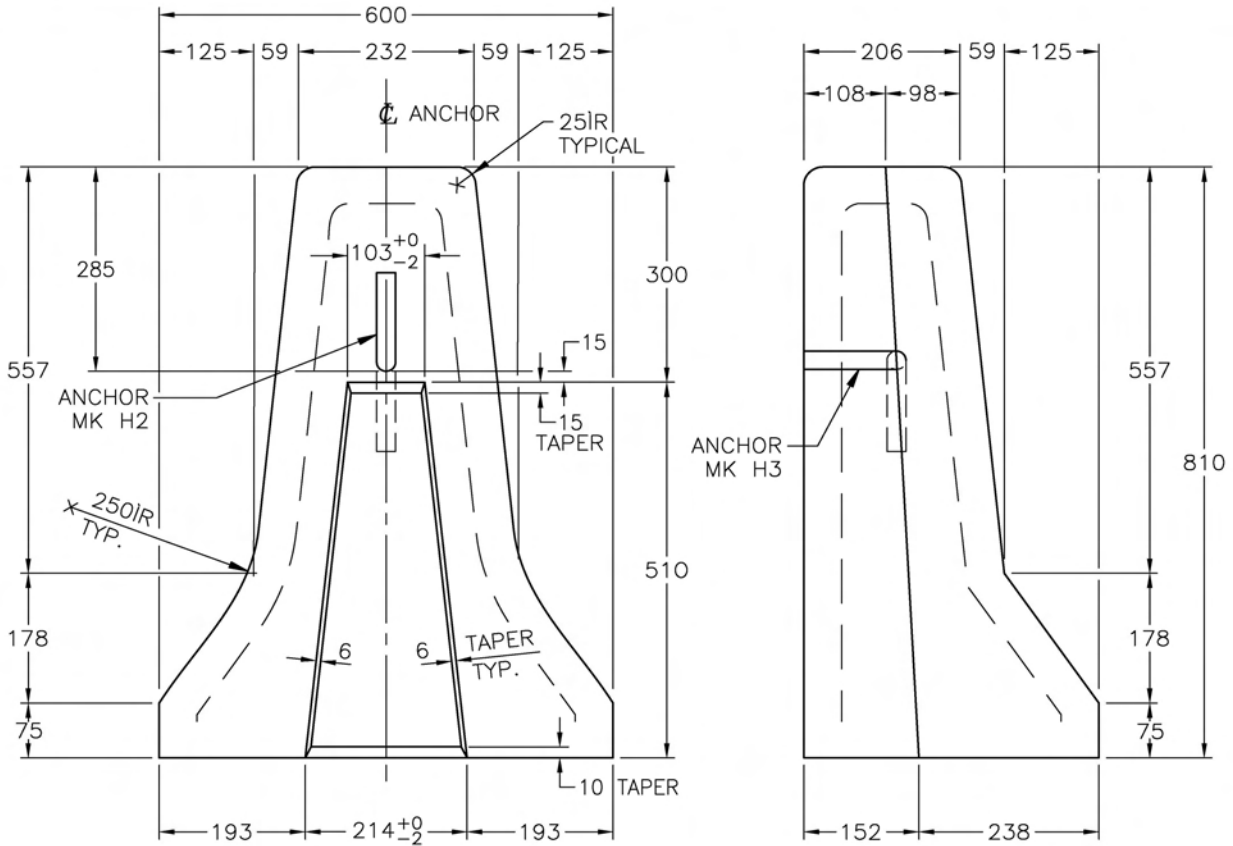

VIEW (X)

RIGHT HAND TRANSITION SHOWN
LEFT HAND TRANSITION SIMILAR

VIEW (Y)

RIGHT HAND TRANSITION SHOWN
LEFT HAND TRANSITION OPP. HAND

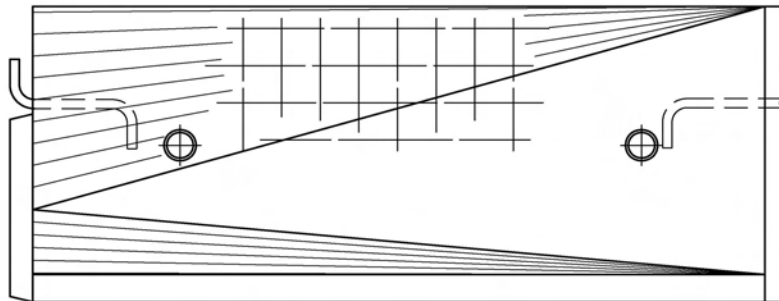

ACCEPTABLE ALTERNATE SIDE CONFIGURATION

RIGHT HAND TRANSITION ELEVATION SHOWN
LEFT HAND TRANSITION ELEVATION OPPOSITE HAND

NOTES:

1. FOR LOCATION OF VIEW (X) AND (Y) SEE SP941-03.04.01
2. FOR GENERAL NOTES SEE SP941-01.02.01

NOT TO SCALE

ALL DIMENSIONS ARE IN MILLIMETRES UNLESS OTHERWISE NOTED

NO POST BARRIER ANCHORING HARDWARE

SP941-04.01.01

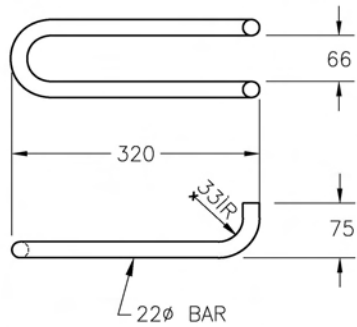

ANCHOR MK E1

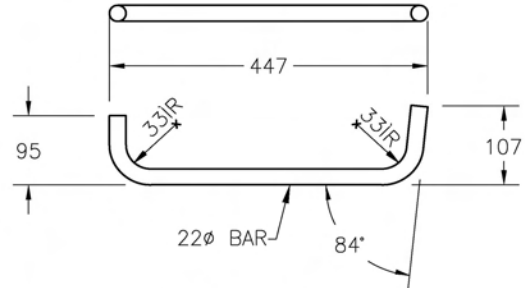

ANCHOR MK H1

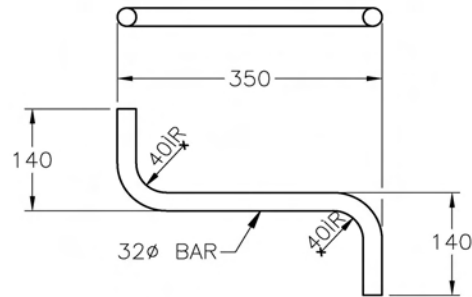

ANCHOR MK H2

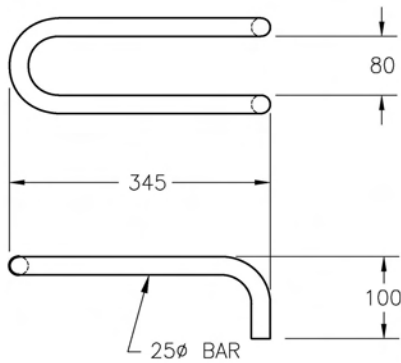

ANCHOR MK E2

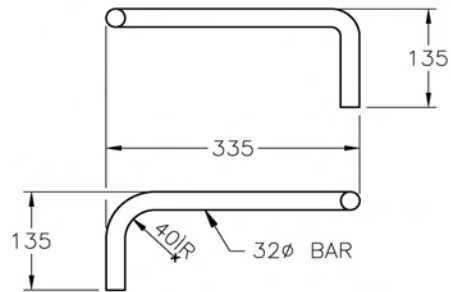

ANCHOR MK H3

NOTES:

1. STEEL FOR ANCHORS TO CONFORM TO CSA SPECIFICATION CAN3-G40.21M.
2. PRIOR TO DELIVERY, EXPOSED SURFACES OF CONNECTIONS SHALL BE PREPARED FOR AND GIVEN A HEAVY APPLICATION OF A CORROSION RESISTANT COATING.

NOT TO SCALE

ALL DIMENSIONS ARE IN MILLIMETRES UNLESS OTHERWISE NOTED

PRECAST CONCRETE ROADSIDE AND MEDIAN BARRIERS
SHEAR KEY VOID DETAILS

SP941-04.02.01

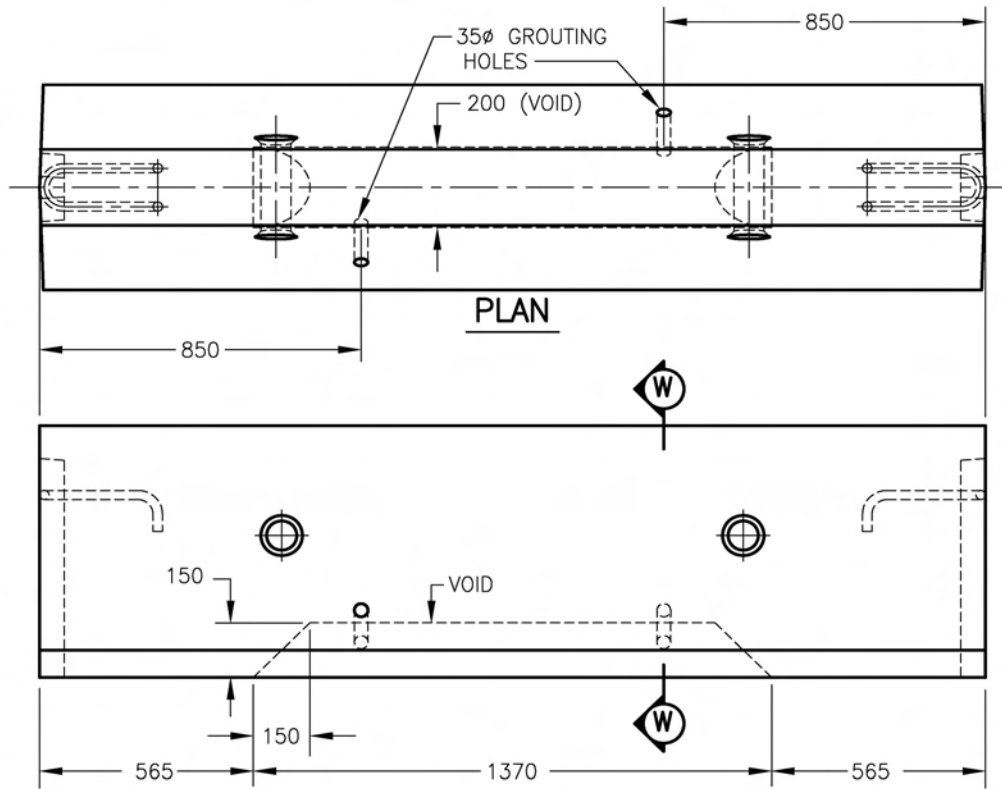

ELEVATION

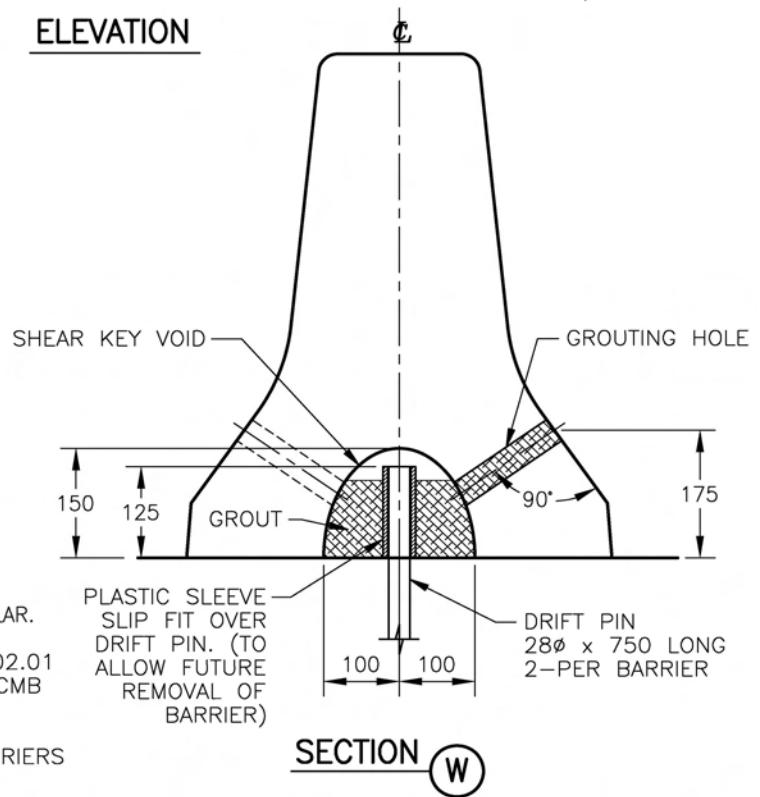

SECTION W

NOTES:

1. 690 HIGH CRB AS SHOWN. 810 HIGH CMB SIMILAR.
2. FOR DETAILS OF 690 CRB SEE SP941-01.02.01 & SP941-01.02.02. FOR DETAILS OF 810 CMB SEE SP941-02.01.01 & SP941-02.01.02.
3. DRAINAGE SLOTS ARE NOT ALLOWED IN BARRIERS WHEN SHEAR KEYS ARE REQUIRED.

NOT TO SCALE

ALL DIMENSIONS ARE IN MILLIMETRES UNLESS OTHERWISE NOTED

SECTION 951

ASPHALT AND PAVING MATERIALS FOR HIGHWAY USE

951.01 Scope

a) This Section describes the requirements for the different types and grades of asphalt and paving materials to be supplied for highway use.

b) The materials so described are generally classified as follows:

- Asphalt Cements
- Cutback Asphalts
- Asphalt Emulsions
- Tall Oil Pitch
- Emulsified Products

951.02 Quality Control Requirements

951.02.01 Quality Control System

a) The supplier shall develop a proven quality control system in accordance with the provisions of this Specification and the Special Provisions. The system shall ensure that adequate inspection coverage is maintained throughout the entire process of manufacture and shipping. All supplies processed or manufactured within the supplier's plant or procured from any other source shall receive sufficient inspection to ensure conformance to contractual requirements. Evidence of such inspection shall be available to the authorized inspector of the Ministry prior to delivery under a BC Government Purchase Order.

b) Supplies not conforming to contractual requirements shall not be offered for highway use until the deviations have been authorized by the requisitioning Ministry Representative.

c) The Ministry reserves the right to maintain surveillance over the supplier's quality control system to ensure conformance to the requirements of this Specification.

d) It shall be a responsibility of the manufacturer and supplier to ensure that all materials supplied to the Ministry satisfy the related Environmental and Health and Safety Regulations.

951.02.02 Quality Control Procedure – The supplier may be required to furnish the Ministry Representative with an outline of the quality control procedures detailing the method of implementing the requirements of this Specification. This outline shall include the following operations:

- sampling and testing
- storage and handling
- shipping
- recording and reporting.

951.02.03 Technical Requirements – The supplier shall maintain quality control throughout the facility during the following phases of manufacture:

a) **Batching and Batch Analysis:** Each batch of product covered by this Specification shall be given a batch number, and sampled and tested in accordance with the applicable Specification.

The batch analysis must show the Specification requirements for the product tested, test method employed, and the pertinent test results, as listed on Appendix A.

b) Certified batch analysis shall be dispatched to the field representative of the requisitioning Ministry Representative with the first load of material delivered. Provided the batch from which shipments are drawn remains the same and provided that the batch number is shown on the Bill of Lading, no further batch analysis will be required for subsequent remaining shipments. If, during the course of delivery, it is necessary to draw material from a different batch or batches of product, the analysis of the replacement batch shall be sent out with the first load of material from each and every replacement batch.

c) Product discharged directly into tank cars or tank trucks from "in line blending" facilities will be sampled as required to ensure uniformity and satisfy quality requirements.

951.03 Sampling and Testing

a) The supplier shall retain adequate sampling equipment, employ satisfactory sampling procedures, and maintain sampling program and records. Representative samples from filled shipping containers will be examined to ensure quality.

b) Test methods for asphalt and paving materials shall conform to the ASTM standard test, or, where there is no corresponding ASTM test, to the standard British Columbia Ministry of Transportation (BCH) tests, listed in Table 951-A, supplemented by such special tests as may be described elsewhere to cover special or experimental type materials.

c) On request, suppliers shall provide samples of the product to be supplied in such reasonable quantities (not less than 4 ℓ) as may be required for independent testing purposes.

951.04 Storage and Handling

a) Adequate bulk storage tanks shall be provided to ensure continuity of supply, uniformity of product, satisfactory temperature control, or to satisfy any other special requirements for which storage must be provided.

b) Adequate records shall be kept to provide the Ministry Representative with evidence that incoming products meet

the quality requirements and that the products were properly handled during storage and shipping. These records shall also show the amounts and destination of all shipments made to the Ministry.

TABLE 951-A TEST METHODS

TITLE OF TEST	TEST DESIGNATION	
	B.C.H.	ASTM
Penetration		D 5
Absolute Viscosity of Asphalts		D 2171
Kinematic Viscosity of Asphalts		D 2170
Effect of Heat and Air on Asphalt		D 1754
Distillation of Cutback Asphalt		D 402
Residue of 100 Penetration		D 243
Relative Density of Asphalt Cement and Cutback Asphalt		D 70
Ductility		D 113
Float Test		D 139
Flash Point by Tag Open Cup		D 1310
Flash Point by Cleveland Open Cup		D 92
Solubility in Trichloroethylene		D 2042
Water in Asphalt		D 95
Softening Point in Ethylene Glycol		D 2398
Saybolt Furol Viscosity		D 88
Testing Emulsified Asphalts		D 244
Testing High Float Asphalts	IV – 2	

TABLE 951-B VISCOSITY REQUIREMENTS FOR SHIPMENT DELIVERY TEMPERATURE

CLASS OF MATERIAL	KINEMATIC VISCOSITY, mm ² /s
Cutback Asphalt for Surface Spraying	100 – 200
Cutback Asphalt and Asphalt Cement for Plant Mixing	100 – 500
Tall Oil Pitch	20 – 40

951.05 Ordering and Accounting for Materials

a) A Purchase Order will be issued by the Purchasing Commission.

b) Each serially numbered Purchase Order will name the highway official or Contractor (hereafter referred to as the Consignee) to whom the asphalt and paving materials are to be delivered, the official to whom invoices shall be submitted and the f.o.b. points of delivery.

c) If, after an order has been placed, the Consignee should arrange for a material supplier to ship asphalt by an alternative and less economical means than the one specified, in order to satisfy the Consignee's method of operation, the supplier shall be responsible for collecting directly from the Consignee such extra charges that may arise and shall have no claim against the Ministry by reason of such change.

d) In order to expedite ordering and shipment, the supplier shall, immediately upon receipt of a Purchase Order for asphalt and paving materials, forward to the highway official named in the Purchase Order three copies of an information sheet giving the names, telephone numbers and addresses of the shipping officers who will be handling shipments of material under the Purchase Order.

The information sheet shall also detail normal delivery time to be expected and the railway schedules which will be used to effect shipments of asphalt and paving materials under the order.

e) Where shipments of asphalt and paving materials are made by rail tank car, the supplier shall notify both the Consignee and the highway official by telegram of each and every shipment, stating the tank car number, type of product, quantity loaded (at 15°C), time and date shipped, bill of lading date and freight train schedule, if available.

f) Every bill of lading must show:

- Purchase Order number
- Carrier number and description
- Shipping destination (both project and delivery point)
- Type of product
- Batch number
- Mass
- Relative density at 15°C
- Time out at refinery or plant
- Time order phoned in
- Requested time of delivery.

g) In order to avoid delays in payments, two copies of the bill of lading shall be left at the delivery point with the requisitioning Ministry Representative, who in turn will sign

one copy and mail it to Ministry Headquarters immediately. The supplier shall mail the invoices, in triplicate, as directed on the purchase order.

951.06 Delivery of Asphalt and Paving Materials

951.06.01 Expediting

a) The supplier of the asphalt and paving materials shall be responsible for the proper and prompt delivery of asphalt and paving materials in good condition and at correct temperature to the specified delivery point. The supplier shall ensure that the Consignee shall suffer no loss of production.

b) Asphalt and paving materials may be shipped from the supplier's refinery or plant by rail tankcar, motor transport truck, waterborne tanker or in steel drums, as may be specified.

Trucks shall be equipped with a submerged sampling valve system installed generally as shown on Drawing SP951-01 for each compartment in which asphalt material is to be carried out.

c) The Consignee shall make all arrangements with the supplier or the appointed carrier for the scheduling of deliveries.

Advance notice shall reach the appointed shipping officer:

- For tank truck deliveries, 24 hours before dispatch of load, or
- For rail tank car deliveries, 72 hours before dispatch of a load, except that the period between 17:00 Saturday and 8:00 Monday shall not be included in the 72 hour notice time.

Notice of cancellation of shipments must reach the Supplier 4 hours before the dispatch time of a load.

The original order to ship or cancel may be given by telephone, but a confirmatory telegram telex, or facsimile must reach the Supplier's shipper 4 hours before the time for dispatch of a shipment or the telephone order may be considered to be cancelled. Cancellation shall also be confirmed by telegram before the dispatch time for a shipment. The cost of all telephone calls, telex or telegrams shall be to the account of the Consignee .

d) Delivery temperature of the shipment shall meet the viscosity requirement shown in Table 951-B.

e) Asphalt Emulsions and emulsified products contain water and become unstable, break and separate if frozen. Therefore, to retain the homogeneity of these materials, they shall be kept at temperatures above 5°C.

Note: In no case shall asphalt materials or Tall Oil Pitch be received at a viscosity outside the specified viscosity range.

951.06.02 Receiving

a) The Consignee shall supply all labour and equipment to remove asphalt and paving materials from tank trucks or tank cars, if pertinent.

b) The demurrage free unloading period for trucks hauling asphalt and paving materials to the job will be two hours.

c) Although reasonable efforts will be made to accept tank truck delivery of asphalt and paving material products at all times, no compensation will be made for demurrage on motor tank truck deliveries made between 22:00 and 06:00 of the local time at the delivery point.

d) When demurrage is incurred due to the Consignee method of operation, the driver will ensure that the time involved is countersigned by the Consignee. Delays caused by Ministry personnel will be countersigned by the Ministry Representative's alternate. The carrier will issue a claim notice (a signed bill of lading is acceptable as proper documentation) for all properly documented claims. The carrier shall notify the supplier within three weeks of the occurrence, and the supplier will invoice the Ministry directly.

951.06.03 Returned Products – Freight costs deriving from delivery to the Project and return of asphalt and paving material products to the refinery or plant are to be invoiced to the Ministry at the haul rates contracted between the supplier and the carrier for that particular project.

951.07 Asphalt Cement

Asphalt cements shall:

a) Be products prepared by the refining of petroleum oils.

b) Be homogeneous, free from water and shall not foam when heated to 175°C.

c) Conform to the requirements specified in Tables 951-C and 951-D.

The supplier shall forward a 4 ℓ sample of the product to the Ministry Representative.

NOTE: Values for penetration and viscosity are point values only. Intermediate values for Group A, B and C grades shall be obtained by interpolation between the tabulated values on a straight line basis. Minimum viscosity at 60°C for other penetrations within each group can be read from the corresponding straight line on Drawing SP951-04.

951.08 Cutback Asphalts

a) Cutback asphalts shall consist essentially of petroleum derivatives and shall be substantially free from water and other impurities.

b) Cutback asphalts shall be of the type and grade described in Tables 951-E through 951-H.

951.09 – 951.15 Not Used

951.16 Asphalt Emulsions – Asphalt materials in the form of aqueous emulsions shall be of:

SECTION 951

ASPHALT AND PAVING MATERIALS FOR HIGHWAY USE

- Anionic Type
- Cationic Type
- High Float Type

951.17 Anionic Type Emulsion for Road Purposes – Anionic type of emulsion requirements are as follows:

- The asphalt emulsion shall be homogeneous.
- It shall show no separation of asphalt after thorough mixing within 30 days (crack filler 20 days) after delivery provided separation has not been caused by freezing.
- The emulsion shall conform to the requirements listed in Table 951-I.

951.18 Cationic Type Emulsions for Road Purposes – Cationic type emulsions shall conform to the requirements listed in Table 951-J and shall be uniform throughout.

951.19 High Float Emulsified Asphalt – Storage stability – High float emulsified asphalt shall show no separation of asphalt within 30 days after delivery and shall be homogeneous after thorough mixing.

The emulsion shall conform to the requirements listed in Table 951-K.

951.20 Tall Oil Pitch (TOP) – Tall oil pitch, co-product of the pulp and paper industry is a residual fraction from the crude tall oil vacuum distillation process. It shall be a dark brown resinous and viscous material insoluble in water but

miscible with asphalt. TOP is typically used by the Ministry as an asphalt extender, recycling, and anti-stripping agent. Where required, TOP will be added to asphalt cement in a ratio defined by the mix design, usually between 5 – 10%. The composition and properties of TOP depends on the origin and type of trees from which it is derived and the extraction technology. Only TOP approved by the Ministry's New Product Standing Committee shall be permitted for use on Ministry paving projects.

The TOP shall conform to the requirements listed in Tables 951-L and 951-M.

951.21 Emulsified Products – Emulsified products consist of emulsified Tall Oil Pitch and proprietary asphalt based emulsions. The emulsified products are typically used by the Ministry, in paving operations, as prime coats and tack coats and replace organic solvent based cutback asphalts for environmental reasons. Only products approved by the Ministry's New Product Standing Committee shall be permitted for use on the Ministry paving projects. Each batch of the product delivered to the job site shall be accompanied by the written statement from the manufacturer or supplier confirming that the product formulation complies with the original, previously approved formulation. Emulsified Tall Oil Pitch and asphalt based emulsified products shall conform to the requirements listed in Tables 951-N and 951-O.

TABLE 951-C GRADES OF ASPHALT CEMENT

PENETRATION GRADE ASPHALT CEMENT	80 – 100		150 – 200		200 – 300		TEST METHOD ASTM
	Min	Max	Min	Max	Min	Max	
Requirements							
Penetration at 25°C 100 g and 5 s, 0.1 mm	80	100	150	200	200	300	D 5
Group A Group B Group C	Minimum viscosity values defining boundaries for groups A, B, & C are listed in Table 951-D and illustrated in Drawing SP951-04						
Flash Point, °C Cleveland Open Cup	230	---	220	---	175	---	D 92
Thin Film Oven Test % Loss in Mass	---	0.85	---	1.3	---	1.5	D 1754
Penetration of Residue at 25°C 100 g, 5 s, 0.1 mm, % of Original Penetration	55	---	50	---	45	---	After T.F.O.T.
Solubility in Trichloroethylene % by Mass	99.5	---	99.5	---	99.5	---	D 2042
Ductility, 25°C 5 cm/min, cm	100	---	100	---	---	---	D 113
Ductility, 15°C 5 cm/min, cm	---	---	---	---	100	---	

TABLE 951-D VISCOSITY AND PENETRATION VALUES DEFINING GROUP BOUNDARIES

Penetration 25°C	80	100	150	200	300	TEST METHOD – ASTM
						D 5
	Minimum Viscosity at 60°C					D 2171
Group A	150	115	70	50	31	
Group B	110	85	---	---	---	
Group C	75	55	---	---	---	

TABLE 951-E SLOW CURING CUTBACK ASPHALT

REQUIREMENTS	GRADE					
	SC – 70		SC – 250		SC – 3000	
	Min	Max	Min	Max	Min	Max
Flash Point °C	65	---	80	---	105	---
Kinematic Viscosity at 60°C, mm ² /s	70	140	250	500	3 000	6 000
Residue from Distillation to 360°C, volume % by difference	70	90	80	94	95	---
Distillation Residue, Kinematic Viscosity at 60°C, mm ² /s	400	7 000	800	10 000	4 000	35 000
ASPHALT RESIDUE:						
Residue of 100 Penetration, % by Mass	50	---	60	---	80	---
Ductility of 100 Penetration residue at 25°C, cm	100	---	100	---	100	---
Solubility in Trichloroethylene	99.0	---	99.0	---	99.0	---
Water, % by Mass or Volume	---	0.5	---	0.5	---	0.5

TABLE 951-F MEDIUM CURING CUTBACK ASPHALT

REQUIREMENTS	GRADE			
	MC – 30		MC – 250	
	Min.	Max.	Min.	Max.
Flash Point °C	38	---	65	---
Kinematic Viscosity at 60°C, mm ² /s	30	60	250	500
Distillation Test, % of Total Distillate to 360°C: to 225°C	---	25	---	10
Distillation Test, % of Total Distillate to 360°C: to 260°C	40	70	15	55
Distillation Test, % of Total Distillate to 360°C: to 315°C	75	93	60	87
Residue from Distillation to 360°C, volume % by difference	50	---	67	---
PROPERTIES OF RESIDUE FROM DISTILLATION:				
Penetration at 25°C, 100 g, 5 s, 0.1 mm	120	250	120	250
Ductility at 25°C, cm	100	---	100	---
Solubility in Trichloroethylene	99.0	---	99.0	---
Water, %	---	0.2	---	0.2

TABLE 951-G RAPID CURING CUTBACK ASPHALT

REQUIREMENTS	GRADE					
	RC – 30		RC – 70		RC – 250	
	Min	Max	Min	Max	Min	Max
Flash Point °C	---	---	---	---	27	---
Kinematic Viscosity at 60°C, mm ² /s	30	60	70	140	250	500
Distillation Test, % of Total Distillate to 360°C: to 190°C	15	---	10	---	---	---
Distillation Test, % of Total Distillate to 360°C: to 225°C	55	---	50	---	35	---
Distillation Test, % of Total Distillate to 360°C: to 260°C	75	---	70	---	60	---
Distillation Test, % of Total Distillate to 360°C: to 315°C	90	---	85	---	80	---
Residue from Distillation to 360°C, volume % by difference	50	---	55	---	65	---
TEST ON RESIDUE FROM DISTILLATION:						
Penetration at 25°C, 100 g, 5 s, 0.1 mm	80	120	80	120	80	120
Ductility at 25°C, cm	100	---	100	---	100	---
Solubility in Trichloroethylene, % by mass	99.0	---	99.0	---	99.0	---
Water, %	---	0.2	---	0.2	---	0.2

TABLE 951-H CUTBACK ASPHALT PRIMER RM20

REQUIREMENTS	Min.	Max.
Kinematic Viscosity at 60°C, mm ² /s	20	35
Distillation Test, % of Total Distillate to 360°C: to 190°C	---	60
Distillation Test, % of Total Distillate to 360°C: to 225°C	40	---
Distillation Test, % of Total Distillate to 360°C: to 260°C	70	---
Distillation Test, % of Total Distillate to 360°C: to 315°C	85	---
Residue from Distillation to 360°C, volume % by difference	50	---
TEST ON RESIDUE FROM DISTILLATION:		
Penetration at 25°C, 100 g, 5 s, 0.1 mm	80	200
Ductility at 25°C, cm	100	---
Solubility in Trichloroethylene	99.0	---
Water, %	---	0.2

TABLE 951-I REQUIREMENTS FOR ANIONIC TYPE EMULSIONS

REQUIREMENT	TYPE OF EMULSION									
	RS – 1		RS – 2		MS – 2		SS – 1		CRACK FILLER	
	Min	Max	Min	Max	Min	Max	Min	Max	Min	Max
Viscosity, Saybolt Furol: at 25°C	20	100	---	---	100	---	20	100	50	200
Viscosity, Saybolt Furol: at 50°C	---	---	75	300	---	---	---	---	---	---
Residue by Distillation, %	57	---	62	---	62	---	57	---	65	75
Settlement, 1 Day, %	---	1.5	---	1.5	---	1.5	---	1.5	---	1.5
Demulsibility: 50 mL of 0.1 N CaCl ₂ %	---	---	---	---	---	30	---	---	---	---
Demulsibility: 35 mL of 0.02 N CaCl ₂ %	60	---	60	---	---	---	---	---	30	---
Sieve Test, % Retained on 1 mm	---	0.10	---	0.10	---	0.10	---	0.10	---	0.10
Cement Mixing Test, %	---	---	---	---	---	---	---	2.0	---	---
TESTS ON RESIDUE:										
Penetration at 25°C, 100 g, 5 s	100	200	100	200	100	200	100	200	60	100
Solubility in Trichloroethylene %	97.5	---	97.5	---	97.5	---	97.5	---	97.5	---
Ductility at 25°C, cm	60	---	60	---	60	---	60	---	60	---

TABLE 951-J REQUIREMENTS FOR CATIONIC TYPE EMULSIONS

REQUIREMENT	TYPE OF EMULSION			
	CRS – 1K		CRS – 2K	
	Min	Max	Min	Max
Saybolt Furol Viscosity at 50°C	30	125	174	400
% Residue by Distillation	62	---	68	---
Settlement 1 Day, %	---	1.5	---	1.5
Sieve Test, % Retained on 1 mm Mesh	---	0.1	---	0.1
Oil Portion of Distillate, % of Total Volume	0	3	0	3
Particle Charge	POSITIVE		POSITIVE	
TESTS ON RESIDUE				
Penetration at 25°C, 100 g, 5 s	100	250	100	150
Solubility in Trichloroethylene %	97.5	---	97.5	---
Ductility at 25°C, cm	60	---	65	---

TABLE 951-K REQUIREMENTS FOR HIGH FLOAT EMULSIFIED ASPHALTS

REQUIREMENT	GRADE											
	HF-100S		HF-150S		HF-250S		HF-350S		HF-500M		HF-1000M	
	Min	Max	Min	Max	Min	Max	Min	Max	Min	Max	Min	Max
Residue by Distillation, % By Mass	62	---	62	---	62	---	65	---	65	---	65	---
Oil Distillate % By Volume	1	4	0.5	4	1	6	1.5	6	1	6	1	7
Saybolt Viscosity, Furol Seconds at 50°C	35	150	35	150	35	150	75	400	50	---	50	---
Sieve Test, % Retained on 1 mm Sieve	---	0.1	---	0.1	---	0.1	---	0.1	---	0.1	---	0.1
Coating Test %	90	---	90	---	90	---	---	---	---	---	---	---
Settlement 1 Day, % By Mass	---	1.5	---	1.5	---	1.5	---	1.5	---	1.5	---	1.5
Demulsibility: 50 mL 5.55 g/L CaCl ₂ , % By Mass	75	---	75	---	---	---	---	---	---	---	---	---
Workability @ 10°C	---	---	---	---	---	---	---	---	---	---	Pass	---
TEST ON RESIDUE												
Penetration at 25°C, 100 g, 5 s	*		**		**		**		---	---	---	---
Viscosity at 60°C, Pa·s	*		**		**		**		8	20	2	8
Float Test at 60°C, s	1200	---	1200	---	1200	---	1200	---	1200	---	1200	---
Solubility in Trichloroethylene, %	97.5	---	97.5	---	97.5	---	97.5	---	97.5	---	97.5	---

* See Drawing SP951-02

** See Drawing SP951-03

TABLE 951-L TALL OIL PITCH VISCOSITY AND PENETRATION DATA

REQUIREMENTS	Min.	Max.
Results on original sample		
Absolute Viscosity, 60°C, PaCs	1	2
Kinematic Viscosity, 135°C, mm ² /s	25	35
Penetration, 4°C/100g, 5 sec, 0.1 mm	150	250
Results after Thin Film Oven		
Loss in weight, %	---	0.65
Absolute Viscosity, 60°C, PaCs	---	3
Kinematic Viscosity, 135°C, mm ² /s	---	60
Penetration, 4°C, 100 g, 5 sec, 0.1 mm	75	---

TABLE 951-M TALL OIL PITCH DATA

REQUIREMENTS	Min.	Max.
Softening Point, °C (ASTM D 36)	---	35
Flash Point, Cleveland Open Cup, °C (ASTM D 92)	250	---
Fire Point, Cleveland Open Cup, °C (ASTM D 92)	275	---
Boiling Point, °C	320	---
Specific Gravity	0.94	0.98
Vapour Pressure, mm Hg	---	1
pH	3.75	4.25
Wood Extractive, %	98	---
Ash, % (ASTM D 803)	---	0.8
Moisture, % (ASTM D 803)	---	0.1
Fatty Acids, %	7	9
Resin Acids, %	5	7
Unsaponifiables, %	39	44
Neutrals, %	42	46
Acid Number	20	30

TABLE 951-N EMULSIFIED TALL OIL PITCH

REQUIREMENTS	Min.	Max.
Viscosity, SF, 25°C, s	10	30
Residue by Distillation, % by weight	40	---
Oil Distillate, % by volume	---	0.1
Settlement 24hrs, %	---	1.5
pH	6	8
Particle Charge	Negative	
Miscibility with Water	Pass	
Specific Gravity, 20°C	Approx. 1.0	
Boiling Point, °C	100	
Freezing Point, °C	0	
Vapour Pressure, mm Hg	20	
Odour and Appearance – distinctive resinous Odour, light yellow colour		
TEST ON RESIDUE – Shall conform to the requirements for Tall Oil Pitch listed in Table 951-L		

TABLE 951-O EMULSIFIED PRODUCTS

REQUIREMENTS	Min.	Max.
Viscosity, SF , 25°C, s	10	60
Residue by Distillation, % by weight	40	---
Oil Distillate, % by Volume	---	5
Settlement 24hrs, %	Pass	
Miscibility with Water	Pass	
TEST ON RESIDUE		
Penetration, 25°C, 100 g, 5 sec, 0.1 mm	40	200

SECTION 951 – APPENDIX A

The following data is required with the supplier's Quotation:

ASPHALT CEMENTS**Grade and Type (when required)****A.Original Asphalt**

- Density @ 15°C, kg/L
- Viscosity @ 135°C
- Viscosity @ 60°C
- Penetration @ 25°C, 100 g/5 s
- Solubility in Trichloroethylene
- Ductility @ 25°C
- Flash Point C.O.C.
- % Retained Penetration after T.F.O.T.
@ 25°C

B.Residue After T.F.O.T.

(when Type A required)

- Penetration @ 25°C
- Penetration @ 10°C
- Penetration @ 4°C

NOTE: Viscosity – Temperature chart also required for each batch.

CUTBACK ASPHALTS**A.Cutback Asphalts as Supplied**

- Flash Point, T.O.C. (C.O.C. above 79°C)
- Density @ 15°C, g/cm³
- Viscosity @ 60°C, mm²/s
- Distillate, % by volume of Total
 - Distillate to 360°C
 - Distillate to 190°C
 - Distillate to 225°C
 - Distillate to 260°C
 - Distillate to 315°C
- Residue from Distillation to 360°C
- Volume % by Difference

B.Properties of Residue

- Penetration @ 25°C
- Ductility @ 25°C
- Solubility in Trichloroethylene, %

C.Residue of 100 Penetration by Mass

- Ductility of 100 Penetration at 25°C, cm

EMULSIONS**A.Original Emulsion**

- Saybolt Furol Viscosity @ 25°C
- Saybolt Furol Viscosity @ 50°C
- % Residue by Distillation
- Settlement in 5 Days, %
- Oil Portion of Distillate
- % to Total Volume

B.Tests on Residue

- Float Test @ 60°C, s
- Penetration @ 25°C, 100 g/5 s
- Ductility @ 25°C

TRUCK TANK SAMPLING VALVE

SP951-01

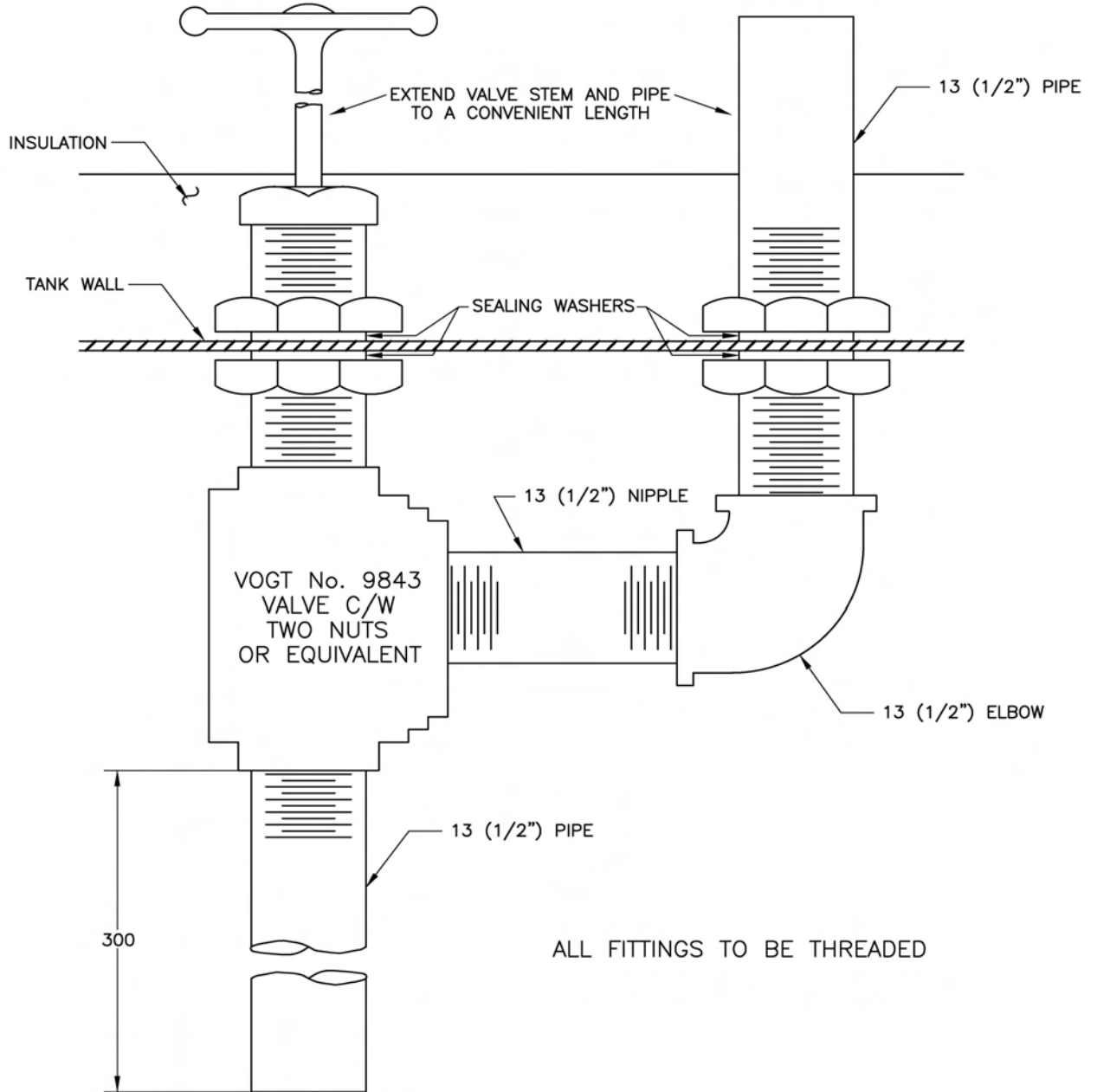

NOT TO SCALE

ALL DIMENSIONS ARE IN MILLIMETRES UNLESS OTHERWISE NOTED

VISCOSITY REQUIREMENTS FOR DISTILLATION RESIDUES FROM HIGH FLOAT EMULSIFIED ASPHALT, HF-100S

SP951-02

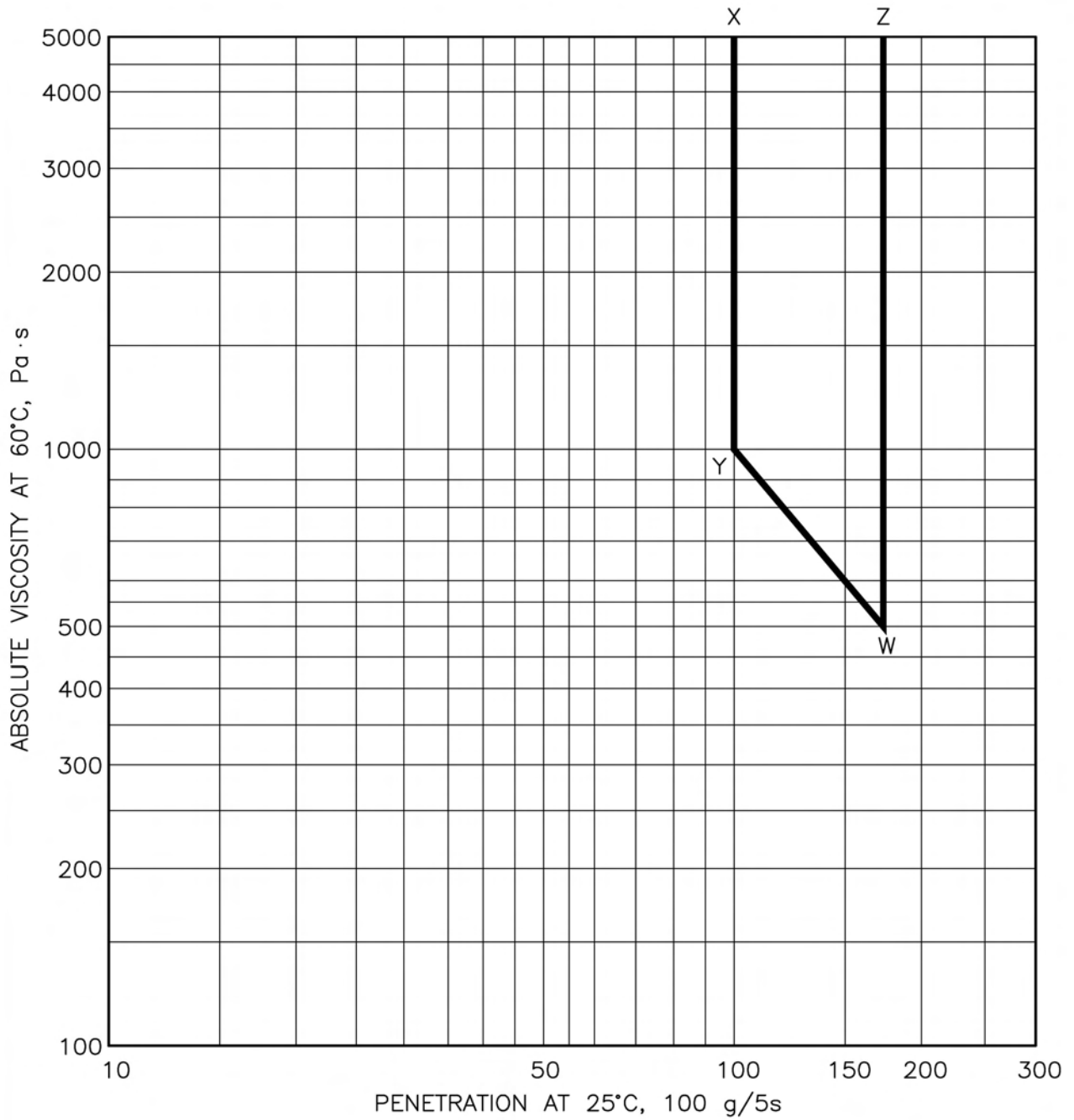

NOTE:
 VISCOSITY SHALL BE WITHIN GRAPHIC REGIONS DESCRIBED BY THE LETTER CO-ORDINATES X, Y, W, Z.

GRADATION OF HIGH FLOAT EMULSIFIED ASPHALT	SP951-03
---	-----------------

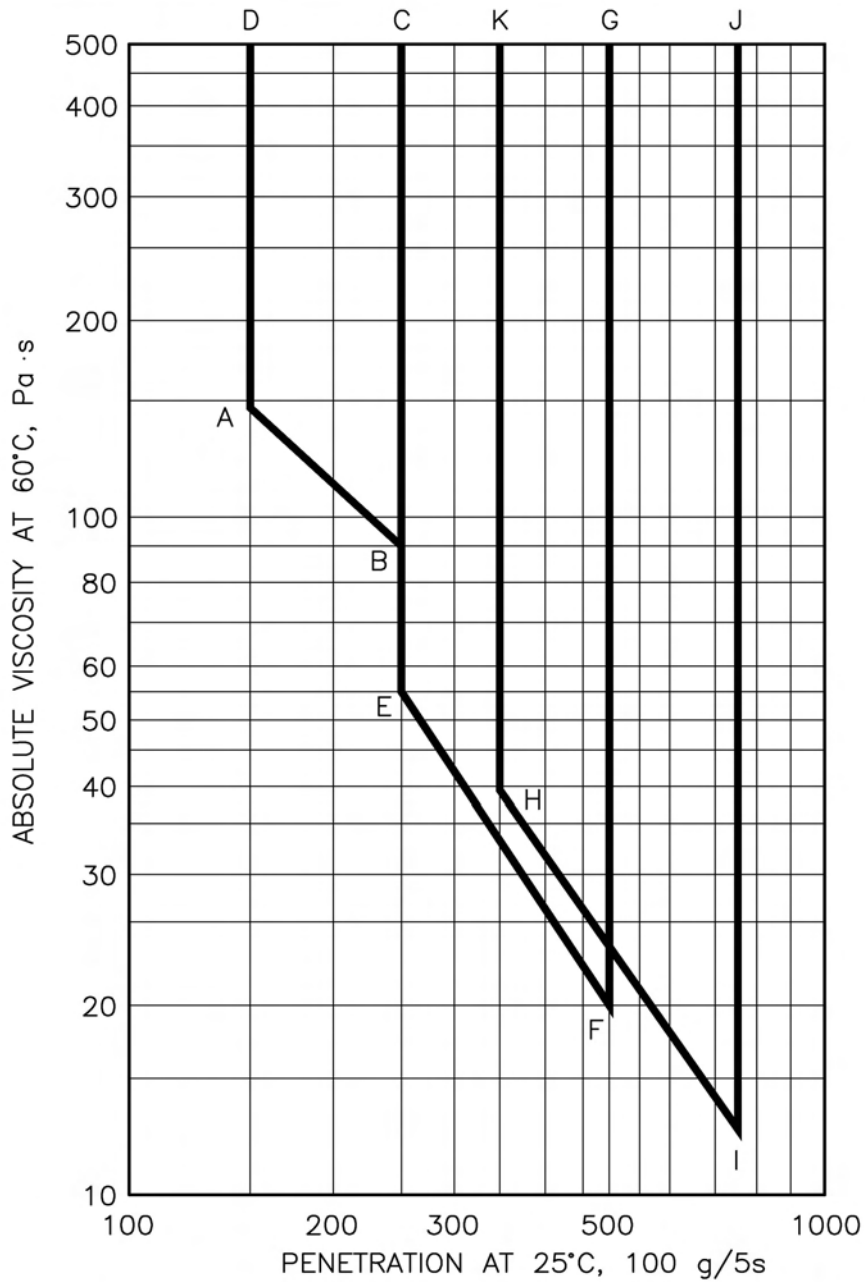

GRADATION OF HIGH FLOAT EMULSIFIED ASPHALT	HF - 150S	HF - 250S	HF - 350S
VISCOSITY AND PENETRATION SHALL BE WITHIN GRAPHIC REGIONS DESCRIBED BY THE LETTER CO-ORDINATES	A, B, C, D	E, F, G, C	H, I, J, K

ABSOLUTE VISCOSITY vs PENETRATION

SP951-04

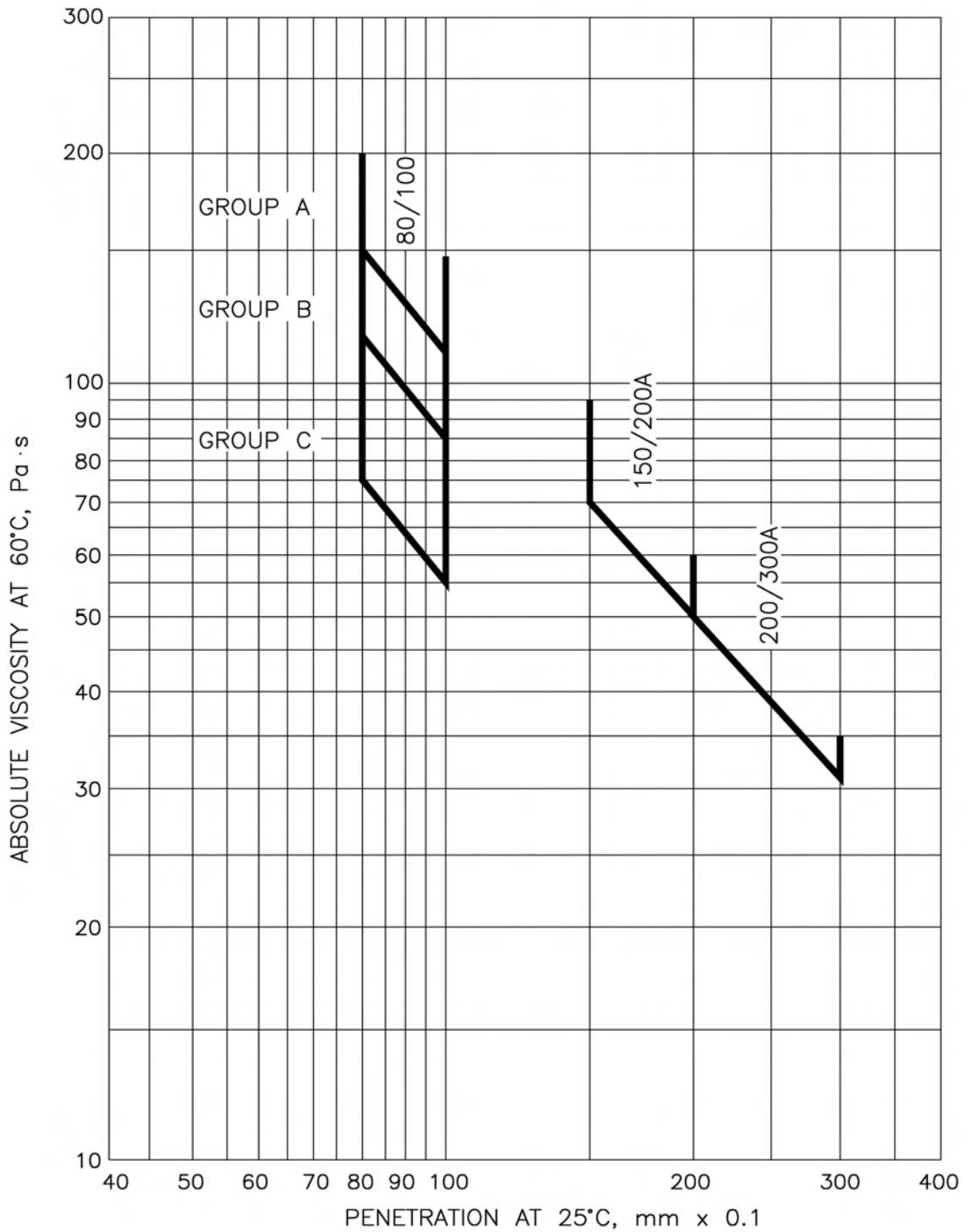

THIS PAGE IS LEFT INTENTIONALLY BLANK

SECTION 952

CONTRACTOR SUPPLY ASPHALT AND PAVING MATERIALS FOR HIGHWAY USE

952.01 Scope

a) This Appendix describes the requirements for the different types and grades of asphalt and paving materials to be supplied by the Contractor for highway use as set out in the Special Provisions of the Contract.

b) The materials so described are generally classified as follows:

- Asphalt Cements
- Cutback Asphalts
- Asphalt Emulsions
- Tall Oil Pitch
- Emulsified Products

c) The term "Supplier" referred to in this section shall mean the party or parties supplying the Contractor with materials covered under this specification.

952.02 Quality Control Requirements

952.02.01 Quality Control Plan

a) The supplier shall develop and maintain a proven quality control plan in accordance with the provisions of this Specification and the Special Provisions. The plan shall ensure that adequate inspection coverage is maintained throughout the entire process of manufacture and shipping. All supplies processed or manufactured within the supplier's plant or procured from any other source shall receive sufficient inspection to ensure conformance specifications.

b) Supplies not conforming to contractual requirements shall not be offered for highway use until the deviations have been authorized by the Ministry Representative.

c) It shall be a responsibility of the Contractor to ensure that all materials supplied satisfy the related Environmental and Health and Safety Regulations.

d) Product discharged directly into tank cars or tank trucks from "in line blending" facilities will be sampled as required to ensure uniformity and satisfy quality requirements.

952.02.02 Quality Control Procedure - The supplier may be required to furnish the Contractor with an outline of the quality control procedures detailing the method of implementing the requirements of this Specification. This outline shall include the following operations:

- sampling and testing
- storage and handling
- shipping

- recording and reporting.

952.02.03 Technical Requirements - The Contractor shall ensure that the supplier provides the following:

a) **Batching and Batch Analysis:** Each batch of product covered by this Specification shall be given a batch number, and sampled and tested in accordance with the applicable Specification.

The batch analysis must show the Specification requirements for the product tested, test method employed, and the pertinent test results, as listed on Appendix A.

Certified batch analysis shall be dispatched to the Contractor with the first load of material delivered. Provided the batch from which shipments are drawn remains the same and provided that the batch number is shown on the Bill of Lading, no further batch analysis will be required for subsequent remaining shipments. If, during the course of delivery, it is necessary to draw material from a different batch or batches of product, the analysis of the replacement batch shall be sent out with the first load of material from each and every replacement batch.

b) A Viscosity Chart (Absolute) with the initial load and for each subsequent batch. If inline blending is utilized a new viscosity chart shall be issued should any change in viscosity occur.

952.03 Sampling and Testing

a) The supplier shall retain adequate sampling equipment, employ satisfactory sampling procedures, and maintain sampling program and records. The Contractor shall obtain samples for quality assurance.

b) Test methods for asphalt and paving materials shall conform to the standard ASTM tests, or to the BCH test where no ASTM test is specified, listed in Table 952-A, supplemented by such special tests as may be described elsewhere to cover special or experimental type materials.

c) On request, the Contractor shall provide samples, from the supplier, of the product in quantities, not less than 4 ℓ, as may be required for independent testing purposes.

952.04 Delivery of Asphalt and Paving Materials

a) The Contractor must ensure the supplier delivers asphalt and paving materials in good condition and at correct temperature to the specified delivery point

b) Every bill of lading must show:

- Type of product

- Batch number
 - Mass
 - Relative density at 15°C
 - P.G. Specification (for information only)
- c) Trucks shall be equipped with a submerged sampling valve system installed generally as shown on Drawing SP952-01 for each compartment in which asphalt material is to be carried out.
- d) Delivery temperature of the shipment shall meet the viscosity requirement shown in Table 952-B.
- e) Asphalt Emulsions and emulsified products shall be kept at temperatures above 5°C.

TABLE 952-A TEST METHODS

TITLE OF TEST	TEST DESIGNATION	
	B.C.H.	ASTM
Penetration		D 5
Absolute Viscosity of Asphalts		D 2171
Kinematic Viscosity of Asphalts		D 2170
Effect of Heat and Air on Asphalt		D 1754
Distillation of Cutback Asphalt		D 402
Residue of 100 Penetration		D 243
Relative Density of Asphalt Cement and Cutback Asphalt		D 70
Ductility		D 113
Float Test		D 139
Flash Point by Tag Open Cup		D 1310
Flash Point by Cleveland Open Cup		D 92
Solubility in Trichloroethylene		D 2042
Water in Asphalt		D 95
Softening Point in Ethylene Glycol		D 2398
Saybolt Furol Viscosity		D 88
Testing Emulsified Asphalts		D 244
Testing High Float Asphalts	IV - 2	

TABLE 952-B VISCOSITY REQUIREMENTS FOR SHIPMENT DELIVERY TEMPERATURE

CLASS OF MATERIAL	KINEMATIC VISCOSITY, mm ² /s
Cutback Asphalt for Surface Spraying	100 - 200
Cutback Asphalt and Asphalt Cement for Plant Mixing	100 - 500
Tall Oil Pitch	20 - 40

Note: In no case shall asphalt materials or Tall Oil Pitch be received at a viscosity outside the specified viscosity range.

952.05 Asphalt Cement - Asphalt cements shall:

- a) Be products prepared by the refining of petroleum oils.
- b) Be homogeneous, free from water and shall not foam when heated to 175°C.
- c) Conform to the requirements specified in Table 952-C and Table 952-D.

The Contractor shall forward a 4 ℓ sample of the product to the Ministry Representative.

NOTE: Values for penetration and viscosity are point values only. Intermediate values for Group A, B and C grades shall be obtained by interpolation between the tabulated values on a straight line basis. Minimum viscosity at 60°C for other penetrations within each group can be read from the corresponding straight line on Drawing SP952-02.

952.06 Cutback Asphalts

- a) Cutback asphalts shall consist essentially of petroleum derivatives and shall be substantially free from water and other impurities.
- b) Cutback asphalts shall be of the type and grade described in Tables 952-E to 952-H.

952.07 Asphalt Emulsions - Asphalt materials in the form of aqueous emulsions shall be of:

- Anionic Type
- Cationic Type
- High Float Type

952.08 Anionic Type Emulsion for Road Purposes -

Anionic type of emulsion requirements are as follows:

- The asphalt emulsion shall be homogeneous.
- It shall show no separation of asphalt after thorough mixing within 30 days (crack filler 20 days) after delivery, provided separation has not been caused by freezing.
- The emulsion shall conform to the requirements listed in Table 952-I.

952.09 Cationic Type Emulsions for Road Purposes -

Cationic type emulsions shall conform to the requirements listed in Table 952-J and shall be uniform throughout.

952.10 High Float Emulsified Asphalt - Storage stability - High float emulsified asphalt shall show no separation of asphalt within 30 days after delivery and shall be homogeneous after thorough mixing.

The emulsion shall conform to the requirements listed in

Table 952-K.

952.11 Tall Oil Pitch (TOP) - Tall oil pitch, co-product of the pulp and paper industry is a residual fraction from the crude tall oil vacuum distillation process. It shall be a dark brown resinous and viscous material insoluble in water but miscible with asphalt. TOP is typically used by the Ministry as an asphalt extender, recycling, and anti-stripping agent. Where required, TOP will be added to asphalt cement in a ratio defined by the mix design, usually between 5 - 10%. The composition and properties of TOP depends on the origin and type of trees from which it is derived and the extraction technology. Only TOP approved by the Ministry's New Product Standing Committee shall be permitted for use on Ministry paving projects.

The TOP shall conform to the requirements listed in Tables 952-L and 952-M.

952.12 Emulsified Products - Emulsified products consist of emulsified Tall Oil Pitch and proprietary asphalt based emulsions. The emulsified products are typically used by the Ministry, in paving operations, as prime coats and tack coats and replace organic solvent based cutback asphalts for environmental reasons. Only products approved by the Ministry's New Product Standing Committee shall be permitted for use on the Ministry paving projects. Each batch of the product delivered to the job site shall be accompanied by the written statement from the manufacturer or supplier confirming that the product formulation complies with the original, previously approved formulation. Emulsified Tall Oil Pitch and asphalt based emulsified products shall conform to the requirements listed in Tables 952-N and 952-O.

TABLE 952-C GRADES OF ASPHALT CEMENT

PENETRATION GRADE ASPHALT CEMENT	80 - 100		150 - 200		200 - 300		TEST METHOD ASTM
	Min	Max	Min	Max	Min	Ma	
Requirements							D 5
Penetration at 25°C 100 g and 5 s, 0.1 mm	80	100	150	200	200	300	
Group A Group B Group C	Minimum viscosity values defining boundaries for groups A, B, & C are listed in Table 952-D and illustrated in Drawing SP952-04						
Flash Point, °C Cleveland Open Cup	230	---	220	---	175	---	D 92
Thin Film Oven Test % Loss in Mass	---	0.85	---	1.3	---	1.5	D 1754
Penetration of Residue at 25°C 100 g, 5 s, 0.1 mm, % of Original Penetration	55	---	50	---	45	---	After T.F.O.T.
Solubility in Trichloroethylene % by Mass	99.5	---	99.5	---	99.5	---	D 2042
Ductility, 25°C 5 cm/min, cm	100	---	100	---	---	---	D 113
Ductility, 15°C 5 cm/min, cm	---	---	---	---	100	---	

TABLE 952-D VISCOSITY AND PENETRATION VALUES DEFINING GROUP BOUNDARIES

Penetration 25°C	80	100	150	200	300	TEST METHOD - ASTM
	Minimum Viscosity at 60°C					D 2171
Group A	150	115	70	50	31	
Group B	110	85	---	---	---	
Group C	75	55	---	---	---	

TABLE 952-E SLOW CURING CUTBACK ASPHALT

REQUIREMENTS	GRADE					
	SC - 70		SC - 250		SC - 3000	
	Min	Max	Min	Max	Min	Max
Flash Point °C	65	---	80	---	105	---
Kinematic Viscosity at 60°C, mm ² /s	70	140	250	500	3 000	6 000
Residue from Distillation to 360°C, volume % by difference	70	90	80	94	95	---
Distillation Residue, Kinematic Viscosity at 60°C, mm ² /s	400	7 000	800	10 000	4 000	35 000
ASPHALT RESIDUE:						
Residue of 100 Penetration, % by Mass	50	---	60	---	80	---
Ductility of 100 Penetration residue at 25°C, cm	100	---	100	---	100	---
Solubility in Trichloroethylene	99.0	---	99.0	---	99.0	---
Water, % by Mass or Volume	---	0.5	---	0.5	---	0.5

TABLE 952-F MEDIUM CURING CUTBACK ASPHALT

REQUIREMENTS	GRADE			
	MC - 30		MC - 250	
	Min.	Max.	Min.	Max.
Flash Point °C	38	---	65	---
Kinematic Viscosity at 60°C, mm ² /s	30	60	250	500
Distillation Test, % of Total Distillate to 360°C: to 225°C	---	25	---	10
Distillation Test, % of Total Distillate to 360°C: to 260°C	40	70	15	55
Distillation Test, % of Total Distillate to 360°C: to 315°C	75	93	60	87
Residue from Distillation to 360°C, volume % by difference	50	---	67	---
PROPERTIES OF RESIDUE FROM DISTILLATION:				
Penetration at 25°C, 100 g, 5 s, 0.1 mm	120	250	120	250
Ductility at 25°C, cm	100	---	100	---
Solubility in Trichloroethylene	99.0	---	99.0	---
Water, %	---	0.2	---	0.2

TABLE 952-G RAPID CURING CUTBACK ASPHALT

REQUIREMENTS	GRADE					
	RC - 30		RC - 70		RC - 250	
	Min	Max	Min	Max	Min	Max
Flash Point °C	---	---	---	---	27	---
Kinematic Viscosity at 60°C, mm ² /s	30	60	70	140	250	500
Distillation Test, % of Total Distillate to 360°C: to 190°C	15	---	10	---	---	---
Distillation Test, % of Total Distillate to 360°C: to 225°C	55	---	50	---	35	---
Distillation Test, % of Total Distillate to 360°C: to 260°C	75	---	70	---	60	---
Distillation Test, % of Total Distillate to 360°C: to 315°C	90	---	85	---	80	---
Residue from Distillation to 360°C, volume % by difference	50	---	55	---	65	---
TEST ON RESIDUE FROM DISTILLATION:						
Penetration at 25°C, 100 g, 5 s, 0.1 mm	80	120	80	120	80	120
Ductility at 25°C, cm	100	---	100	---	100	---
Solubility in Trichloroethylene, % by mass	99.0	---	99.0	---	99.0	---
Water, %	---	0.2	---	0.2	---	0.2

Note: The material shall not foam when heated to the spraying and mixing temperature range recommended by the Canadian General Standards Board

TABLE 952-H CUTBACK ASPHALT PRIMER RM20

REQUIREMENTS	Min.	Max.
Kinematic Viscosity at 60°C, mm ² /s	20	35
Distillation Test, % of Total Distillate to 360°C: to 190°C	---	60
Distillation Test, % of Total Distillate to 360°C: to 225°C	40	---
Distillation Test, % of Total Distillate to 360°C: to 260°C	70	---
Distillation Test, % of Total Distillate to 360°C: to 315°C	85	---
Residue from Distillation to 360°C, volume % by difference	50	---
TEST ON RESIDUE FROM DISTILLATION:		
Penetration at 25°C, 100 g, 5 s, 0.1 mm	80	200
Ductility at 25°C, cm	100	---
Solubility in Trichloroethylene	99.0	---
Water, %	---	0.2

TABLE 952-I REQUIREMENTS FOR ANIONIC TYPE EMULSIONS

REQUIREMENT	TYPE OF EMULSION									
	RS - 1		RS - 2		MS - 2		SS - 1		CRACK FILLER	
	Min	Max	Min	Max	Min	Max	Min	Max	Min	Max
Viscosity, Saybolt Furol: at 25°C	20	100	---	---	100	---	20	100	50	200
Viscosity, Saybolt Furol: at 50°C	---	---	75	300	---	---	---	---	---	---
Residue by Distillation, %	57	---	62	---	62	---	57	---	65	75
Settlement, 1 Day, %	---	1.5	---	1.5	---	1.5	---	1.5	---	1.5
Demulsibility: 50 mL of 0.1 N CaCl ₂ %	---	---	---	---	---	30	---	---	---	---
Demulsibility: 35 mL of 0.02 N CaCl ₂ %	60	---	60	---	---	---	---	---	30	---
Sieve Test, % Retained on 1 mm	---	0.10	---	0.10	---	0.10	---	0.10	---	0.10
Cement Mixing Test, %	---	---	---	---	---	---	---	2.0	---	---
TESTS ON RESIDUE:										
Penetration at 25°C, 100 g, 5 s	100	200	100	200	100	200	100	200	60	100
Solubility in Trichloroethylene %	97.5	---	97.5	---	97.5	---	97.5	---	97.5	---
Ductility at 25°C, cm	60	---	60	---	60	---	60	---	60	---

TABLE 952-J REQUIREMENTS FOR CATIONIC TYPE EMULSIONS

REQUIREMENT	TYPE OF EMULSION			
	CRS - 1K		CRS - 2K	
	Min	Max	Min	Max
Saybolt Furol Viscosity at 50°C	30	125	174	400
% Residue by Distillation	62	---	68	---
Settlement 1 Day, %	---	1.5	---	1.5
Sieve Test, % Retained on 1 mm Mesh	---	0.1	---	0.1
Oil Portion of Distillate, % of Total Volume	0	3	0	3
Particle Charge	POSITIVE		POSITIVE	
TESTS ON RESIDUE				
Penetration at 25°C, 100 g, 5 s	100	250	100	150
Solubility in Trichloroethylene %	97.5	---	97.5	---
Ductility at 25°C, cm	60	---	65	---

TABLE 952-K REQUIREMENTS FOR HIGH FLOAT EMULSIFIED ASPHALTS

REQUIREMENT	GRADE											
	HF-100S		HF-150S		HF-250S		HF-350S		HF-500M		HF-1000M	
	Min	Max	Min	Max	Min	Max	Min	Max	Min	Max	Min	Max
Residue by Distillation, % By Mass	62	---	62	---	62	---	65	---	65	---	65	---
Oil Distillate % By Volume	1	4	0.5	4	1	6	1.5	6	1	6	1	7
Saybolt Viscosity, Furol Seconds at 50°C	35	150	35	150	35	150	75	400	50	---	50	---
Sieve Test, % Retained on 1 mm Sieve	---	0.1	---	0.1	---	0.1	---	0.1	---	0.1	---	0.1
Coating Test %	90	---	90	---	90	---	---	---	---	---	---	---
Settlement 1 Day, % By Mass	---	1.5	---	1.5	---	1.5	---	1.5	---	1.5	---	1.5
Demulsibility: 50 mL 5.55 g/L CaCl ₂ , % By Mass	75	---	75	---	---	---	---	---	---	---	---	---
Workability @ 10°C	---	---	---	---	---	---	---	---	---	---	Pass	---
TEST ON RESIDUE												
Penetration at 25°C, 100 g, 5 s	*		**		**		**		---	---	---	---
Viscosity at 60°C, Pa·s	*		**		**		**		8	20	2	8
Float Test at 60°C, s	1200	---	1200	---	1200	---	1200	---	1200	---	1200	---
Solubility in Trichloroethylene, %	97.5	---	97.5	---	97.5	---	97.5	---	97.5	---	97.5	---

* See Drawing SP952-02

** See Drawing SP952-03

TABLE 952-L TALL OIL PITCH VISCOSITY AND PENETRATION DATA

REQUIREMENTS	Min.	Max.
Results on original sample		
Absolute Viscosity, 60°C, PaCs	1	2
Kinematic Viscosity, 135°C, mm ² /s	25	35
Penetration, 4°C/100g, 5 sec, 0.1 mm	150	250
Results after Thin Film Oven		
Loss in weight, %	---	0.65
Absolute Viscosity, 60°C, PaCs	---	3
Kinematic Viscosity, 135°C, mm ² /s	---	60
Penetration, 4°C, 100 g, 5 sec, 0.1 mm	75	---

TABLE 952-M TALL OIL PITCH DATA

REQUIREMENTS	Min.	Max.
Softening Point, °C (ASTM D 36)	---	35
Flash Point, Cleveland Open Cup, °C (ASTM D 92)	250	---
Fire Point, Cleveland Open Cup, °C (ASTM D 92)	275	---
Boiling Point, °C	320	---
Specific Gravity	0.94	0.98
Vapour Pressure, mm Hg	---	1
PH	3.75	4.25
Wood Extractive, %	98	---
Ash, % (ASTM D 803)	---	0.8
Moisture, % (ASTM D 803)	---	0.1
Fatty Acids, %	7	9
Resin Acids, %	5	7
Unsaponifiables, %	39	44
Neutrals, %	42	46
Acid Number	20	30

TABLE 952-N EMULSIFIED TALL OIL PITCH

REQUIREMENTS	Min.	Max.
Viscosity, SF, 25°C, s	10	30
Residue by Distillation, % by weight	40	---
Oil Distillate, % by volume	---	0.1
Settlement 24hrs, %	---	1.5
pH	6	8
Particle Charge	Negative	
Miscibility with Water	Pass	
Specific Gravity, 20°C	Approx. 1.0	
Boiling Point, °C	100	
Freezing Point, °C	0	
Vapour Pressure, mm Hg	20	
Odour and Appearance - distinctive resinous Odour, light yellow colour		
TEST ON RESIDUE - Shall conform to the requirements for Tall Oil Pitch listed in table 951-L		

TABLE 952-O EMULSIFIED PRODUCTS

REQUIREMENTS	Min.	Max.
Viscosity, SF, 25°C, s	10	60
Residue by Distillation, % by weight	40	---
Oil Distillate, % by Volume	---	5
Settlement 24hrs, %	Pass	
Miscibility with Water	Pass	
TEST ON RESIDUE		
Penetration, 25°C, 100 g, 5 sec, 0.1 mm	40	200

APPENDIX A

The following data is required from the supplier:

ASPHALT CEMENTS

Grade and Type (when required)

A. Original Asphalt

Density @ 15°C, kg/L

- Viscosity @ 135°C
- Viscosity @ 60°C
- Penetration @ 25°C, 100 g/5 s
- Solubility in Trichloroethylene
- Ductility @ 25°C
- Flash Point C.O.C.
- % Retained Penetration after T.F.O.T. @ 25°C

B. Residue After T.F.O.T.

(when Type A required)

- Penetration @ 25°C
- Penetration @ 10°C
- Penetration @ 4°C

NOTE: Viscosity - Temperature chart also required for each batch.

CUTBACK ASPHALTS

A. Cutback Asphalts as Supplied

- Flash Point, T.O.C. (C.O.C. above 79°C)
- Density @ 15°C, g/cm³
- Viscosity @ 60°C, mm²/s
- Distillate, % by volume of Total
 - Distillate to 360°C
 - Distillate to 190°C
 - Distillate to 225°C
 - Distillate to 260°C
 - Distillate to 315°C
- Residue from Distillation to 360°C
- Volume % by Difference

B. Properties of Residue

- Penetration @ 25°C
- Ductility @ 25°C
- Solubility in Trichloroethylene, %

C. Residue of 100 Penetration by Mass

- Ductility of 100 Penetration at 25°C, cm

EMULSIONS

A. Original Emulsion

- Saybolt Furol Viscosity @ 25°C
- Saybolt Furol Viscosity @ 50°C
- % Residue by Distillation
- Settlement in 5 Days, %
- Oil Portion of Disillate

B. Tests on Residue

- % to Total Volume
- Float Test @ 60°C, s
- Penetration @ 25°C, 100 g/5 s
- Ductility @ 25°C

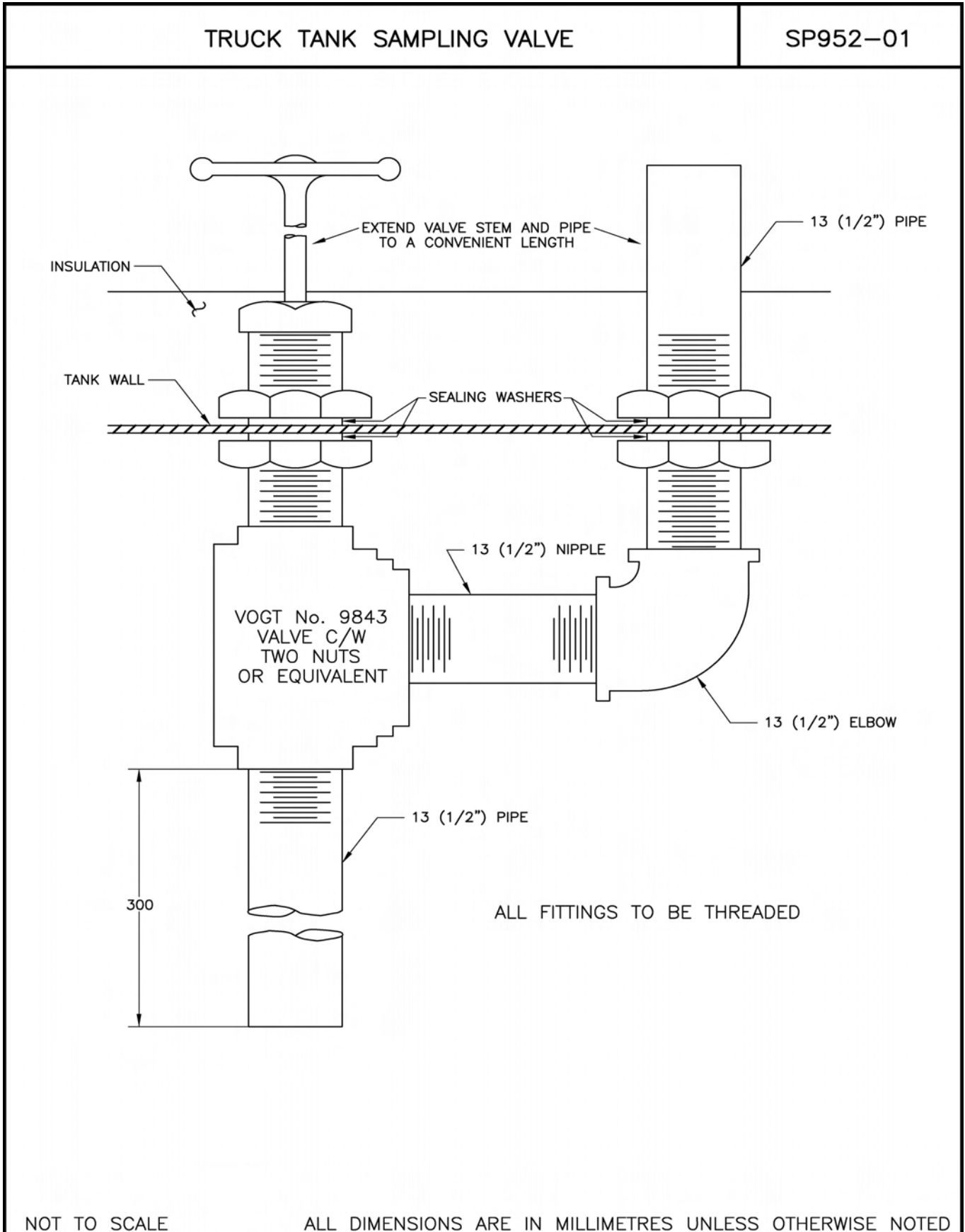

VISCOSITY REQUIREMENTS FOR DISTILLATION RESIDUES
FROM HIGH FLOAT EMULSIFIED ASPHALT, HF-100S

SP952-02

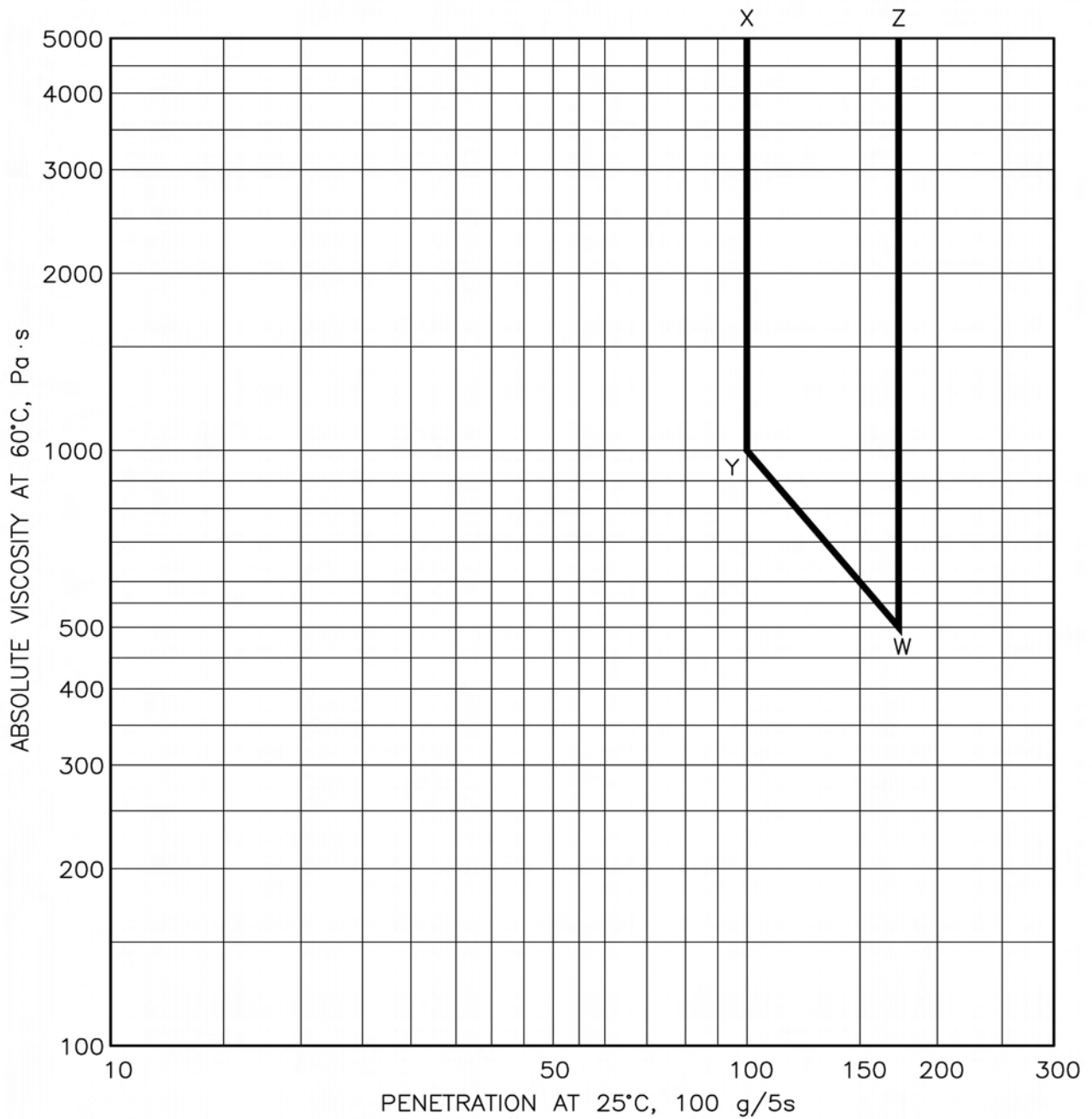

NOTE:
VISCOSITY SHALL BE WITHIN GRAPHIC REGIONS DESCRIBED
BY THE LETTER CO-ORDINATES X, Y, W, Z.

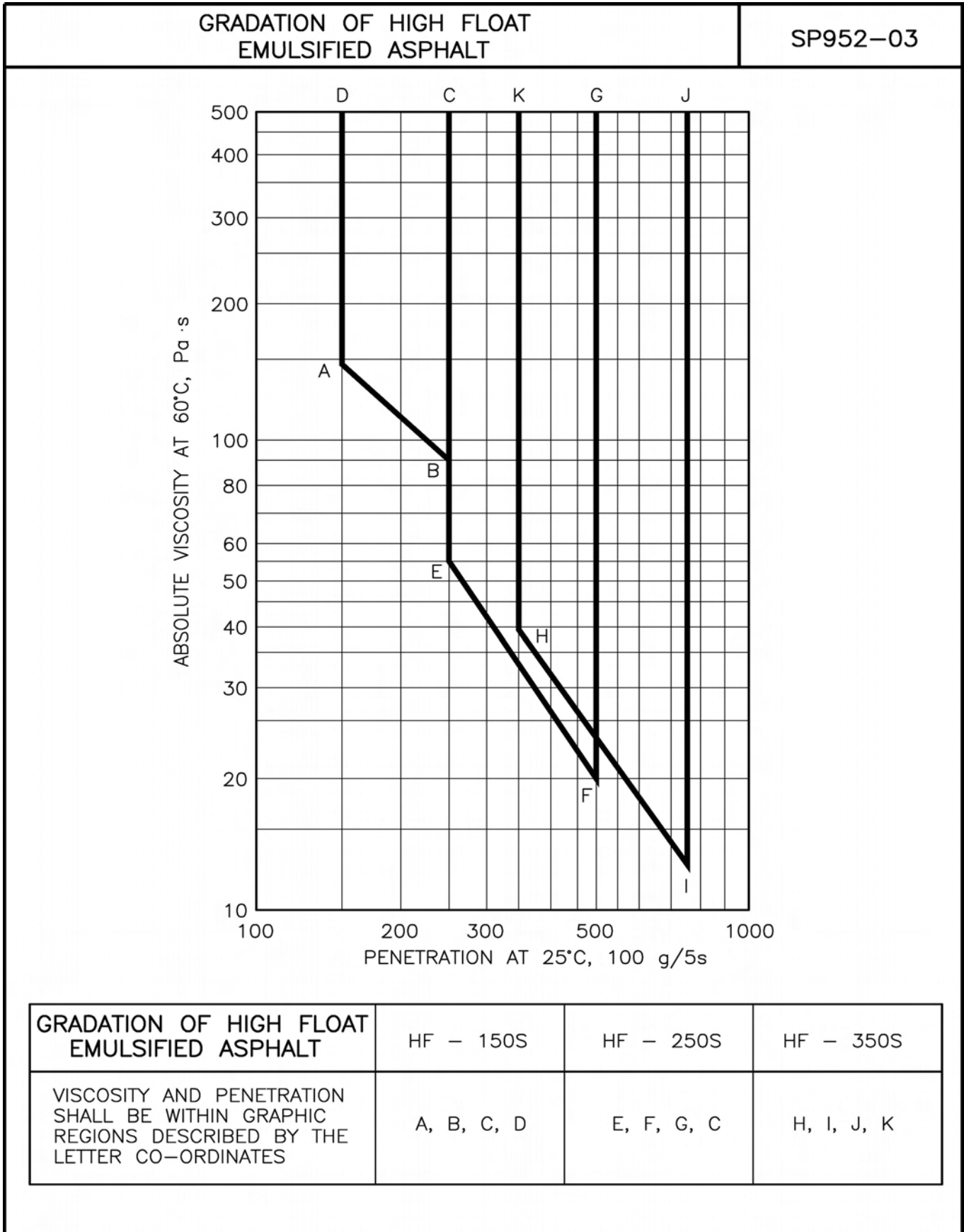

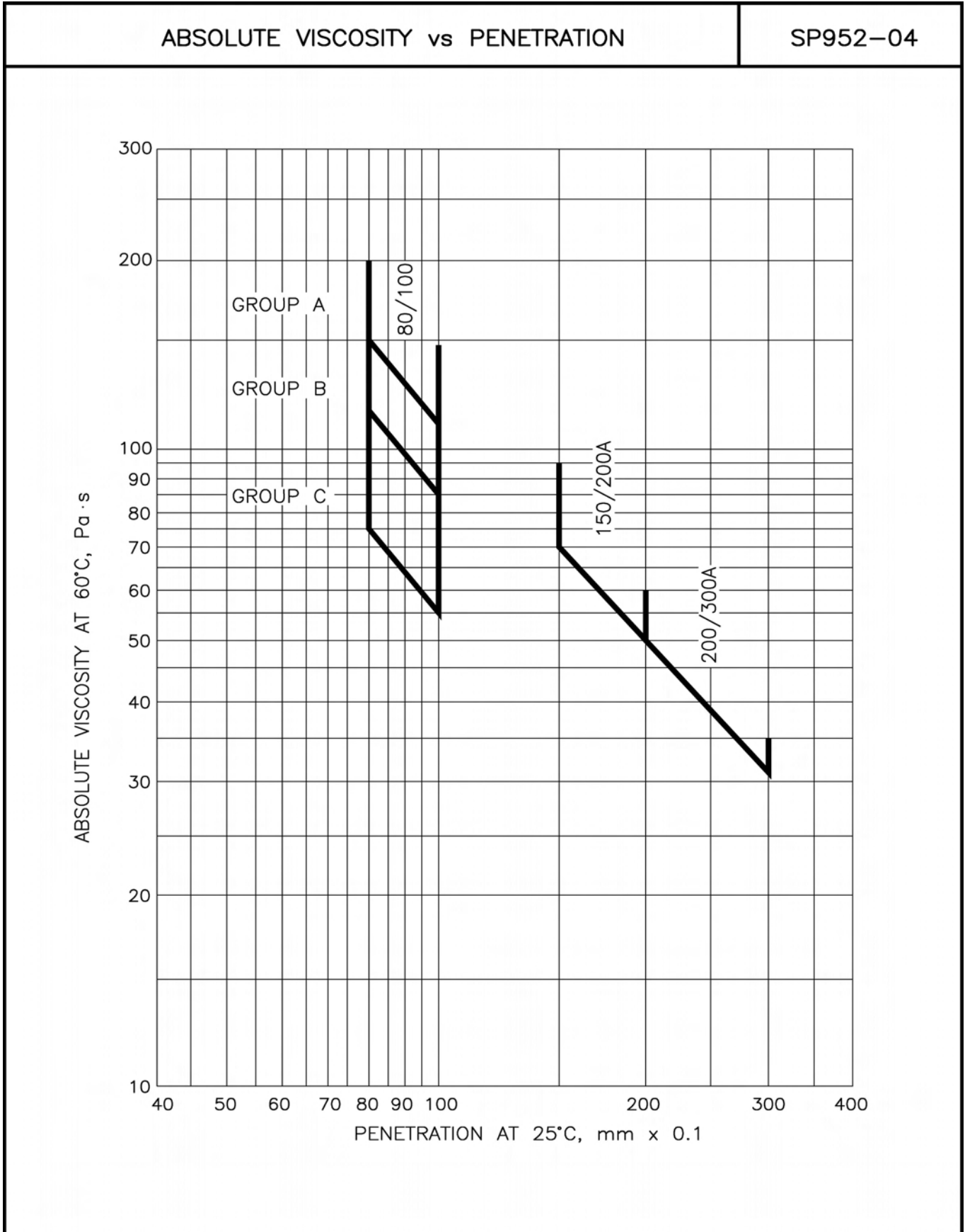

SECTION 971

PLASTIC TRAFFIC CONES

971.01 Scope - This Section applies to plastic traffic cones used to provide a temporary traffic guidance system for vehicles and pedestrians under daylight conditions. Their use is primarily associated with maintenance and construction or similar roadway operations.

971.02 Classification

- a) Cones shall be supplied in three nominal sizes: 150 mm, 450 mm, and 700 mm.
- b) Cones shall be supplied in one type only: "High Stability, High Visibility, Fluorescent."
- c) Cones shall be of such quality that when used, stored and handled with reasonable care they shall have a service life of at least two years. At the end of this period the cones shall be substantially undamaged and shall meet the requirements of this specification with respect to visibility and colour.

971.03 General Requirements

- a) Upper portion of the cone shall be made of a suitable thermoplastic with physical properties adequate for the intended service in British Columbia and pigmented to provide a high visibility fluorescent colour. If necessary, to meet the colour and visibility requirements, an inner white liner may be used. The white liner shall be of substantially the same material as the outer section and shall be securely fused to it. The base of the cone shall be made of a high density mineral filled thermoplastic to provide high stability to the cone. The use of separate metal weights in the base is not permitted. The base and upper portion of the cone shall be fused together, this joint shall not constitute an area of weakness and shall be reinforced if necessary.
- b) The cone shall be of uniform taper from top to bottom to permit the cones to be nested efficiently. The surfaces of the cone shall be uniformly smooth so that the cones may be easily separated from the stack.
- c) Voids on the surface or within the plastic material will not be permitted.

971.04 Dimensions - Minimum dimensions shall be as shown in Table 971-A.

TABLE 971-A MINIMUM DIMENSIONS

NOMINAL SIZE	HEIGHT (mm)	BASE (SQUARE) (mm)	OUTSIDE DIAMETER AT BOTTOM (mm)	OUTSIDE DIAMETER AT TOP (mm)	WALL THICKNESS (mm)
150	150	150	90	50	1.8
450	450	275	180	50	2.0
700	700	360	350	50	2.2

Wall thickness shall be measured not closer than 25 mm from top or bottom of the cone.

Note: 150 mm cones to be used for centrelining operations shall have a maximum outside diameter at the bottom of 105 mm and maximum outside diameter at the top of 55 mm.

971.05 Mass - The minimum total mass and the minimum mass of base as a percentage of the total mass shall be as shown in Table 971-B.

TABLE 971-B MASS

NOMINAL SIZE	TOTAL MASS (g)	MASS OF BASE AS % OF TOTAL
150	475	75
450	2200	65
700	3200	50

971.06 Tensile Properties - The tensile properties of the thermoplastic from the upper portion of the cone shall be as shown in Table 971-C when tested in accordance with ASTM D 638

TABLE 971-C TENSILE PROPERTIES

Minimum Ultimate Tensile Strength	7000 kPa
Minimum % Elongation	200%
Minimum Tensile Stress at 200% Elongation	6000 kPa

971.07 Colour - The colour of the upper portion of the cone shall be fluorescent red and will be accepted on visual matching with CGSB Colour 1-GP-12 Red 609-401. Cones with slight colour mismatch towards Orange 608-401 will be accepted. Cones with colour mismatch towards white (i.e., pink) or towards black (i.e., a darker red) will not be accepted. Fluorescence is defined in this case as the property of emitting visible light as the result of absorption of ultra violet light. (Test Method CGSB 1-GP-71 Method 12.9 using North daylight)

971.08 Resistance to Colour Change - The upper cone material shall withstand 80 hours in an Atlas Twin Arc Fadeometer without appreciable change in colour, neither fading nor darkening. The reflectance factor (ASTM E 97) should not vary by more than three units before and after exposure. (CGSB 1-GP-71 Test Method 120.1.)

971.09 Specular Gloss - The 60 degree Specular Gloss (ASTM D 523) of the upper cone material shall be not less than 70 units. Gloss readings shall be taken on a cut section of cone approximately 100 mm square firmly bonded to a flat surface. (Test Method ASTM D 523.)

971.10 Recovery after Bending - The cone when placed in its normal position on a flat and level surface and folded at a point near the middle of its vertical height so that the upper tip touches the surface on which the base is resting and when held there for 10 seconds shall upon release return to its original shape and vertical position within 15 seconds. This requirement shall be met when the cone and ambient temperatures are $20^{\circ}\text{C} \pm 1^{\circ}\text{C}$.

971.11 High Temperature Requirement - The cone must be self-supporting with no appreciable slump or sag after four hours exposure at a temperature of $65^{\circ}\text{C} \pm 1^{\circ}\text{C}$.

971.12 Resistance to Flexing - The surface of the cone shall not crack, permanently crease or discolour when the cone is bent sharply at a 180 degree angle and flexed 25 times.

971.13 Cold Temperature Requirement - The cone, after cooling for four hours in a freezing chamber set at -25°C , shall be able to withstand one passage of the test vehicle wheels without evidence of cracking, splitting, breaking or other damage. The cone will be held in a wooden restraining device with the test site ambient air temperature sensibly constant and within the range of $10^{\circ}\text{C} \pm 3^{\circ}\text{C}$. The elapsed time between removal of the cone from the freezing chamber and performance of the test shall not exceed 15 seconds. The test vehicle shall have a gross mass of 1850 ± 50 kg, travel at 10 ± 1 km per hour, and be equipped with H78-15 summer tread pattern tire inflated to 220 kPa (32 p.s.i.).

971.14 Blower Resistance - No significant movement of any cone shall occur when a 48 passenger standard bus is driven by three times at a distance of 150 mm (cone base edge to tire edge) from a line of five test cones from one

supplier. The bus speed shall be 100 kilometres per hour. There shall be no appreciable ambient wind and the pavement shall be dry.

971.15 Stacking Qualities - When cones are nested together the base of each cone shall be substantially in contact with the top of the base of the cone immediately below it in the stack. The maximum separation between the bases of the stacked cones shall not exceed 6 mm.

When cones are stacked together one on top of the other each cone shall be capable of being lifted easily from the stack without binding or jamming on the cone below it.

971.16 Marking - Letters reading "B.C. GOVT.", or as otherwise specified on the Purchase Order, 25 mm minimum high shall be indelibly marked on the upper surface of the base of the cone in a colour contrasting to the colour of the base.

971.17 Bid Samples - Each bidder shall submit the following number of cones for purposes of defining the quality level of their bid samples:

- 150 mm high cones - 15 units
- 450 mm high cones - 10 units
- 700 mm high cones - 10 units

These bid samples will be requested from the suppliers by the Ministry Purchasing Commission.

971.18 Inspection - Cones shall be inspected and tested prior to shipment. At least two cones of each type ordered will be sampled from each shipment from the supplier's manufacturing plant if in British Columbia or from the supplier's warehouse in British Columbia if cones are manufactured outside of the Province.

Upon successful completion of inspection and testing, a Release for Shipment will be issued; this, however, shall not be a bar to subsequent rejection of individual cones or the entire shipment should they be found to fail any requirements of this Specification.

SECTION 991

CALCIUM CHLORIDE AND SODIUM CHLORIDE

991.01 Calcium Chloride - Calcium chloride, for highway purposes, shall conform to CGSB Specification 15-GP-1M Calcium Chloride. It shall be supplied as Type I Regular (77%) bulk (flake) or sacked, or as liquid at 35% solution concentration, as specified.

991.02 Sodium Chloride - Sodium chloride, for highway purposes, shall conform to CGSB Specification 15-GP-9M Sodium Chloride, Pavement De-icer but it shall be supplied as shown in Table 991-A.

TABLE 991-A GRADATION FOR SODIUM CHLORIDE

SCREEN SIZE	PERCENT PASSING
12.0 mm (1/2")	100
9.00 mm (3/8")	90 - 100
4.75 mm (#4)	35 - 85
2.40 mm (#8)	15 - 55
1.20 mm (#16)	5 - 30
0.600 mm (#30)	0 - 10

991.03 Chemical Contamination of Road Salt - When applied as specified, the de-icing chemicals shall not contain substances that exceed the current environmental guidelines, Provincial or Federal, and shall not cause harm to flora and fauna.

Note: CGSB Specifications are obtainable from:

Canadian General Standards Board
Place du Portage III, 6B1 11 Laurier Street
Gatineau, Quebec

K1A 1G6

Canada

www.tpsgc-pwgsc.gc.ca/cgsb/home/index-e.html

THIS PAGE IS LEFT INTENTIONALLY BLANK