

2009 STANDARD SPECIFICATIONS FOR HIGHWAY CONSTRUCTION

Adopted October 1, 2008

Volume 1 of 2



BRITISH
COLUMBIA

The Best Place on Earth

Ministry of
Transportation
and Infrastructure

2009 STANDARD SPECIFICATIONS FOR HIGHWAY CONSTRUCTION

VOLUME 1

**Adopted
October 1, 2008**

Construction and Maintenance Branch
Ministry of Transportation and Infrastructure

Canadian Cataloguing in Publication Data

British Columbia. Ministry of Transportation and
Infrastructure.

Standard specifications for highway construction
effective February 1,...-- 1991 -

Annual.

ISSN 1188-0120 = Standard specifications for
highway construction (Victoria)

1. Roads - Specifications - British Columbia. I.
Title.

TE27.B7B74

625.7

C91-092305-1

NOTICE TO USERS

SECTIONS 101 to 586 - VOLUME ONE

SECTIONS 604 to 991 - VOLUME TWO

All text significantly changed or added since the 2006 edition is shown with single underlining and a vertical bar in the margin. Deletions and minor corrections such as typos have not been marked.

To obtain the Standard Specifications for Highway Construction Volume - 1 & 2 - 2009

- Order online at <http://www.publications.gov.bc.ca/> , click on general public go shopping button and in the “search” field type in 7680002870, the Queen’s Printer stock number, select the item and click the “add to shopping cart” button. You will require a Visa or MasterCard to process this order. (Visa and/or MasterCard information is stored on our secure server)
- Mail in a Company Cheque, Money Order or Certified Cheque payable to the Minister of Finance to:

Queen’s Printer,
Government Publication Services,
Box 9452, Stn Prov Govt
Victoria BC V8W 9V7
- Phone toll free 1 800 663-6105 or locally in Victoria at 387-6409, with your Visa or MasterCard Number and we will place the order for you.

To view the electronic version of these specifications go to:

http://www.th.gov.bc.ca/Publications/const_maint/contract_serv/standardspecs.htm

For technical content please contact:

Construction Contracts Engineer
Construction and Maintenance Branch
Ministry of Transportation
940 Blanshard Street Level 4C
PO Box 9850 STN PROV GOVT
Victoria BC V8W 9T5

Telephone: (250) 387-7752 or (250) 387-6931
Facsimile: (250) 356-7276

THIS PAGE IS LEFT INTENTIONALLY BLANK

SECTION TITLES

VOLUME ONE CONTAINS THE FOLLOWING SECTIONS:

SECTION 101 - QUALITY MANAGEMENT
SECTION 108 - SAMPLE FORMS
SECTION 125 - VALUE ENGINEERING - PROPOSAL GUIDELINES
SECTION 135 - CONSTRUCTION SITE SAFETY (**REVISED SECTION**)
SECTION 145 - GENERAL REQUIREMENTS FOR HIGHWAY, BRIDGE AND MARINE
CONSTRUCTION
SECTION 165 - PROTECTION OF THE ENVIRONMENT
SECTION 194 - TRAFFIC MANAGEMENT FOR WORK ZONES
SECTION 200 - CLEARING AND GRUBBING
SECTION 201 - ROADWAY AND DRAINAGE EXCAVATION
SECTION 202 - GRANULAR SURFACING, BASE AND SUB-BASES
SECTION 204 - ROCK CUTS
SECTION 205 - RIPRAP
SECTION 206 - ROCK BOLTS
SECTION 207 - SLOPE MESH FOR ROCK CUTS
SECTION 208 - DRAINS FOR ROCK CUTS
SECTION 209 - SHOTCRETE FOR ROCK CUTS
SECTION 211 - PORTLAND CEMENT CONCRETE
SECTION 213 - TIMBER BRIDGES - CONSTRUCTION
SECTION 214 - TIMBER PILING CONSTRUCTION
SECTION 215 - BRIDGES
SECTION 216 - COATING OF STEELWORK
SECTION 218 - CONCRETE FOR MINOR WORKS
SECTION 232 - METAL BIN-WALL
SECTION 303 - CULVERTS
SECTION 308 - COATING SYSTEMS (**REVISED SECTION**)
SECTION 312 - STEEL TRAFFIC BARRIERS AND WOOD POSTS
SECTION 316 - STEEL AND WIRE FENCE MATERIALS
SECTION 317 - P.E. PLASTIC DRAINAGE PIPE (**REVISED SECTION**)
SECTION 318 - PVC PLASTIC DRAINAGE PIPE
SECTION 320 - CORRUGATED STEEL PIPE
SECTION 321 - TRAFFIC PAINT
SECTION 407 - FOUNDATION EXCAVATION (**REVISED SECTION**)
SECTION 412 - CONCRETE REINFORCEMENT
SECTION 413 - BRIDGE DECKS AND CONCRETE OVERLAYS

- SECTION 415 - MANUFACTURE AND ERECTION OF PRECAST AND PRESTRESSED CONCRETE MEMBERS
- SECTION 416 - MANUFACTURE AND INSTALLATION OF POST-TENSIONED CONCRETE MEMBERS
- SECTION 418 - CONCRETE BRIDGE DECK SEALANTS - SILANE SURFACE TREATMENT OF NEW PORTLAND CEMENT CONCRETE
- SECTION 419 - CONCRETE BRIDGE DECK WATERPROOFING SYSTEM - PREFABRICATED MEMBRANE
- SECTION 421 - STRUCTURAL STEELWORK
- SECTION 422 - MISCELLANEOUS STEELWORK
- ~~SECTION 501 - HOT MIXED ASPHALT PAVEMENT (**DELETED**)~~
- SECTION 502 - ASPHALT PAVEMENT CONSTRUCTION (EPS) (**REVISED SECTION**)
- SECTION 503 - BASE PREPARATION AND BASE PROCESSING
- SECTION 504 - PAVEMENT DRAINAGE
- SECTION 507 - PRODUCTION AND STOCKPILING OF ASPHALT MIX
- SECTION 508 - GRADED AGGREGATE SEAL COAT (EPS)
- SECTION 511 - COLD MILLING
- SECTION 514 - HOT IN-PLACE RECYCLE
- SECTION 515 - HOT-IN-PLACE RECYCLED ASPHALT PAVEMENT (EPS)
- SECTION 521 - ASPHALT STABILIZED BASE COURSE MIXED IN PLACE
- SECTION 531 - ASPHALT SURFACE TREATMENTS
- SECTION 536 - PAVEMENT CRACK SEALING
- SECTION 541 - RUBBLE MASONRY
- SECTION 582 - CONCRETE CURB AND GUTTER AND STORM DRAINAGE
- SECTION 586 - PLANT MIXED PORTLAND CEMENT TREATED BASE COURSE

SECTION TITLES

VOLUME TWO CONTAINS THE FOLLOWING SECTIONS:

- SECTION 604 - STEEL TRAFFIC BARRIER CONSTRUCTION
- SECTION 635 - ELECTRICAL AND SIGNING
- SECTION 700 - WILDLIFE EXCLUSION FENCING (**NEW SECTION**)
- SECTION 741 - FENCE CONSTRUCTION
- SECTION 751 - TOPSOIL AND LANDSCAPE GRADING
- SECTION 754 - PLANTING OF TREES, SHRUBS, AND GROUND COVERS
- SECTION 757 - REVEGETATION SEEDING
- SECTION 766 - IRRIGATION
- SECTION 769 - PROTECTION AND RETENTION OF VEGETATION
- SECTION 903 - TIMBER - MATERIALS
- SECTION 904 - TIMBER (TREATED AND UNTREATED) - FABRICATION AND HANDLING
- SECTION 905 - TIMBER - GLUED LAMINATED
- SECTION 906 - ROUND TIMBER PILES
- SECTION 908 - PRESERVATIVE TREATMENT - WOOD PRODUCTS
- SECTION 909 - TREATED WOOD FENCE POSTS
- SECTION 911 - STEEL AND IRON
- ~~SECTION 913 - REINFORCEMENT FOR CONCRETE (**DELETED**)~~
- SECTION 917 - WIRE ROPE
- ~~SECTION 931 - PORTLAND CEMENT (**DELETED**)~~
- SECTION 933 - ADMIXTURES FOR PORTLAND CEMENT CONCRETE
- SECTION 941 - PRECAST REINFORCED CONCRETE BARRIERS
- SECTION 951 - ASPHALT AND PAVING MATERIALS FOR HIGHWAY USE
- SECTION 952 - CONTRACTOR SUPPLY ASPHALT AND PAVING MATERIALS FOR HIGHWAY USE
- SECTION 971 - PLASTIC TRAFFIC CONES
- SECTION 991 - CALCIUM CHLORIDE AND SODIUM CHLORIDE

THIS PAGE IS LEFT INTENTIONALLY BLANK

SECTION 101

QUALITY MANAGEMENT

101.01 General – All work on Ministry projects shall be undertaken through a total quality management process, utilizing Ministry, Contractor and third-party resources, as necessary.

The Ministry accepts the following definitions associated with Quality Management:

- **Quality Control (QC):** The process of checking specific product or service results to determine if they comply with relevant quality standards and identifying ways to eliminate causes of unsatisfactory product or service performance.
- **Quality Assurance (QA):** The process of evaluating overall product or service, by persons or companies independent of those doing the Work, on a regular basis to provide confidence that the product or service satisfies the relevant quality standards.

The quality management program has two key components as follows:

- Quality Control – the Contractor’s responsibility
- Quality Assurance – the Ministry’s responsibility

Each component of the program must address materials, processes, products, and documentation.

The Contractor shall provide unrestricted access to all Quality Control operations and documentation produced by or on behalf of the Contractor and shall allow the Ministry full access at any time during working hours.

The Ministry Representative will review the Contractor’s performance of the Work and determine the acceptability of the Work based on the Ministry’s Quality Assurance results and, where deemed appropriate by the Ministry Representative, supplemented by the Contractor’s Quality Control results.

Work failing to meet the conditions of the Contract shall be considered Unacceptable Work.

The Ministry Representative may consider all Work from the last acceptable Quality Assurance testing as Unacceptable Work. The Contractor shall not be entitled to payment for Work that lacks the appropriate Quality Control documentation, verified by the QC Manager, as required by the Contract.

The Contractor shall implement a well-coordinated approach to all operations related to the Work and will organize its team and operations in keeping with the goal of doing things right the first time.

101.02 Quality Control Plan (QC Plan)

101.02.01 QC Plan General Requirements – The Contractor shall be responsible for all Quality Control during the performance of the Work. QC work includes monitoring, inspecting and testing the means, methods, materials, workmanship, processes and products of all aspects of the Work as necessary to ensure conformance with the Contract.

The Contractor shall prepare a Quality Control Plan (QC Plan) in accordance with the Contract provisions and shall submit the complete QC Plan to the Ministry Representative a minimum of two weeks in advance of commencement of any element of Work covered by the plan.

The QC Plan shall be structured around the ISO 9001:2000 program (although ISO registration is not required), and clearly demonstrate the Contractor’s understanding and commitment to ISO’s eight principles of quality management:

- Customer focused organization
- Leadership
- Involvement of people
- Process approach
- System approach to management
- Continual improvement
- Factual approach to decision-making
- Mutually beneficial supplier relationships.

The QC Plan must also include sections detailing the Contractor’s methodology associated with each of the relevant sections of ISO 9001:2000 as listed in Table 101-A.

No Work shall be undertaken on any element of Work (including payment Items and incidental Work, or submittals for review) for which there are QC Plan submission requirements until the Ministry has accepted the base portion of the QC Plan and the specific details for that element of Work.

Subject to the submission requirements outlined in SS 101.02.03, the QC Plan is required to cover the Work in its entirety, including without limitation all materials the Contractor and Subcontractors are supplying, and all items and phases of construction on the Project.

The plan may be operated wholly or in part by a qualified Subcontractor or an independent agency/organization. However, the plan’s administration (including

SECTION 101

QUALITY MANAGEMENT

conformance with the plan and its modifications) and the quality of the Work remain the responsibility of the Contractor.

The Contractor's QC program and the Work shall be undertaken in accordance with the QC Plan and shall be well managed, with testing results representative of actual operations. Results will be reported accurately and in a timely manner.

Table 101-A: ISO Section Headings

§	ISO 9001:2000 Section Heading
4	Quality Management System
4.1	General Requirements
4.2	Documentation Requirements
5	Management Responsibility
5.1	Management commitment
5.2	Customer focus
5.3	Quality policy
5.4	Planning
5.5	Administration:
5.6	Management review:
6	Resource Management
6.1	Provision of resources
6.2	Human resources
6.3	Facilities
6.4	Work environment
7	Product Realization
7.1	Planning of realization processes
7.2	Customer-related processes
7.3	Design and/or development:
7.4	Purchasing
7.5	Production and service operations
7.6	Control of measuring and monitoring devices
8	Measurement, Analysis and Improvement
8.1	Planning
8.2	Measurement and monitoring
8.3	Control of nonconformity
8.4	Analysis of data
8.5	Improvement

The Contractor shall also ensure that all workers are familiar with the Quality Management Plans, its goals, and their role under it, as well as with the Contract specifications associated with the Work they are to undertake.

101.02.02 QC Plan Quality Control Staff and Equipment Submission Requirements – The Contractor shall provide all resources and take all actions necessary to ensure:

- Provision of sufficient inspection or testing staff, with adequate equipment and technical support to perform all Quality Control functions in an accurate and timely manner.
- That QC staff perform only inspections and tests for which they are qualified.
- All testing equipment is calibrated, properly maintained, and in good operating condition.
- All testing and inspection is performed in accordance with appropriate standards of the Contract.
- Submission to the Ministry Representative, within twenty-four (24) hours, of daily reports for all tests and inspections that indicate non-conformance of the material being tested.
- Production, within forty-eight (48) hours, of daily reports for all tests and inspections that indicate conformance of the material being tested and the availability of back-up documentation to substantiate test results when required.
- Organization, compilation and submission of all project QC documentation within 14 days of the last day on Site and as a condition precedent to the issuance of the Completion Certificate.

The Contractor shall designate one person as the Quality Control Manager (QC Manager) who shall be responsible for the implementation of the QC Plan. The QC Manager shall be a qualified Professional Engineer, Certified Engineering Technician, or Applied Science Technologist, or other person with knowledge, skills and abilities acceptable to the Ministry Representative.

The QC Manager shall be at arms length from the productivity part of the Contractor's organization and specifically shall not be the Project Manager or the Project Superintendent. On Minor Works contracts, this requirement will, upon request by the Contractor and where the candidate is deemed acceptable under the foregoing paragraph, generally be waived by the Ministry Representative.

The Ministry recognizes the Contractor's Project Manager and Superintendent as the personnel responsible for making the product meet the contractual requirements, but the QC Manager's duties include being responsible to

SECTION 101

QUALITY MANAGEMENT

measure conformance and to ensure that quality is not compromised by production pressures.

The QC Manager, or a designated replacement acceptable to the Ministry Representative empowered and able to perform all of the QC Manager's relevant duties, shall remain on Site at all times the Contractor is performing Work which must be tested or inspected in-process, and must be readily accessible and able to return when off-Site.

The QC Plan will include the following information:

- the name of the QC Manager and qualifications establishing a proven capability to provide the specific services required for the Project;
- the name of QC testing agencies and their proven capability to provide the specific services required for the Project;
- a listing of QC staff (including names, qualifications and relevant experience) and their assigned roles and work scheduling in performing QC duties;
- a list of testing equipment to be used for the Work.

The QC Plan must include an organizational chart showing details of the flow of information, "hold" points, rectification of deficiencies and other relationships and responsibilities necessary to assure Project quality requirements are met.

The QC Plan should describe how the QC staff are allocated to Project requirements, the tasks assigned to each, and how their work will be coordinated.

Without limitation, the Contractor's QC Manager shall:

- implement the Contractor's QC Plan;
- be responsible for measuring conformance with all aspects of the contract quality;
- stop work when materials, product, processes or submittals are deficient;
- develop inspection and testing plans for each element of Work;
- develop acceptance/non-acceptance reports and quality control checklists for each element of Work in sufficient detail to gauge conformance with all significant contractual requirements;
- ensure the requirements for quality management (including an overview of how the QC Plan operates, the worker's role in it, contractual specifications for the Work, and work procedures) are known to, understood by, and adhered to by all workers on the Site;
- ensure that all QC checklists are signed-off by competent and responsible parties as close to the

actual work as appropriate to the nature of the Work (e.g. by the actual worker or a foreman for most work; by a Professional Engineer for false work erection; etc.)

- review, sign, and be responsible for all reports (materials and testing results);
- consult with field inspectors regarding materials and testing issues;
- receive notification by inspectors re deficiencies and ensure re-testing or rejection;
- provide weekly and monthly summary reports on testing and inspection results;
- initiate the non-conformance process when materials or product do not meet the required specifications and, inform the Ministry Representative of such non-conformance;
- consult with the Contractor Representative and initiate corrective action on non-conformance;
- respond to each Non-Conformance Report (NCR) issued by the Ministry Representative within the time specified in the NCR;
- schedule testing and inspection services in coordination with the Contractor's superintendent and foremen;
- monitor QC testing and inspection procedures including those of the Subcontractors;
- work directly with the Ministry Representative on matters related to QC;
- ensure required approvals and permits from the Ministry Representative and others are obtained as and when required;
- verify that all testing equipment is properly maintained and kept in good working order;
- keep an organized filing system to ensure that quality records are easily accessible so that auditors can obtain necessary information;
- review issued for construction drawings, calculations, and shop drawings and ensure that all concerned Contractor staff have current versions of documents applicable to their part of the Work;
- notify the Ministry Representative of any changes in survey layout, location, line, grade, etc., for approval; notify the company principles of any issues that compromise the integrity or function of the Quality Management System, and
- provide an auditable trail for survey computations to the Ministry Representative.

101.02.03 QC Plan Submission Requirements (Contract-Specific) – Each QC Plan submission to the Ministry shall be accompanied by a QC checklist prepared by the Contractor demonstrating that the submission has been checked for compliance with contractual requirements.

(i) Full Submission

Unless otherwise specified in the Special Provisions, the Contractor's QC plan shall provide details of the means, methods, and frequencies of Quality Control measures for all elements of Work (whether payment Items or incidental) in the Contract.

(ii) Partial Submission

On projects considered by the Ministry to be of low complexity and/or risk, and only where explicitly invoked by the Special Provisions, the Ministry will accept a partial QC Plan submission.

Notwithstanding any such reduced submission requirements, the Contractor remains responsible for QC for all aspects of the Work.

The Contractor's partial QC Plan submission to the Ministry Representative is only required to address the details of the following types of Work:

- Traffic Management
- Survey/layout
- Materials incorporated into the Work (concrete barrier, culverts, filter cloth, lock-blocks, etc.)
- Compaction (subgrade, embankments, granular aggregates, culvert backfill, etc.)
- Aggregate gradation
- Plus any other elements identified in the Special Provisions as a submission requirement.

The Contractor shall initiate such other Quality Control procedures as are necessary for ensuring the production of a quality product and may include them in the Quality Control Plan submission.

(iii) For Both Full and Partial Submissions

The initial QC Plan shall be submitted to the Ministry Representative a minimum of seven (7) days in advance of the Project pre-construction meeting and must provide details of all elements of Work anticipated to be undertaken within the Contractor's first thirty (30) days on Site.

Detailed submissions for the balance of the Work must be received a minimum of seven (7) days prior to the anticipated first day of Work on each element covered by the submission.

The initial submission, as well as any subsequent submission or revision, must be accompanied by the Contractor's QC checklist for Quality Management, verifying that the submission meets all relevant contractual requirements.

Improved procedures may be introduced after the start of work as necessary as amendments to the Quality Control Plan. All amendments require the written acceptance of the Ministry Representative.

The type and frequency of QC tests shall be established by the Contractor and shall be in conformance with the requirements of the Contract, including the minimum frequencies specified in the Special Provisions and/or Standard Specifications (for those listed items applicable to the Work), and the current acceptable practice of the industry.

When materials or equipment are specified by standard or performance specifications the Contractor shall obtain from suppliers or manufacturers independent test reports, or test certificates stating that the materials or equipment meet or exceed specified requirements. The Contractor shall provide back-up documentation of actual testing results upon request by the Ministry Representative.

101.03 Quality Assurance Plan – The Ministry will prepare and implement a Quality Assurance Plan, based in part on the effectiveness and reliability of the Contractor's Quality Control Plan. The Ministry may also undertake random and systematic inspections of the Work and of the Contractor's QC documentation.

The purpose of the QA Plan and inspectional activities is to ensure that payment is made only for acceptable works in place, and may be based on a limited amount of sampling and testing.

The Ministry Representative will monitor the Contractor's operations and the Quality Control program to assure that standards are being met and to assess what payments have been earned under the terms of the Contract.

Any instances of Unacceptable Work discovered will result in a Non-Conformance Report being issued to the Contractor.

The QA program activities will not relieve the Contractor of Quality Control responsibilities under the terms of the Contract.

The frequency of QA inspection and testing will generally be approximately zero to ten percent (0 – 10%) of the frequencies undertaken by the Contractor in its QC Plan and will initially be set at a level commensurate with the Ministry Representative's confidence in the anticipated effectiveness of the Contractor's QC program.

The Ministry Representative may increase or decrease the frequency of QA inspection and testing during the course

of the Work, based in part on the actual effectiveness of the Contractor's QC Plan.

101.04 Quality Audit – The Ministry may have one or more auditors on the Project, supplementing the work of the Ministry QA staff. When utilized, the auditor(s) will report to the Ministry Representative and provide a systematic and independent assessment of whether or not the materials and Project activities and related results comply with the Contract, the Contractor's QC Plan, and the Ministry's QA Plan. These auditors may be Ministry employees but will be assigned from resources which have not otherwise been involved with the Work.

The objective of Quality Auditing is to have an independent opinion on both QC and QA activities and be proactive in avoiding or reducing quality related issues by requiring the process of conformance verification to be systematic.

The auditor(s) will be allowed unrestricted access to the Site and all activities therein, to all testing and documentation of the work done by the Ministry, Contractor and their agents and suppliers.

101.05 Non-Conformance Reports (NCRs) – The Contractor shall and the Ministry may review the Work to determine conformance with the contractual requirements.

Non-conformances found shall be dealt with as follows.

101.05.01 Contractor's Internal NCR – Should the Contractor's QC reporting indicate that the Work is not in conformance, the QC Manager shall issue an internal Non-Conformance Report (NCR) to the Contractor, with a copy to the Ministry, including a response time.

The Contractor shall then respond to the QC Manager, with a copy to the Ministry Representative, with respect to the NCR, within the specified time, with proposed resolutions and corrective actions. The Contractor and/or the QC Manager may consult with the Ministry Representative on the resolutions but is not required to do so.

Payment for a Quality Management will not be affected by internal NCRs, as long as the issue is diligently pursued and resolved.

Payment for the Work itself may be withheld until the NCR issue is resolved.

101.05.02 Ministry-Issued NCR – Should the Ministry's QA reporting indicate that the Work is not in conformance, the Ministry Representative will issue to the Contractor a NCR, including a response time.

The Contractor shall then respond to that NCR, within the specified time, with proposed resolutions and corrective actions.

The Ministry Representative will accept or reject the proposed resolution and corrective action proposal.

Assurance testing and inspection will be performed to determine if the corrective action has provided an acceptable product. Acceptance and rejection will continue until the Ministry Representative determines that a quality product has been achieved.

A portion of the payment for a Quality Management may be withheld until the NCR issue is resolved or, in accordance with SS 101.07, may be withheld permanently.

Payment for the Work itself may be withheld until the NCR issue is resolved.

101.05.03 Opportunity for Improvement – Should the QA review indicate that the Work is not in conformance, but the variance is deemed minor by the Ministry Representative, the Ministry Representative may issue an Opportunity for Improvement (OFI) report.

The Contractor is encouraged to review the findings and undertake such modifications to the QC Plan and the work procedures as necessary to address the issue.

An OFI will not affect payment for Quality Management or for the Work itself.

101.06 Appeal – If the Contractor disputes the validity of a finding in an NCR, the Contractor may file an appeal with the Ministry Representative. The Ministry Representative and the Contractor Representative will use all reasonable efforts to refine the area of dispute and to resolve the determination of conformance with the Contract.

If the Ministry Representative and the Contractor Representative cannot come to a mutually agreeable resolution, the Work that is the subject of the Non-Conformance Report shall be re-evaluated by an independent third-party, selected by the Ministry Representative in consultation with the Contractor, at a test frequency equivalent to twice that specified in the Contract or to such other frequency as may be mutually agreed between the Ministry Representative and the Contractor.

If the appeal testing confirms the non-conformance determination, all appeal testing costs will be borne by the Contractor. If the appeal testing shows that the Work did in fact meet the requirements of the Contract, all appeal testing costs will be borne by the Ministry.

101.07 Payment – The Lump Sum Price bid for Quality Management shall be full compensation for all costs resulting from the Quality Management requirements set out in the Contract.

Payment will be made on a monthly basis prorated for the percentage of the total Work completed as determined by the Ministry Representative, subject to the Contractor

SECTION 101

being totally compliant with the requirements of this Section and with its own Quality Control Plan.

The Ministry Representative may deduct an amount from any monthly payment so computed, for any quality management work required but not satisfactorily undertaken during that month. The Ministry Representative may also reduce the total Lump Sum payable by the value of any quality management work required but not satisfactorily undertaken during the Term of the Contract. The foregoing determinations will be made in the sole discretion of the Ministry Representative.

QUALITY MANAGEMENT

Inspection or testing by the Ministry Representative will be at the Ministry's cost. However, re-inspection or re-testing by the Ministry for repaired deficient details shall be at the Contractor's cost.

Work that is deemed unacceptable in accordance with SS 101.01 will not be eligible for payment from the applicable Item for that Work.

The Completion Certificate will not be issued if there are any unresolved Non-Conformance Reports.

SECTION 108

SAMPLE FORMS

PART A – GENERAL

108.01 General -This Section provides sample copies of forms which the Contractor may be required to execute and submit to the Ministry in accordance with the Contract. Blank copies of these forms are available from the Ministry Representative.

PART B – STATUTORY DECLARATIONS

108.11 Major Works – Final Progress Payment – The form attached as Appendix “A” (Ministry form H0394A) is used to meet the Statutory Declaration requirements of the Major Works General Conditions where the final

progress payment is to be paid by the Ministry to the Contractor.

108.12 Major Works, Minor Works and Operational Services – Holdback or Security Release – The form attached as Appendix “B” (Ministry form H0394F) is used to meet the Statutory Declaration requirements of the Major Works or Minor Works General Conditions or the Operational Services Contract where holdback amounts or security (in a form other than a bond) are to be released by the Ministry either on an interim or final basis upon Substantial Completion or total completion.

APPENDIX A – MAJOR WORKS – FINAL PROGRESS PAYMENT

IN THE MATTER OF THE EVIDENCE ACT, 1996 RSBC c.124 AND IN THE MATTER OF CERTAIN DISBURSEMENTS TO BE MADE IN CONNECTION WITH THE CONTRACT

dated the _____ day of _____, _____ between:

**HER MAJESTY THE QUEEN IN RIGHT OF THE PROVINCE OF BRITISH COLUMBIA,
AS REPRESENTED BY THE MINISTER OF TRANSPORTATION**

(the Province)

and:

(the Contractor)

pertaining to Project Number _____ Contract ID _____
the "Project" the "Contract"

I, _____, being a
(PRINT OR TYPE FULL NAME AND POSITION OR TITLE)

duly authorized representative of and agent for the Contractor on the Project do solemnly declare and attest that,

- all of the Contractor's obligations under the Contract arising as of this date have been performed;
- all accounts for labour, subcontracts, products, materials, construction machinery, equipment and any other indebtedness and obligations which may have been incurred by the Contractor in connection with the Project and/or the Contract up to the date the immediately preceding progress estimate have been paid in full or remain in good standing; and
- I have the knowledge and information and have conducted all such enquiries necessary to enable me to make this statutory declaration.

I MAKE THESE SOLEMN DECLARATIONS, conscientiously believing them to be true and knowing that they are of the same legal force and effect as if made under Oath.

DECLARED BEFORE ME AT THE

_____ of _____, in the

Province of British Columbia, on this

_____ day of _____, _____

A Commissioner for taking Affidavits for British Columbia

Signature of Contractor's Authorized Representative

APPENDIX B – HOLDBACK / SECURITY RELEASE



Ministry of
Transportation

STATUTORY DECLARATION

IN THE MATTER OF THE EVIDENCE ACT, 1996 RSBC c.124 AND IN THE MATTER OF CERTAIN DISBURSEMENTS MADE IN CONNECTION WITH THE CONTRACT

dated the _____ day of _____, _____ between:

**HER MAJESTY THE QUEEN IN RIGHT OF THE PROVINCE OF BRITISH COLUMBIA,
AS REPRESENTED BY THE MINISTER OF TRANSPORTATION
(the Province)**

and:

(the Contractor)

pertaining to Project Number: _____ the "Project" Contract ID _____ the "Contract"

I, _____, being the
(PRINT OR TYPE FULL NAME AND POSITION OR TITLE)

duly authorized representative of and agent for the Contractor, solemnly declare and attest that:

- all of the Contractor's obligations under the Contract have been performed as of this date; and
- I have the knowledge and information and have conducted all such enquiries necessary to enable me to make this statutory declaration.

I MAKE THIS SOLEMN DECLARATION, conscientiously believing it to be true and knowing that it is of the same legal force and effect as if made under Oath.

DECLARED BEFORE ME AT THE _____)

of _____, in the _____)

Province of British Columbia, on this _____)

_____ day of _____, _____)

A Commissioner for taking Affidavits for British Columbia)

Signature of Contractor's Authorized Representative

THIS PAGE IS LEFT INTENTIONALLY BLANK

SECTION 125

VALUE ENGINEERING - PROPOSAL GUIDELINES

125.01 Definitions

125.01.01 VEP means a value engineering proposal which has been set out in writing by the Contractor to the Ministry in accordance with these guidelines.

125.01.02 Summary VEP means a brief summary of a VEP, including the anticipated cost and timing of developing the VEP, submitted by the Contractor to the Ministry.

125.01.03 Implemented VEP means a value engineering proposal which has been accepted and implemented by means of a Supplemental Agreement or Work Order.

125.01.04 Net Cost Savings means an amount determined by the Ministry on the basis of the Contract Price before implementation of the VEP minus the adjusted Contract Price determined after the implementation of the VEP less the following costs, which are subject to negotiation:

- a) the Contractor's costs of developing the VEP.
- b) the Ministry's costs of evaluating the VEP.
- c) the anticipated additional administration and project management costs to the Ministry resulting from the implementation of the VEP.

125.01.05 Value Engineering Incentive means an amount calculated pursuant to written agreement between the Ministry and the Contractor, which will generally be equal to 50 percent of the Net Cost Savings realized by the Ministry due to the implementation of the VEP.

125.02 Guiding Principles for VEP Evaluation

125.02.01 To be considered, a VEP must be perceived by the Ministry to provide a tangible benefit to the Ministry, such as:

- a) a reduction in the total cost of the Project; or
- b) an improvement to the product which the Ministry expects will reduce the life cycle costs; or
- c) a change in the Construction Schedule which will be beneficial to the Ministry; or
- d) a reduction or transfer of risk which will benefit the Ministry;

and should result in a product which is functionally equal or superior to that which would result in the absence of the VEP.

125.02.02 A VEP should not:

- a) impair the functionality and characteristics of the Project, including, but not limited to, the service life,

economy of operation, ease of maintenance, aesthetic considerations, preliminary engineering commitments, or design and safety standards.

b) be similar to a change in the Drawings or specifications under consideration by the Ministry for the Work at the time the VEP is submitted to the Ministry.

c) increase the anticipated life cycle costs of the Project.

125.02.03 To be eligible for a Value Engineering Incentive, a VEP must propose a change to the Work which meets the same constraints, assumptions and considerations as those which governed the original design of the Work, as it is defined in the Agreement. Where Changed Conditions, or other changes, have occurred and have already created the need for a Change To Work, a VEP which responds to this need will not normally be eligible for a Value Engineering Incentive, and in any case will be eligible only for a reduced incentive.

125.02.04 A VEP may involve:

- a) a material or product substitution.
- b) a change to the Work method.
- c) a Work sequencing change, including changes to traffic routing or detour sequences, changes to structure or roadway construction sequences.
- d) a change to the design or engineering of the Project which provides a marked departure from the product as defined in the Contract Document Package.

125.03 Value Engineering Proposal Submissions

125.03.01 Prior to presenting a VEP, the Contractor will prepare a Summary VEP and submit it to the Ministry for consideration.

125.03.02 The Ministry will evaluate the Summary VEP and will advise the Contractor whether or not the Ministry would be willing to consider, without obligation, the VEP described in the Summary VEP.

125.03.03 A VEP should contain the following information:

- a) a statement that the proposal is submitted as a VEP.
- b) a detailed description of the VEP and the manner in which the VEP should be implemented (by Supplemental Agreement or Work Order).
- c) a detailed description of the Items and quantities, Drawings, specifications, designs, Completion Date, Milestone Dates or other elements under the

SECTION 125

VALUE ENGINEERING - PROPOSAL GUIDELINES

Agreement which would be changed, altered, modified or replaced by the implementation of the VEP.

d) plans and working drawings needed to analyze the VEP and determine the impact of the VEP on the Project.

e) an itemized cost analysis of the Net Cost Savings.

f) the date, which must be not less than two weeks after the date of the VEP, by which the VEP must be implemented in order to maximize the cost reduction during the remainder of the Agreement.

125.03.04 Any request by the Contractor for substitution of material or method will only be considered if submitted as a VEP.

125.04 Implementation of a VEP

125.04.01 For those VEPs approved by the Ministry, the Ministry Representative will prepare a Supplemental Agreement or a Work Order which will set out the Net Cost Savings, the Change To Work required to realize the Net Cost Savings, and the adjustment to the Contract Price(s) and payment terms resulting from the VEP, in accordance with these guidelines.

125.04.02 The Ministry will retain the right to utilize a VEP, or part thereof that has been accepted for the Project, on any other or subsequent projects without any obligation to the Contractor, unless the Contractor has provided written notice in the Summary VEP and the VEP regarding patented materials or processes involved in the VEP.

SECTION 135

CONSTRUCTION SITE SAFETY

135.01 General – This Section describes the responsibilities of the Contractor for safety on the Site.

Virtually every Ministry project will occur on a “multiple employer worksite”, by virtue of the Contractor retaining Subcontractors, by the Ministry having retained other independent contractors to work on or near the Site, by the Ministry Representative having forces on-Site, or through utilities, municipalities or other entities performing work on the Site.

Under the Workers Compensation Act and Regulation, each of these parties has responsibilities as an “employer” and may have responsibilities as a “prime contractor” for other employers working on the Site.

In any area where the operations of the various parties overlap or otherwise affects the others, one of those parties will be designated by the Ministry as the Prime Contractor, and, as laid out in this Section and the Workers Compensation Act and Regulation, will have responsibility for the overall co-ordination of safety in that Area of Responsibility.

Where the Contractor takes on the role of Prime Contractor, it continues to have the responsibilities of the Contractor and adds those of the Prime Contractor, each as described in this Section.

Where the Contractor is not the Prime Contractor but is working on a Site which is under the co-ordination of a Prime Contractor designated by the Ministry they will be responsible for co-operating with the Prime Contractor as described in this Section.

The distinction between the geographic areas of the “Site” (where the Contractor is to build something under the terms of the Contract) and the “Area of Responsibility” (where the Contractor or another party is responsible for health and safety issues) is important.

135.02 Definitions – In this Section, except as otherwise expressly provided herein:

a) Adjacent or Nearby Worksite is a multiple employer workplace described by another Ministry contract, or in a written notice that may be issued by a Ministry Representative, and/or as described in a Notice of Project, for which another party has been engaged as prime contractor but which may be entered for the purposes of the Contract by the Workers, Suppliers and Subcontractors of the Contractor.

b) Area of Responsibility means the Multiple Employer Workplace so designated in writing by the Ministry, comprised of the Site including additional area(s) outside the Site or excluding area(s) within the Site, which is to be reflected in the Notice of Project.

c) Base Safety Program means the occupational health and safety program that the Prime Contractor will initiate and maintain, as described in this Section.

d) Employer means an employer as defined in the Workers Compensation Act, and includes the Contractor.

e) Joint Committee means the joint health and safety committee that shall be established and maintained by the Prime Contractor in compliance with the Workers Compensation Act and the Regulation, (see also “Other Joint Committees”)

f) Multiple Employer Workplace means, in accordance with the Workers Compensation Act and the Regulation, a workplace where workers of 2 (two) or more Employers are working at the same time, and includes the Site and any Area of Responsibility.

g) Notice of Project means the notice of project described in the Regulation.

h) Notice of Unsafe or Harmful Condition or Act means the written notice that the Contractor will deliver to any Employer pursuant to SS 135.06, in the form set out in Appendix A of this Section.

i) Other Joint Committees means additional committees that may be established by the Contractor in compliance with the Workers Compensation Act and the Regulation.

j) Other Persons means any person or persons, other than Workers working on the Project, who, for whatever reason or purpose, are on the Site or Area of Responsibility.

k) Prime Contractor means a prime contractor as defined in the Workers Compensation Act.

l) Qualified Coordinator means the person, who meets the qualifications of a qualified coordinator described in the Regulation, and who is appointed by the Prime Contractor to discharge for the Area of Responsibility, the responsibilities of a qualified coordinator as described in the Workers Compensation Act and the Regulation.

m) Qualified Person means the person who meets the qualifications of a qualified person described in the Workers Compensation Act and the Regulation, and who is designated by the Contractor to discharge for the Site the responsibilities of a qualified person as described in the Workers Compensation Act and the Regulation.

n) Regulation means the British Columbia Regulation 296/97 entitled *Occupational Health and Safety Regulation* prescribed under the Workers Compensation Act, as amended from time to time.

o) Workers means the employees, workers, servants, agents or invitees of Employers, including of the Contractor, at the Site.

SECTION 135

CONSTRUCTION SITE SAFETY

p) Workers Compensation Act means the Workers Compensation Act, R.S.B.C. 1996, c.492 as amended from time to time.

q) Workers' Compensation Board means the Workers' Compensation Board constituted under the Workers Compensation Act.

135.03 Ministry

135.03.01 Subject to SS 135.03.02 to SS 135.03.04, the Ministry designates the Contractor to be the Prime Contractor for the Site.

135.03.02 The Ministry may designate one or more Areas of Responsibility, each with a single Prime Contractor.

135.03.03 The Ministry may, in its sole discretion, appoint in writing:

- a) the Contractor,
- b) a party other than the Contractor, or
- c) the Ministry

to be the Prime Contractor for one or more Areas of Responsibility and will notify the Contractor in writing of that designation.

135.03.04 The Ministry may at any time, in its sole discretion and in writing, change or revoke any designation of the Prime Contractor or Area of Responsibility.

135.03.05 Any designation made pursuant to SS 135.03.02 to SS 135.03.04 will include:

- a) a description of the geographic Area of Responsibility, and
- b) the time and date that the designation comes into effect.

135.03.06 Receipt and retention by the Ministry of the information and documentation listed in this Section in no way constitutes approval of or authorization of the form, content or adequacy of such information and documentation on the part of the Ministry.

135.04 Prime Contractor

135.04.01 Acknowledgement of Assignment as Prime Contractor – Upon notification of such appointment, the Contractor shall deliver written confirmation to the Ministry of its acknowledgement to being the Prime Contractor for the Area of Responsibility.

135.04.02 Prime Contractor Responsibilities – The Prime Contractor shall, for each assigned Area of Responsibility:

- a) ensure that all required Notice of Project forms have been prepared, accurately reflect the Area of Responsibility and Prime Contractor assignment, and are posted within the Area of Responsibility,
- b) at the sole cost of the Prime Contractor, provide, post and maintain 2 (two) signs, in accordance with the

specifications, which contain the informational messaging stipulated in Drawing SP135-01 of this Section, at locations satisfactory to the Ministry Representative,

c) appoint and maintain a Qualified Coordinator, meeting the qualifications of a “qualified coordinator” as described in the Workers Compensation Act and the Regulation, and notify the Ministry Representative and all Employers working within the Area of Responsibility of any changes to the appointment. The duties of the Qualified Coordinator include:

- (i) to perform the functions of the “qualified coordinator” as described in the Regulation,
- (ii) to ensure the coordination of health and safety activities for the Area of Responsibility, including establishing Joint Committees and holding meetings and maintaining records thereof,
- (iii) ensure all Employers and Workers are informed of hazards created, and
- (iv) ensure that the hazards are addressed throughout the duration of the work activities,

d) ensure all other Employers designate and at all times maintain not less than one Qualified Person to be responsible for the Employer’s health and safety activities connection with the Work, including administering the Base Safety Program,

e) Ensure periodic crew safety meetings are held, and minutes kept, to inform the Workers of any known or reasonably foreseeable risks on the Area of Responsibility and the actions to be taken to eliminate or minimize those risks,

f) create, implement and maintain a system to provide up-to date information, available in the Area of Responsibility, relating to health and safety activities, including without limiting the generality of the foregoing:

- (i) the name of the Qualified Coordinator,
- (ii) a site drawing showing the project layout, first aid locations, emergency transportation provisions and the evacuation marshalling station,
- (iii) a set of construction procedures designed to protect the health and safety of Workers,
- (iv) ensuring safe access for delivery of equipment and material,
- (v) identifying foreseeable and known hazards,
- (vi) ensuring Employers notify the Prime Contractor of undertakings likely to create a hazard,
- (vii) communicating hazards to Employers and Workers,
- (viii) ensuring regular inspections are carried out,

- (ix) ensuring occupational health and safety orientation to all Workers,
 - (x) ensuring Employers hold site safety or toolbox meetings,
 - (xi) ensuring Employers report incidents promptly to the Prime Contractor, and
 - (xii) ensuring incidents are reviewed.
- g) create and maintain an Emergency Response Plan for the Area of Responsibility, ensuring that it:
- (i) is communicated to all persons working in the Area of Responsibility,
 - (ii) addresses work after regular hours, and
 - (iii) addresses first aid services including
 - supplies, equipment, and facilities
 - a system of transportation of injured persons to medical treatment
 - first aid coordination after regular working hours,
- h) follow the Notice Process specified in SS 135.06 whenever an unsafe or harmful condition or act occurs in the Area of Responsibility or on an Adjacent or Nearby Worksite,
- i) when requested by the Ministry Representative, shall prepare and provide a statistical summary, in the form provided in Appendix B of this Section, of all health and safety records applicable to the Area of Responsibility and covering the period requested by the Ministry Representative, and
- j) immediately notify the Ministry Representative of the occurrence of any accident that:
- (i) resulted in serious injury to or the death of a worker,
 - (ii) involved a major structural failure or collapse of a building, bridge, tower, crane, hoist, temporary construction support system or excavation,
 - (iii) involved the major release of a hazardous substance, or
 - (iv) was an incident required by the Regulation to be reported.

135.04.03 Base Safety Program – Notwithstanding the limitation relating to the requirement for initiating and maintaining an occupational health and safety program set out in the Regulation, the Prime Contractor will initiate and at all times maintain at the Area of Responsibility the Base Safety Program which will be designed to prevent injuries and occupational diseases within the contemplation of the Workers Compensation Act and the Regulation, describe how the Prime Contractor will meet

the requirements of SS 135.04.02 and, without limiting the generality of the foregoing, will describe how the Prime Contractor will ensure that:

- a) the requirements of an occupational health and safety program as stipulated in the Workers Compensation Act and Regulation will be satisfied, including the establishment and maintenance of a Joint Committee,
- b) the activities of all Employers, Workers and Other Persons at the Area of Responsibility and relating to occupational health and safety will be coordinated,
- c) reasonably practicable measures are taken to establish and maintain a system or process to ensure compliance with the Workers Compensation Act and the Regulation in respect of the Area of Responsibility,
- d) the Prime Contractor, all Workers, Employers, and Other Persons are made aware of all known or reasonably foreseeable health and safety hazards to which they may be exposed on the Area of Responsibility and are instructed in the terms of the Workers Compensation Act and the Regulation,
- e) complete and accurate reports, records and documents relating to occupational health and safety activities at the Area of Responsibility, or related to the Work, will be established, maintained, reviewed and assessed on an ongoing basis,
- f) safety equipment and apparel are properly used and worn by Workers and Other Persons, as required pursuant to the Regulation and the Base Safety Program, and
- g) a first aid program in compliance with the Regulation is established, implemented and maintained at all times on the Area of Responsibility.

135.04.04 The Prime Contractor will determine and control the manner in which the Base Safety Program is established, initiated, and maintained and the manner in which the instructions, directions, rules, policies and procedures contained therein are carried out.

135.04.05 Prime Contractor Obligations to Coordinate with Adjacent or Nearby Sites – If another party is the prime contractor in connection with another Adjacent or Nearby Worksite or Area of Responsibility, the Prime Contractor:

- a) will continue to undertake and perform the obligations of a Prime Contractor in the Area of Responsibility at all times in accordance with the terms of the Workers Compensation Act, the Regulation and this Section,
- b) will advise the other party in writing of the name of the Qualified Coordinator, and of any change in the Qualified Coordinator, designated to be responsible for the health and safety activities on or in connection with the Area of Responsibility, and any activities in the Adjacent or Nearby Worksite,

SECTION 135

CONSTRUCTION SITE SAFETY

c) will co-operate with the other party so as to accommodate any requests that may be issued by the other party to coordinate the health and safety activities on the Adjacent or Nearby Worksite, and

d) may request the cooperation and accommodation of prime contractors on Adjacent or Nearby Worksites to coordinate the health and safety activities in the Area of Responsibility.

135.05 Contractor

135.05.01 The Contractor, by entering into the Contract, agrees to, for the purposes of the Workers Compensation Act and the Regulation, the designation of the Prime Contractor and the Area(s) of Responsibility made by the Ministry pursuant to SS 135.03.01 to SS 135.03.04.

135.05.02 The Contractor will, prior to commencement of the Work, deliver to the Prime Contractor, in writing:

a) the name of each of the Qualified Person in connection with the Site, and

b) a copy of all Notices of Project.

135.05.03 The Contractor will, in connection with the Work and the Site:

a) observe, abide by and comply with the Workers Compensation Act and the Regulation,

b) deliver all required Notices of Project to the Workers' Compensation Board in accordance with the Workers Compensation Act and the Regulation,

c) prominently post and at all times maintain on the Site all Notices of Project in accordance with the Workers Compensation Act and the Regulation,

d) ensure that the person or persons to be appointed Qualified Person meet the qualifications of a "qualified person" as described in the Workers Compensation Act and the Regulation,

e) designate and at all times maintain not less than one Qualified Person to be responsible for health and safety activities of the Contractor in connection with the Work, including, without limiting the generality of the foregoing, administering the Base Safety Program, as it applies to the Contractor,

f) deliver written notice to the Prime Contractor of any change in the appointed Qualified Person referenced in SS 135.05.02a),

g) participate in the Joint Committee and ensure that the Contractor's Workers attend periodic safety meetings established by the Prime Contractor including the Prime Contractor's site safety orientation ,

h) establish and participate in Other Joint Committees and periodic crew safety meetings to inform the workers of any known or reasonably foreseeable risks on the Site and the

actions to be taken to eliminate or minimize those risks, and maintain minutes of those meetings,

i) establish and maintain at a location on the Site, or at a location off the Site that is satisfactory to the Prime Contractor, accurate records, including supporting documents, relating to the implementation, operation, and maintenance of the Base Safety Program, and to any other occupational health and safety matters relating to the Work

j) make the Base Safety Program and a copy of the Workers Compensation Act and the Regulation readily available at the Site,

k) provide and maintain the Site in a manner that ensures the health and safety of persons at or near the Site,

l) ensure that the Prime Contractor is given the information known to the Contractor that is necessary to identify and eliminate or control hazards to the health or safety of Workers and Other Persons at the Site,

m) ensure that the Prime Contractor, Workers, Employers and Other Persons are made aware of all known or reasonably foreseeable health and safety hazards to which they are likely to be exposed by the Work on the Site,

n) do everything that is reasonably practicable to establish and maintain a system or process that will ensure compliance with the Workers Compensation Act and the Regulation with respect to the Site,

o) immediately notify the Prime Contractor, Employers, Workers, Suppliers and Subcontractors of the Contractor, and Other Persons of any hazard created by virtue of overlapping or adjoining work activities of 2 (two) or more Employers and ensure that the hazards are addressed throughout the duration of such activities,

p) immediately notify the Prime Contractor and Ministry Representative of the occurrence of any accident that:

(i) resulted in serious injury to or the death of a worker,

(ii) involved a major structural failure or collapse of a building, bridge, tower, crane, hoist, temporary construction support system or excavation,

(iii) involved the major release of a hazardous substance, or

(iv) was an incident required by the Regulation to be reported.

q) comply with any directive related to occupational health and safety matters issued by the Prime Contractor, and

r) Provide to the Prime Contractor:

(i) the name of the person designated to supervise the Contractor's Workers,

(ii) the name of the Qualified Person(s),

- (iii) copies of safety meeting records and toolbox talks,
- (iv) copies of worksite inspections,
- (v) any and all notices, directives and inspection reports which have been delivered to the Workers' Compensation Board by the Contractor or which the Contractor has received from the Workers' Compensation Board,
- (vi) a list of known site hazards, and updates as hazards change,
- (vii) immediate notification of any incidents, including near misses,
- (viii) incident investigation reports,
- (ix) a written summary of the actions taken by the Contractor to coordinate, in conjunction with the Prime Contractor, the occupational health and safety activities of the Employers, the Workers, and the Other Persons within the Site,
- (x) statistical summaries, in the form provided in Appendix B of this Section, as necessary to respond to a request initiated by the Ministry Representative, and
- (xi) such other information as the Prime Contractor may request.

135.05.04 Payment Conditional Upon Documentation –

The delivery of any payments by the Ministry to the Contractor under the Contract is conditional on the prior submission to the Prime Contractor by the Contractor, of the documentation required under this Section.

135.06 Notice Process

135.06.01 Any Employer who becomes aware of an unsafe or harmful condition or act shall provide notice to the Prime Contractor in that Area of Responsibility.

135.06.02 If the Prime Contractor, in connection with the Area of Responsibility, determines, in its reasonable discretion, that:

- a) any Employer or its Workers has failed to comply with the Workers Compensation Act or the Regulation, or to act in accordance with the requirements of the Base Safety Program for coordinating health and safety activities,
- b) the failure creates or may create an unsafe or harmful condition in the Area of Responsibility that poses a danger of injury or death to Workers, the Prime Contractor, may issue a Notice of Unsafe or Harmful Condition or Act to the applicable Employer, stipulating in reasonable detail the basis for the issuance of the Notice of Unsafe or Harmful Condition or Act, and the Prime Contractor, will deliver a copy of the Notice of Unsafe or Harmful Condition or Act to the Ministry Representative.

135.06.03 The terms “Employer” and “Workers” referenced in SS 135.06, do not include the Prime

Contractor’s Subcontractors or Suppliers, or their respective employees, workers, servants, agents or invitees.

135.06.04 Upon receipt of the Notice of Unsafe or Harmful Condition or Act, the Ministry Representative will issue to the applicable Employer a Stop Work Order at the location in the Area of Responsibility that is specified in the Notice of Unsafe or Harmful Condition or Act.

135.06.05 The Ministry will be deemed to have relied on the terms of and reasons for the issuance of the Notice of Unsafe or Harmful Condition or Act, notwithstanding any subsequent investigation or inquiry of the matter by the Ministry which the Ministry may but will not be obligated to undertake.

135.06.06 If the Prime Contractor and the Employer referenced in SS 135.06.02 fail to agree on the reasons for the issuance of the Notice of Unsafe or Harmful Condition or Act, then within one day of the issuance of the Notice of Unsafe or Harmful Condition or Act, the directive of the Prime Contractor to rectify the failure to comply with the Regulation or to act in accordance with the Base Safety Program, as the case may be, will be immediately implemented.

135.06.07 When the failure to comply with the Workers Compensation Act or the Regulation in accordance with the Base Safety Program stipulated in the Notice of Unsafe or Harmful Condition or Act has been rectified, to the reasonable satisfaction of the Prime Contractor, by the Employer to whom it was given to, the Prime Contractor, will immediately:

- a) withdraw the Notice of Unsafe or Harmful Condition or Act by endorsing on a copy thereof confirmation that the failure to comply with the Workers Compensation Act or the Regulation in accordance with the Base Safety Program has been rectified.
- b) deliver the endorsed copy of the Notice of Unsafe or Harmful Condition or Act confirming the cancellation thereof to the applicable Employer and to the Ministry Representative.

135.06.08 The Ministry Representative will issue a Resume Work Order on receipt of the endorsed copy cancelling the Notice of Unsafe or Harmful Condition or Act.

135.06.09 If the Prime Contractor is delayed in performing the Work as a result of being required to issue the Notice of Unsafe or Harmful Condition or Act and the Work is stopped pursuant to an Stop Work Order under SS 135.06, then the Completion Date will be extended by the number of days equal to the delay, as determined in the sole discretion of the Ministry Representative, and the Prime Contractor will not be entitled to any compensation, in damages or otherwise, including without limiting the generality of the foregoing, any claim for lost profits or other consequential loss, including business loss, as a

SECTION 135

CONSTRUCTION SITE SAFETY

result of or in connection with the issuance and operation of any Notice of Unsafe or Harmful Condition or Act or the issuance and operation of any Stop Work Order pursuant to this Section.

135.06.10 Notwithstanding any other term of this Section or of the Contract, the Ministry may withhold any payment

due to the Contractor under the Contract if the Prime Contractor has issued, in connection with the Site, a Notice of Unsafe or Harmful Condition or Act in accordance with this Section, and the Ministry may continue to withhold such payment until such time as the Notice of Unsafe or Harmful Condition or Act has been cancelled and the Resume Work Order has been issued.

REVISED SECTION

APPENDIX "A"

PRIME CONTRACTOR'S NOTICE OF UNSAFE OR HARMFUL CONDITION OR ACT (the "Notice")

This Notice has been issued by the Prime Contractor to:

Name of Contractor: _____

Address: _____

The following unsafe or harmful condition or act was observed at the following location and time:

Description of unsafe or harmful condition or act: _____

Location: _____ Date: _____ Time: _____ AM/PM

The Contractor named in this Notice is required to correct the above referenced unsafe or harmful condition or act prior to performing any more work activity at the location identified above.

Prime Contractor: _____

Signature: _____ Date: _____ Time: _____ AM/PM

Receipt acknowledged by the Contractor:

Signature: _____ Date: _____ Time: _____ AM/PM

The Ministry Representative received a copy of this Notice on: Date: _____ Time: _____ AM/PM

On the basis of this Notice, the Ministry Representative will issue an "Stop Work Order" in connection with the unsafe or harmful condition or act as identified on this Notice.

The Prime Contractor will, if satisfied that the unsafe or harmful condition or act has been rectified cancel and withdraw this Notice.

Date of cancellation/withdrawal: _____ Time: _____ AM/PM

Prime Contractor - Signature: _____

The Ministry Representative will issue an "Resume Work Order" when in receipt from the Prime Contractor of this Notice endorsed to indicate that the unsafe or harmful condition or act has be rectified.

DISTRIBUTION: Original: Contractor Copy: Ministry Representative File Copy: Prime Contractor

APPENDIX "B"



BRITISH COLUMBIA

Ministry of
Transportation

**CONTRACTOR'S ACCIDENT
STATISTICS SUMMARY REPORT**

Project Number _____

Date (yyyy/mm/dd) _____

Description _____

Award Date (yyyy/mm/dd) _____

Completion Date (yyyy/mm/dd) _____

Name of Contractor _____

Month	Total Number of All Hours Worked by All Contractor's & Sub-contractor's Workers	Number of Reportable Accidents & Incidents	Number of Days Lost Due to Lost Time Accidents	Total Cost for Damage to Equipment or Material
Jan				
Feb				
Mar				
Apr				
May				
Jun				
Jul				
Aug				
Sep				
Oct				
Nov				
Dec				
Totals				

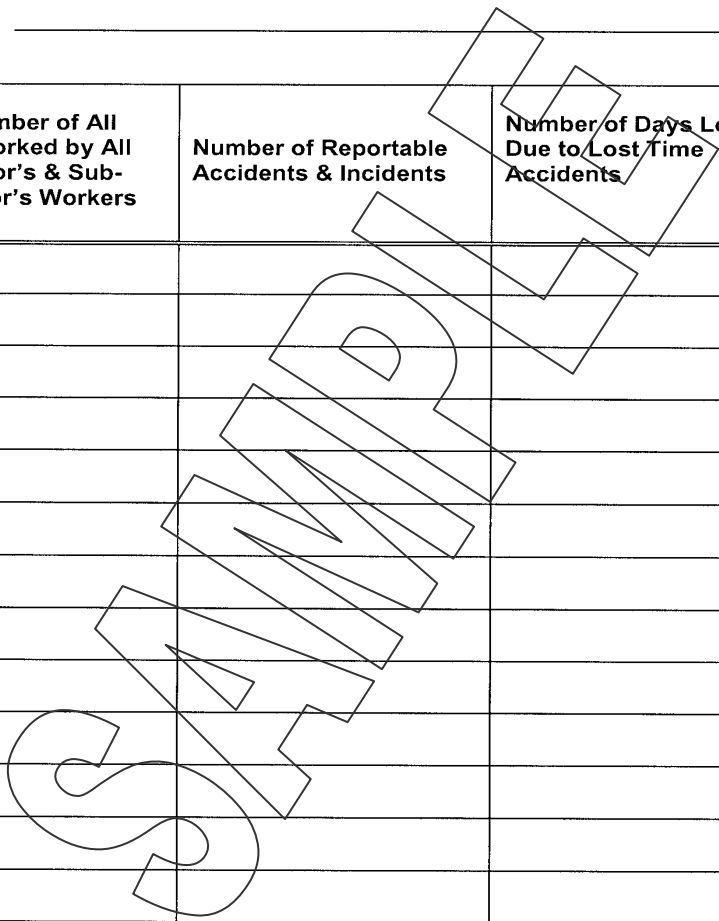

Contractor's designated authority - Signature _____

Print name of Contractor's designated authority _____

Attach additional copies of this form as necessary and submit to Ministry Representative upon contract completion.

CONSTRUCTION SITE SAFETY SIGN	SP135-01
-------------------------------	----------



NOTE:
CONTRACTOR PROVIDES COMPANY NAME AND PHONE NUMBER OF THE APPROPRIATE CONTACT PERSON.

SPECIFICATIONS

- SIGN SIZE (MINIMUM) 2440 mm x 610 mm (8'-0" x 2'-0")
(MINIMUM) 2440 mm x 305 mm (8'-0" x 1'-0")
- MATERIAL 10 mm PLYWOOD OR .081" SHEET ALUMINUM
- COLOUR BLACK MESSAGE ON WHITE REFLECTORIZED BACKGROUND
- TEXT SIZE 100 mm AND CENTERED HORIZONTALLY

NOT TO SCALE

ALL DIMENSIONS ARE IN MILLIMETRES UNLESS OTHERWISE NOTED

THIS PAGE IS LEFT INTENTIONALLY BLANK

REVISED SECTION

SECTION 145

GENERAL REQUIREMENTS FOR HIGHWAY, BRIDGE AND MARINE CONSTRUCTION

145.01 General Requirements – This Section covers the general Work requirements for highway, bridge, and marine construction.

The standards and materials specifications contained in the Standard Specifications for Highway Construction govern the specific requirements for the Work. Special Provisions provide additional specific requirements for the Work and supersede the Standard Specifications where there is conflict.

Specifications, standards, regulations and codes of other authorities named in full or by acknowledged abbreviations in the Glossary of Terms of the Standard Specifications or the Contract Document Package shall be adopted by reference.

Such reference in whole or in part by the necessary alphanumerical designation from the latest edition or revision is intended to fully detail the requirements of the Work.

145.02 Reference Information – Reference information for the Work identified in the Contract is made available for the Contractor to use for its own purpose. The Contractor shall be solely responsible for any interpretation placed thereon and for all impacts resulting from such interpretation.

145.03 Not Used

145.04 Scope of Work – The scope of Work is described in the Contract. No warranty is given or implied that any or all of this Work will be required or supplied.

145.05 Quantities and Dimensions – Quantities, dimensions, lines and elevations as shown on the plans and Drawings are designed neat lines. Approximate quantities entered in Schedule 7 – Approximate Quantities and Unit Prices are quantities approximated using the lines and dimensions shown in the Contract Document Package and other relevant factors, and may vary from quantities derived from the Drawings. Actual payment quantities will be measured, calculated, or otherwise determined in accordance with the Contract.

145.06 Unit Prices – Unit Prices in the Schedule of Approximate Quantities and Unit Prices shall be complete and contain all the elements of cost involved, provision of all things, superintendence and profits. The price shall stand independent of any other Unit Price Item on the Schedule of Approximate Quantities and Unit Prices.

145.07 Pre-construction Meeting – The Contractor shall prepare the required documentation in accordance with the Contract, then advise the Ministry Representative, who will determine the pre-construction meeting's location and time and notify the Contractor.

145.08 Mobilization – Mobilization consists of the necessary Work and operations including, but not limited to, the movement of personnel, equipment, supplies, and incidentals to the Site, the establishment of offices, camps, and other facilities necessary to undertake the Work and all other Work Items and operations which must be initiated and finished as part of completion of the Work.

145.08.01 Payment for Mobilization – Where the Contract includes a payment Item for mobilization, the Lump Sum Price for mobilization includes any or all of the related expenses incurred for mobilization, demobilization and any re-mobilization not covered under the Work Items which must be initiated and finished as part of the Work. The Lump Sum Price for mobilization will be paid in increments as the Work progresses.

If the Contract does not contain a payment Item for “Mobilization”, all costs associated with mobilization, demobilization and re-mobilization will be included in payment for Items having such costs.

Payment for mobilization, if applicable, will be made at the tendered Lump Sum Price as follows:

a) The Contractor will be paid any portion of the mobilization Lump Sum Price exceeding five percent (5%) of the Tender Price within sixty (60) days after the Actual Completion Date or on the final progress estimate (whichever occurs first).

b) That portion of the mobilization Lump Sum Price not exceeding five percent (5%) of the total Tender Price, will be paid to the Contractor according to the following breakdown:

- i) Seventy-five percent (75%) when the Contractor has submitted, in an acceptable form, to the Ministry Representative each of the following that is required under the Contract
- Construction Schedule,
 - Cash Flow Projection Schedule,
 - Traffic Management Plan,
 - Quality Control Plan,
 - Sediment and Drainage Management Plan,

and the value of the Work completed on bid Items other than mobilization exceeds two percent (2%) of the Tender Price.

ii) The remaining twenty-five percent (25%) of this portion of the mobilization Lump Sum Price will be paid prorated on a monthly basis for the percentage of Work completed as determined by the Ministry Representative when the Ministry Representative receives acceptable construction schedule updates, all

SECTION 145

quality control records or reports have been submitted by the Contractor as required by the Ministry, all equipment has been removed from the Site, and the Site has been cleaned up to the satisfaction of the Ministry Representative.

The payments from the Lump Sum Price, as set out above, will be full compensation for mobilization, demobilization and re-mobilization, regardless of the number of times the Contractor mobilizes.

145.09 Authority of the Ministry Representative – The Ministry Representative has the authority to accept or reject the Contractor's Work in accordance with the conditions set out in the Contract. Until the Work meets the requirements of the Contract and has been accepted by the Ministry Representative, the Ministry is not obligated to make payment for Work done by the Contractor. The Ministry Representative shall take all necessary measurements and calculations to determine the final quantities for final payment.

145.10 Power, Telegraph, Telephone Lines and Other Utilities – Moving of existing power, telegraph and telephone lines, poles and other utilities from their current to their final design locations, unless specified as being part of the Work, shall be performed by third parties at the Ministry's expense.

If the Contractor's operations require the temporary removal or relocation of lines or poles, such removal or relocation shall be entirely the responsibility of the Contractor and costs of any interim utility relocations shall be to the Contractor's account. Utility owner(s) must be contacted prior to doing any utility work.

The Contractor shall be responsible for any damage to poles, lines or utilities caused by the Contractor's construction operations, and shall repair and make good the same or bear the expense of making good and repairing the same.

The Contractor shall take the necessary precautions to protect existing utility services during the performance of the Work and shall be responsible for any losses or damages caused by the Contractor.

Locations of the utilities shown on the Drawings are approximate and may not be complete. The Contractor shall be responsible to ensure the locations of the utilities are complete and shall notify the Ministry Representative of any discrepancies between the Drawings and the Contractor's findings.

145.11 Permits – The Contractor shall give all requisite notices in connection with the Work to the proper authorities and shall procure at the Contractor's expense all permits, licences, etc., of every description necessary for the construction and completion of the Work.

The Contractor shall deliver or make available all original certificates to the Ministry Representative for all or any

GENERAL REQUIREMENTS FOR HIGHWAY, BRIDGE AND MARINE CONSTRUCTION

part of the Work for which such certificates may be required in connection with performing the Work.

145.12 Inspection of Work – All materials and each part or detail of the Work shall be subject to inspection by the Ministry Representative.

The Contractor shall be held strictly to the true intent of the Contract in regard to quality of materials, work practice and the diligent execution of the Contract.

The Ministry Representative shall be given access to all or any part of the Work, and to the preparation, fabrication or manufacture of the materials to be used. The Contractor shall furnish all information and assistance as is required to make a complete, true and detailed inspection.

The Ministry Representative may reject any part or parts of the Work which do not comply with the requirements of the Contract. The Ministry Representative's decision will be accepted as final.

Inspection may extend to all or any part of the Work and to the preparation, fabrication or manufacture of the materials to be used. The Ministry Representative may station others on the Site to report on the progress of the Work and the manner in which it is being performed.

The Ministry Representative will report to the Contractor on materials furnished or Work performed that fails to fulfil the requirements of the Contract.

Inspection or its lack shall not relieve the Contractor from any obligations to furnish acceptable materials or to provide completed construction Work that complies with the Contract.

The Contractor shall furnish for the approval of the Ministry Representative, at proper times, all shop and installation drawings as requested by the Contract or which the Ministry Representative may deem necessary.

In accepting Drawings submitted by the Contractor, the Ministry Representative will assume no responsibility as to the correctness of such Drawings and the Ministry Representative's examination is only to ensure general compliance with the Contract.

145.13 "Ministry Representative's Instruction" and "Contractor's Declaration"

145.13.01 "Ministry Representative's Instruction" – "Ministry Representative's Instruction" form (H0202) will be issued by the Ministry Representative to the Contractor in order to:

- a) describe a portion of the Work which may not be covered specifically in the Contract.
- b) confirm instructions which may affect the method of carrying out the Work or payment.
- c) confirm verbal agreements made with the Contractor's representative.

SECTION 145

d) respond to the Contractor's representation on "Contractor's Declaration" form (H0203).

145.13.02 "Contractor's Declaration" – The Contractor is to issue the "Contractor's Declaration" form (H0203) to the Ministry Representative in order to:

- a) make a declaration of acceptance or objection to contents of the "Ministry Representative's Instruction".
- b) formally present the Contractor's opinions, problems or requirements for clarification.

145.14 Protection and Restoration of the Work – The Contractor shall protect all Work and surrounding infrastructure from injury or damage until the issuance of the Completion Certificate.

If the Contractor fails to prevent any injury or damage to the Work, the Contractor shall rebuild, repair, and restore at its expense any portion of the Work so injured or damaged.

The Ministry may reimburse the Contractor for any injury or damage caused by an event not foreseen and not reasonably foreseeable by the Contractor and beyond the control and not resulting from any fault or negligence of the Contractor including but not restricted to acts of God, acts of a Public Enemy, acts of the Ministry, extraordinary action of the elements and unavoidable slides.

145.15 Materials Supplied by the Contractor – The Contractor shall provide all materials necessary for the orderly completion of the Work with the exception of the materials supplied by the Ministry as listed in the Special Provisions.

Further requirements for asphalt materials are contained in SS 502.

All materials supplied under the Contract shall:

- a) be new,
- b) conform to the requirements of the Contract, and
- c) be subject to inspection and approval by the Ministry prior to incorporation in the Work.

145.15.01 Inspection of Materials – Includes material certificates review, fabrication inspection, sampling and testing of materials.

The Contractor shall provide to the Ministry, material or mill certificates two weeks prior to shipping of the materials supplied by the Contractor. Such material or mill certificates shall include the material properties that demonstrate the material's compliance with the requirements of the Contract.

At the request of the Ministry Representative, the Contractor shall submit representative samples of materials at no charge to the Ministry.

The Contractor shall notify the Ministry Representative of the sources of materials supplied by the Contractor, and

GENERAL REQUIREMENTS FOR HIGHWAY, BRIDGE AND MARINE CONSTRUCTION

obtain the right for the Ministry to enter upon the premises of the material supplier or fabricator to carry out such inspection. Such notification shall be given sufficiently far in advance of materials delivery dates to enable the Ministry Representative to make inspection of the material at the source. Insufficient notice will be cause for the Ministry to reject the materials without compensation.

The Ministry will not be responsible for any delays to the Contractor's operations where the Contractor fails to give sufficiently advance notification to the Ministry Representative to enable the Ministry to carry out the inspection before the scheduled shipping dates.

The Contractor will be charged for all travel time, transportation, board and lodging costs incurred by the Ministry or its designate, required to inspect materials components if the source of material to be incorporated into the Work is outside the Province and.

The Ministry will offset any costs for inspecting the materials from any payments made to the Contractor.

145.15.02 Approval of Materials – The approval or acceptance of any materials shall not preclude later rejection of the same materials prior to acceptance of the complete work.

Any rejected material shall be removed from the Site and replaced at the Contractor's expense immediately after notification. All costs incurred for inspection, sampling and testing that established a material rejection shall be charged to the Contractor. In such cases, the Ministry may offset the cost of sampling and testing from any payments due the Contractor.

145.15.03 Alternative Materials – Brands, species and manufacturer's names specified are approved for use in the performance of the Work. No alternative materials will be considered unless approved in advance by the Ministry Representative in writing.

Savings as a result of using alternate materials will be evaluated using SS 125 Value Engineering.

145.15.06 Recognized Products List – The Ministry has reviewed a number of products for use in highway applications and publishes a "Recognized Products List", indicating which products are considered generally acceptable for particular purposes. Contractors are encouraged to review the list to aid in determining which products they will supply, but are cautioned that the products listed, although generally acceptable, may not meet Contract specifications.

The Categories "Proven," "Tentative" or "Approved" in the Recognized Products List are an indication of the product's record of use and purpose. Products in any category are "recognized" and may be used as long as the product meets Contract specific specifications.

SECTION 145

Unless so specified in the Contract, Materials provided are not required to be amongst those on the Recognized Products List.

The Recognized Products list is available on-line at: www.th.gov.bc.ca/publications/eng_publications/geotech/Recognized_Products_Book.pdf

145.16 Materials Supplied by the Ministry – Ministry supplied materials will be procured and paid by purchase order to the Purchasing Commission, who on instruction from the Ministry Representative notifying of Contractor requirement for the material, shall arrange for release of the material to the Contractor in accordance with the purchase order.

Separate purchase orders will be issued for each class of material.

Materials ordered for a specific Site shall not be transferred to any other Site without the written consent of the Ministry Representative.

Ministry supplied and owned materials will be used only for Ministry Work.

145.16.01 Delivery Points – Each purchase order will specify points of delivery. The Contractor shall be responsible for all costs that may arise such as unloading from truck or rail car, hauling to the Site, stockpiling, dunnage, and reloading.

The costs to transport all materials to the Site will be incurred by the Contractor at its own cost and will be considered incidental and no separate payment will be made for this portion of the Works.

Should the Contractor request delivery be made to an alternative point other than the nearest specified point of delivery or in any manner of delivery other than specified by the Purchasing Commission, the additional cost for this delivery shall be charged to the Contractor's account.

145.16.02 Delivery and Storage of Materials – When the Ministry Representative advises the Contractor of the name of the supplier(s), the Contractor shall be responsible at no cost to the Ministry for:

- a) determining requirements and ordering far enough in advance that work is not delayed.
- b) acceptance of all materials; careful unloading and handling; hauling and delivery from delivery point to job site; storage and security; prompt turn around of tank or shipping cars, trucks or delivery containers.
- c) prompt payment of all demurrage or rental charges on cars, freight, handling, delivery, storage or any other charges arising after the initial receipt of material at the delivery point.
- d) ensuring that proper accounting is kept of all materials received.

GENERAL REQUIREMENTS FOR HIGHWAY, BRIDGE AND MARINE CONSTRUCTION

The Contractor shall not unload or take delivery of any material without the presence of the Ministry Representative. The Contractor shall notify the Ministry Representative of materials delivery schedule and allow sufficient time for the Ministry Representative to check quantity and quality before any materials are delivered.

The Contractor shall report to the Ministry Representative any materials damage or discrepancies between the quantities received and the quantities shown on the bills of lading immediately upon Materials arrive at the delivery point. If damage or deficiencies are not so reported, it will be assumed that the materials arrived in good order.

The Contractor shall provide a secure storage acceptable to the Ministry Representative for all materials supplied by the Ministry. The Contractor shall, in advance of receipt of the shipment of the Materials notify the Ministry Representative of the storage facilities locations for their inspection and acceptance.

The materials shall be kept in the designated storage immediately upon receipt of the materials. The Contractor shall not remove any materials from the storage locations, except for incorporation in the Work, without authorization from the Ministry Representative.

The Contractor shall be solely responsible for recovery of any loss, damage, or improper use (including incorporating in the rejected Work) of any materials.

If asphalt materials are hauled directly from the delivery point for immediate application to the roadway, the material will be measured by mass or volumetrically by the Ministry Representative at the time of delivery. The Contractor shall ensure that an acceptable means of measurement is available.

145.16.03 Distribution of Materials – To control distribution of Ministry supplied materials and to facilitate accounting:

- a) the Contractor shall arrange for delivery of the materials only after applying for and receiving authority to do so on "Authority to Arrange for Delivery of Construction Materials" form (H0313). The requirements of the Contractor shall be indicated on Part "A" of the form. Approval from the Ministry Representative shall be indicated on Part "B" of the form. The Contractor may then arrange for delivery from the supplier. As delivery will be made only on receipt of the purchase order number and the serial number of the "Authority" form, the Contractor shall arrange with the Ministry Representative to immediately distribute appropriate copies of the "Authority" form.

Material suppliers will be required to notify both the Ministry Representative and the Contractor when materials are shipped, giving sufficient information to

SECTION 145

identify each and every shipment against an appropriate "Authority" form serial number and purchase order number.

- b) The use of the "Authority" form shall not in any way relieve the Contractor of any responsibility imposed under SS 145.16.02.
- c) If the Ministry Representative refuses to authorize the delivery of materials to the job, the Ministry Representative will send the refusal, with reasons in writing, to the Contractor.
- d) The Ministry may, at the completion of the Work, if materials are delivered in excess of job requirements through conditions beyond the control of the Contractor, take over the surplus material or grant the Contractor the option of purchasing the material on Site. The transaction will be completed only after the Contractor obtains for the Ministry Representative, a supplier's credit note for the total cost to the Ministry of the excess material purchased f.o.b. at the delivery point.

Upon completion of the Work, the Contractor will deliver all unused materials, which have been purchased by the Ministry, to a location as specified by the Ministry Representative and shall dispose of all empty materials packaging that are not required for their original purpose at the disposal site. No payment will be made for this portion of the Work.

145.17 Operation of Pavement Brooms on Highway – No mechanical pavement broom shall be operated on any highway without a rotating amber flashing light in operation. The light shall be mounted on self-propelled brooms and upon the towing vehicle of trailer type brooms.

Traffic Control is to be in accordance with the Traffic Control Manual for Work on Roadways. In addition, on extremely winding narrow roads an additional shadow vehicle shall be used ahead of the broom with a C-37 on the front of the vehicle and a flashing arrow in bar mode.

145.18 Supply and Maintain Facilities

145.18.01 Working Office – When required under Special Provisions, the Contractor shall provide a suitable working office with lock-up for the sole use of the Ministry. The office shall meet the requirements of Appendix A and be weatherproof, reasonably soundproof, and have ample window area and ventilation. Location of the office shall be determined by the Ministry Representative.

The Contractor shall regularly collect refuse and keep the office clean and properly maintained with heat and light.

The office and contents shall be for the use of the Ministry for the duration of the Work and may if necessary be used concurrently with the other inspection agencies.

GENERAL REQUIREMENTS FOR HIGHWAY, BRIDGE AND MARINE CONSTRUCTION

The Contractor shall supply a private telephone line for the sole use of the Ministry Representative. Ministry's long distance calls will be paid for by the Ministry.

Payment for the Ministry's Site Office (when requested) will be made at the Lump Sum price in the Contract.

Payment will include the provision of the office, furnishings, maintenance through out the Term, and removal in its entirety.

Payment of 50% of the Lump Sum will be made when the office is ready for occupancy and the remaining 50% after the office has been removed and the Site cleaned up to the satisfaction of the Ministry Representative.

145.18.02 Testing Facility – When required by the Special Provisions, the Contractor shall provide the Ministry with a material testing facility with a minimum of 12 m² floor space either in the form of a small trailer or the portion of a large trailer. The testing facility shall include power, light, heat, ventilation, plus basic furniture to permit testing and preparation of test records. The facility shall be stable, reasonably quiet and lockable.

Payment for the Ministry's Material Testing facility (when required) will be made at the Lump Sum price in the Contract

Payment will include the provision of the facility, furnishings, maintenance through out the Term, and removal in its entirety.

Payment of 50% of the Lump Sum will be made when the facility is ready for occupancy and the remaining 50% after it has been removed and the Site cleaned up to the satisfaction of the Ministry Representative.

145.18.03 Service for Ministry Facilities – Where the Ministry provides its own facilities on Site, the Contractor shall, for the duration of the Contract, provide light and heat and any other services requested by the Ministry Representative for same, and the Contractor will be compensated on a Force Account Basis.

145.18.04 Weigh Scale – The Contractor shall provide a truck weigh scale wherever measurement of materials by mass is required.

The weigh scale shall be an approved electronic weigh scale or platform type with remote balancing beam. The scale shall be of sufficient size and capacity to weigh, at a single pass, the largest, rigid-framed haulage vehicle to be used on the job and in any case shall be of not less than 13 t (tonne) capacity. The scale shall be capable of weighing all loads to within 20 kg of the true mass.

At the start of the Work, and as frequently as the Ministry Representative may deem necessary in order to ensure the accuracy, the scale shall be calibrated and checked at the Contractor's expense by an Inspector of Weights and Measures.

SECTION 145

The remote balancing beam shall be enclosed in a sound, watertight, dust-free scale house, properly ventilated and insulated. Adequate heating must be provided when the shade temperature is below 16°C.

The scale house shall be provided with full length windows facing the scale platform, and windows shall also be provided at either end, so that both the Contractor's scaleperson and the Ministry Representative's scale checker can at all times see vehicles to be weighed, not only on the scale but also approaching and leaving.

The front window shall be sufficiently large and low that the whole scale platform is readily visible to the Ministry Representative's checker. Immediately behind the balancing beam, a bench or table of sufficient length shall be provided to permit both scaleperson and checker to sit abreast in a position in which they can both write on the table and view the electronic scale or weigh beam and scale platform. Drawing SP145-01 shows these requirements.

The Contractor shall supply and maintain, at no additional expense to the Ministry, portable washroom facilities at the weigh scale site.

Payment for the weigh scale and ancillary facilities shall be incidental to the Unit Prices of the materials being weighed.

145.19 Weighing Materials – The Contractor shall supply, at no additional expense to the Ministry, a qualified scaleperson to carry out the necessary weighing which will be monitored by the Ministry Representative's scaleperson.

A weighing certificate prepared in triplicate, certified by the Ministry Representative's scaleperson, will be issued for each load. The required certificate will be supplied by the Ministry. The Contractor will be paid only for such material as has been acknowledged by the Ministry Representative's checker as having been received at the point of delivery designated by the Ministry Representative.

The delivery receipts will bear the signature, initials or other approved marking of the issuing Ministry Representative's scaleperson and receiving checker.

If the Contractor has an automated scale and the following conditions are being met, the Contractor shall not be required to supply a scaleperson:

- a) All weighed material is being delivered to a single Ministry job site. If the Contractor is delivering to two or more Ministry job sites at the same time, the Contractor shall supply a scaleperson as detailed in the first paragraph.
- b) Truck operators do not require instruction.
- c) There are no overloads, tarp covering, spillage difficulties, or any safety problems.

GENERAL REQUIREMENTS FOR HIGHWAY, BRIDGE AND MARINE CONSTRUCTION

- d) The scale platform is maintained by the Contractor to be clean and free from loose material at all times.

Should any of the above four conditions not be met, the Contractor shall provide a qualified scaleperson upon the instruction of the Ministry Representative.

In the event the Ministry Representative determines a scaleperson is not required, all weighed vehicles must be tared by both the Ministry Representative and the Contractor together once a day. In the event that any of the above conditions are not being met, at any time during the Term, in the opinion of the Ministry Representative, then the Contractor shall supply a scaleperson as detailed in the first paragraph.

145.20 Not Used

145.21 Layout of Work and Calculation of Quantities-

A number of key reference points of control line (primary) for the establishment of the design control line will be provided by the Ministry to enable the Contractor to lay out the Work. The Contractor shall assume full responsibility for the alignment, dimensions and elevations of each and every part of the work and their mutual agreement.

145.21.01 Ministry Responsibilities – The Ministry will survey the original ground line, and any subsequent material horizons, for determination of appropriate pay item quantities.

Where the Ministry has a pre-existing survey of the Site, the Ministry may use that survey as the original ground. If the Ministry elects to use such a survey, the Ministry Representative will notify the Contractor of such intent and give the Contractor an opportunity to view the cross-sections, contours, or Digital Terrain Model. Any areas of the survey or model that do not adequately reflect the Site at the start of construction will be identified by the Contractor or the Ministry and will be resurveyed by the Ministry prior to the Contractor starting work in any affected area of the Site.

Unless otherwise specified in the Contract, calculation of quantities will be on a neat line basis, as calculated from the design lines shown on the Drawings, adjusted to incorporate design changes and field-fits authorized by the Ministry Representative. Any material placed or excavated beyond the design lines is considered Unauthorized Work.

For items such as Type D excavation where the upper boundary of a cut cannot be determined until the completion of stripping, the design line will be revised to reflect the actual bottom of stripping line as determined by the Ministry's survey.

Quantities calculated from digital terrain models will be done using average-end-areas based on cross-sections extracted from the model or, at the Ministry

SECTION 145

Representative's option, by using prismatic volumes between surfaces in the model.

Where agreeable with the Contractor, alternate methods of determining payment quantities may be employed.

The Contractor may be required to adjust its construction activities from time to time to allow the Ministry's measurement work to proceed unencumbered. The Contractor shall not proceed with the next stage of any construction until the Ministry has completed measurements of the previous work.

Quality Assurance and checking of layout may be performed by the Ministry Representative.

145.21.02 Contractor's Responsibilities – The Contractor shall perform all layout of the work and all other survey work required to execute the Contract and construct the works in accordance with the Contract.

The Contractor shall be responsible for establishing all secondary control points and/or lines, all slope stakes, the establishment of line and grades for subgrade and the various granular aggregate layers, layout by line and grade of all structures, culverts, and underground utilities, and shall perform all other layout and measurement necessary for the proper execution of the Contract.

The staking of all works shall be of a sufficient accuracy and frequency for the Ministry to carry out its quantity measurements and quality assurance program.

On request of the Ministry Representative, the Contractor shall submit documentation to verify the accuracy of the layout work.

The Contractor shall be satisfied, before commencing any Work, as to the meaning, intent and accuracy of any control points, control lines and benchmarks established by the Ministry.

Should the Contractor discover or suspect any errors in any control points, control lines, benchmarks, and data provided by the Ministry, the Contractor shall at once discontinue the affected work until such errors are investigated by the Ministry Representative and, if necessary, rectified.

No separate payment will be made for layout work and the cost thereof will be considered incidental to the various items of work to be performed in the Contract.

The Work shall be so laid out and constructed that the location of substructure elements and anchor bolt groups shall not differ from the true positions by more than the following amounts:

- a) Substructure elements – 12 mm
- b) Anchor bolt groups – 6 mm.
- c) The elevation of bridge seats shall not differ from true elevations by more than 3 mm.

GENERAL REQUIREMENTS FOR HIGHWAY, BRIDGE AND MARINE CONSTRUCTION

Any deviation beyond the above mentioned tolerances shall be satisfactorily corrected by the Contractor at the Contractor's expense.

145.22 Access to Site – The Contractor shall provide access to the Site as may be necessary. No separate payment will be made for the provision of any access roads or incidental works in connection therewith.

The Contractor shall make arrangements with the property owners adjacent to and around the terminal site for the use of access and for the use of any storage areas the Contractor may require. The Contractor shall acquire such access and storage rights at the Contractor's expense.

In the event of roads being temporarily closed to the travelling public, the Contractor shall, at the Contractor's expense, provide, erect and maintain all requisite barriers, fences or other proper protection and must provide, keep and maintain such patrollers, lights and danger signals as may be necessary, or as may be required by the Ministry Representative to ensure safety to the public and to the workers.

The Contractor, during the Contractor's operations, must also provide and maintain reasonable road access and egress to property fronting along or in the vicinity of the work under contract, unless other means of road access exists. The Ministry Representative will be the sole judge as to what may be deemed reasonable road access.

145.23 Accommodation of Traffic – The Contractor shall cause as little inconvenience as possible to the travelling public during the Contractor's operations and shall erect and maintain proper and adequate barricades, traffic signs, lights and other traffic control devices as may be considered necessary, in the opinion of the Ministry Representative, for the safety of both workers and public traffic.

All barricades, traffic signs, lights and other control devices shall be provided at the Contractor's expense, and shall be erected in accordance with, and otherwise conform to the standards as set out in the Ministry's "Traffic Control Manual for Work on Roadways", Special Provisions and Standard Specifications.

145.23.01 Maintenance of Traffic – The Contractor shall comply with the requirements of the Transportation Act and amendments thereto and such other Acts, By-Laws or Regulations as are in force for the governing and regulating of traffic or use of any road upon or over which it is necessary to do work or transport materials. The Contractor must arrange to keep roads open to traffic at all times and must cause as little inconvenience as possible to the travelling public.

145.23.02 Road Closure Notification – Road closures shall not be permitted until the Contractor requests and receives written permission from the appropriate authority

SECTION 145

in the Ministry. This request shall be submitted in writing not less than seven days in advance of the closure.

Upon receiving written permission for closure, the Contractor shall notify the local police, fire, ambulance, municipality, school board, and public transit at least 72 hours in advance of the closure.

The Contractor shall notify the public by local radio and newspaper at least 24 hours in advance of the closure.

All costs related to the above shall be for the Contractor's account.

145.24 Alterations to Drawings and Plans – It shall be understood that the Drawings and Plans represent the nature and general layout of the work to be executed and not necessarily the works exactly as they will be carried out. The Ministry Representative will, without invalidating the Contract, be at liberty to make any reasonable alteration or to furnish any additional or amended Drawings which do not radically change the type of construction.

Payment for any such altered Work will be at the rates set forth in the Schedule 7 Approximate Quantities and Unit Prices.

145.24.01 Adherence to Drawings – The various parts of the Work shall be built in strict accordance with the furnished Drawings and with any supplementary Drawings which may be furnished during the progress of the Work as occasion requires.

Special Provisions, special specifications, Standard Specifications and the Drawings/Plans are to be considered as explanatory of each other, but should anything appear in one that is not described in the other, or should any discrepancy appear, no advantage shall be taken of such omission or discrepancy and the decision of the Ministry Representative as to the true intent and meaning of the Special Provisions, special specifications, Standard Specifications and the Drawings in such instances shall be final and binding, it being clearly understood that the Contractor is to execute all the works requisite for the perfect completion of each and all of the several parts of the Work according to the true intent and meaning of the Contract..

On all Drawings, in case of any discrepancy between the figured dimensions and the scaled dimensions, the figured dimensions shall govern.

145.25 Use of Explosives – In using explosives the Contractor shall exercise the utmost care so as not to endanger life or property and, whenever directed, the number and size of the charges shall be reduced. Before doing any blasting the Contractor shall ascertain if there are in the neighbourhood any railway, power or other lines, water or other pipes, etc., which are likely to be in danger of being damaged. The Contractor shall give to the owner

GENERAL REQUIREMENTS FOR HIGHWAY, BRIDGE AND MARINE CONSTRUCTION

of such lines, pipes or other works timely notice of the intention to blast.

Whenever possible electric batteries shall be employed for simultaneous blasting.

The storage of explosives shall be in accordance with the regulations of the Canada Explosives Act and with any requirements of the representative of the Explosives Regulatory Division within the Mineral Technology Branch of the Minerals and Metals Sector of the Federal Department of the Natural Resources Canada.

145.26 Work in Pits or Quarries – The Contractor shall be responsible for compliance with appropriate environmental, forestry, agricultural and other applicable regulatory agencies for all work related to development, operation and reclamation of pit or quarry.

Prior to any work at the pit or quarry, the Contractor shall prepare and submit to the Ministry Representative for acceptance, plans of pit development, operation and reclamation. The plans shall demonstrate compliance with the appropriate local and provincial regulatory agencies.

145.26.01 Ministry Pit or Quarry – When operating in a Ministry pit or quarry where the Ministry retains the role of Pit Manager, the Contractor shall comply with all provisions of the Mines Act, the Health, Safety and Reclamation Code for Mines in British Columbia, and/or the WCB Occupational Health & Safety Regulation, as applicable to the work undertaken.

The Contractor shall appoint a properly qualified supervisor or shift boss in any Ministry pit or quarry where work is undertaken, in compliance with Section 26 of the Mines Act, and ensure that the supervisor or shift boss is certified in accordance with Section 1.13 of the Health, Safety and Reclamation Code for Mines in British Columbia.

When the Contractor is operating in a Ministry pit or quarry, the Contractor shall utilize the pit or quarry in accordance with the Ministry Pit Development Plan or obtain written approval from the Ministry Representative prior to deviating from the plan. Upon completion of the work, the Contractor shall reclaim the pit in accordance with the Reclamation Code of Mines.

Ministry pits or quarries may be used without charge, provided they are utilized, worked and maintained in accordance with the Standard Specifications and the Ministry's development plans. Prior to the removal of any aggregate material, the Contractor shall obtain written approval from the local District Manager Transportation. No warranty is given or implied that the source of aggregate material from the Ministry pits or quarries will meet requirements or requisite quantities.

The Contractor shall contact the Road and Bridge Maintenance Contractor a minimum of two (2) weeks

SECTION 145

before the date the Contractor anticipates the use of any Ministry pits or quarries.

The Contractor and the Road and Bridge Maintenance Contractor shall co-ordinate their activities and schedule usage of the pit among themselves and any other affected parties.

The Contractor, by entering an available source, will be deemed to have accepted all obligations, risks and costs for the production of aggregate meeting the contract requirements, just as if the pit or quarry was private. No warranty is given that the source will meet the quality and quantity requirements. The Contractor, without any additional compensation, shall provide whatever selection, screening, crushing, mixing, blending or other processing of any kind may be required to produce aggregate meeting all requirements for its intended use, including but not limited to:

- specified aggregate gradation,
- fracture count,
- aggregate quality requirements such as but not limited to those set out in SS 202.04 and Table 501-D of SS 501 as applicable, and
- the specified properties of any products into which the aggregate is to be incorporated.

The Contractor shall comply with the Ministry pit development plan and the Ministry Representative's directions regarding the location of material extraction within the pit by the Contractor.

The Contractor's use of Ministry pits is limited to the extraction of previously unexcavated material from the bank, for the supply of materials for use on this Contract.

The Ministry's Road and Bridge Maintenance Contractor has certain rights and obligations with respect to some Ministry pits, and the Contractor shall coordinate its activities with those of that contractor, where applicable, and with any other users, to the satisfaction of the Ministry Representative and the Ministry's District Manager, Transportation.

No separate payment will be made for clearing, grubbing, disposal or relocation of stockpiles, debris or contaminated materials, or for any other costs of site preparation, pit development, or access, or for any delay or other cost arising from the use of Ministry pits by others, and all costs thereof shall be covered in the prices for the Items under which payment is provided for the applicable materials.

145.26.02 Private Pit or Quarry – Prior to supply of any material to the Site, the Contractor shall obtain and provide to the Ministry Representative written approval from the titled land owner, for the right to occupy and operate private pit or quarry, including appropriate permits.

GENERAL REQUIREMENTS FOR HIGHWAY, BRIDGE AND MARINE CONSTRUCTION

Availability and use of the listed reserves or any other private aggregate source must be arranged by the Contractor. Prior to the removal of any aggregate material from an aggregate source, the Contractor shall provide a written notice from the owner authorizing the Contractor to remove aggregate material for use in the work.

145.27 Highway Right-of-Way – The Contractor shall confine its operations to the highway right-of-way and Licences to Construct as shown on the Drawings. Any land, property or water lot outside these boundaries required for construction yards, access roads, disposal or storage areas, or other operations of the Contractor, shall be acquired by the Contractor at no additional expense to the Ministry. The Contractor shall make arrangements for the use and compensation of such land with the titled land owner.

Work within the Site shall be confined to that necessary to construct the Project to the lines and grades specified. Excavation outside the design lines and grades to extract aggregates or for other purposes is prohibited unless authorized in advance by the Ministry Representative.

145.27.01 Not Used

145.27.02 Disposal Site Outside the Right-of-Way – Waste, or other materials specified or designated by the Ministry's Representative to be disposed of, such as, but not limited to clearing and grubbing materials, fences, old culverts, old concrete and asphalt, etc., shall be removed from the Site to a disposal site provided by the Contractor. All disposal sites shall be the responsibility of the Contractor.

The Contractor shall ensure that the disposal site complies with all Federal, Provincial, Municipal and Regional by-laws and regulations prior to disposing of the material. Any fees incurred shall be paid by the Contractor. The Contractor must provide documented proof to the Ministry Representative for the use of the selected disposal site.

In addition, the Contractor shall ensure that the disposal site complies with all municipal and regional government by-laws and regulations and, when relying upon any exemption permitted under section 2(d) of the *Agricultural Land Reserve Permit Regulation*, shall provide a written confirmation from the Regional District of their agreement that no permit is required.

145.27.03 Access Roads to Private and Public Lands – The Contractor shall not block or impede the use of any private access roads or driveways during the Work of this Contract without the consent of the Ministry Representative.

The Contractor shall schedule any anticipated closure of an access with the property owner to minimize impact on the owner.

145.28 Protection of Land Subdivision Monuments, Roads and Property

SECTION 145

145.28.01 Protection of Subdivision Monuments – The Contractor shall protect, preserve, and keep uncovered all land subdivision monuments or property marks during its construction activities which may cause disturbance to them. At points where construction activities will cover or destroy any land subdivision monuments or property marks, the Contractor shall be responsible for their protection from disturbance until their positions have been referenced. The Contractor shall not remove them until so directed by the Ministry Representative.

145.28.02 Protection of Survey Monuments – The Contractor shall be responsible for the preservation during construction of all geodetic benchmarks, survey monuments and property markers on the right-of-way. The Contractor shall use, at no additional expense to the Ministry, a British Columbia Land Surveyor to replace any survey monuments destroyed or damaged as a result of the Contractor's negligence. At locations where construction work will cover or destroy such markers, the Contractor shall not move or remove them until written direction is received from the Ministry Representative.

145.28.03 Protection of Roads – The Contractor shall ensure all equipment working on or hauling material on to and from the Site does not damage or deposit material onto any part of an existing roadway. Materials spilled onto the public roadways or driveways opened to public traffic shall be cleaned up immediately. The Contractor has the full responsibility to repair any damage to existing highways, local roads and driveways caused by its construction equipment and/or operations.

145.28.04 Protection of Railway Property – The Contractor shall be wholly responsible for any damage to railway trackage or property on the railway company's right-of-way resulting from highway construction operations. It shall be the Contractor's responsibility that all workers and persons employed by the Contractor or the Contractor's agents, or under the Contractor's control, shall use due care that no person or property is injured, and that no rights are infringed in performing the work. The Contractor shall compensate injured parties.

All costs for employment of traffic control persons or other personnel required for the protection of the railway trackage or property shall be the responsibility of the Contractor. Where it is found necessary to re-route any telegraph or telephone lines during the course of operations, or where it is found necessary to make repairs to such installations as a result of contract operations, such re-routing or repair work shall be the responsibility of the Contractor, and shall be for the Contractor's account.

Any costs borne directly by or billed directly to the Ministry which relate to the above responsibilities will be charged to the Contractor with a surcharge of 20%.

The Contractor shall restore and clean all slopes between the highway and the railway track together with any

GENERAL REQUIREMENTS FOR HIGHWAY, BRIDGE AND MARINE CONSTRUCTION

fences, ditches and drains disturbed by the work to the satisfaction of the Ministry Representative.

The Contractor shall give advance notice to the railway company prior to carrying out any work on the railway right-of-way and shall not proceed without specific coordination with the railway company and its schedule, and notice to the Ministry Representative.

145.28.05 Construction Stakes, Monuments, Bench Marks and Tide Gauge – The Contractor shall set, as the Ministry Representative may direct and as is necessary for the proper layout of the Work, monuments and bench marks of concrete or other material sufficiently permanent and rigid to remain intact during the duration of the Work. The Contractor shall particularly avoid destroying or disturbing such monuments or construction stakes and, should such destruction be unavoidable, shall notify the Ministry Representative in advance so that the points may be properly referenced and re-established.

145.28.06 Protection and Restoration of Property and Environment – The Contractor shall not enter upon private property for any purpose without first obtaining permission of the owner of that property and shall be responsible for the preservation of public property along and adjacent to the Work, and shall use every reasonable precaution necessary to prevent damage or injury thereto.

The Contractor shall be liable for all damages caused by fire started by the Contractor and shall, under no circumstances start fires without first securing the required permits and approval of authorities having jurisdiction even though it may be ordered or required to do such burning.

145.29 Haul Routes and Overloads – The Contractor shall be responsible for ascertaining that the Contractor's haul routes are acceptable to the authority having jurisdiction for highway loading.

Overweight or oversize vehicles are not permitted to use existing highway as a haul road for the hauling of construction materials, notwithstanding Section 7.01 of the Commercial Transport Regulation 1980 Consolidation, as amended from time to time.

Off-highway equipment may be permitted to cross the existing highway only at specific locations as approved by the Ministry Representative.

Once the crushed granular base, surfacing or pavement work has commenced on any portion of the new, reconstructed or relocated highway, no overloads will be permitted on that portion unless written approval is given by the Ministry Representative.

145.30 Health and Safety

145.30.01 Occupational Health and Safety Program – The Contractor shall provide an Occupational Health and Safety Program at the time of the pre-construction meeting

SECTION 145

and have it in place prior to the commencement of any Work. The Contractor shall provide evidence that an Occupational Health and Safety Program is in place at the pre-construction meeting.

Any delays in commencement of the Work related to acceptance of the Contract and site specifics of the Contractor's Occupational Health and Safety Program or interruptions of the Work related to the implementation of the Occupational Health and Safety Program are not Reimbursable Delays unless otherwise agreed to in writing by the Ministry Representative.

145.30.02 Worksite Hazards – The Contractor has the responsibility to identify worksite hazards and shall develop operational occupational safety policies and procedures and plans which are specific to the Work to ensure the safety of all persons at the Site and the travelling public passing through the Site.

When requested by the Ministry Representative, the Contractor shall provide copies of any safety policies, procedures or plans verifying steps have been taken to make all concerned fully aware of all hazards or unsafe conditions in accordance to SS 135 – Construction Site Safety.

The Contractor shall provide for the safety, protection and convenience of the general public and residents along the highway.

The Contractor shall erect and maintain signs, fences and barricades at the ends of the bridges before they are opened to traffic and at other dangerous areas of the Project, as necessary to prevent access of vehicles and pedestrians to the unfinished bridge and other dangerous areas.

145.30.03 Equipment – All trucks and other equipment used by the Contractor whether owned or rented for use on the Project shall meet manufacture's specifications for its purpose.

All trucks and other equipment rented by the Contractor for use on the Project shall when practicable be qualified local trucks obtained from local residents.

For the purposes of this Section, qualified local truck means a truck that meets all the following:

- a) a truck that has Motor Carrier approval.
- b) where the Contractor has a collective agreement with its employees the truck operator is a member of, or has the permission of the appropriate bargaining unit.
- c) the truck fulfils, in the opinion of the Ministry Representative, the specialized needs of the Contractor.
- d) a truck registered on the Ministry's Hired Equipment list for the geographic area encompassing the Site to in adjacent areas.

GENERAL REQUIREMENTS FOR HIGHWAY, BRIDGE AND MARINE CONSTRUCTION

Hire of trucks and other equipment paid on a production rate basis constitutes a Subcontract.

145.30.04 Audible Back Up Warning Device – All haul vehicles shall be equipped with an automatic audible warning device which will activate whenever the vehicle is backing up. The warning device shall be clearly audible above the ambient noise level at a minimum distance of 6 m from the back of the vehicle

145.31 Unacceptable Work – The Contractor shall correct promptly any Unacceptable Work to the satisfaction of the Ministry Representative.

145.32 Temporary Excavation – Where temporary excavations are undertaken in the course of the Work, the Contractor shall be responsible for maintaining the stability of adjacent ground and all structures and other works thereon, and for the cost of any temporary works which it provides for this purpose for which payment is not expressly provided in the Contract

145.33 General Sign Requirements

145.33.01 Contractor Identification Signs – The Contractor may supply and install contractor identification signs for the Term. The Contractor shall maintain and remove such signs and all costs of supply, installation, maintenance and removal shall be the responsibility of the Contractor.

The contractor identification sign shall display only the Contractor's company name and beneath it the word "Information" followed by a telephone number which directly connects any caller to the Contractor's personnel who are familiar with, and are currently active on the Project.

The sign will not be reflectorized, and the background colour will not be either red, yellow or orange. The sign dimensions will not exceed 2,400 mm horizontal and 1,200 mm vertical, and the text size (height) will not be less than 150 mm.

The contractor identification sign will be erected only in conjunction with the C-35 project identification sign, and will not be in advance of or at the same location as the C-35 sign. Where there is no C-35 sign, no contractor identification sign will be permitted.

No contractor identification sign may be installed without prior approval of both the sign and the intended installation and location by the Ministry Representative who, in determining whether or not to grant such approval, will not necessarily be limited to the requirements set out above.

145.33.02 Prime Contractor Sign – When designated as the Prime Contractor, the Contractor shall provide "Prime Contractor" sign as specified in SS 135 Construction Site Safety.

145.33.03 Traffic Control Signs – The Contractor is required to use the appropriate encapsulating or prismatic

SECTION 145

lens sheeting on the following traffic control signs in the work zone:

- a) encapsulating lens sheeting (identified by the “honeycomb” pattern) on:
 - C-2.....Survey Crew/Speed Limit;
 - C-4.....Crew Working;
 - C-15 & C-16...Temporary Slow & Hazard Marker;
 - C-36.....Survey Crew; and
- b) prismatic lens sheeting (identified by the diamond shaped pattern) on:

GENERAL REQUIREMENTS FOR HIGHWAY, BRIDGE AND MARINE CONSTRUCTION

- C-27 Stop/Slow Paddle.

All the above traffic control signs shall meet current Ministry specifications. The Ministry *Specifications for Standard Highway Sign Materials, Fabrication and Supply* are located on our Ministry web page at:

http://www.th.gov.bc.ca/publications/eng_publications/signs/Sign_Fabrication_Specs.pdf

All costs to provide, replace and use the required control signs in the work zone will be included in related work items and no additional compensation will be made.

APPENDIX AMinistry Office Requirements

REQUIREMENTS FOR OFFICE TYPES			
Office Type	A	B	C
Lockable desk/chair	1	2	3
Typist desk/chair	-	-	1
Drafting table 1.2 m x 2.4 m /stool	1	1	1
Reference table 1.2 m ²	-	1	3
Conference table 1.2 m x 2.4 m	-	-	1
Additional chairs	2	2	9
Plan case or drawing storage unit	1	1	2
Filing cabinet (# drawers)	1 – 2 drawers	1 – 4 drawers	3 – 4 drawers
Shelving bookcase m ²	2	5	20
Fire Extinguisher for Class A, B and C fires	1 – 5 kg	1 – 5 kg	2 – 5 kg
Supply Activated Telephones and Lines	One (1)	One (1)	Three (3) on two (2) lines with external bell and switch
Toilet	On site	On site	In washroom, hot and cold running potable water and wash basin
First Aid Kit	On site	#1 Unit Kit	#1 Unit Kit
Floor Areas – m²			
a) Entrance	-	-	5
b) Ministry Representative's office	12	12	12
c) Additional Staff office	-	8	20
d) Wash room	-	-	As required
e) Store room	-	-	5

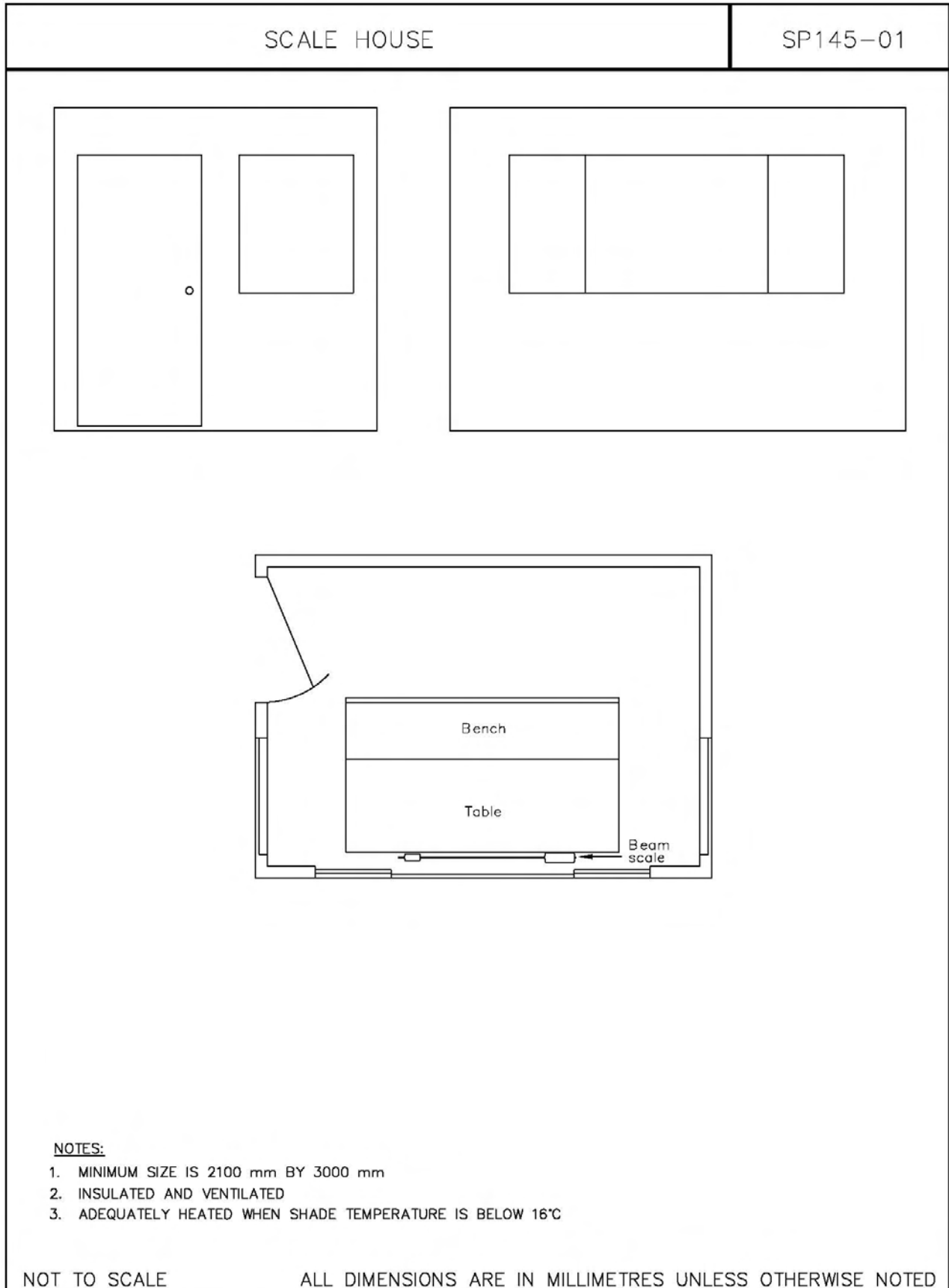

SECTION 165

PROTECTION OF THE ENVIRONMENT

165.01 General - This Section covers the general and specific provisions for the protection of the environment under the direction of the Ministry Representative, in cooperation with any Federal and/or Provincial Environment officers or an Environmental Monitor, as designated in the Special Provisions.

165.01.01 Intent of Specifications - These Specifications give the Ministry or its Agent the right to exercise control over environmental aspects of the work. The Contractor shall adhere to specific instructions if the work may result in an adverse impact on the environment.

The Ministry will determine the significance of environmental impacts in consultation with Environmental Agencies. The Ministry reserves the right of approval over the general methods employed by the Contractor in the performance of the work, but only insofar as they may affect relations with Environmental Agencies and the protection of aquatic and terrestrial resources, the health and safety of public, and protection of socio-community resources and features.

These specifications are for the protection of the environment, and shall be given such interpretation as will secure this intent.

165.01.02 Definitions - For the purposes of this Section, the following general terms are defined as follows:

a) "Appropriately Qualified Professional" means an applied scientist or technologist specializing in a relevant applied science or technology including, but not necessarily limited to, agrology, forestry, biology, engineering, geomorphology, geology, hydrology, hydrogeology or landscape architecture. An appropriately qualified professional must be recognized in British Columbia with the appropriate professional organization, and acting under that association's Code of Ethics and subject to disciplinary action by that association. He or she must also be someone who, through demonstrated suitable education, experience, accreditation and knowledge relevant to the particular matter, may be reasonably relied on to provide advice within his or her area of expertise.

b) "Construction Environmental Management Plan" means an action plan which addresses the how, when, who, where and what of integrating environmental mitigation and monitoring measures throughout an existing or proposed operation or activity. It encompasses all the elements that are sometimes addressed separately in mitigation, monitoring and action plans.

c) "Deleterious Substance or Material" is defined as a substance harmful to fish or fish habitat (Canada Fisheries Act).

d) "Designated" shall mean designated in the Special Provisions or by the Ministry Representative.

e) "Environment" refers to the physical, biological, social, spiritual and cultural components that are interrelated and affect the growth and development of living organisms. The term "environment" in these specifications shall include socio-community issues and resources.

f) "Environmental Agencies" shall mean the appropriate regulating branches of the Federal and Provincial agencies responsible for the management and protection of the Environment and human resources. A partial listing of these agencies and their areas of concern is given in the joint publication "Land Development Guidelines for the Protection of Aquatic Habitat", Fisheries and Oceans Canada and Ministry of Environment, Lands and Parks (1992), hereafter referred to as the "Land Development Guidelines" and the "Standards and Best Practices for Instream Works", Ministry of Water, Land and Air Protection (2004).

g) "Environmental Approval" is defined as the written authority issued to a person or company by a government agency that allows the person or company to do something that otherwise may not be permitted by law or which is not defined in law. An Environmental Approval is a broad, generic term referring to informal or formal authorization for actions that may have an adverse effect on the environment, such as

(i) undertaking an activity (e.g., authorization from fishery agencies to proceed with work within the wetted perimeter of a fish-bearing stream); or

(ii) discharging some form of material (e.g., approval under the British Columbia Environmental Management Act to introduce waste into the environment or the storage of special waste for a period of 12 months or less).

The term "approval" can include related forms of authorization such as permits and licenses.

h) "Environmental Monitor" shall mean an agent hired by the Contractor to ensure the Contractor's compliance with the environmental protection aspects of Standard Specifications, Special Provisions, permits and approvals, and to advise the Contractor and Ministry Representative on environmental issues and problems.

i) “Environmental Procedures” are written work procedures documenting environmental protection measures to be used to mitigate potential environmental impacts from activities in Environmentally Sensitive Areas.

j) “Environmentally Sensitive Areas” shall mean areas requiring special management and attention to protect resources, habitat or species (which includes and is not limited to water quality, identified sensitive areas, fish and fish habitat, vegetation, rare and endangered flora/fauna, landscaping and visual aesthetics, soil conservation (including dust control), air quality and archaeological, heritage and cultural resources).

k) “Environmental Timing Window” shall mean any period suitable for environmentally sensitive construction work as Designated by an Environmental Agency or other federal, provincial, municipal or local agency. This window represents the period that the natural or human environment is likely less susceptible to adverse impacts. A common example of an Environmental Timing Window on highway construction projects is a Fishery Timing Window. Timing windows may also be imposed for the protection of breeding birds, retention of significant recreational activities, maintenance of critical traffic patterns, etc.

l) “Fisheries Sensitive Zone” is defined as the instream aquatic habitats, as well as out-of-stream supporting habitat features such as side channels, wetlands, and vegetated riparian areas adjacent to these features.

m) “Fishery Timing Window” refers to the time period(s) of reduced risk for important commercial, sport, and resident fish species, based on their life histories. The Fishery Timing Window is the time of year during which there are no fish eggs or alevins present in the substrates of local Watercourses, and the period when fish migration (juvenile out-migration and adult spawning in-migration) is not occurring. This is generally the preferred period for (i) instream work or (ii) work adjacent to or over top of fish-bearing streams with the potential to create adverse impacts on fish or fish habitat. The Fishery Timing Window is that period of any given year which is at any time so Designated by the Environmental Agencies. “Fishery Timing Window” and “Instream Work Window” are synonymous.

n) “Habitats” are defined as those parts of the environment on which terrestrial and/or aquatic species depend, directly or indirectly, in order to carry out their life processes.

o) “Impact” is defined as an alteration, either positive or negative, to the environment brought about as a direct or indirect result of a highway project, including

construction, operation and maintenance work (e.g., the consequence of a highway-related activity interacting with its surroundings).

p) “Instream Work Window” and “Fishery Timing Window” are synonymous.

q) “Mitigation” refers to a procedure or an action designed to avoid, reduce or control the severity, magnitude, duration and/or frequency of environmental impacts of a project through design alternatives, scheduling or other means.

r) “Permit” refers to a formal authorization, typically granted to proponents by an Environmental Agency, for discharging agreed upon quantities and types of regulated substances such as pollutants or waste. For example, under Section 8 of the British Columbia Waste Management Act, a permit may be issued to introduce waste into the environment or to store special waste subject to environmental protection requirements which are deemed advisable. The permit can specify the procedures or requirements respecting the handling, treatment, transportation, discharge or storage of waste that the holder of the permit must fulfill. The term “permit” can be defined by applicable legislation. The term “permit” is synonymous with the term “license”, and the two terms are often used interchangeably.

s) “Riparian Area” is defined as the land adjacent to the normal high water level in a stream, river, lake or pond and extending to the portion of land that is directly influenced by the presence of adjacent ponded or channeled water, or a groundwater zone fed by surface water bodies (e.g., zone in which rooted vegetation is influenced). Riparian areas typically contain important vegetation resources which provide several critical functions for the survival of fish (e.g., protection from predators, shade for temperature regulation of the Watercourse, and sources of food).

t) “Sedimentation” is defined as the deposition of material carried in water, usually as a result of a reduction in water velocity below the point at which material can be transported.

u) “Watercourses” shall apply to all bodies of water including streams, rivers, canals, ditches, lakes, ponds, and wetlands.

v) “Wetted Perimeter” is the area of stream channel extending to the normal high water marks as is evident in the field as the boundary on the stream bank between the scoured channel and the edge of rooted vegetation, or as marked in the field by the Ministry Representative or the Environmental Monitor. It may be defined by Station number and/or as highlighted on the plan drawings.

SECTION 165

165.01.03 General Restraints for Watercourses and Groundwater - The following general restraints in regard to the protection of any Watercourse shall apply:

- a) The Contractor shall place and/or dispose of all organic material, refuse, ash, petroleum products and other deleterious materials so as not to directly or indirectly pollute any Watercourse or groundwater. The placement and disposal of all such products and materials shall be done in an environmentally acceptable manner.
- b) Except as required by the Contract Documents, all inorganic material shall be placed and/or disposed of in a manner that does not obstruct or unduly disturb any permanent or seasonal Watercourse. Any such obstruction or disturbance shall be restored to the original drainage pattern as reasonably required by the Ministry Representative. Any removal of inorganic material from a Watercourse shall be done in a manner that minimizes adverse impacts and shall be carried out as directed by the Ministry Representative.
- c) All activities within the wetted perimeter of any Watercourse shall be kept to an absolute minimum. Machinery and equipment shall not be operated within the wetted perimeter of any Watercourse other than under the authority of the Ministry Representative. An Environmental Monitor shall be present at the direction of the Ministry Representative during any work within the wetted perimeter of any Watercourse on the Project.

The preceding requirements, a) through c), are considered incidental to the price bid for work under Contract and no other compensation will be made.

165.01.04 Designated Streams and Designated Environmentally Sensitive Areas - Any Watercourse or Environmentally Sensitive Area Designated in the Special Provisions or by the Ministry Representative is subject to all of the restraints of this Section.

165.02 Environmental Monitor - The Contractor shall retain the services of an Environmental Monitor.

The Environmental Monitor shall be an independent Appropriately Qualified Professional.

The Environmental Monitor shall be suitably experienced in:

- The preparation and implementation of environmental protection plans including, but not limited to: Construction Environmental Management Plans (CEMP) for mitigating environmental impacts of highway and bridge projects, including erosion and sediment control plans, spill contingency plans, clearing and grubbing plans, reclamation plans, environmental monitoring plans;

PROTECTION OF THE ENVIRONMENT

- liaising with Environmental Agencies;
- applying for Environmental Approvals;
- fish salvage operations; and
- sampling, analysis and monitoring of water quality.

The Environmental Monitor shall be available throughout the duration of the Work to represent the Contractor in all matters related to the protection of the environment and will attend all key meetings at which environmental protection measures are to be discussed.

The Environmental Monitor and the Contractor shall work together on the development and implementation of the Construction Environmental Management Plan and associated plans and applications for Environmental Approvals.

Unless otherwise approved by the Ministry Representative, the Environmental Monitor shall be on-site during work in Environmentally Sensitive Areas including, but not limited to the following activities:

- installation and decommission of temporary stream crossings, work bridge works, construction accesses, and in-stream sediment control and isolation measures;
- fish salvage operations;
- excavations, or placement of riprap, within the Wetted Perimeter of streams;
- construction activities in and around listed species or ecosystems; and
- cement pours in and around Designated Watercourses. .

165.02.01 Planning and Scheduling - The Contractor shall carefully plan and schedule construction activities in a manner that ensures the avoidance or absolute minimization of environmental damage. The Contractor shall be familiar with and be able to identify those areas and times which present environmental problems and shall prepare schedules and work methods accordingly. The Contractor shall forward a copy of each of the schedules to the Ministry Representative at least one week in advance of commencement of each of these operations, unless otherwise specified in the contract.

165.02.02 Construction Environmental Management Plan The Contractor shall provide a Construction Environmental Management Plan (CEMP) which describes in detail the approach to be taken in addressing environmental issues associated with the Project and the correlation of the CEMP to the project schedule.

The CEMP shall be provided to the ministry prior to mobilization to the site. The Contractor shall make copy of the CEMP accessible to personnel on-site.

SECTION 165

PROTECTION OF THE ENVIRONMENT

Mandatory elements of the CEMP will include, but not be limited to, the following:

- a demonstration of work compliance with the environmental protection requirements of the Contract, including, but not limited to, the Standard Specifications, Special Provisions, and Environmental Approvals.
- a demonstration of an understanding of the specific environmental issues involved with the Project, including Environmental Approvals;
- indicate an understanding of Ministry/Contractor responsibilities;
- all the tasks required and clearly identify the duration and sequence of each task leading to the receipt of agency approvals, and its linkage to the project schedule; Environmental Procedures;
- Erosion and Sediment Control Plan;
- Spill Contingency Plan;
- Clearing and Grubbing Plan; and
- Reclamation Plan;
- Environmental Incident Reporting Plan
- Environmental Monitoring Plan identifying the Work activities during which the Environmental Monitor will be on-site; and
- Construction Waste Management Plan
- Air Quality and Dust Control Plan
- Contact names, positions and telephone numbers of individuals responsible for elements of the plan and Environmental Agency contacts.

The CEMP will clearly indicate how the Project will be undertaken to avoid negative impacts pertaining to, but not limited to, the following resources:

- water quantity and quality (including all surface and sub-surface sources),
- identified sensitive areas,
- fish and fish habitat,
- wildlife,
- vegetation (including riparian plant communities),
- rare and endangered flora/fauna,
- landscaping and visual aesthetics,
- soil conservation (including site stability, dust control),
- air quality, and
- archaeological, heritage, and cultural resources.

The Contractor, in consultation with the Ministry Representative, Environmental Monitor and the

Environmental Agencies, shall be responsible for determining the conditions under which the work must be carried out in Environmentally Sensitive Areas, and for making all required on-site examinations and examinations of documents supplied and referenced by the Ministry in order to fully comprehend the environmental aspects of the work required.

165.02.03 Environmental Procedures - The Ministry may require one or more detailed sets of Environmental Procedures for any work in and around Environmentally Sensitive Areas, such as critical fish habitat. When a set of Environmental Procedures is required, the Contractor shall prepare and submit the procedures for approval by the Ministry Representative and the Environmental Agencies prior to undertaking work in these areas. These detailed procedures shall be an element of the CEMP. The Contractor shall forward a copy of the approved set of procedures to the Ministry, prior to undertaking the work. The Environmental Procedures shall contain the following items:

- a) Existing environmental conditions. Identification of the environmental resources (e.g. fish species and habitat) in the area of the proposed work.
- b) Description of work proposed in the Environmentally Sensitive Area. Summary of the proposed work, equipment to be used, schedule of activities, and location.
- c) Environmental protection measures. Statement concerning the protective measures that will be used to protect environmental resources (e.g., species and habitat) from each anticipated adverse impact.
- d) Contingency plan. Description of alternative or backup plan in the event of an environmental emergency or failure of any of the protective measures.
- e) Environmental monitoring requirements. Indication of any specific or unique environmental monitoring requirements to ensure compliance with environmental specifications and proper implementation of the CEMP.

Environmental procedures will be required for, but not limited to, the following activities within Environmentally Sensitive Areas;

- Clearing or grubbing;
- Streambed or streambank excavation, or riprap placement in a Watercourse;
- Installation or decommissioning of temporary features such as work bridges, cofferdams, instream shoring, tote roads, or construction accesses; and
- Other activities as directed by the Ministry Representative.

SECTION 165

The Contractor shall consult with the Environmental Monitor and, if necessary, Fisheries and Oceans Canada (DFO) and the Ministry of Environment for specific recommendations about the preparation of the Environmental Procedures. The Environmental Procedures must be approved by the Ministry Representative and the Environmental Agencies prior to commencement of work in Environmentally Sensitive Areas.

165.02.04 Project Orientation and Meetings - The Contractor shall arrange regular meetings with the Ministry Representative, and the Environmental Monitor. Other interested parties may be asked to attend (e.g., Agency Representatives), whose representation is necessary because of the specific type or location of work being undertaken. The purpose of such regular meetings will be to outline the schedule of upcoming construction and proposed activities, and to review the activities of the previous week. Such regular meetings do not relieve the Contractor from attending or arranging other types of meetings as required due to the nature or extent of the work being done.

The Contractor shall arrange and conduct such regular meetings during construction, subject to the following conditions:

- a) Meetings shall be held on a weekly basis when construction activities are to proceed during an Environmental Timing Window, during a period when work is to proceed in an Environmentally Sensitive Area, or during a period when the proposed construction activity elsewhere on a project is to proceed for a duration greater than two weeks and has the potential to cause adverse environmental impacts.
- b) During periods other than that specified above, regular environmental meetings shall be held every two weeks, or as otherwise agreed to by the Ministry Representative.
- c) In the event that the Environmental Monitor or the Ministry Representative deem the Contractor's compliance regarding environmental requirements to be inadequate at any time during the Project, the frequency of the weekly or biweekly regular meetings shall be increased accordingly until the Environmental Monitor and the Ministry are satisfied with the Contractor's compliance rate.
- d) The Contractor's Environmental Monitor will record highlights from the meetings (e.g., summary of major discussion items and key action items) and forward a copy to the Contractor, as well as include this material in the Project Environmental Progress Reports.
- e) During the maintenance phase of the Project, the Contractor shall conduct regular environmental meetings with the Environmental Monitor on a

PROTECTION OF THE ENVIRONMENT

quarterly basis, unless operations are to be conducted within Environmentally Sensitive Areas that pose potential environmental concerns. In the event that operations are to be conducted within such areas, the Contractor and Environmental Monitor shall conduct weekly environmental meetings for the duration of the maintenance work in such areas.

The Contractor is responsible for ensuring that the foreman, operators, and work crews (including any subcontractors) understand the specific environmental issues on the work site and their responsibilities under this Section. The Contractor's Environmental Monitor will give all construction personnel a brief environmental orientation prior to such personnel commencing work in any Environmentally Sensitive Area on the Project. The Contractor's Environmental Monitor will ensure that construction personnel are familiar with the environmental requirements and acceptable construction practices on the Project. The Contractor shall support the Contractor's Environmental Representative's role in this regard.

165.02.05 Activity Within Designated Watercourses and Environmentally Sensitive Areas - All activities that are conducted within the wetted perimeter of any Designated Watercourse or within other Designated Environmentally Sensitive Areas must conform to the timing restrictions stated in the Special Provisions, and to the Environmental Timing Windows given in the approvals of the Environmental Agencies. Construction work must be scheduled so that all operations affecting the Fisheries Sensitive Zone or other Designated Environmentally Sensitive Areas can be completed within these time periods. Prior to the commencement of any construction activities, all work in these areas must be approved by the Environmental Agencies and the Ministry Representative.

The Contractor must give at least 48 hours notice to the Ministry Representative in advance of any construction-related activity in Designated areas. Construction activities within Designated Watercourses or other Environmentally Sensitive Areas shall not commence without the approval of the Environmental Monitor.

165.02.06 Inclement Weather - The Contractor shall cease operations, modify construction methods, or relocate to an alternative site within the project area during periods of inclement weather to avoid siltation of Designated Watercourses. If the Ministry Representative judges that the Contractor is not complying with the intent of this Section, the Ministry Representative may direct the Contractor as to measures required without additional compensation for delays or alterations in the Contractor's work.

165.02.07 Work Stoppage - Prior to initiating work stoppages, the Contractor shall initiate and complete any mitigative and environmental protection measures required

SECTION 165

to safeguard the environment and the Project during work stoppages.

The Contractor shall give the Ministry Representative sufficient notice of impending shutdowns to enable the Ministry Representative, Contractor, and, if employed, the Environmental Monitor to examine the project. This notice shall be sufficient to permit the Contractor adequate time to install all necessary additional environmental mitigation measures as may be directed by the Ministry Representative.

The Contractor shall ensure the Environmental Monitor and construction personnel inspect Environmentally Sensitive Areas on the Project on a regular basis during any extended work stoppages (e.g., weekends, statutory holidays, Christmas vacation periods) to prevent environmental problems. If potential adverse environmental impacts are observed during work stoppage periods, the Contractor shall initiate and undertake any required environmental measures to avoid or minimize impacts.

165.03 Compliance, Enforcement and Payment

165.03.01 Compliance with Specifications - The Contractor is responsible for ensuring that all subcontractors and employees are in compliance with these Specifications and all applicable environmental legislation and regulatory requirements at all times, and shall take immediate action to rectify problems in this regard. The Contractor shall initiate action to rectify environmental problems within the time period as specified by the Ministry Representative. The Contractor shall have available such additional safeguards, safety devices and protective equipment as are necessary to protect the environment. The Contractor shall be responsible for ensuring sufficient safety devices and protective equipment (e.g., pumps, silt fence, armoring, tarps, fuel spill cleanup kits, etc.) are readily available at all times during construction of the Project. The location and inventory of safety devices and protective equipment shall be documented and placed in a prominent location in the Contractor's field office. A copy of this information shall be updated as necessary and provided to the Ministry Representative.

The Environmental Monitor shall inspect and monitor conditions at, and in the vicinity of, the project to ensure acceptable levels of pollution and disturbance are not exceeded, and to ensure compliance with the environmental specifications contained herein and in the Special Provisions.

The frequency of such inspection and monitoring efforts shall correspond to the sensitivity and location of construction activities, as well as to the environmental conditions (e.g., increased monitoring and inspection will be conducted during periods of inclement weather). In the event that the Ministry Representative is not satisfied with

PROTECTION OF THE ENVIRONMENT

the frequency and duration of such inspection and monitoring, the Contractor and/or the Environmental Monitor will be required to increase their efforts in this regard to a level satisfactory to the Ministry.

165.03.02 Compliance with Environmental Legislation and Regulatory Requirements - The Contractor shall observe and comply with all federal, provincial, municipal and local laws and regulations which seek to ensure that construction work does not adversely affect the environment or social-community resources.

In the event of conflict between the requirements set out in these Specifications and quality control laws, statutes, regulations and ordinances of federal, provincial, municipal or local agencies, the more restrictive requirements or regulations shall apply. A violation of the environmental laws and regulations reported to the Ministry by the responsible agencies may result in the issuance of a non-conformance report. Should the situation warrant more stringent measures, it may also result in the issuance of a stop-work order until the violation is corrected. The Contractor shall have no recourse for reimbursement due to delays or alterations to construction activities arising from such violations or the correction of such violations.

The Contractor shall observe and comply with all terms and conditions of Environmental Approvals. Unless otherwise indicated, the Contractor is responsible for all work needed to comply with the terms and conditions of Environmental Approvals. The Contractor shall make copies of all Environmental Approvals accessible to personnel on-site.

165.03.03 Temporary Pollution Control - The Contractor shall be responsible for implementation of any temporary environmental protection measures, such as pollution control measures. If the Contractor fails to respond to this requirement or to the instructions in this regard from the Ministry Representative or the Environmental Monitor within directed time span, the Ministry Representative may take whatever action is necessary to provide the proper corrective measures. In the event the Contractor fails to take reasonable action to implement temporary environmental control measures, the Ministry's Representative shall determine the need for additional corrective action. The Ministry's Representative may deduct incurred costs from any money due or to become due to the Contractor for any corrective action taken in this regard.

165.03.04 Responsibility for Damage to Environment - The Contractor shall bear sole responsibility for any direct or indirect damage to the environment which occurs as a result of failure to comply with Environmental Approvals, these Specifications, the directions of the Ministry Representative or recommendations of the Environmental Monitor.

165.03.05 Stop Work Orders - In the event that the Ministry Representative determines that some aspect of the construction is creating or will result in a substantial adverse effect on environmental values or resources on or adjacent to the project site, the Ministry Representative may issue a "stop work order" on behalf of the Ministry. The Contractor shall subsequently be responsible for advising the Ministry Representative of the intended remedial action. The Ministry Representative may direct the Contractor to cease construction work on an unaffected portion of the site so that any necessary equipment can be immediately diverted to address the environmental emergency. In such an event the Contractor will not be entitled to any claim for compensation from the Ministry.

In the event that an Environmental Monitor is employed, and the Ministry Representative cannot be contacted, the Environmental Monitor will assume the Ministry Representative's role regarding Stop Work Orders, as detailed above, until such time as the Ministry Representative can be contacted. The Environmental Monitor will fully document all such instances. In such an event, the Contractor will not be entitled to any legal recourse or claim for compensation from the Ministry.

The Contractor shall be required to modify or halt any aspect of construction or maintenance that the Environmental Agencies determine poses or will pose an environmental concern. The Environmental Agencies may verbally direct the Contractor to modify or halt any such activity or submit formal written instructions to that effect. In either case, the Contractor's immediate compliance with their instructions will be mandatory. The Contractor shall document any such requests by the Environmental Agencies and forward a copy of this documentation to the Ministry within five working days of the initial notification by the Agencies.

165.03.06 Payment - All other requirements for compliance with these environmental specifications shall be considered incidental to the price bid for the Project under contract and no other compensation shall be made to the Contractor. However, the Contractor may be eligible for reimbursement for the installation of any additional environmental works (e.g., enhancement measures) where directed and approved in writing by the Ministry Representative and not covered in this Section or elsewhere in the Special Provisions or Schedule of Quantities and Unit Prices. Any eligible reimbursement will be paid for by an Order for Extra Work. The Ministry Representative will be responsible for determining the Contractor's eligibility in this regard and for identifying what environmental work is beyond the scope of the Contract and these specifications.

165.04 Erosion, Sediment, and Drainage Control - All works shall be undertaken in a manner that avoids or absolutely minimizes erosion problems and the discharge of siltation or other deleterious substances into any

Watercourse. The Contractor shall not disturb Designated Watercourses, unless the express written consent of the Environmental Agencies is obtained prior to initiating construction activities in such areas. No obstruction or debris shall be placed in any Watercourse during any operations, unless specified in the Special Provisions or by the Ministry Representative, or for Designated Watercourses approved by the Environmental Agencies. Should any material be inadvertently placed within the normal high water wetted perimeter of a Watercourse, the Ministry Representative shall be notified immediately and the Contractor shall remove the material immediately, using environmentally acceptable construction procedures and under the direction of the Environmental Monitor.

165.04.01 Erosion and Sediment Control Plan (ESCP)

– The Contractor is responsible for preparing and implementing an ESCP for the project in accordance with the methodology of the "National Guide to Erosion and Sediment Control on Roadway Projects", Transportation Association of Canada 2005. The Contractor shall incorporate all permanent soil erosion control features into the project at the earliest practicable time, as outlined in the accepted work schedule, and shall be responsible for temporary erosion and sediment control measures, including daily inspection of the integrity of such measures during adverse weather conditions or when construction operations are proceeding in Environmentally Sensitive Areas. Control measures shall be capable of continuous operation during working and non-working hours, and are subject to approval by the Ministry Representative. Any deficiencies which are observed in erosion control measures shall be immediately corrected.

The Ministry Representative has the authority to define Environmentally Sensitive Areas or conditions, such as areas of erodible soil, and to direct the Contractor to provide temporary erosion and sediment control measures. These measures may include, but may not be limited to:

- interceptor ditches or berms to direct runoff away from erodible areas;
- slope protection measures such as mulches, hydroseeding, erosion mats, geotextiles, filter fabric, polyethylene covers, or riprap;
- silt fences;
- ditch blocks to reduce flow velocities, and;
- sediment control measures, such as settling ponds.

The Contractor shall have sufficient materials, such as clean rock, granular material, and filter fabric available on-site for emergency protection measures when required.

The Contractor shall regularly maintain sediment and drainage control measures, such that they function as designed. Immediate action shall be taken by the Contractor to correct any deficiency observed in the operation of erosion and sediment control measures. In

SECTION 165

the event that a deficiency in any sediment or drainage control measures is directly or indirectly creating an adverse environmental impact, the Contractor shall initiate the necessary action to correct the problem within one hour of observing or being informed of the situation. In the event that a deficiency in any sediment or drainage control measures poses the potential to create an adverse environmental impact, the Contractor shall take action within two days of observing or being informed of the situation. In the event that environmental conditions or the status of the situation change in regards to a potential deficiency, the Contractor shall accelerate any proposed correction measure(s) by taking immediate action (i.e., within one hour). The judgment of the need and timing for corrective action in regard to sediment or drainage control measures shall be at the discretion of the Ministry Representative, Environmental Monitor, and the Environmental Agencies.

Sediment and debris accumulations which compromise the functioning of the erosion and sediment control measures shall be removed by the Contractor and disposed of in an environmentally acceptable location and manner. At a minimum, silt fence structures shall be cleaned when sediment accumulation heights exceed 30 cm along any portion of the structure.

In the absence of site-specific requirements from the Fisheries and Oceans Canada or the British Columbia Ministry of Environment, the Contractor shall comply with criteria for suspended solids in runoff water from the site as agreed upon prior to construction by the Ministry Representative and Environmental Agencies.

Sediment and drainage control methods are detailed in the "National Guide to Erosion and Sediment Control on Roadway Projects" and the "Land Development Guidelines", the "Standards and Best Practices for Instream Works and the Ministry publication "Control of Erosion and Shallow Slope Movement". Compliance with the spirit and intent of these guidelines is mandatory. The determination of the Contractor's compliance with these guidelines shall be at the discretion of the Ministry Representative and Environmental Agencies.

The Contractor, as directed by the Ministry Representative and in consultation with the Contractor's Environmental Representative, shall be responsible for the preparation and implementation of any Plan(s) required for the Project. Such plans will form an essential component of the Contractor's environmental protection program, in terms of identifying environmentally acceptable construction practices for erosion and sediment controls at specific sites. The Erosion and Sediment Control Plan(s) will be subject to, but not limited to the following requirements:

- Prior to commencement of construction activities on the Project and thereafter when deemed necessary, the Contractor and the Environmental Monitor will identify areas and major construction activities for

PROTECTION OF THE ENVIRONMENT

which the Contractor will be required to prepare one or more Erosion and Sediment Control Plans. Designation of these areas and activities will be done in consultation with the Environmental Agencies and the Ministry Representative.

- In addition to activities within the Project area, a Erosion and Sediment Control Plan shall be submitted for activities related to the Contractor's work in areas away from the project that have the potential to create adverse environmental impacts, which will be determined by the Contractor in consultation with the Environmental Monitor, the Environmental Agencies and the Ministry. These activities are not confined to the areas immediately adjacent to the right-of-way, but also in other locations in which the work or associated activities will be conducted, including but not limited to haul or access roads, temporary structures, borrow and granular excavations, staging/laydown areas, material storage sites and disposal sites.
- The Contractor shall not commence work in any area so identified until a Erosion and Sediment Control Plan has been submitted and accepted by the Ministry and involved Environmental Agencies.
- The acceptance and approval of the Contractor's Erosion and Sediment Control Plan or updated Plan shall be valid only so long as the conditions and anticipated conditions upon which the Plan and its acceptance were based continue to be applicable.
- The Contractor shall at all times be responsible for ensuring that work is carried out in accordance with a Erosion and Sediment Control Plan or updated Plan, which has been accepted by the Ministry and Environmental Agencies.
- The Ministry or the Environmental Agencies may request the Contractor to update and resubmit its plan(s) at any time, and may require the Contractor to cease work until the update(s) has been submitted and accepted. Whether or not the Ministry or the Environmental Agencies so request, the responsibility for carrying out the work in accordance with a validly accepted Plan lies entirely with the Contractor.
- The Ministry or the Environmental Agencies may order the Contractor to stop work or to take other precautionary or remedial measures whenever the Contractor is carrying out any work that is not in accordance with a Erosion and Sediment Control Plan or updated Plan which has been accepted by the Ministry or the Environmental Agencies, and for which that acceptance is still valid. All costs of any resulting delay shall be borne entirely by the Contractor.

SECTION 165

At a minimum, a Erosion and Sediment Control Plan will include the following information and will be prepared in a format satisfactory to the Ministry Representative and the Ministry:

- a) A schedule for the proposed activities, as they pertain to the Erosion and Sediment Control Plan and construction staging, including anticipated duration of construction.
- b) A description of the construction procedures that will be used to limit the potential for erosion and sediment production, including estimates of work areas where applicable (e.g., volume of material in a proposed stockpile site), description of construction equipment to be used, and staging of operations.
- c) A detailed description of the site-specific measures for runoff and drainage management.
- d) A detailed description of the site-specific mitigation measures and design information for erosion prevention and control (e.g., sizing of culverts, ditches or sediment/detention ponds, silt fence specifications, and description of ditching and berming).
- e) A schedule that identifies the various sloped areas by station and the dates in which they will be protected using temporary and permanent revegetation measures, such as hydroseeding.
- f) A detailed description of mitigative measures for ensuring acceptable water quality and quantity at points of discharge to Watercourses, including sizes and specifications for any proposed water treatment facilities.
- g) A key plan and drawings, in suitable scale and detail, of the site and proposed mitigative measures and applicable construction procedures.
- h) A written commitment of on-site equipment (e.g., water pumps) and materials (e.g., silt fence, hay bales, rock armoring, and ditch breakers) for erosion, sediment and drainage control to deal with emergency situations that may arise.
- i) A written commitment of on-site equipment and staff to handle any fish salvage and transfer operations, if required.

A description of the specific monitoring procedures prior to, during and after completion of construction activities at this site.

165.04.02 Not used.

165.04.03 Sediment Control Ponds - The Contractor shall construct sediment control ponds where necessary to prevent the release of unavoidably entrained sediments in runoff from the construction site, and shall construct stormwater detention ponds for the temporary and/or permanent control and discharge of stormwater runoff.

PROTECTION OF THE ENVIRONMENT

The Contractor shall provide designs for and construct sediment control ponds, as well as stormwater detention ponds, on a site-specific basis in a manner that conforms to the "National Guide to Erosion and Sediment Control on Roadway Projects" or "Land Development Guidelines", other than for the following exception(s):

- Sediment control ponds and dry or wet stormwater detention ponds shall be designed and constructed to accommodate the 10-year return period storm under developed conditions with a minimum 0.60 metre freeboard to the top of the berm.

The Contractor is referred to Section 3 of the "Land Development Guidelines" for other pond design criteria and Section 8 of that publication, for sample calculations for water flows and pond sizes.

If during construction the settlement pond is filled to capacity and is still required for sediment control, accumulated settled sediments shall be removed from sediment control ponds and stormwater detention ponds. Such sediments shall be disposed of in an environmentally acceptable location and manner.

165.04.04 Maintenance of Drainage Patterns - Except where interceptor ditches or berms are required to divert sediment laden runoff from the site to a sediment control pond, original drainage patterns shall be maintained throughout construction operations. Interceptor ditches or berms shall be constructed to divert water entering the site away from erosion prone areas. The Contractor will not rely on drainage courses or conduits being shown on the Drawings, and will make whatever investigation is necessary. Where a natural Watercourse traversing the construction site crosses this interceptor ditch or berm, an armoured or lined ditch or a culvert shall be installed in order to pass accumulated flows through or around the construction site in a manner that maintains the natural runoff pattern, unless otherwise directed by the Ministry Representative.

All ditches constructed for interception of clean water outside the work site(s) to divert it around the work site(s) and for collection of treated water from the work site(s) shall be designed and constructed to accommodate the 10-year return period storm with a 0.3 m freeboard under developed conditions. Temporary and/or permanent drainage ditches, including those constructed for erosion and sediment control shall be designed to prevent high water velocities and erosion by including measures such as check dams, drop structures or erosion-resistant liners or armoring.

165.04.05 Storm Drainage Systems - In order to minimize siltation, the Contractor may be required to block storm drain inlets, or to activate inlets by means of sandbags, berms or swales, as circumstances require, or at the direction of the Ministry Representative. Berms shall be constructed of clean, non-erodible granular material.

The Contractor shall maintain, on a regular basis, any inlets activated during the course of construction. Any deficiencies noted in these works shall be corrected immediately in the event that the inlet is plugged and within the same day if the site is relatively dry.

The Contractor shall ensure adequate inspection and correction of any storm drainage system deficiencies for sites within the influence of the Project. During periods of inclement weather, the Contractor shall ensure project staff inspect storm drainage systems throughout the day, and if necessary, make arrangements for inspection and maintenance during regular work stoppage periods, such as evenings or weekends. At a minimum, such inspections shall be carried out at the start of the regular workday, at mid-day in the workday, and one hour prior to end of the regular workday. Furthermore, in the event of flooding problems, the Contractor shall be responsible for any damages or compensation resulting from impacts on residences or businesses caused by a failure or deficiency in the Contractor's design and maintenance of the storm drainage system.

During concrete curb and gutter construction, road surface runoff shall be directed by berms or swales away from concrete which has been poured within the previous 48 hours.

165.05 Clearing and Grubbing Plan (CGP)

The Contractor is responsible for preparing and implementing a detailed CGP for the project. The Contractor shall prepare the CGP in consultation with the Environmental Monitor and the Ministry Representative. The Contractor will obtain approval for this plan from the Environmental Monitor and Ministry Representative and any necessary tree removal permits from the Ministry of Forests and/or municipal agencies prior to initiating any clearing and grubbing operations within 50 m of any Designated Watercourse or Environmentally Sensitive Area.

165.05.01 Limits for Clearing and Grubbing - Clearing and/or grubbing shall extend only to the Designated limits, as defined in the Contract Drawings and marked on site. Prior to clearing or grubbing, marked limits will be inspected by the Ministry Representative, who may amend them. The Contractor may be required to use close-cut, no grub practices (i.e., cutting trees at ground level and not removing root system) or undertake hand clearing at environmentally sensitive sites, as Designated in the Special Provisions or by the Ministry Representative.

The Contractor shall minimize ground disturbance in the vicinity of any Watercourse or Environmentally Sensitive Area, and shall not proceed with clearing and grubbing closer than 50 m from a Designated Watercourse or Environmentally Sensitive Area prior to marking the limits of the Fisheries Sensitive Zone or Environmentally Sensitive Area. The width of these zones, if not specified

in the Special Provisions, will be determined by the Ministry Representative in consultation with the Environmental Agencies. The Contractor shall mark the limits of any Fisheries Sensitive Zone or Environmentally Sensitive Area, such as orange flagging tape or orange snow fence, at a minimum height of 1.5 m.

All clearing and grubbing activities in this zone must be granted prior approval by the Environmental Agencies. The Contractor shall not conduct approved grubbing operations within this zone until ready to proceed with earthwork and stabilization.

In areas near Designated Watercourses or other Environmentally Sensitive Areas determined by the Ministry Representative to be of high erosion or siltation potential, the surface area of erodible soil exposed at one time may be limited by the Ministry Representative. This will supersede SS 200.03 and SS 200.04. The Ministry Representative may confine grubbing to an area where excavation and earthwork is to be actively conducted within approximately 30 days following the completion of grubbing operations. In the event that a highway project consists only of clearing and grubbing operations, the cleared ground shall be protected and able to withstand specified periods of inclement weather.

165.05.02 Protection of Vegetation - The Contractor shall protect all vegetation growing outside of the Designated and marked areas for clearing and grubbing, as specified in SS 769 "Protection and Retention of Vegetation", with the exception of danger trees, which must be hand-felled and removed with minimum disturbance to retained vegetation.

165.05.03 Clearing Activities - Falling of timber into a Watercourse is prohibited except in situations in which safety considerations dictate otherwise or unless approved by the Environmental Monitor. Any trees or large pieces of woody debris that accidentally fall into a Watercourse and require removal shall be removed in a manner that minimizes the disturbance of the Watercourse and adjacent banks, and is approved by the Ministry Representative. Skidding of logs across Watercourses will not be permitted. The Environmental Monitor must be present during removal of any large woody debris or trees from Watercourses.

165.05.04 Disposal of Combustible Materials - The Contractor shall comply with the Forest Act and the Open Burning Smoke Control Regulation under the British Columbia Environmental Management Act. For additional information regarding the regulation, the Contractor should contact regional staff in the British Columbia Ministry of Environment office and the Fire Centre staff in the British Columbia Ministry of Forests.

The Contractor shall prevent heat or smoke damage to all vegetation that has been Designated for preservation. The use of waste oil and/or tires as fire accelerators shall not be

permitted. The Contractor may be required to use a forced air method of burning. Burning piles shall not be located within 50 m of any Watercourse, wetland or other Environmentally Sensitive Area, or in areas where ditches are to be constructed without written approval of the Ministry Representative.

In situations in which the material generated as a result of clearing and/or grubbing may not be burned on site, the Contractor shall dispose of it in a manner approved by the Ministry Representative who may require approval of the British Columbia Ministry of Environment.

165.06 Stripping Operations

165.06.01 Exposure of Erodible Earth - In areas where erosion or siltation is anticipated, the duration of exposure of erodible earth material shall be minimized. In such cases the surface area of erodible earth material exposed at one time shall be determined and approved in writing by the Ministry Representative. (See SS 165.05.01 Limits for Clearing and Grubbing)

165.06.02 Placement of Stripped Material - The Contractor shall avoid placement of stripped materials on lands within the Agricultural Land Reserve and in areas adjacent to Watercourses or other Environmentally Sensitive Areas. Erosion and sediment control measures must be taken prior to and after placement of stockpiles of stripped material in areas where natural drainage or storm water could erode the stockpile and thereby transport pollutants to surface waters. The location of stockpiles and erosion control measures must be approved by the Ministry Representative prior to placement of stripped materials and may be specified in the Special Provisions. The Contractor shall ensure that all stockpiles are stable.

Polyethylene sheeting or other suitable tarp material shall be used to cover temporarily exposed steep surfaces or stockpiles of erodible materials, such as topsoil, sand, gravel or roadbase fill. The Contractor shall ensure such erodible materials are properly covered with sheeting or suitable tarp materials immediately after creation of any temporary stockpiles. Such sheeting or tarp materials shall be examined and maintained on a regular basis. The sheeting or tarp materials shall be sufficiently anchored to prevent displacement by winds.

165.06.03 Slope Protection - The Contractor shall employ suitable techniques to prevent the initiation of surface soil erosion and movement of sediments from slopes, particularly those exposed as a result of clearing, grubbing and stripping operations. Acceptable techniques and conditions of implementation of erosion and sediment control measures for slopes are outlined in the "National Guide to Erosion and Sediment Control on Roadway Projects", Section 3 (i.e., entitled "Slope Protection and Surface Protection") of the "Land Development Guidelines" and the MoT publication "Manual of Control of Erosion and Shallow Slope Movement". Compliance

with the requirements specified in this Section, as well as any Authority/MoT manual(s) developed specifically for the Project, will be mandatory.

165.07 Earthwork Operations (Subgrade Construction)

165.07.01 Excavation and Disposal of Waste or Surplus Material - The creation and use of any site on Crown or private lands for the placement and disposal of waste or surplus material requires prior approval from the Ministry Representative and may require the approval of the Agricultural Land Commission or representatives of British Columbia Ministry of Forests and Range and other Environmental Agencies. Unless another time period is specified in the Special Provisions or by the Ministry Representative, not less than fifteen days prior to disposing of any waste or surplus material, the Contractor shall submit to the Ministry Representative for approval, a proposal delineating the locations and extent of the areas in which the Contractor intends to dispose of such material. The proposal shall describe the nature of the material and the methods to be employed in material placement, stabilizing and site revegetation. If a disposal site is required off the right-of-way, the proposal shall also indicate the procedures for any required land clearing activity. The proposal will be reviewed by the Ministry Representative who may consult with Environmental Agencies. No waste or surplus material shall be disposed of until the proposal has been approved. All work shall be done in accordance with the approved proposal.

All waste disposal sites shall be selected such that spoil is prevented from entering any Watercourse. The excavated material shall be properly drained, spread and trimmed to a stable slope not exceeding 1.5 to 1, in a manner which minimizes disturbance of Watercourses and vegetated areas. All waste sites shall be revegetated immediately after creation of the waste disposal site, or else suitable temporary erosion control measures, such as tarps, shall be used until revegetation is undertaken. The Contractor is responsible for ensuring that revegetation is successfully accomplished unless otherwise specified in the Special Provisions.

165.07.02 Work in Areas of High Water Table - Work in areas of high water table shall be scheduled to proceed during dry weather periods unless otherwise specified in the Special Provisions. The Contractor shall adopt all necessary mitigation measures to avoid or minimize adverse impacts in such areas.

165.07.03 Drilling and Blasting - Blasting operations shall be conducted in a manner that minimizes the disturbance of residences, businesses and public infrastructure (e.g., schools and churches) and to aquatic and terrestrial habitats and organisms due to shock waves, noise and vibration.

The Contractor shall not conduct blasting within 400 m of fish habitat without the approval of the blasting plan by the Fisheries and Oceans Canada; British Columbia Ministry of Environment, Fish and Wildlife offices and the Ministry Representative. The Environmental Agencies and the Ministry Representative may require the Contractor to undertake mitigative measures such as scheduling of works in Timing Windows given by the Environmental Agencies, smaller staggered blasts or use of blasting mats to minimize impacts, and hydro-acoustic monitoring. Vibrations and shock waves in fisheries habitat resulting from blasts shall comply with the Fisheries and Oceans Canada "Guidelines for the Use of Explosives in or Near Canadian Fisheries Waters".

Blasting operations shall be controlled to minimize the entry of fly rock into Watercourses or adjacent to the right-of-way, particularly in an urban setting. If required by the Environmental Agencies, the Contractor shall comply with the Agencies' directions in removal of fly rock from Watercourses and Environmentally Sensitive Areas at no cost to the Ministry.

When blasting is to be conducted adjacent to or in a Designated Environmentally Sensitive Area, the Contractor shall provide at least 24 hours notice of each blast to the Ministry Representative. The Contractor shall provide at least 24 hours written notice to those individuals or groups potentially affected by shock waves, noise and vibration from blasting operations.

165.07.04 Pile Driving - Pile Driving operations shall be conducted in a manner that minimizes the disturbance of residences, businesses and public infrastructure (e.g., schools and churches) and to aquatic and terrestrial habitats and organisms due to shock waves, noise and vibration.

The Contractor shall not conduct pile driving within or near fish habitat without the approval of the Environmental Procedures by the Fisheries and Oceans Canada; British Columbia Ministry of Environment, and the Ministry Representative. The Environmental Agencies and the Ministry Representative may require the Contractor to undertake mitigative measures such as scheduling of works in Timing Windows given by the Environmental Agencies, smaller staggered pile driving or use of bubble curtains to minimize impacts, and hydro-acoustic monitoring. Vibrations and shock waves in fisheries habitat resulting from pile driving shall comply with the Fisheries and Oceans Canada and BC Marine and Pile Driving Contractors Association "Best Management Practices for Pile Driving".

The Contractor shall provide at least 24 hours notice of pile driving activities to the Ministry Representative. The Contractor shall provide at least 24 hours written notice to those individuals or groups potentially affected by shock waves, noise and vibration from pile driving operations.

165.08 Borrow and Sand / Gravel Pits - All Borrow and Sand/Gravel pit locations, operations, reclamation and revegetation shall comply with the Ministry of Energy and Mines / MoT / Natural Resources Canada joint publication "Reclamation and Environmental Protection Guidelines for Sand, Gravel and Quarry Operations in British Columbia".

165.08.01 Control of Drainage - Prior to borrow excavations, or quarry, sand or gravel pit development, all surface water entering the site shall be controlled so that its entrance into the operating area is prevented. Drainage shall be controlled throughout borrow operations in order to prevent natural drainage and surface runoff from carrying sediment into adjacent Watercourses. The Contractor shall prepare an Erosion and Sediment Control Plan (see SS 165.04.02) prior to the creation and/or operation of any borrow excavations or quarry, sand or gravel pit development sites. The Contractor shall also prepare a Reclamation Plan.

165.08.02 Location and Development of Borrow and Sand/Gravel Pits - Clearing for borrow and sand/gravel pits shall comply with SS 165.05 - Clearing and Grubbing. All organic strippings topsoil shall be stockpiled for future reclamation.

Borrow excavations shall not be located in the wetted perimeter of a Watercourse or on a stream floodplain at a location likely to create a new channel to the stream at a time of flooding, without the approval of the Environmental Agencies. Borrow sources located within 100 metres of the wetted perimeter of a Watercourse or at distances less than 100 m from any water-impounding dyke or dam embankment will require the design of a Professional Engineer or Professional Geologist. Final floor elevations shall be sufficiently high that they will not be subject to fluctuations in the groundwater table.

In erosion-prone areas, overburden removal shall be restricted to an area that will be excavated within one year. The open face(s) of the borrow pit should be no larger than necessary for efficient pit operation. Material should be exhausted at one location in a pit prior to the opening of a new face to remove a similar type and grade of material.

The Contractor shall be responsible for maintaining the functionality of erosion, sediment and drainage control measures within and around borrow and sand/gravel pits throughout all phases of overburden and material removal, as well as during periods of work stoppages. Borrow and/or sand/gravel pits shall be rehabilitated and decommissioned in an environmentally acceptable manner and to the satisfaction of the Ministry and the Environmental Agencies.

To minimize the spread of noxious weed seeds between construction sites and gravel pits/quarries, all crushing equipment and mining vehicles must be cleaned with a power/high pressure washer (manually cleaned in freezing

temperatures), before entering any MoT pit or quarry. If the pit contains noxious weeds the crushing equipment and mining vehicles must also be cleaned with a power/high pressure washer (manually cleaned in freezing temperatures) before leaving the pit/quarry. Prior to the production of aggregates the pit floor, crusher/plant location, equipment-parking area, stockpile site(s), pit face(s) and area to be mined will be inspected by the Contractor for the presence of noxious weeds. If noxious weeds are present they must be removed mechanically by the contractor. Noxious weeds are defined as non-native plants species listed in the Weed Control Act.

165.08.03 Washing Operations - In locations where siltation of a fish-bearing Watercourse may occur, approval shall be obtained from the Environmental Agencies prior to the establishment of aggregate washing operations, and all wash water shall be subject to SS 165.04. Where possible the Contractor may be directed by the Ministry Representative to use water from pit dewatering or clarified water from the sediment pond(s) in the wash plant.

Waste or surplus material shall be disposed of at a waste disposal site approved by the Ministry Representative. The Contractor shall create and designate, with appropriate signing, suitable sites and facilities for disposal of waste or surplus material. In particular, the disposal of deleterious materials, such as surplus concrete or concrete wash water in sites other than those approved by the Ministry Representative and the Environmental Agencies is prohibited. The Contractor and the Contractor's Environmental Monitor shall be responsible for ensuring all construction personnel, including subcontractors, are made aware of this requirement. In the event that it is not feasible to install a suitable concrete waste disposal site immediately adjacent to the work site, such as during a concrete pour on a long bridge deck, then the Contractor shall take the necessary precautions to isolate the work site from any Watercourse or other Environmentally Sensitive Area and to temporarily collect the concrete waste or wash water and transport it to a nearby suitable disposal facility. The Contractor shall notify and seek approval from the Ministry and the Environmental Agencies for any changes in the location of waste disposal sites during construction operations.

165.09 Detour, Access and Haul Roads

165.09.01 Design, Construction and Operation of Access Roads - Any temporary access, detour and/or haul roads, including associated lay-down or staging areas, associated with the project shall be constructed to accommodate all required uses and maintained throughout the course of construction operations in a safe, environmentally sound manner.

The location, alignment, design and construction of all detour, access and haul roads shall be subject to the approval of the Ministry Representative, and the

appropriate Environmental Agencies. The Contractor shall be responsible for applying for and acquiring Environmental Approvals for access roads not previously identified in Environmental Approvals acquired by the Ministry.

Clearing shall extend no further than safe operation requires, or to the edge of cut or toe of fill. Root systems of cleared vegetation shall not be removed except in the area of cuts or actual road surface.

The Contractor shall employ suitable measures to maintain air quality, visibility, and safe conditions in the use of access, detour and/or haul roads associated with the Project.

165.09.02 Drainage and Erosion Control - Drainage structures shall be incorporated into and maintained for the duration of the project along all detour, access and haul roads to minimize erosion and maintain drainage patterns.

165.09.03 Abandonment - The Contractor shall winterize haul and access roads at the end of the construction season and shall ensure proper drainage control measures are in place. Culvert inlets and outlets shall be flagged. During periods of work stoppages, the Contractor shall ensure sufficient inspection and maintenance of the access, detour and/or haul roads such that adverse environmental impacts are avoided or minimized. In the event that potential or existing environmental problems are identified by the Contractor, its staff, the Ministry, the Environmental Agencies or the public, the Contractor will take immediate steps to rectify the problem and ensure corrective action is taken to prevent future recurrence of similar problems.

When no longer required by the Contractor or the Ministry, construction roads shall be properly decommissioned, including measures such as blocking such roads off from vehicular traffic, scarifying the compacted surfaces and revegetating the area as stipulated in Environmental Approvals.. All drainage and crossing structures shall be removed, and sufficient cross ditches and ditch blocks constructed and stabilized to restore the original drainage patterns and prevent erosion. The Ministry Representative may require that windrows along the side of the road be removed, and the road surface sloped to drain in the direction of the surrounding contours. Fill may be required to be pulled back onto the road if it is judged to be unstable. Remaining cut slopes shall not exceed the natural angle of repose. Reclamation works required by the Ministry Representative may include, but may not be limited to decompaction of the road surface, revegetation of exposed soil surfaces, and reforestation.

165.10 Instream Works - In general the Contractor shall comply with the requirements specified in the applicable sections of "Standards and Best Practices for Instream Works", "A Users' Guide to Working in and Around Water" as well as those requirements noted below. The

Contractor, in consultation with the Environmental Monitor, shall prepare a detailed set of Environmental Procedures for any work within a Fisheries Sensitive Zone, within the wetted perimeter of any fish-bearing Watercourse (or any Watercourse that flows directly into a fish-bearing stream), or for any work with the potential to cause major adverse impacts on a fish-bearing Watercourse (e.g., concrete pour for a bridge deck over a fish-bearing Watercourse, hydroblasting of bridge substructures over a fish-bearing Watercourse, etc.).

No clearing or equipment operation shall take place in a Fisheries Sensitive Zone prior to Ministry and environmental agency approvals. Waste material generated during instream works shall not be stored or dumped within the floodplain unless otherwise approved by the Ministry Representative.

Drainage of waterbodies, such as wetlands, swamps or beaver ponds, shall be subject to the approval of the Ministry Representative who will consult the Environmental Agencies, unless drainage of these areas is specifically required as part of the Contract and has been approved by Fisheries and Oceans Canada and British Columbia Ministry of Environment.

165.10.01 Fish Passage and Fish Salvage - Unless the Contractor has written approval from the Ministry Representative and the Environmental Agencies, any instream works in fish bearing streams shall provide for fish passage. It is the Contractor's responsibility to contact the Environmental Agencies to determine fish passage requirements for the specific location.

The Contractor and the Environmental Monitor shall be responsible for fish salvage operations, including the timely acquisition of fish collection permits from Fisheries and Oceans Canada and the British Columbia Ministry of Environment.

165.10.02 Management of Water Discharges - During preparation of stream diversions, culvert installations and other operations involving dewatering where drainage could readily reach a Designated Watercourse, all effluent and silt-laden water shall be discharged to a sediment control pond or a vegetated area acceptable to the Ministry Representative and the Environmental Monitor for removal of silt prior to its release into that Watercourse. This requirement also applies to the control of discharge resulting from curing areas of recent concrete pours for bridges or drainage structure headwalls. The direct discharge or discharge via seepage of untreated, silt-laden water or other deleterious substance into any Watercourse is prohibited.

165.10.03 Encroachment of Fill into Watercourses - Embankments which encroach on the Wetted Perimeter of fish-bearing Watercourses shall either be isolated and dewatered, by means of a cofferdam, until surfaced with riprap, or constructed of clean granular material and riprap

or shot rock which is free of fine-grained material or other potential contaminants. Riprap composition and placement may be further detailed in the Special Provisions. The method of placement of this material shall be such that disturbance and/or alteration of aquatic habitats is absolutely minimized. Fill material must be entirely contained within the proposed fill cross section.

165.10.04 Temporary Stream Crossings - Prior to construction, the Contractor shall provide the Ministry Representative with a plan for approval, describing the proposed locations and types of stream crossings, complete with construction procedures and timing of construction. The Contractor shall forward a copy of the approved plan to the Ministry and obtain Environmental Approvals as needed. Temporary stream crossings shall be subject to the same environmental constraints as permanent crossings, and shall be built to pass, at least, the 10 year return period flood for the time of year during which the structure will be in place. Wherever possible, vegetative cover shall be maintained in order to minimize erosion.

Temporary stream crossings that have been constructed during periods of low precipitation (i.e. summer and late winter) shall be completely removed prior to periods of increased precipitation (i.e. fall and spring freshet), unless otherwise approved by the Ministry Representative.

165.10.05 Instream Equipment Operation or Crossings - The entering or crossing of any Watercourse by construction equipment, when not specified in the Special Provisions or Environmental Approvals, shall require the Contractor to receive written approval of the Ministry Representative and to submit applications or notifications to the Environmental Agencies, as needed. The Contractor shall notify the Ministry Representative 48 hours prior to allowing equipment to cross or enter Designated streams. The Environmental Monitor shall be present while equipment enters into and exits from any Designated Watercourse.

Upon completion, the banks shall be restored, stabilized and revegetated to prevent erosion. This work shall be completed to the satisfaction of the Ministry Representative.

165.10.06 Culvert Installations - Unless otherwise approved by the Ministry Representative, culvert installation in Watercourses shall involve an appropriate method of isolating the work site from the stream, such as the diversion of the stream around the culvert site, and the placement of the culvert in the "dry".

Installation of riprap and other protective works shall be carried out at the earliest possible time following culvert installation in order to prevent erosion and siltation.

165.10.07 Culvert Obstructions - Unless the Watercourse is dry, an obstructed culvert shall be cleared by mechanical means. Any variance to using mechanical

means to clear wet obstructed culverts must have the prior approval of the Workers' Compensation Board.

165.10.08 Channel Diversions - Channel diversions shall be performed in accordance with the Special Provisions. If not specified in the Special Provisions, methods shall be approved by the Ministry Representative, and shall comply with the "Standards and Best Practices for Instream Works", "A Users' Guide to Working in and Around Water", and the "Land Development Guidelines".

165.10.09 Bridge Construction - Bridge Endfills shall be constructed implementing fully the applicable subsections of SS 165, and SS 769, Protection and Retention of Vegetation. The Fisheries Sensitive Zone shall not be disturbed until construction of the endfill or crossing structure is ready to proceed. The Contractor may be required to hand fall trees and leave the root systems in place using close-cut no-grub techniques.

165.10.10 Watercourse Clean-up - Final Watercourse clean-up shall consist of, but not be restricted to, the removal of temporary haul roads and temporary crossings, the reshaping of the stream to its original configuration, width and depth, the protection of stream banks, revegetation, and the removal of all construction related material and debris, including any material and debris deposited upstream or downstream of the site as a result of operations, under the direction of the Environmental Monitor and to the satisfaction of the Ministry Representative. All abandoned temporary diversions shall be plugged and stabilized. In the event that erosion has occurred during the course of construction, the Contractor will be required to recontour, stabilize and revegetate the affected area.

165.11 Ditch Maintenance - To reduce the risk of damage to aquatic habitat and sensitive life stages of fish and other aquatic organisms, the Contractor shall ensure that the excavation and maintenance of ditches is conducted in an environmentally sound manner.

Excavation for ditch cleaning of any ditch that contains or directly drains into fish-bearing waters shall be performed only within Timing Windows as detailed in the "Land Development Guidelines, Appendix III", Ministry of Environment reduced risk timing windows documents, or as specified in the Special Provisions.

The Contractor shall consult local Environmental Agencies for the locations of sensitive areas and local Timing Windows prior to commencement of ditch maintenance. Areas identified as Fisheries Sensitive Zones shall be revegetated by the Contractor prior to the close of the timing window.

165.12 Bridge Maintenance - In performing any bridge rehabilitation or maintenance, the Contractor shall follow the procedures specified in the document "Federal Fisheries Guidelines for the Protection of Fish and Fish

Habitat during Bridge Maintenance Operations in British Columbia".

The Contractor shall take measures to ensure absolute minimal loss of paint and abrasive material into Watercourses during bridge cleaning. Mitigation measures may include placement of ground covers, lined nets or tarpaulins to capture falling debris, blast enclosures to encase the section of the bridge to be abrasively blasted, use of vacuum-shrouded power tools, and use of floating booms and barges to trap floating debris. Similar measures shall also be employed to assist in mitigating paint spray drift.

165.13 Servicing and Operation of Equipment

165.13.01 Transport of Materials - The Contractor shall use equipment and containers that are capable of safely transporting petroleum products and/or hazardous materials in compliance with Section 7.33.1 of the Federal "Transport of Dangerous Goods Regulations" for bulk containers, and Sections 7.21 and 7.23 of the same regulations for materials in packages or small containers. These regulations shall apply to both on-road and on-site transport. In addition to compliance with the Federal Transport of Dangerous Goods Regulations, the transportation of fuel trailers, fuel tanks on skids, and non-commercial fuel trucks shall comply with all the requirements of the Motor Vehicle Act and the British Columbia Fire Code.

The Contractor shall take the necessary precautions to prevent the loss of materials during transport on public highways, roads, access roads, and haul routes. Trucks carrying loose materials shall be covered and restraints shall be used to prevent materials from blowing or falling from vehicles. The Contractor shall be responsible for collection and removal of any and all litter deposited by vehicles or equipment along access routes during construction-related activities, including removal of dirt and mud deposited from truck tires on municipal roadways.

165.13.02 Location and Installation of Fuel Storage Facilities - The siting and installation of all fuel storage facilities shall be the responsibility of the Contractor. Fuel storage shall not be located within 30 m of a Watercourse, within a Watercourses flood plain, or where there is a potential for any spilled fuel to enter a Watercourse or groundwater. Fuel storage facilities shall be located on flat or gently sloping ground and shall be dyked to contain at least 125% of the total capacity of the storage containers. Dykes shall be constructed of impermeable material or lined to ensure that petroleum products cannot escape.

All large fuel storage tanks must be locked and secured when not in use. Automatic shut-off nozzles shall be installed on all dispensing units over 250 ℓ capacity. Fuel storage tanks must be drained within one week of

SECTION 165

completion of construction or within one month of a prolonged shutdown period.

All small fuel storage containers, such as 45 gallon (200 litre) drums, used as a fuel cache shall be installed on a stable storage rack, within an impermeable containment device capable of capturing at least 125% of the total capacity of the storage container(s). A cover, such as a tarp, must be placed over the top of the fuel cache to prevent accumulation of precipitation in the containment device. The small fuel storage container(s) shall contain a metal spigot with a padlock placed on the container when not in use.

In the transport, storage and/or dispensing of fuel and other petroleum-based products, the Contractor shall comply with the requirements outlined in the Ministry of Environment, Lands and Parks/Ministry of Forests publication: "Environmental Standards & Guidelines for Fuel Handling, Transportation and Storage" (December, 1995).

The Contractor shall be responsible for all costs associated with clean-up and disposal of any escaped toxic and hazardous substances.

165.13.03 Servicing of Equipment - The fueling, servicing or washing of machines or equipment within the wetted perimeter or riparian zone of Watercourses is prohibited. No equipment refuelling or serviced should be undertaken within 30m of any Watercourse or surface water drainage. On-site fuelling and lubrication of equipment shall also be conducted as far as possible from detention and sediment control facilities. The Ministry Representative may require that servicing be conducted at Designated sites.

Refuse generated during the servicing of equipment (e.g., air and oil filters, hydraulic fluids, petroleum products) shall be collected and disposed of in an environmentally acceptable location and manner. Where possible, the Contractor is encouraged to recycle lubricants and other waste materials generated during the servicing of equipment and machinery, or alternatively dispose of such materials and refuse at nearby recycling depots. The dumping of oil or other deleterious materials on the ground or in any Watercourse is strictly prohibited. The Contractor shall provide a means of catching and retaining drained oil or other deleterious materials and shall properly dispose of these materials in a location approved by the Ministry Representative.

165.13.04 Equipment Operation in Environmentally Sensitive Areas - Construction equipment shall be operated only within the Designated construction site and access roads. Equipment operators shall not be allowed to damage or destroy vegetation or streambanks outside of this area.

The operation of equipment and machinery in a Fisheries Sensitive Zone must be:

PROTECTION OF THE ENVIRONMENT

- a) authorized by the Ministry Representative
- b) kept to an absolute minimum, and
- c) undertaken only during the period(s) specified in the Special Provisions.

When working in any Designated Watercourse, equipment shall be in good working condition free of leaks, use biodegradable hydraulic fluid and shall be steam cleaned of oil, grease and other contaminants deleterious to aquatic species, prior to commencing work. When working in or near any Watercourse, the Contractor shall ensure that all hydraulic systems, fuel systems and lubricating systems are in good repair. Equipment with fuel or fluid leaks shall not be permitted to enter the wetted perimeter of any Watercourse. Equipment developing such leaks shall be removed immediately and repaired.

165.13.05 Pile Driving Operations

As a result of noise and pressure waves generated by pile driving and their potential harmful effect on fish redds and emergent life stages, Fisheries and Oceans Canada may include conditions in Environmental Approvals that require the employment of measures such as scheduling of works during instream Timing Windows, deploying of bubble curtains or other mitigative apparatus, and/or undertaking hydro-acoustic or fish monitoring programs. The Environmental Approvals may stipulate that the pile driving activities must cease if the monitoring programs identify a potential harmful effect on fish. The Contractor shall be responsible for all activities needed to carry out the work in compliance with the Environmental Approvals, Standards and Best Practices.

165.14 Waste Disposal and Toxic/Hazardous Materials

165.14.01 General - All non-toxic or non-hazardous wastes which are not Designated as combustible waste to be burned on-site shall be either recycled or disposed of in an approved sanitary landfill or other specialized area as indicated in the Special Provisions or as directed by the Ministry Representative. Any waste material that is inadvertently dumped in or adjacent to Watercourses or other Designated Environmentally Sensitive Areas shall be removed by the Contractor and disposed of in an approved manner at the Contractor's expense.

The Contractor shall be responsible for the regular collection and disposal of all waste material generated by employees and sub-contractors. The Contractor shall take the necessary precautions to prevent loss of these materials during transport on public highways and roads, and shall be responsible for cleanup of all of these materials and all litter deposited by employees and subcontractors along access routes during construction-related activities, at no expense to the Ministry. Construction debris shall not be allowed to accumulate on the construction site but shall be collected promptly and regularly removed from the site. The Contractor shall ensure that waste materials are placed

and stored in suitable containers. Waste material shall be disposed of at an approved waste disposal site. The Contractor shall be responsible for providing and regularly servicing animal-proof refuse containers and for ensuring that all employees and subcontractors dispose of wastes to keep the Project clear of waste and garbage.

165.14.02 Spill Contingency Plans - Contingency plans for the clean-up of toxic or hazardous spills shall be prepared prior to construction and submitted, together with a list of spill abatement equipment to be stored on the job site, to the Ministry Representative for review. The Ministry Representative may require the Contractor to have on site any additional equipment or materials deemed necessary to deal with a potential spill. The Contractor shall promptly replace any used spill abatement and clean-up materials and maintain a sufficient inventory of materials throughout construction operations. For operations being conducted adjacent to or within the wetted perimeter of a Watercourse or other Environmentally Sensitive Area, the Contractor shall have an approved spill kit ready for use nearby.

The Contractor shall immediately report any spill of any toxic or hazardous material verbally to the Ministry Representative and the Provincial Emergency Program (24 hour phone line: 1-800-663-3456). Written notification of the spill must follow within two weeks of this verbal report. The Contractor shall immediately take the necessary steps to abate the discharge and provide the necessary labour, equipment, materials and absorbents to contain and remove the spill, clean up the affected area, dispose of waste materials at an approved disposal site, and restore the area to the satisfaction of the Environmental Agencies, at the Contractor's expense. Any soil contaminated by spills shall be removed and replaced by comparable substitutes at the expense of the Contractor. Contaminated soil and vegetation removed shall be disposed of in an approved waste disposal site. If the Contractor fails to respond to the Ministry Representative's requirements for cleanup, the Ministry reserves the right to take whatever action is necessary to clean up the spill and deduct incurred costs from any money due or to become due to the Contractor.

The Environmental Monitor shall document any spills observed in the vicinity of the Project that are not the result of Project-related activities, and notify the Environmental Agencies of such incidents.

165.14.03 Contaminated Sites - If an area within or adjacent to the project site has been identified as a possible source of contaminated or hazardous material and the defined contaminated or hazardous material has not been removed prior to the start of the project, the Contractor shall notify the Ministry Representative at least two weeks prior to the time work is scheduled in or adjacent to that area.

In the event that the Contractor locates material on the

project site believed to be contaminated or hazardous, and which has not been previously identified, the Contractor shall immediately cease work in that area and notify the Ministry Representative. The Ministry Representative will seek investigation and disposal recommendations from regional staff of the British Columbia Ministry of Environment, Environmental Management office. No work shall proceed in the identified or suspected area until such time as these materials have been removed to the satisfaction of the Ministry Representative, representatives of the British Columbia Ministry of Environment Environmental Protection office, and the British Columbia Workers' Compensation Board. Unless it is specified in the Special Provisions, or agreement is made with the Ministry Representative to carry out such work, the Contractor is not responsible for the removal of contaminated or hazardous materials, which are not the result of the Contractor's actions.

165.14.04 Concrete Wastes - The Contractor shall isolate fresh concrete or cement from any Watercourse for 48 hours after placement. Containers or trucks carrying cement or fresh concrete shall be washed at a site approved by the Ministry Representative. Concrete wastes, including wastewater from batching or cleaning, or cutting cured concrete shall only be disposed of at approved and Designated disposal sites (i.e., location identified with proper signing). All cement-contaminated wastewater from cleaning or mixing is to be considered toxic, and must be prevented from entering any Watercourse for at least 48 hours to allow the water to reach neutral pH. Any cement or concrete-contaminated wastewater shall be tested prior to release into a Watercourse. In the event that such wastewater pH levels are unacceptable in terms of water quality for fish and other aquatic species, the Contractor shall take the necessary measures to contain and treat such wastewater until acceptable pH levels are achieved (i.e., pH levels are the same as the receiving waters).

The Contractor shall securely store on-site and use suitable equipment and materials for the mitigation of concrete spills into or in areas adjacent to Watercourses. For example, cylinders of gaseous carbon dioxide shall be kept on the Project site, which shall be used in the event of concrete or concrete leachate discharges into any Watercourse. During any concrete pour within 15 m of, or in work areas above the wetted perimeter of any Watercourse, the Contractor shall ensure that carbon dioxide cylinders and suitable application devices (e.g., weighted soaker hoses) are available on-site and ready for use in the carbonation of water columns to neutralize any concrete leachate that is inadvertently discharged into the Watercourse. Where concrete leachate is allowed to enter settling ponds, such that pH levels become very high, bubbling with carbon dioxide may not be an effective buffering agent. In such cases, it may be necessary to use other methods, such as acid buffers. The Ministry

SECTION 165

Representative shall be responsible for assisting the Contractor in identifying appropriate mitigation options and monitoring effectiveness of procedures to mitigate unacceptable pH levels.

Aged, broken concrete shall only be used as riprap with the approval of the Ministry Representative and the Environmental Agencies. The Contractor shall remove broken concrete or concrete wastes that have been inadvertently placed in non-approved sites on the Project and dispose of them at an approved waste disposal site.

165.14.05 Petroleum Wastes - Refuse generated during the servicing of equipment shall be removed from the site and disposed of in a location and manner that has been approved by the Ministry Representative. The dumping of oil or other deleterious materials (such as diesel used to wash out dump boxes) on the ground is prohibited. Where facilities are located within a reasonable distance, the Contractor shall dispose of wastes at recycling depots.

Solids, sludges and other pollutants generated as a result of construction or removed during the course of treatment or control of wastewaters shall be disposed of in a manner that prevents their direct or indirect discharge to any Watercourse or groundwaters. Effluent generated by the water scrubber of an asphalt mixing plant must be given retention time in suitably sized, impermeable settling ponds prior to release into an adjacent Watercourse. The required retention time will be determined by the Ministry Representative in consultation with representatives from British Columbia Environment.

Asphalt pavement shall be stockpiled for recycling in a specified location, or disposed of in a location approved by the British Columbia Ministry of Environment, as directed by the Ministry Representative.

165.15 Pesticides - The use of all pesticides is subject to pre-approval by the Ministry Representative. The use of herbicides for vegetation control, other than noxious weeds, is not permitted. The Contractor shall comply with all Federal, Provincial and local regulations relative to the storage, use, and proper disposal of pesticides. Relevant legislation includes the Federal Pest Control Products Act and the British Columbia Pesticide Control Act. All pesticide wastes, washwaters, solvents, and containers shall be disposed of in compliance with the British Columbia Environmental Management Act, Special Waste Regulation.

165.16 Air and Noise Pollution

165.16.01 Noise and Emissions - All activities, equipment, processes and work operated or performed by the Contractor in accomplishing the specified construction shall be in strict accordance with Federal, Provincial and local regulations governing noise levels and air emission standards. The Ministry Representative may require the Contractor to have maintenance performed on equipment or alter practices which are judged to produce excessive

PROTECTION OF THE ENVIRONMENT

noise or emissions.

165.16.02 Dust Control - Application and handling of the any dust palliative, with the exception of water, shall be in compliance with the Ministry standards as given in "Maintenance Guidelines for Dust Palliatives and Gravel Road Stabilization".

Dust control techniques may also be required by the Ministry Representative during other construction operations, including but not limited to demolition, drilling, sand blasting and concrete cutting.

165.17 Use of Water

165.17.01 Authorization for Use - For any source of water not specified in the Special Provisions, the Contractor is required to contact British Columbia Ministry of Environment Water Stewardship Division office before any water is diverted, impounded, pumped or used for any purpose, including dust control, compaction, or operation of a work camp. Authorization in the form of an approval for short term use of water may be required to be obtained through an application to FrontCounter BC. The Contractor should be aware that, if required, a water application approval may take at least six weeks to process.

Downstream water flow must be maintained at all times during water takings in fish-bearing waters.

Prior to commencing any work which may affect potable water supplies downstream of the construction area, the Contractor shall ensure that all owners of licensed water intakes have been notified.

Water sources must be approved by the Ministry Representative. In order to reduce the impact on local water supplies and Watercourses, the Contractor may be required to use uncontaminated wastewater, such as that pumped from the surface of sedimentation basins.

165.17.02 Screened Intake Requirements - The intakes of all pumps or diversions used to withdraw water from fish-bearing Watercourses shall be screened in accordance with the Fisheries and Oceans Canada "Freshwater Intake End-of-Pipe Fish Screen Guideline".

The Contractor shall provide and maintain stable access routes to all water withdrawal sites. The location of all such routes shall be subject to the approval of the Ministry Representative and the Environmental Agencies.

165.18 Support Facilities

165.18.01 Location and Operation of Support Facilities - The preservation of trees, shrubs, ground cover, fish and wildlife must be considered in site selection and construction of all temporary support facilities. During site preparation, vegetation shall be removed using selective hand clearing (close-cut with no grubbing) in preference to blanket clearing with heavy machinery, retaining vegetative cover wherever possible.

SECTION 165

The Contractor shall locate temporary field offices, storage, plant and other facilities on pre-existing cleared portions of the job-site or on areas to be cleared during the course of routine construction unless otherwise authorized by the Ministry Representative.

Where possible, for aesthetic purposes, work camps and parking areas shall be located behind a vegetative screen buffer. The Ministry Representative may require that work vehicles and heavy equipment shall be parked in Designated locations only.

The Contractor shall abide by all pollution control practices, laws, ordinances and regulations applicable to the construction of work camps and support facilities. The Contractor shall obtain the approval of the British Columbia Ministry of Health, the British Columbia Ministry of Environment Environmental Management offices, and any applicable local authority prior to the installation and/or operation of sewage disposal and potable water distribution systems.

Work camps, field office facilities and work sites shall be kept clear of litter and garbage. The Contractor shall be responsible for providing and regularly servicing animal-proof refuse containers and for instructing all employees to dispose of food wastes accordingly. Sanitary landfill operations shall be located well away from the main camp in order to minimize conflicts with wildlife.

Solid wastes shall be recycled or disposed at an approved landfill facility where possible. Burning of combustible solid wastes shall be subject to all applicable emission guidelines. Solid waste containers shall be large enough to contain all of the wastes generated between collection periods. The containers shall be constructed such that spilled liquids are contained and access by insects and wildlife is prevented. Storage areas and containers shall be maintained in a sanitary condition and shall be covered to prevent spreading of wastes by water, wind or animals. Transportation of solid waste shall be performed in a manner which prevents littering during transit to the disposal site.

Sanitary landfill sites shall be located a minimum of 450 m from Watercourses or campsites, and shall be situated such that contamination of any stream, lake or groundwater system is avoided. The location of all sanitary landfill sites must be approved by British Columbia Ministry of Environment, Municipal or local officials and the Ministry Representative. The bottom of the landfill site shall be located at least 2 m above the water table. Trees and other vegetation shall be removed progressively as the size of the landfill increases in order to minimize erosion by wind and water.

Sanitary wastes shall not be discharged into Watercourses or on the soil surface. All temporary toilets shall be equipped with approved septic tanks having safe drainage or with closed holding tanks which are emptied only into

PROTECTION OF THE ENVIRONMENT

approved treatment plants or sewage tanker trucks. All temporary toilets used on -site shall be placed in environmentally acceptable areas, and shall be secured to avoid or minimize damage from vandalism.

165.18.02 Abandonment of Sites - Upon completion of construction, all temporary support facilities and camp infrastructure, including buildings, equipment, lumber, refuse, surplus materials, fencing and other such items shall be removed. The original drainage pattern shall be re-established, and all disturbed areas shall be revegetated.

The Contractor shall ensure that all project-related sites are left in an environmentally acceptable manner, subject to the approval of the Ministry Representative and the Environmental Agencies. Decommissioned construction areas, material sources and access roads shall be reclaimed by the Contractor such that as much of the original forest, wildlife, agricultural productivity, recreational use, etc. as possible is restored or enhanced.

165.19 Protection of Livestock and Wildlife

165.19.01 Protection of Livestock and Wildlife - Harassment of livestock or wildlife in and adjacent to the project site is prohibited. The presence of livestock or wildlife in or adjacent to the project site, field office trailers or construction camp shall not be encouraged by feeding. The Contractor is required to inform work crews of the location of wildlife and livestock crossing sites situated within the boundaries of the construction area.

If it is necessary to arrange the removal or transfer of beavers, bears or other wildlife from the work-site or camp the Contractor shall contact a British Columbia Ministry of Environment Fish and Wildlife representative prior to taking action, and follow the course of action recommended.

165.19.02 Disturbance of Fish and Wildlife - Rules regarding hunting, fishing and the discharge of firearms by the Contractor, employees and sub-contractors, within the project area during the period of construction, shall be made in consultation with the Ministry Representative and the local British Columbia Ministry of Environment Fish and Wildlife office. The Contractor shall be responsible for ensuring compliance with these rules.

165.20 Archaeological and Paleontological Discoveries

- In the event that any item of archaeological, heritage, historical, cultural or scientific interest is found on the project site, such item(s) shall remain the property of the Province and the Contractor shall, on making or being advised of such a find, immediately cease operations in the affected area, minimize activities which create ground disturbance in and adjacent to the affected area, and notify the Ministry Representative of the discovery. The Ministry Representative will notify the Archaeology Branch of the British Columbia Ministry of Tourism, Sport and the Arts. Work shall not resume within 30 m of the discovery site until an appropriate directive has been

SECTION 165

received from that agency.

To protect archaeological and paleontological sites that are situated within or adjacent to a project site, the Contractor may be required to use a variety of mitigative measures, including but not limited to drainage or erosion control, slope stabilization measures, or erecting fences or other suitable barriers to protect archaeological or paleontological sites that are situated within or adjacent to a project site. These measures, with any negotiated extensions of time for completion of the contract they require, will be determined and adopted at the discretion of the Ministry Representative. The costs associated with such mitigative measures will be borne by the Ministry, unless otherwise specified in the Special Provisions.

A buffer zone, in which no land alteration or other activity is permitted, may be required to ensure adequate site

PROTECTION OF THE ENVIRONMENT

protection. The width of this buffer zone shall be determined by the Ministry Representative in consultation with a representative of the Archaeology Branch of the British Columbia Ministry of Tourism, Sport and the Arts. The Contractor shall be responsible for the actions of employees and sub-contractors with respect to site vandalism and the unlicensed collection of artifacts from Designated archaeological sites in and around the construction area.

165.21 Resolution of Disputes - In the event that a dispute arises between the Contractor and the Ministry, or the Environmental Monitor and the Ministry regarding environmental matters related to the project, the Ministry, or where appropriate, the Environmental Agencies, will have the final decision.

SECTION 194

TRAFFIC MANAGEMENT FOR WORK ZONES

PART A – GENERAL

194.01 General – Traffic management requirements will be as specified herein and as specified in the Special Provisions or by the Ministry Representative.

The Contractor's Traffic Management Plan, Construction Schedule and its provisions for traffic control and safety will be based on providing safe passage through the Work Zone for all road users (i.e. cyclists, pedestrians and motorists). The Contractor will at all times make provisions for traffic through the Site to a sufficiently high standard to ensure the safety of the workers on the Project, the safety and the convenience of the travelling public, driver expectancy, and the protection of the Work Area. The Contractor will supply and maintain all traffic control devices and personnel necessary to provide all traffic control.

The Contractor's accommodation for pedestrian and vehicular traffic, and proposed traffic control procedures, for each work operation, will require approval by the Ministry Representative prior to the start of that operation.

Any one or more of the advance warning area, transition area, buffer zone and termination area of the traffic control (work) zone may be outside the Limits of Construction, but this will in no way diminish the Contractor's responsibility to meet the requirements of the Traffic Management Plan.

194.02 Definitions – For purposes of this Section, the following general terms are defined in the Traffic Management Guidelines for Work on Roadways:

- Traffic Management Plan
- Traffic Management Strategy
- Traffic Control Plan
- Incident Management Plan
- Public Information Plan
- Implementation Plan

In addition, the following terms are used in this Section and defined below:

“Work Area” refers to an area that contains the work activity and is closed to traffic and set aside for the exclusive occupation by workers, equipment and construction materials. Work areas may remain fixed in location or may move as work progresses.

“Work Zone” as defined in the Traffic Control Manual for Work on Roadways.

“Construction speed zone” as defined in the Traffic Control Manual for Work on Roadways.

194.03 Standard Documents – Traffic Management Plans shall be developed in accordance with standards defined in the latest version of the following documents:

- MoT Traffic Management Guidelines for Work on Roadways (TMG)
- MoT Traffic Control Manual for Work on Roadways (TCM)
- MoT Electrical and Traffic Engineering Manual and all current Technical Bulletins
- TAC Geometric Design Guide of Canadian Roads
- MoT Supplement to TAC Geometric Guide
- Workers' Compensation Board (WCB) Regulation

All Ministry Publications listed above can be purchased from:

GOVERNMENT PUBLICATION SERVICES
MINISTRY OF MANAGEMENT SERVICES
PO BOX 9452 STN PROV GOVT

VICTORIA BC V8W 9V7

www.Publications.gov.bc.ca

Email: QPPublications@gov.bc.ca

PHONE: 1-800-663-6105

FAX: (250) 387-1120

194.04 Traffic Control Supervisor – The Contractor will designate a traffic control supervisor who has the Contractor's authority to respond to traffic control requirements and who will provide surveillance of traffic conditions through the Work Zone. This person or qualified designate will be available at all times, both when the Contractor is working and during weekends or other periods when the Contractor's forces are not active on the Project, to respond to calls from the police and from representatives of the Ministry concerning damage or deficiencies in the traffic control devices and the passage for traffic through the Work Zone.

The traffic control supervisor shall meet the requirements of the TMG and WCB Regulation and shall not be the Contractor's site superintendent.

194.05 Compliance with Acts and Regulations – The Contractor shall comply with the requirements of any legislation, Regulations and by-laws as are in force for the regulation of traffic or use of any road upon or over which it is necessary to carry out work or to haul materials or things.

SECTION 194

PART B – PLANNING AND SCHEDULING

194.11 Provide Traffic Management Plan – The Contractor shall prepare a Traffic Management Plan (TMP) in accordance with the Ministry definitions and guidelines specified in the Traffic Management Guidelines for Work on Roadways Manual.

The Special Provisions or the Ministry Representative will specify the Traffic Management Strategy and required documentation for the Traffic Management Plan.

The Traffic Management Plan will be fully integrated with the Contractor's plan and schedule for carrying out the work, comply with the requirements of the TCM, the Traffic Management Guidelines for Work on Roadways, the Traffic Management Strategies listed below, and with the provisions of the Contract.

194.12 Traffic Management Plan Review – The Ministry Representative may review the Contractor's Traffic Management Plan for general conformance with the requirements of the Special Provisions and the Contract for sufficiency of detail to provide a complete and unambiguous traffic control layout. No review or change requested by the Ministry Representative in any way relieves the Contractor of any if its responsibilities for ensuring safe and adequate traffic management. No work that effects traffic will be permitted until the Ministry Representative accepts the Traffic Management Plan.

Where the Traffic Control Manual shows a choice of traffic control layouts for a given specific situation, the Ministry Representative may request the Contractor to use an alternative layout which is acceptable.

The following time periods are required for plan review and acceptance unless otherwise specified in the Special Provisions or by the Ministry Representative:

- A Traffic Control Plan shall be submitted to the Ministry Representative for review at least fifteen (15) working days prior to the start of any Works effecting traffic flows. The following conditions shall apply:
 - Any plan modifications shall be submitted to the Ministry Representative for review at least ten (10) working days prior to any changes being made in the field.
 - A staged plan shall be submitted to the Ministry Representative for review at least ten (10) working days prior to implementation of a new stage.
- The Implementation Plan, if required, shall be submitted to the Ministry Representative for review at least fifteen (15) working days prior to the start of any Works effecting traffic flows.
- The Public Information Plan, if required, shall be submitted to the Ministry Representative for review

TRAFFIC MANAGEMENT FOR WORK ZONES

at least fifteen (15) working days prior to the start of any Works effecting traffic flows.

- The Incident Management Plan, if required, shall be submitted to the Ministry Representative for review at least fifteen (15) working days prior to the start of any Works effecting traffic flows.

PART C – TRAFFIC MANGEMENT OPERATIONAL DETAILS

194.21 Speed Zones – Reduction in speed limits may take several forms as defined in the TCM 1.4.6. Construction speed zones within the Project will be determined at the discretion of the Road Authority or as specified in the Special Provisions.

The Contractor's work plan, Construction Schedule and its provisions for traffic control and safety will include references to the reduced posted speeds referred to in Subsection 194.21.

The location and length of posted speed reduction zones shall be adjusted daily, or more frequently as appropriate to the Work, to provide the shortest reduced speed zone practical. For example, on a resurfacing project, the reduced speed limit would usually be invoked around active operations such as milling, priming, paving, and, if necessary, at access points to pits and the plant, but will not generally be acceptable for areas of the Site used only for haul.

194.22 Use of Channelling Devices and Taper Rates – Traffic cones, temporary highway delineators, standard barricades or other marker devices such as wooden or metal saw horses, temporary marking tape, etc., shall be used in the following circumstances for channelling traffic:

- a) from one lane to another or for merging traffic where a reduction in the number of lanes must be effected
- b) around a hazard on the travelled way
- c) through an area of unfinished construction where the intended traffic lanes are not self-evident
- d) at any other location where, in the Ministry Representative's opinion, channelling will ensure the safe passage of public traffic.

Minimum taper rates and spacing between cones or delineators shall be as shown in TCM.

194.23 Equipment on the Travelled Way – When working on the travelled way equipment shall be placed in such a position as to present a minimum of interference and hazard to the travelling public. Equipment units shall be kept as close together as working conditions will permit and preferably on the same side of the travelled way. Equipment shall not be left overnight on the travelled way but shall be located so as to avoid the possibility of an accident.

SECTION 194

194.24 Roadway Configuration – The Contractor shall arrange to keep interconnected lanes of the highway open to traffic at all times with the least amount of inconvenience to the travelling public unless otherwise authorized by the Ministry Representative.

194.25 Roadway Condition – The Contractor shall keep the travelled way well-graded, free of potholes and of sufficient width that the required number of lanes of traffic may pass. The subgrade shall be completed progressively in order that gravel surfacing may follow in an orderly manner. Prior to tearing up a portion of the existing travelled way the Contractor shall obtain Ministry Representative approval and shall also have available a sufficient supply of crushed gravel, or another approved product, to ensure a smooth riding surface during the work.

194.26 Closures – Road closures shall not be permitted until the Contractor requests and receives written permission from the appropriate authority in the Ministry of Transportation. This request shall be submitted in writing not less than fifteen (15) days in advance of the closure.

Upon receiving written permission for the closure, the Contractor must notify the local police, fire, ambulance, municipality, school board, and public transit at least seven (7) days in advance of the closure.

The public must be notified by local radio and newspaper at least (5) days in advance of the closure. The Contractor shall arrange any public announcement relating to the Contract and incorporating the Ministry logo through the Ministry Representative and Corporate Writing Services. Such advertisements will be made at the Ministry's expense. Notices or other advertisements of the Contractor unrelated to the Contract or where the Ministry's logo or name is not incorporated may be made by the Contractor at the Contractor's expense.

All costs related to the above shall be borne by the Contractor.

194.27 Detours – Where detours are required for the execution of the work or deemed necessary by the Ministry Representative, the Contractor shall provide well graded, gravelled detours or temporary roads to facilitate the passage of traffic around the restricted construction area. The Contractor shall be responsible for signs, maintenance of same and maintenance of the detour or temporary road. The Contractor shall consider the condition of the pavement used for detours and its impact on the safety and function of the detour. Milled surfaces upon which traffic is to run shall be clean and allow adequate drainage.

The minimum design requirements for any detours will be specified in the Special Provisions or by the Ministry Representative.

TRAFFIC MANAGEMENT FOR WORK ZONES

Where the anticipated detour extends beyond the existing road surface, the Contractor will submit an engineering design to the Ministry Representative for review, a minimum of fourteen (14) days in advance of building the detour. The engineering design will include the design speed, the horizontal and vertical geometry, plus evidence that the design vehicle is accommodated for all movements and that all the requirements of this Contract are satisfied.

Where the anticipated deviation is minor, the Contractor may apply to the Ministry Representative, in writing, for approval to proceed without a formal design. Such approval does not relieve the Contractor of any of its responsibilities for provision of a safe site.

194.28 Access to Property – During operations the Contractor shall provide and maintain reasonable road access and egress to property fronting along or in the vicinity of the work unless other reasonable means of road access exists. The Ministry Representative will be the sole judge of what may be deemed reasonable road access.

194.29 Winter Lay-Up – In the event that the Work is stopped due to winter conditions, the Site is to be left in a condition as specified in the Special Provisions or as deemed acceptable by the Ministry Representative.

194.30 Delays – All major and minor delays to the travelling public will be determined by the Ministry Representative.

The Contractor will monitor the queue lengths created by any delay to the flow of traffic. Traffic must be cleared prior to starting another delay unless authorized by the Ministry Representative. If the Ministry Representative determines that the traffic delays are excessive, the Contractor shall immediately cease construction activities and make all the travel lanes available to traffic as quickly as possible. Resumption of roadway operations shall be permitted as traffic levels dictate and upon approval by the Ministry Representative.

PART D – TRAFFIC CONTROL DEVICES

194.41 Traffic Signals – Short one-way sections, such as bridge and culvert construction detours, etc., may be controlled by traffic signals and it is acceptable where the restriction will be in effect for an extended period. The use of signals on long one-way zones is not recommended as delays to traffic may be of considerable length and might not be accepted by the motorist.

Where traffic signals are requested by the Contractor, the Contractor shall arrange to have a qualified Traffic Engineering consultant prepare a Traffic Engineering study for the signal. The study shall document the following:

- Site layout
- Anticipated volumes
- Requirements for advance warning signs

SECTION 194

- Actuation
- Proposed traffic signal timing plans

The Contractor will submit the study to the Ministry Representative for review. The approval for the installation of the signals will be determined by the Ministry Representative.

If the proposed traffic signal installation is approved by the Ministry Representative, the Contractor shall:

- Prepare a traffic signal design, signed and sealed by an electrical engineer registered with the APEGBC
- Supply and install all traffic controller equipment
- Supply power
- Operate and maintain the signals

Changes to the signal timing plans shall only be prepared by a qualified professional traffic engineer experienced in traffic signal timings. Traffic controller technology used shall comply with industry standard practice and shall have a conflict monitoring mechanism that will ensure signal malfunctions/conflicts result in the signal going to a flashing red state. Signals shall be vehicle actuated unless otherwise approved by the Ministry Representative. Signal operations shall conform to TCM 2.2.8 and the *Electrical & Traffic Engineering Manual*.

Where the work activity impacts the operation of an existing signal, the Contractor must submit a written notification to the Ministry Representative a minimum of ten (10) days in advance of the disruption to the signal.

194.42 Pilot Cars – The use of pilot cars may be warranted where public traffic must use a particularly hazardous route, or where traffic is required to remain in one lane, or change periodically from one lane to another, or negotiate a section of construction at restricted speed. Pilot cars shall be operated in conjunction with flagpersons stationed at each end of the restricted section. When required, the Contractor shall provide sufficient pilot cars, as may be required from time to time, to keep a steady and controlled flow of traffic moving around or through the construction area.

Pilot cars shall be equipped with the following:

- a) A sign or signs with minimum 200 mm letters, designating the vehicle as a pilot car, and showing the message in both directions. Signs shall be illuminated during the hours when headlights must be used. Signs shall not be displayed when the vehicle is not being used for piloting.
- b) Amber flashing lights mounted on the roof at either side so as to be clearly visible from both directions. The flashing lights shall be in use for both day and night piloting.

194.43 Use of Flagpersons – It is generally expected that flagpersons will be required in the following situations:

TRAFFIC MANAGEMENT FOR WORK ZONES

a) when public traffic is required to pass working vehicles or equipment which may block all or part of the travelled roadway.

b) when it is necessary to institute a one-way traffic system through a construction area or other blockage where traffic volumes are heavy, approach speeds are high, and a traffic signal system is not in use.

c) in high speed, high volume areas where temporary protection is required while other traffic control devices (barricades, cones, signs, etc.) are being erected or taken down.

d) for emergency protection when other traffic control devices are not readily available.

e) in all situations, where adequate protection for workers, working equipment and public traffic is not provided by other traffic control devices.

194.44 Traffic Signs – All standard signs, new and replacement, shall meet current Ministry specifications. The Ministry *Specifications for Standard Highway Sign Materials, Fabrication and Supply* are located on our Ministry web page at:

http://www.th.gov.bc.ca/publications/eng_publications/signs/Sign_Fabrication_Specs.pdf

Prior to the commencement of work the Contractor shall supply all posts, hardware and equipment required for the proper installation and maintenance of the project (C-35) signs and the Contractor's own "Construction Ahead" (C-18) signs. The Contractor shall place the signs as indicated in the TCM or as directed by the Ministry Representative.

Upon completion of the project the Contractor shall remove the C-35 signs and the C-18 signs, posts and hardware when directed by the Ministry Representative. The removal of the signs shall also include the backfilling, compacting and dressing of the postholes to the satisfaction of the Ministry Representative.

The signs shall be erected in advance of all highway and bridge construction projects whether undertaken by contract or day labour. The signs may be omitted at the direction of the Ministry Representative if the project is not in public view.

The Contractor shall supply and maintain all necessary signs and traffic control devices required by this specification and the TCM or as ordered by the Ministry Representative. All signs and devices used must conform to the standards detailed in this manual.

194.45 Barricades, Lights, Delineators, Traffic Lines – The Contractor shall provide, erect and maintain all types of temporary marker devices including traffic line marking tape, barricades, fences, delineators, flare-pots, battery operated amber flashing lights and 110 volt steady burning or simultaneous flashing lights, in order to ensure safety to

SECTION 194

the workers and the general public. These devices shall be as required by the Special Provisions and the TCM, or as directed by the Ministry Representative.

Flashing amber lights, if deemed necessary by the Ministry Representative, are used for extra night time effectiveness and the batteries of the flashing lights shall be checked each day.

Battery operated flashing lights, if two-faced, and if used to mark the right hand edge of a travelled lane, must have one face covered so that the light is not visible to traffic travelling in the other direction. Flashing lights having two faces showing in opposite directions may be used only if it is necessary that the obstruction or lane edge being marked be seen from both directions of travel. They should not be used in a line of delineators through an area of incomplete construction except where traffic must be diverted and a specific hazard exists.

Temporary road construction lighting installations shall be positioned as shown in FIGURE 1: Positioning of Temporary Lighting Adjacent to a Highway to minimize glare and resulting impaired driver vision. Lights shall be aimed away from any approaching traffic and at an angle of less than 45 degrees above vertical. Where lights cannot be located as shown then temporary glare screens shall be used to shield the traffic from the light source. These glare screens shall be metal or an opaque plastic material designed to shield the lighting from the eyes of the driver.

The Contractor shall be responsible for the application and removal of all temporary pavement marking and reflective devices. When traffic lanes have to be redefined for Long Duration Work, the Contractor shall eradicate all redundant temporary or pavement markings that are not required for the intended traffic patterns.

TRAFFIC MANAGEMENT FOR WORK ZONES

Class I and Class II standard barricades are illustrated in the TCM. Temporary delineator posts shall be as shown on Drawing SP194.02. In speed zones of 50 km/h or less, the minimum height of traffic cones shall be 450 mm. Where the maximum speed limit is over 50 km/h, the minimum height of cones shall be 700 mm.

194.46 Changeable Message Signs –The use of changeable message signs (CMS) may be specified in the Special Provisions or by the Ministry Representative. Each sign must be portable. When in operation, the CMS shall be a minimum of two (2) metres from the bottom of the sign display to the road surface, and shall be level and capable of pivoting for sighting purposes. The specifications of the sign are as follows:

Sign unit:	Yellow/Orange LED display
Sign display:	3 lines with 8 characters per line
Character size:	450mm (18 inches)
Character matrix:	5 x 7
Remote dial-up access:	By cellular phone or equivalent

A full matrix sign may be used given that it has the display parameters noted above.

The Contractor is responsible for the CMS including but not limited to bringing the signs to the Project, moving and setting-up, providing storage as required including moving the signs into and out of storage, maintaining the signs in full operating condition, ensuring the correct message is being displayed, damage to or loss of the signs and returning the signs to the supplier. The Contractor shall provide to the Ministry Representative with a description of the messages displayed and the procedures of how the messages on the CMS will be changed when the Contractor is on and off site.

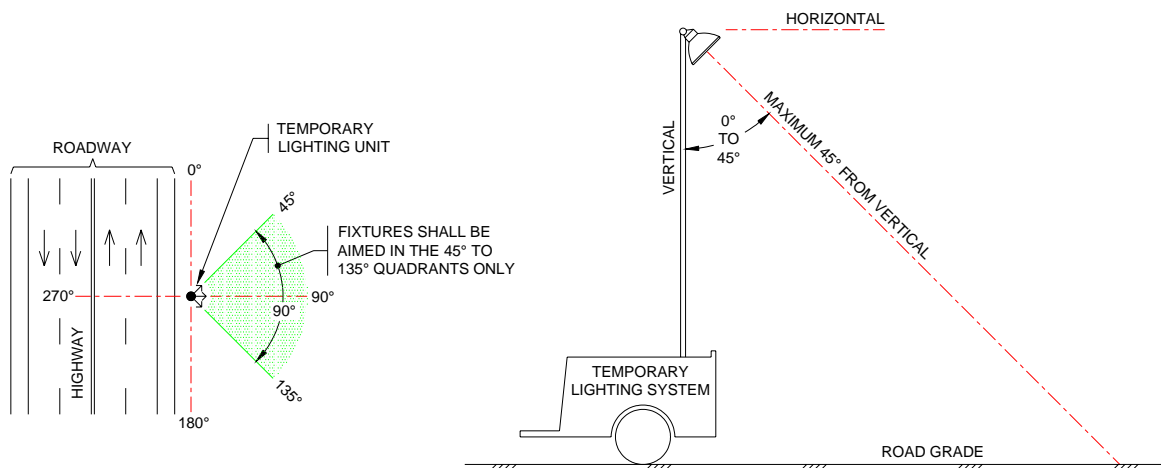

FIGURE 1: Positioning of Temporary Lighting Adjacent to a Highway

PART E – GENERAL MAINTENANCE

194.51 Maintenance – The Contractor shall be responsible for the continuing maintenance of all traffic control devices in use as follows:

- a) Signs, etc., not applying to existing conditions shall be removed or covered. If covered, such as after sundown or during periods when work is suspended, the covering shall be placed over the sign so as to totally obliterate the message thereon. Where operations are carried out in stages, only those devices or signs, which apply to the current stage, are to be left in place or uncovered.
- b) Signs shall be checked daily for legibility, damage, suitability and location. Dirty, damaged, unsuitable or misplaced signs shall be cleaned repaired or replaced. Signs and delineators with a reflective surface shall be cleaned as frequently as necessary to ensure full reflectivity. As considerable damage may be inflicted on signs and devices during a weekend, the Contractor shall conduct a check for replacement or repairs before the rush hour on Monday morning. Similarly, high traffic volume and recreational routes shall be checked during the weekend or at any other time that works is not in progress.

During hours when headlights are required, signs that have not been treated with a reflective coating shall be

illuminated. After sundown all signs shall be checked for visibility and those that cannot be seen clearly shall be adjusted or replaced.

PART F – PAYMENT

194.61 Payment – The cost of all Traffic Management requirements, including the provision of pilot cars, all flagging and traffic control equipment, and personnel covered in this Section and the Contract Documents, or as ordered by the Ministry Representative, will be considered to be included in the unit prices bid for the applicable work of the Contract unless otherwise specified in the Special Provisions.

However, where pilot cars and flagpersons are included as bid items in the Contract Documents, a record of the days and hours that each pilot car and/or flagperson was employed shall be submitted daily by the Contractor for verification and approval of the Ministry Representative. In such event the overtime “hours worked” by flagpersons in accordance with the current union shall be expressed in equivalent straight-time “hours earned” for payment at the rate bid. Pilot cars will be paid for at the all found rate bid in the Schedule for the actual number of hours operated as such.

SECTION 200

CLEARING AND GRUBBING

200.01 Clearing – Except for trees and shrubs to be preserved as indicated on the Drawings or designated by the Ministry Representative, "Clearing" shall mean the complete removal and disposal of all standing and fallen trees, stumps, logs, upturned roots, rotten wood and all other vegetation growth, and accumulations of rubbish of whatsoever nature, and any other objectionable material from the area shown on the Drawings, or as directed by the Ministry Representative. Protective measures for the protection and retention of vegetation are specified in SS 69.

It shall also include the removal of existing cribwork, guard rail, fences, siphon structures built of timber and/or metal, culvert pipes of all types and timber box culverts within the limits of the work; but shall not include the removal of concrete buildings or their foundations, concrete bridge piers or abutments and their footings, concrete siphon boxes or concrete box culverts. The above items, which are excluded from Clearing shall be classified as Solid Rock and will be paid for as such in accordance with the measurements established by the Ministry Representative, and at the unit price bid in the Schedule of Approximate Quantities, and Unit Prices for Solid Rock.

The area to be cleared shall include those areas required for the highway right-of-way, Ministry provided borrow pits, and quarry sites, Ministry or Crown gravel pits and access roads thereto, if ordered by the Ministry Representative; off-take ditches or other drainage ditches and channels for stream diversions either within or without the right-of-way; clearing of debris in streams as indicated on the Drawings, or as directed by the Ministry Representative within the Site; foundations for structures and the right-of-way as shown on the Drawings, or as directed by the Ministry Representative, for intersecting public and private road approaches or diversions of same outside the main highway right-of-way. All such areas are hereinafter referred to as the "Area."

200.02 Disposal of Material – All material, slash and debris resulting from clearing operations shall be disposed of by burning unless there are specific provisions for otherwise disposing of same. Unmerchantable timber, stumps, etc., shall not be disposed of by pushing outside the clearing and grubbing right-of-way. All trees shall be felled within the Area but, in the event of any trees falling outside the Area, such trees shall be cut up and together with all debris and slash therefrom, brought back to the Area and there burned. The Ministry Representative may designate certain trees or shrubbery to be left

standing, in which case the Contractor shall take every precaution not to damage or injure such trees or shrubbery in felling adjacent timber, burning or any other clearing operations as specified in SS 769.

Such trees or shrubbery are to be limbed or thinned to such height and extent as may be directed by the Ministry Representative. No deduction will be made in the total quantity of clearing for any trees or shrubbery ordered to be left standing; no additional payment will be made for any limbing or thinning of such trees or shrubbery as may be directed by the Ministry Representative.

Except as hereinafter provided, all slash and debris shall be piled and burned at points located centrally in the Area. The number of fires to be started at any one time shall be limited to the capacity of the Contractor's equipment and organization to provide adequate protection against the spreading of the fires to adjacent timber or property.

All burning shall be carried out subject to the Provisions of the Forest Act and regulations thereto. In the event of Forestry regulations prohibiting burning, the slash, debris, etc., may be piled along the sides of the Area until such time as the regulations are rescinded.

Clearing must be carried on and completed at least 1 km ahead of grading operations.

200.03 Grubbing – Grubbing means the entire removal and disposal by burning as described in SS 200.01 "Clearing" and SS 200.02 "Disposal of Material" of all stumps, roots and embedded logs to a depth of 0.6 m below the ground line.

Grubbing shall be carried out over the entire Area as defined in SS 200.01 "Clearing." Grubbing shall be fully completed at least 300 m in advance of grading operations.

200.04 Danger Trees – This item shall consist of removing, on written order of the Ministry Representative, any leaning or dangerous trees or snag outside the clearing Area.

Such trees shall be felled and disposed of as provided for in SS 200.01 "Clearing" and SS 200.02 "Disposal of Material."

The Contractor will not be required to grub the stumps of any danger trees.

200.05 Payment for Danger Trees – Danger trees will be measured in three sizes according to the diameter of the tree trunk measured at a point 1.25 m above the ground line at the base of the tree.

SECTION 200

CLEARING AND GRUBBING

These sizes shall be as follows:

- a) Under 0.75 m in diameter
- b) Between 0.75 m and 1.5 m in diameter
- c) Over 1.5 m in diameter.

Compensation for removal of danger trees as provided herein shall be made at the following unit prices which shall be accepted as full payment for everything furnished and done to remove danger trees as specified:

- a) Under 0.75 m in diameter – \$25.00 per tree
- b) Between 0.75 m and 1.5 m in diameter – \$60.00 per tree
- c) Over 1.5 m in diameter – \$100.00 per tree.

200.06 Mail Boxes – Where it becomes necessary to remove or otherwise disturb existing mail boxes within the limits of any project, the Contractor will be required to install the boxes temporarily in such a position that their usefulness will not be impaired. After construction work has been completed, the boxes shall be re-installed at positions designated by the Ministry Representative. No new posts or materials will be required, except that any damage caused by the Contractor to either boxes or supports, due to the Contractor's negligence, shall be repaired by the Contractor at the Contractor's expense.

All costs in connection with the removal and replacement of the mail boxes, as specified above, shall be considered as incidental to the construction of any

improvement and shall be included in the unit prices for the various pay items of work involved in the contract. No additional compensation will be made.

200.07 Removal of Existing Signs and Symbols –

When construction operations are started, the Contractor shall remove all existing Signs and Symbols of the Ministry not needed for the safe and orderly direction of traffic, and any other authorized signs within the limits of the right-of-way, and shall deliver them to such point as directed by the Ministry Representative.

Payment for this work shall be included in the unit prices for the various pay items of work involved in the contract. No additional compensation will be paid.

200.08 Quantities and Payment –

Clearing will be paid for at the unit price bid per hectare of clearing and will, unless otherwise specified, comprise the full length and breadth of the right-of-way as shown on the Drawings or as directed by the Ministry Representative. Grubbing will be paid for at the unit price bid per hectare of grubbing and will, unless otherwise specified, comprise the full length and breadth of the right-of-way as shown on the Drawings or as directed by the Ministry Representative.

These prices shall be accepted as full compensation for everything furnished and done in connection therewith, regardless of the nature or condition of the Area.

SECTION 201

ROADWAY AND DRAINAGE EXCAVATION

DESCRIPTION

201.01 General – Roadway and Drainage Excavation shall include all excavation and the construction of all embankments required for the formation of the roadbed, parking areas and look-outs; excavation for any drainage ditch, off-take ditch or channel for stream diversion within or outside the right-of-way; removal of surcharge material, topsoil and organic waste material from the roadway, and of topsoil and unsuitable overburden from any Ministry provided borrow pit or any Ministry or Crown gravel pit, and disposal of same, as may be directed by the Ministry Representative; excavation of materials below grade; excavation of borrow pits; the grading necessary to construct any frontage road, gravel pit access road, borrow pit access road or any other access road, public or private, either within or outside the right-of-way, only to Ministry provided sources as may be ordered by the Ministry Representative; the grading of connections to intersecting roads, public or private, either within or outside the right-of-way; the hauling and disposal of all excavated material, and the trimming and shaping of all excavations and embankments.

201.02 Extent of Work – The dimensions of the excavations and embankments shall be as shown on the Contract Drawing but the Ministry Representative may increase or decrease the width of the roadbed or the ratio of the slopes.

Construction Grade is defined as the grade upon which the Asphaltic Pavement is laid.

Subgrade is defined as the grade upon which the first layer of select granular sub-base or base material is laid.

MATERIALS

201.11 Description of Material Types – Excavation shall be classified, as approved by the Ministry Representative, under the following material types:

- a) Type A
- b) Type B
- c) Type C
- d) Type D

The material encountered in any highway excavation shall be classified as one of the four types listed above.

In no case shall a material be classified using percentages of two or more types.

It is possible that material may change at some level in the excavation. Where such a change occurs, in order to obtain approval for a change in classification, the Contractor shall immediately notify the Ministry Representative. If a

classification change is approved, sufficient field measurements will be taken to establish the boundary between the two types of material.

201.11.01 Type A - Solid Rock – Type A shall include all forms of "solid rock in place" occurring in masses, ledges, seams or layers of sufficient hardness to require breaking by continuous drilling and blasting before excavation and removal.

It shall also include detached masses of rock or boulders individually containing a volume of 1.5 m³ or more.

201.11.02 Type B - Materials Containing More Than 50% Loose or Broken Rock – Type B Material shall mean loose or broken rock, boulder gravel, or any other material containing at least 50% boulders or broken rock, having a size greater than 0.03 m³ but less than 1.5 m³ and in a state not requiring loosening, or drilling and blasting for removal.

Any excavation or portion thereof, containing the 50% boulders or broken rock of the size described above, shall be classified as this type of material and will be paid in its entirety under this category.

Any excavation, not containing 50% boulders or broken rock of the size described above, shall be classified in its entirety as Type D Material, and in that event no allowance will be made for the smaller percentage of boulders or broken rock in the material.

201.11.03 Type C - Materials Requiring Ripping – Type C shall include those materials of such density or so firmly cemented together that a force of at least 360 kN per linear metre of ripper shank or ripping equipment embedded in the material is required to loosen the material. If the material can be loosened with a lesser force, then the material will be classified as Type D.

If a means other than ripping equipment is used to loosen materials, the force generated must be equivalent to that specified above.

Where deemed necessary by the Ministry Representative, a ripping test will be conducted using a bulldozer or other appropriate equipment, under suitable weather conditions, that will develop sufficient traction and effectively deliver a force of 360 kN per lineal metre of ripper shank embedded into the alleged Type C. The material will only be classified as Type C if it cannot be loosened under such an applied load.

The test will be conducted at the Contractor's expense unless the test indicates, to the satisfaction of the Ministry Representative, that the material is Type C. In that case, the cost of the equipment (including mobilization if the equipment is brought in solely for the purpose of the test)

SECTION 201

and the operator will be paid as Extra Work.

201.11.04 Type D - All Other Materials – Type D shall include all other materials of a nature not included in the foregoing definitions of Type A, Type B, or Type C; regardless of the nature or condition of the material or the method used to excavate or remove.

Type D shall also include any unsuitable materials of an organic nature, unless such materials have been specifically set apart in the Special Provisions of the contract.

201.12 Unsuitable Material – Only material acceptable to the Ministry Representative shall be used in the embankments.

Material that is unsuitable for the construction shall be removed and disposed of as ordered. Any such material subsequently placed in an embankment, without the approval of the Ministry Representative, shall be removed and disposed of, as directed by the Ministry Representative, and no payment will be made for the removal or haul of such unsuitable material from the embankment.

All topsoil and organic material shall be stripped from the over the entire excavation and fill areas, and placed in the area between the highway and the right-of-way boundary, or on any other area designated by the Ministry Representative.

All material above or below subgrade in an excavation or in the foundation of an embankment, which in the opinion of the Ministry Representative is unsuitable, shall be removed and paid for as excavation, as classified by the Ministry Representative. Soft clays and peats are examples of normally unsuitable materials.

Backfilling, where required, shall be carried out with approved materials, as ordered by the Ministry Representative. Payment for such backfilling and haul will be made at the unit prices bid for "Roadway and Drainage Excavation.

Upon completion of the road grade, all topsoil and organic material suitable for growth of ground cover shall be spread on the cleared right-of-way and up the fill slopes to generally blend in with the cross-section. Care shall be taken that proper drainage is maintained. This topsoil shall be trimmed to a neat appearance preparatory to seeding by others. No additional payment will be made for replacing and trimming topsoil except that haul in excess of 300 m will be paid in accordance with SS 201.45, SS 201.83 and SS 201.93.

201.14 Surplus Material – All excavation shall, if required, be taken or hauled into the nearest embankment and to any embankment on the road to be constructed out to the extreme distance required by the Ministry Representative. The surplus beyond what is necessary to form the nearest embankment shall be disposed of in widening this embankment uniformly along one or both sides of the same, or shall be hauled to form or widen any

ROADWAY AND DRAINAGE EXCAVATION

embankment on the road to be constructed, as the Ministry Representative may direct. No material shall be wasted, all surplus material shall be used as much as possible.

CONSTRUCTION

201.31 Rock Cuts – See SS 204.

201.32 Overhanging Rock and Boulders – The Contractor shall remove overhanging rock or boulders within the excavation limits, as ordered by the Ministry Representative, and shall backfill and compact all resulting cavities. Such work will be paid at the unit price for "Roadway and Drainage Excavation."

201.33 (Not used)

201.34 (Not used)

201.35 Enlargement of Excavation – In cases where the quantity of material taken from a regular excavation will not be sufficient to form the required embankment, the deficiency shall be supplied by taking material from excavation within or outside the right-of-way, at such places as the Ministry Representative may direct, or from enlargement of the regular excavations made uniformly on one or both sides. The sides of the excavation in all cases shall be dressed to such slopes as the Ministry Representative may require, provided that if the Contractor shall have sloped or scaled such excavation by direction of the Ministry Representative before widening the same, payment for sloping or scaling the second time will be made by Order for Extra Work.

201.36 Rock Embankments – This section applies to embankments constructed from material containing more than 15% by volume of rock larger than 150 mm.

Embankments shall be constructed in layers equal in thickness to the largest size of the material but not exceeding 0.7 m. Greater lift thicknesses will be permitted by the Ministry Representative under special conditions provided the Contractor can spread the larger material satisfactorily.

The material shall be deposited and spread so that the larger rocks are well distributed and the intervening spaces are filled with smaller sizes as may be available to form a stable embankment. The finer portion of excavated rock shall be retained for the top transition layer. Each layer shall be compacted by routing the loading construction equipment over the entire width.

When a rock embankment is overlain by an earth embankment or by sub-base or base course materials, the top 0.5 m of the rock fill shall be sealed with smaller rock particles and suitable soil materials, if necessary, to prevent the uppermost layers penetrating into voids in this rock embankment.

SECTION 201

Where permitted by the Ministry Representative, and where the width is too narrow to accommodate equipment, material for the toe of the side hill rock fills may be placed by end dumping until sufficient width of the embankment has been formed to carry equipment, after which the remainder shall be placed in layers and compacted as specified. Any loose material left on the slopes by end dumping shall be incorporated in the fill and compacted.

When embankments are made on hillsides or where a new fill is to be applied upon an existing embankment, the slopes of the embankment or original ground (except rock) shall be terraced in a continuous series of steps a minimum of 1.5 m wide as the embankment rises.

The material from step excavation shall be spread and compacted into the adjoining embankment. No additional payment will be made for excavation or for placing step material in the adjoining fill.

201.37 Earth Embankments – This section applies to embankments constructed from material containing less than 15% by volume of rock larger than 150 mm. Embankments shall be constructed in such a manner that they shall be completely stable with reference to designated traffic loading.

The natural surface shall be excavated to remove organic soils or other unsuitable material, as directed by the Ministry Representative, and the removal of such material will be paid at the unit prices for the class of excavation involved.

The earth embankment shall then be constructed in successive horizontal layers not exceeding 200 mm in loose thickness except that the top 500 mm shall be constructed in layers not exceeding 100 mm in loose thickness. Each layer shall be compacted to minimum 95% of the laboratory density obtained by the current ASTM test method D 698, except in the top 300 mm of the embankment, which shall be compacted to minimum 100% of the laboratory density.

No organic soils shall be placed in the embankment. Soils that cannot be compacted to the required density because of a high moisture content shall not be employed without prior aeration and drying.

When embankments are made on hillsides or where a new fill is to be applied upon an existing embankment, the slopes of the embankment or original ground (except rock) shall be terraced in a continuous series of steps a minimum of 1.5 m wide as the embankment rises.

The material from step excavation shall be spread and compacted into the adjoining embankment. No additional payment will be made for excavation or for placing step material in the adjoining fill.

The Contractor shall be responsible for selecting equipment and methods of attaining the specified degree of compaction. In general the roller mass shall be sufficient

ROADWAY AND DRAINAGE EXCAVATION

to compress the soil vertically after each pass but not sufficient to unduly rut or shear the soil.

Water shall be added and incorporated into the soil using suitable equipment such as rotary mixers, cultivators, etc., to increase the natural moisture content to the optimum moisture percentage as determined by the current ASTM test method D 698. In the event that the natural moisture content is greater than the optimum, the soil shall be aerated and dried employing suitable mixing equipment.

201.38 Frozen Material – The use of frozen material in embankments will not be permitted; the only exception is broken rock containing less than 15% passing a 4.75 mm sieve. Frozen excavated material which will be suitable when dry shall be stored and allowed to thaw and dry, and then placed in the embankment, as directed by the Ministry Representative. No compensation will be allowed for the storing and rehandling of this material.

201.39 Snow Removal – Snow overlying the surface of a cut, or the site or surface of an embankment shall be removed and deposited beyond the slope stakes at the Contractor's own expense.

201.40 Bridge End Fill – Material for bridge end fill shall be in accordance with SS 202.04 and SS 202.05. Construction of bridge end fill shall be in accordance with SS 202.23.

201.41 Transition Sections – Subgrade, other than solid rock, shall be subcut 1 m deep at the line of transition from cut to embankment. The subcut shall taper to zero depth 8 m within the cut. The embankment construction shall be carried back over the subcut only after the embankment has reached the level of the bottom of the subcut, as measured by the Ministry Representative. Payment for the subcut will be made as "Roadway and Drainage Excavation."

201.42 Slopes and Slides – The slopes of all excavations and embankments shall be trimmed neatly and evenly to the line and slope indicated on the Drawings or as directed by the Ministry Representative.

No undercutting of slopes in excavation by power shovels or other excavation equipment will be permitted.

In case slopes, finished to the lines as shown on the Drawings, slide into the roadway or out of embankments before final acceptance of the work, such slide material shall be removed by the Contractor from the roadway or replaced by the Contractor in the embankment, as the case may be, at the unit price for the class of excavation involved. The classification of material in slips and slides shall be in accordance with its condition at the time of removal regardless of its prior condition. The slopes shall be refinished by the Contractor, as directed by the Ministry Representative. Such refishing will be paid for by Order for Extra Work. Materials to replace

SECTION 201

embankment slides shall be obtained from sources designated by the Ministry Representative.

Slopes undercut at the base or destroyed in any manner by act of the Contractor shall be resloped by the Contractor at the Contractor's expense to the slope, as directed by the Ministry Representative. All materials resulting from such resloping shall be removed and deposited, as directed by the Ministry Representative. No payment will be made to the Contractor for the removal of such material.

201.43 Ditches – Ditches which may be considered necessary for the proper drainage of the work shall be constructed at such points and to such cross-section, alignment and grade as the Ministry Representative may direct. This shall include inlets and outlets to culverts and ditching of all kinds. Ditching quantities will be considered as ordinary excavation quantities and will be measured, classified and paid for as such.

201.44 Borrow – Borrow shall consist of rut resistant material, with less than 20% passing the 0.075 mm sieve and free of organics, high plasticity clays and other unsuitable materials, obtained from an approved source of supply (e.g. pit or quarry) outside the highway right-of-way, developed and used in accordance with SS 202 Parts C and D.

The Special Provisions may identify potential sources, additional or different material qualities, or require representative sampling and testing of the material.

201.45 Haul and Overhaul – “Haul” includes all work necessary to move excavation materials from their in-situ source to any destination with a freehaul distance of 300 m.

“Overhaul” includes all work necessary to move excavation materials for that portion of the move that is beyond the limits of the 300 m freehaul zone.

Haul and overhaul shall be incidental to the Work unless specifically identified as an Item of Work in Schedule 7 – Approximate Quantities and Unit Prices.

201.46 Watering – Water for compacting embankments, constructing subgrades and surfacing, and for laying dust caused by grading operations and traffic, shall be applied in the amounts and at the places designated by the Ministry Representative. Water shall be applied by sprinkling with tank trucks equipped with spray bars and suitable control apparatus. When directed by the Ministry Representative, sprinkling shall be done at night or in the early morning hours when evaporation loss is at a minimum.

The Contractor shall make all necessary arrangements for obtaining water at the Contractor's expense.

201.47 Finishing of Roadway – Before acceptance and final payment is made, the entire roadway, including the roadbed, shoulders and ditches shall be neatly finished and trimmed to the lines, grades and cross-sections shown on the Drawings, or as directed by the Ministry

ROADWAY AND DRAINAGE EXCAVATION

Representative, to reproduce smooth surfaces, slopes and a uniform cross-section. Subgrade shall be finished within a tolerance of ± 15 mm except for rock cut fills where the tolerance shall be ± 50 mm.

All drainage ditches, waterways and culverts shall be opened up and cleaned out to restore them to their full effectiveness.

All loose rock and boulders within the right-of-way resulting from grading and grubbing operations shall be gathered up and buried, or otherwise disposed of as the Ministry Representative may direct.

The Contractor shall grade all portions of the right-of-way outside the Excavation and Embankment areas to conform to the general ground line. This work will be considered as subsidiary work pertaining to the Item of "Roadway and Drainage Excavation," and no extra payment will be made.

201.48 Surcharge Pre-consolidation –

Pre-consolidation by surcharging shall be carried out where indicated on drawings and/or Special Provisions, or as directed by the Ministry Representative. Embankments on these areas shall be placed directly on the natural ground without removal of the organic materials, unless otherwise directed by the Ministry Representative, and shall be constructed to a surcharged height above construction grade as shown or specified.

The Contractor shall be allowed to place the initial lift of embankment to a minimum depth required to carry the Contractor's hauling equipment. The remainder of the embankments shall be constructed in accordance with procedures set forth in this Section; except that compaction will not be required on the surcharge material above construction grade.

To avoid shear failures, the rate of construction shall be rigidly controlled by instrumentation installed by the Ministry.

The surcharge shall remain on the embankments a minimum of three months, or additional time as directed by the Ministry Representative, and as may be indicated by the instrumentation.

Should any of the instrumentation become damaged or rendered unusable by the construction operations, same will be replaced by the Ministry at the Contractor's expense.

201.49 Back Slope Stabilization – Drainholes, rock bolts, mesh and/or shotcrete may be required where rock is being excavated.

The backslope stabilization requirements will be assessed by the Ministry Representative during construction and the amount and location of the drainholes, rockbolts, mesh and shotcrete may be changed or deleted according to the condition of the rock encountered in the field.

SECTION 201

No adjustments in prices for changes in quantities or compensation for eliminated items will be made.

MEASUREMENT

201.81 Borrow – Borrow quantities will be measured from the source and computed in accordance with SS 145.21.01. The volume of boulders and unsuitable material removed from borrow pits that is not used in embankments shall be deducted.

201.82 Excavation – All "Roadway and Drainage Excavation" will be measured after Clearing and Grubbing operations have been completed, as specified in SS 200.01 through SS 200.03, and volumes computed in accordance with SS 145.21.01.

Pay quantities will be computed, in accordance with SS 145.21.01, in CUBIC METRE to the neat lines staked. Adjustments for curvature will be made in any cut where deemed equitable by the Ministry Representative.

201.83 Overhaul – Overhaul of excavations and embankments will be measured, for that portion of the movement that is beyond a 300 m freehaul distance from the source, on the completion of the project by the 1000 STATION METRES where a station metre (Sta. m) is 1 m³ of excavated material hauled a distance of one station (100 m). No allowance will be made for shrinkage or swell.

After allowances have been made for specific hauls which have been designated by the Ministry Representative, this information will be used to prepare a final volume overhaul diagram which will form the basis for payment of all other overhaul on "Roadway and Drainage Excavation."

PAYMENT

201.91 Borrow – Payment for BORROW materials shall be at the Contract Unit Price per cubic metre bid for "Roadway and Drainage Excavation" classified as provided for in SS 201.11. All specifications in this Section relating to excavation shall apply to borrow. Payment shall be full compensation for everything furnished and done, including without limitation costs for acquisition, development, and payment of royalties for private pits or quarries, purchase price of borrow material, access road construction and maintenance, screening, crushing, stockpiling, loading, hauling, spreading, compaction and moisture adjustment (watering or drying) in place as specified.

ROADWAY AND DRAINAGE EXCAVATION

201.92 Excavation – Payment for EXCAVATION shall be at the Contract Unit Price per cubic metre for the various types of materials excavated. The Contract Unit Price for such excavation shall include hauling the materials to any point within 300 m from the point of excavation and shall be accepted as full compensation for everything furnished and done in connection therewith.

Compensation for hauling excavation to distances greater than the free haul limit of 300 m will be paid as prescribed in SS 201.93.

201.93 Overhaul – OVERHAUL is incidental to the Work and will not be paid separately unless explicitly included as an Item of Work in Schedule 7.

Where such an Item is used, payment for OVERHAUL will be at the Contract Unit Price per 1000 station metres (Sta. m).

201.94 (not used)

201.95 Allowable Overbreak – Allowable overbreak will be paid at 75% of the Contract Unit Price for TYPE A MATERIAL. The quantity at the Contract Unit Price for overbreak in any one cut shall not exceed 10% of the original theoretical cut, as shown on the Drawings or as directed by the Ministry Representative. Material in excess of the above 10%, if used in lieu of borrow and only on the advice of the Ministry Representative, will be paid at the Contract Unit Price for TYPE D MATERIAL.

201.96 Embankment – Except where otherwise distinctly provided herein, the work described under the heading of "Embankment" will not be paid for directly as a pay item, but shall be considered as incidental work pertaining to the placement of the several classes of Excavation or Borrow and, therefore, no additional compensation will be made for the construction of embankments.

201.97 (not used)

201.98 Surcharge Removal – Payment for surcharge removal shall be at the Contract Unit Prices for EXCAVATION and OVERHAUL.

SPECIAL SLOPE TREATMENT	SP201-01
-------------------------	----------

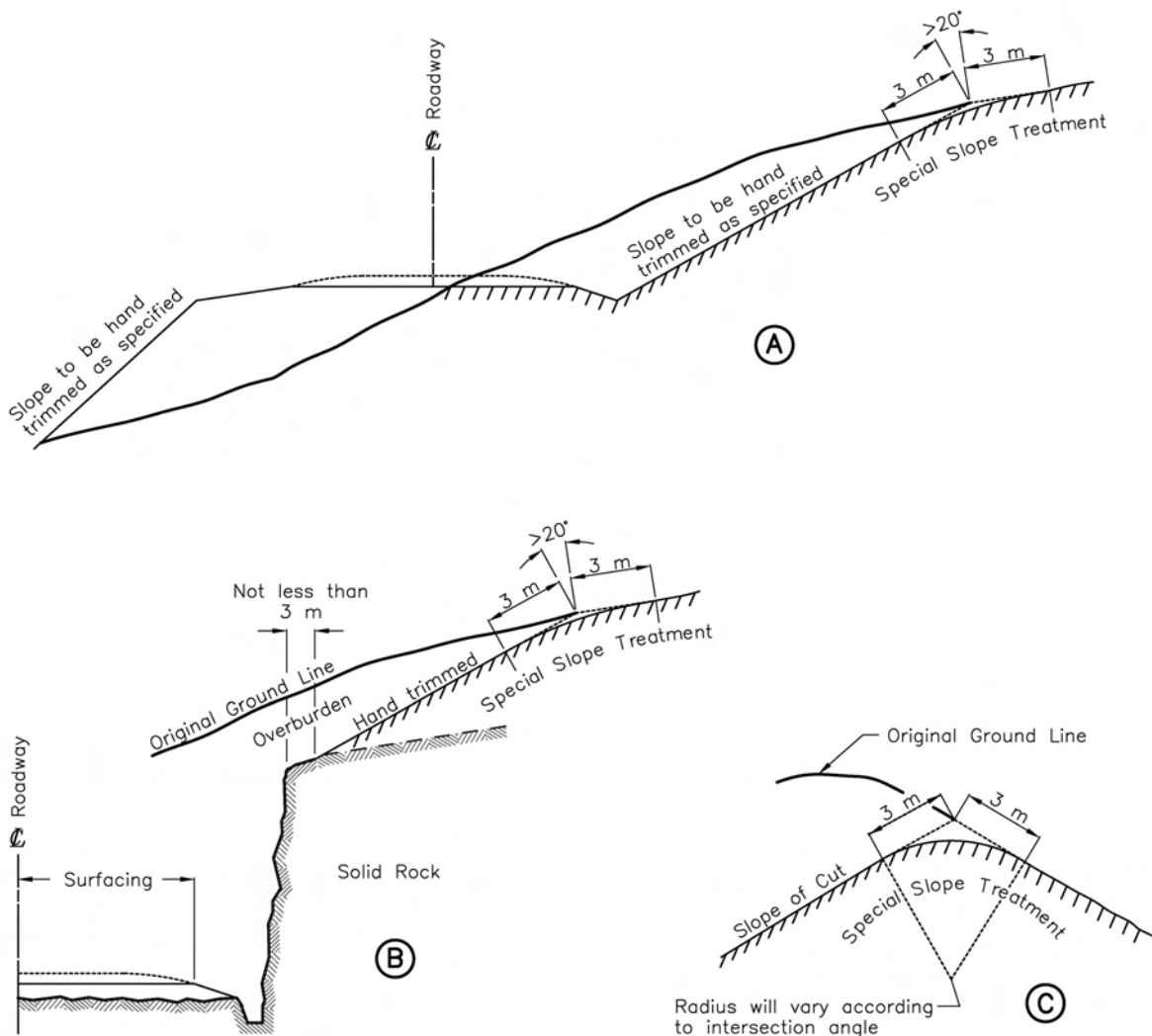

NOTES:

1. SPECIAL SLOPE TREATMENT REFERS TO THE ROUNDING OFF AT THE INTERSECTION OF CUT SLOPES WITH THE EXISTING GROUND LINE. IT SHALL BE APPLICABLE WHERE THE MATERIAL IS OTHER THAN SOLID ROCK, AND WHEN THE DIFFERENCE IN THE INTERSECTION ANGLE BETWEEN THE BACKSLOPE AND THE ORIGINAL GROUND EXCEEDS 20 DEGREES.
2. MATERIAL REMOVED IN SPECIAL SLOPE TREATMENT SHALL BE DISPOSED OF IN THE EMBANKMENTS, OR AS OTHERWISE DIRECTED BY THE MINISTRY REPRESENTATIVE.
3. PAYMENT FOR SPECIAL SLOPE TREATMENT SHALL BE MADE AT THE RATE BID PER LINEAR METRE OF SPECIAL SLOPE TREATMENT. THIS PRICE SHALL BE ACCEPTED AS FULL COMPENSATION FOR EVERYTHING FURNISHED AND DONE IN CONNECTION HERewith.

NOT TO SCALE

ALL DIMENSIONS ARE IN MILLIMETRES UNLESS OTHERWISE NOTED

SECTION 202

GRANULAR SURFACING, BASE AND SUB-BASES

PART A – SCOPE OF SPECIFICATION

202.01 Preliminary and General – This specification describes the classification, the materials and the professional standards required for the production of granular aggregates and the construction of granular surfacing, granular base and select granular sub-base.

PART B – MATERIALS

202.02 Aggregate Classification

202.02.01 Crushed Surfacing Aggregates:

i) High Fines Granular Surfacing Aggregate (HFSA): HFSA is used for surfacing of gravel roads and when paving is not scheduled for a few years. Cohesion for this aggregate is achieved by plastic fines.

202.02.02 Crushed Base Course Aggregates – These are high strength, high load bearing, high quality, crushed granular base materials. As these materials are not well suited for long-term traffic, they are usually overlaid by surface course materials (HFSA or asphalt/concrete pavement).

i) Well Graded Base (WGB): WGB is the standard base course material used for pavement structures, well graded with moderate permeability.

ii) Intermediate Graded Base (IGB): IGB is intermediate in gradation and permeability between well graded aggregate and open graded aggregate.

iii) Open Graded Base (OGB): OGB is a highly permeable, gap graded aggregate.

202.02.03 Sub-Base Aggregates – A granular material placed between the sub-grade and the base course aggregates, providing strength to the pavement structure.

Select Granular Sub-Base (SGSB): SGSB is the standard aggregate, crushed or screened, placed directly above subgrade, with moderate permeability and a wide gradation.

i) Intermediate Graded Sub-Base (IGSB): IGSB is a higher permeability, crushed sub-base aggregate.

ii) Open Graded Sub-Base (OGSB): OGSB is a highly permeable, crushed sub-base aggregate.

202.02.04 Bridge End Fill (BEF) – BEF is quality granular fill placed behind and below a bridge abutment to provide good drainage, a smooth transition from the bridge approaches to the bridge structure, and a suitable material through which to drive piles.

202.03 General Description of Work – The aggregates for granular surfacing, base and sub-base may be supplied either by the Contractor or produced from a Ministry provided source. Production of granular surfacing and

granular base requires crushing and placing in stockpile. Production of select granular sub-base may be by crushing, screening or direct excavation.

Granular aggregate shall be loaded from the stockpile, crushing and screening plant, or pit face, as may be applicable; hauled out to the highway, placed accurately without segregation and thoroughly compacted to established line and grade.

The Contractor shall maintain the prepared surface of the base course aggregate until it has been paved or until completion of the contract, whichever is applicable.

202.04 Aggregate Quality

202.04.01 General – Granular aggregate shall be composed of inert, clean, tough, durable particles of crushed rock, gravel, sand and fines capable of withstanding the deleterious effects of exposure to water, freeze-thaw, handling, spreading and compacting. The aggregate particles shall be uniform in quality and free from clay lumps, wood and free from an excess of flat or elongated pieces.

Aggregates for surfacing, base, sub-base and bridge end fill will be tested in accordance with the Table 202-A.

TABLE 202-A AGGREGATE QUALITY TESTS

BASED ON ASTM	TITLE OF TEST
C 136	Sieve Analysis of Fine and Coarse Aggregates
C 117	Wash Test of Aggregates
C 88	Soundness of Aggregate by Use of Magnesium Sulphate.
D 2419	Standard Test Method for Sand Equivalent Value of Soils and Fine Aggregate
D 6928	Abrasion Loss by Micro-Deval
D 4318	Plastic Limit Determination
BASED ON MoT	TITLE OF TEST
SS 202 Appendix 1	Fracture Count on Coarse Aggregate
SS 202 Appendix 2	Petrographic Test

TABLE 202-B AGGREGATE PROPERTIES

TEST	Test Result							Bridge End Fill BEF
	Surfacing Aggregates	25 mm Base Course			Sub-Base Aggregates			
	HFSA	WGB	IGB	OGB	SGSB	IGSB	OGSB	
Sand Equivalent	≥ 20	≥ 40	≥ 40	≥ 40	≥ 20	≥ 20	≥ 20	≥ 20
Micro-Deval loss factor	≤ 25%	≤ 25%	≤ 25%	≤ 17%	≤ 30%	≤ 25%	≤ 25%	≤ 30%
Fractured Faces Method "A"	≥ 50	≥ 50	≥ 50	≥ 50	n/a	≥ 50	≥ 50	n/a
Plasticity	≤ 6	n/a	n/a	n/a	n/a	n/a	n/a	n/a

202.04.02 Primary Quality Tests – All aggregates for surfacing, base, sub-base, and bridge end fill shall meet the requirements of Table 202-B.

Where the Ministry has pre-existing test results, the Ministry will make this information available to the Contractor and the Contractor will be able to rely on the data and not have to perform the corresponding tests on materials extracted from the investigated portions of the pit or quarry.

In circumstances where historic performance of material from a source has proven satisfactory, the Ministry may, by Special Provision, waive any or all of the testing required in SS 202.04.

202.04.03 Secondary Quality Tests – All aggregates for surfacing, base, sub-base, and bridge end fill failing any primary quality test indicated in SS 202.04.02 shall further be tested as follows to determine acceptability or, at the Contractor's option, a new source shall be found.

i) If the Micro Deval test results shows that the material fails, then the soundness shall be reassessed by use of Magnesium Sulphate (ASTM C 88). The material will be considered acceptable if the loss after 5 cycles is less than:

- 20% for coarse aggregate (the material retained on or above the 4.75 mm sieve)
- 25% for fine aggregate (the material passing the 4.75 mm sieve)

ii) If the aggregate fails any of the Sand Equivalent, Micro-Deval or Magnesium Sulphate tests, it shall be examined using the Ministry petrographic test (SS 202, Appendix 2) to determine the cause of failure. The Ministry Representative will review the test results and determine whether the material is acceptable or not.

202.05 Aggregate Gradation

Gradation shall be determined in accordance with ASTM C 136 (Dry Sieve) and, for the material passing the 0.075 mm sieve, ASTM C 117 (Wash Test).

202.05.01 Aggregate shall have a gradation that defines a curve (% passing versus log sieve size) with a slope between adjacent sieves, equal or intermediate to the corresponding slopes of the boundary curves defined by the specification. Gradations shall fall within the limits, for the specified classification, shown in Table 202-C.

202.05.02 Rut Resistance – Any aggregate supplied must, in addition to meeting the gradation requirements specified above, not rut when proof rolled with a fully loaded tandem axle truck. Any aggregate which does rut shall be removed and replaced, or blended with suitable aggregates, to meet both the gradation requirement and the rut resistance requirement.

PART C – USE OF MINISTRY-PROVIDED PITS OR QUARRIES

202.06 General – Ministry-provided pits and quarries are those identified in the Special Provisions which the Ministry is offering to the Contractor as potential aggregate sources.

They may include pits and quarries:

- owned by the Ministry
- leased by the Ministry, or
- attained by the Ministry through special agreement with the landowner.

Use of such pits and quarries will be at the Contractor's option unless the Special Provisions clearly state that the source must be used for specific purposes.

When a Ministry pit or quarry is provided for the Contractor's optional use under the Contract, the Contractor, by entering the pit or quarry, will be deemed to have accepted all obligations, risks and costs for the production of aggregate meeting the requirements of Part B of this section. The Ministry gives no warranty that its pit or quarry will meet the quality and quantity requirements.

TABLE 202-C – AGGREGATE GRADATIONS

SIEVE SIZE (mm)	Percent Passing (%) Sieve Size							
	Surfacing Aggregate	25 mm Base Course			Sub-Base Aggregates			Bridge End Fill
	HFSA	WGB	IGB	OGB	SGSB	IGSB	OGSB	BEF
75	---	---	---	---	100	100	100	100
50	---	---	---	---	---	55 – 100	70 – 100	30 – 100
37.5	---	---	---	---	---	40 – 80	50 – 85	---
25	100	100	100	100	---	---	---	---
19	85 – 100	80 – 100	65 – 100	75 – 100	15 – 100	17 – 40	15 – 55	20 – 100
9.5	60 – 85	50 – 85	30 – 70	30 – 65	0 – 100	---	---	---
6.3	---	---	---	---	---	---	0 – 20	---
4.75	40 – 70	35 – 70	15 – 40	5 – 30	---	---	---	10 – 60
2.36	---	25 – 50	10 – 30	0 – 10	---	10 – 25	0 – 10	---
1.18	20 – 50	15 – 35	---	---	---	---	---	6 – 32
0.600	---	---	---	---	0 – 100	---	---	---
0.300	10 – 30	5 – 20	5 – 15	0 – 8	0 – 15	4 – 15	0 – 8	4 – 15
0.075	5 – 15	0 – 5	0 – 5	0 – 5	0 – 5	0 – 5	0 – 5	0 – 5

Where a pit or quarry is designated as a mandatory source, the Ministry waives the aggregate quality requirements of SS 202.04.02 for aggregates required by the Ministry to be produced from that source.

202.07 Source of Supply – The Contract documents may identify one or more pits or quarries, for use as aggregate sources at the Contractor’s discretion.

The Ministry will provide those gravel pits or quarries and the right-of-way to those pits or quarries and will pay the cost of royalties, and fencing. The cost of constructing and maintaining access roads shall be considered as part of the cost of producing the construction aggregates and shall be payable by the Contractor. The Ministry will exercise its best judgement in the selection of the pit or quarry sites; however, the failure of the pit or quarry to yield materials of uniform quality shall not constitute grounds for a claim by the Contractor against the Ministry.

The Contractor shall be satisfied as to the gradation and other characteristics of the raw material in the Ministry provided pit or quarry and as to the nature and amount of work required to produce materials which will meet all gradation requirements, and the Contractor shall, at the Contractor's expense, remove any objectionable materials from the aggregate.

202.08 Development of Pit or Quarry – Before any material for aggregate is excavated from the pit or quarry, the site shall be cleared and grubbed, and all debris

disposed of as ordered by the Ministry Representative. If topsoil or undesirable overburden exist, these materials shall be stripped and placed in separate stockpiles as directed by the Ministry Representative.

The Contractor shall not operate the pit or quarry in a manner which will contaminate remaining granular material nor leave the pit or quarry in a condition which will limit its future use.

The Contractor shall follow the pit development plan, where provided. Stockpile sites in Ministry-provided sources shall be per the pit development plan.

202.09 Use of All Materials – Any Ministry provided pit or quarry, once entered and developed, shall be used to its full potential. Normally, the Contractor shall produce select granular sub-base by selection or screening, provided that oversize reject aggregate is removed and properly placed in a stockpile for later crushing and use. However, if excessive oversize occurs, the Ministry Representative may order that pit run aggregate be crushed to produce 75 mm crushed granular base for use in place of select granular sub-base.

For the production of crushed surfacing and base aggregates, as well as IGSB and OGSB, the Contractor shall provide crushing equipment such that all aggregate which will pass through 375 mm x 450 mm slotted openings shall be used for the production of crushed aggregate; rocks which will not pass through these

SECTION 202

openings shall be stockpiled or disposed of as and where directed by the Ministry Representative. Crushing and screening equipment shall be provided with adequate facilities and capacity to bleed off reject aggregate in usable condition, or otherwise remove any excess of fine aggregate, dust or objectionable aggregate coatings that may be present in or on the aggregate, so as to make it generally acceptable for use. No portion of the products of crushers or screening plants that can be used shall be wasted, but shall be stockpiled or used as directed by the Ministry Representative.

202.10 Unsuitable Materials – The rejection or addition of any particular size material necessary to produce gravel conforming to specification requirements shall be the responsibility of the Contractor, and no additional compensation will be paid therefore.

202.11 Change of Ministry Provided Pit or Quarry – No payment will be made to the Contractor for moving plant from one Ministry provided pit or quarry to another Ministry provided pit or quarry.

If, in the opinion of the Ministry Representative, a saving in haul can be accomplished, or Ministry provided pits or quarries are inadequate or unsuitable, additional sources of aggregate will be acquired and developed at the Ministry's expense.

If the Ministry Representative requires a move to a newly Ministry provided pit or quarry the Contractor will be given notice in writing. On completion of the move, the Contractor will be paid a lump sum of \$7,500 for moving a crusher operation.) and its supporting trapping, stockpiling and power units, or other basic crushing set-up which includes an additional breaker or screening unit. The payment will be deemed to be full compensation for all costs and expenses of the move and set-up of the crusher. If the Contractor moves the crushing plant without first securing a written order to do so from the Ministry Representative it will be considered sufficient proof that the move was unnecessary, and no allowance or compensation will be made to cover such a move.

202.12 Pit Cleanup – When the Contractor discontinues operations in any pit or quarry, the Contractor shall trim the sides of pit excavations, waste piles and stockpiles to a 1.5H to 1V slope, or such other slope as the Ministry Representative may direct, open up such drains or ditches as may be required to prevent water standing therein, and leave the site in a neat condition, all to the satisfaction of the Ministry Representative. The trimming, sloping, ditching and draining of the pit or quarry, as well as maintenance of the access roads, shall be considered part of the cost of producing the granular aggregate and no additional payment will be allowed.

If a pit has been fully depleted and is to be abandoned, the Contractor may be requested to reshape the sides to a slope not steeper than 2H to 1V using the stockpiled overburden

GRANULAR SURFACING, BASE AND SUB-BASES

if necessary, and cover same with any topsoil previously removed and stockpiled, all as directed by the Ministry Representative. In such cases, the replacing of stockpiled overburden and topsoil will be paid for in accordance with SS 202.32.

202.13 Work in Ministry Pits or Quarries – All work in a Ministry pit or quarry will be in accordance with SS 145.26.

PART D – CONTRACTOR SUPPLIED AGGREGATES

202.14 Preliminary and General – Aggregates shall meet the requirements of SS 202, Part B.

202.15 Development and Clean Up of Private Pits or Quarries – Pit or quarry development and cleanup shall be in accordance with local and Provincial regulatory agency requirements.

202.16 Contractor to Pay All Costs – The Contractor shall bear and pay all costs including, applicable royalties, construction and maintenance of access roads to borrow sites, any move of the equipment that may be ordered or required because a pit or quarry of the Contractor's choosing proves unsuitable for production of the contracted quantity of granular aggregates meeting the requirements of SS 202.

PART E – PRODUCTION OF CRUSHED AGGREGATE

202.17 Equipment and Plant – The Contractor shall provide and maintain in good operating condition, all plant and equipment necessary to comply with the requirements of this specification. Such plant and equipment shall be of a type and capacity to ensure proper construction and maintenance of access roads, development of the pit or quarry, maximum use of the pit or quarry, production of granular aggregates to the standard of uniformity required, and adherence to the construction schedule.

Adequate sampling facilities shall be installed by the Contractor at the discharge end of the production conveyor.

The Contractor shall ensure that the plant and equipment meet the requirements of the current Pollution Control Act and Workers' Compensation Board Regulations.

202.18 Working of Pit – A pit shall be worked in such a manner as to ensure that granular material excavated and fed to the crushers, screening plants or loaders shall be as uniform as possible. This may require the use of equipment capable of deep excavating through horizontal gravel layers or carrying out selective digging or cross blending over a large area of the pit. Before commencing production, the Contractor's quality control plan shall describe the proposed method of production for the Ministry Representative and obtain the Ministry

SECTION 202

Representative's general approval.

202.19 Crushing Operations – The Contractor shall adjust the crushers and/or screening plants and provide such screens as may be necessary to produce and maintain acceptable gradations of granular aggregates.

202.20 Crusher Gradation Control

202.20.01 Design Aggregate Gradation

For each aggregate gradation classification specified for production, field and/or laboratory tests will be performed by the Contractor to select a single gradation curve within the “banana” specification (Table 202-B), the “Design Aggregate Gradation” (DAG), which will be the target for crusher control. The Contractor shall declare the DAG, in writing to the Ministry Representative, within production of the first 10% of the Approximate Quantity of a given aggregate classification.

As part of its quality assurance program and for payment purposes, the Ministry may sample the stockpile to assess aggregate gradation compliance to contractual requirements.

202.20.02 Variation Limits

The running average of four (4) consecutive tests, on each applicable individual sieve size specified in Table 202-C, must be maintained at all times within the limits specified in that Table.

The maximum permissible variation from the DAG curve, on each applicable individual sieve size specified in Table 202-C, of the mean of any four (4) consecutive tests shall also be within the limits specified in Table 202-D.

TABLE 202-D AGGREGATE GRADATION VARIATION LIMITS

SIEVE SIZE	VARIATION LIMITS (% PASSING)
4.75 mm and larger	± 5
1.18 mm to 2.36 mm	± 3.5
0.300 mm and 0.600 mm	± 2
0.075 mm	± 1

202.20.03 Field Adjustment of Design Aggregate Gradation

The Contractor may make a maximum of two (2) field adjustments to the Design Aggregate Gradation, to accommodate minor changes in pit characteristics or to enhance production efficiency.

A field adjustment to the Design Aggregate Gradation is defined as a change in declared target gradation of the

GRANULAR SURFACING, BASE AND SUB-BASES

various aggregate sizes within the specified limits shown in Table 202-C which does not require a supplementary formal review. The maximum adjustment for individual sieve sizes for each adjustment are as permitted in the Table 202-E.

TABLE 202-E – FIELD ADJUSTMENT OF DESIGN AGGREGATE GRADATION

Sieve Designation (mm)	Maximum Field Adjustment (% Passing)
19 and larger	± 3.0
9.5	± 2.5
2.36 and 4.75	± 2.0
0.600 and 1.18	± 1.5
0.150 and 0.300	± 1.5
0.075	± 1.0

A proposed Design Aggregate Gradation field adjustment shall be submitted in writing with supporting documentation (showing original DAG, current stockpile average gradation, and proposed field adjustment and the new DAG) to the Ministry Representative. Upon receipt of the proposed field adjustments, the Ministry Representative will assess the adjustment for conformance with the contract requirements and notify the contractor whether or not it is acceptable in a timely fashion.

No field adjustment will be acceptable if it results in a change from the current Design Aggregate Gradation which fall outside the limits defined in Tables 202-C. The variation limits specified in SS 202.20.02 will apply to the adjusted DAG.

The Contractor shall have the moisture/density relationship established per ASTM test method D 698 for each original DAG, and one after each field adjustment thereto.

202.20.04 Declaration of a New Design Aggregate Gradation

Should there be a substantial change in the character of aggregate exposed in the pit face as the work proceeds, the Ministry Representative may authorize a change in the declared Design Aggregate Gradation, which would then also be eligible for field adjustment in accordance with SS 202.20.

A maximum of one change to the declared DAG be permitted.

202.21 Stockpiling

202.21.01 Unless it is specified in the Special Provisions or ordered otherwise in writing by the Ministry Representative, all crushed aggregates shall be stockpiled prior to use on the Highway.

SECTION 202

202.21.02 Stockpile sites shall be cleared of all vegetation, trees, brush, rocks or other debris and a uniform gravel surface prepared before the stockpile material is deposited on the stockpile site.

202.21.03 Stockpiles shall be constructed on the designated site and when completed shall be neat and regular in shape, occupying as small an area as is practicable. Spilling of material over the edges of the piles will not be permitted.

202.21.04 The Contractor shall ensure that stockpiles shall be built up in layers not to exceed 1 m in thickness.

202.21.05 The Contractor shall ensure that plank or protected runways shall be provided for operating trucks on stockpiles when the Ministry Representative deems them necessary to prevent dirt being tracked onto the crushed aggregate.

202.21.06 The Ministry Representative may, on receipt of a written request from the Contractor, permit the Contractor to build the final stockpile by bulldozing the aggregate from a feed pile at the end of a production belt provided that the following are maintained:

- i) The bulldozer(s) to be used shall be equipped with U-shaped pushing blades.
- ii) The aggregate does not become contaminated with oversize material, mud or other objectionable material picked up from the pit floor or general working areas.
- iii) The crushed granular aggregate is distributed evenly over the final stockpile area in lifts not greater than 150 mm in depth.
- iv) The cone of the feeder pile at the end of the production belt shall not, without express permission, be allowed to build up to a greater height than 2 m.
- v) No appreciable segregation or degradation shall occur in the main stockpile as a result of using this method.

PART F – CONSTRUCTION METHOD

202.22 Weather and Job Conditions

202.22.01 No construction shall be undertaken during snow, heavy rain, freezing or other unsuitable conditions. Aggregate shall not be placed upon a frozen, wet, muddy or rutted sub-grade, sub-base, base or surface unless otherwise directed by the Ministry Representative.

202.22.02 When the sub-grade is soft due to excessive moisture, the placing of granular sub-base shall be stopped until rutting or displacement of the lower layers can be prevented by reduced loading or by other means approved by the Ministry Representative.

202.23 Bridge End Fill – Construction of the bridge end fill shall not commence until the Ministry Representative has assessed the pertinent foundation conditions that may affect the future stability of both the bridge and embankments and has authorized continuation of

GRANULAR SURFACING, BASE AND SUB-BASES

construction. Unless the procedure for construction is stated in the Special Provisions, the Contractor's proposed method must be submitted to the Ministry Representative for approval before commencing work.

The bridge end fill shall be laid out by extending back from the bridge abutment station, as shown on the Drawings; a distance of 8.0 m along centreline (and transversely parallel to the abutment) at finished grade and thence to a 1.5:1 backslope. The front slope, as shown on the Drawings, shall start at the bridge abutment station.

The bridge end fill shall be constructed to the subgrade elevation.

The material shall consist of mineral soil with properties and gradation in accordance with SS 202.04 and SS 202.05.

The bridge end fill shall be constructed in successive horizontal layers not exceeding 150 mm in loose thickness.

Each layer shall be compacted to a minimum 100% of the laboratory density obtained by the current ASTM test method D 698.

The determination of field density will follow a method approved by the Ministry Representative.

Payment for bridge end fill shall include supply, haul placement and compaction.

202.24 Thickness of Granular Courses – Crushed surfacing course, crushed base courses and sub-base courses shall be constructed to the specified thickness and dimensions as shown on the Contract Drawings or as described in the Special Provisions, unless otherwise directed by the Ministry Representative.

Normally, on new construction, crushed bases shall be constructed 300 mm thick (in individual lifts with compacted thickness of 150 mm) unless otherwise approved by the Ministry Representative. Additional base or sub-base granular materials will be of such thickness as may be considered necessary to provide supporting strength for the flexible pavement structure.

202.25 Construction of 75 mm Sub-Base

202.25.01 Aggregates for sub-base shall be delivered to the roadbed as uniform mixtures and shall be spread in layers without segregation, preferably through an approved aggregate spreader. Granular aggregate shall not be end dumped from trucks in piles on the grade. The Ministry Representative may permit spreading from the tailgate of trucks or from centre dump units, provided the Ministry Representative is satisfied that the work will be well controlled and segregation will not occur.

When the sub-grade below granular aggregate sub-bases consists of cohesionless sand, and written permission is granted by the Ministry Representative, a portion of the granular aggregate sub-base or base may be dumped in piles upon the sub-grade and spread ahead in sufficient

quantity to stabilize the sub-grade. Segregation of aggregates shall be avoided and the material as spread shall be free from pockets or large or fine material. Segregated materials shall be remixed until uniform.

Where the required thickness is 150 mm or less, the granular base or sub-base may be spread and compacted in one layer. Where the required thickness is more than 150 mm, the aggregate shall be spread and compacted in two or more layers of approximately equal thickness; the maximum compacted thickness of any one layer shall not exceed 150 mm. Each layer shall be spread and compacted in a similar manner. At locations where the granular base or sub-base is to be placed over areas inaccessible to the spreading equipment, the granular sub-base or base may be spread by any means to obtain the specified results.

202.25.02 Immediately following spreading, the material shall be compacted to a minimum 100% of the laboratory density obtained by the current ASTM test method D 698.

If, because of the nature of the granular aggregate, the Ministry Representative considers that the results from the above test will be unreliable or the use of the test for density measurements is impractical, then the Ministry Representative may order that each lift or course of aggregate shall be continuously and thoroughly rolled until successive passes of a vibratory roller results in an increase in density of less than 10 kg/m^3

The vibrating roller shall have a minimum steel drum diameter of 1.15 m, a minimum drum width of 1.5 m, and shall be capable of being loaded so as to have a gross mass of 20 kg per lineal centimetre of drum width.

However, so that development of new compaction equipment will not be inhibited, the Ministry Representative may give written permission for the substitution of new or alternative compaction equipment if the Ministry Representative is satisfied that such equipment will provide equal or superior compaction performance.

202.25.03 Subject to the concurrence of the Ministry Representative, the Contractor may water the sub-base aggregates as required to aid in attaining the specified density.

202.25.04 The completed surface of the Sub-base course shall conform to the required line, grade and cross section as shown on the Drawings to an accuracy $\pm 15 \text{ mm}$, neither uniformly high nor low.

202.26 Construction of 25 mm Crushed Base Course

202.26.01 Crushed 25 mm base course aggregate shall be placed on a properly prepared Sub-Base surface to such depth or at such rates as may be specified. If the Ministry Representative is of the opinion that the finished surface of the Sub-Base does not meet the requirements of SS 202.25.04 but has been thoroughly and densely

compacted and should not be disturbed, the Ministry Representative may order that the surface of the Sub-Base be corrected to the true cross section, line and grade, and within the tolerances specified by use of a levelling course of crushed 25 mm base course aggregate. In such event, the crushed 25 mm base course aggregate so used will be paid for only at the rates bid for Sub-Base, provided the same Contractor is responsible for the construction of both the crushed base, and sub base.

The 25 mm crushed base course shall be constructed in such a manner that the aggregate is neither segregated, contaminated nor degraded. End dumping will not be permitted. The thickness of the 25 mm crushed base course shall be substantially uniform and the minimum thickness shall not be less than the nominal thickness shown on the drawings or ordered by the Ministry Representative. If the Contractor is unable to provide adequate manually operated equipment or workers of sufficient skill to lay the 25 mm crushed base course aggregate within the tolerances specified, the Ministry Representative may require that the Contractor lay the aggregate through an approved electronically controlled spreading machine

202.26.02 Compaction – Immediately following spreading, the 25 mm crushed base course aggregate shall be compacted to a minimum 100% of the laboratory density obtained by the current ASTM test method D 698.

The method of compaction to be employed may be selected by the Contractor, but shall be subject to approval by the Ministry Representative

202.26.03 Watering – If required, water shall be applied to attain the specified density.

202.26.04 The completed surface of the granular base course shall conform to the required line, grade and cross section as shown on the Drawings to an accuracy $\pm 10 \text{ mm}$, neither uniformly high nor low.

202.27 Equipment for Watering – Water shall be applied from a distributor of the pressure type, equipped with a spray bar mounting nozzles similar to those used on asphalt distributors and capable of applying the water accurately and uniformly. Splash plate type distributors or those equipped with spray bars that eject fine streams of water will not be permitted. The distributor must be provided with a satisfactory means for accurately measuring the quantity of water sprayed. If the Ministry Representative so requires, measuring equipment shall be calibrated under the Ministry Representative's inspection. The Contractor shall make all necessary arrangements for obtaining water at the Contractor's expense.

202.29 Proof Rolling and Stabilization – Before acceptance, each compacted course of base course aggregate shall receive one complete coverage by the tires of a truck having a 9 tonne single axle dual tire or 17 tonne

SECTION 202

tandem axle group with dual tires with a tire pressure of 600 kPa.

Any areas where rutting or displacement occurs shall be either excavated and replaced or stabilized by the addition of suitable blending material incorporated uniformly into the base as directed by the Ministry Representative.

The supply, load, haul, placing and mixing of such stabilizing aggregates as necessary to correct deficiencies in aggregate stability shall be incidental to the Work for Base aggregates. Blending may be performed at the pit or quarry or on the highway in whichever manner the Ministry Representative may direct.

202.30 Benkelman Beam Testing – At any time during the course of the work, when considered necessary by the Ministry Representative, Benkelman Beam testing may be undertaken.

PART G – MEASUREMENT AND PAYMENT

202.31 Water Applied to the Highway – Water for compaction or dust control shall be incidental to the bid price for the granular material.

202.32 Development and Cleanup of Ministry-Provided Pits and Quarries Unless explicitly stated otherwise in the Special Provisions, no separate payment will be made for clearing, grubbing, disposal or relocation of stockpiles, debris or contaminated materials, or for any other costs of site preparation, pit development, or access, or for any delay or other cost arising from the use of Ministry-provided pits or quarries by the Contractor, and all costs thereof shall be covered in the prices for the Items under which payment is provided for the applicable materials.”

202.33 Stockpile Reject Aggregate

202.33.01 Aggregate from screening or crushing operations in a Ministry-provided pit or quarry, whether:

- i) Oversize under SS 202.09, or
- ii) Rejected at the crusher in order that the product meets the requirements of SS 202.05,

shall be stockpiled separately according to size in accordance with SS 202. Stockpiles of reject aggregate shall not be contaminated by organic or other deleterious materials.

202.33.02 No payment will be made for any reject aggregate.

202.34 Blending Materials for Stabilizing Aggregates on the Highway – Blending materials, supplied, loaded, hauled, placed and mixed into the granular aggregate on the highway to correct deficiencies in aggregate stability, will be paid for at the same rate as the granular aggregate which has to be stabilized.

Normally, no additional payment will be made to cover the costs of work required to correct stability failure in the

GRANULAR SURFACING, BASE AND SUB-BASES

aggregate unless the Ministry Representative is satisfied that such instability is inherent in the type of aggregate available to the Contractor from a mandatory use Ministry-provided pit or quarry, and that the lack of stability has not risen because of unsatisfactory production methods or improper construction practices. In these circumstances, the Ministry Representative will issue an Order for Extra Work to the Contractor to cover the additional cost of mixing blending material into the granular aggregate to correct the stability deficiency.

202.35 Crushed Aggregate Supplied in Stockpile Only – Crushed aggregates, supplied in stockpile only, will be paid for at the unit price per CUBIC METRE, measured in stockpile and computed by surface to surface or, at the Ministry Representative’s option, average end areas.

Payment at the bid price shall be accepted as full compensation for everything furnished and done to supply (where applicable), produce and stockpile the crushed aggregate.

202.36 Aggregates Supplied in Place

202.36.01 Unit Price Payment – Crushed or screen aggregates (surfacing, base and sub-base) supplied and constructed in place will be paid on a neat line basis for at the applicable unit price bid per CUBIC METRE. Payment shall be full compensation for everything furnished and done, including without limitation costs for acquisition, development, and payment of royalties for private pits or quarries, purchase price of aggregate, access road maintenance, screening, crushing, stockpiling, loading, hauling, spreading, compaction and moisture adjustment (watering or drying) in place as specified.

202.36.02 Advance Payment – Crushed or Screened Aggregates Supplied in Place – An advanced payment of the greater of 70% of the demonstrated production costs or 30% of the extended amount for the Item will be made for crushed or screened aggregates (surfacing, base or sub-base) in stockpile. No advance payment will be made for pit run aggregates.

The quantities shall be determined in accordance with SS 202.37

Recovery of the advance payment will be made on each progress estimate as the respective aggregate is subsequently withdrawn from the stockpile, with an additional adjustment on the final progress estimate for any material remaining in stockpile such that the entire advance payment is recovered.

202.36.03 Surplus Aggregate

Where actual aggregate needs on the Contract fall below the Approximate Quantity indicated on Schedule 7, the Ministry will compensate the Contractor at the rates indicated in Table 202-F for a portion of surplus aggregates produced by the Contractor which meet all the

SECTION 202

GRANULAR SURFACING, BASE AND SUB-BASES

applicable quality and gradation specifications of the contract.

TABLE 202- F COMPENSATION FOR SURPLUS AGGREGATE

Stockpile Location	Compensation for Surplus Aggregates (\$/m ³)	
	Crushed	Screened
Ministry land	\$6.00	\$3.00
Private land	\$4.00	\$2.00

For each classification of aggregate, the maximum quantity of surplus aggregate eligible for compensation shall be the Approximate Quantity of that aggregate on Schedule 7 minus the quantity of that aggregate paid on the final progress estimate.

There will be no compensation for surplus aggregate for pit run aggregates or for any portion of the production on other aggregates which are beyond the Approximate Quantity.

Where aggregates are purchased from a pre-existing commercial pit or quarry operation, there will be no

compensation for any aggregate beyond that actually used in the Contract.

Surplus aggregates in stockpile on Ministry lands are the property of the Ministry. Surplus aggregate stockpiles on private lands, regardless of compensation by the Ministry, will be the property of the Contractor.

202.37 Stockpile Volume Determination

The Ministry will determine the volume of aggregate by surveying the stockpile(s) using string-line techniques, determine volume using prismatic volumes between surfaces, and deducting 10% for stockpile loss.

Alternatively, the Ministry Representative may elect to survey using cross-section techniques and/or determine volumes using end-area volumes.

The base of the pile will be determined from a pre-stockpile survey or, where such a survey is not available, from a surface determined by the Ministry Representative as being a reasonable interpolation from the intersection of the pile sides with the adjacent ground level. Where there are two or more stockpiles of aggregate meeting the same gradation classification, the compensation will be based on the cumulative quantity of those stockpiles.

Appendix 1
Fracture Count for Coarse Aggregate
(BCH 1-13)

Purpose:

This test determines the amount of fractured material in the coarse part of an aggregate sample.

Method "A" is used for crushed granular surfacing and base aggregates.

Method "B" is used for paving aggregates.

Maximum Nominal Size (mm)	Minimum Dry Mass (kg)
37.5	4.0
25.0	2.5
12.5	1.5
9.5	1.0

Apparatus:

1. Drying oven, preferably forced draft, capable of maintaining a uniform temperature of $110 \pm 5^\circ$ C.
2. A nest of sieves of the following sizes:
Method "A": 37.5 mm, 25.0 mm, 19.0 mm, 12.5 mm, 9.5 mm, 4.75 mm
Method "B": 19.0 mm, 13.2 mm, 9.5 mm
3. Balance with sufficient capacity and accurate within 0.1 percent of the mass of sample.

Test Sample:

The sample of aggregate to be tested shall be representative, oven-dry, and reduced to an amount suitable for testing. The mass of the sample shall conform to the following:

Procedure: Method "A"

1. Sieve the coarse aggregate to be tested on the 37.5 mm, 25.0 mm, 19.0 mm, 12.5 mm, 9.5 mm 4.75 mm sieves.
2. Separate each sieve size into two groups, fractured and unfractured. Each rock in the fractured group shall have at **least one** fractured face or shall be naturally angular with sharp edges. (See Discussion 1).
3. For each sieve size, count the number of fractured rocks and the total number of rocks (fractured and unfractured).
4. Calculate and record the % fracture for each sieve size and report the total % fracture for the sample using the following formulas:

FOR EACH SIEVE SIZE: (i.e. 19 mm)

$$\% \text{ Fracture (19 mm)} = \frac{\text{Number of Fractured Rocks (19 mm)}}{\text{Total No. of Rocks (19 mm)}} \times 100\%$$

FOR THE TOTAL SAMPLE:

$$\text{Total \% Fracture} = \frac{\text{Number of Fractured Rocks (All Sieve Sizes)}}{\text{Total No. of Rocks (All Sizes)}} \times 100\%$$

Procedure: Method "B"

1. Separate the coarse aggregate to be tested from the fine aggregate by sieving it over the 4.75 mm screen.
2. Separate the coarse aggregate for each sieve size into two groups, fractured and unfractured. Each rock in the fractured group shall have **two or more** fractured faces produced by a crusher or shall be naturally angular with sharp edges. Each rock in the unfractured group shall be unfractured or fractured only in one dimension.
3. Obtain the mass of the fractured group, also the mass of the total coarse aggregate (fractured + unfractured groups).
4. Calculate and report the total % fracture for the sample using the following formula:

$$\% \text{ Fracture} = \frac{\text{Mass of Fractured Rock}}{\text{Mass of Total Rocks}} \times 100\%$$

Discussion:

-Fractured face shall be defined as a fracture in any plane whose areas is 15% or more of the largest cross-section area in a parallel plane.

-The required sample can be conveniently obtained from the separated fractions of the Dry or Wash Sieve Test.

Appendix 2

Petrographic Analysis Test

Purpose:

The purpose of the Petrographic Analysis Test is to identify the various rock types and rock characteristics in the aggregate fraction of material retained on the 9.5 mm sieve of a gravel deposit. The test is performed after a micro deval soundness test or a magnesium sulphate soundness test indicates that the granular materials are weak, non durable or suspect. The petrographic analysis test is to prove or determine the cause of the poor performance of the aggregate and to determine the extent or contributing factors of specific rock types or the extent of deleterious materials or clay particles. This information will be used to determine the possible use of the materials.

Scope:

The test should be performed by a geologist, geoscientist, professional engineer with experience in rock type identification, rock classification and gravel/aggregate sources and use. Recognized procedures for rock identification shall be used. The procedures involve simple physical and chemical tests, such as the hardness scratch test, hydrochloric acid reaction and visual surface examination assisted by magnifying lens. The predominance of easily distinguishable types in petrographic samples will permit reasonably accurate testing. Important accessories are a sample kit, the rock and mineral descriptions and a good text

Rock types are to be listed by percentage weight under the broad categories of origin (sedimentary-metamorphic-igneous) with condition descriptions (i.e. hardness, weathering and cementation). Note that the descriptions of quality regarding durability or soundness (good, fair, poor, deleterious) are vital to the test results.

Additional information on general condition including weathering, shape, porosity, coatings etc. should also be recorded.

Apparatus

- 1 Balance – 20,000 gram capacity, accuracy ± 0.1 gram.
- 2 Oven capable of maintaining 110 °C.
- 3 Sieves 19 mm (3/4 inch) and 9.5 mm (3/8 inch) and shaker.
- 4 Sample splitter with pans.
- 5 Hand-lens (10X magnification).
- 6 A ten percent solution of hydrochloric acid

- 7 Aluminum pans.
- 8 A stereoscopic microscope

Sample Preparation

A 1500 gram sample of representative aggregate passing 19 mm and retained on 9.5 mm screen is required.

1. For pit run materials, a minimum of 18 kg, or one full gravel bag of representative aggregate is required.
2. This material is oven-dried at 110°C $\pm 5^\circ$ C overnight, or for 16 hours.
3. After drying, the sample is quartered in the sample splitter.
4. A one-quarter sample is sieved to obtain passing 19 mm aggregate. Additional quarters are sieved if the initial quarter provides less than 1500 gm of the required sizes.
5. The passing 19 mm retained on 9.5 mm aggregate is mixed and 1500 grams separated by splitter.
6. Fractured materials are separated from non-fractured materials and a fracture count test shall be performed using method A (see above)
7. Following removal (by hand) of clay balls and very soft weak material, the non-fractured rocks are washed to assist visual identification of mineral characteristics. The soft fractured rocks should be washed with great care as their degradation may prevent correct identification. The clay balls and lumps shall be weighed and the percent of sample noted.

Rock Type Classification

Assignment of each particle to rock type and character is required.

Identification of specific rock type may be preceded by general identification under the major rock categories of: igneous, sedimentary and metamorphic. Following simple physical, chemical and visual tests, each particle is then identified with a specific rock type and description.

Rock types are weighed to the nearest 0.1 gram. Weights are recorded on the test sheet and the percentage of each is calculated from the total sample weight.

Comments on each rock type include descriptions of physical and chemical qualities such as:

SECTION 202

- Hardness: hard, medium, soft.
- Weathering: non weathered, slightly or intensely weathered.
- Porosity:
- Cementation: firmly cemented to friable.
- Coatings

Quality Characterization (good, fair, poor, deleterious))

Basis of Quality System

The following quality distinctions are relative estimates of a rock's physical and chemical condition and of probable engineering quality.

- Good: Particles are hard, durable, free from fracture potential, little or no capillary absorption
- Fair Particles are soft but sound and tough, medium hard, slightly to moderately weathered, have small to moderate capillary absorption, are relatively smooth and impermeable.
- Poor Particles are soft to very soft, friable, potential slaking when wetted and dried, highly fractured potential, capillary absorption moderate to high.
- Deleterious: Particles react chemically with alkali in Portland Cement causing expansion in concrete, although they may be suitable in base course.

Suitability and Remarks

A description of suitability should be stated by the individual performing the test.

GRANULAR SURFACING, BASE AND SUB-BASES

Remarks should contain information in brief on general condition: weathering, shape, porosity, coatings, angularity.

A general executive summary of rock types and conditions shall be made at the beginning of the report.

(e.g. igneous granodiorite 90 % hard, non weathered. volcanics 10% hard and fresh, Some volcanics (30% of volcanics) slightly weathered, some volcanics (5% of volcanics) are vesicular and intensely weathered and soft. No clay lumps, some particles (less than 5% of sample) contained coatings of clay.

Sample Petrographic Number

The Petrographic Number (PN) for the sample is calculated by multiplying the percentage of each of the four quality classification by the following multipliers:

- Good 1
- Fair 3
- Poor 6
- Deleterious 10

and then summing the results.

Sample Petrographic Number	Overall Sample Rating
<u>100 to 125</u>	<u>Good</u>
<u>>125 to 140</u>	<u>Fair</u>
<u>>140 to 155</u>	<u>Poor</u>
<u>> 155</u>	<u>Deleterious</u>

SECTION 204

ROCK CUTS

DESCRIPTION

204.01 Scope – This Section describes the controlled blasting techniques required to produce rock cut slopes at the locations shown on the Drawings or as authorized by the Ministry Representative. Rock shall be excavated to subgrade elevation as shown on the Drawings. The work shall be conducted, whether by blasting or other methods, in a manner that minimizes blast damage to the excavation backslope and minimizes the requirement for stabilization. The responsibility for the results of every blast lies with the Contractor. Nothing within this specification shall be interpreted to mean the Ministry accepts responsibility for the results of any blast.

204.02 Definitions

204.02.01 Backline Holes – A line of holes detonated or intermittently detonated along the specified excavation backslope.

204.02.02 Bench – A near-horizontal or shallow slope surface at the top of a near-vertical rock face where blastholes are collared.

204.02.03 Bench Width – The horizontal distance on the bench between the excavation backslope and the crest of the existing rock face. Generally this dimension defines the width of the rock to be removed and is perpendicular to the highway alignment.

204.02.04 Blast Crater – A local depression in rock formed by blasting.

204.02.05 Buffer Holes – The line of production holes located closest to and parallel to the backline holes.

204.02.06 Burden – The distance between the blasthole and the nearest free face.

204.02.07 Charge – A specific quantity of explosive such as a cartridge.

204.02.08 Controlled Blasting – Controlled blasting is the controlled use of explosives and accessories in carefully spaced and aligned production and backline drill holes to produce the specified excavation backslope within the specified excavation limits. The purpose of controlled blasting is to minimize damage to the rock backslope, to help ensure long-term stability and to minimize flyrock.

204.02.09 Controlled Delay Sequence – The delay sequence required for controlled blasting.

204.02.10 Cushion Blasting – A blasting method whereby the production holes are detonated before the backline holes.

204.02.11 Delay – A blast initiator with a specific delay time period before detonation.

204.02.12 Excavation Backslope or Smooth Wall – This is the location of the free surface or shear plane in the rock produced by blasting along the backline holes.

204.02.13 Excavation Limits – This is the boundary within which rock is removed.

204.02.14 Explosive Decoupling – The separation of an explosive charge from the wall of the blast hole.

204.02.15 Flyrock – The throw of fragmented material during blasting.

204.02.16 Free Face – The rock face that provides relief for a blast.

204.02.17 Guide Holes – Those holes along the backline that are not loaded with explosive and are not stemmed.

204.02.18 Hole Deviation – Borehole misalignment distance measured in two directions, within and perpendicular to the excavation backslope. Within the plane of the excavation backslope, hole deviation is borehole misalignment as measured by the horizontal offset distance between any point in the design hole location and the point at a corresponding depth in the actual hole. Perpendicular to the plane of the excavation backslope, hole deviation is the horizontal offset distance between the plane of the design excavation backslope and the centreline of the borehole being measured.

204.02.19 Lift – The vertical distance between the top and bottom of an area to be blasted.

204.02.20 Overbreak in Rock – Overbreak in rock is any rock outside of the specified excavation limits (except slide material described in SS 201.42) that is excavated, displaced or loose due to the inherent character of any formation encountered or due to any other cause.

204.02.21 Overburden – This is Type B, C and/or D material (as described in SS 201.11) overlying rock.

204.02.22 Presplit (or Pre-Shear) Blasting – A blasting method whereby backline holes are detonated before production holes are detonated.

204.02.23 Production Blasting – Blasting of production holes detonated in a controlled delay sequence.

204.02.24 Production Holes – All holes within the specified excavation limits that are not backline holes. Production holes are often more widely spaced than backline holes.

204.02.25 Rock Excavation – Rock excavation includes drilling holes, loading holes with explosives, detonation by controlled blasting, mucking to subgrade and ditch level, and removal of material to a designated area. Rock excavation also includes secondary breakage of oversize

rock.

204.02.26 Rock – Rock is Type A material as defined in SS 201.11.01.

204.02.27 Scaling – The removal of all loose material using scaling bars, portable hydraulic jacks, other hand tools, wire rope cables, compressed air blow pipes, blasting without the need for drilled holes and other methods authorized by the Ministry Representative.

204.02.28 Setback Distance – The setback distance is the horizontal distance between the top of the excavation backslope and the toe of the overburden material. Setback is created by removing overburden.

204.02.29 Spacing – The distance between blastholes perpendicular to the burden.

204.02.30 Stemming – Material placed on top of the explosive to provide confinement of the explosive gases.

204.02.31 Subdrill – The distance drilled below subgrade level.

204.02.32 Trimming – The removal by drilling and controlled blasting of potentially unstable rock remaining at the exposed excavation backslope. Trimming may not require backline holes.

204.03 Quality Control

204.03.01 General – Quality control shall be conducted for all blasting operations.

204.03.02 Blasting Consultant – The Contractor shall retain a blasting consultant, acceptable to the Ministry Representative, to provide quality control. The consultant shall not be an employee of the Contractor, explosives manufacturer or explosives distributor.

204.03.03 Vibration Specialist – The Contractor shall retain a vibration specialist to provide blast vibration monitoring if required. The specialist shall not be an employee of the Contractor, explosives manufacturer or explosives distributor.

204.03.04 Quality Control Activities For Blasting Operations – Quality control for blasting operations shall be performed for test sections, full scale blasting operations and trimming. The Contractor shall provide to the Ministry Representative a copy of the field report generated by the Consultant within one day of each site visit by the Consultant. Quality control for blasting includes, but is not limited to the following activities by the blasting consultant:

- Viewing the proposed blast area at least one (1) week before drilling operations commence.
- Preparing and submitting blast designs for production and backline holes.
- Intermittently viewing the site during drilling for each blast area.

- Intermittently observing the loading of holes with explosives and tying in to the delay system.
- Observing the blasts and reviewing the excavated areas.
- Attending on site to view the excavation backslope after each lift and reviewing excavation backslope for quality control purposes.
- Viewing the site while reviewing proposed changes to the blast design and preparing new designs.
- Attending on site at other times as are appropriate to assist the Contractor in the setting up, assessment and adjustment of the various procedures to be employed for blasting.
- Preparing a field report for each site visit, including details of the progress of blasting operations, a statement whether the blast design is being complied with, any changes to the blast design, any recommendations made to the Contractor and any problems encountered by the Contractor.

204.04 Submittals

204.04.01 General – Review of submittals by the Ministry shall not relieve responsibility from the Contractor for the accuracy and adequacy of the submittals. Submittals are for quality assurance and record keeping purposes. Inadequate or incorrect submittals will be returned for revisions prior to acceptance. The Contractor shall submit to the Ministry Representative the following documentation for review.

204.04.02 Qualifications and Experience of Contractor – Prior to the pre-construction meeting, the Contractor shall provide a statement of the qualifications, experience and work function of all personnel assigned to drilling and blasting duties. A statement of previous work experience on similar projects shall also be provided. This statement shall include the project name, location, volume of rock, year constructed and the owner/client contact name. The company, the driller and the blaster shall each have a minimum of 5 consecutive years demonstrated experience in drilling and controlled blasting work on at least 3 projects involving rock cuts over 8 m height along transportation corridors.

204.04.03 Qualifications and Experience of Proposed Blasting Consultant – By the pre-construction meeting, the Contractor shall provide the name of the consulting firm, and the name and qualifications of the blasting consultant's on-site representative who will be providing the quality control for rock excavation. The blasting consultant shall have a minimum of 5 consecutive years demonstrated experience in preparing successful blast designs along transportation corridors for at least 3 projects. The following information shall be included in the qualifications submitted:

- Project name, location and experience.

- Name and phone number of owner/client contact who can verify the experience of the blasting consultant's site representative.

204.04.04 Qualifications and Experience of Proposed Vibration Specialist – By the pre-construction meeting, the Contractor shall provide the name and qualifications of the vibration specialist who will be providing the quality control for rock excavation. The vibration specialist shall have a minimum of 5 consecutive years demonstrated experience in the field of vibration monitoring for at least 3 projects. The following information shall be included in the qualifications submitted:

- Project name, location and experience.
- Name and phone number of owner/client contact who can verify the experience of the vibration specialist.

204.04.05 Proposed General Construction Plan – By the pre-construction meeting, the Contractor shall submit a general construction plan showing proposed blasting sequence numbers defining the order of blasts for the contract. The plan shall also show the following information for each blast:

- Blast sequence number.
- The location of the blast in relation to the remaining rock on the site.
- Approximate dimension of the rock to be removed.
- Estimated volume of rock to be removed.
- Location of the disposal site.

204.04.06 Sequence of Operations – The Contractor shall adopt a logical, systematic sequence of operations to ensure blasting is conducted safely and effectively. The following general sequence of blasting operations outlines minimum requirements of the Contractor to maximize the stability of the excavation backslope and does not limit or supercede any other requirements in this specification:

- Retain a blasting consultant to perform quality control.
- Submit blast designs for review and authorization by the Ministry.
- Accurately survey locations of proposed blastholes.
- Drill holes, load explosives, detonate blast and remove muck pile.
- Check the excavation backslope to determine hole offsets, hole angles, hole alignment and compliance with allowable tolerances.
- Review blast results and make changes to blasting operations as necessary.
- Perform backslope stabilization to the satisfaction of the Ministry Representative before subsequent lifts are detonated.

204.04.07 Blast Design – The Contractor shall provide

and follow a blast design, approved and signed by the blasting consultant, not less than one week prior to commencing drilling and blasting operations and a minimum of one day before the Contractor proposes to implement any changes to the previously utilized drilling or blasting methods. The design may be prepared by the blaster, but shall be reviewed by the Contractor and forwarded to the blasting consultant for signing. The design shall contain full details of the drilling and blasting patterns and controls that the Contractor proposes to use for controlled blasting. The blast design shall contain the following minimum information:

- Date the design was prepared and proposed date of blast.
- Station limits of proposed blast.
- Plan and section views of proposed drill pattern including free face, burden, blasthole spacing, blasthole diameters, blasthole angles, lift height, hole depth, and subdrill depth.
- The location of production (including buffer) and backline holes.
- Loading diagram showing type and amount of explosives, primers, initiators, and location and depth of stemming.
- Initiation sequence of blastholes including delay times and delay system.
- Manufacturer's data sheets for all explosives, primers, delays, and initiators to be used.
- Blasting consultant's signature, printed name, and company name.
- Blaster's signature, printed name, company name, and blaster's certificate number.

204.04.08 Preblast Survey – The Contractor shall conduct a preblast survey a minimum of one day before blasting operations commence. The preblast survey shall include a complete description of the existing condition of any nearby buildings, structures, wells and utilities that potentially may be damaged by blasting operations. The survey method used shall be acceptable to the Contractor's insurance company.

204.04.09 As-Built Blast Design – Within one day after each blast, the Contractor shall submit, unless otherwise authorized by the Ministry Representative, an as-built blast design showing all actual blast details in a format that permits direct comparison with the proposed blast design.

204.04.10 Blasting Consultant's Field Report – The Contractor shall provide the blasting consultant's field report within one day after each visit by the blasting consultant.

204.04.11 Vibration Control Records – As required, the Contractor shall provide all seismograph records of

vibration monitoring and interpretation of results within one day after each blast.

204.04.12 Peak Overpressure Records – As required, the Contractor shall provide a permanent signed and dated record of the peak overpressure measurements within one day after each blast.

MATERIALS

204.11 Explosives and Related Products

204.11.01 Manufacturer – All products and materials used for any blasting operations shall be products of a company regularly engaged in the manufacture of explosives and related products.

204.11.02 Expired Explosives – Explosives with an expired shelf life shall not be used.

204.11.03 Water Resistance – Water resistant explosives may be required for the work.

CONSTRUCTION

204.31 Permits and Regulations – The Contractor shall obtain all necessary permits for and shall comply fully with the laws, rules and regulations of Municipal, Provincial and Federal agencies in connection with the use, transportation, storage and safe handling of all explosives, including those regulations contained in the Industrial Health and Safety Regulations (IHSR) published by the Worker's Compensation Board (WCB) of British Columbia.

204.32 Supervision – The Contractor shall provide at least one person thoroughly trained and experienced in the use of explosives who shall be present at all times during the execution of all blasting operations and who shall direct such work.

204.33 Personnel – The Contractor shall ensure that all persons conducting blasting operations have a valid blaster's certificate issued by the WCB or is under the direct supervision of a certificate holder.

204.34 Safety – The Contractor shall meet all WCB regulations. All work shall be performed in a manner that prevents injury or harm to any personnel employed in the rock excavation area. Warning signs shall be posted and readily recognizable audible warning signals shall be used. The perimeter of the area affected by blasting operations shall be patrolled and controlled by direct voice communication. The Ministry Representative may stop work if the safety of the public is being jeopardized by the Contractor's blasting operations.

204.35 Flyrock Control – Before the detonation of any blast in areas where flying rock or other debris may result in personal injury or damage to property, the area within the excavation limits shall be covered with suitable blasting mats, soil or other equally serviceable material to prevent flyrock.

204.36 Other Damage – The Contractor shall be responsible for any damage resulting from blasting. Occupants of local buildings shall be notified by the Contractor, prior to the commencement of the blasting, as to the timing, size of blasts, types of warning and other signals.

204.37 Subgrade and Ditch Areas

204.37.01 General – The subgrade shall be constructed to ± 50 mm of the specified line and grade before the placement of Select Granular Sub-Base Material. Any pinnacles of intact rock protruding above the design subgrade elevation shall be removed.

204.37.02 Supporting Rock – The Contractor shall exercise care and use appropriate methods to prevent breaking, loosening or otherwise damaging supporting rock below subgrade level and ditch bottom. The Contractor shall be responsible for the methods used and for any damage to the rock structure resulting from the operations.

204.37.03 Drainage – Unless otherwise authorized by the Ministry Representative, excavated rock areas shall be free draining. If craters formed in rock by blasting below subgrade elevation are not free draining, then the Contractor shall provide drainage by trenching to a free outlet. These blast craters and drainage trenches shall be backfilled to subgrade elevation.

204.37.04 Shatter Zone for Drainage – Unless otherwise authorized by the Ministry Representative, drainage shall also be provided by shattering the upper portion of rock below subgrade and ditches within the entire excavation limits. The shatter zone shall be 300 mm thick. A shatter zone thickness of 900 mm may be required near cut to fill transition zones for 10 m beyond the transition, or as requested by the Ministry Representative.

204.37.05 Backfill Material – Backfill shall be free draining material such as clean broken rock or coarse clean granular material from a source authorized by the Ministry Representative. All backfill shall be placed and compacted as specified.

204.37.06 Ditches – The ditches shall be formed and cleaned before any base material is placed on the subgrade.

204.38 Blasting Test Section(s)

204.38.01 General – Unless otherwise authorized by the Ministry Representative, all requirements for full scale blasting shall also apply to test sections. Prior to commencing full-scale blasting operations, the Ministry Representative may require the Contractor to demonstrate the adequacy of the proposed blast design by drilling, blasting, and excavating short test sections, up to 30 m in length, to determine which combination of method, hole spacing, timing, and charge yields acceptable results. The

length of the blast test section shall be as specified in the blast design.

204.38.02 Reduced Section Length – Where requested by the Ministry Representative, the Contractor shall use test section lengths of less than 30 m.

204.38.03 Backline Hole Spacing – The Contractor shall begin the tests by drilling backline holes 750 mm apart along the specified excavation backslope, then adjust if needed, until the Ministry Representative authorizes the spacing to be used for full-scale blasting operations.

204.38.04 Review of Test Section Results – The Contractor shall not drill beyond the test section until it has been excavated and the results reviewed by the blasting consultant and continuation is authorized by the Ministry Representative.

204.38.05 Revision of Methods – If either the blasting consultant or the Ministry Representative determines that the results of the test section are unsatisfactory, then notwithstanding the Ministry Representative's prior review of such methods, the Contractor shall adopt such revised methods as are necessary to achieve the required results.

204.38.06 Additional Test Sections – If at any time during the progress of the work the methods of drilling and blasting do not produce the required excavation backslope geometry within the tolerances specified for backline holes, then the Contractor will be required to drill, blast and excavate short sections, not exceeding 30 m in length, until a technique is achieved that will produce the desired results.

204.39 Overburden Removal and Setback – The setback distance shall be 3.0 m. Unless otherwise authorized by the Ministry Representative, the Contractor shall, before drilling the backline holes, remove all overburden within the excavation limits or 10 m beyond the limits of the production holes in a direction parallel to the backline. The overburden surface shall be sloped at 1.5:1 unless otherwise authorized by the Ministry Representative.

204.40 Backline and Production Holes

204.40.01 Stemming – The upper portion of all holes between the topmost charge and the hole collar shall be stemmed. Stemming materials shall be sand or other inert angular granular material with similar specific gravity passing a 9.5 mm sieve.

204.40.02 Hole Obstructions – Before placing charges, the Contractor shall determine that the hole is free of obstructions for its entire depth. All necessary precautions shall be exercised so that the placing of the charges will not cause spalling of material from the walls of the holes.

204.40.03 General Orientation – All holes shall be drilled downward unless otherwise specified in the blast design and authorized by the Ministry Representative. In

general, slash holes (horizontal, near horizontal or fanned out holes) shall not be drilled along the excavation backslope or on pioneering routes excavated to provide access for backline hole drilling, unless authorized by the Ministry Representative.

204.40.04 Insertion of Explosive – Explosive materials shall not be inserted into the holes until the blast design has been reviewed by the Ministry Representative.

204.41 Backline Holes

204.41.01 General – The Contractor shall control the hole layout and drilling operations using proper equipment and techniques to ensure that backline holes are located and oriented correctly. The proposed location of each backline hole shall be accurately surveyed and staked.

204.41.02 Hole Location – For each blast, the line of backline holes shall extend 10 to 20 m beyond the limits of the production holes to be detonated or to the end of the specified excavation backslope, as applicable.

204.41.03 Hole Location Tolerance – Backline holes shall be drilled within 75 mm of the staked collar location.

204.41.04 Hole Deviation – Backline holes shall not deviate from the plane of the specified excavation backslope by more than 150 mm as measured perpendicular to the slope. Backline holes shall not deviate more than 150 mm as measured within the plane of the excavation backslope

204.41.05 Hole Diameter – The backline holes shall be 50 to 75 mm in diameter, or as recommended by the blasting consultant and authorized by the Ministry Representative. Trim blast holes may be as small as 25 mm diameter.

204.41.06 Hole Length – The length of backline holes for any individual lift shall not exceed 8 m unless the Contractor can demonstrate to the Ministry Representative that the Contractor can stay within the tolerances and produce the required excavation backslope geometry.

204.41.07 Guide Holes – Guide Holes shall be of the same diameter and drilled in the same plane and to the same tolerance as the remaining backline holes.

204.41.08 Hole Length Increase – Upon satisfactory demonstration, the length of holes may be increased to a maximum of 12 m with written authorization of the Ministry Representative. If more than 5% of the backline holes are misaligned in any one lift, then the Contractor shall reduce the height of the lifts until the 150 mm alignment tolerance is met.

204.41.09 Control of Drilling Orientation – All drilling equipment used to drill the backline holes shall have mechanical devices attached to that equipment to accurately determine the orientation of the drill steel entering the rock. Backline hole drilling will not be permitted if these devices are either missing or inoperative.

204.41.10 Offset Between Lifts – When the cut height requires more than one lift, a maximum 0.5 m offset between lifts is permitted to allow for drill equipment clearances. The Contractor shall begin the backline hole drilling at a point on the top lift which will allow for necessary offsets and shall adjust at the start of lower lifts to compensate for any drift which may have occurred in the upper lifts.

204.41.11 Length for Toe Berm Removal – Drilling 0.5 m below ditch bottom is permitted to facilitate removal of the toe berm.

204.42 Presplit Blasting

204.42.01 General – As conditions permit, unless otherwise specified in the blast design and authorized by the Ministry Representative, presplit blasting shall be conducted for all blasting to the excavation backslope. In general, cushion blasting may proceed when the bench width is less than three times the lift height.

204.42.02 Explosive Type and Accessories – Drill hole conditions may vary from dry to filled with water. The Contractor shall use explosives and blasting accessories appropriate for the drill hole conditions encountered to accomplish the specified results. Only standard explosives manufactured for presplit blasting shall be used in backline holes, unless otherwise specified in the blast design and authorized by the Ministry Representative. Bulk ammonium nitrate and fuel oil (ANFO) shall not be loaded into the backline holes.

204.42.03 Explosive Decoupling – Explosives shall be evenly distributed and decoupled to the maximum extent possible.

204.42.04 Explosive Charges – The bottom charge of backline holes may be larger than the remaining charges but shall not be large enough to cause overbreak. The top charge of backline holes shall be placed far enough below the collar and be sufficiently small to avoid overbreak and heaving of rock beyond the excavation backslope.

204.42.05 Modified Blasting Sequence – The Contractor may detonate the backline holes before drilling production holes, provided satisfactory excavation backslopes are obtained.

204.42.06 Backline Hole Delays – If required to reduce ground vibrations or noise, backline holes may be delayed, provided the effective hole-to-hole delay time is not more than 25 ms.

204.42.07 Excavation Backslope Geometry – The excavation backslope shall not deviate more than 150 mm from a plane passing through adjacent drill holes except where the character of the rock is such that, as determined by the Ministry Representative, irregularities are unavoidable. The 150 mm tolerance shall be measured perpendicular to the plane of the slope. In no case shall any portion of the slope encroach on the ditch.

204.43 Cushion Blasting

204.43.01 General – Where the horizontal distance from the specified excavation backslope to the existing free face is less than 5 m, the Contractor may use cushion blasting instead of presplit blasting.

204.43.02 Delay Time – The difference in delay time between the backline holes detonated after the buffer holes shall be between 25 and 75 ms. With the exception of these criteria, requirements for presplit blasting shall also apply to cushion blasting.

204.44 Production Blasting

204.44.01 Hole Diameter – Production holes shall not exceed 150 mm in diameter, unless otherwise specified in the blast design and authorized by the Ministry Representative.

204.44.02 Hole Location – Production blast holes (not including buffer holes) shall not be drilled closer than 2.0 m to the backline holes, unless otherwise specified in the blast design and authorized by the Ministry Representative. The bottom of the production holes (including buffer holes) shall not be lower than the bottom of the backline holes.

204.44.03 Delay Sequence – All sequences shall be delayed in such a manner that successive delays promote the movement of rock in the direction of a free face at all times.

204.44.04 Damage to Backslope – It is the Contractor's responsibility to take all necessary precautions during production blasting to minimize blast damage to the excavation backslope.

204.44.05 Buffer Holes – A line of buffer holes shall be drilled along a plane parallel to the backline holes. Buffer hole diameters shall be between 50 and 75 mm unless otherwise specified in the blast design. Unless otherwise specified in the blast design, the line of buffer holes shall be drilled approximately 1 m away from the backline holes and spaced 1.0 to 1.5 m centre to centre.

204.44.06 Buffer Hole Charge and Detonation – The explosive charge in buffer holes shall not exceed 50% of the full explosive load that could be placed in a 75 mm diameter production hole. Detonation of the buffer holes shall be on a delay sequence toward a free face. Ammonium nitrate and fuel oil shall not be used for buffer holes unless otherwise specified in the blast design and authorized by the Ministry Representative.

204.45 Vibration Control and Monitoring

204.45.01 Vibration Control – The Contractor shall use blasting methods designed to limit the intensity of ground vibrations originating within the excavation limits. When blasting near buildings, structures, wells, utilities or other works that may be subject to damage from blast induced ground vibrations, the ground vibrations shall be

controlled using properly designed delay sequences and allowable charge weights per delay.

204.45.02 Charge Weight Per Delay – Allowable charge weights per delay shall be based on vibration levels that will not cause damage. The Ministry Representative may monitor vibration levels at the blast site by requesting trial blasts to determine actual vibration levels reached during blasting.

204.45.03 Monitoring – Monitoring shall meet ISRM standards. Whenever vibration damage to adjacent structures is possible, the Contractor shall monitor each blast with approved seismograph(s) located between the blast area and the closest structure(s) subject to potential blast damage. The geophone shall be placed as close as possible to the structure(s) but not directly above the structure(s). The seismograph(s) shall be set to record particle velocity, accelerations, and frequency in the range generally found with controlled blasting. The peak particle velocity shall be calculated as the maximum vector sum of three mutually perpendicular components of vibration. All components and peak particle velocity shall be recorded.

204.45.03 Vibration Limits – Peak particle velocity, accelerations and frequency shall not be allowed to exceed the safe limits of the nearest structure subject to potential vibration damage. The Contractor shall employ a qualified vibration specialist to establish the safe vibration limits.

204.45.04 Interpretation – The vibration specialist shall interpret the seismograph records to ensure that the seismograph data is effectively used in the control of the blasting operations with respect to the existing structures.

204.46 Air Concussion and Noise Control

204.46.01 General – When requested by the Ministry Representative, an air concussion monitoring system shall be installed in a representative location between the blasting area and the nearest structure subject to potential blast damage or annoyance. The equipment used to make the air concussion measurements shall be the type specifically manufactured for that purpose.

204.46.02 Monitoring – The air concussion monitoring system shall be set to record air overpressure on the linear setting. When requested by the Ministry Representative, human annoyance (A weight setting) and human ear response (C weight setting) shall also be recorded.

204.46.03 Overpressure – Peak overpressure shall be controlled using appropriate blasthole patterns, detonation systems and stemming to prevent venting of blasts, and to minimize air concussion and noise levels produced by the blasting operations. The contractor shall use a qualified vibration specialist to establish safe overpressure limits.

204.47 Excavation Backslope Stabilization

204.47.01 Stabilization – The excavation backslope shall

be stabilized as recommended by the Ministry's geotechnical engineer and to the Ministry Representative's satisfaction, during or upon completion of the excavation of each lift. Unless otherwise authorized by the Ministry Representative, drilling of the next lift shall not proceed until stabilization has been completed. Drilling of the next lift shall not proceed until all concerns about stability raised by the Ministry's geotechnical engineer and the Ministry Representative are addressed by the stabilization work. Stabilization shall be completed before any base material is placed upon the subgrade.

204.47.02 Stabilization Methods – Stabilization methods include scaling, trimming, the application of rock bolts, shotcrete, slope mesh, drains or other stabilization techniques recommended by the Ministry's geotechnical engineer and authorized by the Ministry Representative.

204.48 Special Use of Excavated Rock – Excavated rock of suitable quality required for walls, riprap, paving, or other special use shall be sorted and deposited in stockpiles if so requested by the Ministry Representative.

MEASUREMENT

204.81 Type A Excavation – Type A excavation will be measured by the CUBIC METRE.

204.82 Excavation Backslope (Smooth Wall) – The excavation backslope will be measured by the SQUARE METRE only where the height of the cut exceeds 2 m, and shall be measured over the entire height of such cuts. Measurement will apply to the condition of the slope prior to scaling. Measurement for payment, including measurement of smooth wall surface area, hole deviation and slope deviation, will be conducted by the Ministry.

PAYMENT

204.91 Type A Excavation – Payment for TYPE A EXCAVATION will be at the Contract Unit Price per cubic metre and will be authorized by the Ministry Representative after submittal of all documentation required in this Section. The Unit Price will be considered full compensation for the requirements of this Section.

Design slope lines including approved offsets, subgrade and ditch lines shall represent the pay lines of Type A excavation.

If so determined by the Ministry Representative, stabilization necessitated by improper blasting operations shall be at the Contractor's expense.

Trimming will be paid at the Contract Unit Price per cubic metre for TYPE A EXCAVATION.

All costs associated with blasting test sections and any revised methods necessary to produce acceptable results shall be incidental to Type A excavation.

Additional drilling, blasting and excavation required to construct subgrade to the required tolerances and

SECTION 204

ROCK CUTS

excavating, loading, hauling, placing and compacting backfill material for blast craters and drainage trenches to subgrade level shall be incidental to Type A excavation.

All costs associated with vibration control, air concussion and noise control, and all monitoring shall be considered incidental to Type A excavation.

204.92 Excavation Backslope (Smooth Wall) – Payment for EXCAVATION BACKSLOPE will be at the Contract Unit Price per square metre for only that part of the exposed cut face meeting the geometric tolerances for excavation backslope in this Section. Geometric

tolerances to be met include hole location tolerance, hole deviation, offset between lifts and deviation of excavation backslope geometry.

Scaling of loose material disturbed by blasting including removal and disposal of overbreak shall be considered incidental to payment for excavation backslope.

Where there is no Excavation Backslope (Smoothwall) Item in Schedule 7, the Excavation Backslope (Smoothwall) Work shall be performed incidental to Type A Excavation.

SECTION 204

ROCK CUTS

PROPOSED BLAST DESIGN

File #: _____

PROJECT NO. _____

(TO BE SUBMITTED NOT LESS THAN 1 DAY BEFORE DRILLING)

GENERAL:

CONTRACTOR'S NAME _____
BLASTER'S NAME _____
BLASTER'S CERTIFICATE NUMBER _____

DATE PREPARED _____
PROPOSED BLAST DATE _____
BLAST # _____

HIGHWAY# _____
BLAST LOCATION AT: _____

UTILITY PROTECTION OR STANDBY REQUIRED: (CIRCLE) YES NO

SITE DETAILS:

HEIGHT ABOVE HWY _____ (m) SLOPE ANGLE _____ (°) SLOPE LENGTH _____ (m)
ROCK TYPE _____
DISTANCE TO NEAREST STRUCTURE (UTILITY) _____ (m)

ANTICIPATED DRILLING DETAILS:

PROPOSED NO. OF BACKLINE HOLES _____ PROPOSED APPROX. NO. OF HOLES _____
PROPOSED AVG. DEPTH _____ (m) HOLE DIA. _____ (mm)
PROPOSED NO. OF ROWS _____ APPROX. HOLE SPACING _____ (m) BURDEN _____ (m)
PROPOSED MAXIMUM DEPTH _____ (m) PROPOSED HOLE INCL.: (CIRCLE) VERTICAL HORIZ. VARIABLE
PROPOSED TOTAL DEPTH _____ (m)

PROPOSED BLAST DETAILS:

EXPLOSIVE TYPE _____ EXPLOSIVE SIZE _____ mm by _____ mm
APPROX. NUMBER OF CARTRIDGES _____ APPROX. TOTAL WEIGHT _____ (kg)
PROPOSED NUMBER OF DELAYS _____ DELAY TYPE AND LENGTH _____ (ms)

INITIATION DEVICE: (CIRCLE) E.B. CAPS SAFETY FUSE OTHER (SPECIFY) _____
BLASTING MACHINE: TYPE _____ CAPACITY _____

APPROX. VOLUME OF ROCK TO BE BLASTED _____ (m³)

PROPOSED BLAST SKETCH:

SHOW THE FOLLOWING:

- SCALE
- PLAN VIEW
- CROSS-SECTION
- ROCK GEOMETRY
- APPROX. HOLE LOCATIONS
- APPROX. HOLE DEPTH
- PROPOSED TIE-IN PATTERN
- ROW BY ROW DELAYS
- DETONATION DIRECTION
- HIGHWAY LOCATION
- UTILITY LOCATION
- NORTH ARROW

PLAN VIEW:	CROSS-SECTION VIEW:
------------	---------------------

BLASTING CONSULTANT NAME _____ SIGNATURE _____ COMPANY _____

BLASTER'S SIGNATURE _____ COMPANY _____

RECEIVED BY MINISTRY REPRESENTATIVE (SIGNATURE) _____

(Use Additional Sheets if Necessary)

AS-BUILT BLASTING RECORD

File #: _____

PROJECT NO. _____

(TO BE SUBMITTED NOT MORE THAN 1 DAY AFTER EACH BLAST)

GENERAL:

CONTRACTOR'S NAME _____
 BLASTER'S NAME _____
 BLASTER'S CERTIFICATE NUMBER _____

DATE PREPARED _____
 ACTUAL BLAST DATE _____
 BLAST # _____

HIGHWAY# _____
 BLAST LOCATION AT: _____

UTILITY PROTECTION OR STANDBY USED: (CIRCLE) YES NO TYPE OF UTILITY PROTECTION _____

SITE DETAILS:

HEIGHT ABOVE HWY _____ (m) SLOPE ANGLE _____ (°) SLOPE LENGTH _____ (m)
 ROCK TYPE _____
 DISTANCE TO NEAREST STRUCTURE (UTILITY) _____ (m)

DRILLING DETAILS:

NUMBER OF BACKLINE HOLES _____ TOTAL NUMBER OF HOLES _____
 AVERAGE DEPTH _____ (m) HOLE DIAMETER _____ (mm)
 NUMBER OF ROWS _____ HOLE SPACING _____ (m) BURDEN _____ (m)
 MAXIMUM DEPTH _____ (m) HOLE INCLINATION: (CIRCLE) VERTICAL HORIZ. VARIABLE
 TOTAL DEPTH _____ (m)

BLAST DETAILS:

EXPLOSIVE TYPE _____ EXPLOSIVE SIZE _____ mm by _____ mm
 TOTAL NUMBER OF CARTRIDGES _____ TOTAL WEIGHT _____ (kg)
 TOTAL NUMBER OF DELAYS _____ DELAY TYPE AND LENGTH _____ (ms)

INITIATION DEVICE: (CIRCLE) E.B. CAPS SAFETY FUSE OTHER (SPECIFY) _____
 BLASTING MACHINE: TYPE _____ CAPACITY _____

VOLUME OF ROCK BLASTED _____ (m³)

BLAST SKETCH:

SHOW THE FOLLOWING:

- SCALE
- PLAN VIEW
- CROSS-SECTION
- ROCK GEOMETRY
- HOLE LOCATIONS
- HOLE DEPTH
- TIE-IN PATTERN
- ROW BY ROW DELAYS
- DETONATION DIRECTION
- HIGHWAY LOCATION
- UTILITY LOCATION
- NORTH ARROW

PLAN VIEW:	CROSS-SECTION VIEW:
------------	---------------------

BLASTER'S SIGNATURE _____ COMPANY _____

RECEIVED BY MINISTRY REPRESENTATIVE (SIGNATURE) _____

(Use Additional Sheets if Necessary)

SECTION 205

RIPRAP

205.01 General – This Section covers the protection by riprap of embankments and channels at the locations and of the type and class shown on the Drawings or required by the Ministry Representative.

Work within any watercourse shall generally be carried out in conformity with the environmental protection provisions to the satisfaction of the Ministry Representative.

205.02 Material – Rock shall be hard durable angular quarry rock of a quality that will not disintegrate on exposure to water or the atmosphere. The gradation of rock sizes (mass in kg) in each class of riprap, as specified or directed, shall conform to Table 205-A.

Rocks generally shall be well graded, approximately the stipulated sizes, and individual rocks shall have a thickness greater than one-third their length and none shall have a mass greater than five times that of the specified class mass.

For visual comprehension only, Table 205-B indicates the approximate average dimension of an angular rock for each specified rock class mass.

205.03 Preparation – Areas to receive riprap shall be trimmed to a uniform surface and to the slope(s) indicated on the Drawings or as directed by the Ministry Representative.

Before rock placement commences, loose material shall be removed and minor pot-holes and hollows filled with selected materials well tamped-in to the approval of the Ministry Representative.

205.04 Foundations – To provide a stable foundation and protection against any undercutting, the riprap shall be thickened at the toe, laid horizontally to form an apron and/or keyed into the bed of the watercourse, all as indicated on the Drawings or as directed by the Ministry Representative.

205.05 Filter Blankets – Filter blanket material and placement, where required, shall be as specified in the Special Provisions or as directed by the Ministry Representative.

205.06 Loose Riprap – The controlled placement of rock of the class specified shall produce a rock mass of the nominal or required thickness over the area indicated. The rock shall be manipulated as necessary to provide mass stability and a regular surface with a minimum of voids.

205.07 Hand-Laid Riprap – Hand-laid riprap, normally Class 10 or 25, shall conform to the size, gradation and requirements set out in SS 205.02. Individual rocks too large to handle shall be manipulated for satisfactory setting and spacing.

TABLE 205-A GRADATION OF ROCK SIZES IN EACH CLASS OF RIPRAP

CLASS OF RIPRAP (kg)	*NOMINAL THICKNESS OF RIPRAP (mm)	ROCK GRADATION PERCENTAGE LARGER THAN GIVEN ROCK MASS (kg)		
		85%	50%	15%
10	350	1	10	30
25	450	2.5	25	75
50	550	5	50	150
100	700	10	100	300
250	1000	25	250	750
500	1200	50	500	1500
1000	1500	100	1000	3000
2000	2000	200	2000	6000
4000	2500	400	4000	12000

* The thickness of riprap, measured at right angles to the slope, for the class specified, shall be the nominal thickness stated, unless otherwise shown on the Drawings or required by the Ministry Representative.

TABLE 205-B APPROXIMATE AVERAGE DIMENSION OF AN ANGULAR ROCK FOR EACH SPECIFIED ROCK CLASS MASS (s=2.640)

CLASS (KG)	APPROX. AVERAGE DIMENSION (mm)
10	<u>195</u>
25	<u>260</u>
50	<u>330</u>
100	<u>415</u>
250	<u>565</u>
500	<u>715</u>
1000	<u>900</u>
2000	<u>1130</u>
4000	<u>1425</u>

At the toe of sloped riprap, a sufficient number of the larger rocks shall be placed to form a firm foundation approximately 50% thicker than the required nominal riprap thickness. The remaining larger rocks shall be regularly spaced, at least one to every 2.5 m², when placing the general rock mass to the nominal or required thickness over the area indicated. Smaller rocks or spalls shall be well hammered in to fill the interstices and to form a closely massed regular surface.

Where riprap is required in two layers, the rocks shall be laid up and generally lap jointed between the regularly spaced larger rocks placed as through headers.

205.08 Grouted Riprap – Where grouted riprap is shown or required, the surfaces of the rocks shall be cleaned and wetted and the interstices filled with cement mortar, well rodded and pounded in for a minimum mortar depth of 300 mm or as otherwise detailed or required by the Ministry Representative. The mortar shall consist of one part Portland cement to three parts well graded clean fine aggregate mixed to a proper consistency.

205.09 Measurement – Measurement shall be made by multiplying the facial area by the average thickness dimensions as shown on the Drawings or as directed by the Ministry Representative. No allowance will be made

for the quantity of rock placed in excess of these dimensions.

205.10 Payment – Payment shall be on the basis of the Unit Price bid per cubic metre for the type and class of riprap specified or required. The Unit Price bid shall be accepted as full compensation for everything completely furnished and done in connection therewith, but shall not include the excavation for foundation, which shall be paid for under "Roadway Drainage and Excavation" or "Foundation Excavation", whichever is specified in the Contract.

Where the source of supply for the riprap is off-Site or outside the design excavation limits as shown on the Drawings, the Unit Price for Riprap shall include all costs to develop the source and produce the riprap.

Where the source of supply is on-Site and within the design excavation limits as shown on the Drawings, payment to excavate the rock for riprap will be included within the Contract Unit Price for Type A or Type B, as appropriate to the source.

Haul and overhaul are incidental to Unit Prices indicated above unless Schedule 7 includes an Overhaul Item.

SECTION 206

ROCK BOLTS

DESCRIPTION

206.01 Scope – This Section covers the installation, by appropriate rock bolting methods, of anchored steel bars tensioned and locked off against face plates in the areas designated by the Ministry Representative. Unless otherwise stated below, all rock bolts shall be installed and tensioned to the rock bolt manufacturer's specifications.

206.02 Codes And Standards

CAN/CSA G164	Hot Dip Galvanizing of Irregularly Shaped Articles.
CAN/CSA G30.18	Billet Steel Bars for Concrete Reinforcement
CAN/CSA G40.21	Structural Quality Steels
CAN/CSA A23.2-9C	Compressive Strength of Cylindrical Concrete Specimens.

206.03 Quality Control – The Contractor shall provide quality control for rock bolt operations.

206.04 Submittals – The Contractor shall supply the following to the Ministry Representative:

206.04.01 Proposed Rock Bolt System – Provide documentation as follows for the proposed rock bolt system for review at least 5 working days before commencing rock bolt installation.

a) Rock Bolts – Type, dimensions and manufacturer of the bar, centralizers, face plate, washer (where applicable), and nut.

b) Resin – Published specifications showing name of material, manufacturer, graph of unconfined compressive strength development versus time, gel time, viscosity, shelf life, storage and handling requirements.

c) Grout – Published specifications showing name of material, manufacturer, 7 and 28 day unconfined compressive strength, composition, shelf life, storage and handling requirements.

d) Data Sheets – Upon request by the Ministry Representative, supply the manufacturer's product data sheets.

e) Properties of Steel – Upon request by the Ministry Representative, supply the physical and chemical properties for each lot or heat number of the steel.

f) Test Results – Upon request by the Ministry Representative, submit a certified statement from an independent testing laboratory of the physical dimensions and mechanical properties of the rock bolt bar proposed for use. This statement shall include:

- Minimum cross-sectional area of the threaded portion of the bar.
- Minimum cross-sectional area of the unthreaded portion of the bar.
- Yield strength of the bar.
- Ultimate tensile strength of the bar.
- Percent elongation of the bar at yield and ultimate strength.

g) Quick Setting Mortar – Name of material, manufacturer, 7 and 28 day unconfined compressive strength, and composition.

h) Sealing – Proposed method of sealing fractures and voids in drill holes to prevent loss of grout.

206.04.02 Calibration Certificates – Provide tensioning jack calibration certificates 5 working days before commencing rock bolt installation. Calibration of jacks shall have been performed by an authorized testing agency not more than 30 days prior to rock bolt testing. The certificate shall show the relationship between gauge pressure and applied load. Pumps and jacks shall be paired for calibration.

206.04.03 Contractor's Rock Bolt Records – Provide daily rock bolt tensioning records within one day of each day's rock bolt operations. Records shall include contractor name, date of tensioning, weather, temperature, test jack identification number, pump identification number, name of person who tested the rock bolt, rock bolt location, rock bolt number, rock bolt length, resin or grout details, test start time, test end time, gauge reading for each minute of the creep test, and lock off load. For resin systems, records shall also include the start and end times of spinning the bar through the resin in the hole.

MATERIALS

206.11 Materials – Steel materials shall be hot-dip galvanized to CSA G164. All resin, grout and steel materials shall be the products of established manufacturers regularly engaged in the manufacture of rock bolt materials for at least five years. Materials shall meet the following additional requirements:

a) Rock Bolt Bars

- Steel hot-rolled Grade 517 MPa meeting CAN/CSA G30.18.
- Nominal bar diameter 22 mm unless otherwise specified.
- Threadlike surface deformations for full length of bar and suitable for mechanical coupling.

- Cut-thread reinforcing bar not permitted.

b) Miscellaneous Hardware

- Steel hardware to be compatible in size and strength with rock bolt bars.
- Face plates to be square in plan and dome shaped in cross-section.
- Face plate size to be matched to bar size.
- Face plates to CAN/CSA G40.21 Grade 300W.
- Face plate dimensions 10 mm by 150 mm by 150 mm unless otherwise specified.
- Face plates date stamped after galvanizing on the side visible when installed with the current year (in the format YYYY) in numbers 10 mm high.
- Face plates slotted for grout tube if grout is used.

c) Resin

- Fast-set and slow-set resin in cartridge form.
- A minimum unconfined compressive strength when fully mixed and cured of 90 MPa, tested in accordance with CAN/CSA A23.2-1B.
- Encased in a plastic film that provides optimum resistance to moisture, and is easily ruptured to enable complete mixing during installation.
- Suitable thixotropic and viscous properties to permit adequate mixing of the resin components by rotation of the rock bolt bar and to contain the resin within the drill hole.
- Easily identifiable gel time and as recommended by the resin manufacturer.
- Reach 80% of its ultimate strength within a time interval equal to five times the gel time.
- Non-shrink after the gel time.
- Unaffected by mild acids or mild alkalis.
- Cartridge boxes labelled with the resin expiry date.

d) Grout

- Pre-mixed, unsanded, non-metallic, and non-shrink cementitious grout containing silica fume.
- Can be mixed to a flowable consistency, typically with a water to cement ratio of 0.35 or as specified by the grout manufacturer to achieve or exceed the required strength.
- Minimum 7 day compressive strength of 30 MPa and a minimum 28 day compressive strength of 40 MPa, tested in accordance with CAN/CSA A23.2-1B.
- Admixtures to be used according to the manufacturer's specifications and as authorized by the Ministry Representative.

- Calcium chloride accelerator is not permitted.

e) Mortar Pads

- Portland cement based.
- Quick setting.

CONSTRUCTION

206.31 Execution

206.31.01 General – The entire rock bolt system shall be stored under cover away from deleterious materials. All grease and other deleterious material shall be removed from the steel prior to rock bolt installation.

206.31.02 Site Preparation – Where rock bolts may be adversely impacted, rock removal above and around proposed rock bolt locations shall be completed before installation of rock bolts commences. Any minor rock scaling performed in conjunction with rock bolting shall be considered incidental to rock bolting.

206.31.03 Drill Holes

a) Location, Orientation and Depth – The location, direction, angle and depth of the holes will be dependent on field conditions encountered and will be detailed by the Ministry Representative.

b) Hole Diameter – The diameter of the holes shall be suitable for the rock bolt system chosen. Where grout is used, the hole size shall be according to the rock bolt manufacturer's recommendations. Where resin is used, the hole size shall be according to the resin manufacturer's recommendations.

206.31.04 Cleaning – All water, grease, oil, cuttings and other deleterious materials shall be removed from finished holes by a water and/or air jet as required.

206.31.05 Sealing The Contractor shall take measures to seal fractures and voids in drill holes where necessary to prevent anchor grout loss.

206.31.06 Installation

a) General – Rock bolts shall be inserted (or rotated) into the drill holes and fully encapsulated in resin or grout to the drill hole collar. When resin is used, the bolt shall be advanced and rotated at a rate recommended by the resin manufacturer.

b) Anchorage Length – The anchorage length or bondzone shall be the last 1000 mm of the inserted end of the bar, unless otherwise specified.

c) Centralizers – If grout is used, centralizers on 3.0 m centres shall centralize the rock bolt in the drill hole before grout is placed. Centralizers shall be suitable for holes in rock and shall be specifically manufactured for rock bolt application.

d) Resin – Resin cartridges shall be installed as follows or as specified by the resin manufacturer:

- **Fast-Set Resin** – A sufficient number of fast-setting cartridges shall be placed in the bond zone at the bottom of the hole for the anchorage.
 - **Slow -Set Resin** – A sufficient number of slow-setting cartridges shall be placed in the free stressing length between the bond zone and the collar of the hole.
- e) **Grout** – Grout shall be prepared and placed as follows unless otherwise specified by the grout manufacturer:
- **Mixing** – Grout shall be mixed in a colloidal or high shear grout mixer according to the grout manufacturer's published instructions. Mixing paddles shall be slotted and perforated. Mixing time shall be not less than two minutes.
 - **Batching** – All ingredients for the grout mix shall be batched by mass. Water shall be added to the drum first and dry ingredients afterwards. Grout shall not be re-tempered after initial mixing. Grout shall be placed immediately after mixing.
 - **Grout Placement** – Grout shall be pumped using a grout tube extending to the bottom of the hole. The inserted end of the tube shall remain below the level of the grout in the hole to effect a continuous air free column as the grout level rises. Grout shall be placed quickly and continuously to avoid overworking, segregation, bleeding and disturbance of initial set. Grout that has stiffened due to delay in placing shall not be used in the work and shall be disposed of at an authorized location.
- f) **Resin and Grout** – At the Contractor's option, both resin and grout may be used to surround a rock bolt as follows. Resin cartridges may be placed in the bond zone, and grout may be used in the free-stressing length.
- g) **Rock Face Preparation** – The bearing surface shall be prepared to allow the face plate to be oriented within the limits recommended by the anchor manufacturer. If necessary, rock shall be chipped from around the face plate contact area.
- h) **Mortar Pad Construction** – Mortar pads shall be constructed as required to ensure the bar is within 20° of a line perpendicular to the face plate. Mortar pads shall be installed where face plates deform excessively under load. The pad shall not crack or deform when loaded. Sufficient time shall be provided to allow pads to achieve sufficient bearing capacity prior to test-tensioning.
- i) **End Hardware Installation**
- Nuts shall bear uniformly against the faceplate.
 - The bolt extension beyond the nut shall be 100 mm ± 10 mm.

206.31.07 Tensioning – All rock bolts shall be test-tensioned and locked off following set-up (or curing) of the bond zone and before set-up of the free stressing length. Prior to testing, the bond zone grout and/or resin shall meet the strength specified by the anchor manufacturer. The following procedure applies to 22 mm diameter Grade 517 MPa steel bars. An alternative procedure may be specified for different bar sizes.

a) **Equipment** – Equipment required for tensioning shall be supplied by the Contractor and shall be of a size adequate to provide the required tension. A torque wrench shall not be used for tensioning.

b) **Test-Tensioning and Creep Test** – Rock bolts shall be test-tensioned to 186 kN (42,000 lb). The test load shall be held for 10 minutes for the creep test.

c) **Lock-Off Tension** – Rock bolts shall be locked-off to a design tension of 140 kN (31,500 lb) after testing.

d) **Acceptance Criteria** – During the creep test a load loss of greater than 10% of the load applied shall be indicative of anchorage failure. Creep movement at the anchor head shall not exceed 2 mm during the creep test. A replacement rock bolt shall be installed at the Contractor's expense where these criteria are not met.

206.31.08 Rock Bolt Evaluation – The Ministry Representative will implement a program of evaluation of rock bolts installed. After locking off the anchor, the load shall be re-applied to determine the lift-off load. The lift-off load shall be the tension level at which the anchor nut can be loosened by hand. Lift-off tests shall be performed on rock bolts chosen by the Ministry Representative to a minimum of 5% of the total number of rock bolts. One additional lift-off test on a different bolt shall be performed for each bolt whose lift-off load is not within 10% of the specified lock-off load. Following lift-off testing, all bolts shall be locked off as specified.

MEASUREMENT

206.81 Rock Bolts – Rock bolts will be measured by the METRE installed. The measurement length shall be the length of bar in the rock.

PAYMENT

206.91 Rock Bolts – Payment for ROCK BOLTS will be at the Contract Unit Price per metre. Payment for rock bolts will be authorized after installation to the contract specifications and after submittal of the completed Contractor's Daily Rock Bolt Testing and Tensioning Record. The Unit Price will be considered full compensation for all work and materials supplied according to the requirements of this Section.

File # _____

**CONTRACTOR'S DAILY ROCK BOLT TESTING
AND TENSIONING RECORD**

PROJECT NO. _____

(TO BE SUBMITTED WITHIN 1 DAY AFTER EACH DAY'S ROCK BOLTING OPERATION)

Contractor Name _____ Date _____

Bolt Type _____ Size _____ Weight of each bag of grout (M) _____ kg Weather _____

Resin/Grout Type _____ Anchorage Length _____ m Volume of water added for each bag (V) _____ L Temperature _____ °C

Test Jack Number(s) _____ Actual Water / Cement Ratio (V/M) _____

Sample calculation for this grout:

Name of Person who Installed and Tested the Rock Bolt	Zone Area		Bolt Sequence Number for the Area	Bolt Length (m)	Bolt Rotation Time Through Resin		Test Start Time	Test Details: Record Gauge Reading of Each Minute										Lock Off Load (kN)	Test End Time	Grout Cube #	Certified Correct by Tester (Signature)		
	Start	End			Start	End		1	2	3	4	5	6	7	8	9	10						

Certified Correct: _____
(Contractor's Superintendent)

SECTION 207

SLOPE MESH FOR ROCK CUTS

DESCRIPTION

207.01 Scope – This Section applies to slope mesh structures which are installed to provide rockfall protection.

207.01.01 Rock slope scaling and tree removal, performed in conjunction with slope mesh installation, shall be considered incidental to slope meshing. Rock slope scaling and tree removal shall be completed before the mesh support system is installed unless otherwise authorized by the Ministry Representative. Trees to be removed will be detailed by the Ministry Representative.

207.01.02 Discarded mesh components, scaled rock, trees and debris generated by the slope meshing work shall be removed from the ditches and disposed of by the Contractor. Temporary storage of felled trees in ditches will not be permitted.

207.01.03 The Contractor shall layout in the field all anchor and suspension cable locations for each section. Each section will be reviewed by the Ministry Representative prior to installation.

207.01.04 Field conditions may require final anchor, cable and mesh configurations to vary from the Ministry's Drawings. All variations shall be authorized by the Ministry Representative.

207.01.05 The area to be provided with slope mesh protection shall be divided into sections with a maximum width of 24 m. Each section shall have a separate suspension cable, end main anchors and end anchors. End main anchors of adjacent sections shall be positioned 200 mm apart. The gap between sections shall be closed with mesh.

207.01.06 The maximum mesh length shall be 80 m.

207.01.07 The maximum rock impact energies shall be as follows:

- 3 kJ above cut crest
- 30 kJ below cut crest

207.01.08 Overburden thickness may range from zero to over 1.5 m.

MATERIALS

207.11 Slope Meshing Materials – Unless otherwise specified, preparation and installation of materials shall be according to manufacturer's recommendations.

All components shall be hot-dip galvanized conforming to ASTM A 123 or ASTM A 153 or CSA G164 where appropriate. Damaged galvanizing shall be re-galvanized at the contractor's expense.

207.11.01 Mesh – Mesh shall be 11 gauge (2.95 mm dia.) hexagonal triple twist gabion type mesh. Mesh wire shall meet ASTM A975 style 1 consisting of carbon steel with a class 3 zinc coating of not less than 244 g/m² meeting ASTM A641. The weight of zinc coating shall be determined by ASTM A 90. The coating shall withstand four one minute dips by the preece test, ASTM A 239. Mesh opening shall be hexagonal in shape and uniform in size measuring 80 mm by 100 mm.

207.11.02 Threadbar – Threadbar shall conform to CSA G30.18, grade 400 steel, manufactured by Dywidag Systems Int. (DSI) or authorized equivalent.

207.11.03 Eye nuts – Eye nuts shall be cast or manufactured eye nuts by DSI or authorized equivalent.

207.11.04 Cables – All cables shall be fibre core conforming to CSA G4. Cables shall be unspliced.

207.11.05 Thimbles – Thimbles shall meet FF-T-276B Type III (extra heavy G-414).

207.11.06 Clips – Clips shall meet FF-C-450 Type 1, Class 1 (G450 Crosby clip or authorized equivalent).

207.12 Grout

207.12.01 Grout for main anchors shall be Celtite Anchortite. Grout for auxiliary anchors shall be Celtite Lokset cartridges, cement grout or authorized equivalent.

207.12.02 Cement grout shall be Target 1118 or Basalite Microsil anchor grout or equivalent with W/C=0.35. Grout minimum 3 day and 28 day compressive strengths shall be 20 MPa and 40 MPa respectively, tested in accordance with CSA A23.2-1B.

207.13 Conformance Documents – Prior to installation the contractor shall supply documents of conformance to project specifications of all materials upon request.

CONSTRUCTION

207.31 Anchor Installation

207.31.01 Overburden shall be excavated to rock at anchor locations unless specified otherwise. The Contractor shall minimize disturbance of surrounding soil and rock when excavating. Cables shall not contact ground surface.

207.31.02 Anchor holes shall be a minimum of 1.5 times anchor diameter and in strong, competent rock. Anchors shall be centered in the hole and grouted. Anchors shall not be loaded within 3 days of grouting.

SECTION 207

SLOPE MESH FOR ROCK CUTS

207.31.03 Main anchors shall be located at local high points where practicable to maximize clearance between suspension cable and ground surface. Main anchors shall be vertical and centered in the hole unless otherwise authorized by the Ministry Representative. Main anchor height above ground surface may be reduced where authorized by the Ministry Representative for field conditions.

207.31.04 Auxiliary anchors shall be located to minimize potential for main anchor bending.

207.31.05 Main anchors may be substituted, where authorized by the Ministry Representative, with a limited number of guy cables directly connected to the suspension cable where no suitable main anchor locations can be found. Guy cable anchors shall be located to maximize suspension cable elevation. See Section Y-Y, on Drawing SP207-02 and Detail B on Drawing SP207-03.

207.31.06 Auxiliary or guy anchor embedded length may require extension if weak rock conditions are encountered.

207.32 Soil Anchors – Soil anchors shall be used where required or as ordered by the Ministry Representative. For soil anchor details see Drawings SP207-04 and SP207-05.

Concrete requirements for soil anchors:

- minimum compressive strength at 28 days = 30 MPa
- maximum nominal size of aggregate = 28 mm
- air content = $5 \pm 1\%$
- slump = 55 ± 20 mm
- maximum w/c ratio by mass = 0.45

Upon request by the Ministry Representative, the contractor shall load test one overburden soil anchor to 10 kN to verify capacity.

207.33 Cable and Mesh Installation – Suspension, auxiliary, end, and guy cables shall be installed to nominal tension to remove slack before and after installing mesh.

A maximum of two horizontal mesh seams (200 mm overlap) shall be permitted along the entire mesh height. The upper mesh portion shall be between the slope and lower mesh at the overlap. The horizontal seam connections shall be similar to the vertical seams.

The mesh shall terminate 1500 mm above the highway edge of pavement elevation. The bottom of the mesh shall be evenly trimmed parallel with the highway elevation. The bottom of the mesh shall be bent to remove the curl.

MEASUREMENT

207.81 Slope Mesh – Slope mesh shall be measured by the SQUARE METRE of slope meshed area.

PAYMENT

207.91 Slope Mesh – Payment for SLOPE MESH will be at the Contract Unit Price per square metre. The Unit Price will be full compensation for all requirements in this specification. Partial payment may be authorized where all components have been installed in a portion of the designated slope meshing area. No separate payment will be made for mesh overlap.

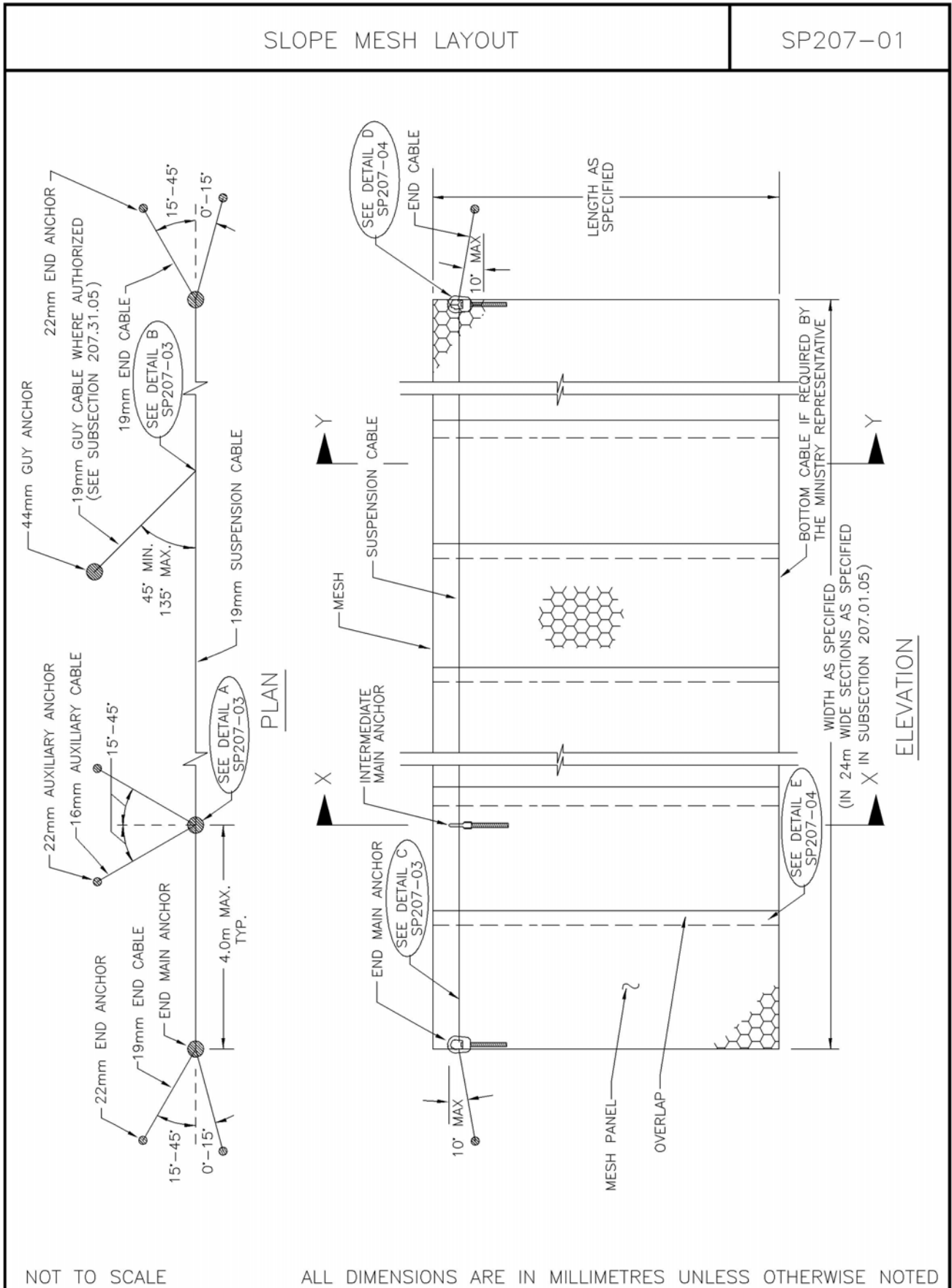

SLOPE MESH – SECTIONS

SP207-02

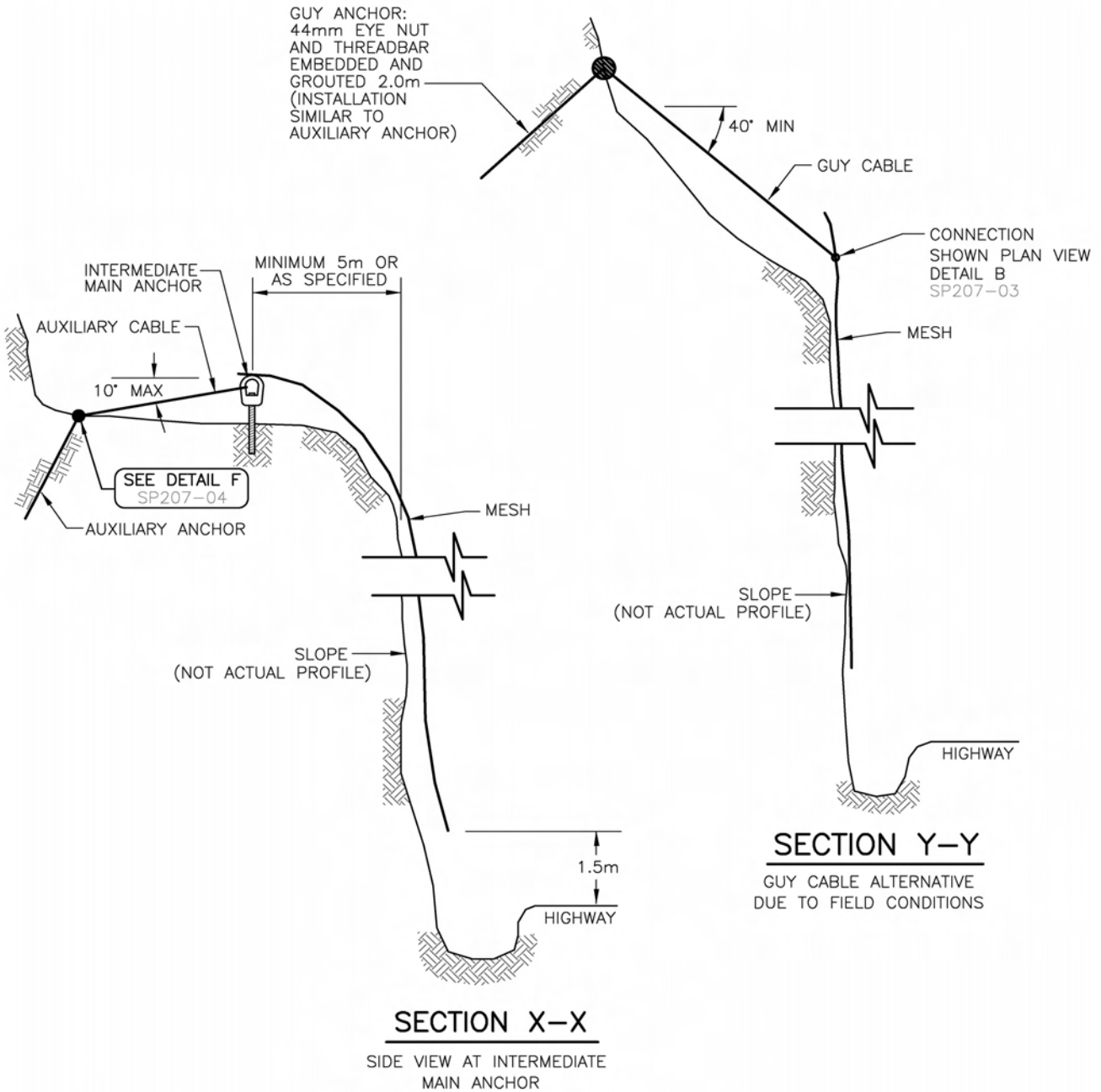

NOTES:

- 1. FOR LOCATION OF SECTIONS SEE DWG. SP207-01.

NOT TO SCALE

ALL DIMENSIONS ARE IN MILLIMETRES UNLESS OTHERWISE NOTED

SLOPE MESH – DETAILS SP207-03

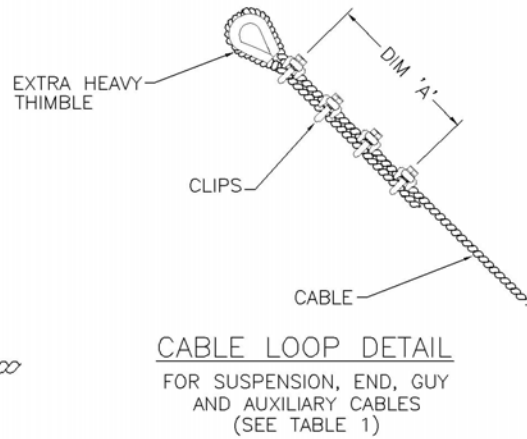
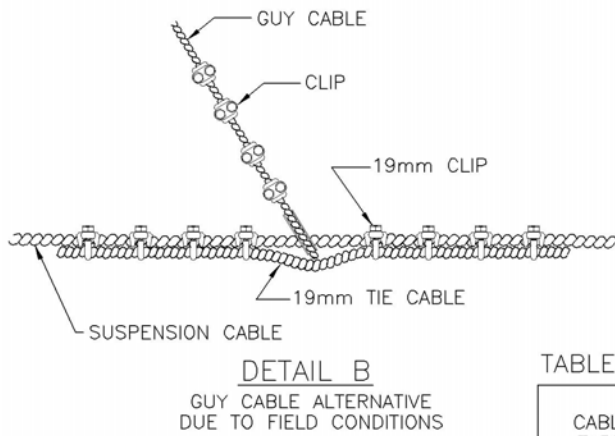
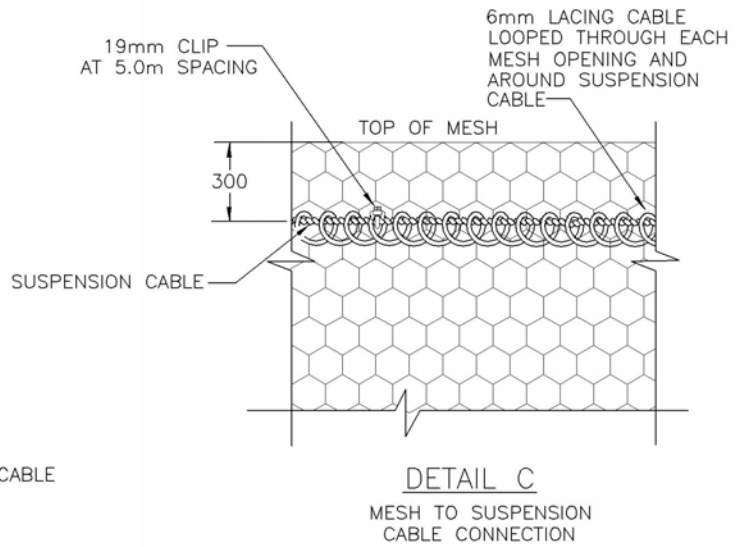
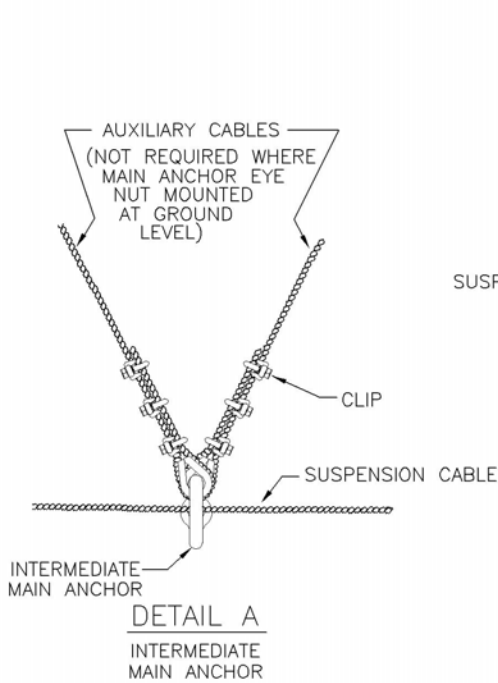

TABLE 1: CLIPS

CABLE TYPE	CABLE SIZE (mm)	CLIP SIZE (mm)	N°. OF CLIPS FOR LOOP	DIMENSION 'A' (mm)	TORQUE Nm (ft. lbs)
Suspension, End, Guy	19	19	4	460	175 (130)
Auxiliary	16	16	3	300	113 (95)
Lacing	6	19	(varies)	N/A	54 (45)

NOTES:

1. FOR LOCATION OF DETAILS SEE DWG. SP207-01.

NOT TO SCALE

ALL DIMENSIONS ARE IN MILLIMETRES UNLESS OTHERWISE NOTED

SLOPE MESH - DETAILS

SP207-04

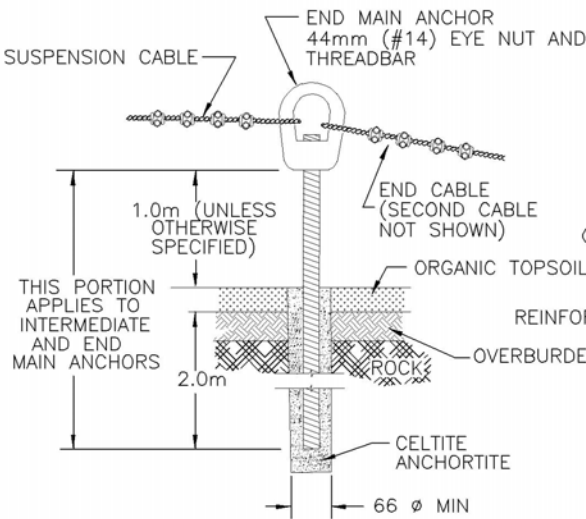

DETAIL D
END MAIN ANCHOR CONNECTIONS
(MESH OMITTED FOR CLARITY)

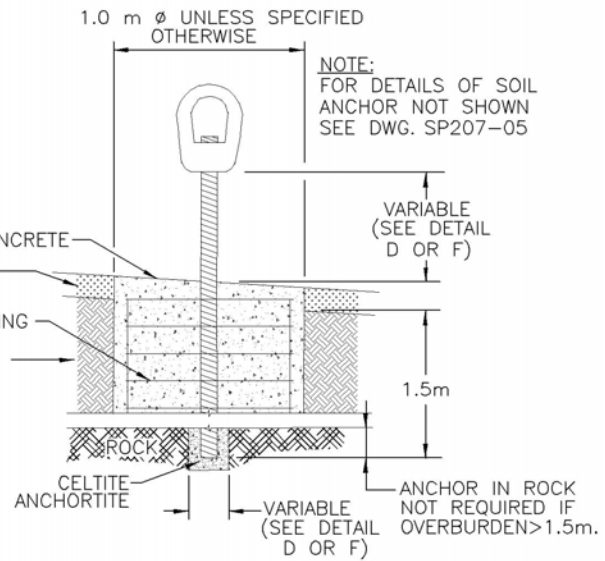

SOIL ANCHOR DETAIL
ALTERNATE ANCHOR DETAIL IN OVERBURDEN.
FOR OVERBURDEN THICKNESS GREATER
THAN 0.6m (SEE SUBSECTION 207.01.08)

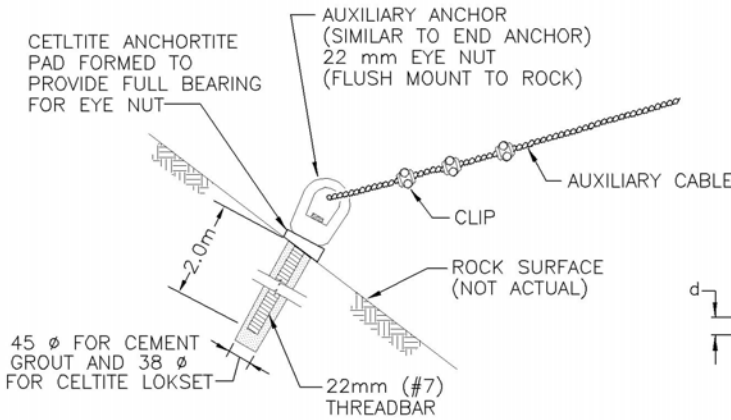

DETAIL F
AUXILIARY ANCHOR
CONNECTIONS

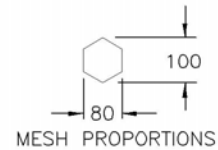

MESH OVERLAP:
FOR SPENAX HIGH TENSILE
11G-40 HOG RINGS USE
d = 50mm
FOR TIGER TITES USE
d = 80mm

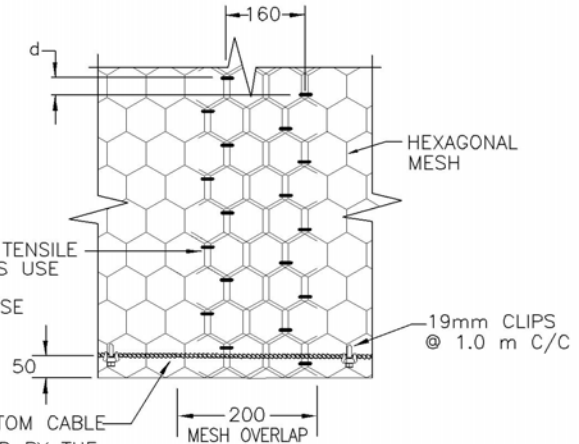

DETAIL E
MESH SEAM CONNECTIONS AND BOTTOM CABLE

NOTES:

1. FOR LOCATION OF DETAILS SEE DWGS. SP207-01 & 02.

NOT TO SCALE

ALL DIMENSIONS ARE IN MILLIMETRES UNLESS OTHERWISE NOTED

SOIL ANCHOR CONCRETE AND REINFORCEMENT FOR SLOPE MESH INSTALLATIONS

SP207-05

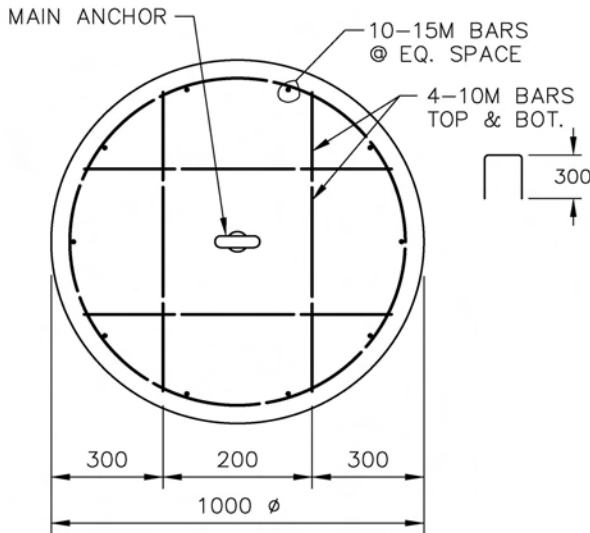

PLAN

NOTES:

1. INSTALL 300, 600 OR 1000mm ϕ SOIL ANCHOR AS SPECIFIED.
2. REDUCE SOIL ANCHOR DEPTH WHERE ROCK IS ENCOUNTERED, AND INSTALL MAIN ANCHOR INTO ROCK TO PROVIDE TOTAL 1.5m EMBEDDED LENGTH.
3. CONCRETE REQUIREMENTS SHOWN ON SLOPE MESH DRAWING.
4. ALL REINFORCING STEEL TO MEET C.S.A. SPECIFICATION G30.18-M, GRADE 400R.
5. ALL REINFORCING STEEL TO HAVE 50mm COVER UNLESS SPECIFIED OTHERWISE.
6. PLACE REINFORCING BARS IN ACCORDANCE WITH RECOMMENDED PRACTISES OF THE CONCRETE REINFORCING STEEL INSTITUTE (C.R.S.I.)
7. CONCRETE AND REINFORCING STEEL TO MEET STANDARD SPECIFICATION SECTIONS 412 AND 218 UNLESS SPECIFIED OTHERWISE.

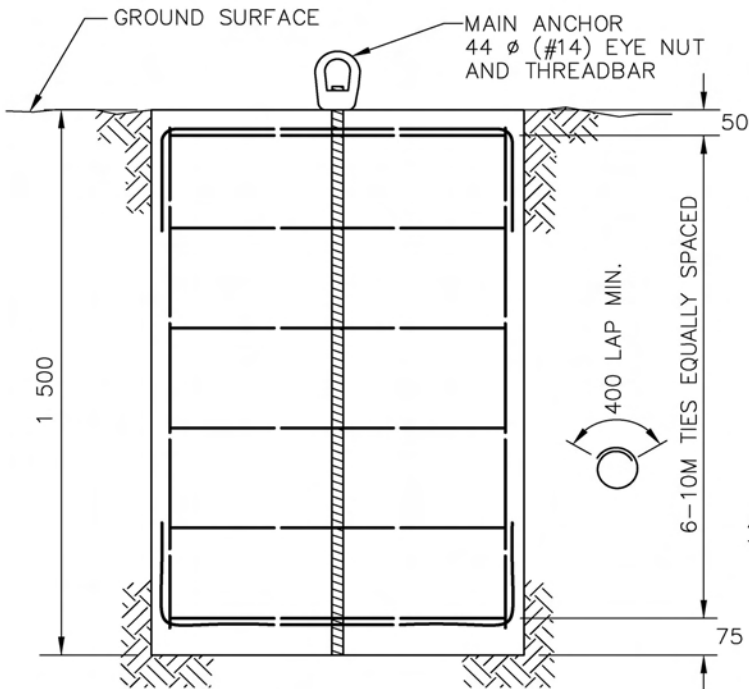

ELEVATION

1000 ϕ SOIL ANCHOR

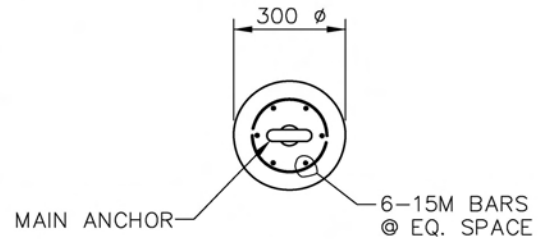

300 ϕ SOIL ANCHOR

(ALL NOT SHOWN SIMILAR TO 1000 ϕ SOIL ANCHOR)

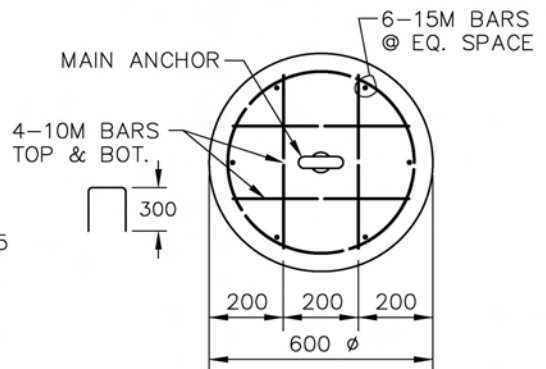

600 ϕ SOIL ANCHOR

(ALL NOT SHOWN SIMILAR TO 1000 ϕ SOIL ANCHOR)

NOT TO SCALE

ALL DIMENSIONS ARE IN MILLIMETRES UNLESS OTHERWISE NOTED

THIS PAGE IS LEFT INTENTIONALLY BLANK

SECTION 208

DRAINS FOR ROCK CUTS

DESCRIPTION

208.01 Scope – This Section covers the installation of lined drains in the designated areas to the specified depth. The exact locations of drain holes will be dependent on field conditions and will be detailed by the Ministry Representative.

MATERIALS

208.11 PVC Pipe Materials – Drain hole lining shall consist of Schedule 40 slotted PVC pipe. The outside diameter of the pipe shall not be less than 67% of the borehole diameter, and the internal diameter of the pipe shall be a minimum of 19 mm. The slots shall be along the entire length of the pipe in one row. Unless otherwise specified, the slots shall be 0.5 mm wide, spaced 6 mm apart and have a minimum length of 30% of the outside circumference of the pipe.

CONSTRUCTION

208.31 Drilling – Advancement of drilling for drain holes shall be in an upslope direction. The dip angle for drain holes shall be 5°, or as specified by the Ministry Representative. Finished holes shall be flushed with air to remove deleterious materials.

208.32 PVC Pipe Installation – PVC pipes shall be installed into the finished holes immediately after flushing. Pipes shall be coupled according to the manufacturer's specifications. The pipe shall be installed along the entire length of the holes and shall protrude 0.30 m out of the rock face. The slots shall be on top when the pipe is installed. The pipe shall be secured in the hole, using plastic or wooden wedges driven into the hole collar if necessary, so that the pipe cannot be pulled out by hand.

MEASUREMENT

208.81 Lined Drains – Lined drains will be measured by the METRE of drain hole drilled.

PAYMENT

208.91 Lined Drains – Payment for LINED DRAINS will be at the Contract Unit Price per metre. Payment for lined drains will be authorized after installation to the contract specifications. The Unit Price will be considered full compensation for all work and materials necessary to complete the installation prescribed in this Section.

THIS PAGE IS LEFT INTENTIONALLY BLANK

SECTION 209

SHOTCRETE FOR ROCK CUTS

DESCRIPTION

209.01 General – Unless otherwise specified, the shotcrete standards of ACI 506.2 and the standards of good practice in ACI 506R shall apply. SS 211, Portland Cement Concrete, shall also apply for shotcrete, unless otherwise specified.

Shotcrete operations shall include, but not be limited to pre-construction and construction work including preparation of the mix design(s), quality control, surface preparation; installation of wick drains, weep holes and pipes; supply and installation of the shotcrete; preconstruction and construction testing, curing; the supply, transportation and testing of shotcrete panels; any core extraction of the in-place shotcrete, and any other testing to determine curing or protection requirements.

209.02 Quality Control

209.02.01 General – The Contractor shall engage at its own expense, a specialist firm (the Contractor's Consultant) to provide on-site quality control for shotcrete operations. The Contractor's Consultant shall not be an employee of the Contractor.

209.02.02 Qualifications – The Contractor's Consultant shall have designed shotcrete for 3 projects over the last 5 years. The Contractor's Consultant's representative conducting onsite shotcrete tests shall be an ACI or CSA certified concrete technician.

209.02.03 Specific Requirements – For wet and dry process shotcrete, quality control shall include, but not be limited to the following:

- Observation of surface preparation before shotcrete application.
- Observation and testing during shotcrete application.
- Observation of curing operations.

209.02.04 Other Requirements – The Contractor's Consultant shall be present at other times as are appropriate to assist the Contractor in the preparation, assessment and adjustment of the various procedures to be used for shotcrete operations.

209.02.05 Field Report – The Contractor shall ensure that the Contractor's Consultant prepares a field report for each site visit, signed by the Contractor's Consultant. The report shall include details of the progress of shotcrete operations, any recommendations made to the Contractor and any problems encountered by the Contractor.

209.03 Submittals

209.03.01 The Contractor shall submit for review the following documentation by the pre-construction meeting:

a) Qualifications and Experience of the Contractor – Provide a statement of the qualifications, experience and work function of all personnel assigned to shotcrete duties. A statement of previous work experience on similar projects shall also be provided. This statement shall include the project name, location, type of shotcrete, volume of shotcrete, year constructed and the owner contact name. The company, the nozzle operator and the predampener/pot operator shall each have a minimum of 5 years demonstrated experience on shotcrete work.

b) Qualifications and Experience of the Contractor's Consultant – The qualifications shall include the name of the consulting firm, and the name and qualifications of the Consultant's on-site representative who will be providing the quality control. The following information shall be included in the qualifications submitted:

- Project name, location and experience.
- Name and phone number of the owner contact who can verify the experience of the Contractor's Consultant's site representative.

c) Proposed Laboratory Testing Agency – Provide a statement of the testing agency's experience in performing laboratory tests on shotcrete. The agency shall be an independent, qualified laboratory with a proven record of performing tests on shotcrete on at least 5 previous projects. The testing agency shall be certified to CSA A283.

d) Certification of the Concrete Technician – Provide evidence of ACI or CSA Certification for the concrete technician who will be providing on site shotcrete tests.

209.03.02 The Contractor shall submit for review the following documentation at least 10 days prior to commencing shotcrete operations:

a) Materials Records – Provide records showing source and proof of conformance to project specifications of the following materials:

- Portland Cement (provide mill certificates)
- Silica Fume (provide mill certificates)
- Mix Water
- Aggregates
- Admixtures (provide supplier data sheets)
- Fibre Reinforcement (if specified), include load/deflection curves to ASTM C 1018 for the proposed mix design
- Mesh Reinforcement (if specified, provide mill certificates)

b) Previous Performance Data – Provide previous

SECTION 209

SHOTCRETE FOR ROCK CUTS

performance data for the proposed shotcrete mix design, if available.

c) Proposed Shotcrete Mix Design (Proportions) – Provide documentation for the proposed shotcrete mix design. Include such back-up data as requested. The proposed mix design submittal shall include:

- Mix design number.
- Batch quantities in kg/m³ based on aggregates in an SSD (Saturated Surface Dry) moisture state for wet process shotcrete and ready mix supplied dry process shotcrete. Batch quantities for dry bagged supply shall be based on mass of aggregates in a dry state.
- A total cementitious content of not less than 20% by mass of the total ingredients.
- Aggregate source, bulk density, absorption, combined gradation data and a grain size distribution graph scaled between 0.075 mm and 75 mm showing the percent passing curve for the combined aggregate.

d) Proposed Shotcrete Imprint – Provide a drawing of the proposed shotcrete imprint including content, imprinting method and materials that will be used to produce the imprint.

209.03.03 The Contractor shall submit for review the following documentation within 1 day following each day of shotcrete application:

a) Field Report – Provide original field reports signed by the Contractor's Consultant.

b) Daily Records – Provide daily shotcrete records with the following information (certified by the Contractor's Consultant in the case of wet process shotcrete):

- Contractor Name
- Nozzleman Name
- Helper Name
- Contractor's Consultant's Name (for wet process shotcrete)
- Contractor's Consultant's Representatives Name (for wet process shotcrete)
- Date
- Weather
- Contractor's start and end time
- Shotcrete equipment type
- Temperature
- Type of shotcrete (wet or dry process)
- When is slump measured, before or after admixture and fibres

Submit the following information for each batch of shotcrete:

- Batch number
- Location of shotcrete
- Mix design number
- Batch time at plant (wet process)
- Batch arrival time on site
- Truck departure time (wet process)
- Placement start time
- Placement end time
- Quantity used
- Water/cementitious materials ratio (wet process)
- As-shot air content (wet process)
- Slump (wet process) – indicate when measurement is made (e.g.: after air entrainment is added, before superplasticizer is added and before fibre reinforcement is added)
- Percent rebound (visual estimate)
- Average thickness of shotcrete
- Test panel number
- Shotcrete delivery tickets from batch plant (wet process)
- Comments on the quality of the shotcrete and any problems that arise
- Proposed revised mix design

209.03.04 The Contractor shall submit the laboratory test results within 2 working days after testing. These test results shall compare the shotcrete performance with the requirements given in Table 209-A. Records shall include all reporting requirements outlined for construction testing. Records shall also include an original summary report of all test results, showing the sample number, sample origin, panel number, panel origin, date the panel was sprayed, panel shipping date, date panel received at the laboratory, photos of prepared test samples, test date, sample age at testing, test results for each sample, average test results of the three samples for each test at a given age, and acceptability of the results.

209.04 Definitions – The following definitions refer to words and terms used in this specification. For definitions not covered in this document, refer to ACI 506R and ACI 506.2.

209.04.01 Blow pipe – Air / water jet operated by nozzle operator's helper during shotcrete placement to assist in keeping rebound and overspray out of the work.

209.04.02 Dry Process Shotcrete – A process where most of the water added to the shotcrete mixture is added at the nozzle.

209.04.03 Overspray – Shotcrete material deposited

SECTION 209

SHOTCRETE FOR ROCK CUTS

away from the intended receiving surface.

209.04.04 Pot (Sometimes called Gun) – Machine used to meter the shotcrete into the hose.

209.04.05 Predampener – Device used to mix a portion of the mixing water with the shotcrete. Can also be used to mix accelerator with shotcrete.

209.04.06 Saturated Surface Dry – The state of a material in which it will neither add nor subtract moisture from other material placed in contact with it.

209.04.07 Slake – A process of deterioration of freshly exposed rock due to exposure to the atmosphere and/or water.

209.04.08 Sloughing (also called sagging) – Subsidence of shotcrete, due generally to excessive water in the mix or placing too great a thickness of shotcrete in a single pass.

209.04.09 Weep Pipes – Plastic pipes inserted in water bearing fissures to relieve water pressure from behind the shotcrete.

209.04.10 Wet Process Shotcrete – Shotcrete in which all of the ingredients are mixed before introduction into the delivery hose. Compressed air is introduced to the material flow at the nozzle. If an accelerator is used, it is normally added at the nozzle.

MATERIALS

209.11 Materials

209.11.01 Cement – Cement shall be Type GU or HE.

209.11.02 Silica Fume – Silica fume shall meet the requirements of CAN/CSA-A23.5-M, Supplementary Cementing Materials, Type U Silica Fume, with the following additional requirements:

- Minimum SiO₂ content – 90 percent by mass

- Maximum carbon content: 5 percent by mass

209.11.03 Pozzolan – Pozzolan shall be Type F flyash.

209.11.04 Water – Surface or ground water may be used for cleaning the slope and curing provided it is free of deleterious substances. Verification that the water intended for use is acceptable is at the discretion of the Ministry Representative and at the expense of the Contractor.

209.11.05 Aggregates – Aggregate shall be normal density. The combined aggregate gradation limits shall meet the limits shown in Table 209-B.

209.11.06 Admixtures

a) General – Chemical admixtures shall include air-entraining, water reducing and set retarding admixtures where appropriate.

b) Superplasticizers – Superplasticizers shall meet the requirements of CAN3-A266.6-M.

c) Accelerating Admixtures in General – Accelerating admixtures shall only be used with the written consent of the Ministry Representative.

d) Accelerating Admixture Requirements – Accelerating admixtures:

- i)** shall be non-chloride based accelerating admixtures meeting the requirements of CAN/CSA A23.1M Clause 15.1.7.1;
- ii)** shall be compatible with the cement being used when tested in accordance with ASTM C 1117;
- iii)** shall have a demonstrated ability, when used at the required proportions, to produce accelerated shotcrete meeting the performance criteria specified in Table 209-A;
- iv)** for wet process shotcrete shall be liquid, dispensed at the nozzle in closely controlled quantities;

TABLE 209-A SHOTCRETE PERFORMANCE REQUIREMENTS

TEST DESCRIPTION	TEST METHOD	AGE (DAYS)	SPECIFIED REQUIREMENT
*Maximum Water / Cementitious Materials Ratio		-	0.45
*Air Content – As Shot, %	CAN/CSA A23.2-4C	-	4 ± 1½
*Slump at discharge into shotcrete pump, mm	CAN/CSA A23.2-5C	-	80 ± 30
Minimum Compressive Strength, MPa	CAN/CSA A23.2-14C	7 28	30 40
Minimum Flexural Strength, MPa	ASTM C 1018	7	4
Minimum Toughness Performance Level (TPL)	ASTM C 1018 and this specification	7	III
Maximum Boiled Absorption, %	ASTM C 642	7	8
Maximum Volume of Permeable Voids, %		7	17

Notes: * Properties apply to wet process shotcrete only.

SECTION 209

SHOTCRETE FOR ROCK CUTS

v) for dry process shotcrete shall be liquid, dispensed at the nozzle in closely controlled quantities; or be powdered and either:

- integrally mixed in the case of dry bagged material or;
- mechanically proportioned through the predampener in the case of ready mix supply; metering of accelerators directly into the pot will not be permitted.

209.11.07 Fibre Reinforcement – Unless otherwise specified, shotcrete reinforcement shall consist of steel or polyolefin fibres. The fibres shall be capable of meeting the performance criteria specified in Table 209-A and the following requirements:

- a) **Steel Fibres** – These fibres shall meet the requirements of ASTM C 1116 Type I.
- b) **Polyolefin Fibres** – These fibres shall only be used in wet process shotcrete and shall meet the requirements of ASTM C 1116 Type III.

209.11.08 Mesh Reinforcement – Where specified instead of or in addition to fibre reinforcement, shotcrete shall be reinforced with mesh anchored to the surface before shotcrete application. For fibre reinforced shotcrete, additional reinforcement may be required by

TABLE 209-B COMBINED GRADATION LIMITS FOR SHOTCRETE AGGREGATE

U.S. STD SQUARE MESH	METRIC SIEVE SIZE	TOTAL PASSING EACH SIEVE SIZE, % BY MASS
3/4	20 mm	
1/2	14 mm	100
3/8	10 mm	90-100
#4	5 mm	70-85
#8	2.5 mm	50-70
#16	1.25 mm	35-55
#30	0.630 mm	20-35
#50	0.315 mm	8-20
#100	0.160 mm	2-10

placing mesh panels up to 0.60 m by 0.60 m without anchors between successive shotcrete lifts where final shotcrete thicknesses are expected to exceed 300 mm in local areas.

- a) **Mesh Materials** – Mesh shall consist of welded wire fabric 102 mm by 102 mm opening (4 by 4 inch) by MW13.3 / MW13.3 (8 gauge) wire meeting CSA G30.5 and hot dip galvanized meeting ASTM A 123.
- b) **Mesh Anchor Materials** – Anchors shall consist of ASTM A 615 Grade 400 steel, minimum 19 mm nominal diameter. Anchorage may be resin or grout. Grout anchorage may be Ocean "Microsil Anchor Grout" or Target "Unsanded Silica Fume Grout". Resin anchorage may be Celtite Lokset or Ground Control cartridges. Face

plates shall be 150 mm by 150 mm by 6 mm. Face plates, nuts and washers shall be capable of developing full anchor pullout capacity.

- c) **Mesh Coverage and Overlap** – Mesh shall be installed over the entire area to be shotcreted, unless otherwise specified. Mesh joints shall be lapped 1.5 mesh openings in each direction (horizontally and vertically) and tied at minimum 100 mm intervals with 16 gauge tie wire to achieve full contact between mesh layers.
- d) **Mesh Anchor Spacing** – Mesh shall be anchored on minimum 1.2 m centres in each direction or closer where required to form the mesh to within 50 mm of the slope surface. The mesh shall be in full contact with the surface where practicable. The mesh may also be anchored to any previously installed rock bolts provided the spacing is consistent with the spacing required for the above anchors.
- e) **Anchor Installation** – Anchors shall be installed as recommended by the anchor manufacturer. The minimum anchor embedment length shall be 1.0 m. Resin or grout shall be applied to full anchor embedment.
- f) **Mesh Anchor Testing** – A total of 5% of the anchors shall be load tested to 20 kN. This load shall be held for 10 minutes. A load loss of greater than 10% of the applied load shall be indicative of anchorage failure. Any failed anchors shall be replaced at the Contractor's expense.

209.11.09 Anchor Reinforcement – Where specified, additional anchor reinforcement shall be installed. Anchor materials, installation and testing shall meet the requirements for mesh anchors unless otherwise specified. Face plates for these anchors shall be "Spider Plates". These anchors and plates shall be fully embedded in the shotcrete.

209.11.10 Materials Handling and Storage

- a) **General** – All materials shall be stored and handled in a manner that will prevent damage, deterioration or contamination.
- b) **Hot Weather Storage** – During hot weather prebagged material shall be stored in a manner that will allow maximum cooling of the material.
- c) **Cold Weather Storage** – During cold weather prebagged material shall be stored in a manner that will provide maximum heat retention of the material.

209.12 Performance Requirements

- 209.12.01 General** – Shotcrete shall meet the performance requirements in Table 209-A.
- 209.12.02 Air Content** – The air content shall be determined on wet process shotcrete sprayed into a CAN/CSA-A23.2-4C air pressure meter base or freshly applied material removed from in-place and consolidated into the air meter base by rodding.

CONSTRUCTION**209.31 Batching, Mixing and Conveyance**

209.31.01 General – Shotcrete shall be batched, mixed and supplied using (one of) the following system(s):

- a) dry bagged pre mix supply to ASTM C 928 or:
- b) ready mix supply

209.31.02 Mixing – Shotcrete supplied shall be uniformly mixed with no evidence of segregation or improper mixing.

209.31.03 Batching and Conveyance – Ready mix supplied shotcrete shall be batched and conveyed at a rate that allows a consistent application of shotcrete. Irregularities of conveyance that result in delays or a surplus of aged material on site shall be avoided. Shotcrete that has stiffened excessively or is more than 90 minutes old from the time of batching will not be accepted.

209.32 Preconstruction Testing

209.32.01 General – The Contractor shall perform preconstruction shotcrete tests (prior to full-scale shotcrete operations), at a shotcrete test site chosen by the Ministry Representative, to demonstrate the competence of the crew, the adequacy of the equipment and the adequacy of the shotcrete mix design. The requirement for preconstruction testing may be waived by the Ministry Representative if sufficient documentation of previous satisfactory performance on similar work is provided.

209.32.02 Previous Performance – Documentation for previous satisfactory performance shall meet the following requirements:

- a) **Company** – The company shall have applied more than 100 m³ of shotcrete on a minimum of 3 projects in the last 5 years.
- b) **Nozzle Operator** – The nozzle operator shall have applied more than 100 m³ of shotcrete on a minimum of 3 projects in the last 5 years.
- c) **Predampener/Pot Operator** – The predampener/pot operator shall have mixed more than 100 m³ of shotcrete on a minimum of 3 projects in the last 5 years.
- d) **Contacts** – The contact name and number for each project above shall be supplied upon request.

209.32.03 Application – Shotcrete applied at the shotcrete test site shall be applied in accordance with the general shotcrete provisions in these specifications.

209.32.04 Test Panel – One test panel shall be gunned and tested for the preconstruction shotcrete testing as described for construction testing.

209.32.05 Test Results – The Contractor shall not apply shotcrete outside of the shotcrete test site area until the preconstruction shotcrete test results have been evaluated by the Ministry Representative and authorization is given

to proceed with the work.

209.32.06 Revised Methods – If the results of the shotcrete tests are unsatisfactory in the opinion of the Ministry Representative, then, notwithstanding the Ministry Representative's prior review of the Contractor's preconstruction submittals, the Contractor shall adopt such revised methods as are necessary to achieve the required results.

209.32.07 Additional Tests – The Contractor shall perform, at any time during the progress of the work, additional shotcrete tests at designated test sites if the shotcrete applied in the areas specified in this Contract is unsatisfactory in the opinion of the Ministry Representative.

209.33 Weather Conditions

209.33.01 Heavy Rain or High Wind – During periods of heavy rain or high wind, the Contractor shall ensure that the quality of the finished shotcrete product is not compromised. Shotcrete shall not be applied during such weather unless protective measures can be practicably taken.

209.33.02 Hot Weather – During periods of hot weather, when ambient temperatures are expected to rise over 30°C, the following requirements shall be met:

- a) **Curing** – The Contractor shall implement curing immediately after the shotcrete has been placed.
- b) **Temperature at Placement** – The Contractor shall take any steps necessary to ensure that the temperature of the shotcrete supplied to the site is less than 25°C at the time of placement.

209.33.03 Cold Weather – During periods of cold weather, where the minimum ambient air temperature falls below 5°C, the following requirements shall be met:

- a) **Temperature at Placement** – The Contractor shall take whatever steps are necessary to ensure that the in-place shotcrete temperature is between 10 and 25°C at the time of placement.
- b) **Initial Curing Temperature** – The Contractor shall ensure that, during the initial curing period (4 days), the in-place shotcrete temperature will not fall below 5°C. Shotcrete shall not be placed unless measures can be practicably taken to ensure these requirements are met.

c) **Temperature at the Pot** – The Contractor shall not allow the temperature of the dampened dry process shotcrete at the pot to exceed 30°C.

d) **Ice, Snow or Frozen Surfaces** – Shotcrete shall not be applied to frozen surfaces, or surfaces covered with frost, ice or snow.

209.34 Surface Preparation – Surfaces to which shotcrete is applied shall be cleaned of loose rock, dirt and debris which if left in place could impair the bond of

shotcrete to rock, concrete or existing shotcrete. Water or air and water jets shall be used to clean rock surfaces. Compressed air only shall be used to clean rock surfaces that have a tendency to slake from contact with water.

209.35 Drainage – Unless otherwise controlled, water seepage from slopes shall be controlled by installing weep holes, weep pipes, and wick drains. Surface runoff shall be controlled using suitable water diversion systems.

209.35.01 Weep Holes – Weep holes (and weep pipes as required) shall be installed before shotcrete is applied. These weep holes shall be on 1 to 1.5 m centres in the areas to be shotcreted in joints, fractures and faults, or at a closer spacing where required by the Ministry Representative. Holes and pipes shall be inclined to permit free drainage.

209.35.02 Weep Pipes – To prevent blockage of weep holes due to entry of shotcrete or rebound materials, weep pipes shall be secured in weep holes and temporarily plugged at the outer end of the pipe. The plugs shall be removed when shotcreting is completed. Weep pipes shall consist of 25 mm minimum outside diameter Schedule 40 plastic pipe.

209.35.03 Active Seepage Areas – Where active seepage occurs, weep holes shall be drilled approximately 150 mm or more to intercept fractures or openings wherever practicable and weep pipes shall be installed prior to the application of shotcrete. Where drilling is not practicable, the weep pipes shall be secured in the fractures by other appropriate means.

209.35.04 No Active Seepage Areas – Where no active seepage occurs, weep holes shall be installed in joints, fractures and faults by one of the following methods:

- a) by securing the weep pipes by appropriate means before shotcreting;
- b) by marking locations using sticks or other appropriate means before or during shotcreting and drilling at the marked locations after shotcreting. Weep holes shall be 25 mm diameter and shall be drilled to intersect the joints, fractures and faults under the shotcrete at the marked locations. Weep pipes are not required for such holes.

209.35.05 Weep Pipe Removal or Cutting – Weep pipes shall be removed or cut level with the shotcrete surface after the shotcrete has reached initial set, within one day after application.

209.35.06 Additional Weep Holes – Additional weep holes shall be drilled after shotcreting where there are visible signs of water pressure, such as seepage and damp spots in the hardened shotcrete.

209.35.07 Wick Drains – In areas of active seepage, wick drains shall be installed before shotcreting in addition to weep holes if requested by the Ministry Representative. Wick drains shall consist of a flexible polypropylene core

drain wrapped with a proven durable geotextile filter fabric. Wick drains shall be 3 mm by 100 mm size (variable length), with #120 sieve filter, 0.17 mm/s filter permeability, and 0.8 kN core grab tensile strength. They shall be able to withstand all handling, abrasion and distortion that occur during installation. Wick drains shall be secured to the surface on maximum 0.5 m centres with pneumatically driven nails, or authorized substitute fasteners. Fastener spacing shall be reduced where required to ensure wick drains are in full contact with the surface. Wick drains shall be installed and covered with shotcrete in a manner that allows gravity drainage to the toe of the slope.

209.35.08 Surface Runoff – Where the bond of shotcrete to rock may be impaired by surface water runoff, this water shall be controlled and directed away from the area to be shotcreted.

209.36 Existing Rock Bolts – Within or near areas designated for shotcrete where rock bolts were installed (not for the sole purpose of securing mesh) prior to shotcrete application, the rock bolts shall be protected or extended through the shotcrete as follows:

209.36.01 Extension of Rock Bolts – Unless otherwise specified, where rock is fractured within 0.5 m of the existing rock bolts, the face plates and nuts shall be removed before shotcrete is applied. The bar shall be extended, where necessary, using a short piece of bar and a coupler. The shotcrete shall be applied up to and against the existing bar. The face plates and nuts shall then be reinstalled over the shotcrete after the shotcrete has cured. Each face plate shall be replaced to the same bar from which it was removed. The exposed bar length shall be 100 mm following reinstallation of the face plate. The bar shall be nominally tensioned (using a wrench to the nut).

209.36.02 Protection of Rock Bolts – All other rock bolts shall be protected from overspray. Where overspray was not anticipated, the affected rock bolts shall be cleaned off by appropriate means.

209.37 Application

209.37.01 General – Prior to application of any shotcrete, the Contractor shall obtain authorization to proceed after the areas prepared for shotcrete have been reviewed by the Ministry Representative. Review by the Ministry Representative shall not relieve the Contractor from the responsibility for ensuring that the shotcrete operations are conducted in a satisfactory manner in accordance with these specifications.

209.37.02 Wetted Surface – Not more than one hour prior to application of shotcrete, all surfaces (except slaking ground) to be shotcreted shall be sprayed with water. Wetted surfaces shall be allowed to dry back to a saturated-surface-dry condition prior to application of shotcrete. If necessary, a blow-pipe shall be used to facilitate removal of surface water. Compressed air used

in the blow pipe shall be oil-free.

209.37.03 Shotcrete Layers – Wherever possible, shotcrete shall be applied to the full thickness in a single layer, provided it does not slough or become delaminated. If multiple lifts are required, the previous shotcrete lifts shall be scraped or broomed prior to the time of set to remove any loose material, rebound, overspray, laitance or any other material that may impair bond of subsequent layers. Previous lifts shall be prevented from drying out by moist curing. Construction joints shall be to a 45° edge.

209.37.04 Rebound and Overspray – A blow pipe shall be used during the course of the work to remove accumulations of rebound and overspray from areas to be shotcreted. Rebound and overspray shall not be incorporated in the completed work.

209.37.05 Thickness and Area Covered – In general, an average thickness of 100 mm of shotcrete shall be applied over fractures, joints and faults in the areas designated for shotcrete, unless otherwise specified by the Ministry Representative. In general, shotcrete shall cover laterally to a maximum of 0.50 m beyond fractures, joints and faults over solid rock or concrete areas.

209.37.06 Access – Suitable devices shall be employed to allow access to the work for shotcreting. Access shall be such that fresh shotcrete is not damaged by hoses, equipment or personnel.

209.37.07 Surface Finish – The shotcrete surface shall be left in a natural gun state unless otherwise specified.

209.37.08 Embedments – A cover of 50 mm of shotcrete shall be applied over any reinforcing steel or other embedments. If greater total thicknesses of shotcrete are applied to encapsulate the embedments this work shall be performed at no cost to the Ministry.

209.37.09 Imprint – The plastic shotcrete surface shall be neatly imprinted with capitalized lettering 75 mm high with the following information:

- MoT
- (the shotcrete completion date, in the format MM, YYYY)
- (the name of the Contractor)

The imprint shall be located in a small area in the bottom right corner of each continuous shotcrete area, unless otherwise authorized by the Ministry Representative. Where practicable, the information shall be readable unaided from highway level following shotcrete curing. Imprints produced by scraping letters into the plastic shotcrete will not be acceptable.

209.38 Curing and Protection

209.38.01 Curing Compounds – Membrane curing compounds shall not be used unless specifically authorized

in writing by the Ministry Representative.

209.38.02 Moist Curing – The surface of the shotcrete shall be maintained in a moist condition for a minimum period of 4 days following shotcrete application or until an in-place compressive strength of 20 MPa has been reached. Wet burlap and polyethylene sheet or water sprays shall be used to provide moist curing.

209.38.03 Protection from Freezing – The shotcrete shall be protected from freezing for a minimum period of 7 days after placing or until an in-place compressive strength of 20 MPa has been reached, whichever occurs first.

209.38.04 Sampling and Testing – If compressive strength samples are used to determine curing or protection requirements, the cost for obtaining the samples, shipping the samples and performing the tests shall be the responsibility of the Contractor. Extraction of cores shall be in accordance with CAN/CSA A23.2-14C. Compressive strength testing shall be performed according to requirements for construction testing.

209.39 Construction Testing

209.39.01 On-Site Tests – For wet process shotcrete, the following on-site tests shall be conducted for each truck:

- As-placed air content.
- Slump at discharge into pump.

209.39.02 Thickness Monitoring – The Contractor shall monitor the thickness of shotcrete applied using depth gauges or probes. Thickness shall be measured on 1.0 m centres or closer as required to provide thickness control.

209.39.03 Test Panels in General – The Contractor shall produce test panels in accordance with the requirements of ASTM C 1140, but panels shall have minimum base dimensions of 500 mm x 500 mm and a minimum depth of 125 mm. The form base shall be made from 19 mm thick sealed plywood, and side pieces shall be made from two by six timbers. The test panel molds shall have 45° sloped sides to permit escape of rebound.

209.39.04 Test Panel Frequency – One construction test panel shall be cast on each day of shotcrete placement or for every 50 m³ of shotcrete being placed, whichever results in more panels. The time of gunning the panels may be chosen by the Ministry Representative.

209.39.05 Test Panel Gunning and Marking – Test panels shall be gunned using the same nozzle and length of hose as the production shotcrete. The Ministry may request test panels to be gunned at the location of the in-situ shotcrete. Construction test panels shall contain no reinforcement or embedments (other than fibre reinforcement). For each test panel the Contractor shall provide a record of the test panel number, date cast, date shipped and date received by the laboratory.

209.39.06 Test Panel Curing and Transportation –

Test panels shall be field cured, in the forms, in the same manner as the specified shotcrete work, for a minimum period of 48 hours, prior to transport to the test laboratory. Panels shall be covered with wet burlap and plastic sheet to prevent drying. In cold weather, panels shall be protected from temperatures below 5°C by covering with thermal insulation blankets or by placing panels in a suitably heated enclosure. Test panels shall be transported in their forms and kept moist, with care being taken not to crack or damage the shotcrete.

209.39.07 Test Panels in Laboratory – The test panels shall be placed in a moist room in the laboratory, maintained at a temperature of 23 ± 2°C and relative humidity of 98 ± 2%. After age 3 days the test panels shall be removed from the forms and returned to the moist room until the time of testing.

209.39.08 Test Specimen Extraction and Storing – At specified test ages, test specimens shall be extracted from the panels using either diamond sawing or coring. Test specimens shall be maintained in a moist state in the moist room in the laboratory or in a lime-saturated water bath maintained at 23 ± 2°C until the time of testing.

209.39.09 Compressive Strength Test Specimens – Compressive strength test specimens shall preferably be 75 mm diameter cores. Length/diameter ratios shall not exceed 2:1 and shall not be less than 1:1.

209.39.10 Compressive Strength Testing – For each panel, three specimens shall be tested for compressive strength at each specified age. Compressive strength tests shall be conducted in accordance with CSA/CAN-A23.2-14C. Measured compressive strengths shall be corrected to equivalent 2:1 length:diameter cores, using the core correction factors given in CSA/CAN-A23.2-14C (Table 1). Reporting of results shall be according to Section 5 (Reporting) in CSA/CAN-A23.2-14C.

209.39.11 Flexural Strength and Toughness Test Specimens – Flexural strength test specimens shall have dimensions of 100 mm x 100 mm x 350 mm. Reporting of results shall be according to "11. Report" in ASTM C 1018 and shall include all load – deflection graphs.

209.39.12 Flexural Strength and Toughness Testing – For each panel, three specimens shall be tested for flexural strength and toughness at the specified age. Flexural strength and toughness tests shall be conducted in accordance with ASTM C 1018 with the following additional requirements:

a) Measuring System – A "Japanese Yoke" or other measuring system that precludes any extraneous deflection measurements shall be used. An automatic data acquisition system or equivalent shall also be used during the tests.

b) Accuracy of Measurement – The accuracy of the first crack deflection shall be verified by comparing the

measured value with the theoretically calculated value by using the formula:

$$\delta = \frac{23 PL^3}{1296 EI} \times \left[1 + \frac{216 H^2 (1 + \mu)}{115 L^2} \right]$$

Where:

δ = mid-span deflection in mm

P = load at first crack in kN

L = load span in mm

E = modulus of elasticity (for convenience usually based on an estimated compression modulus of elasticity) in GPa

I = moment of inertia in mm⁴

H = height of specimen in mm

μ = Poisson's Ratio (for convenience usually based on an assumed compression Poisson's Ratio of 0.2)

For a 100x100x350 mm beam tested on a 300 mm span the first crack deflection for typical fibre reinforced shotcrete will have first crack deflection in the range of about 0.03 to 0.05 mm. Extraneous deflections have been eliminated if first crack deflections are within this range.

c) Recording of Deflections – An LVDT connected to an x-y plotter or digital recording shall be used to capture load vs. deflection response. Dial gauges shall not be used for recording deflections. Bending Load shall be plotted against Net Midspan Deflection.

d) Testing Machine – A deflection-control testing machine shall be used, but shall not be of the closed-loop or soft testing type.

e) Total Deflection – Deflection measurements shall continue until a total deflection of 2 mm is reached.

TABLE 209-C TOUGHNESS PERFORMANCE LEVEL

TOUGHNESS PERFORMANCE LEVEL	RESIDUAL FLEXURAL STRENGTH BY % OF DESIGN FLEXURAL STRENGTH	
	1/600 Span (0.5 mm)	1/150 Span (2.0 mm)
III	50%	30%

209.39.13 Toughness Performance Level Data Analysis – Toughness Performance Level of flexural strength specimens shall be obtained by the following analysis:

a) Template – A template shall be created using the percent of design flexural strength shown in Table 209-C, but expressed in load equivalent units. The following

formula shall be used:

$$P_d = \frac{\sigma \times B \times H^2}{L} \times \frac{1}{1000}$$

to determine load equivalent units, where:

P_d = design flexural load in kN

σ = design flexural strength in MPa

B = beam width in mm

H = beam depth in mm

L = load span in mm

b) Master Template – A master template shall be produced to the same scale as the load vs. deflection data recorded from the toughness test. The master template shall be superimposed over the actual load deflection curves and compared with the recorded data.

c) Acceptability Criterion – To conform to a given Toughness Performance Level the recorded data shall meet the specified flexural strength and fall above the line representing the given Toughness Performance Level at both the 0.5 mm and 2 mm net midspan deflection.

209.39.14 Boiled Absorption and Permeable Voids

Test Specimens – Specimens for boiled absorption and permeable voids testing shall be 75 mm cubes cut from the broken ends of flexural test prisms, or extracted 75 mm diameter cores at least 100 mm long.

209.39.15 Boiled Absorption and Permeable Voids

Testing – For each panel, three specimens shall be tested for boiled absorption and permeable voids at the specified age. Boiled absorption and permeable voids tests shall be conducted in accordance with ASTM C 642. The report of results shall include all information recorded for “6.1 Calculation” in ASTM C 642.

209.39.16 Laboratory Test Results – For each type of test, test results shall be considered acceptable if the average of three (3) specimens tested at a given age meets or exceeds the criteria specified in Table 209-A. The test results for an individual specimen shall not be less than 80% of the criteria specified for compressive strength, and not more than 120% of the criteria specified for boiled absorption and permeable voids.

209.40 Shotcrete Deficiencies and Repair

209.40.01 General – The Contractor shall, whenever possible, correct deficiencies while the shotcrete is still plastic. For any proposed changes to the initial mix design, a solid volume calculation shall be performed and submitted upon request. The calculation shall include the mass, density and volume of each constituent material, the total yield, and a comparison between measured (ASTM C 138) and the calculated plastic density.

209.40.02 Deficiency Types – Shotcrete deficiencies other than failure to meet the performance requirements include, but are not limited to, the following:

- a) Improper consolidation of the shotcrete because of incorrect spraying angles or improper distance of the nozzle from the receiving surface.
- b) Improper control and removal of overspray and rebound material.
- c) Excessive shotcrete or fibre rebound.
- d) Any evidence of excessive plastic or drying shrinkage cracking.
- e) Segregation, incorporation of sand lenses, excessive voids, tears, sags, sloughs or delaminations in the work.
- f) Inadequate thickness.

209.40.03 Shotcrete Repair – At the discretion of the Ministry, shotcrete with deficiencies as defined above shall be removed and replaced to these specifications.

209.41 Shotcrete Evaluation – The Ministry Representative will implement a program of evaluation of the in-place shotcrete.

209.41.01 Core Extraction – Cores shall be extracted from the in-place shotcrete in accordance with CAN/CSA A23.2-14C, at locations detailed by the Ministry Representative, and tested for compliance to the project specifications. Generally up to 6 cores shall be extracted from every 200 m² of shotcreted surface.

209.41.02 Non-Destructive Testing – The shotcrete will be checked for delaminations, voids or other deficiencies using appropriate non-destructive testing procedures.

MEASUREMENT

209.81 Shotcrete – Shotcrete will be measured by the CUBIC METRE supplied and installed in-place on the slope in the designated areas.

PAYMENT

209.91 Shotcrete – Payment for SHOTCRETE will be at the Contract Unit Price per cubic metre. Payment for up to 75% of the shotcrete installed will be authorized after the Ministry Representative has received 7 day test results for this shotcrete. Payment for the remaining 25% will be authorized after 28 day test results and complete documentation have been received. The Ministry may consider reduced payment for defective or deficient shotcrete based on test results on test panels and/or in-situ shotcrete. The Contract Unit Price for shotcrete shall be considered full compensation for all requirements in this specification.

DAILY SHOTCRETE RECORD

File #: _____

PROJECT NAME _____

PROJECT NO. _____

(TO BE SUBMITTED WITHIN 1 DAY AFTER EACH DAY'S OPERATION)

Contractor Name _____ Date _____

Nozzleman Name _____ Weather _____

Helper Name _____ Temperature _____ °C

Contractor's Consultant's Name _____ Contractor's Start _____ End _____ Time

Contractor's Consultant's Representative _____ Shotcrete Equipment Type _____

Shotcrete Type: (circle) WET DRY Process

For wet process, when is slump measured (circle) BEFORE AFTER Air entrainment added

BEFORE AFTER Superplasticizer added

BEFORE AFTER Fibre Reinforcement added

On-Site Details and Tests for Shotcrete:

Batch #	Location		Mix Design #	Batch Times:			Spray Start Time	Spray End Time	Quantity Used m ³	Water/Cement Ratio	Sample (As-Shot) Air Content	Slump (wet mix) (mm)	Re-bound est. (%)	Average Thickness of In-Place Shotcrete (mm)	Test Panel No.
	Zone	Area		From Plant	On Site From	To									

Comments: _____

Certified Correct: _____ (Contractor's Consultant's Representative) _____ (Title)

(Use Additional Sheets if Necessary)

SHOTCRETE TEST PANEL FORM

SP209-01

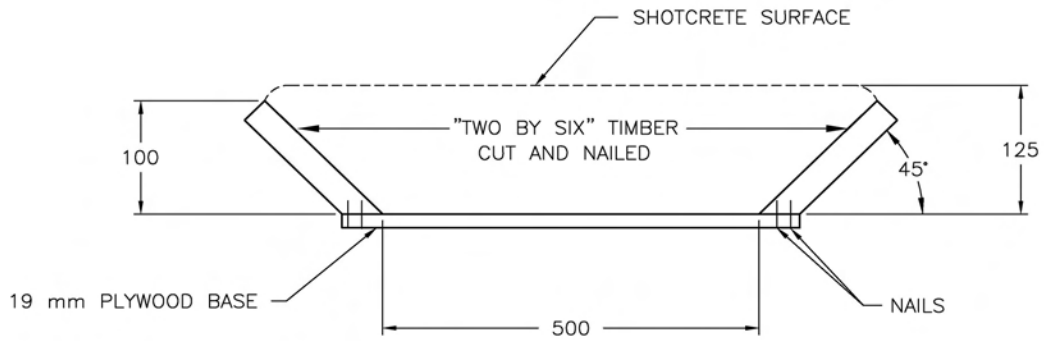

SECTION

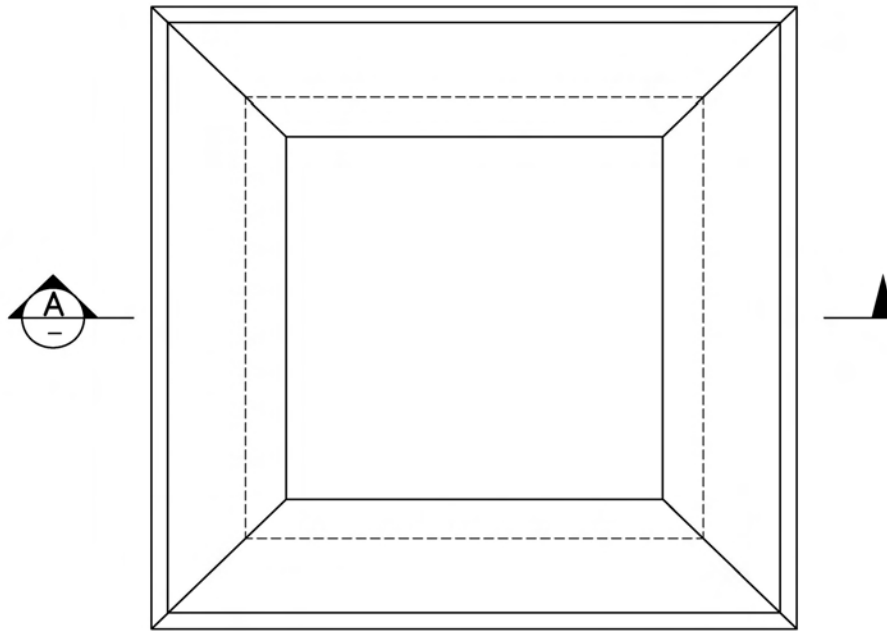

PLAN VIEW

NOT TO SCALE

ALL DIMENSIONS ARE IN MILLIMETRES UNLESS OTHERWISE NOTED

SHOTCRETE SPIDER PLATE DETAIL

SP209-02

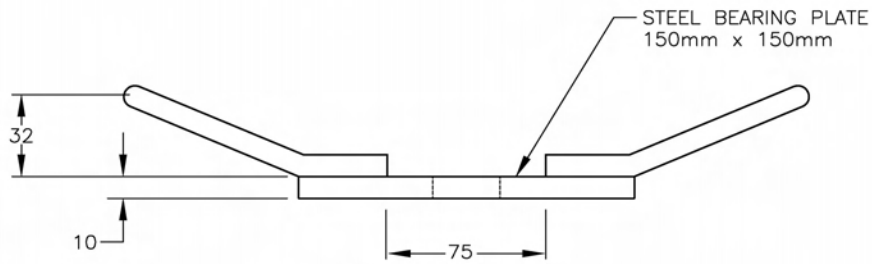

ELEVATION VIEW

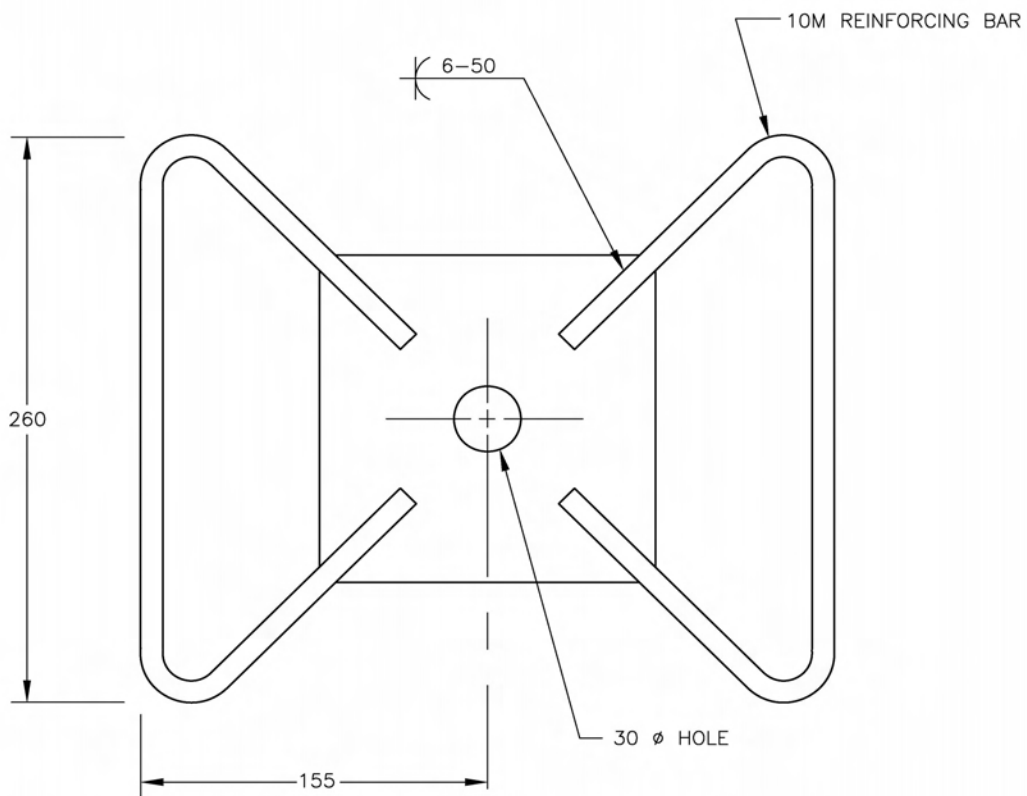

PLAN VIEW

NOT TO SCALE

ALL DIMENSIONS ARE IN MILLIMETRES UNLESS OTHERWISE NOTED

SECTION 211

PORTLAND CEMENT CONCRETE

211.01 General – This Section of the Province of British Columbia "Standard Specifications for Highway Construction" describes the requirements for Portland Cement Concrete. Requirements include quality control and quality assurance, constituent materials, mix design proportioning, sampling and testing of the materials and concrete, batching, mixing, transporting, placement, finishing and curing. The Contractor shall supply all necessary materials.

211.02 Applicable Standards – The standards listed in Table 211-A shall apply unless specified otherwise herein or in the Special Provisions. All referenced standards shall be to the current editions at time of tendering.

TABLE 211-A APPLICABLE STANDARDS

CAN/CSA-A23.1	Concrete materials and methods of concrete construction
CAN/CSA-A23.2	Methods of test and standard practices for concrete
CAN/CSA-A3000	Cementitious Materials Compendium
CAN/CSA-S269.3	Concrete Formwork
CAN/CSA-A283	Qualification Code for Concrete Testing Laboratories

211.03 Concrete Mix Designs and Submission Requirements

211.03.01 General – The Contractor shall be responsible for quality control of all components of the concrete operation, including but not limited to, aggregate and component quality, proportioning, test batching, batching, mixing, transporting, placing, consolidating, finishing, curing, and all necessary quality control and verification testing of the components and the fresh and hardened concrete.

211.03.02 Proportioning – The Contractor shall be responsible for proportioning and designing all concrete in full compliance with the stated mix specifications. All mix designs shall use the "Absolute-Volume Method" for mix proportioning.

211.03.03 Alkali-Aggregate Reactivity (AAR) Preventative Requirements – Contrary to CSA A23.2 27A, the total alkali content (Na₂O equivalent) contributed by the portland cement to the concrete mix shall not exceed 2.0 kg/m³. The Ministry reserves the right to alter this limit or to redefine the concrete

mix design parameters based on the review of the mix design submittal.

211.03.04 Mix Design Submittals – The Contractor shall submit a report outlining the proposed mix design for each classification of concrete to the Ministry Representative for review and acceptance at least 2 weeks in advance of when concrete production is scheduled to commence. Acceptance of the mix design by the Ministry does not constitute acceptance of the concrete. Acceptance of the concrete will be based on the test results and the performance and quality of the concrete and concrete components placed on the project. No concrete shall be placed prior to receiving Ministry acceptance of the mix design. Each mix design submittal shall include all of the following:

Project Specifics

- Name and location of the proposed supplier.
- Distance and expected travel time from batch plant location to project site.
- Expected method of batching, transporting and placing concrete.
- Specified mix parameter requirements.
- Name and contact information of certified quality control testing laboratory and certified testing personnel. Certification shall be in accordance with the requirements of CSA A23.1.

Materials

All materials shall comply with the requirements as listed in SS 211.04 of this Standard Specification.

- Cementitious Materials – Types and source of each material including mill test reports and manufacturer's certificates of compliance.
- Aggregates – Type and source of all individual aggregate products including individual gradations and all other aggregate quality testing as described in Table 211-D for each product and each aggregate source.
- Admixtures – Type and source of all admixtures, including expected dosage rates, point of addition to the mix, compatibility documentation, and individual technical data sheets.
- Water – The source of mixing water. (depending on the source, the MoT Representative may request additional test documentation).
- Miscellaneous – Documentation for all other materials proposed for the mix, showing

conformance with applicable Ministry requirements and manufacturer/industry guidelines and standards.

Proportioning

- The concrete proportions expressed in terms of quantity of each component.
- Fresh and hardened concrete properties.
- The mass of materials in kilograms (kg) and the absolute volume in cubic metre (m³) contributed by each material in the mixture.
- The quantity of each individual cementitious material added in a powder state shall be expressed as kilograms per cubic metre (kg/m³).
- Pozzolans that are added in slurry shall have their respective solid and water contents expressed as kilograms per cubic metre (kg/m³).
- The quantity of each separately batched size of coarse aggregate and fine aggregate shall be expressed as kilograms per cubic metre in a saturated-surface-dry (SSD) condition.
- The quantity of water shall be the maximum amount allowed based on the maximum specified water-to-cementitious material ratio (W/C_m), corrected to account for any additional water that may be contributed by other materials used in the proposed mix.
- The quantity of water shall be expressed as kilograms (or Litres) per cubic metre. If ice is used for temperature control, it shall be expressed in incremental units (sacks, bags, or pails, etc.) and kilograms per cubic metre and shall be included in the maximum allowable water quantity.
- Admixtures dispensed as liquids shall be expressed as Litres per cubic metre and where applicable, expected dosage range stated.
- The quantity of any pre-measured, pre-packaged additives, such as fibres, shall be expressed in incremental units (sacks, bags, or pails, etc.) and kilograms per cubic metre.
- The absolute volume of each material, air content and the total sum of the absolute volumes of all materials shall be provided in cubic metres (m³).
- Slump, unit weight, air content, strength characteristics, and any other specified characteristic shall be reported for each set of mixture proportions intended for use.

Incomplete submittals by the Contractor may result in rejection of the mix design submittal.

211.03.05 Trial Mixes – The Contractor shall produce test batches of 4.0 m³ volumes on all proposed bridge deck mix designs. The Contractor shall produce test batches of 4.0 m³ volumes on other mix designs where deemed necessary by the Ministry Representative. Point of discharge sampling and testing shall be carried out by the Contractor to verify the pertinent parameters of the proposed mix design. If placement

is by pump, concrete shall be sampled and fully tested at both the truck chute discharge and at the pump discharge locations. Sampling and testing shall be in accordance with SS 211.09, Table 211-J and Table 211-K. Test parameters include all required properties of the fresh and hardened concrete, workability and finishability of the mix, strength gain characteristics, including 7 and 28-day compressive strengths, and any other additional testing of the hardened concrete that may be required by the Ministry Representative. Batching, haul times and conveyance procedures used for the test batch must emulate the procedures expected during the actual concrete placement. The Contractor shall be fully responsible for all costs associated with the test batches. Test batch trials that do not meet the specified requirements shall be repeated.

211.03.06 Adjustments to Mix Designs – If, during the progress of the work, the mix design is found to be unsatisfactory, the Contractor shall make the necessary adjustments. Adjustments shall be accepted by the Ministry Representative prior to subsequent concrete placement. Notwithstanding the Ministry Representative's review and acceptance of the proposed mix design, it remains the Contractor's responsibility that the concrete meets all the specified requirements.

211.04 Materials

211.04.01 General – All material properties used in concrete production shall conform to CSA A23.1, unless otherwise specified in these specifications. Laboratory testing shall be carried out by a testing laboratory certified in accordance with the requirements of CSA Standard A283. Field test procedures shall be undertaken by personnel certified under an industry-recognized program.

211.04.02 Cementitious Material – The Contractor shall obtain, from the supplier, a mill test report and a manufacturer's certificate of compliance representing each type of cementitious material for each delivered shipment.

211.04.02.01 Portland Cement – Unless otherwise specified, the Contractor shall use Type GU (General Use) Portland Cement in all concrete. Cement shall conform to the requirements of CSA Standard A3000, Cementitious Materials Compendium.

The total alkali content [Na₂O equivalent, (Na₂O + (0.658 x K₂O))] of the Type GU Portland Cement shall not exceed 0.60% by mass.

211.04.02.02 Silica Fume – Dry condensed silica fume shall conform to CSA Standard A3000 Type SF, with a SiO₂ content of at least 85%, a maximum of 10% ignition loss, and maximum SO₃ content of 1.0%. Silica Fume application rates shall be 8%

SECTION 211

PORTLAND CEMENT CONCRETE

maximum by mass of Portland Cement.

211.04.02.03 Fly Ash – Fly ash shall conform to CSA Standard A3000, Type F or C1, with a maximum CaO content of 8%, a maximum SO₃ content of 5%, a maximum 8.0% ignition loss for Type F and a maximum 6% ignition loss for Type C1. Fly ash application rates shall be limited to a maximum of 25% by mass of Portland Cement in substructure concrete. Fly ash shall not be used in bridge deck concrete without the acceptance of the Ministry Representative. Upon such acceptance the maximum application rate shall be 15% by mass of Portland Cement.

211.04.02.04 Blended Hydraulic Cement – Blended Hydraulic Cement shall not be used without the acceptance of the Ministry Representative.

211.04.03 Water – Water to be used for mixing concrete or mortar and for curing shall conform to the requirements of CSA Standard A23.1 and shall be free from contamination by oil, acid, alkali, organic matter, sediment or other deleterious substances. The Contractor shall not use water from shallow, stagnant or marshy sources.

211.04.04 Admixtures – Admixtures shall not be incorporated into the mix design and/or added to the concrete without the acceptance of the Ministry Representative.

Unless otherwise specified, all concrete shall contain Air-Entraining Admixtures.

Air-Entraining Admixtures shall conform to ASTM C260.

Chemical admixtures shall conform to ASTM C494.

Type F High Range Water Reducer (superplasticizer) shall be used when concrete contains silica fume.

All accepted admixtures shall be compatible with all other admixtures and constituents used in the mix.

Type B, Retarding or Type D, Water-Reducing and Retarding (Hydration Stabilizing) Admixtures shall not be incorporated into the mix design and/or added to the concrete without the acceptance of the Ministry Representative. When accepted by the Ministry Representative, the guidelines given in SS 211.08.02 shall apply.

Calcium chloride or any admixture containing chloride ions shall not be used. If requested, a written statement from the manufacturer stating that the admixture contains no intentionally added calcium chloride shall be provided to the Ministry Representative.

211.04.05 Aggregates – All aggregates are to be natural, processed or manufactured granular material composed of hard, sound and durable particles, free of adherent coatings, shale, clay, organic materials and other soft or disintegrated pieces.

211.04.05.01 Coarse Aggregate – All coarse aggregate materials shall conform to the following requirements:

- Sampling shall be according to CSA Test Method

A23.2-1A.

- Gradation shall be determined in accordance with CSA Test Method A23.2-2A and 5A. (All gradations shall be based on a washed sieve analysis, see Table 211-D footnotes).
- Gradation of the coarse aggregate shall be within the limits shown in Table 211-B for the particular size range or nominal maximum size of coarse aggregate specified.
- **NOTE:** The gradation of coarse aggregates used shall be such that the percentage passing any one sieve does not vary more than 5% from the initially approved coarse aggregates used in the mix design.
- The maximum Petrographic Number (PN) of coarse aggregate shall not exceed 125, and shall be determined in accordance with CSA A23.2 15A.
- The amount of deleterious substances in coarse aggregate shall not exceed the limits prescribed in Table 211-E.

Other specified physical properties measuring aggregate quality referenced in Table 211-D shall not exceed the limits prescribed in Table 211-E.

211.04.05.02 Fine Aggregate – Fine aggregate shall conform to the following requirements:

- Sampling shall be according to CSA Test Method A23.2-1A.
- Grading shall be within the limits given in Table 211-C when tested in accordance with CSA Test Method A23.2-2A and 5A. (All gradations shall be based on a washed sieve analysis).
- Fineness modulus shall be between 2.3 and 3.1.
- Fineness modulus tolerance shall be ± 0.2 (except that the above sentence shall apply) from the fineness modulus of the initially approved fine aggregate used in the design mix.
- A maximum 45% shall be retained between any two consecutive sieves.
- The amount of deleterious substances in fine aggregate shall not exceed the limits prescribed in Table 211-E.
- Other specified physical properties measuring aggregate quality referenced in Table 211-D shall not exceed the limits prescribed in Table 211-E.

Table 211-B GRADATION REQUIREMENTS FOR COURSE AGGREGATES

NMS A ⁽¹⁾ mm	Product Size mm	Total Passing Each Sieve, Percentage by Mass								
		56 mm	40 mm	28 mm	20 mm	14 mm	10 mm	5 mm	2.5 mm	1.25 mm
40	40-5 ⁽²⁾	100	95-100	—	35-70	—	10-30	0-5	—	—
28	28-5 ⁽²⁾	—	100	95-100	63-83	30-65	—	0-10	0-5	—
20	20-5	—	—	100	90-100	50-90	25-60	0-10	0-5	—
14	14-5	—	—	—	100	90-100	45-75	0-15	0-5	—
10	10-2.5	—	—	—	—	100	85-100	10-30	0-10	0-5

(1) NMSA – nominal maximum size of course aggregate. Definition: The standard Sieve size opening immediately smaller than the smallest through which all of the aggregate must pass.

(2) To prevent segregation, aggregates that make up the above gradings shall stockpiled and batched in two or more separate sizes as per CSA A23.1

TABLE 211-C GRADATION REQUIREMENTS FOR FINE AGGREGATES

SIEVE SIZE mm	TOTAL CUMULATIVE PASSING EACH SIEVE, PERCENTAGE BY MASS	SIEVE SIZE mm	TOTAL CUMULATIVE PASSING EACH SIEVE, PERCENTAGE BY MASS
10	100	0.630	25-65
5	95-100	0.315	10-35
2.5	80-100	0.160	2-10
1.25	50-90		

211.04.06 Steel Fibres – Steel fibres shall meet the requirements of ASTM Standard A820 Type 1 Cold Drawn High Tensile Deformed Steel Fibres. A mill certificate showing compliance with ASTM Standard A820 shall accompany each delivered lot. Steel Fibres shall be Xerox 1 or Novotex or an alternate acceptable to the Ministry Representative.

Concrete where steel fibres are used shall contain 50 kg of 30 mm or 50 mm length fibres per cubic metre of concrete.

211.05 Storage and Handling of Materials - General – The storage and handling of all materials used in the production of concrete shall conform to CSA A23.1, unless otherwise specified herein. All materials shall be stored and handled in a manner that will prevent contamination or deterioration, otherwise they shall be rejected. Access shall be provided to the storage facilities to allow for inspection and sampling. Where applicable, materials shall be identified by MSD sheets.

211.05.01 Cementitious Material – All cementitious materials shall be stored in a suitable weather-tight structure capable of protecting the materials from dampness, hydration and contamination, otherwise they shall be rejected. Materials shall be free of lumps at all times during their use in the work and shall have a maximum temperature of 50°C.

211.05.02 Tanks – Tanks used for storing and/or hauling, concrete mixing and curing water shall be free from contamination by oil, acid, alkali, organic matter, sediment, rust or other deleterious substances.

211.05.03 Admixtures – All admixtures shall be stored in manufacturers' original labelled containers with clearly legible labels and be kept above freezing at all times and in accordance with the manufacturers' technical data sheets. Admixtures damaged by any cause shall be rejected.

TABLE 211-D REQUIRED AGGREGATE TESTING FOR NORMAL DENSITY COARSE AND FINE AGGREGATE (PER INDIVIDUAL PRODUCT & AGGREGATE SOURCE)

Test Method	Test Description	Test Data Validity ⁽⁵⁾
CSA A23.2-2A ⁽¹⁾ CSA A23.2-5A ⁽¹⁾	Sieve Analysis of Fine and Coarse Aggregate Amount of Material finer than 80 µm in Aggregate	Within 90 days ⁽⁶⁾ Within 90 days ⁽⁶⁾
CSA A23.2-3A	Clay Lumps in Natural Aggregate	Within 3 years
CSA A23.2-4A	Low Density Granular Material in Aggregate	Within 3 years
CSA A23.2-6A, 12A	Relative Density and Absorption of Fine and Coarse Aggregate	Within 1 year
CSA A23.2-7A	Test for Organic Impurities in Fine Aggregates for Concrete	Within 2 years
CSA A23.2-8A ⁽³⁾	Measuring Mortar-Strength Properties of Fine Aggregate	Within 2 years
CSA A23.2-9A ⁽²⁾	Soundness of Aggregate by Use of Magnesium Sulphate	Within 4 years
CSA A23.2-14A	Potential Expansivity of Aggregates (Procedure for Length Change Due to Alkali-Aggregate Reaction in Concrete Prisms)	Within 5 years
CSA A23.2-13A	Flat and Elongated Particles in Coarse Aggregate - Procedure A (Length to Width Ratio 4:1)	Within 3 years ⁽⁶⁾
CSA A23.2-16A ⁽⁷⁾	Resistance to Degradation of Small-Size Coarse Aggregate by Abrasion and Impact in the Los Angeles Machine	Within 4 years
CSA A23.2-23A ⁽²⁾	Test Method for the Resistance of Fine Aggregate to Degradation by Abrasion in the Micro-Deval Apparatus	Within 4 years
CSA A23.2-29A ⁽²⁾	Test Method for the Resistance of Coarse Aggregate to Degradation by Abrasion in the Micro-Deval Apparatus	Within 4 years
CSA A23.2-15A ⁽⁴⁾	Petrographic Analysis of Coarse & Fine Aggregate specific for use as concrete aggregate; and Determination of the Petrographic Number	See Note 4
CSA A23.2-15A ⁽⁸⁾	Test Method for the Resistance of Unconfined Coarse Aggregate to Freezing and Thawing	See Note 8

- (1) Each aggregate product that may be used as a component of the proposed mix must have a washed sieved analysis performed showing the cumulative percent passing for each of the following sieve sizes; 56, 40, 28, 20, 14, 10, 5, 2.5, 1.25, 0.630, 0.315, 0.160 and 0.080 mm. Sieve analysis reports are to include all relevant sampling information (date/sampled by/location/field sample size) and include the actual test specimen sample mass.
- (2) Subject to approval by the Ministry Representative, Test Method A23.2-9A can be performed as an alternative to performing Test Method A23.2-23A and A23.2-29A. Refer to CSA A23.1, Section 4.2, Table 12 for further information.
- (3) Test Method A23.2-8A is required only if the aggregate fails to meet the requirements of Test Method A23.2-7A as described in CSA A23.1 Section 4.2.3.3.3.2
- (4) **Petrographic Assessment of Aggregates:** The Contractor shall submit the results of the Petrographic Analysis, certified by a qualified professional registered with the Association of Professional Engineers and Geoscientists of B.C. and indicating the aggregate's suitability for its intended use. The petrographic analysis shall not be used to forfeit the requirement of performing other necessary aggregate quality testing.
- (5) Test data validity requirements are based on time periods prior to the expected initial date of concrete production. It is only applicable to aggregate sources proven to be materially consistent, based solely on historical test data. The Ministry Representative, based on submitted test data and/or visual observations, may reduce the above listed time periods.
- (6) Quality control during aggregate production shall include the following test methods at the specified test frequencies: CSA A23.2-2A & A23.2-5A (1 per 500 tonnes), and A23.2-13A (1 per 1000 tonnes).
- (7) Subject to approval by the Ministry Representative, Test Method CSA A23.2-16A can be waived if CSA A23.2-29A test results meet the specified criteria.
- (8) This test shall be required should any of Test Methods 4A, 9A, 16A or 29A fails to satisfy the allowable limits.

TABLE 211-E LIMITS FOR DELETERIOUS SUBSTANCES IN AND PHYSICAL PROPERTIES OF AGGREGATES

Test Method	Substance or Property	Maximum Percentage by Mass of Total Sample	
		Coarse Aggregate	Fine Aggregate
CSA A23.2-3A	Clay Lumps	0.25	1.0
CSA A23.2-4A	Low-Density Granular Materials	0.5	0.5
CSA A23.2-5A	Material Finer than 0.08 mm for Concrete Subject to Wear	1.0	3.0
	Material Finer than 0.08 mm for Other Concrete	1.0	5.0
CSA A23.2-9A	Magnesium Sulphate Soundness Loss	12	16
CSA A23.2-16A,	Los Angeles Abrasion Loss for Concrete Subject to Wear	<u>50</u> <u>(35)</u> <small>(All deck concrete)</small>	N/A
CSA A23.2-23A-29A	Micro-Deval Abrasion Loss	17	20
CSA A23.2-12A	Absorption Percentage	<u>1.75</u>	N/A
CSA A23.2-7A	Organic Impurities in Fine Aggregate	N/A	Standard colour or lighter ⁽¹⁾
CSA A23.2-13A	Flat and Elongated Particles in Coarse Aggregate - Procedure A (Length to Width Ratio 4:1)	20	N/A
CSA A23.2-14A	Alkali-Reactivity Expansion in Concrete Prisms	0.040 ⁽²⁾	0.040 ⁽²⁾
<u>CSA A23.2-24A</u>	<u>Test Method for the Resistance of Unconfined Coarse Aggregate to Freezing and Thawing</u>	<u>6</u>	<u>N/A</u>

(1) Standard Colour is defined as Organic Plate No. 3

(2) Expansion measured at 1 year

211.05.04 Other Materials – Other materials, such as steel fibres, etc. shall be stored and handled in accordance with the manufacturer's recommendations and instructions.

NOTE: Stockpiled aggregate, which has segregated, contaminated or intermixed with foreign matter of any kind, shall be rejected. Separate batch plant storage bins shall be provided for each size of aggregate to be batched.

Precautions shall be taken when moving, handling and transferring aggregates to prevent contamination, segregation or degradation in accordance with the following recommendations:

- Aggregate blanket 150 mm thick should be left on the ground as stockpiles are depleted.
- Aggregate transfer over stockpiles or storage bins of other sized aggregates should be avoided.

- Storage bins should be filled only to 150 mm from the top unless a suitable extension rim is provided to prevent contamination.
- Front-end loader buckets should be filled by raising them vertically up the face of the stockpile, not by thrusting into the stockpile in one place.
- Depositing aggregates into the batch plant storage bins should be made directly over the bins' outlet.
- Storage bins should be kept as full as possible during batching to minimize segregation as the aggregates are withdrawn from the bins.
- Acceptable and uniform aggregate moisture content shall be obtained and maintained by necessary means to include the following:

SECTION 211

PORTLAND CEMENT CONCRETE

- Washed or wetted aggregates should remain in stockpiles for a minimum of 12 hours to permit a uniform moisture content throughout the stockpile to be reached before aggregate transfer to batch plant storage bins.
- After each day's concrete production during wet weather, fine aggregate bins should be either emptied or covered with a suitable waterproof covering.

211.06 Batching

211.06.01 Batching Equipment

i) **General** – Batching equipment, such as weighing mechanisms, gates, water lines and dispensing systems, shall be maintained in good working order. Batching bins shall be completely emptied of all material before the first and succeeding batches are measured.

Batching equipment shall have the following capabilities and facilities:

- bins or silos for storage of aggregates, silos for storage of cement and pozzolan.
- free movement of each type or size of material to discharge openings without contamination.
- design of storage and hauling facilities to prevent:
 - loss or intermingling of different sizes and types of materials.
 - contamination by deleterious substances.
 - harmful segregation and breakage.
- covers to stockpiles of fine aggregates to ensure constant moisture content.
- all fulcrums, clevises and similar working parts maintained in clean condition.
- provision made, in remote control plants and/or where batch cycles are timed, for the complete filling and discharge of the measuring unit for each batch.

ii) **Batch Charging Mechanism** – Batch Charging Mechanism requirements shall be as follows:

- material flow control within the specified tolerances.
- hopper construction to eliminate material accumulation and to permit the complete discharge of every batch.
- cement weighing hopper:
 - self-cleaning and properly ventilated to allow air to escape.
 - accessible for inspection.
 - dust sealed between the charging mechanism and the hopper to maintain weighing accuracy.

iii) **Scales and Dispensing Mechanism** – Scales and Dispensing Mechanisms shall conform to the following requirements:

- beam type or springless dial type.

- other methods of weighing (electric, hydraulic, load cells, etc.) are acceptable provided the specified weighing tolerances and accuracy requirements are met.
- all accurate to $\pm 0.4\%$ of the total capacity of the scale when static load tested.
- zero balance adjustment capability.
- unaffected by binding or vibration due to vibrators or other appurtenances.
- working range between 10% and 90% of the scale reading.
- equipped with prominent markers with individual batch weight setting capabilities for dial scales.
- calibration facilities including an adequate number of standard test masses.
- beam type scales with provision for indicating to the operator that the required load in the hopper is being approached; the device shall indicate at least the last 100 kg of the load.
- all weighing and indicating devices shall be in full view of the operator while charging the hopper, and the operator shall have convenient access to all controls.

iv) **Volumetric Devices for Water Measurement** – Volumetric devices for water measurement shall be:

- fitted with such valves and connections as are necessary to divert the water measured for a batch to easily verify the accuracy of measurement.
- arranged so that measurements will be unaffected by variable pressures in the water supply line.
- calibrated to an accuracy of 2% of the batch volume.

v) **Dispensing Systems for Liquid Admixtures** - Dispensing systems for liquid admixtures, other than weigh systems, shall have the following capabilities:

- visual, volumetric measuring or readout units located as close as possible to eye level for easy reading by the operator.
- positioned in such a manner that discharge into the batch is observed by the operator from a normal working position.
- volumetric measuring unit for periodic check of dispenser accuracy where a positive displacement system is used.
- visual measuring unit for an accurate visual check of increments of 30 mL of air entraining agent or of chemical required to treat a maximum of 25 kg of cement.

vi) **Certificate or Report of Inspection** – A certificate or report of inspection, from a Weights and Measures approved, independent testing authority, and which is not more than one year old for the plant in its present position, shall be on display in the plant at all times. The certificate or report will be accepted as proof of accuracy of the scales or weighing devices. Where there is reasonable doubt concerning the accuracy of the scales or weighing devices the Ministry Representative may require their recalibration and recertification at the Contractor's expense, during progress of the work. Plant relocation or major alterations shall require such recalibration and recertification.

211.06.02 Batching of Materials – Material may be weigh-batched separately or cumulatively.

Aggregates shall be batched by mass, cement and mineral admixtures in the powder form by mass or bag.

The mass of any ingredient to be batched shall not be less than 10% nor greater than 90% of the scale capacity.

When batched by 40 kg bags, only full and sealed bags of cement shall be used with no fractional bags permitted.

Cement batched by mass shall be to an accuracy of $\pm 1\%$ for batch quantities between 30% and 90% of the scale capacity. When the mass of cement being batched is between 10% and 30% of the scale capacity, the mass of cement batched shall not be less than the required mass nor more than 4% in excess. Intermediate bulk cement shall be weighed to an accuracy of $\pm 1\%$.

When aggregates are measured by mass, batch masses shall be based on the required mass of saturated surface dry aggregate corrected for the moisture conditions of the aggregate at the time of batching. Field determination of free moisture in the aggregates shall be made by any proven method such as CSA A23.2-11A or by the use of a device such as the "Speedy Moisture" gauge. Where doubt exists as to the accuracy of such methods, total moisture in the aggregate shall be determined in accordance with ASTM C566. The minimum test frequency shall be once per each day's production. When individual aggregate weigh batchers are used, the scale reading for each material shall be within 2% of the specified mass. In a cumulative aggregate weigh batcher, the cumulative mass after each measurement shall be within 1% of the required cumulative amount when the scale is used in excess of 30% of its capacity. For cumulative measurement less than 30% of scale capacity, the allowable variation shall be $\pm 0.3\%$ of scale capacity or $\pm 3.0\%$ of the required cumulative mass, whichever is less.

Mixing water shall be measured by mass or volume to an accuracy of $\pm 1\%$. Adjustments for free water contained in batched materials, such as free water in the aggregates, water contained in admixture solutions, shall be made to the quantity of water to be batched. The total amount of mixing water in the batch obtained from all sources shall be within $\pm 3\%$ of the specified quantity and shall not vary the designed water-to-cementitious material ratio of the mix by more than ± 0.02 .

Mixers shall be completely emptied of all water prior to the loading of a concrete batch.

Admixtures shall be batched in liquid form by either mass or volume; in powdered form by mass or bag. Volumetric measurements of admixtures or air entraining agents shall be to an accuracy of $\pm 3\%$ of the required amount or 30 mL, whichever is greater. Measurement by mass shall be to an accuracy of $\pm 3\%$ of the required amount.

The addition of cement to a fully-batched load of aggregates will not be accepted.

211.07 Mixing

211.07.01 General – Sufficient plant capacity and transporting equipment shall be provided by the Contractor to ensure continuous delivery of concrete at the rate required with the necessary intervals between batches, for the proper placing and finishing of the concrete without the formation of cold joints in the finished concrete.

211.07.02 Concrete Mixers

i) **General** – Concrete mixers shall conform to the following requirements:

- manufacturer's rating plate carried in a prominent position, indicating rated mixing capacity, and recommended speed of mixing which must be in the range of not less than 4 nor more than 18 rpm.
- demonstrated capability of operating satisfactorily at the recommended mixing speed.
- number of revolutions of the drum or blades registered with a counter in working condition.
- charge and discharge openings and chute free from appreciable accumulations of cement or concrete, and hopper and chute surfaces clean and smooth.
- batch water measuring equipment in good operating condition.

ii) **Volumetric Mobile Mixers** – Volumetric mobile mixers shall conform to the following requirements:

- Shall be auger type mixers.
- The mobile mixers shall be calibrated with the actual cement and aggregate products used in the concrete mix. Calibration tables and curves shall be submitted to the Ministry Representative. The volume of the concrete produced shall be confirmed and shall be within 2%.
- Mobile mixers shall have separate flow controlled supply hoppers for each individual aggregate gradation and cementitious constituent material to be added volumetrically.

SECTION 211

PORTLAND CEMENT CONCRETE

- May be used provided that the accuracy of batching and uniformity of concrete is as required by CSA A23.1.
- Cement flow rates shall be checked before (during if required) each placing operation.
- The scale being used to calibrate the mobiles shall have a minimum capacity of 50 kg.
- The water tank shall have a stand pipe showing the amount of water in the tank.
- The mobiles shall have individual flow meters and admixture tanks for each admixture to be used as part of an admixture injection system.
- The mobiles shall be able to advance backwards and forwards from controls located at the back of the mobile.
- The mixer auger shall be maintained at minimum of a 25° angle from horizontal when mixing and discharging, unless otherwise indicated by the manufacturer.

211.07.03 Mixing Concrete – Mixing drums shall be clean and empty before being charged. The drum shall be rotated at the manufacturers' recommended mixing speed during charging and mixing. Concrete shall be mixed to the uniformity requirements of CSA A23.1, Section 5.2.3.5. When a satisfactory mixing time is established it shall be maintained for all batches of the same design, mixed with the same equipment.

211.08 Delivery

211.08.01 General – Off-site mixed concrete shall, after being mixed, be transported to the job site in either truck agitators or truck mixers operating at the speed designated by the manufacturer of the equipment as agitating speed.

When concrete is being mixed in mixer trucks while in transit, the speed of the mixing drum shall be reduced to agitating speed once the mixing time has elapsed. Delivery of mixed concrete in non-agitating equipment will not be permitted.

211.08.02 Time of Placement – Time of placement guidelines for bridge decks including diaphragms, bridge parapets, bridge medians, bridge sidewalks and approach slabs are given in SS 413, Bridge Decks and Concrete Overlays.

All other concrete shall be fully discharged and placed within 90 minutes after water and cement have been combined. Under conditions contributing to rapid stiffening of concrete the Ministry Representative may require a time of less than those stated above.

Time of placement extensions will be considered on a case by case basis and may require the use of Hydration Stabilizing Admixtures (HSA's) conforming to the requirements of ASTM C494 Type B, Retarding or Type D, Water-Reducing and Retarding Admixtures. If accepted by the Ministry Representative, guidelines for the use of HSA's shall be as follows:

Concrete shall be fully discharged and placed within 3 hours after water and cement have been combined.

When HSA's are used, these time extensions are subject to preconstruction trials being conducted by the Contractor to establish the appropriate HSA dosage to provide suitable extended slump life of concrete without increasing the water/cementitious ratio of the concrete above that which would be required if HSA's were not used. The use of HSA's shall in no instance modify the maximum concrete temperature required at time of placement. A one time only addition of HSA will be allowed, this will be during initial batching of the concrete or immediately at completion of batching as recommended by the admixture manufacturer. Addition of HSA at any other time will be cause for rejection of the concrete.

211.08.03 Temperature Control – Temperature control guidelines for bridge decks including diaphragms, bridge parapets, bridge medians, bridge sidewalks and approach slabs are given in SS 413, Bridge Decks and Concrete Overlays.

The temperature of all other concrete, from the time of batching to complete discharge shall remain between 10° C and 25° C. Any concrete containing silica fume shall not have a maximum temperature in excess of 17° C at time of placement. Concrete used in elements having a minimum section thickness greater than 1000 mm shall have temperature controls as per CSA A23.1 Clause 5.2.4.4. Methods used for maintaining temperature controls shall not diminish the quality of the concrete, and shall not alter nor exceed the specified maximum W/C_m ratio.

When the atmospheric temperature is 20°C or higher, Clause 211.18 – Hot Weather Concreting shall apply.

211.08.04 Addition of Water – No water shall be added after the initial introduction of the mixing water for the mix, except at the start of discharge within the initial 10% of the total load volume, and when:

- the specified water-to-cementitious materials ratio is not exceeded.
- the measured slump is less than that specified.
- no more than 60 minutes have elapsed after water and cement have been combined.
- the concrete is in a mixer or truck mixer.

An amount not exceeding 16 L of water per cubic metre of concrete or 10% of the mix design water whichever is less may be added. After addition of water, the drum or blades shall be turned an additional 30 revolutions or more if necessary at mixing speed. The amount of water added shall be recorded on the delivery ticket. Water shall not be added to the batch at any later time. The Contractor assumes full responsibility for the on-site addition of water and its subsequent effect on the quality of the concrete.

211.08.05 Addition of Superplasticizer (HRWR) – When superplasticized concrete falls below the designated slump due to delay, it shall be re-tempered with superplasticizing admixtures only, not water, and shall only receive a maximum of one re-tempering. The amount of superplasticizer added shall be recorded on the delivery ticket. The Contractor assumes full responsibility for the on-site addition of superplasticizer and its subsequent effect on the quality of the concrete. The use of superplasticizers shall not be used for extending the time of placement requirements described in SS 211.08.02.

211.08.06 Control of Air Content on the Job Site – The air content of the concrete shall, if necessary, be brought up to the specified range by the addition of an air-entraining agent in the field. Mixing shall follow to ensure proper dispersion and upon completion of mixing, the air content shall be retested. The amount of admixture added shall be recorded on the delivery ticket. The Contractor assumes full responsibility for the on-site addition of the air entraining agent and its subsequent effect on the quality of the concrete.

211.08.07 Delivery Ticket – Concrete delivered to the job site shall be accompanied by a ticket providing the Contractor and Ministry Representative with legible information, as follows:

- serial number of ticket
- date, name and location of concrete supplier.
- name of the Contractor.
- specific job designation (name and location).
- specific designation of concrete mix design.
- truck number and volume of concrete in cubic metres.
- addition of any materials added at the job site, at the request of the Contractor including but not limited to water and all chemical admixtures.
- time concrete was batched, arrived at job site, and completely discharged.
- amount of water added during batching including free moisture in aggregate, the maximum allowable amount of water that can be added at the site to maintain the specified maximum W/C_m ratio.

211.09 Quality Control Inspection, Testing and Acceptance

211.09.01 General – The Contractor shall be fully responsible for hiring, scheduling, overseeing, performing and documenting all quality control testing and inspection in full compliance with the Contract.

The Ministry may perform on-site sampling and testing as a function of the Ministry's quality assurance and/or audit. Ministry quality testing shall not relieve the Contractor of responsibility for providing quality control.

211.09.02 Sampling and Testing – Laboratory testing shall be carried out by a testing laboratory certified in accordance with the requirements of CSA Standard A283. Field test

procedures shall be undertaken by personnel certified under an industry-recognized program. Field inspectors shall have extensive experience in on-site quality control testing of concrete, with the applicable admixtures being used, and with on-site batch adjustments. Testing personnel shall be on-site and available to test concrete for the complete duration of any concrete placement operation. Sampling and testing shall be in accordance with the test methods and minimum frequency levels as listed in Table 211-J and Table 211-K. Any test outside the specified range shall be immediately reported to the Contractor and Ministry Representative. Copies of all test results shall be received by the Ministry Representative within 1 day of the test date.

211.09.03 Sampling – Point of Acceptance – Determination of concrete properties for acceptance will be made based on samples taken at the final discharge end of the placement system. The Ministry Representative may accept sampling at the truck discharge end provided that testing during the test batches confirm that the concrete mix parameters are within the stated specification requirements at the actual placement point. The Ministry Representative may require additional testing to be performed at the point of placement at a predetermined frequency throughout the placement period. Such additional testing, including all costs shall be deemed as part of the Contractor's quality control program.

211.09.04 Strength Tests – Unless otherwise specified, a strength test shall be the average 28-day strength of three standard 100 mm x 200 mm test cylinders, sampled, cast, cured, transported, and tested in accordance with CSA A23.2- 3C and 9C. The cylinder size shall however, meet the aggregate size limitations specified in Clause 6.2 of CSA Test Method A23.2-3C. For each strength test, a fourth cylinder shall be cast for a 7-day strength determination, and if requested by the Ministry Representative, a fifth cylinder shall be cast for a 56-day strength determination. If one specimen in a strength test, in the opinion of the testing agency shows evidence of improper sampling, casting, or testing, including damage from improper handling and transporting (and if agreed to by the Ministry Representative), it shall be discarded and the remaining two specimen strengths averaged. Additional cylinders may be cast, at the discretion of the Ministry Representative or Contractor.

The strength of each classification of concrete shall be considered satisfactory if:

- the averages of all sets of three consecutive strength tests equal or exceed the specified strength.

TABLE 211-J STANDARD TEST METHODS FOR SAMPLING AND TESTING

Test Methodology	Test Description	Minimum Test Frequency
CSA A23.2-1C	Sampling Plastic Concrete	As stated below
CSA A23.2-3C CSA A23.2-9C	Making and Curing Concrete Compression and Flexural Test Specimens Compressive Strength of Cylindrical Concrete Specimens	One set for every 35 m ³ or portion thereafter for each classification of concrete placed within an individual structural element or component, and placed on any one-calendar day from a single supplier. The Ministry Representative may request additional sets.
CSA A23.2-4C CSA A23.2-5C ASTM C1064	Air Content of Plastic Concrete by the Pressure Method Slump and slump flow of Concrete Temperature of Fresh Concrete	Every individual load unless approved otherwise by the Ministry Representative Retests shall be performed following any load adjustments.
CSA A23.2-6C	Density, Yield, and Cementing Materials Factor of Plastic Concrete	Density and Yield tests shall be performed with every air test and strength test.

TABLE 211-K ADDITIONAL TEST METHODS FOR CONCRETE CONTAINING HIGH RANGE WATER REDUCERS (SUPERPLASTICIZERS)

Test Methodology	Test Description / Sample Requirements	Minimum Test Frequency
ASTM C457 ⁽¹⁾⁽²⁾	Microscopic Determination of Parameters of the Air-Void System in Hardened Concrete	One test per individual test batch for each classification of concrete. Acceptance criteria shall be in accordance with CSA_A23.1 Section 4.3.3.2 and 4.3.3.3. Further testing, during scheduled concrete pours may be required, as directed by the Ministry Representative
ASTM C1202 ⁽¹⁾	Electrical Indication of Concrete's Ability to Resist Chloride Ion Penetration (Test age at 56 days)	One test per individual test batch for each classification of concrete Acceptance criteria shall be a coulomb rating not exceeding 1500 coulombs Each test set includes two 100 mm x 200 mm [4" x 8"] cylinders, sampled at the final placement discharge point. Casting, transporting and curing shall be in accordance with SS 211.09.

(1) Testing requirement may be waived at the discretion of the Ministry Representative

(2) For superplasticized concrete only

SECTION 211

- no individual test shows strengths less than 90% of the specified strength.

Each "classification of concrete" will be taken as all of the concrete in one pay item in the Schedule 7. Where fewer than three strength tests are taken, the results of one test or the average of two will be used.

211.09.05 Test Cylinders – Making and curing concrete test cylinders shall be carried out in accordance with CSA A23.2-3C, except that the time for cylinders to reach the testing laboratory shall be between 20 and 48 hours from initial time of casting. The test cylinders shall be cast by the Contractor using standard CSA approved moulds. The Contractor shall provide properly designed temperature-controlled storage boxes for test cylinder storage, as specified in CSA A23.2-3C Clause 7.3.2.1, for a period of at least 20 hours, and further protection from adverse weather and mishandling before and during delivery to the testing laboratory for curing and testing. The Contractor shall provide a maximum-minimum thermometer for each storage box.

The Contractor shall deliver the test cylinders to a CSA certified testing laboratory. Handling and transporting of the cylinders shall be in accordance with CSA A23.2-3C. No extra laboratory curing time will be allowed for cylinders that are delivered late to the laboratory. A copy of the test results shall be forwarded to the Ministry Representative within 2 days of each individual strength test date. Test results shall include all information as described in CSA A23.2, Annex B, Form for Reporting Compressive Strength of Concrete Test Cylinders.

211.09.06 Field Cured Test Cylinders – The Ministry Representative may require field cured test cylinders be cast to check the adequacy of the Contractor's curing or cold weather protection. The Contractor may also cast field cured test cylinders for determining interim strengths that may be required for further work progress approval such as opening to traffic, formwork removal and/or erection, etc.

Casting, handling, transporting and testing shall be in accordance with CSA A23.2-3C and 9C.

Test cylinders shall be stored as near as possible to the point in the structure that the test cylinders represent, and shall be afforded the same temperature protection and moisture environment as the structure.

At the end of the curing period the test cylinders shall be left in place, exposed to the weather in the same manner as the structure.

All test cylinders shall be removed from the field storage and stored in lime water at $23 \pm 2^\circ\text{C}$ for $24 \pm 4\text{h}$ immediately before time of testing to ensure uniform moisture conditions from cylinder to cylinder.

Test results on field cured test cylinders shall not be used as a basis for acceptance or rejection of the concrete.

PORTLAND CEMENT CONCRETE

211.09.07 Failure to Meet Minimum Strength Specifications

i) Low Average – where the average of the strength tests is low, but no test shows less than 90% of the specified strength, the concrete will be accepted at a reduced price (see SS 211.21.02).

ii) Understrength Concrete – where testing shows lower strengths, the Ministry Representative may order replacement or reinforcing, at the Contractor's expense, of portions of the structure. Alternatively, at the Ministry Representative's discretion, the understrength concrete may be accepted at a reduced price (see SS 11.21.02).

iii) Coring – the coring of concrete, to verify its strength, will be allowed only for concrete, which is otherwise to be replaced or reinforced. Coring will not be allowed for concrete for which reduced payment is to be made for understrength. When coring is allowed, cores shall be taken at locations directed by the Ministry Representative, who shall be present during the coring.

Where coring is allowed, it shall be carried out at the Contractor's expense by an independent qualified testing firm. Three cores shall be obtained and tested in accordance with CSA A23.2-14C "Obtaining and Testing Drilled Cores for Compressive Strength Testing" at each test location. Concrete in the area represented by the core tests may be considered structurally adequate if:

- the average strength test result of each set of three cores from the portion of the structure in question is equal to at least 100% of the specified strength
- the strength test result of any single core is not less than 80% of the specified strength

Notwithstanding the final result, the Contractor will be responsible for all costs associated with the coring operation and testing, and shall not be reimbursed for inconvenience and other associated costs.

211.09.08 Failure to Meet Slump or Air Content Specifications – In the event that the slump and/or air content are outside the specified limits, the Ministry Representative may accept adjustments to correct the deficient condition as an alternative to rejection. In such cases, adjustments must be completed within the maximum time allowed as specified in SS 211.08.02 and additional testing shall be required to verify specification compliance. If compliance is not achieved, the concrete shall be rejected.

211.10 Placing of Concrete

211.10.01 General – Equipment for conveying concrete at the job site, such as buggies, buckets, hoppers, chutes, belts and pumps, shall be of such

design, size and condition to deposit a continuous and adequate supply of concrete of the specified mix and consistency without segregation at the required locations.

211.10.02 Buggies – Buggies shall have inflatable rubber tires. Inner surfaces of the bucket shall be smooth with filleted corners, mortar-tight and free of any excessive accumulation of hardened concrete, obstructions or deterioration interfering with the proper discharge of concrete. Grade and ramp-way surfaces shall be sufficiently smooth to prevent segregation of concrete being carried in buggies.

211.10.03 Bottom-dump Buckets and Hoppers – Bottom-dump buckets and hoppers shall have side slopes not less than 60° from the horizontal and shall be equipped with wide free-working and tight-closing discharge gates. The discharge gates shall be constructed to regulate the concrete flow, spring loaded to ensure complete closure and be capable of immediate closure at any time during discharge. Buckets and hoppers shall be cleaned of any accumulation of partially hardened or hardened concrete before and during concrete placement. Gate control mechanisms shall be cleaned and lubricated before being used.

In the use of crane and bucket, segregation of concrete from jarring or shaking shall be prevented. Side-dump buckets shall be used whenever necessary to avoid conflict with extended reinforcing steel or formwork.

211.10.04 Chutes – Chutes shall be of rounded cross section to avoid the accumulation of concrete in corners; be capable of slope adjustment sufficiently steep to permit flow without requiring a slump greater than that specified or required for placement (slope normally required is 1 vertical to 2 or 2½ horizontal).

Baffles and changes in direction may be used to control flow, but not vibration, paddling or water spray.

Chutes or belts shall be rigidly supported but sufficiently mobile to permit discharge as close as possible to the placement location as it progresses. Any long line of chutes or belts shall be covered during hot, dry or windy weather to prevent drying of concrete and excessive slump loss.

211.10.05 Conveyor Operation Rate – Conveyor operation rate shall be dependent on the proper placement and consolidation of the concrete with the belt inclination such that no segregation occurs from any sliding or roll-back of the concrete.

211.10.06 Hoppers – Hoppers, set approximately level, shall be supported on specially framed bearers transmitting only vertical loads to the top of the formwork.

211.10.07 Pumps – Pumps shall be of sufficient capacity to supply un-segregated concrete, using the design mix proportions at the design slump, to meet the required placement volume at the forms. Satisfactory operation and performance of the proposed pumping equipment with the concrete materials and mixes otherwise suitable and appropriate for the job, along with the line layout and grate size opening, shall be

demonstrated to the Ministry Representative's satisfaction and acceptance.

Any necessary priming of the concrete pump shall be done with a water/cement or water/cement/sand slurry. The prime slurry followed by approximately 0.25 cubic meters of concrete shall not be included in the concrete placement. No other pump aid type admixtures will be permitted.

211.11 Falsework and Formwork

211.11.01 General – Formwork and falsework shall be designed, supplied, installed and removed in accordance with CAN/CSA-S269.3-M92, CAN/CSA-S269.1-1975 and the requirements for concrete formwork and falsework given in the British Columbia Workers Compensation Act, Occupational Health and Safety Regulations unless otherwise noted.

Formwork and falsework support accessories shall not be welded to the permanent structural steelwork.

Where required, formwork and associated temporary falsework design and drawings shall be prepared and sealed by a professional engineer registered with the Association of Professional Engineers and Geoscientists of British Columbia and experienced in the design and construction of falsework and formwork structures similar to those required to construct this project. No load shall be placed on the formwork or falsework until the professional engineer responsible for the design has inspected and certified, in writing, that the work has been carried out in accordance with the formwork drawings and specifications and a copy of the formwork design engineers' certification has been received by the Ministry Representative.

Bridge deck formwork design shall include a check for the lateral stability of the girders during the placement of deck concrete. Stringers shall be temporarily braced, if necessary, to facilitate deck concreting operations.

Detailed falsework and formwork drawings shall be submitted to the Ministry Representative for review. The drawings shall be submitted a minimum of two weeks before the start of installation.

211.11.02 Design – All forms shall be designed and built mortar-tight and of sufficient rigidity to prevent distortion due to the pressure of vibrated concrete and other loads incidental to the construction operation. The forms shall be substantial and unyielding, and shall be designed so that finished concrete will conform to the design dimensions and contours. The shape, strength, rigidity, water tightness and surface smoothness of re-used forms shall be maintained at all times. Forms which are unsatisfactory in any respect shall not be used.

SECTION 211

All formwork and falsework shall be designed to be completely removable, no stay in place formwork will be permitted.

No dry ties shall be permitted; form tie rods shall remain embedded and terminate not less than 50 mm from the formed face of the concrete. Removable embedded fasteners on the ends of the rods shall be such as to leave holes of a regular shape for reaming and filling.

For narrow walls and columns, where the bottom of the form is inaccessible, removable panels shall be provided in the bottom form panel to enable cleaning out of extraneous material immediately before placing the concrete.

211.11.03 Forms for Exposed Surfaces – All forms for exposed surfaces shall be mortar-tight. All exposed edges shall be chamfered by use of a chamfer strip and return corners filleted. Metal bolts or anchorages within the forms shall be so constructed as to permit their removal to a depth of at least 50mm from the concrete surface. Break-back type form ties shall have all spacing washers removed and the tie shall be broken back a distance of at least 50 mm from the concrete surface. All fittings for metal ties shall be of such design that, upon their removal, the cavities which are left will be of the smallest possible size. Torch cutting of steel hangers and ties will not be permitted. Formwork hangers for exterior surfaces of decks and curbs shall be an acceptable break-back type with surface cone, or removable threaded type. Cavities shall be filled with cement mortar and the surface left sound, smooth, even and uniform in color. See SS 211.17 for details on finishes, mortar mixes and other relevant information.

211.11.04 Deck Formwork – Formwork for decks, curbs, sidewalks and parapets shall be fabricated so that the lines and grades shown on the drawings are achieved. For suspended slab bridge decks the formwork shall be designed to allow for an adjustable haunch to facilitate the casting of a constant depth deck slab as shown on the Drawings. Girders will be erected to normally accepted standards of tolerance; it shall be necessary to adjust the formwork to compensate for camber, variances in girder dimensions, positioning, and sweep.

Prior to commencing deck formwork and subsequent to the completion of the erection of girders, with the girders in a thermally neutral condition and with no dead load other than the dead load of the girders and necessary fall protection, the Contractor shall profile all the girders. Camber elevations are to be taken at 2000 mm centres maximum (or as indicated on the Drawings or Special Provisions), centrelines of all bearings and ends of girders. The camber elevation locations are to be laid out to an accuracy of 25 mm horizontally and camber elevations taken to the nearest 1mm vertically. Within 14 days of the Contractor supplying the camber elevation to the Ministry Representative, the Contractor will receive haunch heights for setting the deck slab soffit, and the design finished grade elevations for the deck, complete with anticipated dead load deflections at 1000 mm stations along the centreline of roadway.

PORTLAND CEMENT CONCRETE

In the event that actual girder camber values vary significantly from the design values, the Contractor will be required to modify the original design finished grade as directed by the Ministry Representative.

211.11.05 Removal of Falsework and Formwork – Where formwork and associated falsework have been engineered by a professional engineer, forms and their supports shall not be removed without the approval of the professional engineer responsible for the formwork and falsework design and without the acceptance of the Ministry Representative. In determining the time for the removal of falsework and formwork, consideration shall be given to the location and character of the structure, the weather and other conditions influencing the curing of the concrete, and the materials used in the mix.

Supports shall be removed in such a manner as to permit the concrete to uniformly and gradually take the stresses due to its own weight together with any construction loads likely to be imposed. All formwork must be removed from the completed structure.

211.12 Construction Joints

211.12.01 General - Definition – Joints between adjacent or successive lifts of concrete where the previously cast concrete cannot be plasticized with a vibrator, or any joint required by the Contractor's method of construction. Construction joints generally shall be in accordance with the following requirements:

- kept to a minimum.
- concealed by a natural break or line in the structure.
- provided for by the formwork design and placing techniques.

Emergency construction joints shall conform as nearly as possible to planned joints. In any case, concrete must be levelled as well as possible and, if lifts are partial, a vertical bulkhead shall be installed. Permission from the Ministry Representative shall be required to complete the cast following any emergency joint installation.

211.12.02 Joint Edges – Joint edges shall be preformed whenever possible for a true line upon form removal. Pour-strip shall be positioned relative to form ties so as to minimize form bulge at the bottom of the subsequent cast, but concrete may be cast to the top of a form instead of the pour-strip. Concrete surfaces outside of the reinforcing steel shall be steel trowelled to a true line.

211.12.03 Surfaces Preparation – Joint surfaces of the hardened concrete shall be thoroughly cleaned of foreign matter and laitance to present clean, sound

SECTION 211

PORTLAND CEMENT CONCRETE

surfaces with the coarse aggregate partially exposed and achieved by:

- brushing immediately following initial set.
- treatment with a surface set retardant, followed by green cutting.
- sand blasting.
- water blasting.

Where roughening of the hardened concrete is specified, the surface shall be roughened to a full amplitude of at least 5mm.

211.12.04 Bonding of Joints – Bonding of joints shall be achieved through the use of a water-cement slurry or, if specified, an epoxy-type bonding agent conforming with ASTM C 881M applied in strict accordance with the manufacturer's specifications. Slurry, when used, shall have a water-cement ratio equal to that of the concrete being placed and be brush applied to a 3 to 5 mm thickness for 100% coverage on to the cleaned existing concrete surface within five minutes of placing concrete.

211.13 Consolidation

211.13.01 Vibrators – General – The number, type, design and operation of vibrators will be subject to the acceptance of the Ministry Representative.

Vibrators shall have the following capabilities and requirements:

- diameter and frequency of vibrators shall conform to Table 211-L.
- vibration transmission to the concrete at frequencies not less than 130 Hz.
- vibration intensity sufficient to be visually observed on concrete with not more than 25 mm slump over a radius of at least 450 mm.
- sufficient number of vibrators available to properly compact each 8 m³ batch within 15 minutes after it is placed in forms, with at least two vibrators provided for each concrete placing unit.
- stand-by vibrator and generator available on the job at all times in case of breakdown.

211.13.02 Mechanical Vibrators – Mechanical vibrators

shall thoroughly consolidate concrete immediately after placing.

Vibrator usage shall be as follows:

- not inserted between reinforcing steel and formwork nor directly on to the reinforcing steel.
- inserted vertically at a rate of 75 mm per second and penetrating into the preceding layer at least 50 mm.
- withdrawn at a rate of 150 mm per second.
- grid pattern movement starting 100 mm from a formed surface and at a maximum spacing of 300 mm thereafter.

211.13.03 Form Vibrators – Form vibrators may be permitted at the discretion of the Ministry Representative where rebar configuration would prohibit the use of internal vibrators.

211.14 Finishing

211.14.01 Finishing Top Surfaces – Plastic concrete, struck off immediately following casting and before the accumulation of bleed water, shall be finished by hand or mechanical floating with the least possible disturbance. Water, cement or proprietary topping material shall not be added to the surface during finishing.

No steel floats or trowels shall be used on exposed surfaces.

211.14.02 Strike-off and Finishing Machines – Strike-off and finishing machines for surfacing concrete such as slabs on grade, pavements, etc. shall conform to the following:

- capable of accurately finishing concrete surfaces to the grade and elevation shown on drawings or as directed by the Ministry Representative.

TABLE 211-L REQUIREMENTS FOR DIAMETER AND FREQUENCY OF VIBRATORS

DIAMETER (mm)	FREQUENCY (Hz)	RATE OF PLACEMENT OF CONCRETE PER VIBRATOR (m ³ /h)	APPLICATION
20-40	170-250	1-4	very thin members
30-60	150-225	2-8	walls and slabs 200 mm - 300 mm
50-90	130-200	5-15	larger members

- capable of accurately finishing concrete surfaces to the grade and elevation shown on drawings or as directed by the Ministry Representative.
- surface finish production free of open texturing, plucked aggregates or projections.
- maintained in good mechanical repair and free of hydraulic fluid leaks, oil leaks, excessive grease and other contaminants.

211.14.03 Trowel Finishing – Trowel finishing where required:

- by the drawings or specifications,
- for unformed surfaces exposed to view from a close distance,
- by close tolerance requirements (such as bearing surfaces),

shall be commenced after bleed waters have disappeared to reduce the texture of the concrete surface and produce a smooth blemish-free surface.

211.14.04 Other Textured Finishes – Other textured finishes shall be applied as and where specified.

211.14.05 Damage or Scaling – Any damage to or scaling of surfaces shall be repaired to the satisfaction of the Ministry Representative.

211.15 Curing

211.15.01 General – Freshly deposited concrete shall be protected from freezing, abnormally high temperatures or temperature differentials, premature drying, excessive moisture, moisture loss, heavy shocks, excessive vibrations and high stresses, for the period of time necessary to develop the desired properties of the concrete.

The curing period will begin following the placement of the concrete in the section cast. It shall be the responsibility of the Contractor to ensure that the system of curing and protection is properly planned, constructed and maintained throughout the entire curing period.

211.15.02 Acceptable Methods and Procedures – Acceptable curing methods and procedures shall include the following:

- concrete surfaces shall be cured for a period of seven consecutive uninterrupted twenty-four hour periods, however, if the Ministry Representative has accepted the use of high-early strength cement(HE), this period may be reduced as permitted by the Ministry Representative.
- surface temperature maintained between 10°C and 35°C, unless high-temperature curing (i.e., by hot blankets or steam) is acceptable to the Ministry Representative.
- hot weather and cold weather special requirements are

covered by SS 211.18 and SS 211.19. The determination and recording of air and concrete temperatures to verify compliance with the requirements for hot and cold weather concreting shall be the responsibility of the Contractor. The location and methodology for the determination and recording of temperatures shall be acceptable to the Ministry Representative.

- formed concrete protection, with form-work left in place during the curing period (usually seven days), is generally not necessary except during extremes of hot or cold weather temperatures. Where formwork is removed before the end of the curing period, the concrete shall be protected in the manner specified below for unformed surfaces during the remainder of the curing period.
- unformed surface protection using burlap and water or where permitted, other moisture-retaining methods considered adequate to promote curing, shall include the following common methods and requirements:

i) Burlap – Soaking wet burlap of acceptable quality shall be carefully laid on the surface of the concrete as soon as the concrete has set sufficiently to support the burlap without marring the surface. Strips shall be overlapped 150 mm, adequately held down and maintained in place in a thoroughly wet condition throughout the curing period (usually seven days). Wetness of burlap shall be maintained at all times.

ii) Vapour Barrier – Vapour barrier of acceptable quality of opaque white-pigmental 0.10 mm thick ("4 mil") polyethylene sheet, white upper surfaced paper or other permitted material shall be of such size and placement to minimize the number of laps. The material shall be laid, lapped and held down around the edges and at the laps:

- to prevent displacement.
- to provide and maintain an effective vapour barrier.
- prevent any flow of air between the vapour barrier material and the concrete.
- kept in place throughout the curing period (usually seven days).

However, the barrier material shall not be pulled tight against the fresh concrete surface so as to smooth the required surface texture.

211.15.03 Removal of Protective Materials – Protective materials shall be removed entirely from all concrete surfaces at the end of the curing period and the surfaces left clean.

SECTION 211

PORTLAND CEMENT CONCRETE

211.16 Dimensional Tolerances – Dimensional tolerances shall be as shown in Table 211-M.

211.17 Finishing Formed Surfaces

211.17.01 Class 1 Finish – Class 1 Finish is the basic finish to be produced on all formed surfaces not exposed to view unless a better finish is specified or required by the Drawings or Special Provisions.

In order to produce a Class 1 finish, the formwork shall be mortar tight. Panel marks and texture are of no importance.

All ties, bolts, nails and other metal specifically required for construction purposes shall be removed or cut back to a depth of 50 mm from the surfaces of the concrete and the resulting holes filled.

No dry ties shall be permitted; form tie rods shall remain embedded and terminate not less than 50 mm from the formed face of the concrete. Removable embedded fasteners on the ends of the rods shall be such as to leave holes of a regular shape for reaming and filling.

Honeycombs and voids over 500 mm² in area shall be filled. Honeycombs and voids shall not be repaired until inspected by the Ministry Representative as special methods of repair may be required where occurring in structural elements. Otherwise, concrete surfaces shall be repaired as follows:

- remove all porous concrete by cutting 20 mm into sound concrete.
- thoroughly clean reinforcing steel without damaging same.
- cut edges of cavities as nearly perpendicular to the concrete surface as possible and deep enough to hold the patching mortar.
- keep surrounding concrete saturated for 30 minutes before patching.
- after the sheet of free water has disappeared from the concrete surfaces, apply a latex bonding agent, in strict accordance with the manufacturer's instructions.
- patch with mortar, proportioned as specified in SS 211.17.05 and mixed with the minimum amount of water necessary to make a workable paste: for voids deeper than 10 mm, multiple layers of mortar each with a maximum thickness of 10 mm shall be used with 30 minute intervals allowed between layers.
- trowel the surface of the patch flush with the surface of the surrounding concrete.

211.17.02 Class 2 Finish – Class 2 Finish is to be produced on all formed surfaces exposed to view from a moderate distance, such as surfaces of abutments and piers, and to any surfaces for which a Class 2 finish is specified or required by the Drawings or the Special Provisions. A Class 2 finish shall provide surfaces of uniform colour and texture as viewed from 25 m.

In order to produce a Class 2 finish, formwork shall be mortar

tight and shall render a true surface. Fins 3 mm wide (maximum) shall be allowed at the panel joints; however, sheathing joints must be mortar tight. Irregularities of 3 mm in height with areas of 50 mm x 75 mm shall be allowed to a maximum of four such areas per 3 m² of formwork. Patches of dissimilar material will not be permitted. Horizontal and vertical joints shall be aligned.

All ties, bolts, nails and other metal specifically required for construction purposes shall be removed or cut back to a depth of 50 mm from the surfaces of the concrete and the resulting holes filled.

No dry ties shall be permitted; form tie rods shall remain embedded and terminate not less than 50 mm from the formed face of the concrete. Removable embedded fasteners on the ends of the rods shall be such as to leave holes of a regular shape for reaming and filling.

Honeycombs and voids over 25 mm diameter shall be filled, and all bugholes over 5 mm diameter shall be pointed. All fins and projections shall be removed with a hand stone or power grinder. The use of a power grinder shall be kept to a minimum and confined to the areas required.

When a rubbed finish is not called for, patches shall be textured with a mortar float or lightly brushed after trowelling smooth.

Where more than 50 voids or bugholes over 5 mm diameter occur per square metre, or if the surfaces are not acceptably uniform in colour or texture, the entire area affected shall be given a rubbed finish, as follows:

- allow patches to attain an initial set.
- keep surfaces saturated with water for 60 minutes before applying mortar.
- remove free water from surfaces.
- apply mortar, proportioned as specified in SS 211.17.05 and mixed at least 60 minutes before application, to the concrete surfaces with a sponge, float or a hand carborundum stone, and work mortar well into the surfaces.
- allow mortar to dry 30 - 60 minutes.
- remove residues from the surfaces by rubbing with clean dry burlap but with no addition of neat cement to the surface during the "sacking" operation and finally cure the surfaces as specified in SS 211.15.

Table 211-M DIMENSIONAL TOLERANCES

Trueness of bearing surfaces	such that there is no gap over 1 mm under a 1 m straight edge
Trueness of bridge deck surfaces	such that there is no gap over 3 mm under a 3 m straight edge
Trueness of slope pavement surfaces	such that there is no gap over 12 mm under a 3 m straight edge
Trueness of other surfaces exposed to view	such that there is no gap over 12 mm under a 3 m straight edge
Curbs and parapets	such that there is no gap over 3 mm under a 3 m straight edge
Horizontal distance to concrete surfaces	±50 mm
Elevations of concrete surfaces except bearings and decks	±25 mm
Elevations of bridge deck surfaces	±15 mm
Elevations of bearing surfaces	±5 mm
Variation from plumb	1:400, but not more than 30 mm
Dimensions of members over 10 m	±25 mm
Dimensions of members under 10 m	-6 mm, +15 mm
Location of anchor bolts	± 6 mm
Projections of anchor bolts, other embedments	±13 mm

NOTE: The tolerances listed in Table 211-M are acceptable only in so far as they do not prevent the proper fit of structural members.

In order to produce a Class 3 finish, the formwork shall render a true smooth surface, free from fins and projections. New plywood or steel is necessary to produce the required finish. Re-use of plywood forms will be permitted only if in an "as new" condition. Repairs to the forms shall be with full panels of sheathing only.

All ties, bolts, nails and other metal specifically required for construction purposes shall be removed or cut back to a depth of 50 mm from the surfaces of the concrete and the resulting holes filled.

No dry ties shall be permitted; form tie rods shall remain embedded and terminate not less than 50 mm from the formed face of the concrete. Removable embedded fasteners on the ends of the rods shall be such as to leave holes of a regular shape for reaming and filling.

Patching shall be:

- patch installation projecting slightly from the surrounding concrete surface.
- after 24 hours, saturated and carefully finished to render the surfaces of the patch true to the surrounding concrete, but any grinding using a hand carborundum stone kept to a minimum.

When a rubbed finish is required, the applied mortar shall be carefully worked into the surface area being finished and, using a hand carborundum stone manipulated in a circular motion, the entire surface rendered true and smooth with all excess mortar removed.

211.17.04 Class 3 Finish Alternative Procedures – Class 3 Finish alternative procedures when, in the

SECTION 211

opinion of the Ministry Representative, the formwork may safely be removed at an early age and the concrete finished while still partly plastic, shall include the following:

- careful removal of the formwork when the concrete has sufficiently hardened so as to hold its shape.
- finishing the surfaces immediately (within 4 to 8 hours of casting, depending upon weather).
- careful rubbing of the concrete surfaces with a carborundum stone, occasionally wetting same to produce a paste from the surface of the concrete.
- rubbing continued, adding necessary sand-cement mortar in small quantities to fill voids, until all voids and form marks are removed.
- surface curing as specified.

Modifications to the surface texture shall be achieved by grinding or other means.

211.17.05 Patching Mortar – Patching mortar where specified above shall be constituted as follows:

Cement:	60% Normal Portland 40% White Normal Portland
Liquid:	70% Water 30% Latex Bonding Agent
Sand:	Passing a 1.25 mm sieve

NOTE: Cement blend above may be adjusted to provide close match to the concrete colour.

211.18 Hot Weather Concreting

When ambient air temperature is 25°C or higher or there is a probability of it rising to 25°C during the placing period (as forecast by the nearest official meteorological office), hot weather concreting procedures as outlined below, shall be used, for all concrete other than deck concrete. Additional requirements for hot weather concreting for bridge decks including diaphragms, bridge parapets, bridge medians, bridge sidewalks and approach slabs are given in SS 413, Bridge Decks and Concrete Overlays.

Prior to the placement of concrete, the Contractor shall submit to the Ministry Representative for acceptance, the proposed placing operations complying with the requirements for hot weather concreting.

Curing shall be accomplished by water spray or by using saturated absorptive material, such as burlap.

Formwork, reinforcement and concreting equipment shall be protected from the direct rays of the sun or cooled by fogging and evaporation.

Concrete for piers, abutments and footings of bridges shall not have a temperature greater than 25°C at any time prior to placement and curing.

The initial temperature of concrete prior to placement may be

PORTLAND CEMENT CONCRETE

estimated from the temperatures of its ingredients by using the following equation:

$$T = \frac{22(T_a M_a + T_c M_c) + T_w M_w + T_{wa} M_{wa}}{0.22(M_a + M_c) + M_w + M_{wa}}$$

where T_a , T_c , T_w and T_{wa}

= temperature in °C of aggregates, cementing materials, added mixing water, and free water on aggregates, respectively

where M_a , M_c , M_w and M_{wa}

= mass in kilograms of aggregates, cementing materials, added mixing water, and free water on aggregates, respectively

If deemed necessary, the Contractor shall employ the following hot weather concreting procedures to reduce the concrete temperature:

a) Mixing Water

- Shading of storage tanks and water supply lines;
- Refrigeration of mixing water; and/or
- Adding cubed, shaved or chipped ice directly to the concrete mixer drum, and ensuring ice is of a particle size to be completely melted before the concrete is discharged from the mixer drum for placement.

b) Aggregate

- Shading of coarse and fine aggregate stockpiles; and/or
- Wetting of coarse aggregate and allowing time for drainage of free water.
- Note that wetting down of stockpiles of fine aggregate is not permitted.

c) Mixing – Mixing time should be kept to a minimum, allowing adequate time for complete mixing of the concrete. The external surface of the mixing drum should be frequently wetted down.

d) Placing – Production of concrete during hot weather shall be scheduled for a continuous supply of concrete at the job site.

Adequate manpower, equipment and standby provisions shall be provided in order to place and consolidate the delivered concrete within 45 minutes after initial mixing. Further, the time interval between placing batches shall not exceed 30 minutes.

Time of placement extensions during hot weather concreting may be considered by the Ministry Representative and may require the use of Hydration Stabilizing Admixtures (HSA's) conforming to the requirements of ASTM C494 Type B, Retarding or

SECTION 211

Type D, Water-Reducing and Retarding Admixtures. Use of HSA's shall be in accordance with SS 211.08.02.

For large unformed surfaces, the quantity and rate of placing of concrete shall be dependent upon the rate of finishing and climatic condition.

When the rate of evaporation from unformed surfaces as estimated from Drawing SP211-01 "Surface Evaporation Rate" exceeds 1.0 kg/m²/hr, either concrete operations shall cease or, upon acceptance of the Ministry Representative, necessary precautions taken to prevent plastic shrinkage as detailed in CSA A23.1 Section 7.4.2.2.

e) Curing during hot weather shall be commenced as soon as possible.

Forms shall be kept moist and loosened as soon as this can be done without structural damage, with a flow of water introduced and allowed to run down inside.

Newly exposed concrete surfaces shall be protected from premature drying by the application of pre-wetted curing materials or a continuous water spray as the forms are removed.

Large exposures of concrete require special precautions as follows:

- burlap application commenced as soon as the surface will support the mass without excessive deformation, with this surface kept continuously wet by fog spraying until a waterproof barrier is securely in place.
- concrete under the curing blanket is not allowed to dry out for a minimum of seven days from the time of initial covering, necessitating frequent checking and soaking by the addition of water under the top evaporation barrier.
- wet curing followed by the removal of the evaporation barrier only under such conditions that the wetted burlap is permitted to dry slowly before removal and the surface is exposed to prevent excessive thermal shock.

211.19 Cold Weather Concreting – Cold weather concreting procedures shall be used when the ambient temperature is, or is forecast to be, below 4°C during placement, and/or is forecast to fall below 4°C during the first seven days after placing. The Contractor shall be fully responsible for the protection of concrete during cold and adverse weather conditions and shall maintain a minimum concrete temperature of 10°C for a minimum of seven continuous days. Prior to the placement of concrete, the Contractor shall submit to the Ministry Representative for acceptance, the proposed placing operations complying with the requirements for cold weather concreting. The following provisions for cold weather concreting shall apply:

a) All aggregate and mixing water shall be heated to a temperature of at least 20°C but not more 65°C. However, the temperature of the combined water and aggregates shall not exceed 40°C when combined with the cement. The temperature of the concrete shall be between 10°C and 25°C at the time of

PORTLAND CEMENT CONCRETE

placement.

b) Aggregates shall be heated to eliminate frozen lumps, ice and snow without overheating or excessive drying. Aggregates shall not be heated above 65°C, and all lumps of frozen aggregate shall be excluded from the mix.

c) Formwork, Reinforcing Steel: Before any concrete is placed, all ice, snow or frost shall be completely removed from the forms and the temperature of contact surfaces raised to a minimum of 5°C, with such minimum established and maintained for at least one hour prior to placement.

Heat shall be applied uniformly and at a rate which will not induce excessive thermal stresses in the section being heated. Ambient air temperatures shall not exceed concrete temperatures by more than 13°C and shall be raised at a maximum rate of 2°C/hr.

Projecting reinforcing steel shall be insulated when temperatures are between 0°C and -10°C for a minimum of 300 mm away from the fresh concrete and for a minimum of 600 mm when temperatures are below -10°C.

d) Other Contact Surfaces: Concrete shall not be placed on frozen surfaces except in pile founded footings where a minimum layer of 25 mm rigid insulation shall be installed. Rock surfaces shall be heated by forced air. Heating shall continue until all standing frost crystals are dissolved. Frozen embankment shall be thawed and recompact prior to placing concrete thereon. The temperature of existing concrete work shall be raised to a minimum of 5°C and maintained at this temperature for a time sufficient to raise the entire mass of concrete to this temperature.

e) Curing and Protection necessary to maintain a minimum concrete temperature (10°C) shall be provided throughout the curing period.

Heated enclosures shall be kept at 95% minimum relative humidity. Concrete surfaces shall be protected by formwork or impermeable membranes from direct exposure to the combustion gases of heating. The use of salamanders, coke stoves, oil or gas burners and similar spot heaters which have an open flame and intense local heat is prohibited without the Ministry Representative's acceptance. The enclosed air temperature shall not be less than 10°C nor more than 26°C.

Where practical, insulated forms, capable of maintaining the surface of the concrete at not less than 10°C for a period of seven days, may be used instead of enclosures and heating. If forms are insulated, exposed horizontal surfaces shall be protected with a similar layer of the insulating material securely

SECTION 211

PORTLAND CEMENT CONCRETE

fastened in place. If the insulated forms do not maintain the proper temperature at the concrete surface, auxiliary protection shall be used to provide additional heat as described above.

The determination and recording of air and concrete temperatures to verify compliance with the requirements for cold weather concreting shall be the responsibility of the Contractor.

The Contractor is responsible for furnishing and using a 24-hour minimum/maximum or continuous temperature recording thermometer to record the air temperature within the enclosure and/or insulated forms. Daily records shall be submitted to the Ministry Representative upon request.

At the end of the curing period, heating and protection shall be withdrawn in such a manner so as not to induce thermal shock stresses in the concrete. The temperature of the concrete shall be gradually reduced at a rate not exceeding 10°C per day to that of the surrounding air. To achieve this, in a heated housing, the heat shall be slowly reduced and then shut off, and the whole housing allowed to cool to air temperature before the housing itself is removed. However, the protection shall not be removed until the temperature of the concrete has fallen to within 10°C of the temperature of the outside air.

211.20 Underwater Concreting – Underwater concreting procedures shall be used when structures, or parts of structures, are to be constructed under water. The concrete, methods of placement either by pumping or tremie pipes, and equipment shall be in accordance with the following, or as otherwise directed by the Ministry Representative:

a) Proposals outlining procedures shall be submitted for review to the Ministry Representative 3 weeks prior to placement of concrete. Placement shall comply with the provisions of the proposal.

b) Materials shall conform to the requirements of SS 211.04, except that coarse aggregates shall contain not more than 25% angular particles by mass.

c) Mix proportions shall be as specified in SS 211.03, except:

- cement content not less than 400 kg/m³.
- water-cement ratio no greater than 0.40.
- plasticized slump of 150 mm ±20 mm.
- admixtures used to achieve plastic, cohesive and flowable concrete if acceptable to the Ministry Representative.
- retarding type admixture if accepted by the Ministry Representative shall be used to prevent the formation of cold joints with the lift method of placement or where the concrete surface area is large.

d) Heating of water or aggregates or both, to obtain a suitable placing temperature, shall be done in accordance with SS 211.19. Concrete, when mixed, shall have a temperature of between 15°C and 25°C and shall not be placed in water having a temperature less than 2°C.

e) Cofferdams or forms into which concrete is to be placed

shall be sufficiently tight to prevent the loss of mortar and, if in running water, reduce the velocity of flow within the cofferdam or forms to not more than 3 m per minute. Dewatering will not be permitted until at least 24 hours after concreting has been completed.

f) Pumping and tremie pipe requirements shall be as follows:

- length sufficient to reach the lowest point of deposit but held 150 mm to 250 mm above the bottom of the placement.
- submerged into the placed concrete and held in a near vertical position at all times.
- supported in such a manner to allow vertical movement.
- discharge at locations not farther apart than 7 m.
- discharge end fitted with a 3 m section of steel pipe.
- fed by either chutes or pumps with a continuous flow of concrete.

g) Priming of tremie pipes shall be by inserting a plug of burlap, 25 mm less in diameter than the tremie pipe, in the top of the pipe and carefully controlling concrete flow as the plug passes through the pipe. Where priming is lost, the priming procedure shall be repeated.

h) Concrete flow, once begun, shall be continuous through the pipe, at a minimum of 15 m³ of concrete supplied to each tremie or pump per hour, but controlled so as not to overflow the feed hopper. The flow of concrete shall be continuous to the end of the batch and the pipe lowered in the placed concrete to maintain its prime.

i) Placement of concrete underwater shall be either to the full depth of placement or in lifts and shall conform to the following requirements:

- seals shall be placed by beginning at one end and continuing until final grade is achieved.
- point of placement shall be relocated by approximately 3 m, either laterally or longitudinally and placement continued to grade.
- above procedures repeated to the completion of the seal or when the lift method of placement is used.
- flow of concrete shall be regulated to produce approximately horizontal surfaces.
- each lift placed before the preceding lift has taken initial set.
- depth and area of each lift dependent upon the rate of placement.

SECTION 211

PORTLAND CEMENT CONCRETE

Concrete in its plastic state shall not be disturbed either directly or indirectly by puddling or vibration.

Should interrupted placement be sufficient for the concrete to take initial set, the laitance shall be removed from the concrete surface before concreting is resumed, but with the resumption of concreting delayed indefinitely, laitance shall be removed not later than 36 hours after the interruption.

211.21 Measurement and Payment

211.21.01 Formwork – Payment for formwork will be made at the Unit Prices bid per square metre. Payment shall be for the supply, construction and removal (if required) of formwork, and for the finishing, as required, of formed surfaces. Areas shall be measured of the faces of forms in contact with the concrete.

Payment will be made for forming one face of vertical construction joints which are shown on the Drawings or ordered by the Ministry Representative. No payment will be made for forming construction joints not so required. Payment will be made for forming both faces of joints formed by casting in sheets of styrofoam or other material, where such joints are required by the Contract Documents.

Payment will not be made for forming surfaces which are cast against permanent embedded items which are paid for separately.

Upper surfaces which form an angle of 45° or less with the horizontal, will not usually be considered to be formed surfaces.

The undersides of members which are shown on the Drawings to rest on ground or fill will not be considered formed surfaces. The undersides of members which are not shown on the Drawings to rest on ground or fill will be considered formed surfaces.

Where sides of footings or faces of walls are cast against ground or fill (if permitted by the Ministry Representative) the surfaces so formed will be considered formed surfaces. Only the areas of the surfaces shown on the Drawings will be paid for.

Progress payments will be made according to Table 211-N.

TABLE 211-N PROGRESS PAYMENTS

Progress Payments	Application
60%	for formwork in place
20%	For Formwork removed
20%	For surface finishing completed

211.21.02 Concrete – Payment for concrete will be made at

the Unit Prices bid per cubic metre (or at a reduced price for understrength concrete-see third paragraph of this subsection) prorated at 90% for the supply, transportation, placing, and finishing (except the finishing of formed surfaces) of concrete, and for everything supplied and done in connection therewith, except formwork and reinforcing steel. Payment for curing, prorated at 10% will be made pending satisfactory completion of the specified curing process. No payment will be made for partial curing. Failure to comply strictly with the specified curing process will result in forfeiture of payment for curing. The Ministry Representative shall take measures as required to provide the specified curing. Should the cost of these measures exceed the monies recovered from the forfeiture of curing payment, the balance will be deducted from the remaining payment for concrete. Payment for concrete shall include cement.

Payment shall also include all costs associated with quality control.

Measurement of volume will be made to the surfaces shown on the drawings or ordered by the Ministry Representative. Deductions will be made of the volumes of embedded ducts, timbers, etc., but not of the volume of reinforcing steel. No payment will be made for concrete placed outside the surfaces shown or ordered, as to fill spaces left by over excavation or irregularities in excavation. The reduced price to be paid for understrength concrete shall be calculated by the following formula:

$$P_R = \frac{S_{AV}}{S_{SP}} \times P_U$$

Where

P_R = reduced price

P_U = bid price

S_{SP} = specified strength

S_{AV} = the lowest average of three consecutive strength tests for one classification of concrete within the same structural element. Where less than three strength tests are taken, the results shall be the average of all the actual strength tests taken.

See SS 211.09.07 for circumstances under which a reduced price will be paid. Where a reduced price is paid, it will be applied to all of the concrete in the applicable pay item.

SURFACE EVAPORATION RATE

SP211-01

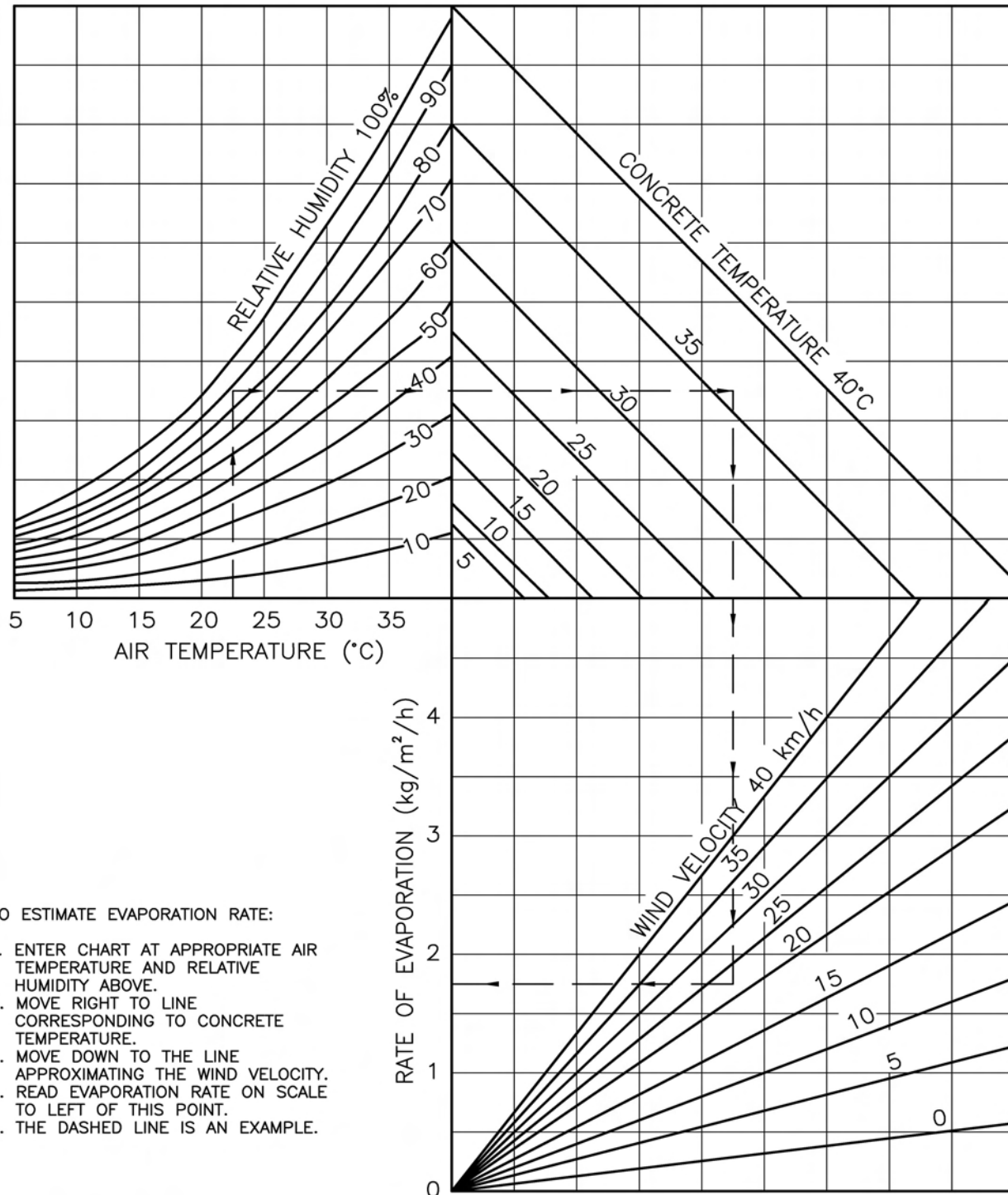

TO ESTIMATE EVAPORATION RATE:

1. ENTER CHART AT APPROPRIATE AIR TEMPERATURE AND RELATIVE HUMIDITY ABOVE.
2. MOVE RIGHT TO LINE CORRESPONDING TO CONCRETE TEMPERATURE.
3. MOVE DOWN TO THE LINE APPROXIMATING THE WIND VELOCITY.
4. READ EVAPORATION RATE ON SCALE TO LEFT OF THIS POINT.
5. THE DASHED LINE IS AN EXAMPLE.

THIS PAGE IS LEFT INTENTIONALLY BLANK

SECTION 213

TIMBER BRIDGES - CONSTRUCTION

213.01 Materials - All materials shall be of the quality, grade and finish as specified and shall conform to the relevant requirements of SS 903, SS 904, SS 905, SS 906 and SS 908.

213.02 Logs for Cribs and Log Stringers - Logs for cribs shall be cut from live trees and shall be peeled before use.

Stringers shall be cut from live trees not less than 30 days before use and shall be seasoned with the bark on. Immediately before use, all bark shall be peeled and the log trimmed smooth of all knots and projections.

213.03 Work Practice - The standard of work shall be first-class throughout and in accordance with AASHTO LRFD Bridge Construction Specifications, Second Edition 2004 with 2007 Interim Revisions.

213.04 Handling and Storing Materials - All materials shall be handled with reasonable care to prevent damage such as puncture, cutting or crushing of fibre.

Dogs, hooks, peavies or other equipment shall not be used on the side surfaces of treated timber. All handling of treated timber with pointed tools shall be confined to end grain and shall be such as to avoid damage of the original pressure-treated surface.

Subject to the approval of the Ministry Representative, the Contractor shall make good any superficial damage of treated timber by the methods outlined in the current edition of CSA, O80 Specification for Wood Preservation. Timber which, in the opinion of the Ministry Representative, cannot be made good by such methods will be rejected.

Minor damage to untreated timber shall be repaired and severely damaged pieces will be rejected.

When unloading at the site of the work, the various pieces shall be sorted and stacked in such a manner as to require a minimum of rehandling before being placed in the structure.

Level ground cleared of snow, brush and weeds shall be provided for stacking the timber. The timber shall be placed on blocking to raise it above the ground. If green timber is to be stored for more than one week, it shall be stacked with spacers between layers and covered to prevent direct exposure to sunlight.

The Contractor shall make good, at the Contractor's expense, any damage to materials supplied by the Ministry after having taken delivery of same.

213.05 Framing - Framing shall be first class in every respect and performed by skilled workers only. No open

joints, blocking or shimming of joints will be allowed. Daps, gains and dove-tails in trestles, culverts, cribs, etc. may be finished with an adze, but all joints shall go together without pounding or excessive cramping up and have full bearing in contact.

Holes shall be bored with an auger to the sizes shown in Table 213-A.

Spikes that are likely to crack or unnecessarily damage the timber shall have holes bored 1/16" small.

213.06 Field Treatment - Unless so specified, treated timber shall not be cut or dapped except for cutting to length. Cut ends and specified cuts and daps of treated timber (except piles) shall be field treated in accordance with the requirements of CSA Specification O80.

The heads of all treated piles, after cut-off, shall be covered with alternate layers of hot roofing pitch and loosely woven fabric using four applications of pitch and three layers of fabric.

The fabric shall measure at least six inches more in dimension than the diameter of the pile and shall be neatly folded down and secured by large-headed galvanized roofing nails or by binding with not less than seven complete turns of galvanized wire securely held in place by large-headed galvanized roofing nails or staples. The edges of the fabric projecting below the fastening shall be neatly trimmed.

The heads of all untreated piles, after cut-off, shall be thoroughly swabbed with three coats of hot creosote oil and if they are to be capped, they shall also be coated with hot roofing pitch.

All bolt holes drilled in the field in treated timber shall be treated with hot creosote oil applied with an approved pressure bolt hole treater.

All surfaces in contact and all bolt holes in untreated timber shall be swabbed with a water-borne preservative.

213.07 Preparation of Laminated Decks for Wearing Surface

213.07.01 For Asphalt Plank - Depressions in laminated decks shall be levelled by placing and compacting a fine sand levelling course.

The levelling course shall consist of a mixture of fine durable sand conforming to the gradation shown in Table 213-B.

The sand shall be thoroughly mixed with asphalt emulsion, Type SS-1 which shall conform to the requirements of

SECTION 213

TIMBER BRIDGES – CONSTRUCTION

Subsection 952.08. The asphalt emulsion content shall be such that an air void content of 5% to 8% in the compacted mixture is obtained. This will normally require an asphalt emulsion of 15% to 25% by weight of the total mixture.

Before laying and nailing asphalt plank, laminated decks shall be swabbed with oxidized mopping asphalt Type 2 conforming to the requirements of Table 213-C.

213.07.02 For Asphalt - Prior to placing asphalt wearing surface, creosote-treated laminated decks shall be lime-scrubbed where creosote oil has "bled" to the surface.

To prevent "bleeding" of the creosote oil, the mix temperature of hot-mix asphalt placed on these decks shall be as low as is practicable.

213.08 Basis of Payment - Payment will be made at the unit prices bid, for the various items in the Schedule of Approximate Quantities and Unit Prices, for material remaining in and forming a part of the finished structure. Such payment shall be accepted as full compensation for all labour, equipment, tools, materials, including hardware and furnishing and placing all other items required to complete the work.

TABLE 213-A HOLE SIZES

	FIR AND HARD-WOODS	CEDAR AND SOFT-WOODS
BOLTS	1/16" Large	Same size as bolt
DRIFT BOLTS	Same size as bolt	1/16" Small
DOWELS	1/16" Large for ends of posts, but in sills make same size as dowel	1/16" Large for ends of posts, but in sills make same size as dowel

TABLE 213-B CONSISTENCY OF THE LEVELLING COURSE

U.S. STANDARD AND ASTM SIEVE SIZES	PERCENTAGE PASSING BY WEIGHT (%)
#8	100
#16	100 - 60
#30	80 - 46
#50	62 - 35
#100	46 - 25
#200	35 - 18

TABLE 213-C REQUIREMENTS FOR OXIDIZED MOPPING ASPHALT TYPE 2

TEST DESCRIPTION	ASTM TEST METHOD	TYPE 2	
		MINIMUM	MAXIMUM
Softening Point (R & B), °F	D 36	165	175
Flash Point, C.O.C., °F	D 96	450	---
Penetration @ 32°F	D 5	12	20
Penetration @ 77°F	D 5	20	35
Penetration @ 115°F	D 5	---	70
A.P.I. Gravity @ 60°F	D 71	4.6	5.8
Ductility @ 77°F, 5 cm minimum	D 113	3	---
Loss on Heating to 325°F, 5 hr., %	D 6	---	0.3
Penetration of Residue, % of original	D 5	80	0
Total Bitumen (soluble in CS ₂) %: Mineral Stabilized Asphalt	D 4	80	---
Total Bitumen (soluble in CS ₂) %: Asphalt Without Mineral Stabilizer	D 4	99	---

THIS PAGE IS LEFT INTENTIONALLY BLANK

SECTION 214

TIMBER PILING CONSTRUCTION

214.01 Materials - All piling shall conform to requirements of SS 906, Round Timber Piles, and where specified to SS 908, Preservative Treatment.

214.02 Pile Lengths - Piling shall be supplied to the minimum lengths specified. At the Contractor's expense, allowances will be made for such additional lengths of pile as may be required to provide fresh heading and to suit the Contractor's methods of operation.

Pile lengths determined by the Ministry, are those expected to remain in the completed structure plus 600 mm for cut-off, except for end bearing piles where the allowance for cut-off and bearing depth irregularity is 3.5 m.

214.03 Handling of Piles - The use of dogs, hooks, peavies or any other equipment which may damage the round surface of a treated pile will not be permitted.

Pointed tools used in the handling of treated piles shall be confined to end grain.

During lifting, long piles shall be supported at a sufficient number of points, properly located, to prevent damage due to excessive bending.

Subject to the approval of the Ministry Representative, the Contractor shall make good any superficial damage of treated piles by the methods outlined in the current edition of CSA O80 Specifications for Wood Preservation. Piles damaged by the Contractor, which, in the opinion of the Ministry Representative, cannot be made good by such methods, will be rejected and shall be replaced at the Contractor's expense.

214.04 Hammer - Piles may be driven with a drop hammer or a mechanical hammer. Drop hammers shall weigh not less than 1,400 kg for piles less than 15 m long and not less than 1,600 kg for piles 15 m and over in length, and in no case shall the weight of the hammer be less than the combined weight of driving head and pile. Mechanical hammers shall develop a total energy not less than 3,900 kg per blow.

214.05 Leads - Pile drivers with fixed leads or with hanging or swinging leads that can be held in a fixed position during driving shall be used to drive all piles.

Battered piles shall be driven using leads adaptable to their driving.

When driving treated timber piles, the use of spuds and chocks in the leads shall be kept to a minimum in order that the treated surface is not damaged.

214.06 Preparation for Driving

214.06.01 Driving Caps and Bands - The heads of timber piles, shall be protected by suitable driving caps of approved design, preferably having a rope or other suitable cushion next to the pile head and fitting into a casting which in turn supports a timber shock block.

Alternatively, the pile head may be banded with a pile ring and covered with a steel wire mat. When driving treated piles, a driving cap shall be used.

214.06.02 Pointing - Where soil conditions, in the opinion of the Ministry Representative, require the pointing of piles, the Contractor shall fit the piles with steel points.

If required, steel points shall be supplied and installed by the Contractor and fabricated in accordance with Drawing SP214-01.

214.06.03 Excavation - Footing excavation and seal excavation, where applicable, shall be completed with any necessary allowance made for upheaval before the driving of footing piles. Should too great an allowance be made, backfilling with gravel will, in general, be permitted to raise the bottom of the excavation to the correct elevation. Any material forced up between the piles to above the footing level shall be removed to the correct elevation. No extra payment will be made for the supply and placing of gravel or any additional excavation to obtain the correct elevation.

214.07 Driving - Unless otherwise specified, all piles shall be driven with the small end downward. The fall of a drop hammer shall be regulated to avoid damage to the piles and under no circumstances shall the drop exceed 3 m.

Each pile shall be square-headed, properly pointed, and set properly in the leads; if any pile becomes split or broomed on the top it shall be fresh headed.

Piles shall be driven to the minimum depth indicated on the Drawings or as otherwise specified and unless ordered otherwise by the Ministry Representative, to practical refusal, which shall be to the depth at which the piles have a load carrying capacity of 20 tonnes and an average penetration per blow determined by the following formulae:

For drop hammers:

$$s = \frac{wh}{6p} - 0.03$$

For mechanical hammers:

$$s = \frac{wh}{6p} - 0.003$$

Where: s = average penetration per blow in metres under last 10 blows
 w = weight of moving part of hammer in newtons
 h = effective fall of hammer in metres
 p = allowable load capacity of pile in newtons

Where it is required by the Ministry Representative to penetrate a thin stratum (which may show practical refusal in driving) to obtain greater depth in a less resistant formation, driving shall be continued through the stratum regardless of the definition laid down for practical refusal.

Any pile which, in the opinion of the Ministry Representative, is so damaged by driving so as to be deemed unfit for the use for which it is intended, or is so far out of position, or off vertical or designated batter, as to require excessive force or manipulation to restore it to its proper position, shall be withdrawn and replaced by a new pile. If this is not possible, a new pile shall be driven adjacent to the defective pile. The damaged, out-of-position or misaligned piles shall be for the Contractor's account.

Where boulders or other large obstructions make it impossible to drive piles in the locations shown on the Drawings, the Ministry Representative may direct the Contractor to drive an additional pile, or piles, for which the Contractor will be paid in accordance with the various Items of SS 214.12 - Payment.

214.08 Additional Equipment - Where, in the opinion of the Ministry Representative, the bounce of the hammer is excessive or where the required depth or resistance is not obtained by the use of a hammer complying with the above minimum requirements the Contractor shall provide a heavier hammer at the Contractor's expense.

214.09 Accuracy of Driving - All piles shall be driven in such manner that any variation from the vertical, or batter as shown on the Drawings, shall not exceed 20 mm/m. Piles in trestle bents shall be driven so that the cap may be placed in its proper location without incurring excessive stresses in the piles. Cutting, springing, dapping or facing-off for placing bracings and planking on piles will not be permitted.

After driving, footing piles shall not be more than 75 mm out of the position shown on the Drawings.

214.10 Pile Heads - The tops of all piling shall be cut off to a true plane as shown on the Drawings or as established by the Ministry Representative. Piles shall show a solid head at the plane of cutoff.

Pile heads not encased in concrete shall be protected as follows:

214.10.01 Treated Piles - After cut-off, the pile heads shall be covered with alternate layers of hot roofing asphalt and loosely woven glass fabric, using four applications of asphalt and three layers of fabric.

The fabric shall measure at least 150 mm more in dimension than the diameter of the pile and shall be neatly folded down and secured by large headed galvanized roofing nails or by binding with not less than seven complete turns of galvanized wire securely held in place by large-headed galvanized roofing nails or staples. The edges of the fabric projecting below the fastening shall be neatly trimmed.

214.10.02 Untreated Piles - After cut-off, the pile head shall be thoroughly swabbed with three coats of hot creosote oil and if they are to be capped, they shall also be coated with hot roofing asphalt.

214.11 Surplus Ministry Supplied Treated Piling - When treated piling is to be supplied by the Ministry, any surplus piling and pile cut-offs designated by the Ministry Representative for salvage shall be loaded, transported and unloaded by the Contractor at the conclusion of the pile driving operation. The location of the storage will be as specified by the Ministry Representative.

Payment for taking delivery, transporting and handling of surplus piling will be made as Extra Work.

214.12 Payment - Payment for timber piling construction will be made under the following Items:

- a) Setting up
- b) Handling
- c) Pointing
 - i) Supply
 - ii) Install
- d) Driving

214.12.01 Payment for Ministry Supplied Piles - When piling is supplied by the Ministry free to the Contractor, payment will be made as follows:

Payment under item (a) will be made at the Lump Sum price bid for providing, setting up and removing the plant and equipment for driving the piles, and shall be accepted as full compensation for everything furnished and done in connection therewith.

Payment under items (b) and (c) will be made at the Unit Price bid per pile or pile point for the total number of piles or pile points remaining in and forming part of the completed structure, except that only piles and pile points called for on the Drawings or ordered by the Ministry Representative will be paid for. Payment shall be accepted as full compensation for all cost in connection with taking delivery, transporting, handling, and cutting off and treatment of piles or with supplying, handling and installing pile points. If pile points are not listed as an Item in the Schedule of Approximate Quantities and Unit Prices, but are ordered by the Ministry Representative, payment for (c) will be as Extra Work.

Payment for Item (d) will be made at the

Unit Price bid per metre for the total number of metres of piling remaining in the structure for those piles paid for under item (b).

Payment shall be accepted as full compensation for everything furnished and done in connection with the driving of piles.

214.12.02 Payment for Contractor Supplied Piles -

When piles are supplied by the Contractor, payment for supply will be made for under an additional Item, Supply and Delivery. Payment for Items (a), (b), (c), and (d) will be as specified in SS 214.12.01, except that Item (b) shall not include payment for taking delivery of the piles.

Payment for Supply and Delivery will be made at the Unit Price bid per metre for the total number of metres of piling as shown on the Drawings or as specified. Such payment shall be accepted as full compensation for everything furnished and done in connection with the supply and delivery of the piles.

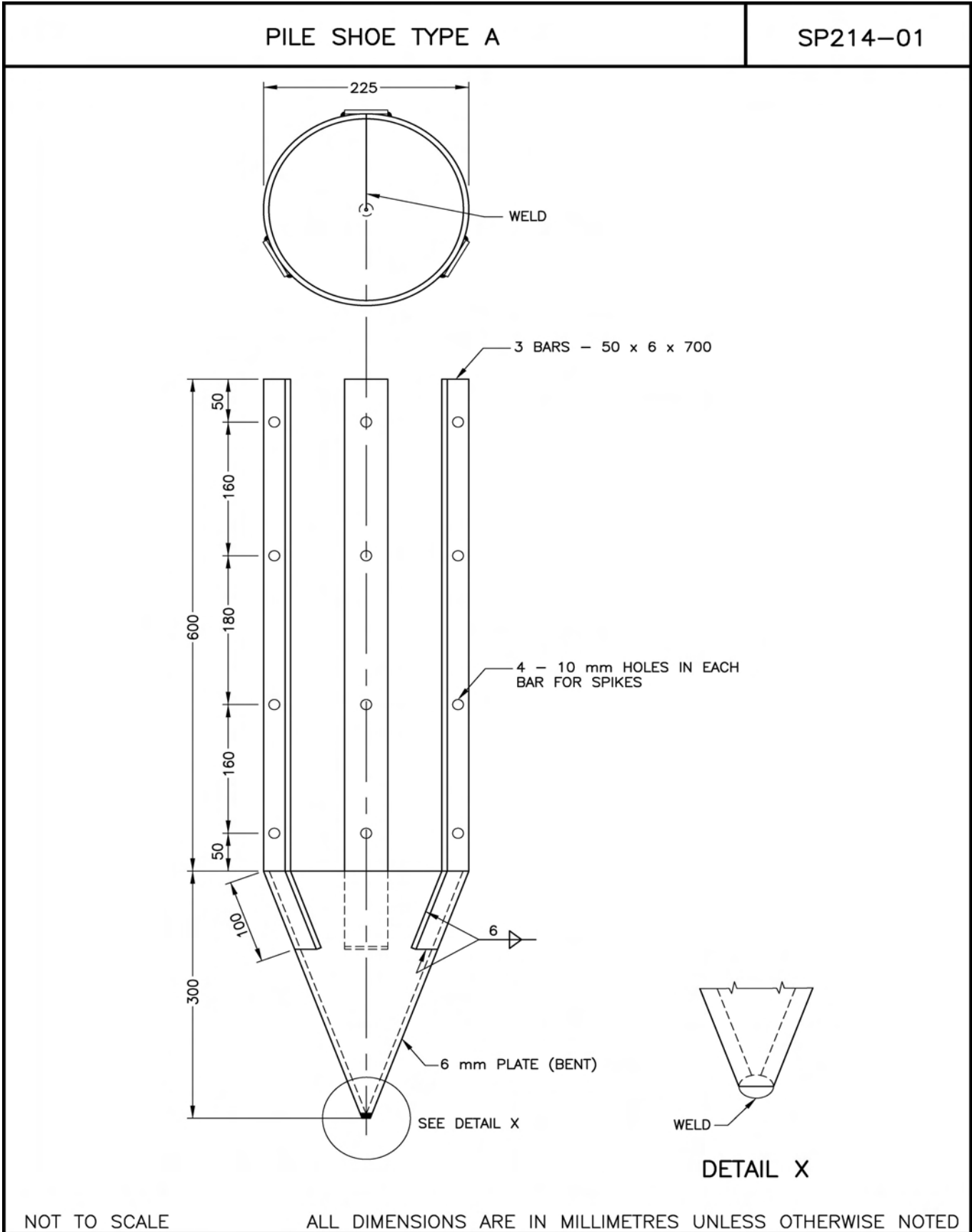

SECTION 215

BRIDGES

215.01 General - Bridges shall be designed in accordance with the Canadian Highway Bridge Design Code, CAN/CSA S6-06 and the Ministry's Supplement to CHBDC S6-06, Volume 1 of the Ministry's Bridge

Standards and Procedures Manual. Fabrication and erection shall be in accordance with the specifications prepared for the particular structure.

THIS PAGE IS LEFT INTENTIONALLY BLANK

SECTION 216

COATING OF STEELWORK

216.01 Scope - This Section covers the operations required for shop, field and/or maintenance coating of structural and miscellaneous steel surfaces. The coating process includes pre-cleaning, surface preparation, coating, and curing of coatings.

216.02 Definitions

216.02.01 Good Painting Practice - The application of generally accepted methods and equipment to clean, contain and coat industrial structures in a safe, practical, environmentally sensitive manner resulting in a long lasting quality protective coating system. These principals are laid out in this Section. Many of the points are drawn from the SSPC (Society for Protective Coatings) publication Steel Structures Painting Manual Volume 1, Good Painting Practice. References are to the current edition unless otherwise stated. These practices are based on experience in the United States and where they conflict with Canadian or British Columbia laws, regulations or guidelines, the local regulations shall prevail.

216.02.02 Shop, Field and Maintenance Coating - The series of operations that include the surface preparation, pre-treatment (if required) and application of coatings to structural steel surfaces either in the shop or in field. It also includes the supplying of all labour, equipment and materials. In addition, it encompasses the protection of newly coated surfaces during curing, transport and erection as well as the protection of traffic, property and the environment. Additionally, it also includes the disposal of waste material in accordance with all applicable environmental, fisheries and local regulations and bylaws.

216.02.03 Painting / Coating - The terms painting and coating are considered synonymous for the purposes of this document. Techniques such as metallizing or galvanizing while not typically thought of as painting, are considered here to be painting or coating since they form part or all of a protective system.

216.02.04 Shop Coating - The coating of steel or other components in a shop or plant before shipment to the site of erection. This may include part of a coating system or the whole system including the topcoat.

216.02.05 Field Coating - The coating of steel or components at the place of erection.

216.02.06 Maintenance Coating – The coating of structures in service that have previously been partially or completely coated. The maintenance coating may be one of four general types:

216.02.06.01 Touchup – The cleaning and coating of small selected areas on a structure. Typically, this is used to repair damaged or failed areas of coating. For repairs, sufficient coats are added to bring the new coating up to the level of the existing coating surrounding the repairs. It

may also be used as an interim maintenance strategy to extend the lifetime of a coating system overall.

216.02.06.02 Zone Coating – The coating process where specific whole parts of a structure are coated and others are deliberately left. This deals with larger portions of a structure than touchup coating. For example an above deck arch portion of a bridge would be zone coated, but the edges of the flanges would be touched up. Zone coating may use touchup, overcoat, or recoat strategies to meet its objectives. Zone coating also includes coating new steel added to old structures for example steel added for seismic upgrades.

216.02.06.03 Overcoating – The coating of portions of a structure where the structure is touched up, then coated with a topcoat overall. It may include top coating part or all of the structure.

216.02.06.04 Recoating – The coating process where larger portions of old coating on a structure are removed to bare metal and a completely new coating system is applied over the entire area.

216.02.07 Surface Profile - The surface profile is a measure of the roughness of the prepared surface. The profile is normally measured from surface peak to surface valley and expressed as a range (for example 50 to 75 μm or 2 to 3 mils). Besides the depth, the surface profile is dependant on the grit type used to create it. Mineral abrasives such as sand, slag, garnet, etc. produce a 'sharp' profile. Steel shot produces a rounded profile unless mixed with 15% steel grit. Normally the surface profile is specified for both depth and sharpness.

216.02.08 Containment / Hoarding - The process of encapsulating the work site so that hazardous or nuisance materials cannot escape to the surrounding environment. SSPC Guide 6 Guide for Containing Debris Generated During Paint Removal Operations specifies types and levels of containment necessary for various cleaning operations.

216.02.09 Ambient Conditions - Ambient conditions refer to such things as wind, relative humidity, dew point, air temperature, substrate temperature etc. that affect the cleaning, application, and curing of coatings. They are very important in obtaining a properly adhered, long life coating. All coating works shall be within the specified parameters as given in SS 216.08.04, SS 216.08.05 and SS 216.08.09. Where ambient environmental conditions do not fall within these conditions, coating work may continue if the conditions are being met within the containment. This may mean extra hoarding, dehumidification, ventilation and/or temperature control for the duration of cleaning, application and curing of the coating system.

It is worthy of note that some coatings are designed to apply in conditions outside those mentioned above. These coatings and their conditions of use will be individually considered for use.

216.03 Reference Standards - It is recognized that standards are changed or amended from time to time. All specifications mentioned shall be the current editions at the date and time of contract signing unless a specific edition of a reference or standard is stated here or in the Contract Special Provisions.

216.03.01 British Columbia Ministry of Transportation and Infrastructure

216.03.01.01 Recognized Products List (RPL) - The Ministry publishes a Recognized Products List of products. This is available on the Ministry website at:

http://www.th.gov.bc.ca/publications/eng_publications/geo_tech/Recognized_Products_Book.pdf

Only those coating systems and products listed under the heading of "Coating Systems" in the RPL or as otherwise specified in the Special Provisions or on the Drawings shall be used on Ministry Projects. The Ministry may, at its sole discretion, designate alternative materials to fit a unique situation.

216.03.02 SSPC - Society for Protective Coatings - The SSPC publishes two volumes: SSPC Painting Manual Volume 1, Good Painting Practice and SSPC Painting Manual Volume 2, Systems and Specifications, which lay out the basics for painting steel structures. The following SSPC standards and guidelines shall apply unless noted otherwise.

216.03.02.01 Surface Preparation Standards

216.03.02.01.01 General - SSPC-SP COM Surface Preparation Commentary for Steel and Concrete Substrates.

216.03.02.01.02 Visual Standards:

Guide to SSPC-VIS 1, Visual Standard for Abrasive Blast Cleaned Steel

Guide to SSPC-VIS 2 Standard Method of Evaluating Degree of Rusting on Painted Steel Surfaces

Guide to SSPC-VIS 3 Visual Standard for Power and Hand Tool Cleaned Steel

Guide to SSPC-VIS 4/NACE No. 7 Guide and Visual Reference Photographs for Steel Cleaned by Water Jetting

SSPC-VIS 5/NACE VIS 9 Guide and Reference Photographs for Steel Surfaces Prepared by Wet Abrasive Blast Cleaning

216.03.02.01.03 Surface Cleaning Standards:

SSPC-SP 1 Solvent Cleaning

SSPC-SP 2 Hand Tool Cleaning

SSPC-SP 3 Power Tool Cleaning

SSPC-SP 5/NACE No. 1 White Metal Blast Cleaning

SSPC-SP 6/NACE No. 3 Commercial Blast Cleaning

SSPC-SP 7/NACE No. 4 Brush-off Blast Cleaning

SSPC-SP 10/NACE No. 2 Near-White Blast Cleaning

SSPC-SP 11 Power Tool Cleaning to Bare Metal

SSCP SP 12/NACE No. 5 Surface Preparation and Cleaning of Steel and Other Hard Materials by High- and Ultrahigh-Pressure Water Jetting Prior to Recoating

SSPC-SP 13/NACE No. 6 Surface Preparation of Concrete

SSPC-SP 14/ NACE No. 8 Industrial Blast Cleaning

SSPC-SP 15 Commercial Grade Power Tool Cleaning

216.03.02.02 Abrasive Specifications:

SSPC-AB 1 Mineral and Slag Abrasives

SSPC-AB 2 Cleanliness of Recycled Ferrous Metallic Abrasives

SSPC-AB 3 Newly Manufactured or Remanufactured Steel Abrasives

216.03.02.03 Paint Application Standards, Guides and Specifications:

SSPC-PA COM Commentary on Paint Application

SSPC-PA 1 Shop, Field and Maintenance Painting of Steel

SSPC-TU 3 Overcoating

SSPC-PA 2 Measurement of Dry Film Coating Thickness with Magnetic Gauges

216.03.02.04 Guides:

SSPC - Guide 6 Guide for Containing Debris Generated During Paint Removal Operations

SSPC – Guide 12 Guide for Illumination of Industrial Painting Projects

216.03.02.05 Technical Updates:

SSPC-TU 4 Field Methods for Retrieval and Analysis of Soluble Salts on Substrates

SSPC-TU 6 Chemical Stripping of Organic Coatings from Steel Surfaces

SSPC-TU 7 Conducting Ambient Air, Soil, and Water Sampling During Surface Preparation and Paint Disturbance Activities

216.03.02.06 Qualification Procedures - These requirements will be laid out specifically in the Contract for each project and will depend primarily on the work to be done. Contractors may require current certification in one or more of the following levels to perform Ministry work as called for in the particular tender.

SSPC-QP COM Commentary on Qualification Procedures

SSPC-QP 1 Standard Procedure for Evaluating Painting Contractors

SSPC-QP 2 Standard Procedure for Evaluation Painting Contractors to Remove Hazardous Paint

SSPC-QP 3 Standard Procedure for Evaluating the Qualifications of Shop Painting Contractors

NACE Coating Inspection Program Level 2 with Peer Review

2.16.03.03 Hot Dip Galvanizing

CAN/CSA-G164, Hot Dip Galvanizing of Irregularly Shaped Articles

216.03.04 Metallizing

CAN/CSA-G189 Sprayed Metal Coatings for Atmospheric Corrosion Protection

216.03.05 Colour Standards - Refer to US Federal Specification 595B Colors. Topcoat colours shall be in accordance with the Special Provisions and/or the Drawings or as determined by the Ministry Representative.

216.04 Environmental Considerations

216.04.01 General - All coating works including preparation shall comply with SS 165, Protection of the Environment.

216.04.02 Environmental Agencies Affected - Depending on the Work, some or all of the following Environmental Agencies and other affected parties have interests and may need to be contacted for their input to the Work. The list below is not exhaustive.

216.04.02.01 Federal:

Fisheries and Oceans Canada

Environment Canada

Port Authorities

216.04.02.02 British Columbia:

Ministry of Environment (MoE)

Provincial, Municipal or Private Utilities if Affected

Railways if Affected

Aboriginal Bands if Affected

Water User Groups if Affected

Other Affected Parties, as necessary

The various parties' interests vary from legislated involvement to public or private interest in the portion of the environment potentially affected by the coating project. It is the Contractor's responsibility to liaise with all the affected parties and to meet the requirements of the relevant authorities.

216.05 Containment of Coating Operations

216.05.01 General - Full containment shall be provided to prevent contamination of the environment. This enables work to be accomplished by physically limiting the spread of debris and facilitates cleanup. Current containment technology is able to contain virtually all debris generated

by washing, water jetting, hand, power tool, or abrasive blasting, and coating operations.

216.05.02 SSPC - Guide 6 - Containment shall be provided in accordance with SSPC - Guide 6, Guide for Containing Debris Generated During Paint Removal Operations. In general, the Ministry wishes to minimize the environmental impact of all Ministry coating work. To this end, all coating works shall be fully enclosed to prevent contamination of the environment. The coating specification will contain specific language to exactly determine the desired containment end performance requirements. Containment shall be approved by the pertinent WCB, Environment and Fisheries Authorities.

216.05.03 Containment of Debris and Disposal of Debris - All debris from cleaning and coating operations must be contained in such a way as not to contaminate the environment. All debris shall be contained, tested and disposed of in accordance with current environmental, fisheries and local regulations. The Contractor shall provide written proof of disposal of all materials including way-bills and transport logs.

216.06 Construction Site Safety

216.06.01 General - General site safety is governed primarily by SS 135 Construction Site Safety. The Contractor shall also meet all WCB regulation requirements for work undertaken.

216.06.02 Specific Safety Issues Relating to Bridges and Coating Work

216.06.02.01 Working at Height - All work occurring at height shall conform to all WCB regulation requirements.

216.06.02.02 Lead Paint - Many of the Ministry structures are painted with paint containing lead. While the Ministry will attempt to indicate the presence of paint containing lead, it is the responsibility of the Contractor to ascertain the presence and extent of lead containing paint if any; and to conform to all regulations for work undertaken. This includes but is not necessarily limited to WCB and MoE regulation requirements for working with, storing, transporting, disposing of and documenting any work process involving lead paint.

216.06.02.03 Enclosed Spaces - Many of the Ministry structures contain enclosed spaces or spaces that the WCB defines as enclosed spaces. In some instances the hoarding or containment is considered an enclosed space. It is the responsibility of the Contractor to ascertain whether or not a space is defined as an enclosed space and to adjust their work procedures to meet all regulation requirements.

216.07 Surface Preparation

216.07.01 General - The useful lifetime of a coating is extended by appropriate surface preparation prior to coating. The Ministry will define in its coating Contracts, the quality of surface preparation for a given area to be coated. Where this surface preparation differs from the coating manufacturer's recommended surface preparation,

the Ministry Contract specifications shall be considered correct, but in the case where the coating manufacturer's specification requires more stringent surface preparation, the Ministry Representative shall make the final decision.

Where surface preparation is not defined in the Contract, the manufacturer's specifications shall be used.

216.07.02 Washing

216.07.02.01 General - Washing is a procedure for removing surface contaminants including oil, grease, drawing and cutting compounds, soil, salts, etc. from either steel or coated surfaces. Removal of the contaminants shall be accomplished by the use of any one or a combination of the following: potable water, alkaline cleaners, solvents, emulsion cleaners, steam cleaning (with detergents), high pressure water, scrubbing (with detergent) or other approved method.

Alkaline cleaners, detergents, solvents, etc. shall not be used over streams, lakes, rivers, etc. or agricultural land without first obtaining approval from the Ministry of Environment (MoE) as well as Fisheries and Oceans Canada.

The washing procedure shall be conducted so that any part of the structure which has already been cleaned, or newly coated, shall not be contaminated with the cleaning chemicals or solvents.

Immediately after treatment with cleaning chemicals, the surfaces shall be thoroughly washed with clean water to remove detrimental residues.

216.07.02.02 Residual Ion Levels - One main reason for washing is to remove residual anions such as chloride and sulphate as well as the ferrous cation and other non-visible contaminants. Currently, low risk levels for most of the ions are not well defined, however chloride levels are. Generally levels shall be at or below the SSPC-SP12 NV-2 level, less than 7 µg/cm² chloride ion, 10 µg/cm² soluble ferrous ion, and 17 µg/cm² sulfate, immediately prior to application of coatings when tested by SSPC-TU 4 swabbing extraction method.

Chloride levels shall be measured using one of the methods in SSPC-TU 4, and calculated using the formula in Appendix C of that specification. Verification of NV-2 level shall be done prior to surface preparation operations and prior to primer application.

216.07.03 Water Cleaning/Jetting - Water jetting encompasses low pressure water cleaning (LP WC), high pressure water cleaning (HP WC), high pressure water jetting (HP WJ), and ultrahigh pressure water jetting (UHP WJ).

SSPC-SP12/NACE No. 5, Surface Preparation and Cleaning of Steel and Other Hard Materials by High- and Ultrahigh- Pressure Water Jetting Prior to Recoating defines specifications for visual and non-visual surface preparation by water jetting.

Water jetting is inherently dangerous and safety precautions as listed in SSPC-SP 12 and in SSPC Steel Structures Painting Manual, Volume 1, Good Painting Practice, shall be followed. Where current WCB regulations conflict with SSPC-SP12/NACE No. 5, the WCB regulations shall prevail. Water used in water jetting units shall be clean and free of contaminants that may leave deposits on the surface being cleaned or affect the adhesion of subsequent coatings applied. Water supply to the water jetting units must meet regulations for water taken from streams if on-site water from streams is used.

All waste water and coating debris shall be contained and disposed of in accordance with Environmental and Fisheries Agencies or other applicable regulations.

Wastewater must meet regulations for disposal on-site if it is to be disposed of on-site. These regulations are typically those of Fisheries and Oceans and MoE, but may not be limited to those governmental agencies. As well, SS 165 Protection of the Environment, lays out Contractor responsibilities.

216.07.04 Manual and Power Tool Cleaning - Manual cleaning is a procedure for removing loose mill scale, loose rust, loose coating and other detrimental foreign matter by chipping, scraping, grinding, and wire brushing, etc. The tools used for this method of cleaning may be either hand or power tools; they shall be of high quality, and maintained in good repair.

The standard of cleaning obtained by this method shall be SSPC-SP 2, SP 3, SP 11 or SP 15 as specified in the Contract. Where surface preparation is not defined in the Contract, the manufacturer's specifications shall be used.

In specific circumstances the methods available may be limited by the Contract.

In all four preparation methods listed above, the surface shall be cleaned of dirt, grease and soluble salts prior to treatment. Heavier layers of rust shall be removed by chipping, before any of the other cleaning tools are used.

Finally, all traces of dust shall be removed prior to coating.

216.07.05 Abrasive Blast Cleaning - Abrasive blast cleaning is a procedure for removing mill scale, rust, rust scale, paint or other foreign matter by use of abrasives propelled through nozzles or by centrifugal wheels. It is also used to roughen the surface of the substrate to enhance adhesion.

If compressed air blasting is employed, proper line filters and dryers, which remove all oil and water from the air, shall be used. Compressed air shall be periodically tested for presence of these contaminants.

The standard of cleaning obtained by this method shall be SSPC SP 5, SP 6, SP 7, SP 10, or SP 14.

In all preparation standards, it is assumed that prior to treatment the surface has been cleaned of dirt, oil, grease and soluble salts etc. If necessary, heavier layers of rust

shall be removed by chipping before the blast cleaning operation commences.

A cleaned and blasted surface shall be coated within a maximum of 8 hours of cleaning and before the surface shows evidence of rust blooming. If either of these criteria is not met, then the surface shall be re-prepared to specification. If a prepared surface is contaminated before coating, it shall be re-cleaned and/or re-blasted to Contract Specifications before any coating is applied.

Finally, all traces of dust and sand, etc. shall be removed prior to coating.

216.07.06 Abrasive Materials - Abrasive materials, unless specified, must be accepted by the Ministry Representative.

216.07.07 Recycled Steel Abrasive - Recycled steel abrasives are permitted, however the working material must meet SSPC-AB 2 requirements and must contain a minimum 15% steel grit to produce an angular/sharp profile.

216.07.08 Containment of Debris and Disposal of Debris - All debris from cleaning and coating operations must be contained in such a way as not to contaminate the environment. All debris shall be contained, tested and disposed of in accordance with current environmental, fisheries and local regulations. The Contractor shall provide written proof of disposal of all materials including way-bills and transport logs.

216.08 Application of Coating Materials

216.08.01 Pretreatment - Newly cleaned surfaces may require pretreatment other than washing or abrasive blasting prior to the application of the prime coat of paint. The application of the pretreatment shall be strictly in accordance with the manufacturer's directions. When pretreatments are used, particular care shall be taken to prevent contamination of adjacent surfaces.

216.08.02 General - In general, the Contractor shall follow SSPC-PA 1 Shop, Field, and Maintenance Painting of Steel when applying coatings. Where SS 216 and SSPC-PA 1 disagree, SS216 shall be taken as applicable.

216.08.03 Materials Storage and Handling - Materials handling and use shall be as per SSPC-PA 1, 5.01. Coatings shall be stored in a secure building on-site, but not on the structure itself. Coatings taken onto the structure in cans, pails or totes shall be contained so that should they spill, no coating will escape to contaminate the adjacent area or environment.

216.08.04 Temperature - Coatings shall only be applied when the ambient, surface or coating temperature is within the range indicated by the Manufacturer's written instructions. Coating shall not be applied when the substrate temperature is less than 3°C above the Dew point. Winter or quick dry catalysts or coating formulations shall not be used. Some coatings are designed for use in marginal conditions. Their use is at the

sole discretion of the Ministry Representative. In unique situations where coatings must be used outside these limits, they shall only be used at the sole discretion of the Ministry Representative. Lack of permission may necessitate removal, re-cleaning and reapplication at the Contractor's expense.

216.08.05 Humidity - Coatings shall not be applied in wet weather, fog, mist, rain, snow and/or relative humidity in excess of 85%. Coatings shall not be applied to wet or damp or icy surfaces and care shall be taken to ensure that any overnight dew has completely evaporated before coating commences in the morning. Some coatings are designed to cure in higher humidity environments and may be specified on individual Ministry Projects.

216.08.06 Mixing and Thinning - All ingredients in any container of paint shall be thoroughly mixed before use and shall be agitated often enough during application to keep the paint in a uniform condition. In all cases of heavily pigmented paints (e.g. "Zinc Rich" paints) the material shall be continuously agitated during application.

Mixing shall be done in accordance with the manufacturer's instructions and in accordance with good painting practice as outlined in SSPC Steel Structures Painting Manual, Volume 1, Good Painting Practice and SSPC-PA 1.

Thinner shall only be added with the written consent of the Manufacturer and only after it is shown that satisfactory application cannot be obtained with proper adjustment of the spray equipment and air pressures. In no case shall more than 12.05% of thinner by volume be added to a paint.

Only thinner specified and supplied by the Manufacturer for that product shall be added to a product. Thinners used for cleanup shall not be recycled as thinning agents. Paint shall be mixed by mechanical methods. Paint shall be mixed in a manner that will ensure breaking up of all lumps, complete dispersion of settled pigment and a uniform composition. After mixing, all paint shall be strained to remove skins and other undesirable matter; the strainer shall not be so fine as to remove any pigment.

Thinner, when approved, shall be added after initial mixing is completed. The quantity of thinner added shall be measured in and thoroughly mixed until the paint is again of uniform consistency.

216.08.07 Induction Time - Manufacturers' induction times shall be strictly observed before the coating is applied. Since induction times are a function of temperature, temperatures outside the normal range may necessitate changing the induction period. Revised induction times may be accepted by the Ministry Representative, subject to the Coating Manufacturer providing the revised induction times in writing.

216.08.08 Pot Life - Manufacturer's estimates of pot life shall be adhered to and no coating shall be used after the recommended pot life has expired.

Since pot life is a function of temperature, in hot or cold conditions the pot life may have to be modified to reflect that temperature. Revised pot life times may be accepted by the Ministry Representative subject to the Coating Manufacturer providing the revised pot times in writing .

216.08.09 Wind - Paint shall not be sprayed when the wind speed is over 15 km per hour. This includes gusts. Wind speed shall be measured where the work is taking place, for example within the containment.

216.08.10 Curing Conditions - Coating lifetime may be affected by curing conditions. Coatings shall be protected from rain during their curing. Coatings shall be cured under the Coating Manufacturer's stated conditions. This may require heating, cooling, humidity or ventilation adjustments to bring the ambient conditions into line with the Coating Manufacturer's recommended conditions for curing. In enclosed spaces, ventilation must be provided to remove evaporating vehicle from the coating.

Failure to achieve proper curing or curing conditions may necessitate removal, re-cleaning, reapplication or repair of the coating at the Contractor's expense.

216.09 Inspection

216.09.01 General - The Contractor shall provide the quality control functions on the Contract work. Quality assurance will be done by the Ministry. The Contractor shall produce a quality plan for all work to be done and submit this plan for the Ministry's acceptance. The Ministry will audit the quality process via the Ministry Representative.

216.09.02 Quality Control Inspection - Quality Control inspectors shall be qualified NACE Level 2 plus peer review, i.e. NACE Certified Coating Inspectors. Inspection records produced shall be quickly forwarded to the Ministry Representative. The records shall be electronic files, preferably Microsoft Excel files, and shall be forwarded to the Ministry Representative in that format to speed dissemination and aid any data manipulation required for the quality audit. Where this is not possible due to lack of communication technology, the records may be hard copy or hand delivered electronic files. The Quality Control inspector(s) shall follow the quality plan as accepted by the Ministry.

All washing and cleaning work shall be inspected by the Contractor before any coating is applied. Each coat of paint shall be inspected by the Contractor and passed before the succeeding coat is applied.

Coated surfaces rejected shall be made to comply with all requirements of this specification at the sole expense of the Contractor.

216.09.02.01 Hold points for inspection shall include, but may not be limited to:

- Installation of scaffolding and other accesses
- Installation of containment

- Surface after washing
- Surface after cleaning prior to coating application
- Surface after Prime coat
- Surface after Penetrating Sealer if any
- Surface after Stripe Coat
- Surface after each midcoat
- Surface after caulking
- Surface after topcoat
- Removal of containment
- Removal of scaffolding and other accesses

216.09.02.02 Accessibility for Inspection - The Contractor shall provide the Ministry Representative safe access to the specific areas of the jobsite under inspection. In order to limit the work disruption, the Contractor shall notify the Ministry Representative of upcoming hold points at least 24 hours prior to the hold point. The Ministry may perform quality assurance and /or quality audit inspections in conjunction with or subsequent to the Contractor's quality control inspections. The Ministry Representative will attempt to limit delays to the Contractor as much as possible, but retains the right to obtain as much information from the quality assurance/audit inspections as needed to justify acceptance or rejection of the work.

The Contractor shall maintain a minimum 200 foot-candles illumination at all areas of the work to be inspected. This may include adding lighting to augment natural light. Lighting if added shall be according to SSPC Guide 12, Guide for Illumination of Industrial Painting Projects.

216.09.03 Thickness Measurement - Large areas amenable to the application of SSPC-PA 2 Measurement of Dry Paint Thickness with Magnetic Gauges shall be measured by this method. The use of PA 2 is not considered to limit the number of measurements should additional readings be needed for any reason.

The Contractor shall set aside a suitable area of steel on the structure to be coated and dry abrasive blast clean the area with the Contractor's equipment and blast abrasive to the standard required by the coating specification. This area shall be protected from moisture and shall be used as a standard for acceptable surface cleanliness and anchor profile. A portion of the area shall also be used as an area to verify the calibration of dry film thickness (DFT) gauges. It is recognized that the magnetic plane on the blast cleaned surface is above the bottom of the profile. The Contractor shall fill that difference with coating. If requested by the Ministry Representative, the Contractor shall produce and calibrate a secondary, portable calibration standard for dry film thickness gauges. The dry film thickness of small and/or more complex areas shall be measured as agreed upon by the Contractor's Inspector and the Ministry Representative. Gauges are to be calibrated

according to SSPC-PA 2 at the beginning and end of each work shift.

216.09.04 Tinting Multilayer Systems - Each separate coat, penetrant, stripe, midcoat(s) and topcoat shall be coloured or tinted to differentiate it visually from the coats above and below. This is an aid to application and inspection and also serves as an indicator of wear for the life of the coating.

216.09.05 Coating Systems - SS 308 lists coating systems used or identified by the Ministry and suggests situations where the systems are best applied. Coating systems meeting SS 308 requirements are listed in the Recognized Products List. Only specified coating systems from the Recognized Products List shall be used.

Occasionally, special requirements mandate the use of coating materials not already listed in SS 308. These requirements will normally be specified in the Contract Special Provisions section or will be shown on the Contract Drawings.

216.09.06 Coatings from Different Manufacturers - The Contractor shall not mix or interchange coatings or solvents from different manufacturers.

216.09.07 Coating Flaws - A coat of paint will only be accepted if none of the following faults are apparent:

- Coatings showing sags, runs, holidays, pinholes, orange peel, dry spray, shadowing or other application defects.
- Poor coverage at rivet heads, bolts, threads, plate edges, crevices, pockets, corners or re-entrant angles.
- Surfaces damaged mechanically by moving scaffolding, equipment, etc. or damage by rain, flying dust, etc. or damage from any other cause.

Sags and runs may be repaired or treated as per SSPC-PA 1, Section 7.04.05

Coatings shall be applied as per SSPC-PA 1, except where directed otherwise by this specification.

216.09.08 Rejection - Areas not meeting specification shall be repaired at the sole expense of the Contractor. At the sole discretion of the Ministry Representative, small areas may be spot repaired. Larger areas shall be re-cleaned to specification and the coating built up again to specification.

216.10 Application Methods (Excluding metallizing and Hot Dip Galvanizing)

216.10.01 General - Coatings are designed to be applied by specific application techniques. These techniques are specified by the Manufacturer to ensure that the risk of failure is minimized. Manufacturer's product application sheets shall be followed when applying coatings.

Where an application method is not possible due to circumstances at a particular structure, the Contractor shall obtain written instructions from the Manufacturer for a

new application method. Contractor use of the new application method is subject to approval by the Ministry Representative.

216.10.02 Brush or Roller Application - Brushes or rollers shall be of high quality and of a style and material that will enable proper coating application. The paint shall be brushed or rolled so that there are no runs or sags, minimum brush marks and a uniform thickness. Achieving the specified thickness for a coating may require more than one coat with brush or roller. The Contractor is responsible for achieving the specified thickness.

216.10.03 Air Spray Application - The equipment shall be capable of properly atomizing the paint to be applied. The equipment shall be kept clean and maintained in excellent condition. Equipment that has dirty or malfunctioning parts shall not be used until the parts are cleaned, repaired or replaced as necessary.

Paint shall be applied in a uniform layer, with overlapping at the edge of the spray pattern. The spray pattern shall be adjusted so that the paint is deposited uniformly. During application, the gun shall be held perpendicular to the surface and at a distance that will ensure that a wet layer of paint is deposited on the surface. The trigger of the gun shall be released at the end of each stroke.

All runs and sags shall be brushed out immediately, or the paint shall be removed and the surface repainted.

Areas inaccessible by spray such as cracks and crevices and the blind sides of rivets and bolts shall be painted by brush. Stripe coat material may be applied by spray to speed up the transfer of material to the surface, but all stripe coating must be brushed in to ensure complete wetting and coverage.

The air caps, nozzles and needles shall be those recommended by the manufacturers of both the material being sprayed and the equipment being used.

Proper air line filters and dryers shall be provided to remove oil and condensed water from the air. The air from the spray gun impinging against the surface shall show no condensed water or oils.

The pressure on the material in the pot and of the atomizing air shall be adjusted for optimum spraying effectiveness. Both material and atomization pressures shall be controlled by suitable pressure regulators with gauges. The atomizing air pressure shall be high enough to properly atomize the paint, but not so high as to cause excessive fogging of paint, excessive evaporation of solvent or loss by overspray.

The air compressor used shall be of sufficient size to maintain the regulated air pressures constant at all times, irrespective of the amount of equipment that is being operated from the compressor.

216.10.04 Airless Spray Application - The equipment shall be capable of properly atomizing the paint to be

applied. The equipment shall be kept clean and maintained in excellent condition. Equipment that has dirty or malfunctioning parts shall not be used until the parts are cleaned, repaired or replaced as necessary.

Paint shall be applied in a uniform layer, with overlapping at the edge of the spray pattern. The spray pattern shall be adjusted so that the paint is deposited uniformly. During application, the gun shall be held perpendicular to the surface and at a distance that will ensure that a wet layer of paint is deposited on the surface. The trigger of the gun shall be released at the end of each stroke.

All runs and sags shall be brushed out immediately, or the paint shall be removed and the surface repainted.

Areas inaccessible by spray such as cracks and crevices and the blind sides of rivets and bolts shall be painted by brush. Stripe coat material may be applied by spray, to speed up the transfer of material to the surface, but all stripe coating must be brushed in to ensure complete coverage.

Fluid tips shall be of proper orifice size and fan angle, and fluid control gun of proper construction as recommended by the manufacturers of both the material being sprayed and the equipment being used.

The air pressure to the paint pump shall be adjusted so that the paint pressure to the gun is proper for optimum spraying effectiveness. The pump pressure shall be controlled by a suitable regulator with working gauges.

Pressures higher than that necessary to properly atomize the paint shall not be used.

The air compressor used shall be of sufficient size to maintain the regulated air pressure to the pump constant at all times irrespective of the amount of equipment being operated from the compressor.

Proper filters shall be provided in the high pressure line so that dirt, dry paint or other foreign materials are not deposited on the paint film.

The trigger of the gun shall be pulled fully open and held fully open during all spraying to ensure proper application of paint. The trigger shall be released at the end of each stroke.

216.10.05 Mitt and Dauber Application - Mitt and dauber application shall be limited to situations where other coating application methods are poorly suited. Their use shall be at the sole discretion of the Ministry Representative.

Coating thickness shall be uniform over the entire surface of the object coated. Coating shall be free of pinholes or other holidays, sags, etc.

216.10.06 Powder Coatings - Powder coatings are finely ground coatings that are electrostatically sprayed onto the substrate, then melted into a consolidated layer by heat. Coatings may be thermoplastic or thermosetting. Cleaning is typically in a series of chemical baths.

Substrates contaminated with soluble salts shall be washed to remove those salts before being cleaned to meet specification. Acceptable levels of soluble salts shall be at the NV 2 level as stated in SSPC-SP 12.

The substrate to be coated shall be cleaned to the coating manufacturer's specifications. The water test shall show a clean surface.

If required for adhesion, a conversion coating shall be applied to the substrate before powder coating.

Fresh and reclaimed powder shall be dry, free flowing, and free of lumps and contaminants.

Soaking oven temperatures and residence times shall be sufficient to completely melt the powder, but not enough to oxidize or discolour the coating.

Coating thickness and gloss shall be uniform over the entire surface of the object coated. Coating shall be free of pinholes or other holidays.

216.11 Application Methods (Metallizing and Hot Dip Galvanizing)

216.11.01 Metallizing - Metallizing shall be applied in accordance with CSA-G189

Metallizing includes the thermal spraying of zinc or Zn:Al/85:15 alloy onto a properly prepared metal substrate.

The method of heating the spray metal is either by flame or by plasma arc. Spray metal may be in wire or powder form to fit the apparatus used to spray the metal. The application method shall ensure that a uniform, clean, well adhered, film of metal is applied to the steel surface.

Surface preparation shall be SSPC SP5 white metal blast. Profile shall be sharp, 50 to 75 µm.

Metallizing shall be applied by qualified personnel with documented field experience metallizing steel structures such as bridges.

Metallizing shall be applied in a uniform layer at a thickness of 150 to 200 µm thickness. For special applications, the thickness may be specified outside this range.

When the metallizing is to be overcoated to form a duplex system, the newly metallized surface shall be protected from contamination until coated. If the metallized surface becomes contaminated, the steel substrate shall be re-cleaned to SSPC SP5/NACE No. 1 as above and re-metallized.

Metallizing is porous, and application of a coating over the surface may require a mist coat or other special procedures to avoid bubbling and subsequent problems caused by the interaction of the porous coat with the coating being applied. This cost if any, shall be borne by the Contractor.

Metallizing may be applied over a much wider range of ambient conditions than normal paint. When application conditions may deviate outside normal coating conditions,

the Contractor shall consult the Ministry Representative for acceptance before proceeding.

216.11.02 Hot Dip Galvanizing - Hot dip galvanizing shall be applied in accordance with CAN/CSA-G164-M.

216.12 Application of Coatings

216.12.01 General - Application of coatings on steelwork specified to be painted as part of a Contract shall meet the following requirements.

216.12.01.01 Welding Requirements - Areas to be field welded shall have no paint applied for a distance of at least 100 mm back from the weld area.

If inorganic zinc primer is used, the set-back shall be a minimum 25 mm.

All welds shall be cleaned of weld residue including weld spatter and roughness on the welds. Sharp edges shall be rounded to a minimum radius of 1 mm.

All welds shall receive a stripe coat of midcoat material over the primer prior to the midcoat.

Welding done on existing coated surfaces shall have the coating removed, past the heat affected zone or 100 mm from the weld whichever is more, down to bare metal. Surface profile of the cleaned area shall be at least 25 µm (1mil).

216.12.01.02 Faying Surfaces - Unless specified otherwise, the faying surfaces of weathering steel shall be blast cleaned but not coated.

When faying surfaces are specified to be coated, faying or friction connections shall be coated with only a prime coat of a Class B certified coating. A copy of the Class B test certificate shall be supplied to the Ministry Representative for each coating used on a faying surface. The class of coating is as defined in CSA/CAN S6-06.

Coating and curing conditions shall strictly follow all application parameters listed on the Class B Certificate. Failure to do so will require re-cleaning and recoating according to the Class B parameters for that coating.

216.12.01.03 Surfaces Inaccessible After Erection - Surfaces inaccessible after erection shall receive the field coats of paint in the shop, before shipment to the erection site. Prior to erection, handling damage shall be repaired to the satisfaction of the Ministry Representative.

216.12.01.04 Application and Curing of Successive Coats of Paint - Each coat of paint shall be in a proper state of cure or dryness before the application of the succeeding coat. Unless otherwise specified a minimum of overnight drying shall be required. Under poor drying and curing conditions, this period will be extended.

Curing conditions shall be those given by the Coating Manufacturer in the product application instructions. Curing time will vary according to temperature and in some cases humidity. The required curing time is estimated at the ambient conditions during curing. This

will normally be done from data supplied by the Coating Manufacturer.

Coatings that have a maximum overcoating window shall not be overcoated after that time without appropriate surface preparation as provided in writing by the Coating Manufacturer. The overcoat window will be calculated from data supplied by the Coating Manufacturer using the ambient conditions at the site.

216.12.01.05 Primer - Primer shall not be applied until the cleaned steel surface meets specification requirements. Once specification requirements are met for a substrate, the primer must be applied within 8 hours. The substrate if protected will be assumed to continue to meet the specification for 8 hours unless obvious contamination has occurred. This will be at the sole discretion of the Ministry Representative.

Primer shall be applied to specification requirements. Should the specification requirements be different than the Coating Manufacturer's application instructions then the decision as to which is followed will be made at the sole discretion of the Ministry Representative.

216.12.01.06 Penetrating Sealers - Penetrating sealers or low viscosity products designed to wick into seams and seal them shall be applied according to the Coating Manufacturer's product data sheets unless the Contract calls for specific application parameters. Should that be the case, the sealer shall be applied to Contract specification requirements.

Current industry thinking has these products applied on top of a single primer coat and under stripe and midcoats.

Under certain circumstances it may be necessary to use a penetrating sealer as a primer or as a first coat. This will be at the sole discretion of the Ministry Representative.

216.12.01.07 Stripe Coat - All areas such as crevices, corners, rivets, bolts, nuts, welds, edges and other protrusions shall be given a stripe coat to ensure that there is sufficient coating dry film thickness. Unless it is specifically excluded, it is the intent of the Ministry that all such areas shall receive a stripe coat. Coating may be applied by spray, but it shall be brushed into all areas to be striped.

The stripe coat is a separate coat and shall be applied at the thicknesses given for the midcoat coating.

The stripe coat shall be applied to the area and at least 25 mm out from the area to be striped.

The stripe coat shall be a contrasting colour to the coats above and below it.

The stripe coat shall be cured before being overcoated.

216.12.01.08 Midcoat - Midcoat shall be applied as a full coat onto clean, cured, primer, sealer, and stripe coats. The stripe coat and or sealer shall be cured before being coated.

216.12.01.09 Caulking - Caulking shall be applied after the midcoat and prior to the topcoat.

Caulking shall be compatible with the coating system used. Silicone Caulking shall not be used.

Suitable caulking materials are listed in SS 308 under the sub heading System PCM Paint Caulking Materials.

Caulking shall be applied as specified in the Contract.

Caulking shall not be topcoated until it cures according to the Manufacturer's product data sheets. Lower temperatures may increase this time.

If there is a time window for top coating, the caulking shall be topcoated before the window expires.

216.12.01.10 Topcoat - Once the undercoat and caulking if any have cured, the topcoat shall be applied.

216.12.01.11 Lapping Existing Coatings - Primer if applied shall not overlap existing coatings by more than 10-20 mm. Ministry preference is that it just contacts the existing feathered coating or overlaps very slightly to seal the join.

Midcoat shall overlap existing coatings by a minimum 50 mm.

Topcoat shall overlap existing coatings by a minimum 50 mm and shall hide all newly added midcoat material.

216.12.02 Shop Coating- Unless otherwise specified the following procedure shall apply to all new steel prior to shipment to the site of erection:

Before blast cleaning, the steel shall be checked for contamination of non-visible salts and the surface shall meet SSPC-SP12/NACE No. 5, NV-2.

Before coating, the steel shall be blast cleaned to SSPC-SP 10/NACE No.02 Near white. Abrasive blast cleaning will be permitted prior to fabrication provided that any contamination incurred during fabrication is removed prior to coating, leaving an SSPC-SP 10/NACE No.02 surface. Small areas of contamination occurring during fabrication shall be cleaned by manual cleaning to SSPC-SP 3 Power tool cleaning and/or SSPC SP-12/NACE No. 5 LPWC as necessary to remove contamination. Large areas of contamination occurring during fabrication shall be dry abrasive blast cleaned again to SSPC-SP 10/NACE No.02 Near-white blast.

Surface profile for primers shall be 50 to 75 µm and sharp.

Prior to dry abrasive blasting, all welding slag, spatter and alkaline deposits in the vicinity of the welds shall be removed. Surfaces shall then be blast cleaned to SSPC-SP 10/NACE No.02 Near-white blast.

When fabrication is completed and the surfaces cleaned as required, they shall be inspected prior to the application of paint.

After passing inspection and before any contamination has occurred, the Contactor shall prime all steel surfaces with one coat of the selected shop coat primer from SS 308. Primer shall be applied to specification requirements. Should the specification requirements be different than the

Coating Manufacturer's application instructions then the decision as to which is followed will be made at the sole discretion of the Ministry Representative.

A dry abrasive blast cleaned surface shall be coated within 8 hours of cleaning and before rust blooming becomes apparent. If either condition is exceeded then the area must be re-blasted to specification.

Clean or partially coated steel shall be protected from contamination including, but not limited to dirt, oil, grease, soluble salts and overspray, while in the shop. Contaminated surfaces shall be re-cleaned at the Contractor's expense.

Surfaces that will be in contact with concrete shall be coated with the full system prior to erection. Coatings with known incompatibilities with high pH shall not be used in contact with the concrete.

Surfaces inaccessible after erection shall receive the field coats of paint in the shop, before shipment to the erection site.

If more than one coat is to be shop applied, manufacturer's recommended recoat times for the ambient temperatures shall be followed.

Generally, a minimum of 16 hours drying/curing time shall be required between the application of any paint in the shop and the moving or handling of any piece so painted. This period may be increased in cases where poor drying conditions exist, such as shop areas open to the weather in winter months. Since curing times vary with different coating products, variations from this time may occur with specific products.

Quick Dry/Cure products or products with "winter" catalysts shall not to be substituted for SS 308 products unless accepted by the Ministry Representative.

216.12.03 Transport of Coated Items - Transport of coated items shall be done in a manner that imparts minimum damage to the coating system.

The coatings shall be cured before handling and shipment.

Canvas or Fabric slings shall be used to move the items. Chains or other methods that are known to damage coatings shall not be used.

Coated items to be transported shall have sufficient dunnage to prevent coating damage. Transport tie-downs shall be padded to protect the coated surfaces and edges.

Transport damage shall be repaired at the Contractor's expense.

216.12.04 Field Repair of Damaged Shop Coating and Field Weld Areas - After the complete erection of shop coated steel members the following procedure shall apply:

Before coating, field weld areas shall be ground off to remove all welding slag, spatter and alkaline deposits in the vicinity of the welds. Washing will be required when the shop coat or steel has been contaminated with air borne dirt, dust, salt, chemicals, etc., unless the steel shows

no visible contamination, and meets the SSPC SP-12/NACE No. 5, NV2 levels for non-visible contaminants. Surfaces shall then be cleaned to SSPC-SP 11 Power Tool Cleaning to Bare Metal. The existing coating shall be feathered back 25 mm from damaged areas into good coating. Feathering shall continue until the existing coating is well adhered. This may be considerably more than the 25 mm feather back.

Care shall be taken not to damage surrounding areas.

Note: This cleaning shall include the 100 mm welding set back.

All field connections and all areas of the shop applied coating system damaged during handling, shipping and erection shall be cleaned to SSPC-SP 3 Power tool clean or SSPC SP11 Power tool cleaning to bare metal at the discretion of the Ministry Representative. Low pressure water cleaning shall be used as necessary to remove dirt, salts and other deleterious contamination.

All areas that have been cleaned to bare metal as required shall be coated with an organic zinc field primer, applied by brush to ensure full coverage. If the area is too large to coat practically with a brush, then spray may be used, providing overspray does not contaminate the surrounding finished coating.

Lapping of new and existing coatings shall be as SS 216.12.01.11 above.

If a partial system was applied in the shop then the primed areas shall be coated with successive coats to the level of the surrounding coating then the entire structure shall be topcoated. This treatment shall include a brushed-in stripe coat.

If a coating system was completely applied in the shop and on erection some damage has occurred or there are still uncoated areas, then these areas shall be cleaned per this section above and successively coated with each coat of the system up to the topcoat including a brushed-in stripe coat. Manufacturer's recoat times for the ambient temperatures shall be followed.

216.12.05 Field Coating - Remaining coats shall be applied as per SS 216.12.05.

216.12.05.01 Touch-up coating This section deals with the repair of small areas of coating. The definition of small areas, will vary depending on the situation, but in general, will apply to areas that can be economically treated using the touch-up technique.

The coating used for touch up and repair shall be one of the SS 308 Field Overcoat (FO) systems.

The area to be repaired and coated shall be washed to SSPC SP-12/NACE No. 5, WJ-4, with a surface cleanliness of NV-2 before attempting further cleaning. Areas of the coating that have failed or rusted shall be cleaned to SSPC-SP 3 or SSPC-SP 11 using the appropriate tools.

The old coating shall be feathered back 25 mm from damaged areas into good coating. Feathering shall continue until the coating is well adhered. This may be considerably more than the 25 mm feather back.

Pack rusted crevices will require more thorough cleaning. The degree of cleaning required will be detailed in the Contract Documents for each specific structure. After cleaning, they shall be coated with the prime coat, then a brush coat of penetrating sealer shall be applied to the crevice and allowed to soak in. Repeated applications of the penetrating primer may be necessary until the inside of the crevice is saturated. Where the coating system used does not include a specific primer coat, the penetrating sealer shall be applied as a first coat.

In general, coating used for touch up and repair shall be of the same type as those used initially. For example if the coating system to be touched up is an alkyd system, then alkyds are the coatings of choice. The coating to be used shall be subject to acceptance by the Ministry Representative or as specified in the Contract.

The selected primer shall be applied in the damaged areas. The primer shall be cured for the time recommended by the manufacturer prior to additional coating being applied

After the primer is cured, the midcoat(s) shall be applied to bring the surface of the coating to the same level as the surrounding sound coating. The midcoat shall be applied within the manufacturer's suggested range of thickness. The midcoat(s) shall be cured for the time(s) recommended by the manufacturer.

After the midcoat material is cured, the area shall be given a topcoat. Where practical, the topcoat shall be extended to a logical edge such as the edge of the beam or plate, to present a less patchy appearance.

Lapping of new and existing coatings shall be as SS 216.12.01.11.

216.12.05.02 Overcoating - The object is to clean the surface, repair spot or area damage with coatings and to overcoat the entire area with a topcoat.

The coating used for touch up and repair shall be one of the SS 308 Field Overcoat (FO) systems.

The area to be repaired and coated shall be washed to SSPC SP-12/NACE No. 5, WJ-4, with a surface cleanliness of NV-2 before attempting further cleaning. Areas of the coating that have failed or rusted shall be cleaned to SSPC-SP-3 or SSPC-SP-11. Larger failed areas shall be cleaned to SSPC-SP 6/NACE No.03 Commercial blast clean. In this case, surface profile should be 50-75 µm and sharp.

Debris contaminating the rest of the structure or the immediate environment due to cleaning operations shall be removed by the Contractor.

The old coating shall be feathered back 25 mm from damaged areas into tightly adhered coating. If the coating

SECTION 216

COATING OF STEELWORK

cannot be removed with a dull putty knife, it is considered tightly adhered.

Pack rusted crevices shall be cleaned as per SS 216.13.01 above.

Once all the existing damaged areas are built up to the level of the existing coating, the topcoat is applied over the entire area to seal the existing coating and all the repairs.

In general, coating used for overcoating shall be of the same type as those used initially. For example if the coating system to be touched up is an alkyd system, then alkyds are the coatings of choice. Use of an over wintered test patch is recommended to test compatibility. The coating to be used shall be subject to acceptance by the Ministry Representative or as specified in the Contract.

216.12.05.03 Recoating - The area to be recoated shall be washed to SSPC SP-12/NACE No. 5, WJ-4, with a surface cleanliness of NV-2 before attempting further cleaning. The entire area shall be blast cleaned to SSPCSP 6 Commercial blast clean. Note that some specialty coatings or coatings in some difficult applications such as immersion may require SSPC-SP 10/NACE No. 2 Near-white blast or even SSPC-SP 5/NACE No. 1 White metal blast.

Surface profile should be 50 - 75 µm and sharp.

The Contractor shall provide full containment of debris generated by the cleaning, coating and curing operations.

Debris contaminating the rest of the structure or the immediate environment due to cleaning operations shall be removed by the Contractor at his cost.

Sharp edges shall be radiused to 1mm.

216.12.05.04 Zone Coating - Zone coating may use any one of or a combination of touch-up, overcoating or recoating on limited areas of a structure.

216.12.05.05 Field Curing of Coatings - Each coating application shall be cured before it is coated over or exposed to weather or traffic.

Coatings inside enclosed spaces shall continue to be ventilated until dry or cured to ensure that they cure correctly.

Uncured coating shall be protected against damage from dust or other detrimental foreign matter. If necessary, coating shall be delayed until the cause of the dust, etc. has abated. Uncured coating shall be protected from the weather until cured. In some cases, this may include hoarding, heating, ventilation or dehumidification. Coating contaminated or damaged by any of the above conditions shall be repaired at the Contractor's expense.

216.13 Damage to Adjacent Property - It is the intention of the Ministry of Transportation that the coating work shall have no adverse effect on adjacent property. Repair of damage to adjacent property, vehicles, pedestrians and other portions of the structure due to the Contractor's coating operations is the sole responsibility of the Contractor.

216.14 Cleanup - All construction and painting debris must be removed from the site and the site environs. The site and surroundings shall be left in the same condition as prior to work being commenced unless the specification directs otherwise.

216.15 Measurement and Payment - Measurement and Payment shall be as set out in the Contract Documents.

SECTION 218

CONCRETE FOR MINOR WORKS

218.01 General – The whole work shall be carried out in accordance with the best modern practice of cement concrete manufacture.

The Ministry Representative shall be the sole judge as to the suitability of the materials, their quantity, quality and condition; of the Contractor's plant, equipment and personnel; of the time and manner of carrying out the work and of every operation and matters incidental thereto.

218.02 Cement – Portland cement shall conform to CSA Standard A3000 – Cementitious Materials Compendium.

218.03 Aggregates – The aggregates shall be the best procurable and shall comprise inert, inorganic mineral matter only. They shall be satisfactorily clean, durable, hard, sound, strong and tough and be practically free from alkali, clay, dust, loam, mica, shale, silt or any material deemed objectionable in nature or amount by the Ministry Representative. None of the particles comprising the aggregates shall be coated nor be unreasonably flat or elongated. No aggregate may be used while frozen.

218.04 Grading of Aggregates – The grading of all aggregates shall be such as will produce an economic, plastic, practical, smooth, workable mix which when placed, set and cured, will produce a concrete of the best character possible.

To secure such grading, the Ministry Representative may require the Contractor to modify the aggregate by the addition or subtraction of proportions of specific sizes of material. The cost of making such modifications, by screening or otherwise, shall be included in the price bid by the Contractor.

218.05 Classes of Concrete – The classes of concrete are A, B, C, X and Y. Each class of concrete shall be used in that part of the structure in which it is called for on the Drawings, or where directed by the Ministry Representative. Unless otherwise specified, Class "A" Concrete shall be used. The following requirements shall govern unless otherwise shown on the Drawings:

Class "A" concrete shall be used for all superstructures, except as noted below, and for reinforced substructures except where the sections are massive and lightly reinforced. The more important items of work included are slabs, beams, girders, columns, arch ribs, box culverts, reinforced abutments and retaining walls, and reinforced footings. Class "A" concrete shall be used for precast piles and cribbing. Class "A" concrete shall also be used for work exposed to salt water.

Concrete deposited in water shall be Class "A" with 10% additional cement.

Class "B" concrete shall be used for mass footings,

pedestals, massive pier shafts and gravity walls with none or only a small amount of reinforcing.

Class "C" concrete shall be used for very massive unreinforced sections.

Class "X" concrete shall be used for massive sections lightly reinforced where a higher grade than Class "B" is desired.

Class "Y" concrete shall be used in thin reinforced sections, for handrails, except as specified, for precast railing under "Railings," and for filler in steel grid floors.

218.06 Classification and Proportioning of Concrete Mixtures – The materials shall be proportioned so that the amount of cement contained in 1 m³ of concrete in place shall be approximately as shown in Table 218-A.

The proportions of water, cement, coarse and fine aggregate to be used shall be determined by the Ministry Representative on the ground from time to time. Measurement shall be made by mass, and the accuracy must be satisfactory to the Ministry Representative; all such allowances for contained water, bulking or otherwise must be made as found necessary to allow for the proportions ordered by the Ministry Representative, being accurately provided in each batch.

218.07 Machine Mixing – The mixing of concrete, unless otherwise authorized by the Ministry Representative, shall be done in a batch mixer of type approved by the Ministry Representative. The mixer shall be equipped with a suitable charging hopper, water storage and water measuring device. It shall be cleaned at frequent intervals when in use and maintained in such a condition that the mixing action will be unimpaired.

218.08 Duration of Mixing – The mixing of each batch shall continue not less than 90 seconds after all the materials are in the mixer, during which time the mixer shall rotate at a speed of from 14 to 20 revolutions per minute unless otherwise rated by the manufacturer.

218.09 Hand Mixing – When hand mixing is authorized by the Ministry Representative, it shall be done on a watertight platform. The fine aggregate shall be spread on the platform and the cement spread evenly over the fine aggregate. The material shall then be shovelled into a cone shaped pile by casting centrally on the pile. This pile shall then be divided by casting into two or more cone shaped piles and the operation of dividing and reuniting continued until the batch is uniform in colour. Only sufficient water to produce the desired consistency shall then be added by sprinkling as the batch is turned. The coarse aggregate previously moistened shall then be mixed with the mortar in the manner specified for mixing fine aggregate and cement.

SECTION 218

CONCRETE FOR MINOR WORKS

218.10 Retempering – The retempering of concrete or mortar which has partially hardened, that is, remixing with or without additional cement, aggregate or water, will not be permitted.

218.11 Forms – Forms shall be so constructed that the finished concrete will conform to the shapes, lines, grades and dimensions indicated on the Drawings or as directed by the Ministry Representative.

Lumber used in forms shall be free from warp. For exposed surfaces, it shall be dressed to a uniform width and thickness and be free from loose knots, decay or other defects. For unexposed surfaces and rough work, undressed lumber may be used if means are taken to prevent leakage of mortar.

Lumber once used in forms shall have nails withdrawn and surfaces to be in contact with concrete thoroughly cleaned and smoothed before being used again.

Unless otherwise specified, suitable moulding or bevels shall be placed at the angles of forms to round or bevel the edges and re-entrant angles of the concrete.

For internal ties, bolts and rods shall preferably be used. They shall be so arranged that when the forms are removed no metal shall be within 25 mm of any exposed surface. Wire ties may be permitted only on light work; they shall not be used through surfaces where discolouration will be objectionable.

The inside of forms shall be coated with non-staining mineral oil, or other approved liquid or thoroughly wetted, (except in freezing weather). Where oil is used it shall be applied before the reinforcement is placed.

Care shall be taken to ensure that forms do not become dried and warped before concrete is deposited. Before

concrete is placed, forms and reinforcement shall be checked and approved by the Ministry Representative.

Forms shall not be disturbed until the concrete has adequately hardened. The proper time for removal of forms shall be determined by the Ministry Representative.

Care shall be taken when removing forms to avoid roughening or injuring corners and to keep edges sharp.

Whenever forms are removed from showing faces before the concrete has become hard and dry, the surface of the concrete shall be immediately wetted and kept wet for at least three days. Defects in showing faces shall be rectified to the satisfaction of the Ministry Representative.

218.12 Depositing Concrete – Concrete shall be deposited in forms in approximately uniform horizontal layers as near as practicable in its final position to avoid re-handling. Depositing shall be continuous until the unit of operation, as approved by the Ministry Representative, is complete and as rapid as practicable to ensure bonding of the successive layers.

Concrete shall be thoroughly worked around reinforcement and embedded fixtures and into all parts of the forms. Coarser particles shall be worked back from the face of the forms.

218.13 Basis of Payment – Payment shall be made at the prices bid per cubic metre of concrete and per kilogram of steel in place in and forming part of the finished structure; and in accordance with the various classes of concrete as defined in the specifications and as set out in the "Schedule of Approximate Quantities and Unit Prices"; and shall be accepted as full compensation for everything furnished and done in connection therewith.

TABLE 218-A CLASSIFICATION AND PROPORTIONING OF CONCRETE MIXTURES

CLASS OF CONCRETE	REQUIRED STRENGTH AT 28 DAYS MPa	SIZE OF COARSE AGGREGATE (mm)	CEMENT (kg) PER CUBIC METRE	MAXIMUM WATER CONTENT PER CUBIC METRE (ℓ)	MAXIMUM WATER/CEMENT RATIO
A	20	25.0 to 5.0	<u>365</u>	<u>191.0</u>	<u>0.52</u>
B	15	50.0 to 5.0	<u>280</u>	<u>171.5</u>	<u>0.61</u>
C	10	63.0 to 5.0	<u>225</u>	<u>168.0</u>	<u>0.75</u>
X	17.5	50.0 to 5.0	<u>370</u>	<u>221.0</u>	<u>0.60</u>
Y	20	20.0 to 5.0	<u>390</u>	<u>206.0</u>	<u>0.53</u>

TYPICAL RETAINING WALL

SP218-01

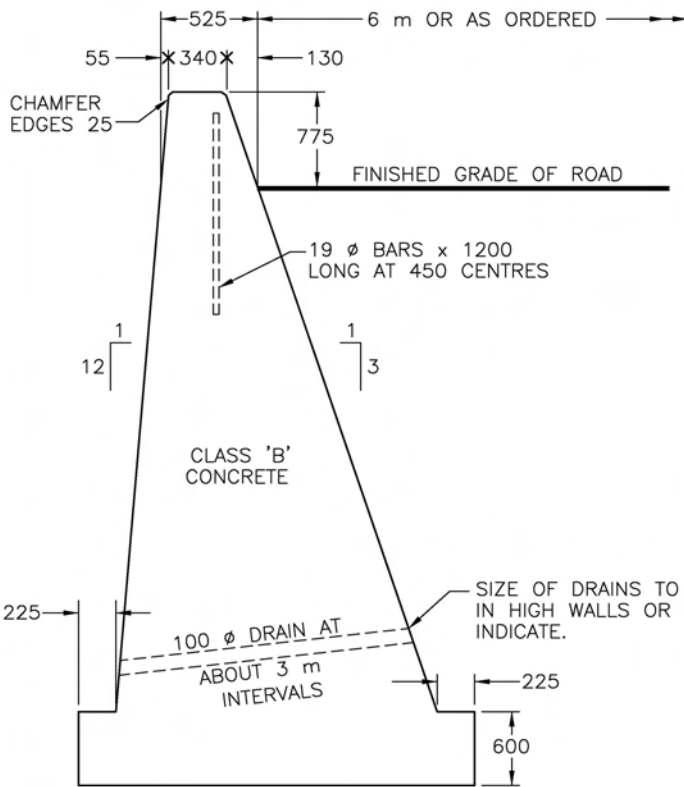

SECTION

BACKFILLING BEHIND THE WALL MUST BE DEPOSITED IN HORIZONTAL LAYERS, OR PREFERABLY IN LAYERS SLOPING AWAY FROM THE WALL.

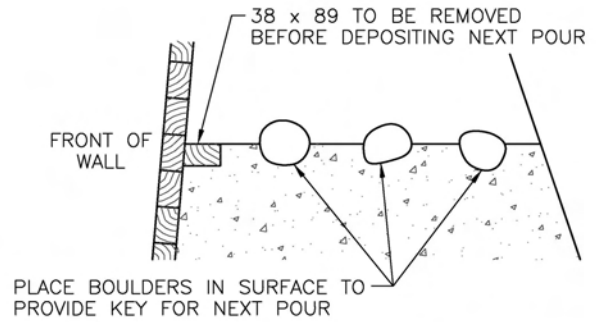

DETAIL OF HORIZONTAL CONSTRUCTION JOINT

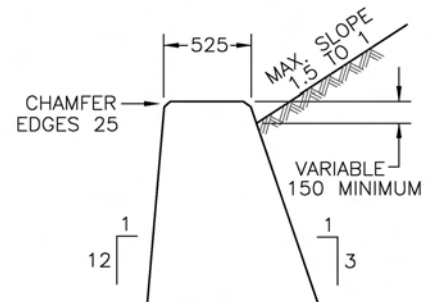

SECTION MODIFIED FOR TOE WALL

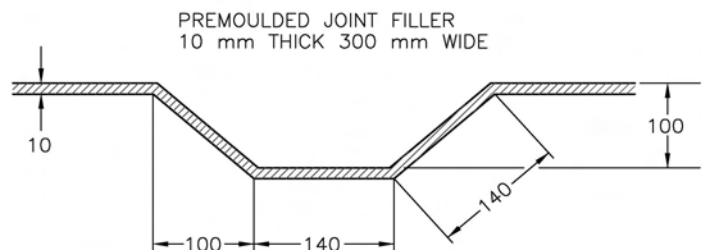
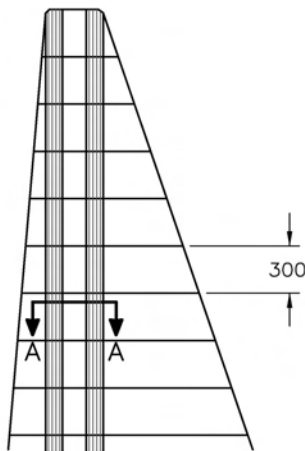

SECTION A-A EXPANSION JOINT

JOINTS TO BE APPROXIMATELY 9 m APART

NOT TO SCALE

ALL DIMENSIONS ARE IN MILLIMETRES UNLESS OTHERWISE NOTED

THIS PAGE IS LEFT INTENTIONALLY BLANK

SECTION 232

METAL BIN-WALL

232.01 Scope – This Section covers the construction of metal bin type retaining walls in accordance with the general layout and details indicated on Drawings 1-SP232 through 3-SP232.

232.02 Provision of Metal Bin-Wall – Bin-wall of the design (depth to height ratio) called for shall be constructed at the locations and as shown on the Drawings with the materials, accessories, and necessary ancillary work all in accordance with the details indicated on the Drawings, Specifications, Special Provisions, the standard Drawings or as directed by the Ministry Representative.

232.03 Materials – Bin-wall materials will be supplied by the Contractor in accordance with the Contract specifications.

Structure backfill shall be well-graded granular material with a maximum size of 75 mm and not more than 8% passing a 0.075 mm (#200) sieve.

232.04 Construction

232.04.01 Construction – Construction shall be carried out with all labour, tools, equipment and incidentals necessary to complete all bin-walling in accordance with good work practice.

232.04.02 Foundation – Foundation excavation shall be carried down to the depths shown on the drawings or to such greater depths as the Ministry Representative may direct. In the case where rock, hardpan or other unyielding material is encountered, it shall be removed to a depth 300 mm below the design grade and backfilled in accordance with SS 232.04.04.

232.04.03 Erection – The units shall be assembled as shown on the drawings. Components shall be handled

carefully and any which are damaged shall be removed and replaced with new components at the Contractor's expense.

Before the assembly bolts are tightened, columns shall be checked for line and batter or plumbness, where applicable.

232.04.04 Backfill – Structure backfill material shall be placed as wall foundation, backfill inside the bins, and for 0.6 m behind the wall. The material shall be spread in layers not exceeding 150 mm in thickness and shall be compacted to a minimum 95% of the laboratory density obtained by the current ASTM test method D 698.

Backfill inside each bin shall progress simultaneously but not in advance of that behind the wall.

Note: Bin wall may be backfilled as it is erected provided that the columns are held in correct position while the backfill is being placed.

232.05 Measurement and Payment – Metal bin-type retaining walls shall be paid for at the Unit Price bid per square metre of facial area of wall which shall be full compensation for supply, hauling to the site and erection.

Excavation for foundation shall be paid for at the rate bid for "Foundation Excavation" or "Roadway Drainage and Excavation", as specified in the Special Provisions or on Schedule 7.

Backfill in and around the bins shall be paid for at the rate bid for "Structure Backfill" which shall be full compensation for supplying, hauling to the site, placing and compaction.

THIS PAGE IS LEFT INTENTIONALLY BLANK

SECTION 303

CULVERTS

SCOPE

303.01. This section covers the construction of pipe culverts.

DEFINITIONS

Backfilling – means the operation of filling the embedment and backfill material.

Backfill Material means fill material used above the embedment material and below the lower of the subgrade or finished grade or the original ground.

Bedding Material means the material used to support the pipe culvert.

Embedment Material means material from the bottom of the bedding to the bottom of the backfill.

Subgrade means the grade upon which the first layer of select granular sub-base or base material is laid.

MATERIALS

303.02 The Contractor shall supply all material in accordance with SS 145.15 and as follows below.

303.02.01 Concrete Pipe (CP) - supplied in accordance with CSA A257

303.02.02 Corrugated Steel Pipe (CSP) - supplied in accordance with SS 320.

303.02.03 Structural Plate Corrugated Steel Pipe (SPCSP) - supplied in accordance with SS 320.

303.02.04 Polyethylene Pipe (PP) – supplied in accordance with SS 317.

303.02.05 PVC Pipe – supplied in accordance with SS 318.03

CONSTRUCTION

303.03. General

303.03.01 Backfill Material – construction shall conform to SS 201 Roadway and Drainage Excavation

303.03.02 Freezing Temperatures - When the air temperature is below 0°C, no backfilling is allowed unless otherwise accepted by the Ministry Representative. When

acceptance is granted, all backfill materials shall be in a thawed state when placed and compacted. Frozen granular backfill materials will not be permitted. No backfill material will be permitted to be placed directly on frozen substrate.

303.04 Concrete, Corrugated Steel, Polyethylene and PVC Pipes (this subsection does not cover SPCSP).

303.04.01 Layout – All culverts shall be laid out and constructed in general accordance with the lines, grades, and locations specified in the Drawings, or as directed by the Ministry Representative. Culverts are to be field fit by the Contractor, to reflect actual conditions encountered on-Site, and approved by the Ministry Representative prior to installation.

Such field fits will normally involve minor changes in location, elevation, grade, skew, depth and/or length resulting from actual local drainage course locations, post-stripping surface elevations, final ditch depths, and other factors.

Some culverts may be designed to control drainage, and are not to be field fit without the approval of the designer and Ministry Representative. Any such culverts will be identified in advance for the Contractor, through a note on the Drawings, in the Special Provisions, or by the Ministry Representative.

303.04.02 Flow Obstructions – Any obstacles to flow, such as filter cloth used for siltation control, shall not be placed directly on the end of any culvert. Where practicable, there shall be a minimum spacing of 1 m between the end of the culvert and any obstacles to flow.

Any obstructed culvert shall be cleaned out in accordance with SS 165.10.07.

303.04.03 Inlet and Outlet Ditches - Inlet and outlet ditches to culverts shall be constructed to the lines and grades as shown in the design.

303.04.04 Trenching - The trench and other preparatory work shall be approved by the Ministry Representative before actual placing starts.

A full trench condition shall be provided wherever possible; a minimum trench depth shall be 50% of the pipe

culvert diameter. If, in the opinion of the Ministry Representative, the material in the bottom of the excavation is of such a character as to cause unequal settlement along the length of the culvert, the trench shall be dug below the grade to such depth as ordered, backfilled with gravel or other suitable material, and compacted to ensure a firm and uniform foundation.

303.04.05 Placing - Concrete pipe culvert shall be laid beginning at the downstream end with the bell end pointing upstream. Pipe culvert with elliptical reinforcement shall be laid with the minor axis of the reinforcement as marked by the manufacturer in a vertical position.

When jointing concrete pipe culverts the trench shall be in a dry condition and the joints shall be cleaned and wetted before sealing with mortar. The mortar shall consist of one part Portland Cement to two parts fine sand, mixed to the proper consistency. Sealing shall be neatly and thoroughly done, and the interior of the pipe culvert cleaned of all surplus mortar. Joints shall be kept damp with burlap or earth for at least three days after sealing.

CSP shall be laid beginning at the downstream end. With riveted CSP, the outside laps shall point upstream and the longitudinal joint shall be on the side. There is no directional restriction with helical CSP.

303.04.06 Backfilling - Embedment Material shall consist of mineral aggregate and shall meet the gradation specified in Table 303-A.

Bedding material shall extend a minimum of 150 mm below the culvert invert. The top of the bedding, upon which the pipe culvert is to be laid, shall be shaped so that at least 25% of the circumference of the pipe culvert is in contact with the prepared bedding for the whole of its length.

Embedment material for embankment installation shall extend a minimum of two-thirds of the span or 0.9 m beyond the culvert span on each side, whichever is greater. Embedment material for trench installation shall extend a minimum of 0.3 m on either side.

Embedment material shall be placed in layers not exceeding 150 mm in depth when compacted. Embedment material shall be compacted to a minimum 95% (100% within 300 mm of subgrade elevation) of the laboratory density as determined in accordance with ASTM D 698. Backfilling shall be done symmetrically. The differential height of backfilling material on either side of the culvert shall not exceed 300 mm.

The material within 450 mm directly above the crown of the pipe culvert shall be laid and compacted as one lift. For

a culvert with crown within 300 mm of subgrade, installation methods shall be approved by the Ministry Representative.

TABLE 303-A: EMBEDMENT MATERIAL GRADATION REQUIREMENTS FOR CONCRETE, CORRUGATED STEEL, POLYETHYLENE AND PVC PIPE CULVERTS

SIEVE SIZE (mm)	PERCENTAGE PASSING
31.5	100
25	60-100
19	15-100
2.36	10-100
0.075	0-5

303.05 Structural Plate Corrugated Steel Pipe/Pipe-Arch Culverts (SPCSP)

303.05.01 Excavation – shall conform to SS 407 Foundation Excavation. If a coarse boulder material or solid rock is encountered when preparing the bed of the SPCSP, the material shall be excavated to a minimum depth of 300 mm below the SPCSP invert and backfilled with granular material having a maximum size of 75 mm.

303.05.02 Assembling - All bolted plates shall be in contact for the full width and length of the seam lap. The bolts in the valley of each longitudinal seam shall be nearer to the visible edge of the plate than the bolts in the crest. The torque on the bolts prior to backfilling shall be between 200 and 340 Nm, or as directed by Ministry Representative. A minimum of 5% randomly selected bolts shall be tested in each longitudinal and circumferential connection. The installation shall not be accepted if 10% or more of tested bolts do not meet the specified torque requirements.

Rotation of the pipe culvert and/or spiralling of the longitudinal seams shall not be permitted. The upward or downward crown deflection shall not exceed 2% of the rise.

303.05.03 Backfilling –Backfilling shall extend to the limits as noted on the drawings. For multiple SPCSP structures, structural backfill shall be provided between

SECTION 303

CULVERTS

adjacent SPCSP structures.

The diameter or the span and rise of SPCSP shall not vary from the manufactured dimensions by more than 5% during backfilling operations.

The embedment material shall be free draining, well graded, granular material approved by the Ministry Representative.

The top surface of the bedding upon which the pipe culvert is to be laid shall be constructed to the true grade and alignment as shown in the drawings.

The embedment material shall be placed and compacted in lifts not exceeding 200 mm compacted thickness, with each lift to a minimum of 95% of Standard Proctor Density prior to addition of the next lift. The bedding layer of a 200 mm thickness in direct contact with the invert shall be shaped to the pipe culvert curved invert and shall be left uncompacted.

Backfilling shall be done symmetrically. The differential height of backfilling material on either side of the SPCSP at any transverse section shall not exceed 400 mm.

The embedment material within 300 mm of the pipe culvert walls shall be free of stones exceeding 75 mm size. Heavy equipment shall not be allowed within 1 m of the pipe culvert walls.

End dumped or loose pushed material shall not be piled closer than 3 m from the pipe culvert. Hauling equipment shall not be operated over the pipe culvert until backfilling operations have completed a suitable cover approved by the Ministry Representative.

303.06 Culvert Endwalls – shall be constructed in accordance with the details shown on the Drawings. For concrete endwalls, construction and materials for concrete and reinforcement shall conform to SS 211 and SS 412 and excavation shall conform to the requirements of SS 407.

If specified on the Drawings, the Contractor may provide an alternative endwall product from the Ministry's Recognized Products List.

303.07 MEASUREMENT

303.07.01 Pipe Culverts - Pipe culverts will be measured by the METRE along its invert length as installed.

303.07.02 Concrete Endwalls - Concrete end walls will be measured by the CUBIC METRE.

303.08 PAYMENT

303.08.01 Pipe Culverts - Payment for excavation, pipe culvert assembling, placing, and backfilling shall be at the Contract Unit or Lump Sum Price bid for each of these items of work, or at the Contract Unit Price bid per metre of pipe culvert.

303.08.02 Concrete Endwalls - Payment for CONCRETE END WALLS will be at the Contract Unit or Lump Sum Price bid per size of endwall required. The Contract Unit Price shall include provision of everything necessary; precast or cast-in-place endwall, formwork, reinforcement, air entrained concrete, placing and tamping, stripping and cleaning, curing and any other work necessary in connection therewith, including excavation and backfilling, but excluding riprap.

303.08.03 Full Compensation - The price(s) bid shall be full compensation for the cost of furnishing all labour, materials, equipment, tools and incidentals necessary to complete the work as specified in the contract.

303.08.04 Type A Excavation - Excavation of Type A material encountered in the trench or endwall excavation will be paid at the Contract Unit Price for Type A, or where such an Item is not included in the Contract, at a negotiated price or on a Force Account Basis.

THIS PAGE IS LEFT INTENTIONALLY BLANK

SECTION 308

COATING SYSTEMS

308.01 Scope - This Section defines the coating systems required for shop and field coating of structural steel or wood/concrete surfaces which may be exposed to exterior corrosive conditions.

308.03 Standards and Specifications

a) Specifying Bodies:

- **SSPC**, The Society for Protective Coatings, has a large number of coating and cleaning specifications.
- **ASTM**, The American Society for Testing and Materials, produced test procedures for a wide range of products and processes.
- **NACE**, The National Association of Corrosion Engineers, also produces specifications and test procedures for coatings and corrosion engineering. All have a web presence available by searching the name above.

b) Colour Specifications using a five digit number refer to the US Federal Specification 595b colour numbers.

c) Measuring Units

The metric unit (μm) or imperial unit (mil) can be used interchangeably, at the conversion factor of:

1 mil = 25 μm (1 mil = 1 thousandth of an inch)

308.04 System Selection Table – The System Selection Table contained in the Coating Systems section of the Ministry Recognized Products List (RPL) summarizes the coating systems currently in use. The table lists application areas where specified coating systems may be used. It is intended to assist in the choice of a coating system for specific applications. Some systems may find use in more than one specific application or in applications not mentioned.

Where a system is specified in a contract, only those coating products listed for that coating system may be

used, unless a coating product listed as “tentative” is excluded for a specific application.

308.05 System Selection Criteria - The selection of a coating system is dictated by the location and environment of the structure to be coated. The coating system may be applied in a shop or in the field. The field location may necessitate a specific maintenance regimen, for example, a complete recoat or a single overcoat. The environment may be moderately or severely corrosive. In addition, there may be concerns with limiting overspray.

The following general comments apply to all coatings.

- Coatings shall not be mixed and matched between suppliers, or within a supplier's product line.
- All coatings shall bear the manufacturer's name and address, batch number, paint type, date of manufacture, DOH or US Federal Specification 595b color code, and mixing and application instructions. All labels shall contain the requisite WHMIS label information and be accompanied by a valid MSDS. All coatings are subject to inspection and testing before acceptance or at the time of application.

308.06 Coating Products - The Ministry Recognized Products List (RPL) lists coating products that have been reviewed and accepted for use on Ministry projects. The RPL can be reviewed at the following Ministry web site:

http://www.th.gov.bc.ca/publications/eng_publications/geo_tech/Recognized_Products_Book.pdf

Products not listed on the Ministry Recognized Products List shall not be used.

Products on the RPL shall be used in accordance with the introduction/definitions, descriptions, notes qualifiers and all other information given in the RPL. The use of any product from the RPL by the Contractor shall in no way relieve the Contractor from its contractual obligations.

THIS PAGE IS LEFT INTENTIONALLY BLANK

REVISED SECTION

SECTION 312

STEEL TRAFFIC BARRIERS AND WOOD POSTS

312.01 Scope - This Section covers the quality and manufacture of steel beam guardrails, wood posts and accessory material for use as traffic barriers.

The layout and installation of materials specified in this Section are generally indicated on the Drawings of the SP312 series.

SS 604 covers the installation of the material of this Section together with the construction of ancillary work

312.02 Standards of Reference - Standards of various authorities are referred to herein generally in sufficient detail for the purpose of this Section. For detailed testing and other requirements reference to the Standards may be necessary from actual copies obtainable as follows:

CSA Canadian Standards Association: Standards Sales
13799 Commerce Parkway

Richmond, BC, V6V 2N9

ASTM: American Society for Testing and Materials,
1916 Race Street, Philadelphia,
Pennsylvania 19103

ARTBA: American Road and Transportation Builders Association
1219 28th Street, N.W.
Washington, DC 20007

AASHTO: American Association of State Highway and Transportation Officials
444 North Capitol Street N.W., Suite 225
Washington, DC 20001

312.03 General - Steel traffic barriers shall consist of rail sections fabricated for installation to develop a continuous beam strength with the necessary safety end feature components.

All rail sections and other components shall match the design profiles and dimensions of the AASHTO/ARTBA requirements cited below for full interchangeability of similar components regardless of the source of manufacture.

The name and/or trademark of the manufacturer and the metal thickness shall be clearly and permanently marked on each component clear of the splicing overlap and on the opposite face to the traffic side.

312.04 Steel Beam Guardrail - Guardrail shall be manufactured from open hearth, electrical furnace or basic oxygen semi-spring steel sheet galvanized before forming (or afterwards as may be specified or ordered for authorized special installations) all in general accordance with the AASHTO Standard Designation M-180 "Corrugated Sheet Steel Beams for Highway Guardrail" and shall conform to the following detail requirements.

Note: Design and part numbers are taken from the ARTBA Technical Bulletin #268-B, current edition (unless stated to be BCH Part numbers) and are reproduced on Drawings 6-SP312 through 10-SP312.

312.04.01 Beam Classification (According to the AASHTO Standard) - The shape, class and type together with the ARTBA design and part numbers shall be as specified on the Purchase Order, Work Order or Special Provisions in accordance with any applicable Contract Drawings and/or Drawings of the SP312 series, as selected from the following, the standard Drawings or as may be otherwise required or approved.

i) Shape - W-Beam are for ARTBA Design G4 and MB4 installations and Thrie-Beam for Design G9 and MB9 installation and both shall be accurately formed to profile, dimensions and tolerances of the AASHTO Standard with overall cross sections of 311 mm x 85 mm and 508 mm x 85 mm respectively (ARTA Designation RE-3 and RE-63).

ii) Class and Type - Unless otherwise specified or ordered, beams shall be Class A, Type 1. Authorized special installations for corrosive conditions and environment of industrial and marine areas may necessitate a Class A, Type 2 requirement.

Note: Type 4 shop primed beams will not normally be specified.

iii) Length - Normally 3.81 m (12' 6") nominal length beams (4.19 m, +0, -75 mm overall) will be required.

Note: 1.9 m (6' 3") and other lengths if specified or ordered may be considered a special order.

iv) Punchings - In addition to joining bolt holes, punchings may be designed as 7.82 m, 3.81 m or 1.9 m (25' 0", 12' 6", 6' 3" respectively), see Drawings, 1-SP312 and 2-SP312 for requirements.

Note: Punchings at 0.95 m, 1.27 m (3' 1 1/2" and 4' 2") and other centres if specified or ordered may be considered a special order.

v) Curved Rails - For curved rail data see Drawing SP312-11.

312.04.02 Metal

i) Properties - Properties of the base metal for beams and any transition section shall conform to the following requirements:

- Yield point minimum: 345 MPa
- Tensile strength minimum: 483 MPa
- Elongation minimum in 50 mm: 12%

SECTION 312

Note: End and buffer sections shall have minimum yield point of 227 MPa and minimum tensile strength of 310 MPa.

ii) Sheet Thickness - Class A base metal thickness shall be 2.8 mm nominal (2.67 mm minimum) and for special authorized installations Class B 3.5 mm nominal (3.43 mm minimum).

iii) Sheet Widths - Sheet Widths shall be minimum 483 mm for W-Beams and 749 mm for Thrie-Beams both with a permissible tolerance of minus 3.2 mm.

312.04.03 Zinc Coating - Zinc for coating beams and ancillary sections shall be at least equal to “Prime Western” conforming to CSA Standard HZ2 or AASHTO Standard M120 (ASTM B 6) “Slab Zinc”.

The coating shall be firmly bonded to the base metal whether fabrication is from galvanized sheet or galvanizing is specified after fabrication.

The average mass of zinc coating Type 1 (AASHTO M180) shall be 610 g/m² for three specimens but minimum 550 g/m² for any individual specimen being the total amount on both sides of the sheet or beam. When Type 2 is specified or ordered (see Subsection 312.04.01 (ii)) the coating shall have average 1220 g/m² and 1100 g/m² individual minimums.

312.04.04 Quality of Work - Beams shall be punched for splice and post bolts in strict conformity with the AASHTO Standard to the designated number of and centre to centre spacing of posts.

Upon delivery the beams shall be ready for assembly and installation.

Note: No punching, cutting or welding will be permitted on site except for special details in unforeseen and exceptional cases and to the prior approval of the Ministry Representative.

Warped or otherwise deformed beams will be rejected as will those with injurious defects or excessive roughness of the zinc coating.

Beams for concave and/or convex curved installations with a radius of 45 m or less shall be accurately and smoothly bent in the shop with minimum deformity. The radius of curvature shall be clearly stencilled on the back of each curved rail section.

312.04.05 Inspection - No material shall be shipped prior to inspection or until a release for shipment has been issued by the Ministry Representative.

All materials may be inspected before shipment to the construction site, or at the construction site, or both. The supplier or manufacturer shall provide the necessary facilities to enable the Ministry Representative to expeditiously examine selected pieces or take specimen samples for testing from the material lot(s) clearly identified for intended supply to the Ministry.

STEEL TRAFFIC BARRIERS AND WOOD POSTS

Identification shall be such that after inspection and testing the lot may be subsequently identified for acceptance or rejection.

Inspection of material before shipment shall not exclude its subsequent rejection at the construction site if found to fail any requirements of this specification.

312.04.06 Examination - Examination may include the following:

i) Dimension measurements for size and thickness all of which shall be within the tolerance measurements specified by SS 312.04.01 (i) and Table 312-A.

ii) Coating generally shall be smooth, free of beading or sharp projections at edges. Coating adherence shall prevent the peeling of any portion of the zinc coating so as to expose the base metal by cutting or prying with a stout knife under considerable pressure.

TABLE 312-A

GALVANIZED BEAM THICKNESS			
FINISH			
Base Metal	Type 1	Type 2	Tolerance
Class A (2.8 mm nominal)	2.74 mm	2.82 mm	minus 0.23 mm
Class B (3.5 mm nominal)	3.51 mm	3.58 mm	minus 0.25 mm
Note: Tolerance given is for under specified thickness; there is no limit for over thickness.			

312.04.07 Testing - When required by the Ministry Representative, testing shall be carried out according to ASTM A 90 - “Weight of Coating in Zinc Coated Articles” (also AASHTO T65) to determine the mass of galvanizing in conformity with the requirements of SS 312.04.03. Alternatively magnetic gauge determination in accordance with ASTM E 376 may be permitted.

The testing of the mechanical properties of the base metal may be carried out by the Ministry Representative for compliance with the requirements of SS 312.04.02.

312.04.08 Rejection and Retests - Should the beam tested fail to meet the testing requirements specified above, two additional beams as selected by the Ministry Representative shall both meet the test requirements in every respect, otherwise the complete lot represented by the samples will be subject to rejection.

In the event of complete lot rejection and prior to any further testing by the Ministry, the intended replacement lot shall be satisfactorily tested by a mutually acceptable

SECTION 312

independent testing agency at no expense to the Ministry. When the time delay for retesting is unacceptable to the Ministry the order or part thereof will be subject to cancellation.

Rejected material shall be replaced at the Supplier's or Contractor's expense, including shipping charges and removal of rejected material at the construction site, if applicable.

312.05 Guardrail Accessories

312.05.01 Transition Section - Transition section for W-Beam to Thrie-Beam shall be of matching metal thickness and finish and fabricated to the ARTBA design profile (RE-69) to provide a smooth and uniform transition of beam widths and corrugations.

312.05.02 End Sections - End sections shall be of the type specified or ordered as indicated on standard Drawing 2-SP312. Double face buffer (ARTBA Designation RE-7) sections for breakaway cable terminal (BCT) assemblies shall be of the stipulated radius and the metal thickness and finish to match the beams. Terminal connectors (RE-8), as return sections of the BCT buffer ends and as normal beam connections (RE-8 or RE-67) to bridge parapets, abutments and the like, the metal thickness shall be Class B with matching finish.

312.05.03 Back-up Plates - Back-up Plates required where steel beams between splices are to be installed to any square or channel section steel posts (standard 305 mm lengths) shall be fabricated of the stipulated lengths from the standard beam section (as or similar to RE-4 or RE-64 ARTBA Designation).

312.05.04 Bolts, Nuts and Washers - Button-head bolts for joining beam sections in the length or to end sections and for fixing beams to posts (ARTBA Designation F-3) and hexagonal-head bolts elsewhere shall be of the stipulated diameter, thread length and/or bolt length.

Bolts generally shall conform to the requirements of ASTM A 307, nuts to ASTM A 563 Grade A and plain washers to ANSI B27.2 Type A requirements, and unless otherwise specified, all galvanized according to ASTM A 153.

Plate washers where required (as ARTBA Designations F-12, F-36 and F-38) shall be of the size and thickness stipulated to ASTM A 36 and galvanized to ASTM A 153 requirements.

312.05.05 Post Sleeve - Post Sleeve for BCT breakaway cable fixing through the wood post shall be a 150 mm length of 60 mm outside diameter galvanized pipe conforming to ASTM A 120 for "standard weight" pipe (ARTBA F-34).

312.05.06 Cable Assembly - Cable Assembly for BCT installation shall consist of a swaged fitting, 25 mm diameter threaded stud, locking pin, nut and washer at each end of a cable of 19 mm nominal diameter, 6 x 19

STEEL TRAFFIC BARRIERS AND WOOD POSTS

wire strand core independent wire rope core, galvanized, right regular lay wire rope with a minimum breaking strength of 200 000 N (45,000 lb) and conforming to AASHTO M-30 with the overall assembly length of 1980 mm developing a similar breaking strength (ARTBA F-37, F-35 and complete with plate washers, F-36 one end and F-38 the other).

312.05.07 Anchor Plate - Anchor Plate for the breakaway cable attachment to the steel beam for BCT assemblies shall be fabricated to the ARTBA design profile (RE-71) from steel plate conforming to ASTM A 36 and galvanized according to ASTM A 123 after forming and drilling for and including eight 16 mm diameter hexagonal-head bolts 38 mm long each with nut and 3.5 mm thick plain washer 44 mm outside diameter (ARTBA F-8 and F-13) complying with SS 312.05.04.

312.05.08 Anchor Inserts - Anchor Inserts for fixing terminal connector end sections to existing concrete shall be heavy duty hexagonal bolt type expansion anchor "Hilti" size HSL M16/25, or other pre-approved alternative with hardened plain washer minimum 4 mm thick and 57 mm outside diameter with all metal surfaces galvanized.

Anchors of alternative manufacture may be approved by the Ministry Representative provided equivalence of design and effect can be demonstrated.

312.05.09 Steel posts - Where required for installation on concrete, steel posts shall be fabricated from standard structural steel H-beam or bent steel plate to channel or "C" shape and with similar section short length offset "blocks" and heavy base plates and all shall conform to CSA Standard G40.21M type 300 W or ASTM A 570, Grade 45 and/or ASTM A 36.

All welding shall conform to the requirements of the American Welding Society Code AWS D1.1. All welding shall be carried out by qualified operators of a contractor approved by the Canadian Welding Bureau or the American Welding Society to the requirements of CSA Standard W47.1 Division 3 or the AWS Code.

Galvanizing, according to CSA Standard G164 or ASTM A 123, shall be carried out after all punching, drilling, cutting and welding.

Post type, size and length similar to ARTBA Designation P-42 or P-53, complete with connecting bolts (F-8), expansion anchors similar to SS 312.05.08 or through bolts and backing plates or other fixing devices shall be as stipulated and/or detailed.

Alternative shape, type and size of post members and fixing devices to those detailed or ordered may be permitted by the Ministry Representative provided equivalence of design and effect can be demonstrated.

312.06 Wood Posts

SECTION 312

312.06.01 Square Posts - Square posts and offset blocks shall be Douglas Fir/Hemlock “No. 1, Structural Posts and Timber”, graded in conformity with the requirements of NGLA “Standard Grading Rules for Canadian Lumber”.

Wanes on any face shall not exceed the following width:

- Above grade (including blocks): 25 mm
- Below grade: 60 mm

being the minimum permissible post width less the portion entirely free of wane.

Posts and blocks shall be supplied in the exact lengths ordered or specified and unless otherwise required on the Purchase Order, Work Order, drawing or specification the scantling shall be nominal 200 mm x 200 mm, and pair of 200 mm x 150 mm for each BCT installation, with dressed on four sides minimum dimension of 189 mm x 189 mm and 189 mm x 138 mm respectively and a tolerance of plus 3 mm.

312.06.02 Preservation Treatment - All posts and blocks shall be pressure treated in accordance with CSA Standard 080-M “Wood Preservation”.

Unless otherwise specified or stipulated on the Purchase Order, Work Order, specifications, or drawings, the preservatives and retention of preservatives shall conform to the recommendation of CSA Standard 080.14-M Table I “Minimum Retention of Preservatives in Pressure Treated Wood for Highway Construction” under the heading of “Posts-Guardrail...” for square posts and blocks.

Prior to treatment all material shall be air seasoned in accordance with AWP Standard M1 Paragraph 1.31 to a moisture content of 15% to 22% before pressure treatment.

STEEL TRAFFIC BARRIERS AND WOOD POSTS

In exceptional circumstances the Ministry Representative may permit conditioning by steaming for a total of not more than 6 hours at a temperature not in excess of 115°C.

312.06.03 Inspection - All processing of the material shall be open for inspection by the Ministry Representative with free entry to the treating plant while the work is being performed.

No material shall be shipped prior to inspection or the written release for shipment by the Ministry Representative.

Material inspected before shipment shall not bar its subsequent rejection after delivery if found to fail any requirements of this specification. Rejected material shall be replaced at the Supplier’s expense including shipping charges and removal of rejected materials if applicable.

Note: Inspection of material already in bundles ready for shipment shall be considered as “incomplete”, and the material will be subject to final inspection by the Contractor only when the bundles are opened immediately prior to use.

The Supplier shall advise the Ministry Representative at least two full working days before the material is ready for inspection prior to shipment. A Supplier in a distant location or outside B.C. shall advise the Ministry Representative at least one full week before the material is ready for inspection prior to shipment. After inspection the Ministry reserves the right to conduct whatever tests are deemed necessary to confirm that the material complies with the requirements of this specification before a release for shipment is issued.

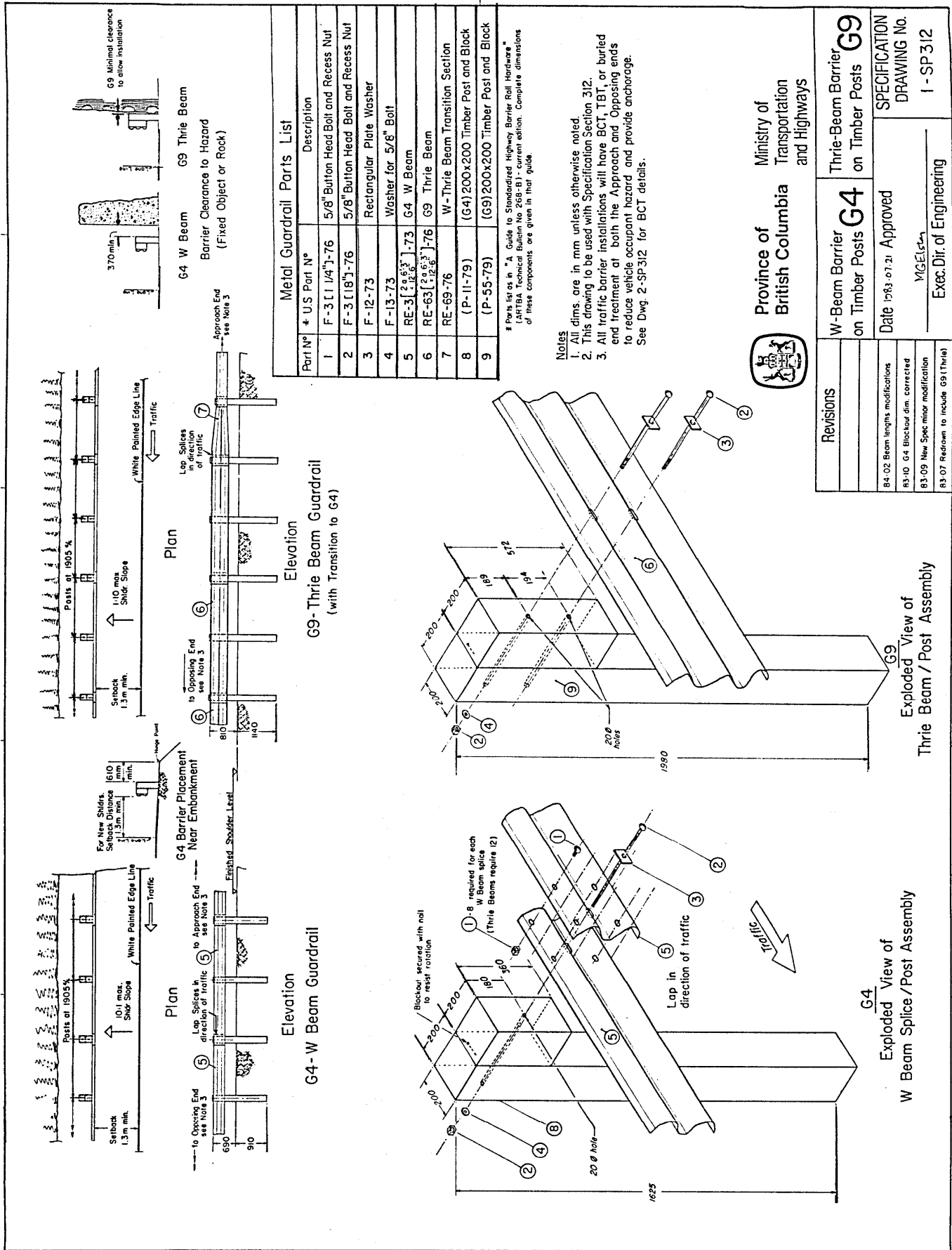

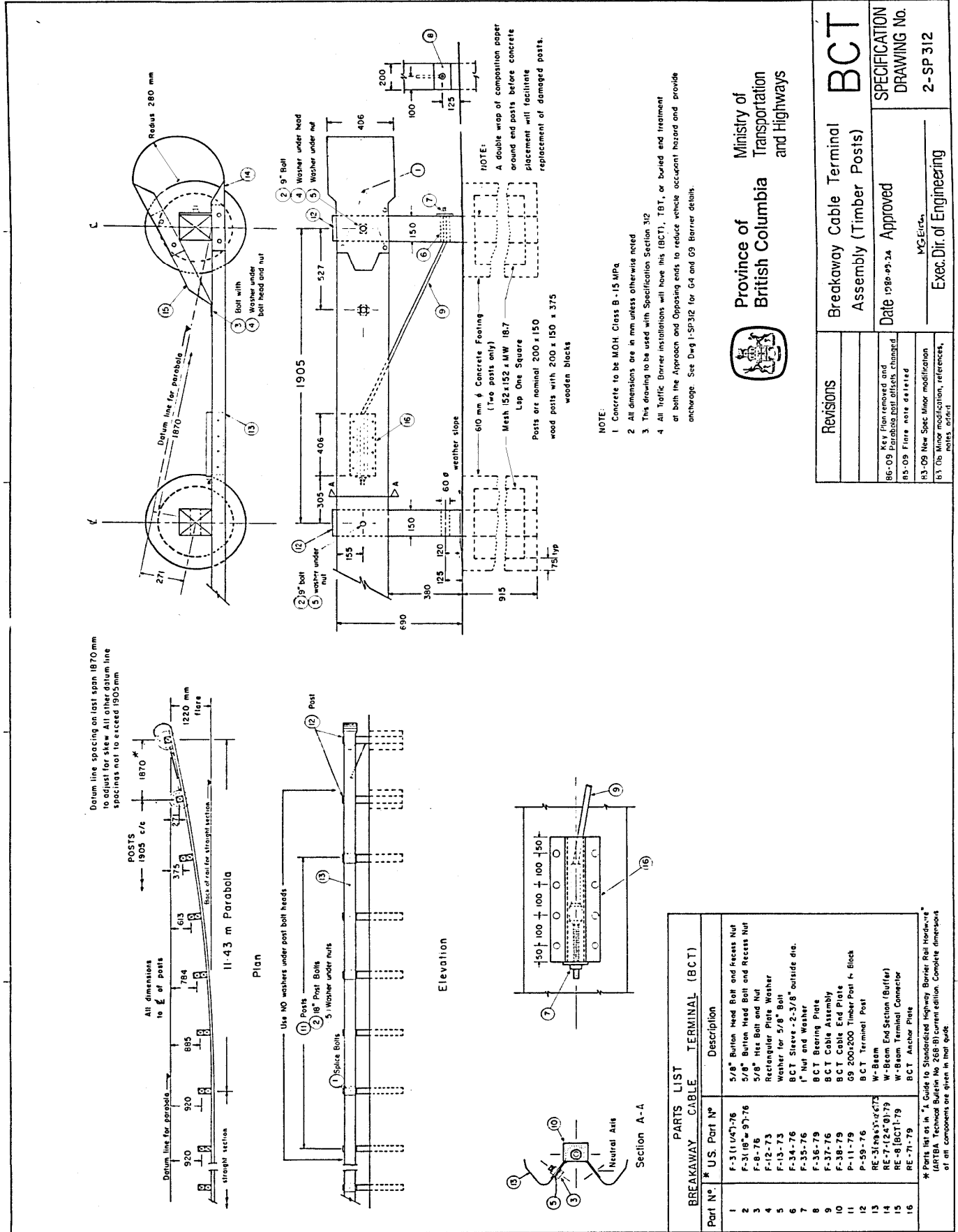

Revisions		Breakaway Cable Terminal Assembly (Timber Posts)	BCT
Key Item removed and Parabolic Post Details Deleted			
86-09		Date 12/80-03/24	Approved
85-09		MG/ECL	
83-09		Exec. Dir. of Engineering	
81		Minor modification, references, notes, correct	

NOTE:
 1. Concrete to be M.O.H. Class B -15 MPa
 2. All dimensions are in mm unless otherwise noted
 3. This drawing to be used with Specification Section 312
 4. All Traffic Barrier installations will have this (BCT), TBT, or buried and treatment of both the Approach and Opposing ends to reduce vehicle occupant hazard and provide anchorage. See Draw 1-SP312 for G4 and G9 Barrier details.

Part No.	US Part No.	Description
1	F-3 (1/4")-76	5/8" Bolt Head Bolt and Recess Nut
2	F-31 (1/2")-97-76	5/8" Bolt Head Bolt and Recess Nut
3	F-8-76	5/8" Hex Bolt and Nut
4	F-12-73	Rectangular Plate Washer
5	F-13-73	Washer for 5/8" Bolt
6	F-34-76	BCT Sleeve - 2-3/8" outside dia.
7	F-35-76	1" Nut and Washer
8	F-36-79	BCT Bearing Plate
9	F-37-76	BCT Cable Assembly
10	F-38-79	BCT Cable End Plate
11	P-11-79	G9 2001-200 Timber Post h. Block
12	P-59-76	BCT Terminal Post
13	RE-31 (9x5 1/2 x 6 1/2)	W-Beam
14	RE-7 (12 1/2 x 8) 79	W-Beam End Section (Buffer)
15	RE-8 (BCT) 79	W-Beam Terminal Connector
16	RE-71-79	BCT Anchor Plate

* Part 151 is in "1 Guide to Standardized Highway Barrier Bolt Heads" (ARBA Technical Bulletin No. 268-B) current edition. Complete dimensions of all components are given in that guide.

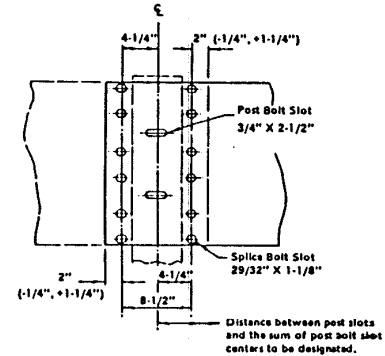
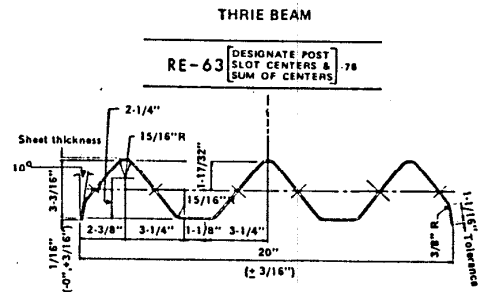
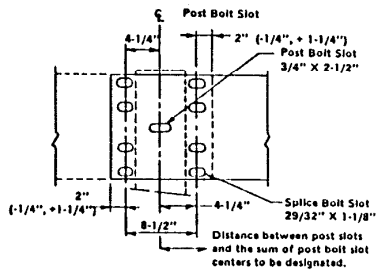
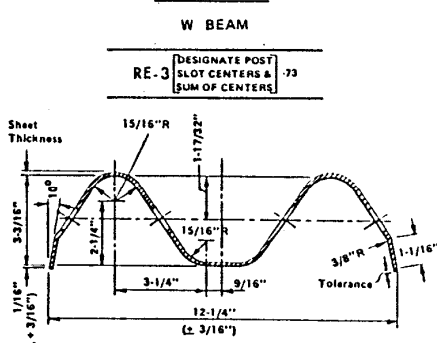

5/8" BUTTON HEAD BOLT AND RECESS NUT

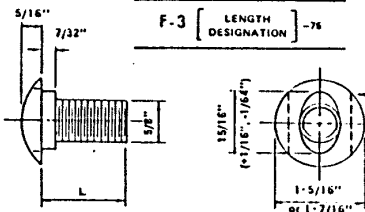

NOTE: Optional 1 1/4" long splice bolt heads with flat sides are available to facilitate easier removal for maintenance purposes (AWI part No. G58 114).

L	Thread Length
1-1/4"	Full length thread
2"	1-1/2" min. thread length
3-1/2"	1-3/4" min. thread length
18"	2-1/2" min. thread length
25"	2" min. thread length

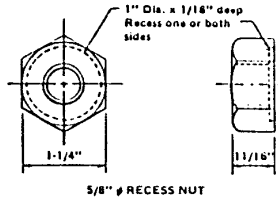

RECTANGULAR PLATE WASHER

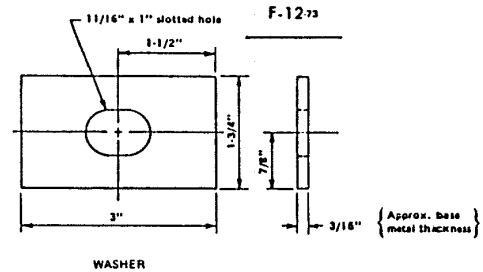

WASHER FOR 5/8" BOLT

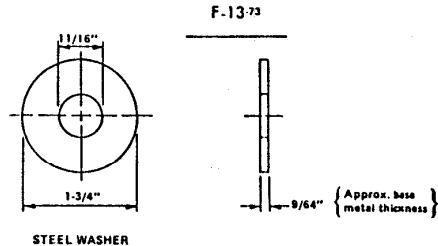

W - THRIE BEAM TRANSITION SECTION

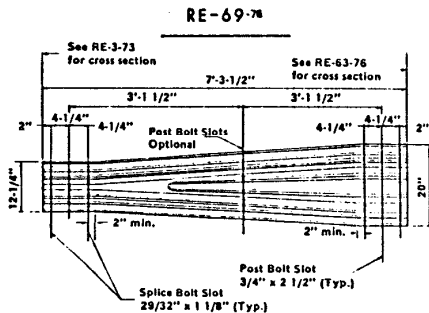

Province of British Columbia Ministry of Transportation and Highways

Revisions	STEEL GUARDRAIL BEAM PARTS (ARTBA DESIGNATIONS)	
	Date 1984-09-24 Approved	SPECIFICATION DRAWING No.
	MGEI/str	6-SP 312
	Exec. Dir. of Engineering	

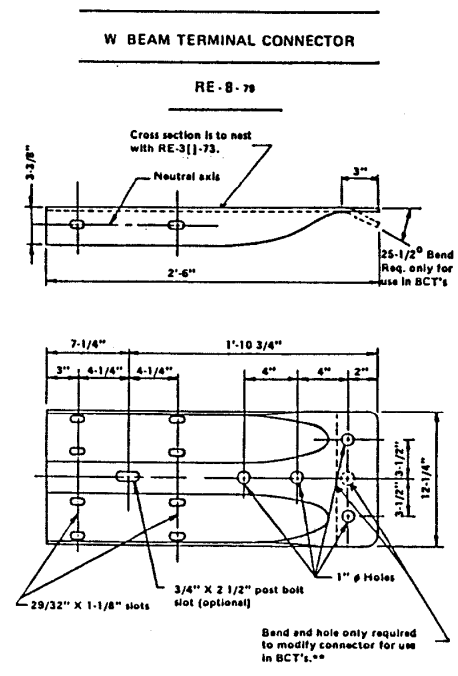
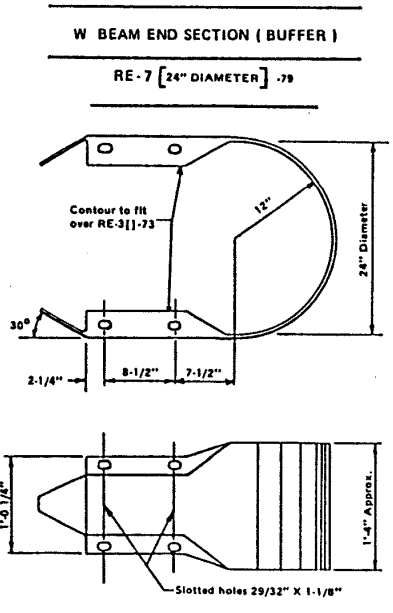

**To obtain BCT details show part number as RE-8(BCT) - 78.

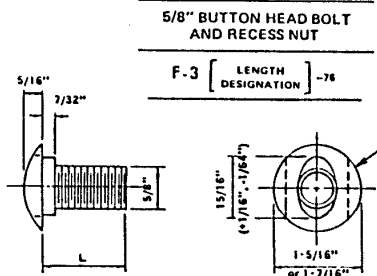

5/8" # BUTTON HEAD BOLT

L	Thread Length
1-1/4"	Full length thread
2"	1-1/2" min. thread length
3-1/2"	1-3/4" min. thread length
18"	2-1/2" min. thread length
25"	2" min. thread length

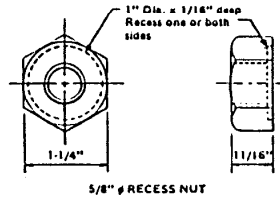

RECTANGULAR PLATE WASHER

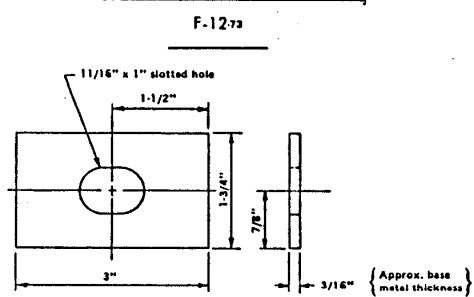

WASHER FOR 5/8" BOLT

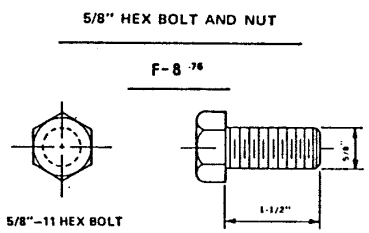
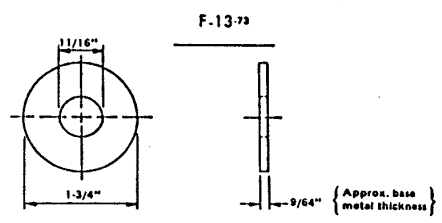

5/8"-11 HEX BOLT

5/8"-11 HEX NUT



Province of British Columbia

Ministry of Transportation and Highways

Revisions	STEEL GUARDRAIL B.C.T. END ASSEMBLY PARTS (TO ARTBA DESIGNATIONS)	
	Date 1984-04-24 Approved	SPECIFICATION DRAWING No. 7-SP 312
	MGE/ctm Exec. Dir. of Engineering	

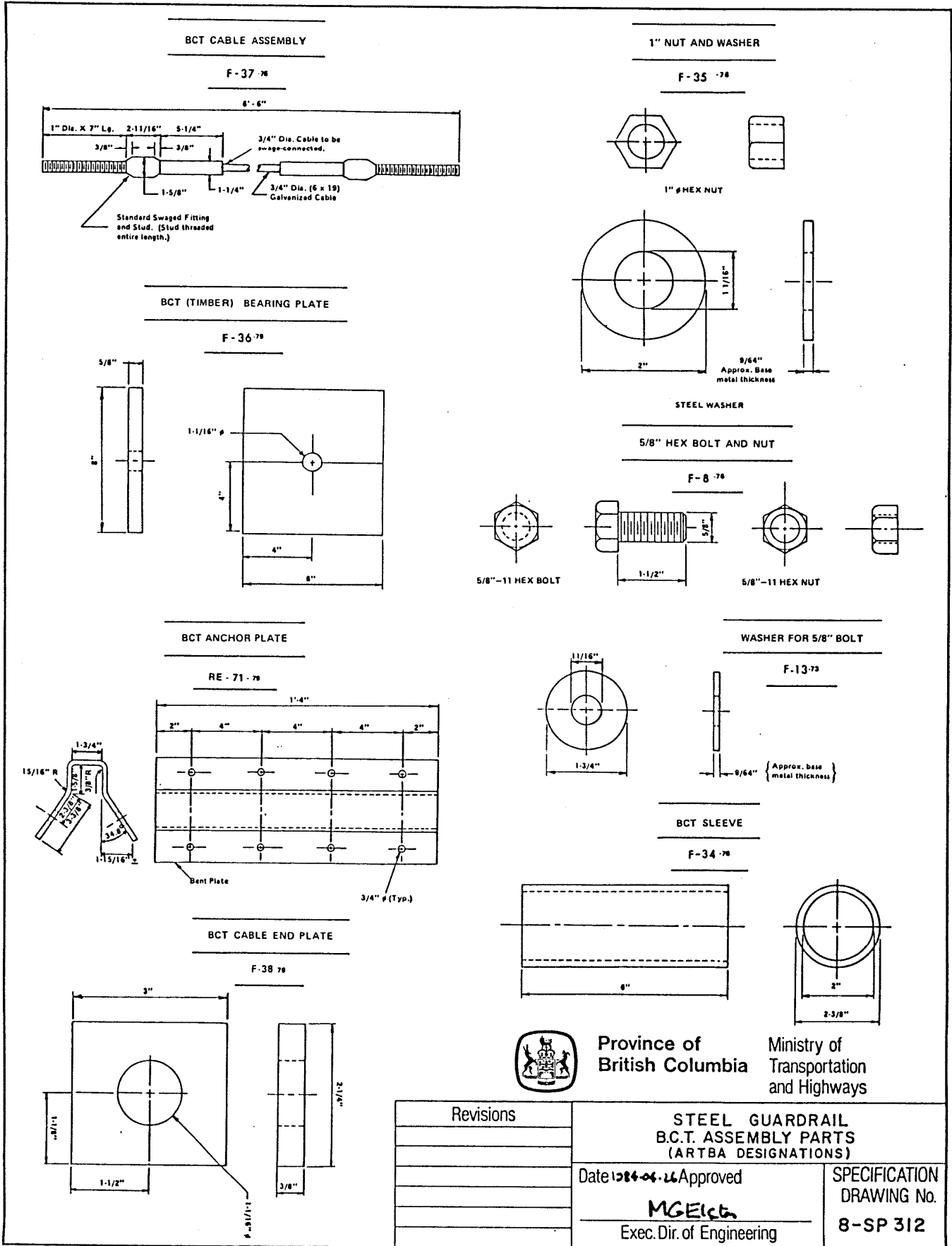

Province of British Columbia

Ministry of Transportation and Highways

Revisions	STEEL GUARDRAIL B.C.T. ASSEMBLY PARTS (ARTBA DESIGNATIONS)	
	Date: 2004-06-26 Approved	SPECIFICATION DRAWING No.
	MGE/ctb Exec. Dir. of Engineering	8-SP 312

W BEAM BACK-UP PLATE

RE-4-76

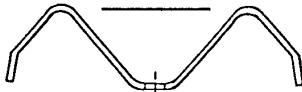

Dimensions same as RE-373

Slot 3/4" X 2-1/2"

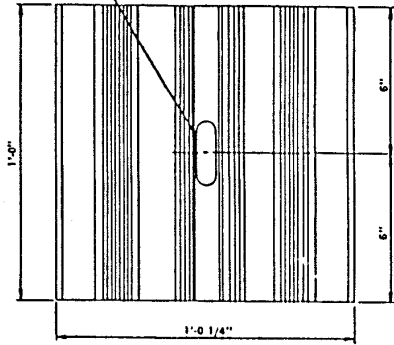

W BEAM BACK-UP PLATE

RE-4-[6"]-76



DIMENSIONS SAME AS RE-373

SLOT 3/4" X 2-1/2"

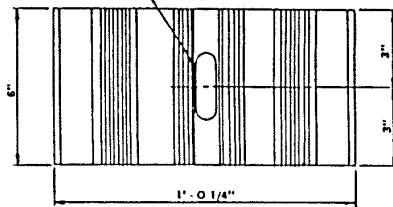

5/8" BUTTON HEAD BOLT AND RECESS NUT

F-3 [LENGTH DESIGNATION]-76

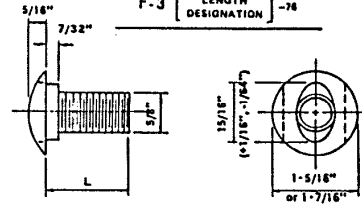

NOTE: Optional 1 1/4" long splice bolt heads with flat sides are available to facilitate easier removal for maintenance purposes (AWI part No. G58 114).

L	Thread Length
1-1/4"	Full length thread
2"	1-1/2" min. thread length
3-1/2"	1-3/4" min. thread length
18"	2-1/2" min. thread length
25"	2" min. thread length

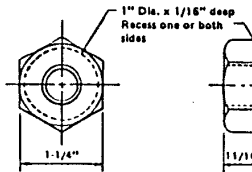

WASHER FOR 5/8" BOLT

F-13-73

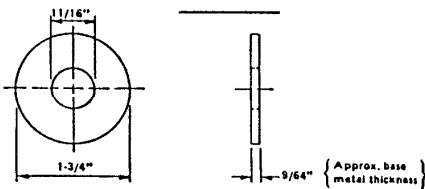

W BEAM TERMINAL CONNECTOR

RE-8-76

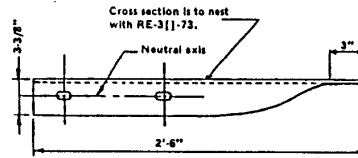

CONCRETE INSERT ANCHOR ASSEMBLY

F-33-73

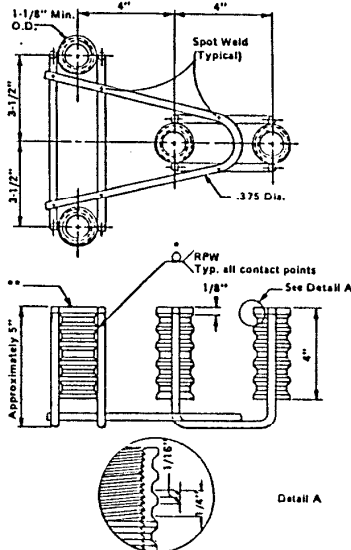

NOTE: F-33-73 includes 7/8" x 2-1/2" galvanized High Strength Hex Bolts and a 15/16" I.D., 2-1/4" O.D., 5/32" Thk., Type A Plain Washer.

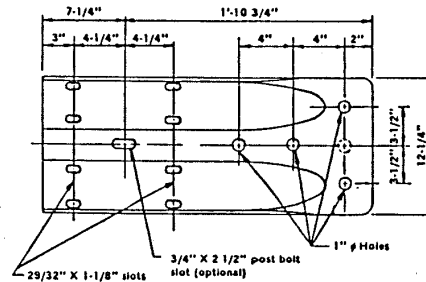

Province of British Columbia

Ministry of Transportation and Highways

Revisions

STEEL GUARDRAIL T.B.T. ASSEMBLY PARTS (ARTBA DESIGNATIONS)

Date 1984-04-26 Approved

MGEI
Exec. Dir. of Engineering

SPECIFICATION DRAWING No. 9-SP 312

STRUCTURAL SHAPE POST AND BLOCK

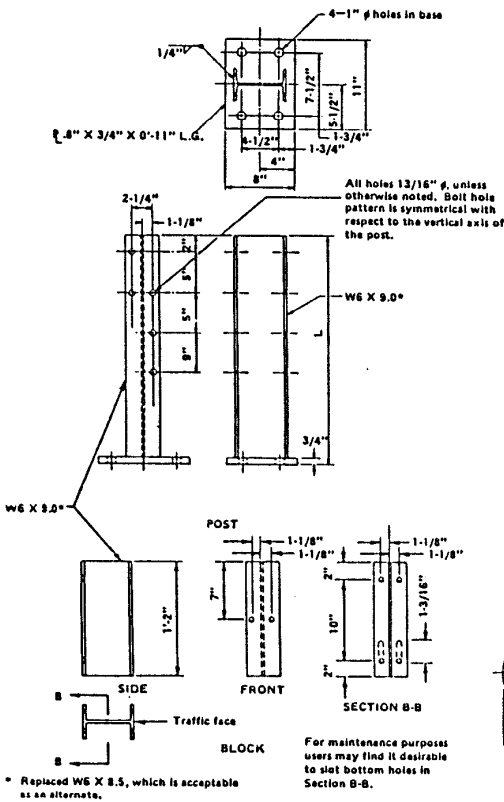

BENT PLATE POST AND BLOCK (STEEL)

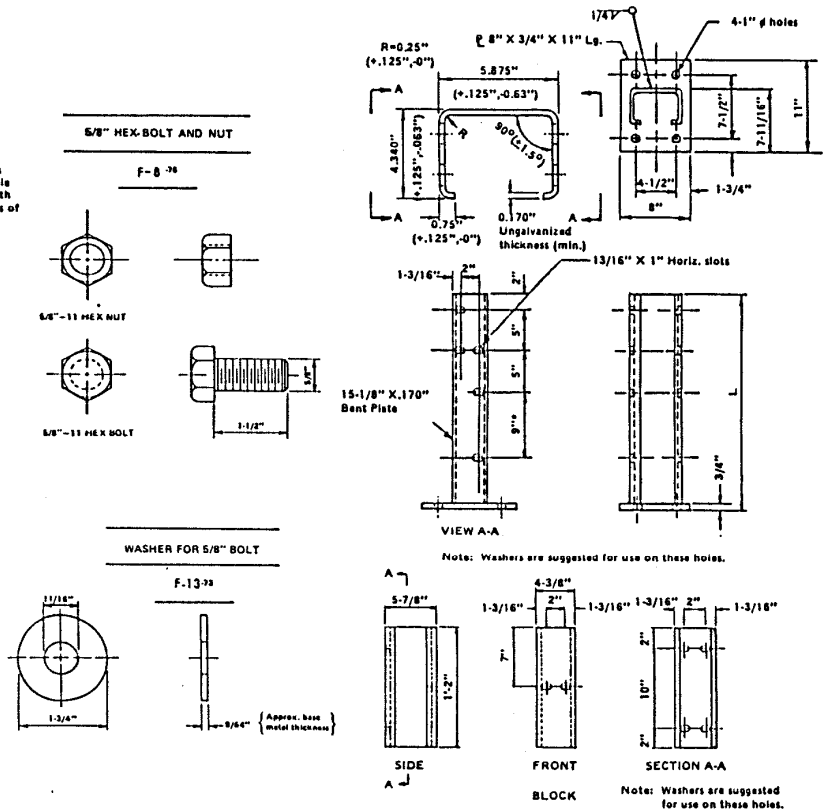

TYPICAL TOP FIXING ANCHOR

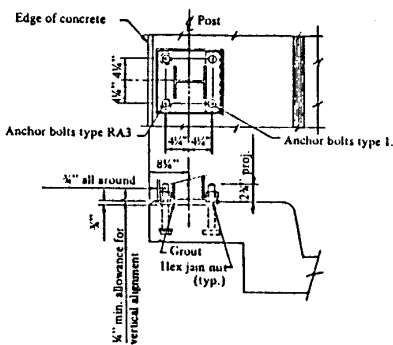

TYPICAL SIDE FIXING ANCHOR

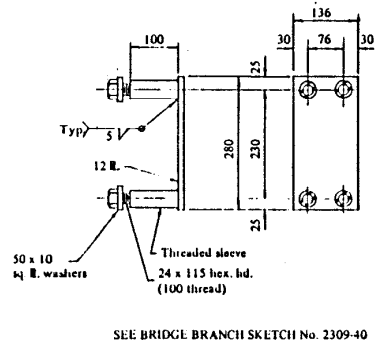

W BEAM BACK-UP PLATE

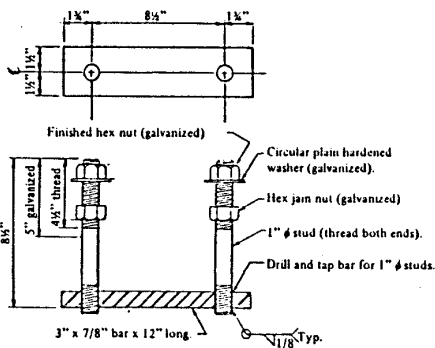
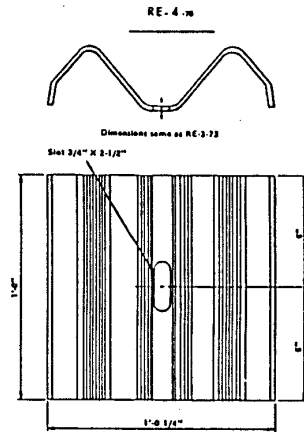

Province of British Columbia

Ministry of Transportation and Highways

Revisions

<p>STEEL POST TYPICAL DETAILS STEEL GUARDRAILS</p>	
<p>Date: 04-26-04 Approved</p> <p>MGE/ctm</p> <p>Exec. Dir. of Engineering</p>	<p>SPECIFICATION DRAWING No.</p> <p>10-SP 312</p>

CURVED RAILS

SP312-11

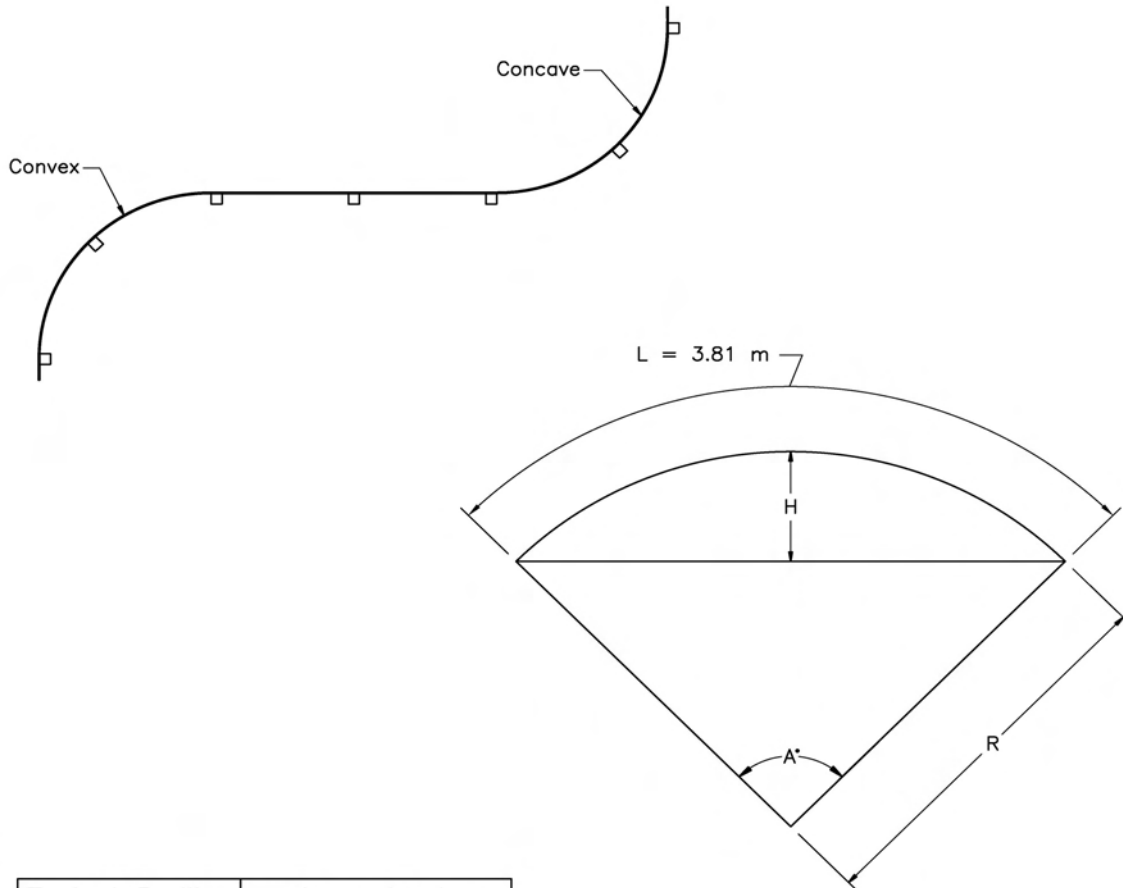

Typical Radii R (m)	Approximate A (deg) H (mm)	
1.5 (min. convex)	145	1055
3.0 (min. concave)	72	585
5.0	43	360
7.5	29	240
10.0	21	180
12.5	17	145
15.0	14	120
18.0	12	100
21.0	10	85
25.0	8	70
30.0	7	60
35.0	6	50
40.0	5	45
45.0	4.5	40

NOT TO SCALE

ALL DIMENSIONS ARE IN MILLIMETRES UNLESS OTHERWISE NOTED

SECTION 316

STEEL AND WIRE FENCE MATERIALS

316.01 Scope - This Section covers the quality and manufacture of wire fencing material, steel posts, gates and hardware, and various accessory material and the fabrication of steel tubular fencing for pedestrian and bicyclist applications.

Treated wood fence posts are specified by SS 909.

For convenience, chain link fabric necessary for protection on rock slopes is included in this Section.

The uses of materials specified in this Section are generally indicated on Drawings of the SP741 series for construction of fences and SS 207 for rock protection.

The types of Standard Wire fencing and Chain Link fabric for fencing and protection on rock slopes covered by this Section are designated as follows:

- Type A - Special Wire Fabric Fence for use only on railway rights-of-way
- Type B - Standard Wire Fabric Fence
- Type C - Standard Barbed Wire Fence
- Type D - Chain Link Fence.

Chain link fence protection on rock slopes and tentative requirements for High-tensile Smooth-wire Fences are also included.

316.02 Applicable Documents - See Table 316-A.

Note: Standards referred to in this Section are obtainable from:

CGSB: Publishing and Depository Services
Public Works and Government Services
Canada
Ottawa ON
K1A 0S5
www.tpsgc-pwgsc.gc.ca/cgsb/pubs/index-e.html

ASTM: American Society for Testing and
Materials
100 Barr Harbor Drive
West Conshohocken, PA
19428-2959
USA
<http://www.astm.org/>

316.03 Type A & B Fence Fabrics - Fence fabric for railway and highway rights-of-way shall be

manufactured from good commercial quality galvanized steel wire in general accordance with ASTM A 116, but shall conform to the requirements following and those listed in Table 316-B.

316.03.01 Styles - See Table 316-B. Length of fabric rolls shall be 101 m unless otherwise ordered.

Note: Other standard and specialty fabrics when specified shall meet the following general specifications.

316.03.02 Wire Size and Strength - All wire used in the fabric shall have a minimum galvanized coated nominal diameter of 2.50 mm (12 1/2 ga.). The variation permitted from the measured nominal diameter shall be ± 0.1 mm. The minimum breaking force shall be 4250 N.

316.03.03 Zinc Coating - The zinc used for coating shall be any grade of zinc conforming to ASTM B 6. All wire shall have a uniform coating of zinc which shall adhere firmly to the base metal. The average mass of zinc coating shall be 90 g/m² of uncoated wire surface for three specimens but minimum 80 g/m² for any individual specimen.

316.03.04 Quality of Work - Splicing of individual line wires by means of a wrap joint, electric butt weld or galvanized sleeve is permitted.

The maximum number of line wire joints shall not exceed half of the number of line wires in any roll of fencing.

All joints shall be made in accordance with good work practice.

All stay wires shall be properly spaced and substantially perpendicular to the line wires.

The locks or fastenings at the intersections of the longitudinal and vertical wires of the woven wire fencing shall be of such construction as will prevent them from slipping, either longitudinally or vertically. All locks and fastenings shall be effectively galvanized.

Horizontal wires of all woven wire fencing shall be provided with tension curves to accommodate temperature changes after erection.

316.03.05 Testing

i) Samples: Sufficient length of fabric to include at least three vertical stay wires shall be cut from each roll to be tested as required by SS 316.15 from which line wire and stay wire specimens shall be taken for testing.

ii) Diameter of coated wire: The average of two readings taken at right angles to each other at random on uniformly coated areas shall all be within the tolerance measurements specified in SS 316.03.02.

iii) Strength: The tensile strength of three line wire specimens shall be tested in accordance with ASTM A 370 on a machine calibrated to ASTM E 4 standards. The tensile strengths shall meet the requirements of SS 316.03.02.

iv) Coating adhesion: Three line wire specimens shall be wrapped in a close helix at least twice around a cylindrical mandrel having a diameter four times the nominal diameter of the wire: wrapping speed shall not exceed four seconds per turn. The coating shall adhere to the wire without flaking or being removed by rubbing with bare fingers.

v) Coating mass: Three line wire specimens (from each roll), each more than 400 mm in length, and three stay wire specimens of short lengths

between knots, etc., but each specimen totalling more than 400 mm shall be tested in accordance with ASTM A 90 for conformity with the requirements of SS 316.03.03.

vi) Rejection and Retest: Refer to SS 316.16.

316.04 Type D Fence Chain Link Fabric - Chain link fence fabric shall be manufactured from good commercial quality galvanized steel wire (or other specified finish) in general accordance with CAN/CGSB-138.1M and shall conform to the requirements listed in SS 316.04.01 through SS 316.04.04.

316.04.01 Fabric Classification (according to CGSB Standard) - The type, class, style and grade of chain link fence fabric shall be as specified on the Purchase Order, Work Order or Special Provisions in accordance with the Drawings and/or Drawings SP741-05.01 and SP741-05.02, selected from the following or as may be otherwise specified or approved.

i) Type/Class 1A - Zinc coated (galvanized) steel wire fabric normally will be specified for all heights of chain link fences as indicated on Drawing SP741-05.01, unless Type/Class 1B Vinyl coated steel is required for authorized special installations.

ii) Style - nominal diameter of zinc coated wire:

- Heavy, for highway protection fence from

TABLE 316-A DOCUMENTS APPLICABLE FOR REFERENCE

CAN/CGSB-138.1-M and 1-GP-181M	Fence, Chain Link, Fabric Coating, Zinc-Rich, Organic, Ready Mixed
ASTM A 53	Specification for Pipe, Steel, Black and Hot-Dipped, Zinc-Coated Welded and Seamless
ASTM A 90	Test Method for Weight of Coating on Zinc-Coated (Galvanized) Iron or Steel Articles
ASTM A 116	Specification for Zinc-Coated (Galvanized) Steel Woven Wire Fence Fabric
ASTM A 121	Specification for Zinc-Coated (Galvanized) Steel Barbed Wire
ASTM A 123	Specification for Zinc (Hot-Galvanized) Coatings on Products Fabricated from Rolled, Pressed, and Forged Steel
ASTM A 153	Specification for Zinc Coating (Hot-Dip) on Iron and Steel Hardware
ASTM A 641	Specification for Zinc-Coated (Galvanized) Carbon Steel Wire
ASTM B 6	Specification for Zinc (Slab Zinc)
ASTM B 211M	Specification for Aluminum-Alloy Bar, Rod, and Wire [Metric]

TABLE 316-B STYLES OF FENCES

Fence Types	Fabric Style No.	Number of Horizontal Wires	Fabric Height (mm)	Stay Wire Spacing (mm)	Wire Diameter (mm)
A	1047-6	10	1195	150	2.50 MIN
B	939-6	9	990	150	2.50 MIN

TABLE 316-C ZINC COATED WIRE

Type 1A	Style	Zinc Coated Wire Nominal Diameter	Breaking Force Minimum N
	Heavy	5.0 mm ± 0.1 mm	10 000
	Medium	3.5 mm ± 0.1 mm	5 000
	Light	3.0 mm ± 0.1 mm	3 600

TABLE 316-D VINYL COATED ZINC-COATED WIRE (when permitted)

Type 1B	Style	Vinyl Coated Zinc-Coated Wire Nominal Diameter	Breaking Force Minimum N
	Heavy	5.0 mm ± 0.1 mm	6 000
	Medium	3.5 mm ± 0.1 mm	3 000
	Light	3.0 mm ± 0.1 mm	2 600

rolling rock

- Medium, for Standard and Security height fences
- Light, for Residential height fences (see Drawing SP741-05.01)
- See Table 316-C and 316-D (when permitted).

iii) Grade - mass of zinc coating per unit area of uncoated wire: Grade 1, average 490 g/m² for three specimens, minimum 440 g/m² for any individual specimen. The zinc used for coating shall be any grade of zinc conforming to ASTM B 6. All wire shall have a uniform coating of zinc which shall adhere firmly to the base material.

Note: When specified, Grade 2 heavy coating (average 610 g/m², individual 550 g/m² minimums) for corrosive environments and the zinc coating (average 90 g/m², individual 80 g/m² minimums) for vinyl coated wire and the vinyl coating requirements shall be in accordance with CAN/CGSB-138.1M.

316.04.02 Fabric Height, Length and Mesh - Wire shall be woven throughout to a uniform diamond mesh 50 mm ± 3.0 mm clear between parallel mesh wires: fabric height as specified ± 25 mm with both selvage edges twisted and/or knuckled:

- fabric 1.5 m high and under: knuckled both edges
- fabric 1.8 m high and over: knuckled one edge, and twisted the other
- Residential height fence light style fabric 1.0 m and 1.2 m high: knuckled both edges.

Length of rolls with slack removed by nominal tensioning shall be 100 m unless otherwise ordered.

Note: Typical (normal) ordering designation from above: Type 1, Class A, Grade 1, Medium Style with roll width (height), length, mesh size and quantity.

316.04.03 Quality of Work - Fabric shall be of uniform quality and condition, free from all defects and imperfections affecting serviceability and appearance.

316.04.04 Testing

i) Samples: Three full height pickets shall be provided from each roll as required by SS 316.15.

ii) Diameter of coated wire: The average of two readings taken at right angles to each other at random on uniformly coated portions of each pair of pickets between bends shall be within the tolerance measurement specified in SS 316.04.01(ii).

iii) Strength: The tensile strength of three line wire specimens shall be tested in accordance to ASTM A 370 on a machine calibrated to ASTM E 4 standards. The tension applied to the undeformed portion between two adjacent bends shall meet the requirements of SS 316.04.01(ii).

iv) Coating adhesion: Three specimens of undeformed portions between two adjacent bends shall be wrapped in a close helix once around a cylindrical mandrel having a diameter four times the nominal diameter of the wire: wrapping speed shall not exceed four seconds per turn The coating shall adhere to the wire without flaking or being removed by rubbing with bare fingers.

v) Coating mass: Three specimens (from each roll) each more than 400 mm long excluding knuckled or twisted ends shall be tested in accordance with ASTM A 90 for conformity with the requirements of SS 316.04.01(iii).

vi) Rejection and Retest: refer to SS 316.16.

316.05 Chain Link Fabric and Accessories on Rock Slopes - Chain link fabric for protection on rock slopes shall be manufactured and tested in general conformity with SS 316.04 and to the following requirements:

- Fabric shall be to CAN/CGSB-138.1M designation of wire woven to 75 mm diamond mesh in rolls 3.0 m wide, knuckled on both selvage edges, and 15 m long. See Table 316-E.

Note: For corrosive conditions and environment Grade 2 - heavy galvanizing may be specified as a

special order with possible extended lead time required for delivery.

316.06 Barbed Wire - Barbed wire for Type B & C fences and for security height Type D fences shall be manufactured from good quality galvanized steel wire in general accordance with ASTM A 121 but shall conform to the following detail requirements:

a) Wire Size and Strength: The wire shall be continuously twisted double strand of 2.5 mm nominal diameter (12 1/2 ga.) and to have a minimum breaking force of 4000 N.

b) Barbs: Four point barbs shall be of not less than 2.0 mm nominal diameter (14 ga.) and regular 150 mm maximum spacings.

c) Zinc Coating Class (according to ASTM A 121): The zinc used for coating shall be any grade of zinc conforming to ASTM B 6. All wire, including barbs, shall have a uniform coating of zinc which shall adhere firmly to the base metal.

The average mass of zinc coating per unit area of uncoated wire for three specimens and the minimum for any individual specimens shall be in accordance with the class of coating as follows:

i) Class 1 for use in the construction of Type C fences and for the top strand of Type B fences (see Drawings SP741-01.01 and SP741-02.01), the coating shall be average 90 g/m² and 80 g/m² individual minimums.

ii) Class 3 for use with Security height Type D Chain Link fences (see Drawing SP741-05.01), coating shall be average 240 g/m² and 215 g/m² individual minimums.

d) Length: Spools shall be 400 m unless otherwise ordered.

e) Quality of Work: Splicing of individual strand wires by means of a wrap joint or an electric butt weld is permitted. Not more than three splices or joints shall exist in any 400 m spool of barbed wire. Such splices or joints shall be made in accordance

TABLE 316-E FABRIC DESIGNATION

Type 1	Class A Grade 1	Light Style	OR Nominal Diameter	Medium Style
Steel	zinc coated (galvanized)	3.0 mm		3.5 mm

with good work practice.

The twist in the double strand barbed wire shall be uniform and continuous in one direction to lock the barbs in place. The barbs shall be sharp and well formed.

Wire strands showing nicks or indentures likely to cause the wire to break under flexure are not acceptable.

f) Testing

i) Samples: Sufficient length of barbed wire shall be cut from each spool to be tested as required by SS 316.15.

ii) Strength: The tensile strength of three line wire specimens shall be tested in accordance to ASTM A 370 on a machine calibrated to ASTM E 4 standards. The tensile strength shall meet the requirements of SS 316.06 (a).

iii) Coating Mass: Three single wire specimens (from each spool), each aggregating more than 400 mm in length shall be tested in accordance with ASTM A 90 for conformity with the requirements of SS 16.06 (c).

iv) Rejection and Retest: Refer to SS 316.16.

Note: Smooth (barbless) galvanized wire, not specified to be "high-tensile," shall be double strand meeting all the above requirements except those for barbs.

316.07 High-tensile Wire - Requirements for galvanized wire for high-tensile smooth-wire (no barbs) fencing are shown in Table 316-F.

316.08 Brace, Tension and Tie Wire

316.08.01 Brace Wires - Brace wire shall be manufactured of good commercial quality soft temper steel wire 3.5 mm nominal diameter gauge and zinc

coated (galvanized) normally minimum 80 g/m² (Class 1 according to ASTM A 641) or as otherwise specified or approved.

Brace wire for high-tensile smooth-wire fencing may be fence wire specified in SS 316.07.

316.08.02 Tension Wire - Tension wire to secure bottom of chain link fencing and at top where specified shall be manufactured of good commercial quality coil spring crimped steel wire 5.0 mm nominal diameter gauge and zinc-coated (galvanized) normally 400 g/m² (Class B according to ASTM A 641) for Standard and Security height fences, or as otherwise specified or approved. Residential height fences tension wire shall be 3.5 mm nominal diameter.

316.08.03 Tie Wire and Wire Hog Ring Clips - Tie wire and wire hog ring clips shall be of steel of the nominal diameter gauge specified and zinc coated equivalent to that specified for the relevant fencing fabric: Aluminum tie wire shall be of specified gauge and according to ASTM B 211M.

316.09 Steel Fence Posts on Rock (Excluding Chain Link Fence) - Steel fence posts and braces for Type A, B and C fences where specified or required on exposed rock or rock with minimum over-burden shall be of good commercial quality steel conforming to either Category A or Category B as specified in SS 316.10 with the following exceptions:

- Line post mass shall be not less than 1.9 kg/m and angles 4.75 kg/m minimum, both drilled for attaching barbed wire or a substantial number of fence fabric line wires with wire ties or clips.
- Channel braces shall be 1.5 kg/m minimum.

316.10 Steel Pipe Posts, Rails and Braces - Chain Link Fencing

316.10.01 Category and Sizes - All posts, rails and braces shall be of Category 1 or Category 2 at the discretion of the supplier and shall be supplied in the nominal outside diameter as specified on the Purchase

TABLE 316-F REQUIREMENTS FOR GALVANIZED WIRE FOR HIGH TENSILE SMOOTH-WIRE (NO BARBS) FENCING

Diameter:	2.5 mm nominal diameter (12 1/2 ga.)
Tensile Strength:	between 1170 MPa and 1590 MPa (170,000 to 230,000 psi)
Breaking Force:	in excess of 5800 N (1300 lbf)
Zinc Coating (Class 3):	minimum 240 g/m ²
Coil Length:	in excess of 1200 m (approx. 100 lb.)

**TABLE 316-G REQUIREMENTS FOR PIPE COMPONENTS FOR
CHAIN LINK FENCING - CATEGORY A**

Pipe Sizes	Nominal Outside Diameter (mm)		
	Residential	Standard	Security
Line Posts	42	48	60
End, Corner & Straining Posts	48	60	73
Gate Posts, gates 2.5 m and less	48	60	73
Gate Posts, gates over 2.5 m	48	73	89
Top Rails	33	33	42
Brace Rails	--	33	42

Order, Work Order or Special Provisions in accordance with the Drawings and/or Drawing SP741-05.02 and selected from Tables 316-G or 316-H or as may be otherwise specified or approved.

Note: Specifications or Purchase Order may permit thin wall tubing and consequent lower zinc coating for proprietary galvanized and vinyl coated residential fence posts and gates.

Bolts and nuts for fastening braces to posts shall be galvanized Class D (305 g/m² individual pipe posts, rails and braces for chain link Type D fences shall be manufactured in general accordance with ASTM A 53.

a) Category A - Category A posts, braces and rails shall be steel butt weld pipe, Schedule 40, as specified by ASTM A 53, except that the hydrostatic testing requirement is waived, and the minimum weight shall be no less than 95% of the nominal weight. Pipe shall be zinc-coated in accordance with ASTM A 53. This ASTM Standard requires, among other things, an average zinc coating of 550 g/m² and a minimum zinc coating of 490 g/m².

b) Category B - Category B posts, braces and rails shall be made from steel pipes. The pipe shall be formed from steel strip conforming to ASTM A 569. The steel in the formed pipe shall have a minimum yield strength of 350 MPa (50,000 psi). The product of the yield strength and section modulus of the pipe shall be not less than that of pipe meeting the requirements for Category A posts and rails.

The outer surface of Category B posts, braces and rails shall have all of the following protective coatings, applied in the following order:

i) Hot dip zinc coating, conforming to ASTM B 6, High Grade or Special High Grade, applied at an average weight of 305 g/m² (1.0 oz/ft²) and at a minimum weight of 275 g/m² (0.9 oz/ft²), as determined by the test method in ASTM A 90.

ii) Chromate conversion coating, with a weight of 30 micrograms/sq. in. ±15 micrograms/sq.in., as determined by a strip and weight method for the zinc and chromate and by determining the percentage of each by atomic absorption spectrophotometer.

iii) Clear acrylic polyurethane coating with a thickness of 0.100 mm ± 0.025 mm (0.4 ± 0.1 mils).

The combined outer coating shall have an ability to resist:

- 1000 hours of exposure to salt fog with a maximum of 5% red rust when tested in accordance with ASTM B 117.
- 500 hours of exposure to 100% relative humidity without blistering and peeling when tested in accordance with ASTM D 2247; and
- 500 hours of exposure in a weatherometer without film cracking of the clear coat when tested in accordance with ASTM G 23, Type E or EH carbon arc, or ASTM G 26, Type B or BH xenon arc.

The inner surface of Category B, posts, braces and rails shall have either a zinc coating as per ASTM F 1234, Type B, applied at an average rate of 305 g/m² and a minimum rate of 275 g/m²; or an ASTM F 1234, Type D zinc coating with a minimum zinc powder loading of 91% by weight

SECTION 316

STEEL AND WIRE FENCE MATERIALS

and a minimum thickness of 0.075 mm (0.3 mils). The inner coating shall have an ability to resist 650 hours of exposure to salt fog with a maximum 5% red rust when tested in accordance with ASTM B 117.

316.10.02 Quality of Work - The finished pipes shall be reasonably free from injurious defects. All burrs at ends of pipes shall be removed.

The zinc or zinc/chromate/acrylic coating shall be free from injurious defects and excessive roughness.

316.10.03 Testing

a) Samples: A 100 mm specimen shall be cut from each end of one pipe in every lot of 500 or fraction thereof.

Note: Specimens may be taken from the extreme ends of pipe that has been cut to length after galvanizing; otherwise, specimens shall be taken at least 200 mm clear of each galvanized end build-up.

b) Dimensions: Specimens shall be measured for diameter and wall thickness/mass and all shall be within the tolerance measurements specified by SS 316.10.01.

c) Mass Coating: Specimens shall be tested for the mass of zinc or composite coating in accordance with SS 316.10.01 and ASTM A 90.

d) Rejection and Retest: Refer to SS 316.16.

316.11 Gates and Hardware - Gates shall be supplied with hardware ready for installation as specified by the Purchase Order, Work Order or Special Provisions in accordance with the Drawings and/or Drawings SP741-04.04, SP741-04.05, SP741-05.03 and SP741-05.04 or as may be otherwise specified or ordered.

Gates may be specified by the types as follows:

- **Type I** Pressed sheet steel frame, in-fill and brace members
- **Type II** Pipe frame and horizontal pipe in-fill members
- **Type III** Pipe frame, bracing and wire fabric in-fill
- **Type IV** Pipe frame, bracing and chain link fabric in-fill
- **Type V** Slip wire range gates barbed wire and wood droppers

with the general requirements of material, finish, hardware and quality of work specified in SS 316.11.01 through SS 316.11.06.

316.11.01 General - Gate sizes shall be the fence height or as otherwise stipulated and the nominal width designated by the clear opening width between gate posts with allowance made for hinges and latches, etc.

Gates shall be fabricated of galvanized pipe, tubing or formed sheet metal sections properly joined, braced and with in-fill all as specified by type below.

All pipe joints shall be cut to fit closely together and fully welded, vertical stiles neatly capped or mitred to horizontals with drilled holes to vent and drain closed end pipe members. Bends where permitted at corners shall be made without deforming tube or pipe section.

All welds, conforming to the best commercial practice, shall be smooth, and with adjoining and other marred galvanized pipe surfaces, shall be painted with two heavy coats of zinc rich paint manufactured in accordance with Standard 1-GP-181M.

All hardware and required fittings and fasteners shall be of suitable aluminum alloy or of steel or malleable or ductile cast iron, galvanized in accordance with ASTM A 153. Hinges generally shall be so designed as to permit the gate to swing back against the fence and to prevent the easy removal of gate and hinges. Hinges and other fittings shall all be of adequate strength for fastening securely without distortion and shall be sound and free of defects. Chain and/or latching gate catch for padlocking together with

TABLE 316-H REQUIREMENTS FOR PIPE COMPONENTS FOR CHAIN LINK FENCING - CATEGORY A

Actual Outside Post Diameter (mm)	26.7	33.4	42.1	48.3	60.3	73.0	88.9
Wall Thickness (mm)	2.87	3.38	3.56	3.68	3.91	5.16	5.49
Mass (kg/m)	1.7	2.5	3.4	4.0	5.4	8.6	11.3
Tolerances:	Diameter ± 1%			Mass ± 5%			

keepers to hold the gate open and centre drop bolt and sleeve for double swing gates shall be provided as and where specified or ordered.

All galvanizing and other finished surfaces shall be smooth and free of sharp dangerous protrusions.

316.11.02 Type I Gate (sheet metal members) -

Formed heavy duty galvanized sheet metal sections with rolled edges as horizontal rails and vertical stiles, braced vertically and/or diagonally with similar members as necessary shall be rigidly riveted together to form a rugged non-sagging prefabricated gate.

Nominal sizes:

- 1220, 2440, 3050, 3660, 4270 and 4880 mm wide; and
- 1220 mm high.

Gates to be supplied completely assembled with required hardware for wood (or metal) gate posts all as specified or ordered.

316.11.03 Type II Gates (all pipe) - Galvanized pipe 42 mm OD, 3.4 kg/m mass with zinc coating minimum 490 g/m² (see SS 316.10.01 and SS 316.10.03) shall be welded together as gate frame and horizontal pipe in-fill members at 305 mm on centres. Vertical centre bracing of 5 mm x 19 mm flat bar on both sides of all horizontals is not required for gates 3050 mm and 3660 mm nominal widths. Gussets shall be welded to opposite corners of the gate as shown on Drawing SP741-04.05.

Nominal sizes:

- 3050, 3660, 4270 and 4880 mm wide; and
- 1220 mm high.

Gates shall be supplied completely assembled with required hardware for wood (or metal) gate posts all as specified or ordered.

316.11.04 Type III Gates (pipe and fabric) -

Galvanized pipe 33 mm OD, 2.5 kg/m mass with zinc coating minimum 490 g/m² (see SS 316.10.01 and SS 316.10.03) shall be formed with even radius bent corners or neatly welded corners and vertical bracing at 1/3 points in the width of 27 mm OD, 1.7 kg/m pipe. Cleats or gussets shall be welded to opposite corners of gate frame/panel(s) as indicated on Drawing SP741-04.05, holed for securing under tension a diagonal brace consisting of 5.0 mm nominal diameter galvanized coil spring wire (see SS 316.08) with or without forged turn-buckle as and when specified or ordered.

In-fill shall be wire fabric all of 3.5 mm galvanized diameter wire with seven or more horizontal line wires, and stay wires not more than 600 mm apart. Fabric shall be securely fixed taut without sag to gate frame all round and to vertical brace in an approved manner.

Nominal sizes:

- 3050, 3660, 4270, 4880 and 5490 mm wide; and
- 1070 and 1220 mm high.

Gates shall be supplied completely assembled with required hardware for wood (or metal) gate posts all as specified or ordered.

316.11.05 Type IV Gates (pipe and chain link) -

Gate frame and required vertical bracing and/or diagonal bracing to cleats all welded as generally indicated on Drawing SP741-05.04 for hinged swing gates shall be fabricated to the designated size(s) complete with chain link in-fill and hardware for fixing to metal posts all as detailed, specified or ordered.

Pipe shall be in accordance with SS 316.10 and welding with SS 316.11.01. In-fill of chain link fabric as specified for fencing (see SS 316.04), shall be attached to gate frame stiles with tension bars and bands (see SS 316.12), and to horizontal members and vertical bracing with tie wire (see SS 316.08.03), all taut and sag free.

Sliding gates may be specified for gate openings over 4.0 m and shall be fabricated as generally indicated for swing gates but with diagonal tension rod bracing to support centre from both ends. The rolling hardware shall hold the gate vertical and parallel to the gate posts and adjoining fence at all times to allow free operation from any position while not retained by latches or keepers.

Roller assembly sheaves and wheels with bearings, grease fittings, necessary clamps, supports and fasteners, and chain and/or latching gate catch for padlocking, all of approved design, shall be provided as and when specified or ordered.

316.11.06 Type V Gates (range slip wire) - Barbed wire continued across standard width gate opening (for possible future farm gate) with 50 mm diameter full fence height treated wood droppers securely figure of eight wire tied and stapled to each line wire shall be provided with a galvanized steel strap loop at bottom and either similar loop at top with an intermediate chain (for padlocking) or, when specified, a Princeton or other approved cinch-up lockable latch device all for

SECTION 316

STEEL AND WIRE FENCE MATERIALS

securely attaching to fence or gate posts to hold open-end dropper.

316.12 Accessory Material - All required fittings, fasteners, hardware and accessories shall be of suitable aluminum alloy or steel, malleable or ductile cast iron, and galvanized in accordance with ASTM A 153, or as may be otherwise specified and/or ordered.

a) Staples for securing wire and fabric to treated wood fence posts shall be nominal 3.5 mm diameter steel wire with a driving length of at least 45 mm heavy galvanized finish.

b) Hog ring clips for securing wire fabric and/or barbed wire of Type A, B and C Fences to steel posts and to tension wire of Type D Fences see SS 316.08.03.

c) Dowel, Spikes, Bolts and Nuts shall be of good commercial quality, galvanized where specified or ordered.

d) Metal Droppers for high-tensile fencing will be prefabricated "Waratah" or other acceptable galvanized formed sheet metal droppers, 1070 mm for 5-wire and 1170 mm long for 6-wire fences, with preformed wire clips: such metal droppers or other acceptable manufacture may be specified or permitted as an alternative to the wood droppers specified by SS 909.08 for barbed wire (Type C) fences.

Note: Galvanized twisted double wire fence stays are permitted only for the extension of normal fence heights to deer height and the like.

e) All terminal and tensioning posts, for Type D chain link fences, shall be provided with aluminum or galvanized weather tight caps to fit and fasten securely and with extended arms for engaging barbed wire of security fences.

f) Caps for line posts for Type D chain link fences, shall carry top rail. Rail and brace end caps shall be provided for securing to rails and bolting with steel bands to posts.

g) Tension Bars for securing chain link fencing to terminal and tensioning posts and to vertical stiles of gates of Type D Fences shall be merchant quality mild steel strip 5 mm x 19 mm in minimum lengths of 50 mm less than full height of the chain link fabric, hot dip galvanized.

h) Tension and Brace Bands for securing brace and top rail caps and tension bars to posts shall be formed of minimum 2.5 mm x 19 mm mild steel strip, hot dip galvanized complete with bolt and nut.

i) Tensioning Devices for individual in-line high-tensile wire will be "Hayes" or other acceptable manufacture and operation.

j) Mechanical Splices and Fasteners shall be of "Nicopress FW2-3" or other acceptable manufacture applicable to the respective diameter and tensile strengths of wires.

316.13 Packaging and Marking - Each roll of fencing fabric or chain link mesh and spool of wire shall be tightly rolled and firmly tied to prevent loosening during shipment and handling.

Posts shall be securely fastened in bundles or sets, and accessories packaged in cartons or other suitable containers, to prevent loss or damage during shipment and handling.

Each product, roll, bundle or container etc., shall be clearly marked with the name, brand and/or trade mark of the manufacturer; the heat or lot number and other information sufficient to identify the style, type, class, grade, finish, height and/or length, nominal or outside diameter, gauge and the applicable Standard to which the product conforms.

316.14 Inspection - No material shall be shipped prior to inspection or until a release for shipment has been issued by the Ministry Representative.

All material may be inspected before shipment to the construction site or at the construction site, or both. The Supplier or manufacturer shall provide the necessary facilities to enable the Ministry Representative to expeditiously examine selected pieces from the material lot(s) clearly identified for intended supply to the Ministry. Identification shall be such that after inspection and testing the lot(s) may be subsequently identified for acceptance or rejection.

Inspection of material before shipment shall not exclude its subsequent rejection at the construction site if found to fail any requirements of this specification.

316.15 Sampling - One roll of fabric or spool of wire, in every lot of 50 or fraction thereof, in the shipment may be selected at random for testing but in no case will less than two samples be tested.

Specimens for testing will be required from the outside ends of the selected sample roll or spool material and both ends of one post in every 500 or fraction thereof.

Sufficient length of each roll, spool or pipe shall be taken to provide the number of specimens for each of the testing requirements specified.

Wire used for knots, knuckling, twisting and wraps and wire containing welds shall be excluded from tests.

See respective material tests for pertinent sample lengths.

316.16 Rejection and Retests - If any tested specimen fails to meet the testing requirements specified above, the roll, spool or pipe represented by the specimens shall be replaced with two additional rolls, spools or pipes selected by the Ministry Representative and both shall meet the test requirements in every respect, otherwise the complete lot represented by the samples will be subject to rejection.

In the event of complete lot rejection and prior to any further testing by the Ministry, the intended replacement lot(s) shall be satisfactorily tested by a mutually acceptable independent testing agency at no expense to the Ministry: where the time delay for retesting is unacceptable to the Ministry the order or

part thereof will be subject to cancellation.

Rejected material shall be replaced at the Supplier's or Contractor's expense including shipping charges and removal of rejected material at the construction site, if applicable.

316.17 Steel Sidewalk Fence - Steel pedestrian and bicyclist sidewalk fence material shall be installed in accordance with the requirements of the BC Supplement to TAC Geometric Design Guide, the Drawings and the details provided on SP741-07.01 and SP741-07.02. All steelwork shall be fabricated in accordance with SS 422. All field welded railing connections shall conform to the requirements of SS 422.

If the 'swaged' detail shown on SP741-07.03 is proposed as an alternative, the Contractor shall provide the Ministry Representative with satisfactory test results from an accredited testing agency for the following test procedures:

- Flattening test in accordance with ASTM A 370
- Whole body tensile test in accordance with ASTM A 370
- Strain age embrittlement test in accordance with CSA C83 @-45°C

SECTION 317

P.E. PLASTIC DRAINAGE PIPE

317.01 Scope This specification covers the requirements for polyethylene plastic pipe products to be used for storm sewers, pipe culverts, and subdrains. This specification covers non-pressure polyethylene plastic pipe with nominal pipe diameters of 100mm through to 900mm.

317.02 Applicable Documents This specification refers to the following Standards, specifications or publications:

Canadian Standards Association:

CSA B182.8 – Profile Polyethylene Storm Sewer and Drainage Pipe and Fittings

American Society for Testing Materials:

ASTM D883: Standard Terminology Relating to Plastics

ASTM D2122: Standard Test Method for Determining Dimensions of Thermoplastic Pipe and Fittings

ASTM D2412: Standard Test Method for Determination of External Loading Characteristics of Plastic Pipe by Parallel-Plate Loading

ASTM D2444: Standard Test Method for the Determination of Impact Resistance of Thermoplastic Pipe and Fittings by means of Tup (Falling Weight)

ASTM D3212: Specifications for Joints for Drain and sewer plastic Pipes Using Flexible Elastomeric Seals

ASTM F405: Standard Specification for Corrugated Polyethylene (PE) Pipe and Fittings

ASTM F667: Standard Specification for Large Diameter Corrugated Polyethylene Pipe and Fittings

ASTM D3350: Standard Specification for Polyethylene Plastic Pipe and Fittings Materials

American Association of State Highway and Transportation Officials:

AASHTO M252: Corrugated Polyethylene Drainage Tubing

AASHTO M294: Corrugated Polyethylene Pipe, 12- 36-in. Diameter

317.03 Definitions For the purpose of this specification the following definitions apply:

Polyethylene Plastic: means a plastic based on polymers made with ethylene as essentially the sole monomer.

Corrugated Inner Wall Pipe: means a single walled pipe product with a corrugated inner waterway where the wall is formed into a series of alternating ridges and grooves.

Profile: means a pipe wall construction that presents an essentially smooth surface in the waterway but includes ribs or other shapes, which can be either solid or hollow, that help brace the pipe against diametrical deformation.

Open Profile Pipe: means a pipe product that has an essentially smooth waterway braced circumferentially or helically with outside corrugations, forming an open profile pipe.

317.04 Pipe Types and Materials The pipe, fittings and couplers shall be manufactured from virgin polyethylene plastic for the type of polyethylene pipe.

317.05 Joining Systems

317.05.01 Flexible Subdrain Tubing Couplings shall conform to the requirements of ASTM F405 (100mm – 150mm) or ASTM F667 (200mm – 600mm)

Type	Profile	Materials (See Note 1)
Flexible Subdrain Tubing	Corrugated Inner Wall	The moulding and extrusion material for pipe and fittings shall be polyethylene plastic according to the requirements of ASTM F405 or ASTM F667.
Flexible Culvert	Corrugated Inner Wall	The moulding and extrusion material for pipe and fittings shall be polyethylene plastic according to the requirements of AASHTO M252 or AASHTO M294.
Smooth Inner Wall Culvert or Storm Sewer	Open Profile	The moulding and extrusion material for pipe and fittings shall be polyethylene plastic according to the requirements of CSA B182.8 for open profile pipe.

Note (1) Clean, rework PE material generated from the manufacturer's own production of pipe, fittings, or accessories shall be permitted to be recycled by the manufacturer in the respective product, provided that the pipe, fittings, or accessories produced meet all of the requirements of the respective standards. Post-consumer recycled plastic resin shall not be used as a component of the HDPE compound during pipe manufacture.

SECTION 317

P.E. PLASTIC DRAINAGE PIPE

317.05.02 Flexible Culvert Couplings shall conform to AASHTO M252 (100mm – 250mm) or AASHTO M294 (300mm – 900mm)

317.05.03 Smooth Inner Wall Culvert or Storm Sewer Joining system for open profile pipe shall conform to the requirements of CSA B182.8. Couplings shall be specified as non-gasketed corrugated external split couplings, or integral bell and gasket. Non-gasketed double bell snap type couplings are only permitted for 100mm to 200mm diameters.

Integral bell and gasket joint shall be comprised of an elastomeric vulcanized rubber gasket provided on the spigot end of the pipe residing in the corrugation valley or crest of the corrugation. Joint shall be certified by CSA to meet to leakage requirements of ASTM D 3212.

Foam type gaskets shall not be permitted.

317.06 Requirements

317.06.01 Quality of Work – The pipe shall be homogenous throughout and free from visible cracks, flaws, foreign inclusions or other injurious defects. The pipe shall be uniform in colour, opacity and other physical properties

317.06.02 Pipe Diameter

a) Nominal Diameter – shall be the average inside diameter rounded to the nearest whole number (mm).

b) Inside Diameter – the permissible inside diameter tolerances shall be +3% and –1.5%. Measurements shall be taken in accordance with ASTM D 2122.

317.06.03 Length Laying length shall be 6m for all diameters otherwise specified on the Purchase Order, Work Order or Drawings. A tolerance of +/- 25mm on the nominal laying length will be permitted.

317.06.04 Pipe Stiffness The minimum pipe stiffness shall be:

a) Flexible Subdrain Tubing: 210kPa at 5% when tested in accordance with ASTM D 2412.

b) Flexible Culvert: 210kPa at 5% when tested in accordance with ASTM D 2412.

c) Smooth Inner Wall Culvert or Storm Sewer: 320kPa at 5% when tested in accordance with ASTM D 2412. Pipe stiffness shall be documented on the CSA Plant Certificate for the appropriate pipe diameters.

317.07 Markings All pipe shall be clearly marked at intervals of no more than 1.5m with 5mm or larger letters with the following information:

- Manufacturer's name or trademark
- Nominal diameter
- Material designation and cell class: 322420C
- The words "Drainage" or similar
- Pipe stiffness: (ie. 320 kPa)

- The applicable Specification designation (ie. CSA B182.8)
- Date of manufacture and plant designation

For Smooth Inner Wall Culvert or Storm Sewer, the pipe shall be embossed with the CSA Trademark confirming the product is certified by the Canadian Standards Council.

317.08 Quality Assurance Testing

a) The supplier shall develop and maintain an effective quality control system to ensure that adequate inspection coverage is maintained throughout the manufacturing process. Evidence of such inspection shall be available to the authorized inspector of the Ministry prior to shipment from the place of manufacture or the supplier's storage facility.

b) The Ministry reserves the right to maintain surveillance over the Supplier's quality control system to ensure conformance with this specification.

317.09 Physical Properties the physical properties of corrugated HDPE pipe such as impact strength, pipe flattening and other tests shall meet these requirements for:

a) Flexible Subdrain Tubing – ASTM F 405 or ASTM F 667

b) Flexible Culvert - AASHTO M252 or AASHTO M294

c) Smooth Inner Wall Culvert or Storm Sewer – Certified to CSA B182.8 for open profile pipe.

317.10 Certificate

a) Flexible Subdrain Tubing and Flexible Culvert: Suppliers shall provide a certificate upon request to indicate that the product was produced and tested according to the appropriate specification requirements.

b) Smooth Inner Wall Culvert or Storm Sewer: The supplier shall provide, upon request from the Ministry Representative, a copy of the CSA Plant Certificate indicating the plant location, pipe sizes, pipe stiffness and pipe joining systems.

317.11 Inspection

a) The Ministry Representative shall have access to the fabrication plant for inspection and every facility shall be extended for this purpose.

b) Inspection may include checks on physical dimensions and general quality of work.

c) For the purpose of sampling for SS 317.06 and SS 317.09, one piece from each lot of 50 pipes or fraction thereof in a shipment shall be selected for sampling. All test specimens shall be cut from the selected pipe(s).

d) If the test sample fails to meet the requirements of SS 317.06 when tested in accordance with SS 317.09, that batch will be rejected and shall be replaced by the supplier with a new batch that conforms to this specification at no additional cost to the Ministry

SECTION 318

PVC PLASTIC DRAINAGE PIPE

318.01 Scope - This Section covers the requirements and methods for testing for:

- Type PSM* Poly Vinyl Chloride Drainage Pipe
- Profile Poly Vinyl Chloride Drainage Pipe

and the perforation requirements of type PSM pipe up to a nominal diameter of 375 mm.

Note: The term PSM* is not an abbreviation but rather an arbitrary designation for a product having certain outside dimensions.

318.02 Applicable Documents

CSA B182.2: Large-diameter, Type PSM PVC Sewer Pipe and Fittings

CSA B182.4: Large-diameter, Profile PVC Sewer Pipe and Fittings

ASTM D 883: Definition of Terms Relating to Plastics

ASTM D 1784: Standard Specification for PVC and CPVC Compounds

ASTM D 2122: Standard Method of Determining Dimensions of Thermoplastic Pipe and Fittings

ASTM D 2152: Standard Test Method for Quality of Extruded PVC and CPVC Compounds

ASTM D 2412: Test for External Loading Properties of Plastic Pipe by Parallel-Plate Loading

ASTM D 2444: Standard Test Method for Impact Resistance of Thermo-plastic Pipe and Fittings by Means of a Tup (Falling Weight)

ASTM D 3034: Standard Specification for Type PSM PVC Sewer Pipe and Fittings

ASTM D 3212: Standard Specification for Joints for Drain and Sewer Plastic Pipes Using Flexible Elastomeric Seals

ASTM F 412: Definition of Terms Relating to Plastic Piping Systems

ASTM F 477: Standard Specification for Elastomeric Seals for Joining Plastic Pipe

ASTM F 794: Standard Specification for PVC Large-diameter Profile Gravity Sewer Pipe and Fittings Based on Controlled Inside Diameter.

318.03 Materials - The pipe shall be made of PVC plastic having a cell classification of 12454, or 12364, as defined in ASTM D 1784.

The fittings shall be made of PVC plastic and shall have a cell classification of 12454, or 13343, as defined in ASTM D 1784.

Elastomeric gaskets shall comply with the requirements of ASTM F 477.

318.04 Quality of Work - The pipe shall be homogenous throughout and free from visible cracks, flaws, foreign inclusion, or other injurious defects. The pipe shall be uniform in colour, opacity and other physical properties.

318.05 Joining System - All sizes of pipe shall be supplied with Elastomeric Gasket Joints providing a watertight seal in accordance with ASTM D 3034 and ASTM D 3212.

a) Integral Bell Gasketed Joints shall be designed so that when assembled, the gasket shall be compressed radially on the pipe spigot or in the bell to form a watertight seal.

b) The joint shall be designed to avoid displacement of the gasket, when assembled in accordance with the manufacturer's recommendation.

c) Joint assembly shall be in accordance with the pipe manufacturer's recommendations.

Note: Manufacturers wishing to supply pipe joining systems other than those listed under this specification shall submit details to the Ministry Representative for approval prior to the awarding of the contract.

318.06 Requirements

318.06.01 Length - Laying length shall be 4 m or 6 m for all diameters unless otherwise specified by the Purchase Order, Work Order or Drawings. A tolerance of ± 25 mm on the nominal laying length will be permitted.

318.06.02 Type PSM, PVC Drainage Pipe Dimensions - The average outside diameter and the minimum wall thickness of Type PSM PVC drainage pipe shall be as specified in Table 318-A when measured in accordance with ASTM D 2122.

318.06.03 Profile, PVC Drainage Pipe Dimensions - The average inside diameter and minimum wall thickness of Profile PVC drainage pipe shall be as specified in Table 318-B when measured in accordance with ASTM D 2122.

318.06.04 Perforations - Perforated pipe up to the nominal diameter of 375 mm shall be type PSM and perforated in accordance with Figure I and Table 318-C.

The perforations shall be 8 to 10 mm in diameter, circular, and cleanly cut. The gasketed bell and spigot end of the pipe shall be unperforated for a length equal to the depth of the socket and/or shoulder.

TABLE 318-A PIPE DIMENSIONS - TYPE PSM

OUTSIDE DIAMETER (mm)					
NOMINAL DIAMETER (mm)	AVERAGE	TOLERANCE	MINIMUM	MAXIMUM	MINIMUM WALL THICKNESS
100	107.06	± 0.22	106.84	107.28	3.06
150	159.38	± 0.28	159.10	159.66	4.55
200	213.36	± 0.30	213.06	213.66	6.10
250	266.70	± 0.38	266.32	267.08	7.62
300	317.50	± 0.46	317.04	317.96	9.07
375	388.62	± 0.58	388.04	389.20	11.10
450	475.00	± 0.70	474.30	475.70	13.57
525	560.00	± 0.85	559.15	560.85	16.00
600	630.00	± 0.95	629.05	630.95	18.00
675	710.00	± 1.05	708.95	711.05	20.29

TABLE 318-B PIPE DIMENSIONS PROFILE

INSIDE DIAMETER (mm)						
NOMINAL DIAMETER (mm)	AVERAGE	TOLERANCE	MINIMUM	MAXIMUM	DUAL WALL	MINIMUM WATERWAY WALL THICKNESS
450	448.31	± 1.41	446.90	449.72	2.13	3.30
525	527.05	± 1.50	525.55	528.55	2.41	4.06
600	596.90	± 1.78	595.12	598.68	2.79	4.58
675	673.10	± 2.00	671.10	675.10	3.05	5.20
750	749.30	± 2.30	747.00	751.60	3.3	5.96
900	901.70	± 2.70	899.00	904.40	3.94	7.36
1000	1003.30	± 3.00	1000.30	1006.30	5.08	8.26
1200	1206.50	± 3.55	1202.95	1210.95	5.08	10.16

318.07 Service Connections (and or Branches)**318.07.01 Type PSM**

a) Injection Molded PVC Gasketed Fittings meeting ASTM D3034 and certified to CSA B182.2.

b) Fabricated PVC Gasketed Fittings meeting ASTM D3034 and certified to CSA B182.2.

c) Insertable Tees complete with rubber boot.

318.07.02 Profile

a) Fabricated PVC Gasketed Fittings meeting ASTM F794 and Certified to CSA B182.4

b) Insertable Tees complete with rubber boot.

318.08 Physical Properties

318.08.01 Impact Strength - The minimum drop weight impact strength for pipe shall meet the requirements of Table 318-D when tested in accordance with SS 318.10.01.

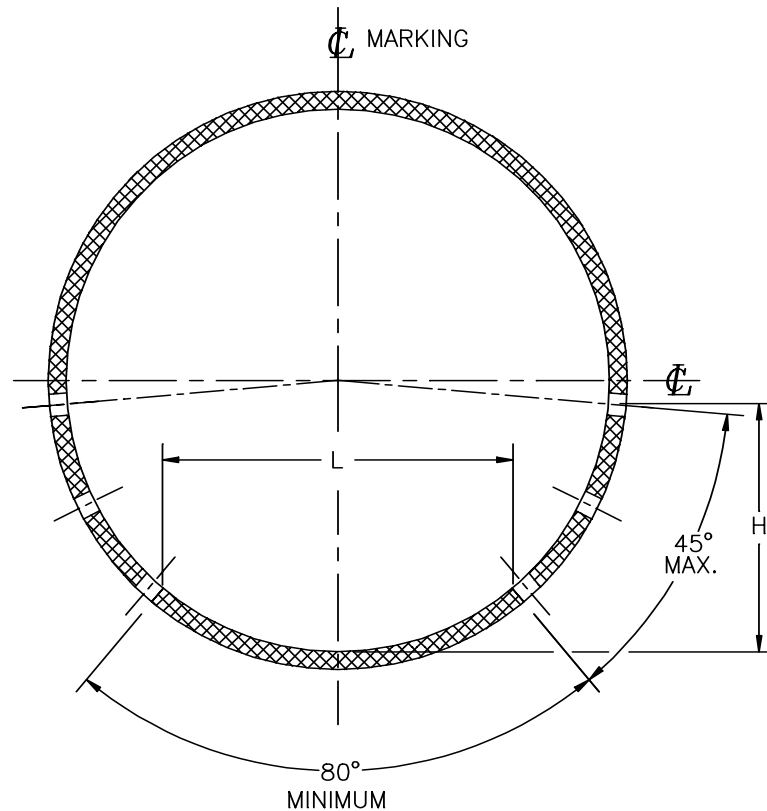

FIGURE I

TABLE 318-C PERFORATION REQUIREMENTS

NOMINAL DIAMETER (mm)	MINIMUM ROWS OF PERFORATIONS	HORIZONTAL HOLE SPACING (mm)	H (mm) *	L (mm) **
100	2	<u>75+ 5</u>	30	65
150	4	<u>75+ 5</u>	70	73
200	4	<u>75+ 5</u>	93	130
250	4	<u>75+ 5</u>	115	163
300	6	<u>150+ 5</u>	140	195
<u>375-1200</u>	<u>6</u>	<u>150+ 5</u>	<u>175</u>	<u>240</u>

*H: maximum height of the centreline of the uppermost perforations above the Invert.

**L: minimum length of the unperforated inner surface at the bottom of the pipe.

318.08.02 Pipe Stiffness - The minimum pipe stiffness when tested in accordance with SS 318.10.02 and ASTM D 2412 shall be 320 kPa.

318.08.03 Pipe Flattening - There shall be no evidence of splitting, cracking or breaking when the pipe is tested in accordance with SS 318.10.03.

318.08.04 Extrusion Quality - The pipe shall not flake or disintegrate when tested in accordance with ASTM D 2152.

TABLE 318-D IMPACT STRENGTH AT 0°C

NOMINAL DIAMETER (mm)	joules	ft. / lb.
100	<u>135</u>	<u>100</u>
150	<u>165</u>	<u>122</u>
200	175	129
250	190	140
300	205	151
375	230	170
450 and larger	250	184

318.09 Marking - All pipe shall be clearly marked at intervals of no more than 1.5 m with 5 mm or larger letters with the following information:

- Manufacturer's name or trademark
- Nominal diameter
- Material designation and cell class: PVC-12454 or 12364
- The word "Drainage" or similar
- The class: PS320
- The applicable specification designation (ASTM D 3034 or F 794)
- Date of manufacture and plant designation

The marking on perforated pipe shall be 180° from a point equidistant between the bottom row of holes as shown in Figure I and Table 318-C.

318.10 Test Methods

318.10.01 Impact Resistance - Five specimens, each nominally 150 mm long for the PSM pipe and 300 mm long for the Profile pipe, shall be tested in accordance with ASTM D 2444, using a 15 kg Tup "A" and the flat plate holder "B". The height of the drop shall not be less than 600 m or more than 3 m. The test shall be performed at 0°C (± 0.5°C), allowing no more than 15 seconds to complete the test after removing the sample from the conditioning medium. Perforated samples shall be positioned as shown in Figure I. Any cracking or other signs of material fatigue evident after the test shall constitute a failure. All five specimens must pass. If one

specimen fails, five more specimens shall be tested. Nine out of ten specimens passing will be acceptable.

318.10.02 Pipe Stiffness - The pipe stiffness shall be determined at 5% deflection of the initial inside diameter in accordance with ASTM D 2412. Three specimens, each with a length equal to one pipe diameter shall be tested; all shall meet the required stiffness. Perforated samples shall be positioned as shown in Figure I.

318.10.03 Pipe Flattening - Three specimens, each nominally 150 mm long, shall be flattened between parallel plates in a suitable press until the distance between the plates is 40% of the original nominal diameter of the pipe. The loading rate shall be uniform and such that the compression is completed within two to five minutes. Remove the load and examine the specimen. All three specimens shall meet the requirements.

318.10.04 Pipe Dimensions - Measurements shall be taken in accordance with ASTM D 2122.

318.11 Inspection

a) The Ministry shall have access to the fabrication plant for inspection and every facility shall be extended for this purpose.

b) Inspection may include checks on physical dimensions and the quality of work.

c) For the purpose of sampling for SS 318.08 and SS 318.10, one pipe from each lot of 50 pipes or fraction thereof in a shipment shall be selected for sampling. All test specimens shall be cut from the selected pipe(s).

d) If a test sample fails to meet the requirements of SS 318.07 when tested according to SS 318.10, that batch will be rejected and shall be replaced by the Supplier with a new batch that conforms to this specification at no additional cost to the Ministry.

318.12 Quality Assurance

a) The Supplier shall develop and maintain an effective quality control system to ensure that adequate inspection coverage is maintained throughout the manufacturing process. Evidence of such inspection shall be available to the authorized inspector of the Ministry prior to shipment from the place of manufacture or from the Supplier's storage facility.

b) The Ministry reserves the right to maintain surveillance over the Supplier's quality control system to ensure conformance with this specification.

SECTION 320

CORRUGATED STEEL PIPE

320.1 General - The Section covers the material and fabrication requirements for corrugated steel pipe, spiral rib pipe, and structural plate corrugated steel pipe products for applications such as culverts, storm sewers, sanitary sewers, subdrains, ground recharge systems, well casings, underpasses, stream enclosures, shelters, and tunnels.

Abbreviations for the various types of metal pipe are as follows:

CSP - Corrugated Steel Pipe

SPCSP - Structural Plate Corrugated Steel Pipe

320.2 Supply and Fabrication

320.2.1 Standards - The supply and fabrication of Corrugated Steel Pipe (CSP) and Structural Plate Corrugated Steel Pipe (SPCSP) including couplers and appurtenances shall be in accordance with the CSA Standard G401.

This specification is available on-line, free of charge, courtesy of the Corrugated Steel Pipe Institute at www.cspi.ca

320.6 Quality of Work

320.6.1 Inspection – Products shall be made available for inspection and acceptance at the point and time of incorporation into the Work.

320.6.2 Quality Management - The manufacturer shall establish the quality control plan and demonstrate its implementation. The purchaser’s Quality Management Plan shall incorporate measures to assure the quality of the materials supplied by the manufacturer.

320.6.3 Quality Assurance Testing – Minimum QA tests and inspection shall be per the following Table.

TABLE 320-A: QUALITY ASSURANCE TASTING

Element	Description	Minimum QA Testing / Inspection Frequencies	CSA Standard G401-06 Clause No.
Manufacturer’s QC	Demonstration of effectiveness	For each Designated Supplier (for over \$200,000) : Once per Contract	6
Material	Mill Certificate	1 per Contract	3.1.2.2; 8.3
	Mill Markings	1 per Contract and one additional per load of material delivered	3.2.3
Fabrication	Thickness	1 per Contract per product	CSP: Table 2 SPCSP: Table 3
	Corrugation profile	Visual each piece, plus measurements of 1 per Contract and one additional per load of material delivered	CSP: Table 5 SPCSP: Table 6
	Circumference	1 per Contract per product	CSP: Table 9
	Lock seam	For Contracts with 10 or more pieces supplied: 1 per Contract	4.1.3.4
	Perforation size	1 per shipment	4.1.5
Coating	Type	Visual, each pipe or plate	
	Thickness	For each material coating specified: 1 per Contract and one additional per load of material delivered	
	Staining or damage	Visual, each piece	7.2
	Damage Repair	Each	5.1; 5.2
Couplers	Type	Visual, each piece	4.1.7
SPCSP	Drawing and Plate Identification	Each installation	4.2.7

THIS PAGE IS LEFT INTENTIONALLY BLANK

SECTION 321

TRAFFIC PAINT

321.01 Scope - This Section applies to paint suitable for spray application at a temperature of $50^{\circ}\text{C} \pm 5^{\circ}\text{C}$ to asphalt or concrete pavements for marking of traffic lines. It will be used with overlay glass reflectorized beads, and will be supplied in white or yellow without any "pre-mix" beads.

321.02 Not Used

321.03 General Requirements - The composition of the paint will be at the discretion of the manufacturer but shall be a product pre-qualified by the specified procedure. (See SS 321.11 for tendering prerequisites).

321.04 Detail Requirements - Paint to this specification shall comply with the following:

a) Consistency: 85 ± 5 Kneb units. Test method ASTM D 562.

b) Drying Time: Maximum 30 minutes at 21°C at 50-60% relative humidity. Test method ASTM D 711.

c) Bleeding: The paint shall have a degree of resistance to bleeding of seven or greater. Test methods ASTM D 969 and D 868.

d) Road Service Life: The paint shall obtain satisfactory ratings for general appearance, durability and night visibility during seven to eight months of service (June to December approximately) under heavy traffic on bituminous pavement in the vicinity of Victoria or Vancouver, British Columbia. Satisfactory ratings are defined as being equal to or better than those obtained by paints currently "Qualified" by the Ministry.

To be "qualified", a product must be acceptable to the Ministry's "New Products Evaluation Standing Committee".

e) Handling Qualities:

i) The degree of settling after five months storage shall be such that the paint can be readily re-mixed to a uniform consistency and there shall be no skinning. The paint shall not have marked thixotropic properties.

ii) The paint shall be capable of being sufficiently atomized to produce a uniformly applied line 100 mm in width with absence of side splatter, overspray, or cobwebbing within the limits imposed by the application equipment used on the Ministry line painting contractor's line striping machines.

iii) The paint shall be capable of being successfully applied to at least 2 km of dash line without the necessity of making adjustments to any machine settings and without showing any evidence of distortion of the spray pattern or appreciable build up of paint in the spray gun tips.

f) Colour:

i) White paint shall comply with US Federal Specification 595b White 17886.

ii) Yellow paint shall conform to the a-b colour box for traffic paint using the L*a*b colour coordinate system.

g) Quality Control: Paint supplied under contract shall be identical with the sample submitted for qualification (See Subsection 321.03). Paint shall be considered identical if it has been manufactured within the following tolerances:

i) Mass per litre: ± 25 g of the value on the Traffic Paint Data Form.

ii) Drying time: Maximum 30 minutes and within ± 5 minutes of the value shown on the Traffic Paint Data Form.

iii) Composition of Paint: Within the tolerances indicated by the manufacturer on the Traffic Paint Data Form.

The Ministry reserves the right to conduct whatever other tests are deemed necessary to identify the paint supplied with the paint submitted for qualification.

321.05 Packaging - Paint required to be supplied in 204.6 ℓ (45 Imperial gallon) drums shall be shipped in heavy duty, leakproof, clean, open head steel drums. Special precautions are necessary to ensure that lids are sufficiently secure to withstand offloading by rolling or dropping from a truck deck.

Drums must be sealed vapour proof.

The drums may be chargeable but must be returnable for credit or cash equal to the charge.

321.06 Delivery - Delivery at 36 000 ℓ (8,000 Imperial gallons) a week shall commence within 3 weeks of date of the award of the contract. This rate shall be maintained until advised in writing by the Ministry that a slower rate is required. In the event that the delivery rate is to be increased after having been decreased or temporarily stopped, the manufacturer shall increase production within one week of notification. The delivery rates and notification times apply to paint released for shipment and the manufacturer shall allow 24 hours for such release to be authorized (See SS 321.07). If a batch is rejected for non-compliance with these Specifications, the resulting deficit in delivery rate shall be made good within one week.

A manufacturer unable to meet this requirement may obtain qualification and may supply paint to the Ministry, provided that the manufacturer states clearly the rate at which the paint can be delivered at the time of applying for

qualification and on any quotation submitted after qualifications has been obtained. If awarded part of the contract this requirement will apply as modified by the lower rate quoted.

321.07 Release for Shipment

- a) The manufacturer shall run quality control tests for each batch of material and shall report the results on the prescribed form.
- b) The manufacturer shall notify the Ministry of times at which each batch is to be filled into drums. Samples shall be taken by the Ministry Representative at that time.
- c) The batch will be released for shipment by the Ministry after sufficient tests have been run to identify the batch with the sample originally qualified and after receipt of the manufacturer's quality control test results. Such release shall not be a bar to subsequent rejection of the material if it is found to have unsatisfactory handling qualities in the field (See SS 321.04 (e)) or if its properties of consistency and drying time fail the requirements within one month of the date of manufacture.

321.08 Labelling - Each container shall be clearly marked with Batch Number, Date of Manufacture, Name of Manufacturer and Manufacturer's Code Number on both drums and lids. These markings shall be affixed so that they will not be affected by weather or handling.

321.09 Rejection - Paint rejected for non-compliance with these specifications shall be replaced with paint that does so comply, at the manufacturer's expense, including handling and transportation charges.

321.10 Non Delivery Penalty - Failure of a manufacturer to deliver paint at the specified rate (See SS 321.06) necessitating the Ministry obtaining a proportion of the order from an alternative supplier will result in cancellation of that proportion of the contract and payment of a penalty based on that proportion. The penalty will be negotiated by the Chairman of the Purchasing Commission at the time of default.

SECTION 407

FOUNDATION EXCAVATION

407.01 Scope – This Section covers foundation excavation for structures including, but not limited to, excavation for abutments, piers, walls, culverts, manholes and bridge end fills, as specified herein, and shall apply generally to all structures other than those where it distinctly states that the prices bid are inclusive of excavation.

407.02 Excavation – All materials shall be removed as necessary for the construction of foundations or other works. Foundation excavations shall not be larger than is reasonably necessary. Excavations and adjacent highways and other facilities shall be protected as necessary by barricades, shoring, dykes and/or cofferdams.

Excavations shall be constructed in compliance with the applicable Workers Compensation Act, Occupational Health and Safety Regulations, BC.

407.03 Description of Material Types – "Solid rock" shall include all material of sufficient hardness to require breaking up by continuous drilling and blasting before removal, and boulders 1.5 cubic metres volume or more. "Other Materials" shall include all other materials which must be excavated.

No distinction shall be made between wet and dry excavation.

407.04 Preparation of Foundations – Care shall be taken not to disturb the bottom of the excavation. If the bottom of the excavation is disturbed in material other than rock, the Contractor shall remove and dispose of all disturbed material and shall replace it with material meeting the material, placement and compaction requirements of SS 201.40 Bridge End Fill. If the bottom of the excavation is disturbed in rock, the Contractor shall remove and dispose of all disturbed material and shall replace it with a concrete sub-footing, as directed by the Ministry Representative.

Where concrete is to be placed on rock, the rock surfaces shall be clean and free from any loose materials.

The bottom of the excavation shall be capable of providing a competent foundation and may require confirmation by the Ministry Representative prior to further works. Where, in the opinion of the Ministry Representative, the bottom of an excavation is not competent, the Ministry Representative may direct the Contractor to excavate deeper. The Ministry Representative may direct replacement of the incompetent material with material meeting the material, placement and compaction requirements of

SS 201.40 Bridge End Fill or with a concrete sub-footing.

Unless underwater concreting is approved by the Ministry, excavations for concrete structures shall be dewatered, if necessary, so that concrete is placed in the dry.

407.05 Backfilling – After the structures are sufficiently built, excavations shall be backfilled to the original ground contours, or as directed by the Ministry Representative.

Drainage course material shall be installed as shown on the Drawings. The gradation of the drainage course materials shall be as follows:

SIEVE SIZE mm	% PASSING BY MASS
40	100
20	0 – 100
10	0

407.06 Measurement and Payment – Payment for foundation excavation will be made at the Unit Price per cubic metre bid for the material types as identified in SS 407.03. Payment shall include, excavation, shoring, barricades, backfilling to the original ground contours with suitable material, compaction of the material, compaction tests and quality control. No payment will be made for removal and replacement of material disturbed by the Contractor below the required depth of excavation. Payment shall cover the supply and placement of gravel drainage courses, filter cloth and drain pipes, and joint waterproofing membranes if shown on the Drawings. Payment shall also cover restoration of roadway gravel and pavement damaged by the Contractor's operations. Where there is an excess of excavated materials or excavated materials are deemed unsuitable by the Ministry Representative, payment shall cover loading, hauling and disposal of such materials.

Excavated materials which the Ministry Representative deems unsuitable for backfill will be replaced with suitable material by the Ministry.

Excavation for footings, box culverts or manholes – no payment will be made for material removed outside vertical planes 600 mm beyond the edges of the structures. Volumes shall be above the bottom of the excavations as shown on the Drawings or directed by the Ministry Representative.

SECTION 407

FOUNDATION EXCAVATION

Excavation for culverts – no payment will be made for material removed beyond a width of 600 mm plus the outside diameter of the culvert.

No allowance shall be made for excavation for catchbasins.

In the case of excavation for bridge end fill, payment will be made for material removed to the neat lines as shown on the Drawings and shall cover loading, hauling and disposal of such material.

Progress payments will be made on the following basis:

<u>Work</u>	Solid Rock	Other Materials
Excavation	80%	60%
Backfilling or Disposal	20%	40%

REVISED SECTION

SECTION 412

CONCRETE REINFORCEMENT

DESCRIPTION

412.01 Scope – This Section describes the supply, fabrication and installation of reinforcing for concrete structures.

The requirements of CAN/CSA-S6-06, “Canadian Highway Bridge Design Code” shall apply unless specified otherwise herein or in the Contract Documents.

For items not covered by CAN/CSA-S6-06, “Canadian Highway Bridge Design Code” or the Contract Documents, CAN/CSA A23.1 shall apply.

References to standards shall be to the current editions at time of tendering.

MATERIALS

412.11 General – All reinforcing bars shall be deformed except for spirals and ties where plain bars may be used.

The type and grade required shall be as specified on the Purchase Order, Work Order, Drawings or Special Provisions.

Wire ties for reinforcing steel, conforming to ASTM A 82/A 82M, shall be minimum 1.6 mm diameter, cold drawn, annealed steel wire.

Two copies of mill certificates giving chemical and physical properties of the reinforcing steel shall be furnished to the Ministry Representative.

The identification of reinforcing bars shall be maintained throughout the fabrication, coating (if required) and shipping processes to the installation on the job.

The Contractor shall, as part of the quality control program, have random samples (selected by the Ministry Representative) of reinforcing steel, both coated and uncoated, tested for bending and tension. Two samples shall be taken of each size and grade of bar used on the project. Testing shall be in accordance with CAN/CSA-G30.18 unless otherwise specified. Testing shall be performed by an approved testing agency.

412.11.01 Uncoated Reinforcing Steel – Concrete reinforcement shall conform to the requirements of the ASTM and CSA Standards shown in Table 412-A, as applicable.

412.11.02 Epoxy-Coated Reinforcing Steel – Epoxy-coated reinforcing steel bars shall conform to the requirements of ASTM A_775M and D_3963M. Application plants shall be certified under the Concrete Reinforcing Steel Institute (CRSI) Voluntary Certification Program for Fusion-Bonded Epoxy-Coating Applicator Plants, and proof of certification shall be submitted to the Ministry Representative. Pre-treatment of the near white blast cleaned surfaces with chromate or equivalent is

TABLE 412-A REQUIREMENTS FOR UNCOATED REINFORCING STEEL

ASTM Test	STANDARD TEST METHOD / PROCEDURE
A 82 A 82M	Standard Specification for Steel Wire, Plain, for Concrete Reinforcement
A 185 A 185M	Standard Specification for Steel Welded Reinforcement
A 496 A 496M	Standard Specification for Steel Wire, Deformed, for Concrete Reinforcement
A 497 A 497M	Standard Specification for Steel Welded Wire Reinforcement, Deformed, for Concrete
CAN/CSA G30.18	Billet Steel Bars for Concrete Reinforcement

mandatory prior to the application of a minimum of 180_μm of cured thickness of protective epoxy-coating by an electrostatic spray method. All epoxy-coated bars shall be clearly labelled with the name of the manufacturer, the primer and the coating system used and the date of production. The method of labelling shall be determined by the applicator plants and test certificates of performance of coated bars shall be submitted to the Ministry Representative.

Further to paragraph 9.2 of ASTM D_3963, the identification marks on all coated reinforcing bars shall be maintained from the point of delivery until they are incorporated into the structure.

The Ministry Representative may require samples of epoxy resin and epoxy patching material for acceptance testing as called for in ASTM A_775M. The Ministry Representative may require tests of coated bars as called for in ASTM A_775M.

412.11.03 Galvanized Reinforcing Steel – Galvanized reinforcing bars shall be used only where shown on the Drawings. Substitution of galvanized reinforcing bars in place of epoxy-coated reinforcing bars will not be permitted. Substitution of epoxy-coated reinforcing bars in place of galvanized reinforcing bars will not be permitted. Hot dipped galvanized reinforcing bars shall conform to the requirements of ASTM A 767M – Class 1 Coating and CAN/CSA G164-M92.

Only Grade W bars shall be galvanized.

All bent bars shall be heat treated for stress relieve prior to galvanizing. Stress relieve shall be at temperature from

SECTION 412

CONCRETE REINFORCEMENT

480C to 560C for 1 hour per 25 mm of bar diameter as per ASTM A-767M

Galvanized reinforcing bars shall not be placed in contact with uncoated reinforcing bars.

412.11.04 Fibre Reinforced Polymer (FRP) – FRP components and FRP reinforcing bar shall conform to CSA Specification S806. FRP reinforcing bars shall be used only where shown on the Drawings.

All FRP products shall comply with Specifications for Product Certification of Fibre Reinforced Polymers (FRPs) as Internal Reinforcement in Concrete Structures developed by ISIS Canada.

412.11.05 Order Lists and Bending Diagrams – All order lists and bending diagrams shall be submitted to the Ministry Representative for review before material is ordered.

The review of order lists and bending diagrams by the Ministry Representative shall not relieve the Contractor or Suppliers, as applicable, of responsibility for the correctness thereof.

CONSTRUCTION

412.31 Bending – Reinforcement bars shall be cut and bent to the shapes shown on the Drawings. Bending shall be sufficiently accurate that the placing tolerances (SS 412.33.01) can be met. All bars shall be bent cold, unless otherwise permitted. Bars partially embedded in concrete shall not be field bent except as shown on the Drawings or specifically permitted.

Field bending of galvanized steel reinforcing and fibre reinforced polymer is not allowed.

412.31.01 Hooks and Bend Dimensions – Where hooks are shown on the Drawings, they shall have the following dimensions, unless shown otherwise:

- 180° bend plus extension of at least 4 bar diameters, but not less than 60 mm.
- 90° bend plus extension of at least 12 bar diameters.
- for stirrups and ties only, either a 90° or a 135° bend plus extension of at least 6 bar diameters at the free end of the bar.
- Minimum inside diameters of bends shall be as shown in Table 412-B. For galvanized and FRP reinforcing bars, the bend diameters shall be the same as required for epoxy coated bars.

Exceptions:

- Minimum inside diameters of bends and 90° and 135° hooks for stirrups and ties shall be 4 bar diameters for uncoated bars and 8 bar diameters for epoxy-coated bars.
- Minimum inside diameters of bends in welded wire fabric, plain or deformed, for stirrups and ties shall not be less than 4 wire diameters for deformed wire larger than 7

mm and two wire diameters for all other wires, except that bends with an inside diameter of less than 8 wire diameters shall be not less than 4 wire diameters from the nearest welded intersection.

Note: Reinforcing bars shall be pre-bent before galvanizing unless otherwise acceptable to the Ministry Representative. Minimum bend diameters if pre-bent and galvanized will be as for epoxy coated bars.

Bars partially embedded in concrete shall not be field bent except as permitted by the Ministry Representative.

412.32 Handling and Storage – Reinforcing bars shall be stored on platforms, skids or other suitable supports clear of the ground and shall be protected as practicable from mechanical injury and surface deterioration caused by exposure to conditions producing rust. When placed in the work, reinforcement shall be free from dirt, loose rust or scale, mortar, paint, grease, oil, or other materials that would reduce bond.

412.32.01 Epoxy-Coated Reinforcing Steel – Epoxy-coated reinforcing bars shall be handled and stored so as to minimize damage to the coating. Equipment for handling the bars shall have protected contact areas. Nylon slings or padded wire rope slings shall be used. Suitable bundling bands shall be used to prevent damage. Bundles of coated bars shall be lifted at multiple pick-up points to prevent bar-to-bar abrasion from sags in the bundles of bars. The bars or bundles shall not be dropped or dragged.

Coated steel reinforcing bars shall be stored off the ground on protective cribbing, and timbers placed between bundles when stacking is necessary. Supports shall be placed sufficiently close to prevent sags in the bundles.

Long term storage of epoxy-coated bars shall be minimized.

If circumstances require storing coated steel reinforcement

TABLE 412-B MINIMUM INSIDE DIAMETERS OF BENDS

BAR SIZE	UNCOATED BARS (mm)			EPOXY COATED BARS (mm)
	300R	400R or 500R	400W or 500W	
10M	60	70	60	80
15M	90	100	90	120
20M	-	120	100	160
25M	-	150	150	200
30M	-	250	200	240
35M	-	300	250	350
45M	-	450	400	450
55M	-	600	550	550

outdoors for more than two months, protective storage measures shall be implemented to protect the material from sunlight, salt spray and weather exposure. Coated steel reinforcing bars stored in corrosive environments will require protection sooner. Coated steel reinforcing bars or bundles shall be covered with opaque polyethylene sheeting or other suitable opaque protective material.

Coated bars shall not be cut or bent on the job without the permission of the Ministry Representative. In any case, the flame-cutting of coated bars will not be permitted.

When placing coated steel reinforcing bars, all wire bar supports, spacers, and tying wire shall be coated with non-conductive material, for example, an epoxy-coated or plastic coated material compatible with concrete.

When immersion-type vibrators are used to consolidate concrete around epoxy-coated steel reinforcing bars, the vibrators shall be equipped with rubber or non-metallic vibrator heads

Any bar with coating damage exceeding 2% of the surface area of the coated steel reinforcing bar in any 300 mm length, the coated bar shall be rejected. When the extent of the damage does not exceed 2% of the surface area in any 300 mm length, all damaged coating shall be repaired with patching material in accordance with ASTM A 775M, Section 12. Patching material shall be applied in strict accordance with the manufacturer's written instructions. Prior to application of the patching material, rust shall be removed from the damaged areas. The patching material shall be allowed to cure before placing concrete over the coated steel reinforcing bars.

The "Guidelines for Jobsite Practices", contained as an Appendix of ASTM A 775M shall be mandatory.

Where on-site inspection or testing by the Ministry Representative does not confirm the coating thickness or integrity, for any shipment of bars, such bars may be rejected, and in any case shall not be placed in the structure until the Ministry Representative is satisfied as to their acceptability.

The Contractor shall make available to the Ministry Representative, for inspection and acceptance, all repairs performed to protective coatings on any reinforcing steel. Repairs of epoxy coatings shall not be performed when the coated bar or ambient air temperature is 5°C or less, or when moisture is present on the bar. Patching material shall not be applied if precipitation is expected within four hours of the procedure. If precipitation does occur within four hours, the Ministry Representative shall determine as to whether the material as applied is acceptable or must be replaced. If the placed coated bars have been exposed to salt spray or road salts, the bars shall be rinsed with fresh water to remove any chloride contamination prior to placing concrete.

412.33 Placing and Fastening – Before any concrete is placed, the placing and securing of reinforcing steel including dowels, within the area of concrete placement shall be complete. Tying in place of all dowels projecting from the area of concrete placement shall be acceptable to the Ministry Representative before any concrete is placed. The reinforcing steel shall be free from dirt, detrimental rust, loose scale, paint, oil or other foreign material.

Reinforcement shall be placed in the positions shown on the Drawings, within the tolerances specified below, adequately supported and secured against displacement. All splices of adjacent bars shall be securely tied together. Tying 100% of the bar intersections is required where the bar spacing centres are 300 mm or greater. Tying of 50% of the bar intersections is required when the bar spacing centres are less than 300 mm.

The locations of the top reinforcing steel in bridge decks shall be checked by running a full deck-width template along the longitudinal screeds. The lower edge of the template shall be set at the nominal cover dimension (see Drawings) below the level of the deck surface. No steel shall touch the template nor be more than 6 mm distant from it.

The location of reinforcing steel near deck joint anchors shall be adjusted so that there will be no interference with the deck joint anchors.

Tack welding of reinforcement for cage assembly or securing of reinforcement will be permitted only with the written acceptance of the Ministry Representative. In no cases shall stirrups be welded to tensile reinforcement.

412.33.01 Tolerances – Tolerances for placing reinforcement shall, unless otherwise specified, be as shown in Table 412-C.

412.33.02 Bar Supports and Spacers – Bar supports and spacers shall be adequate to ensure concrete cover and bar spacings are maintained within the specified tolerances.

Bar supports and spacers shall be sufficient in number and strength to support the reinforcement and prevent displacement by workers or equipment before and during concreting and shall be adequately spaced to ensure that any sagging between supports does not intrude on the specified concrete cover.

Bar supports and spacers shall be of a type and material that will not cause rust spots, blemishes or spalling of concrete surfaces.

Bar supports and spacers shall be precast concrete, plastic, steel wire, stainless steel or steel bar, except that, supports or spacers over 200 mm in height shall be precast concrete or steel bar.

Bright wire and uncoated steel supports and spacers may only be used where they are not in contact with soil surfaces, finished concrete surfaces or epoxy coated

TABLE 412-C TOLERANCES FOR PLACING REINFORCEMENT

Concrete cover to top reinforcing steel in bridge decks	+ 6 mm – 0 mm
Concrete cover to reinforcement, other than top reinforcing steel in bridge decks	± 8 mm
Bar location, except cover, when depth of a flexural member, thickness of a wall or smallest dimension of a column is 200 mm or less	± 8 mm
Bar location, except cover, when depth of a flexural member, thickness of a wall or smallest dimension of a column is larger than 200 mm but less than 600 mm	12 mm
Bar location, except cover, when depth of a flexural member, thickness of a wall or smallest dimension of a column is 600 mm or larger	± 20 mm
Longitudinal location, except cover, of bends and ends of bars	± 50 mm
Longitudinal location, except cover, of bends and ends of bars at discontinuous ends of members	± 20 mm

reinforcement.

Where concrete surfaces are to be exposed to sandblasting, sea water, or de-icing chemicals the bar supports and spacers shall be either stainless steel, hot dipped galvanized steel, epoxy coated reinforcing steel, plastic or precast concrete.

Precast concrete supports shall have a compressive strength and quality not less than that of the concrete in which they are embedded. For finished surfaces, the face of the support in contact with the forms shall not exceed 50 mm in any dimension and shall have a colour and texture to match that of the finished concrete surface.

Bar supports and spacers for approach slabs and formed horizontal slabs such as bridge decks, bridge sidewalks, and top slabs of culverts shall meet the following additional requirements:

- a) Supports or spacers up to 200 mm in height shall be either precast concrete or plastic.
- b) Supports and spacers over 200 mm in height shall be either:
 - i) precast concrete,
 - ii) bent or welded steel bar that has been hot-dipped galvanized after fabrication,
 - iii) stainless steel bar, or
 - iv) epoxy coated reinforcing steel bar

c) Plastic supports or spacers shall have an individual minimum breaking strength of 4.5 kN (1000 lbs) and shall be capable of maintaining strength and dimensional properties for the range of temperatures encountered on site.

d) Maximum spacing between supports, for each mat of bars, shall be 1200 mm, except that the maximum spacing between plastic supports, for each mat of bars, shall be 1000 mm.

e) Each support shall carry the load from not more than one mat of reinforcing steel, except as provided below:

- i) Where a support is used that is specifically designed by the manufacturer to carry two mats at two separate positions, or
- ii) If the top mat of reinforcing steel is more than 200 mm above the slab soffit, then the top mat may be supported by epoxy coated reinforcing steel spreader bars secured between the top and bottom reinforcing mats, provided that, the bottom reinforcing mat is supported on precast concrete chairs which are sufficient in number and adequately spaced to carry the additional weight of the top mat of reinforcing steel.

412.33.03 Concrete Cover – Concrete cover for reinforcing steel shall be as listed in Table 412-D, unless shown otherwise on the Drawings.

TABLE 412-D CONCRETE COVER FOR REINFORCING STEEL

Concrete cast against ground	100 mm
Tops of deck slabs	70 mm
Undersides of deck slabs	40 mm
Other surfaces	60 mm

412.33.04 Spirals – Spirals shall be held in place and to line by vertical spacers.

For spiral rods less than 15M spacing shall be as follows:

- two spacers per loop for spirals less than 500 mm in diameter.
- three spacers per loop for spirals 500 mm to 800 mm in diameter.
- four spacers per loop for spirals over 800 mm in diameter.

For spiral rods 15M and larger spacing shall be as follows:

- three spacers per loop for spirals up to 600 mm in diameter.
- four spacers per loop for spirals over 600 mm in diameter.

SECTION 412

CONCRETE REINFORCEMENT

If vertical reinforcements are to serve as spacers, spirals shall be securely tied to vertical reinforcement at the spacing required for spacers.

412.34 Splicing of Bars – Special requirements for splicing, such as particular locations for splices, use of overlength bars or special lap lengths, shall be as shown on the Drawings.

Splices in bars larger than 35M shall be mechanical coupler splices or welded. The detail of such splices shall be subject to acceptance by the Ministry Representative.

412.34.01 Lapped Splices

- a) Horizontal bars shall not be spliced unless greater than standard mill lengths – 12 m for 10M bars and 18 m for larger bars – would otherwise be required.
- b) Splices to be staggered so that no more than one third of the reinforcing steel in a member shall be spliced in any transverse section that is within the required lap length.
- c) If not shown on the Drawings, the length of lapped splices shall be in accordance with CAN/CSA-S6-06, “Canadian Highway Bridge Design Code”, Clause 8.15.9.1.
- d) Adjacent reinforcing bars shall not be spliced at the same locations unless shown on the Drawings or authorized by the Ministry Representative.
- e) Column spirals shall be lapped 48 rod diameters at splices.

412.34.02 Welded Splices – Welded splices shall be used only if detailed on the Drawings or acceptable to the Ministry Representative in writing. Welding shall conform to the requirements of CSA Standard W186, Welding of Reinforcing Bars in Reinforced Concrete Construction and shall be performed by a company certified by the Canadian Welding Bureau to the requirements of CSA Standard W186. Welded splices shall not be used on epoxy coated bars.

412.34.03 Mechanical Coupler Splices – Mechanical couplers shall be used for splices only if pre-approved or detailed on the Drawings or authorized in writing by the Ministry Representative. Such couplers shall develop in tension or compression, as required, at least 120% of the specific yield strength of the bars, but not less than 110% of the mean yield strength, representative of the bars to be used, in the test of the mechanical connection.

Wedge couplers shall not be used in bars greater than 15 mm diameter.

When mechanical couplers are used the Contractor shall ensure that the minimum concrete cover as specified is maintained.

The total slip of the reinforcing bars within the splice sleeve of the connector after loading in tension to $0.5f_y$ and relaxing it to $0.05f_y$ shall not exceed the following measured displacements between gauge points straddling the splice sleeve:

- Up to and including 45M bars 0.25 mm
- 55M bars 0.75 mm

MEASUREMENT

412.81 General – When required, reinforcing steel will be measured by KILOGRAMS for the total mass in each part of the structure(s) as computed using Table 412-E.

The mass of clips, separators, tie wires, chairs and other fastening devices, and epoxy or other coating shall not be added into the calculations of mass of reinforcing steel.

TABLE 412-E NOMINAL LINEAR MASS FOR REINFORCING STEEL

BAR DESIGNATION	MASS (kg)
10M	0.785
15M	1.570
20M	2.355
25M	3.925
30M	5.495
35M	7.850
45M	11.775
55M	19.625

PAYMENT

412.91 General – Payment for REINFORCING STEEL will be made at the Contract Lump Sum Prices for reinforcing steel in each part of the structure(s), for the supply, cutting, bending, coating (if required), shipping, placing and securing of reinforcing steel. Payment shall also include all costs associated with quality control.

Payment for increases or reductions in quantities of uncoated and coated reinforcing steel ordered by the Ministry Representative will be made at the following Unit Prices per kilogram.

- Uncoated reinforcing steel \$3.00
- Epoxy-coated reinforcing steel \$4.00
- Galvanized reinforcing steel \$5.00

THIS PAGE IS LEFT INTENTIONALLY BLANK

SECTION 413

BRIDGE DECKS AND CONCRETE OVERLAYS

DESCRIPTION

413.01 General – This Section describes requirements for the construction of Bridge Decks, and for the construction of Concrete Overlays on previously constructed (old) bridge decks and on newly constructed (new) bridge decks. The requirements of SS 211 shall apply except as otherwise specified in this Section. Unless otherwise specified in this Section, bridge deck concrete shall include diaphragms, deck slabs, bridge parapets and medians, bridge sidewalks, approach slabs and overlay concrete.

413.31 Bridge Decks

413.31.01 General – Deck slab construction shall be full-width and continuous between the joints shown on the Drawings, and shall be placed in the sequence as shown on the Drawings. Any variation from this requirement shall be subject to acceptance by the Ministry Representative.

413.31.01.01 Camber Survey – Prior to commencing deck construction and subsequent to the completion of the erection of girders, with the girders in a thermally neutral condition and with no dead load other than the dead load of the girders and necessary fall protection, the Contractor shall profile all the girders. Camber elevations are to be taken at 2000 mm centres maximum (or as indicated on the Drawings or Special Provisions), centrelines of all bearings and ends of girders. The camber elevation locations are to be laid out to an accuracy of 25 mm horizontally and camber elevations taken to the nearest 1 mm vertically. Within 14 days of the Contractor supplying the camber elevations to the Ministry Representative, the Contractor will receive haunch heights for setting the deck slab soffit, (for suspended slab type structures only) and the design finished grade elevations for the deck, complete with anticipated dead load deflections at 1000 mm stations along the centreline of roadway, to be used by the Contractor in establishing the required screed rail settings.

In the event that actual girder camber values vary significantly from the design values, the Contractor will be required to modify the original design finished grade as directed by the Ministry Representative.

413.31.01.02 Method, Equipment & Personnel – The Contractor shall submit to the Ministry Representative for review, four weeks prior to the scheduled start of deck slab concrete placement, a complete description of the method, equipment and personnel, including previous deck placement experience of the personnel to be employed. This shall include the equipment for mixing, transporting, placing, vibrating and curing the concrete and shall also include details of the finishing equipment and support rails. All equipment shall be subject to inspection and acceptance by the Ministry Representative. Equipment

may be rejected during operation if it is unsatisfactory.

Two weeks prior to the scheduled start of deck slab concrete placement, the Contractor shall meet with the concrete supplier and the Ministry Representative to review deck concrete operations with respect to concrete mix design and performance, concrete delivery, placing, finishing and curing equipment and methods.

413.31.01.03 Haunch Setting, Screed Rails & Reinforcing Cover – The Contractor shall set the deck slab soffit formwork to within 2 mm of the haunch dimension as determined in accordance with SS 413.31.01.01.

After installation of the deck slab reinforcing, the Contractor shall set the screed rails for the deck finishing machine. Screed rails shall be installed to an accuracy of ± 2 mm and have a maximum deflection between supports of 1 mm. Allowance for dead load deflection of the structure shall be made in the screed rail setting as well as any anticipated deflection due to the loading of any formwork that may be supporting the screed rail system. The screed rails shall be adequately supported outside the area to be concreted and shall be completely installed before concrete is placed, unless otherwise accepted by the Ministry Representative.

Prior to the placement of deck slab concrete and subsequent to the installation of deck slab reinforcing and screed rails, the locations of the top reinforcing steel in bridge decks shall be checked by running a full deck-width template along the longitudinal screeds. The lower edge of the template shall be set at the nominal cover dimension (as specified or noted in the Drawings) plus any anticipated deflection of the screed rail support system below the level of the deck surface. No steel shall touch the template nor be more than 6 mm distant from it. Any discrepancies outside of these limits shall be corrected by the Contractor to the satisfaction of the Ministry Representative.

413.31.02 Concrete Placement

413.31.02.01 Concrete Temperature at Placement – Concrete designed for bridge decks including any bridge deck concrete containing silica fume shall not have a temperature in excess of 17°C at time of placement. Concrete used in elements having a minimum section thickness greater than 1000 mm shall have temperature controls as per CSA A23.1 Clause 5.2.4.4. Methods used for maintaining temperature controls shall not diminish the quality of the concrete, and shall not exceed the specified W/C_m ratio.

When the atmospheric temperature is 15°C or higher, SS 211.18 – Hot Weather Concreting, shall apply except

SECTION 413

as modified herein.

Concrete for bridge decks and overlays shall not have a temperature greater than 17°C when placed. Prior to the placement of bridge deck and overlay concrete, when the ambient air temperature is at or above 15°C, or when there is a probability of its rising to 20°C or above during the placement period (as forecast by the nearest official meteorological office), the Contractor shall submit to the Ministry Representative for acceptance, the proposed placing operations complying with the requirements for hot weather concreting.

When the ambient air temperature is at or above 15°C, or when there is a probability of its rising to 20°C or above during the placement period (as forecast by the nearest official meteorological office), bridge decks and overlays shall be cast when daily air temperatures are forecast to be a minimum (normally between 12:00 midnight and 9:00 AM).

413.31.02.02 Time of Placement – All bridge deck and overlay concrete shall be fully discharged and placed in its final location within 45 minutes after the water and cement have been combined. Under conditions contributing to rapid stiffening of concrete, the Ministry Representative may require a time of less than stated above.

Time of placement extensions will be considered on a case by case basis and may require the use of Hydration Stabilizing Admixtures (HSA's) conforming to the requirements of ASTM C494 Type B, Retarding or Type D, Water-Reducing and Retarding Admixtures. If accepted by the Ministry Representative, guidelines for the use of HSA's shall be as follows:

HSA modified concrete for bridge decks shall be fully discharged and placed within 90 minutes after water and cement have been combined.

When HSA's are used, these time extensions are subject to preconstruction trials being conducted by the Contractor, to establish the appropriate HSA dosage to provide suitable extended slump life of concrete, without increasing the water/cementitious ratio of the concrete above that which would be required if HSA's were not used. The use of HSA's shall in no instance modify the maximum concrete temperature required at time of placement. A one time only addition of HSA will be allowed. This will be during initial batching of the concrete or immediately at completion of batching as recommended by the admixture manufacturer. Addition of HSA at any other time will be cause for rejection of the concrete.

413.31.02.03 Concrete Placement-Diaphragms – Unless otherwise specified, diaphragms shall be placed either:

a) about two hours before the deck concrete. In this case, diaphragm concrete shall have a slump less than 40

BRIDGE DECKS AND CONCRETE OVERLAYS

mm and shall be retarded so that it sets at the same time as the deck concrete, or

b) a sufficient length of time ahead of the deck concrete, so that the diaphragm concrete attains a compressive strength of 15 MPa before the deck slab is cast.

Sequence for the placing of concrete for diaphragms at ends of girders on continuous and integral type spans shall be as shown on Drawings.

413.31.02.04 Concrete Placement-Deck Slab – The top surfaces of concrete stringers shall be prepared in accordance with SS 211.12.03 and the surfaces shall be in a saturated surface dry condition immediately before the deck is cast.

Concrete shall be placed at a rate of not less than 6 m/hr. The concrete front and finishing operation shall be kept parallel to the substructure. Placing shall be started at such time as to permit finishing during daylight hours, except if ambient temperatures are as outlined in SS 413.31.02.01, then adequate lighting is to be provided in accordance with Workers Compensation Act, Occupational Health and Safety Regulation, BC, to allow for concrete operations under reduced light conditions.

In the event of unexpected rain, concrete placing shall cease and the surface shall be protected immediately. Surface concrete which has been rained on shall immediately be removed to the top of reinforcing steel.

413.31.02.05 Finishing – The deck surface shall be finished by a drum-type deck finisher on support rails. Two work bridges shall be provided. No inserts will be permitted in the finished roadway surface.

The surface behind the finisher shall be floated transversely to eliminate ridges and open texture. Areas which cannot be machine-finished shall be hand screeded and floated to conform to the machine-finished deck.

Prior to final surface texturing, the deck surfaces shall be repeatedly checked for accuracy of deck slab thickness and alignment. The Contractor shall measure and record the deck slab thickness at a frequency of at least one measurement per interior bay and overhang bay, at a maximum of 3000 mm centers longitudinally. Adjustments as acceptable to the Ministry Representative shall be made to the deck finishing machine to maintain the minimum deck slab thickness and the required concrete cover on the deck reinforcing. The deck slab thickness readings shall be supplied to the Ministry Representative at the conclusion of each placement section.

Bridge deck slab final surface texturing shall be by tining. The tining shall create transverse grooves 3 mm wide by 1.5 mm to 3 mm deep at 20 mm centre to centre spacing.

413.31.03 Repairs – Areas of the deck not meeting the required accuracy of alignment as given in SS 211.16 Table 211-M, shall be corrected as follows:

SECTION 413

a) where the required alignment can be obtained with a maximum cut of 6 mm, the bumps shall be cut with a bump cutter which will provide an acceptable longitudinal grooved texture;

b) where the required alignment cannot be obtained with a maximum cut of 6 mm, the concrete shall be broken out with vertical edges to a minimum depth of 40 mm and shall be replaced with new concrete of the required quality.

Any physical damage to the deck surface shall be cut out and replaced. Any areas of open texture or plucked aggregates shall be repaired to the satisfaction of the Ministry Representative.

413.31.04 Interim Strength Requirements – Deck concrete shall attain a strength of 15 MPa before parapets are placed and 25 MPa before heavy loads, such as concrete trucks are allowed on the bridge.

413.31.05 Curing

413.31.05.01 General – Freshly deposited concrete shall be protected from freezing, abnormally high temperatures or temperature differentials, premature drying, excessive moisture, moisture loss, heavy shocks, excessive vibrations and high stresses, for the period of time necessary to develop the required concrete properties.

The Contractor shall submit a detailed plan for curing deck and overlay concrete. The plan shall contain details such as water source, the distribution system, the collection and run-off control system, person(s) responsible for quality control, and staff to maintain the system. The curing system shall be capable of maintaining a free film of water on the areas of concrete requiring curing, for a minimum of 8 unattended hours and this capability shall be demonstrated prior to concrete placement. It shall be the responsibility of the Contractor to ensure that the system of curing and protection is properly planned, constructed and maintained throughout the entire curing period.

Burlap shall be pre-soaked by immersing it in water for a period of at least 24 hours immediately prior to placing. A layer of burlap shall be applied to the surface of the concrete. Strips must overlap 150 mm and must be held in place without marring the surface of the concrete.

The burlap shall be applied immediately after finishing of the concrete surface within 2 to 4 meters of the final surface texturing operation (no more than 20 minutes) and shall be maintained in a saturated condition in a manner which does not damage the finished concrete surface. The burlap shall be maintained in a continuously wet condition throughout the curing period and a continuous film of free water on the surfaces of the areas noted herein shall be maintained by means of soaker hoses, sprinklers, etc.

Concrete for diaphragms, monolithic decks, concrete overlays, approach slabs, parapets, and sidewalks shall be cured for a minimum of seven consecutive uninterrupted

BRIDGE DECKS AND CONCRETE OVERLAYS

twenty-four hour periods at a minimum temperature of 10°C and for the time necessary to attain 80% of the specified compressive strength of the concrete. The compressive strength tests for verifying completion of the curing period shall be determined using field cured test cylinders cured in accordance with Clause 7.3.4 of CSA A23.2-3C. The curing period will begin following the completed placement of the concrete in the section cast.

The temperature of the concrete being cured must be monitored to ensure maximum and minimum temperature requirements in accordance with SS 211.15.02 are met.

Regardless of ambient temperature, moist curing with burlap and water must be provided at all times. During cold weather, burlap must be prevented from freezing.

At completion of the curing period, the curing shall be discontinued in a manner so as not to subject the concrete to undue stresses due to rapid moisture loss in the concrete.

When the air temperature is at or below 5°C or when there is a probability of it falling below 5°C within the next 5 days after the curing period, then the following shall apply:

- At completion of the curing period, the addition of free water is to be discontinued and followed by an additional 5 consecutive uninterrupted twenty-four hour periods of drying with the concrete temperature maintained at a minimum temperature of 5°C.

413.31.05.02 Additional Curing Requirements for Concrete Containing Silica Fume or Fly Ash, With or Without Fibres – A fog mist shall be applied continuously from the time of screeding until the concrete is covered with burlap, in such a way as to maintain high relative humidity above the concrete and prevent drying of the concrete surface. Water must not be allowed to drip, flow, or puddle on the concrete surface during fog misting, when placing the burlap, or at any time before the concrete has achieved final set.

Fogging equipment will consist of pressure washers (minimum output pressure of 28 MPa (4000 psi)) with suitable tips for producing a fine water mist or fog. A minimum of two pressure washers shall be used for this process and the adequacy of the range and coverage shall be demonstrated prior to placing any concrete.

When the air temperature is at or below 5°C or when there is a probability of it falling below 5°C within the next 10 days after the curing period, then the following shall apply:

- At completion of the curing period, the addition of free water is to be discontinued and followed by additional 10 consecutive uninterrupted twenty-four hour periods of drying with the concrete temperature maintained at a minimum temperature of 10°C.

SECTION 413

Modifications to the curing process may be required if it is anticipated that the deck may be subjected to the application of de-icing chemicals within the first month after the curing period.

413.31.06 Payment – for bridge deck FORMWORK and CONCRETE will be made as outlined in SS 211.21.01 and SS 211.21.02 respectively and payment for bridge deck REINFORCING STEEL will be made as outlined in SS 412.91 unless otherwise provided for in SS 413.

CONCRETE OVERLAYS

413.32.01 General – This Section describes requirements for repair and resurfacing of existing bridge decks (old) and newly constructed bridge decks (new) with a concrete overlay, describing the construction practices, materials and equipment required to place acceptable concrete overlay. This work is usually carried out on one half of the deck at a time, while traffic is maintained on the other half. The requirements of SS 413.31 shall apply except as otherwise specified in this Section.

413.32.02 Gradeline – The Contractor shall survey and reference profiles of the existing bridge deck and approaches prior to scarification as follows:

- Longitudinally the profiles shall be taken at 2 to 3 metre stations for the entire length of the structure, including 21 meters on each end, with additional shots taken at the back of ballast walls and all existing or proposed new joint locations.
- Transversely the number of profiles required will be determined by:
 - A maximum spacing between elevation points of 3 m.
 - Profiles are required 500 mm from each curb or parapet face.
 - Profiles are required 300 mm (inside area to be concreted) from longitudinal overlay construction joint lines requiring adjustable screed rails. In general longitudinal overlay construction joints shall be located at the center of a lane or between lanes. The final location of the longitudinal construction joints is subject to the acceptance of the Ministry Representative.
 - A Profile is required at hinge point of crown.
- Elevation points are to be laid out in cross section ninety degrees to centerline of roadway on straight structures and radial to centerline of roadway on curved or spiraled structures.
- Profile elevation points shall be laid out to an accuracy of ± 20 mm horizontally and elevations taken to an accuracy of ± 3 mm vertically and be referenced such that they can be re-established within ± 25 mm from their original location.

BRIDGE DECKS AND CONCRETE OVERLAYS

The Contractor shall provide the Ministry Representative with the gradeline profiles plotted at a scale of 1:10 vertical and 1:50 horizontal and a spreadsheet showing actual original elevations for all points surveyed.

In the case of old decks, subsequent to scarifying and cleaning of the deck surface, the Contractor shall re-establish the original elevation points, take new elevations for the points to the nearest millimeter and submit these elevations along with plotted profiles to the Ministry Representative.

The Ministry will provide the Contractor with design finished grade profiles and elevations for the survey points as originally laid out by the Contractor. These profiles and elevations shall be used by the Contractor to set the screed rails for the deck finishing machine, checking of overlay thickness during the dry run of the deck machine and for calculating the volume of overlay concrete required.

The Contractor is responsible for properly setting the screed rails to match the design gradeline provided by the Ministry Representative. Depressions creating ponded water, or localized high spots in the concrete surface, resulting from deficient finishing procedures shall be repaired at the Contractor's expense.

At completion of the deck overlay the Contractor shall re-establish the original elevation points and take as built elevations for the points to the nearest millimetre and submit these elevations along with plotted profiles to the Ministry Representative.

No specific payment shall be made for this work as all costs associated with the production of the gradelines and profiles are deemed incidental.

413.32.03 Removal of Existing Concrete Deck Surface

The existing concrete surface shall be removed by use of scarification (roto-milling), hydro-demolition or alternate methods acceptable to the Ministry Representative, over the full length and width of the bridge deck. If methods other than scarification are proposed by the Contractor, the Contractor shall submit all required details of the proposed work to the Ministry Representative and shall obtain the acceptance of the Ministry Representative at least two weeks prior to starting the work. Alternate methods shall meet the requirements specified for scarification.

413.32.03.01 Scarification – If scarified, equipment shall be capable of concrete removal to an accuracy of ± 5 mm. The scarifying equipment shall produce a surface that does not exceed 10 mm in amplitude for roughness. The maximum cut will be to within 10 mm of the reinforcing steel. Depth of scarification will be specified by the Ministry.

The Contractor shall monitor the total depth of concrete cover to the top mat of reinforcing steel using a pachometer or alternate methods acceptable to the Ministry Representative. Readings shall be taken at

SECTION 413

regular intervals ahead of the scarification. The Contractor shall adjust the rate and depth of concrete removal to ensure that the reinforcing steel is not damaged and the desired scarified profile is achieved. All reinforcing steel damaged by the Contractor's operations will be replaced at the Contractor's expense. Care must be taken not to damage the existing deck drains. The Contractor will be required to repair or replace any damaged drains at the Contractor's expense. Drains are to be plugged to insure containment of debris.

All areas inaccessible to the scarification equipment shall be prepared by hydro-demolition, grinders or by jackhammers with weight limited to a maximum 18 kg. Preparation shall minimize damage to the sound substrate concrete. Larger jackhammers may be used if accepted by the Ministry Representative and if performance acceptable to the Ministry Representative can be demonstrated.

In the case of previously overlaid decks, concrete shall be removed to below the old bond line. Where the bond line is within 10 mm of the reinforcing steel, the remaining concrete and the old bonding material shall be removed by hydro-demolition or pneumatic tools.

Upon completion of scarification of the deck, prior to opening the scarified deck lane to traffic and at the direction of the Ministry Representative, the Contractor shall place temporary asphalt tapers (minimum 40:1) using asphalt patch material (cold mix) with tar paper underneath at all deck joints and bridge ends as required to maintain adequate traffic movement. The asphalt tapers shall be maintained until traffic is no longer using that lane or the final paving is complete. The temporary tapers shall be in accordance with SS 502.

413.32.03.02 Payment – Payment for removal of the existing concrete deck surface and asphalt roadway approaches will be made at the Lump Sum price bid. Payment for removal shall include all work for the removal of the concrete and asphalt roadway approaches including but not limited to sweeping, washing and /or blowing of debris, power hand tool removal of all concrete inaccessible to the scarification process, containment and the removal and disposal of all debris from the site. Payment shall also include all labour, material and equipment for the supply, installation and maintenance of temporary let downs, and disposal of all asphalt material from the site.

413.32.04 Removal of Concrete for Partial and Full Depth Repairs

The Contractor, in the presence of the Ministry Representative, shall carry out a detailed visual inspection of the deck surface for patch concrete. A chain drag method shall be used to examine the entire deck surface for evidence of additional delaminated and deteriorated concrete. These areas of unsound concrete and patch concrete shall be removed to sound concrete or removed

BRIDGE DECKS AND CONCRETE OVERLAYS

full depth when considered necessary by the Ministry Representative.

Removal and repair of a specific area will not be completed until the Contractor and the Ministry Representative have inspected the affected areas requiring repair, and have agreed on the extent of repair required.

The Contractor shall supply the necessary labour and supplies to mark out the repair areas.

Partial and full depth concrete deck repairs shall proceed as follows:

- The Contractor shall keep repair boundaries square or rectangular and avoid abrupt changes in width of a given repair area. The edge of the repair area shall be maintained vertical. No debris shall be permitted to fall from the bridge. Saw cut the perimeter of the repair areas to a minimum depth of 25 mm to prevent feather edges. Do not cut the existing reinforcing steel.

- Remove deteriorated, delaminated and patch concrete to sound concrete. Maximum jackhammer weight shall be 18 kg. Care shall be taken to avoid damage to the reinforcement and remaining concrete. Jackhammers are to be operated at angles less than 45° as measured from the surface of the deck to the hand tool. The Contractor shall use wedge type chisel bits. Moyles and round point chisels are not permitted. Adhering concrete shall be removed from the reinforcement using hammers not larger than 7 kg.

- Remove all concrete to allow a 25 mm space around all exposed reinforcing bar within partial depth repairs. Expose all corroded reinforcement at edges of partial and full depth repair area

- Full depth repairs will only apply when the soffit concrete is removed. For full depth repair areas, the Contractor shall install all necessary formwork prior to cleaning of reinforcing and concrete surfaces. The finished soffit repair concrete shall be flush with the surrounding soffit concrete. Areas for full depth repair exceeding 1 m² shall be patched prior to placement of the overlay. Before placement of the concrete patch, the surface of the adjoining concrete should be saturated with water for 30 minutes minimum and coated with a bonding agent immediately ahead of the fresh concrete.

- Mildly corroded reinforcement shall be blast cleaned to commercial blast finish SSPC-SP6. Severely corroded and damaged reinforcement shall be replaced. Mechanical couplers acceptable to the Ministry Representative or laps meeting the CSA S6-06 Code requirements shall be used to attach new bars to the existing bars. Mechanical couplers shall develop at least 125% of the specified yield strength of the bar.

- Prior to the placement of the partial and full depth repair area infill concrete the surfaces of the sub deck within the repair area shall be abrasive blast (minimum

SECTION 413

35 MPa/5000 psi) or high-pressure water blast (minimum 35 MPa/5000 psi) cleaned to remove all bruised and fractured concrete and foreign materials such as dirt, dust, laitance, sand, grease, oil, concrete slurry etc. to the satisfaction of the Ministry Representative.

- The Contractor shall collect and remove all dirt, dust, and blasting sand from the repair areas of the sub deck, by vacuum or similar method, and dispose of the materials off the bridge site. Disposal shall be in accordance with all applicable environmental regulations.

Payment for removal of Concrete for Partial Depth Concrete Repair of the sub deck will be made at the Unit Price per square metre bid. Payment shall be for all labour, materials and equipment to break out the concrete, including; inspections, sounding, cleaning of mildly corroded reinforcing, abrasive blast cleaning of the existing concrete surfaces within the repair areas, saw cutting, and containment and disposal of all debris.

Payment for Removal of Concrete for Full Depth Concrete Repair of the sub deck will be made at the Unit Price per square metre bid. Payment shall be for all labour, materials and equipment to break out the concrete, including inspections, sounding, cleaning of mildly corroded reinforcing, abrasive blast cleaning of the existing concrete surfaces within the repair areas, saw cutting, and containment and disposal of all debris. Payment shall also include the supply, installation and removal of all required formwork.

413.32.05 Reinforcing Steel

Reinforcing steel shall be supplied and installed in accordance with SS 412. Welding of reinforcing bars shall not be permitted.

Severely corroded reinforcing steel in the existing deck, more than 25% section loss as determined by the Ministry Representative, shall be removed and replacement bars spliced to the existing reinforcement using mechanical couplers acceptable to the Ministry or lapped splices. Mechanical couplers and lap length shall be in accordance with CAN/CSA S6-06.

Reinforcing steel damaged by the Contractor's operations shall be replaced at the Contractor's expense.

Payment for replacement of severely corroded reinforcing steel will be made at the Unit Price per kilogram shown for increases and reductions in SS 412.91 and will be paid out of the Provisional Sum Item for Site Modifications. Payment shall be for quality control, supply, cutting, bending, shipping, placing and securing of reinforcing steel.

Payment for mechanical couplers will be made on a Force Account Basis under the Provisional Sum Item for Site Modifications.

BRIDGE DECKS AND CONCRETE OVERLAYS

413.32.06 Removal and Replacement of Existing Deck Joints

413.32.06.01 Expansion joint system – The Contractor is responsible for demolition and removal of existing concrete and expansion joints.

The steel portions of the replacement deck joint shall be supplied and fabricated in accordance with SS 422.

The steel portions of the deck joint shall be galvanized and the joint armoring shall be installed 5 mm below the finished concrete nosing surface. Galvanized surfaces damaged by welding shall be touched up with two coats of an approved zinc rich coating.

Each joint seal shall be supplied in a single length, without splices. Before the joint seal is installed, the joint shall be thoroughly cleaned with a wire brush and all moisture removed from the joint. The seal shall be installed in accordance with the Manufacturer's recommendations.

Payment for deck joints will be made at the Price bid for each joint. Payment shall be for all Work as shown on the Drawings and Special Provisions. Payment shall include but not be limited to demolition and removal of the existing deck and curb concrete, removal of the existing joints seal, preparation of shop drawings; the supply, fabrication, galvanizing, and installation of the joint armoring, anchors, forming, reinforcing and supply and installation of joint seal. Payment shall also include the removal of the joint curb seal section and replacement with a joint sealant within the curbs section.

413.32.06.02 Preparation of Filled Joints – The Contractor shall cut a transverse line, directly above the filled joint location, during casting of the deck overlay concrete using an edge cutter attached to a bull float. The line shall be neat and straight.

The Contractor shall further saw cut the filled joint along the transverse line within 48 hours of casting the deck. The saw cut will be achieved using a 4mm wide diamond blade to a depth of 30 mm below the top of the deck.

The Contractor shall fill the saw-cut with Sikaflex 1C SL, a one-component, self-leveling, polyurethane sealant or an alternate permanent filler, impervious to water and resistant to ultra violet radiation, acceptable to the Ministry Representative. Sealants shall be installed in accordance with the manufacturers' recommendations. The saw cut shall be clean and dry before placing the sealer.

Payment for preparation of filled joints will be made at the price bid for each joint. Payment shall be for all labour, materials and equipment required to produce the filled joints

413.32.07 Preparation of the Sub Deck

The Contractor shall high pressure (minimum 110 MPa/15000 psi @ 68 liters/minute using a rotating head) water blast the surface of the entire concrete

SECTION 413

subdeck including both parapet or curb faces 50 mm up from original deck elevation and abutment ballast walls, no earlier than 2 days before placing the overlay concrete.

The water blasting equipment shall effectively remove laitance, loose materials, bruised concrete, dust, slurry, oil, or other contaminants (as applicable) that are detrimental to the concrete overlay bond and shall leave behind a sound concrete surface, thoroughly cleaned and roughened to partially expose the coarse aggregate. The Contractor shall provide full containment and disposal of all debris, contaminants, etc., and shall comply with all applicable environmental and Workers Compensation Act, Occupational Health and Safety Regulation BC, requirements. The Contractor shall provide adequate guards to contain over spray and flying debris during the scarification, water blasting, deck washing and chipping process. The Contractor shall take all means necessary to reduce and contain the amount of dust produced throughout the entire project.

For the period between water blasting and placement of overlay concrete the sub-deck shall be protected from contaminants.

Water blasting equipment shall always travel downhill, keeping all waste material ahead of the equipment and preventing the waste material from rehydrating on the previously cleaned surface.

Payment for high pressure water blasting the entire deck surface, including both parapet faces and abutment ballast walls, to clean and roughen the sound concrete surface, will be made at the Lump Sum price bid.

Payment shall be for all labour, materials and equipment required to produce the specified surface roughness. Payment shall also be for the containment and treatment of the contaminated water and the removal and disposal of any debris from the site.

413.32.08 Concrete Overlay Placement

All concrete works will be governed by the requirements of SS 211 "Portland Cement Concrete", SS 933 "Admixtures for Portland Cement Concrete" and SS 413.31 except as otherwise specified in this Section.

The Contractor shall be responsible for the design of all concrete mixes. The Contractor shall be responsible for quality control of each component of the concreting operation, including aggregate and component quality, batching, mixing, transporting, placing, consolidating, finishing, curing and testing.

The Contractor shall submit a detailed plan of equipment and manpower to be used for placement and curing of the concrete overlay a minimum of 14 days prior to the scheduled placement dates for the acceptance of the Ministry Representative. The plan shall also contain details such as: water source, the distribution system, the collection and run-off control system, person(s)

BRIDGE DECKS AND CONCRETE OVERLAYS

responsible for quality control, and staff to maintain the system

The Contractor will undertake a test placement of the proposed deck mix design as indicated by the requirements of SS 211.03.05.

Payment for placement of the concrete overlay, partial and full depth repairs will be made at the Unit Price per cubic meter bid. Payment shall be for all labour, materials and equipment for the final preparation and cleaning of the existing prepared concrete sub deck, supply and application of the cementitious bonding agent and the epoxy bonding agent, the supply of cement, silica fume, superplasticizer, all other constituent concrete materials and the supply and placing and curing of the concrete and containment and disposal of all debris.

413.32.08.01 Materials & Equipment – Acceptable types of overlay are High Density concrete and Silica fume modified concrete. For High Density concrete overlays, acceptable finishing machines are Bidwell model OF400, Bidwell model OF500 or alternate (low slump pan-type overlay finishers), acceptable to the Ministry Representative. Concrete shall be produced on site using volumetric concrete mobile mixers. All equipment shall be provided in good working condition.

For structures over 50 m long and structures over 20 m long with a grade greater than 3%, two finishing machines shall be used in tandem. The speed of the trailing machine shall be such that its motion is continuous. Any open texture remaining after two finishing machine passes shall be repaired by hand.

For Silica fume modified concrete overlays, acceptable finishing machines are Bidwell model 4800, Gomaco model CA450 or alternate acceptable to the Ministry Representative. Concrete shall be produced by either a qualified concrete batch plant or at the bridge site using pre-bagged concrete mix and mixer trucks. All equipment shall be provided in good working condition.

Finishing machines shall be capable of forward and reverse motion under positive control and with provision for raising screeds to clear previously screeded surfaces while traveling in reverse.

The Contractor shall provide steel rail mounted mechanical deck concrete finishing equipment of adequate size and design to permit the complete placement and finishing of a single lane section from abutment to abutment with the prescribed surface finish, without forming any cold joints.

The Contractor is responsible for properly setting the screed rails to ensure longitudinal and transverse drainage from the deck without ponded areas or "bird baths".

Sufficient screed guide rails will be set out for the full length of the anticipated section to be cast plus 6 m length at each end for run in and run out of the deck machine,

SECTION 413

adjusted for height and accepted by the Ministry Representative prior to the pour as follows:

- i) Screed guide rails, upon which the finished machine will be placed outside the area to be concreted, will be horizontally and vertically stable. Rails shall be installed with fully adjustable supports at 350 mm maximum spacing
- ii) The finishing machine and guide rails will be adjusted so that the height of the screed above the existing subdeck at each point meets the Ministry Representative's requirements. To confirm the adjustment of the machine and guide rails, the screed will be "dry-run" and clearance measurements taken at 3 m intervals and provided to the Ministry Representative for acceptance. The minimum overlay thickness shall be 50 mm. Resetting of the machine and/or guide rails will be done as necessary to obtain an acceptable "dry-run". Adjustments to the machine or the rails will not be permitted after an acceptable "dry-run" is complete.

Work bridges shall be provided to facilitate bull floating, edge finishing with hand tools, correction of defects in machine finished concrete and tining and fog curing.

Rigid forms made of wood or steel shall be installed at longitudinal bulkheads in a manner that will maintain the desired shape during concrete placement, consolidation and finishing. The longitudinal bulkhead will be installed at the centerline or lane lines of the bridge deck. The top of the longitudinal bulkhead will be set at the finished deck elevation. Any honey combing or poorly consolidated concrete after stripping the longitudinal bulkhead will be cut back into the new overlay a minimum of 150 mm.

The overlay shall be placed in strips with longitudinal joints near lane markings. Each strip shall be placed continuously between joints; adjacent strips shall not be cast for 24 hours.

BRIDGE DECKS AND CONCRETE OVERLAYS

413.32.08.02 Bonding Agent – The Contractor shall apply a pre-approved cementitious bonding slurry to the prepared sub-deck and repair concrete. The prepared concrete sub deck shall be in a saturated surface dry (SSD) state prior to slurry placement. The Contractor shall supply the necessary equipment such as water hoses and vacuum or oil free compressed air.

The cementitious bonding slurry is to consist of type GU portland cement mixed with a water/cement ratio not exceeding 0.38 by mass. The slurry must not exceed 3 mm in depth and be scrubbed into the substrate surface with coarse brooms; in particular no pooling will be permitted. The bonding slurry is to be applied immediately ahead of the overlay concrete placement and in a timely fashion so as not allow drying or setting up of the slurry prior to the placement of overlay concrete. Any areas to which the slurry has been applied, that in the opinion of the Ministry Representative exhibit drying or setting shall be cleaned of the bonding slurry and re-coated prior to the placement of deck overlay concrete.

The vertical faces at the edge of the scarified sub-deck surface; at construction joints; and at concrete/deck-joint interfaces for old bridge decks and the vertical faces at sub-deck and curb or parapet interface for new decks shall be coated with an epoxy bonding agent conforming to ASTM C881, Type V, Grade 2. The Class of bonding agent shall be appropriate for the temperature at the time of application. The bonding agent shall be applied in accordance with the manufacturer's instructions.

413.32.08.03 Interim Partial Strength – Overlay shall attain a minimum strength of at least 30 MPa before removal of the burlap and opening to traffic. All other requirements of seven day curing shall be adhered to. The interim strength tests shall be determined using field cured test cylinders cured in accordance with Clause 7.3.4 of CSA A23.2-3C.

SECTION 415

MANUFACTURE AND ERECTION OF PRECAST AND PRECAST PRESTRESSED CONCRETE MEMBERS

DESCRIPTION

415.01 Scope – This Section covers the manufacture and erection of precast and precast prestressed concrete members.

415.02 General

415.02.01 The manufacture and erection of precast and precast prestressed concrete members shall conform to the requirements of these specifications and details as shown on the Drawings.

415.02.02 Precast concrete elements shall be manufactured in plants certified to the current CSA A23.4 requirements in the appropriate category by a certification organization accredited by the Canadian Precast Prestressed Concrete Institute (CPCI) in the subject area of building products and structures. Certification shall be in effect prior to the beginning of Work, and maintained throughout the period of manufacture.

415.02.03 Materials and construction shall conform to the current CSA A23.4 and the current PCI “Manual for Quality Control for Plants and Production of Precast and Prestressed Concrete Products 1999”. Where there is a discrepancy between the requirements of these two standards, the more stringent shall apply.

415.03 Prefabrication Meeting – The Ministry will at its discretion, convene a prefabrication meeting with the Contractor to review issues such as, but not limited to, procedures on quality control, plant certification, concrete source and mix designs, use of Hydration Stabilization Admixtures (if applicable), mill certificates, alternate details and procedures, updated schedule for prefabrication and to confirm the Ministry’s requirements.

415.04 Working Drawings – Working drawings shall consist of the following:

- Shop drawings,
- Transportation details, and
- Erection drawings

Transportation details and erection drawings shall be prepared and sealed by a professional engineer registered with Association of Professional Engineers and Geoscientists of British Columbia (APEGBC).

Shop drawings shall be prepared and sealed by a professional engineer registered with APEGBC when the Contractor is responsible for the design of items that are detailed on the shop drawings.

Working drawings shall be in the same system of units as the design drawings.

Working drawings shall be on D size sheets approximately 560 mm (22") by 865 mm (34"), (one drawing per sheet). Lettering for notes and dimensions shall be at least 2.5 mm and 4 mm for headings. Drawings shall be legible when half-sized or microfilmed.

415.04.01 Shop Drawings – Shop drawings shall show all information and details needed for the fabrication of the members including, but not limited to, such items as member shapes and dimensions, mark numbers and general arrangement of member locations, mass, prestressed and non-prestressed reinforcement, embedments, openings, block outs, chamfers, recesses, finishes, concrete mix design, stressing details, special tolerances, special handling instructions, lifting details and lifting locations.

415.04.02 Transportation Details – Transportation details shall include such items as:

- Description of hauling and handling equipment,
- Weight of members,
- Length and height of loads,
- Location and method of member support, and engineering calculations where members are to be supported during transportation further from their ends than outlined in SS 415.48,
- Details for handling, storing, and loading of members.

415.04.03 Erection Drawings

Erection drawings shall show in detail the method of erection including, but not limited to, the following:

- Erection procedures
- Procedures for off loading of members upon delivery
- Details for temporary storage and support of members on site prior to erection
- Equipment to be used
- Layout or general arrangement drawing showing the layout of the members, equipment positioning, and access roads
- Crane make, model, and capacity charts, boom length(s) , crane placement, and access for transporting of members to crane(s)
- Radii and loads for crane lifts
- Rigging details
- Mass of members, rigging and special installation equipment
- Details for installation and removal of all falsework,

SECTION 415

temporary supports, temporary bearings, bracing, guys, dead-men, and lifting devices

- Attachments to the bridge members and bridge structure for temporary support and special launching equipment
- Detailed description of sequence of operations
- Details for special installation equipment such as a launching truss, launching nose, head frames, spreader beams and rollers
- Details for installation of members onto the permanent bearings
- Traffic control plan for roadway and rail traffic
- Details for protection of existing utilities affected by the erection procedures
- Layout and detail of fall protection and their sequence of installation.

The Contractor shall be responsible for the lateral stability of members and shall design and provide bracing as necessary until completion of the Work.

The erection drawings shall be complete in detail for all anticipated phases and conditions during erection and during the temporary support of members. The Contractor shall submit calculations upon request, to the Ministry Representative that demonstrate that allowable stresses are not exceeded in members, falsework, temporary bracing and temporary supports and that member capacities and final geometry will be correct. The calculations shall be sealed by the professional engineer that sealed the erection drawings.

Falsework, temporary supports and temporary bracing shall meet the requirements of CSA Standard S269.1 – 1975, “Falsework for Construction Purposes” and shall also meet all the requirements for falsework given in the applicable Clauses of the Workers Compensation Act, Occupational Health and Safety Regulations BC.

A professional engineer registered with (APEGBC) shall be responsible for any field designs and any changes made to the erection procedures. Field designs and changes to the erection procedures must be documented and sealed by the responsible professional engineer and must be available at the Site prior to the affected erection work being carried out.

Immediately before placement of loading on falsework, the Contractor must ensure that the falsework is inspected and a sealed engineering certificate is issued by a professional engineer registered with APEGBC which:

- Indicates the specific areas inspected, and
- Certifies that the falsework has been erected in accordance with the latest approved erection drawings and supplementary instructions.

MANUFACTURE AND ERECTION OF PRECAST AND PRESTRESSED CONCRETE MEMBERS

Prestressed concrete stringers shall not be set on their bearings, nor shall the bridge deck be cast, until 30 days after the casting of the stringers. If it is necessary to erect the stringers earlier, they shall be placed on temporary supports. Prestressed concrete twin cell box stringers up to a maximum length of 20 metres may be shipped and erected after 10 days if the specified 28 day compressive strength has been attained.

415.04.04 Submittals – The Contractor shall submit to the Ministry Representative three sets of all working drawings. These drawings shall be submitted at least fourteen days prior to the fabrication of the work. The Ministry Representative will review the drawings for general compliance with the contract requirements.

If modifications to the drawings are required, the Ministry Representative will return one set of drawings, marked up, to the Contractor. The Contractor shall re-submit three sets of revised drawings to the Ministry Representative.

If no exceptions are taken to the drawings, the Ministry Representative will return one set of reviewed drawings to the Contractor. The Contractor shall forward an additional two sets of the reviewed drawings to the Ministry Representative.

Shop drawings will not be reviewed without the transportation and erection drawings applicable to the members in question.

Any work done on materials ordered prior to the review of working drawings shall be at the Contractor's risk. Erection will not be allowed to proceed without the Ministry Representative's review of the method proposed.

Review of working drawings shall not relieve the Contractor of any responsibility for dimensions or detail or for carrying out the work in full accordance with the drawings and specifications.

415.05 Alternative Details – All details shall, in general, conform to those shown on the Drawings. Any proposed variation shall be submitted to the Ministry Representative in writing, with the reason for the variation, and any cost saving or extra cost. The Ministry may require the submission of Drawings prepared and sealed by a professional engineer registered with the Association of Professional Engineers and Geoscientists of British Columbia APEGBC).

If, in the opinion of the Ministry, the variation represents a clear improvement, it may be accepted without any price adjustment.

If the variation results in a product of equivalent quality, it may be accepted at the discretion of the Ministry. In this case any saving in cost to the Contractor (as determined by the Ministry) shall be passed on as a credit to the Ministry.

SECTION 415

415.06 Quality Control – The Contractor shall implement a quality control program to meet the Contract requirements.

415.07 Quality Assurance – The Ministry will implement a quality assurance program by auditing the Contractor's quality control program and by inspection at its discretion.

The Contractor shall notify the Ministry Representative at least 14 days before fabrication is to commence. In addition, the Contractor shall provide a minimum of 2 days notice to the Ministry Representative that a product will be available for inspection and/or certification by the Ministry's Inspector. If the product is not available or is not sufficiently complete for inspection/certification as notified, at the sole discretion of the Ministry Representative, the Contractor shall be charged stand-by costs for the Ministry's Inspector. The Contractor shall allow the Ministry's representatives access to all parts of work, and shall supply such information and assistance as is required. When the Ministry requests, the Contractor shall provide samples of any materials. Inspection by the Ministry Representative shall not relieve the Contractor from obligation to perform the work in accordance with the contract.

Concrete tests shall be in accordance with the current CSA A23.2. The Contractor shall make available at the plant a sheltered, heated space for the casting and storage of test cylinders, with curing tanks and a concrete cylinder testing machine.

The Ministry may reject any items which, in its opinion, do not comply with the requirements of this specification.

Each unit shall be certified as acceptable by a Ministry Inspector before it is shipped from the shop. This certification shall not relieve the Contractor of responsibility for subsequent damage or for defects which become apparent before the work is finally accepted by the Ministry. The Contractor shall provide 5 days notice to the Ministry Representative regarding intent to ship a unit or product and the product shall be made available for inspection prior to loading and shipping.

MATERIALS

415.11 Materials Supplied by the Contractor

415.11.01 Cement – Portland cement shall conform to the requirements of CAN/CSA A3000, Cementitious Materials Compendium.

415.11.02 Aggregates – Fine and Coarse Aggregates shall conform to the current CSA A23.1. Coarse aggregates shall not exceed 20 mm nominal size.

415.11.03 Water – Water shall conform to the current CSA A23.1. The mortars and tests shall be made in accordance with the current CSA A23.2.

415.11.04 Reinforcing Steel – All reinforcing steel shall

MANUFACTURE AND ERECTION OF PRECAST AND PRESTRESSED CONCRETE MEMBERS

be in accordance with SS 412 and the current CAN/CSA G30.18, ASTM A 82/A 82M and ASTM A 185/A 185M.

All reinforcing shall be of the lengths called for on the Drawings and all bends shall be made in accordance with SS 412.

All bending schedules shall be furnished by the Contractor for the Ministry's review and any material ordered before such review shall be at the Contractor's risk. The review of bending diagrams by the Ministry shall in no way relieve the Contractor of responsibility for the correctness thereof.

All reinforcing steel labelled "E" on the Drawings shall be epoxy-coated to the requirements of ASTM A 775 M and D 3963M.

415.11.05 Prestressing Steel – Pre-tensioning steel shall consist of seven-wire, uncoated, low relaxation strands as called for on the Drawings and complying with the requirements of the current ASTM A 416M.

All strands for each project shall be obtained from one mill, and preferably strands from one heat shall be used for one project. Each reel of strand shall be identified by a secure tag showing the size of strand, CSA or ASTM Designation number, heat number, and name or mark of the manufacturer.

The Contractor shall supply to the Ministry Representative, for each heat number, one set of the standard mill test reports. Strands shall be protected at all times to prevent corrosion and shall be dry and clean (free from scale, rust, oil, soap, grease, and other deleterious materials) immediately before the concrete is placed. No strand which has previously been tensioned or gripped by strand chucks shall be incorporated into the members.

415.11.06 Admixtures – Chemical admixtures shall conform to the current ASTM C 494. Air-entraining admixtures shall conform to the current ASTM C 260.

Water reducing admixtures shall be of a lignosulfonic acid or salt, or hydroxylated carboxylic acid or salt.

Type B, Retarding or Type D, Water-Reducing and Retarding (Hydration Stabilizing) Admixtures conforming to the requirements of ASTM C 494 shall not be incorporated into the mix design and/or added to the concrete without the acceptance of the Ministry Representative. When accepted by the Ministry Representative, the guidelines given in SS 415.37, SS 415.40.01 and SS 415.42.01 shall apply.

415.12 Storage of Materials – All materials shall be stored in accordance with the requirements of the current CSA A23.1. Cement shipments shall be used in the order in which they are received.

415.13 Premixed Aggregates – Pre-mixed aggregates in which the fine and coarse aggregates are combined in definite proportions will be permitted provided that the

SECTION 415

aggregates are delivered in batches directly to the hopper of the concrete mixer. Pre-mixed aggregates shall be transported and delivered in batches, each containing the correct quantity for one batch of concrete. At no time after the fine and coarse aggregates are combined shall any batch come in contact with or intermingle with any other batch.

415.14 Forms – All exterior forms shall be of steel and shall be mortar-tight and of sufficient rigidity to prevent distortion due to incidental loadings during construction. Forms for skewed ends may be of rigid steel-reinforced plywood.

Forms shall produce 20 mm chamfers and fillets as shown on the Drawings.

415.15 Ministry's Office – Except for "on site" precasting work, where an office is already provided under the general contract, the Contractor shall provide at the point of manufacture a suitable lock-up office for the sole use of the Ministry.

The office shall be weatherproof and reasonably soundproof and provided with ample window area and ventilation. Location of the office shall be acceptable to the Ministry. The office shall measure not less than 3 m x 4 m. In the event that the office is to be used concurrently with other inspection agencies, the minimum area required for Ministry's use shall be 3 m x 4 m. The Contractor shall install satisfactory heat and lights and provide a telephone and a draughting table 1 m x 2.5 m in size with a plywood top, desk 0.75 m x 1 m, two chairs, drafting stool and one square metre of shelves.

Long distance calls made by Ministry personnel will be to the Ministry's account.

The Contractor shall, during the life of the work, regularly clean and properly maintain, heat and light to the office.

The office and contents shall be for the use of the Ministry for the duration of the work and may, if necessary, be used concurrently with other inspection agencies.

CONSTRUCTION

415.31 Reinforcing Steel – All reinforcing bars shall be accurately placed in the positions shown on the Drawings and firmly held during placing and setting of the concrete. Tolerances shall be as specified by the current CSA A23.4.

When placed in the work the reinforcing steel shall be free from dirt, rust, loose scale, paint, oil, or other foreign materials. Bars shall be tied at all intersections except that where spacing is less than 300 mm, alternate intersections shall be tied. Form clearance shall be maintained by stays, ties, hangers or other approved supports. Before placing concrete, the placing and securing of reinforcing in the forms shall be inspected by the Ministry Representative.

All reinforcing shall be placed in the full lengths called for

MANUFACTURE AND ERECTION OF PRECAST AND PRESTRESSED CONCRETE MEMBERS

on the Drawings. Splicing of bars will not be permitted unless acceptable to the Ministry Representative. Splices shall be staggered. Unless otherwise shown or called for on the Drawings, splices shall be made by lapping in accordance with the requirements of SS 412. The bars shall be placed so as to maintain the minimum specified clearances between bars and the concrete surface. Welding of reinforcing steel shall be done only if called for on the Drawings or accepted by the Ministry Representative.

Tack welding of reinforcing steel, if permitted, shall be in accordance with the current CSA W186-M.

415.32 Stressing – The dials of gauges shall be at least 200 mm in diameter. Gauges shall be calibrated with the hoses and jacks with which they are to be used, by an approved testing agency. The calibration must have been performed within the previous 6 months of use or 12 months maximum. Before stressing commences, certified calibration curves shall be furnished to the Ministry Representative.

If during the work any gauges give erratic results, the tension system or tension device shall be recalibrated.

The Contractor shall schedule the work so that placement of concrete follows tensioning of strands within 24 hours. In cases of unavoidable delay, a maximum period of 80 hours will be allowed, provided that the strands do not show unacceptable corrosion (see current PCI "Manual for Quality Control for Plants and Production of Precast and Prestressed Concrete Products").

Before tensioning, an initial force shall be applied to each strand to equalize stresses and eliminate slack. This force shall not exceed 22 kN. After the initial tension forces have been applied, each strand shall be marked at the outer end of each chuck as a reference line from which the elongation of the strand can be measured.

The method of tensioning shall be such that the specified tension is maintained in the strands until the forces in the strands are transferred to the concrete member(s). The maximum jacking load in each strand shall be 80% of the ultimate strength of the strand.

A tensioning force shall be determined both by reading the jacking load on the calibrated gauge and by measuring the elongation of the strand. When the difference between the two methods is greater than 5%, the cause of the discrepancy shall be ascertained and corrected.

Elongations of strands shall be calculated and shown on the working drawings. Calculations for elongations shall include appropriate allowances for possible slippage or relaxation of the anchorages, friction at hold down points, temperature difference, and strand relaxation.

415.33 Forms – The design of the forms shall take into account the effect of vibration of concrete as it is placed.

SECTION 415

All exterior forms shall be set and maintained true to the designated lines until the concrete has hardened. When forms are unsatisfactory in any way, either before or during the placing of concrete, the Ministry Representative may order the work stopped until the defects have been corrected.

The shape, strength, rigidity, mortar-tightness and surface smoothness of re-used forms shall be maintained at all times. Any warped or bulged formwork must be realigned before being re-used. Forms which are unsatisfactory in any respect shall not be reused.

Void forms shall be of an approved product and shall be anchored firmly by a method acceptable to the Ministry Representative, to prevent displacement during the placing of the concrete. Any member with a void out of position in excess of the specified tolerance will be rejected.

Exterior forms shall be treated in moderation with form oil before placing the concrete. Any material which will adhere to or discolour the concrete shall not be used.

Side forms and any attachments which would obstruct strain of the members shall be removed before transfer of stress.

415.34 Admixtures – The Contractor shall add sufficient air-entraining agent to entrain 5% \pm 1% air as determined by an air-meter used in accordance with the current CSA A23.2.

The use of other admixtures, such as water-reducing agents or superplasticizer, shall be subject to the acceptance of the Ministry Representative.

Type B, Retarding or Type D, Water-Reducing and Retarding (Hydration Stabilizing) Admixtures shall not be incorporated into the mix design and/or added to the concrete without the acceptance of the Ministry Representative. When accepted by the Ministry Representative, the guidelines given in SS 415.37, SS 415.40.01 and SS 415.42.01 shall apply.

415.35 Measurement of Materials – Measurement of materials shall conform to the current CSA A23.1. The Contractor shall produce a certificate or report of inspection from a weights and measures approved, independent testing authority, and which is not more than 6 months old. The certificate or report will be accepted as proof of accuracy for the batching equipment. Cement in standard packages need not be weighed.

The surface moisture shall be determined in accordance with the current CSA A23.2 and the batch weights of aggregates and water adjusted accordingly.

415.36 Mix Requirements – Minimum compressive strength at time of transfer of stress to the concrete and at 28 days as determined by the current CSA A23.2 shall be as called for on the Drawings. In any case, the force in the prestressing tendons shall not be transferred to the

MANUFACTURE AND ERECTION OF PRECAST AND PRESTRESSED CONCRETE MEMBERS

concrete until the compressive strength of the concrete is at least 25 MPa for pretensioned components and 20 MPa for post-tensioned components.

Slump measurement shall be determined by the current CSA A23.2. The mix design shall specify the slump and the tolerances in the measured slump shall be \pm 20 mm for superplasticized concrete. Slump shall not exceed 200 mm for superplasticized concrete and shall be measured within 5 minutes after discharge from the mixer.

In order to minimize shrinkage and creep the cement/aggregate ratio shall be kept as low as is consistent with strength requirements.

415.37 Batching and Mixing – The batching plant and mixing of concrete shall conform to the current CSA A23.1.

Mixing shall begin within 15 minutes after the cement has been added either to the water or aggregate.

Within 30 minutes after the introduction of the mixing water to the cement and aggregate, or the cement to the aggregate, the concrete shall be placed in its final position in the forms. In hot weather or under other conditions contributing to quick stiffening of the concrete, the maximum allowable time may be reduced by the Ministry Representative.

Time of placement extensions will be considered on a case by case basis and may require the use of Hydration Stabilizing Admixtures (HSA's) conforming to the requirements of ASTM C 494 Type B, Retarding or Type D, Water-Reducing and Retarding Admixtures. If accepted by the Ministry Representative, guidelines for the use of HSA's shall be as follows:

- HSA modified concrete when used shall be fully discharged and placed in its final position within 90 minutes after the introduction of water to the cement and aggregate.
- All concrete in a given precast element shall be placed in its final position before 90 minutes.
- When HSA's are used, these time extensions are subject to preconstruction trials being conducted by the Contractor, to establish the appropriate HSA dosage to provide suitable extended slump life of concrete, without increasing the water/cementitious ratio of the concrete above that which would be required if HSA's were not used. The use of HSA's shall in no instance modify the maximum concrete temperature required at time of placement. A one time only addition of HSA will be allowed. This will be during initial batching of the concrete or immediately at completion of batching as recommended by the admixture manufacturer. Addition of HSA at any other time will be cause for rejection of the concrete.

SECTION 415

Concrete mixing and transporting equipment shall be capable of placing concrete in the forms at the rate of 20 cubic metres per hour. Batch delivery shall be uniform and at a maximum interval of 10 minutes.

The maximum size of each batch shall not exceed the maximum rated capacity of the mixer as stated by the manufacturer of the mixer.

Concrete when placed in the form shall have a temperature not less than 10°C nor greater than 25°C.

415.38 Handling and Placing Concrete – In preparation for the placing of concrete, all construction debris and extraneous matter shall be removed from the interior of forms. Struts, stays and braces inside the forms shall be kept to a minimum and entirely removed when the concrete placing has reached an elevation rendering their service unnecessary.

Concrete shall be handled and placed in accordance with the requirements of the current CSA A23.1 and shall be placed in the shortest possible time after mixing is completed. When rectangular void forms are used, concrete under voids shall be placed and compacted before void forms are in position.

Concrete may be deposited a maximum of 2 m without the use of pipes, provided, when required, suitable measures are taken to prevent segregation and premature coating of upper reinforcing steel. When pipes are used they shall, as far as practicable, be kept full of concrete during placing and their lower ends shall be kept buried in the newly placed concrete.

After initial set of the concrete, the forms shall not be jarred and no stress shall be placed on reinforcing bars which project.

415.39 Vibration – Concrete, during and immediately after depositing, shall be thoroughly compacted. The compaction shall be accomplished by mechanical vibration subject to the following provisions:

- a) Vibration shall be internal for all accessible parts and shall be external for inaccessible parts.
- b) Vibrators shall be of a type and design acceptable to the Ministry. They shall be capable of transmitting vibration to the concrete at frequencies recommended in the current CSA A23.1.
- c) The intensity of vibration shall be such as to visibly affect a mass of concrete of 50 mm slump over a radius of at least 500 mm.
- d) The Contractor shall provide a sufficient number of vibrators to properly compact each batch immediately after it is placed in the forms.
- e) Vibrators shall be manipulated so as to thoroughly work the concrete around the reinforcing and embedded

MANUFACTURE AND ERECTION OF PRECAST AND PRESTRESSED CONCRETE MEMBERS

fixtures and into the corners and angles of the forms.

Vibration shall be applied at the point of deposit and in the area of freshly deposited concrete. The vibrators shall be inserted into and withdrawn from the concrete slowly. The vibration shall be of sufficient duration and intensity to thoroughly compact the concrete, but shall not be continued so as to cause segregation. Vibration shall not be continued at any one point to the extent that localized areas of grout are formed.

Application of vibrators shall be at points uniformly spaced and not farther apart than twice the radius over which the vibration is visibly effective.

f) Vibration shall not be applied directly or through the reinforcement to sections or layers of concrete which have hardened to the degree that the concrete ceases to be plastic under vibration. It shall not be used to make concrete flow in the forms over distances so great as to cause segregation, and vibrators shall not be used to transport concrete in the forms.

g) Vibration shall be supplemented by such spading as is necessary to ensure a smooth surface and dense concrete along form surfaces and in corners and locations impossible to reach with the vibrators.

h) Vibrator heads shall be smaller than the minimum clear distance between prestressing strands.

415.40 Test Cylinders – The Contractor shall make available, as may be required by the Ministry Representative, samples of the concrete used in casting the members.

Further, the Contractor shall take samples and make test cylinders in the presence of the Ministry Representative and in accordance with the current CSA A23.2-1C, -3C and -9C. At least 8 cylinders per casting bed shall be made for testing. At the discretion of the Ministry Representative, depending on the quantity and type of element being cast, the number of cylinders may be reduced.

415.40.01 Release Strength – Two cylinders from each end of the casting bed shall be cured in the same manner as the members and tested by the Contractor under the discretionary observation of the Ministry Representative at the Contractor's plant to assess the strength of the concrete at the time of transfer of force to the concrete. Only one cylinder from each end need be tested if the average strength of the two cylinders is equal to or greater than the required release strength at transfer and no test cylinder is more than 1.4 MPa below the release strength. No transfer of force shall occur without the acceptance of the Ministry Representative. At the discretion of the Ministry Representative, depending on the quantity and type of element being cast, the number of cylinders may be reduced.

SECTION 415

If all release cylinders are tested and the release strength has not been attained, further testing with an impact hammer shall be allowed, provided a written procedure acceptable to the Ministry Representative is provided by the Contractor. The procedure shall correlate readings from areas of a prestressed girder where the release strength has been determined by concrete test cylinders with similar areas on the girder in question. If this situation occurs, extra pairs of release cylinders shall be made on future casts until confidence in determining the release strength is re-established.

When HSA's are incorporated into the mix design, pre-construction tests shall be conducted to determine the rate of early strength development for the selected concrete mix design. Tests shall be repeated when there is a change in the HSA dosage rate.

415.40.02 28 Day Strength – Two cylinders from each end of the casting bed shall be identified as "acceptance cylinders" and shall be cured in the Contractor's curing tanks. These cylinders shall be tested by the Contractor under the discretionary observation of the Ministry Representative to determine the twenty-eight day strengths. The strength of the concrete in the member shall be taken as the average of the compressive strength of the "acceptance cylinders", however, no individual cylinder shall be more than 3.5 MPa below the specified strength and the average strength shall equal or exceed the 28 day strength.

415.40.03 Additional Cylinders – For special cases, extra cylinders shall be made and tested if required by the Ministry Representative. In the case of ready mix, and plant mixed concrete with no established records, extra cylinders, in addition to the release strength or 28 day strength cylinders, shall be made from each load.

415.41 Surface Finish – Throughout the work, special precautions shall be employed in formwork and concrete placing to produce a smooth and dense concrete. Exposed surfaces shall be as free as possible from form marks, fins, honey-combing and pock marking. Only a minimum amount of pointing will be allowed. Poor surface finish upon the removal of the forms shall be sufficient cause for the rejection of any member. All exposed edges shall be chamfered unless otherwise noted on the Drawings.

Roadway and surfaces to be bonded to shall be rough screeded by wood floating following initial strike off. Surfaces to be bonded to shall be sandblasted or exposed with chemical retarder and water blasted to remove all laitance and foreign matter and to roughen the surface. The amplitude of the surface roughness shall be equal to one third of the nominal size of the concrete coarse aggregate or 6 mm, whichever is less. Loose sand and debris shall be washed or blown off. Water, cement or proprietary topping material shall not be added to the surface during finishing.

MANUFACTURE AND ERECTION OF PRECAST AND PRESTRESSED CONCRETE MEMBERS

Walkway surfaces shall be given a coarse transverse broomed finish following initial screeding and floating. Roadway surfaces not requiring any wearing surface shall be given a tined surface in accordance with SS 413.31.02. Roadways receiving a membrane shall be finished in accordance with SS 419.33.

The outer surfaces of the outside stringers and any other surfaces indicated on the Drawings shall be given a Class 2 finish in accordance with SS 211.17.

415.42 Curing – Precast or precast prestressed members may be cured by steam or heat as outlined herein.

415.42.01 Steam Curing – The concrete shall attain its initial set before application of steam (generally 2 to 4 hours after the final placement of concrete or as justified by previous experience or in accordance with ASTM C403/C403M-06 Standard Test Method for Time of Setting of Concrete Mixtures by Penetration Resistance, all to the acceptance of the Ministry Representative.

If HSA's are used in the mix design, time to attain initial set after concrete has been placed may exceed that required for conventional concrete. The concrete shall have attained initial set before the application of steam.

After the placement of concrete, sufficient steam shall be applied during initial curing to hold the air surrounding the member at a temperature not less than 13°C.

Steam curing shall be done within a suitable enclosure to contain the steam and minimize moisture and heat losses. The enclosure shall allow free circulation of steam around the sides and tops of members and shall not be in contact with the member.

Steam at the outlets shall be at 100% relative humidity and low pressure. Application of the steam shall not be directly on the concrete or test cylinders and shall be from outlets distributed uniformly along the whole length of the member.

During application of the steam the ambient air temperature shall increase at a rate not to exceed 22°C per hour until an optimum temperature of 55°C is reached. In no case shall the ambient curing temperature exceed 80°C. The maximum temperature shall be held until the concrete has reached the transfer strength. In discontinuing the steam, the ambient air temperature shall not decrease at a rate greater than 33°C per hour until a temperature has been reached about 11°C above the temperature of the air to which the concrete will be exposed. The forms shall not be stripped until the completion of this cooling off period.

Provision shall be made for checking the ambient air temperature either by placing minimum-maximum thermometers under the enclosure or periodically checking with hand thermometers.

415.42.02 Curing With Radiant Heat and Moisture – Curing with radiant heat and moisture shall be done by

SECTION 415

heating the casting area in combination with the continuous application of moisture.

Heat shall be applied by means of pipes circulating steam, hot oil or hot water or by electric heating elements. Pipes shall not be in contact with concrete, form surfaces or test cylinders.

Moisture shall be applied by a continuous sprinkling to a cover of burlap or cotton matting or any other approved method for keeping the members continuously moist.

An auxiliary cover in addition to the moisture retaining cover shall be used above the entire bed to retain the heat. This cover shall be supported at a sufficient distance above the member to allow circulation of the heat.

The cycle of application of heat, temperature limitations, reduction of temperatures and use of recording thermometers shall be similar to the cycle specified for steam curing.

415.42.03 Additional Curing Requirements – Precast non-prestressed members shall be cured in accordance with the requirements of CSA A23.1 Section 7.4.1.

415.43 Draped Strands – Where called for on the Drawings strands shall be draped in accordance with the current CSA A23.4.

415.44 Transfer of Force to Concrete Members – The transfer of the forces in the strands to the concrete member(s) shall be in accordance with the current CSA A23.4 (section on Detensioning).

415.45 Protective Coating for Ends of Strands – After completion of concrete curing the ends of tensile strands shall be ground flush with the concrete surface. Where the ends of the members are to be embedded in concrete, the ends of the strands shall be painted with two coats of an organic zinc rich paint acceptable to the Ministry. Where the ends of the members are not to be embedded in concrete, the ends of the members shall be covered with thixotropic epoxy to provide at least 3 mm cover for a band width of 50 mm on each side of all strands. This material is to be applied in accordance with the manufacturer's recommendations.

415.46 Tolerances – For bridge stringers, the tolerances specified in the PCI "Manual for Quality Control for Plants and Production of Precast and Prestressed Concrete Products 1999". shall be modified so that the length of each member, measured parallel to the longitudinal axis, to extreme corners, at 20°C, does not exceed the specified length by more than 10 mm / 10 m (25 mm maximum).

The Contractor shall employ an adequate method of checking tolerances both before and after placement of concrete. Review of the method of checking tolerances by the Ministry Representative will not limit the Contractor's responsibility for the accuracy of the members.

MANUFACTURE AND ERECTION OF PRECAST AND PRESTRESSED CONCRETE MEMBERS

415.47 Repairs to Members – Defective areas should be repaired immediately following removal of forms and before detensioning of strands.

If a defect is deemed to be a structural repair and meets the criteria stated in CSA A23.4 Section 33.3, notification shall be provided to the Ministry Representative and/or Inspector regarding the nature and extent of the defect. The Contactor shall follow the repair procedures described in CSA A23.4 Section 33.3 and submit the proposed repair procedure to the Ministry Representative for review and acceptance prior to any repair work being undertaken.

Holes, honeycomb spots, etc., shall be treated as for Class 2 finish in accordance with SS 211.17. The method of repair for cracks, broken corners and edges, bulges and other defects shall be submitted to the Ministry Representative for review and acceptance. In any case, the Ministry Representative/Inspector shall be notified regarding all repairs to precast and precast prestressed members.

415.48 Handling, Storing and Loading of Members – Stringers shall at all times be kept in their normal upright position during handling, storage and transportation. They shall be picked up by means of vertical forces or forces inclined towards the opposite ends of the members by no more than 30° from the vertical, applied to lifting devices near the ends of the stringers. I-beams shall be adequately stiffened during lifting and transportation.

Stored stringers shall rest on unyielding level supports near the ends of the stringers.

When loaded for transportation, members shall be supported so that they will not be overstressed. In general, beams with straight strands may be supported up to one-tenth of their lengths from each end, whereas beams with draped strands should be supported at their bearings. If the Contractor believes that it is possible to safely support members further from their ends, the Contractor shall submit to the Ministry Representative, sketch(es), sealed by a registered professional engineer, showing the proposed support arrangement. Adequacy of support shall be based on the following assumptions:

- 100% impact on cantilevering ends, when checking stresses at supports,
- 50% negative impact on the whole member, when checking stress near midspan,
- 50% of prestress losses at time of shipping (unless circumstances dictate otherwise),
- allowable tensile stress = $0.5\sqrt{f_c}$
- allowable compressive stress = $0.6f_c$
- where f_c = estimated strength of concrete at time of shipping.

SECTION 415

Such sketch(es) shall be submitted at the time of submittal of the working drawings (see SS 415.04). Members transported on supports further from their ends than outlined above, without the submittal of sketch(es) acceptable to the Ministry, will be rejected.

Piles shall be lifted in the horizontal position at the pick-up positions shown on the drawings and at no other points. When stacking for storage or for delivery, piles shall be supported at the pick up points. They shall be handled carefully, avoiding dropping and jarring and avoiding surface abrasions or other damage.

Any member damaged so as to be, in the opinion of the Ministry Representative, unfit for the use for which it is intended shall be replaced at the Contractor's own expense.

415.49 Placement of Concrete in Keyways – Keyways between box stringers shall be clean and shall be saturated surface dry surfaces, before being filled with concrete.

Concrete in keyways shall attain a strength of at least 15 MPa before light traffic such as one-tonne trucks are allowed on the bridge, and at least 25 MPa before heavy loads such as concrete trucks are allowed on the bridge.

415.50 Post-Tensioning – All post-tensioning shall be done in accordance with the SS 416 – "Manufacture and Installation of Post-Tensioned Concrete Members".

QUALITY CONTROL PROGRAM

415.61 Quality Control Program – These Subsections describe the general Quality Control Program required by the Ministry of Transportation for any Fabricator undertaking the fabrication of permanent precast concrete bridge components.

The term "Quality Control" defines those activities that the Fabricator performs to conform to the contract.

The term "Quality Assurance" defines those activities that the Ministry performs to ensure conformance to the contract.

These Subsections contain statements of the Quality Objectives and Policies that the Ministry considers essential for successful and economical quality management. They also outline the Procedures and Documentation to implement and confirm that the Objectives are met.

The provisions of the Quality Control Program set forth in these Subsections shall apply to all precast concrete bridge components contracted by or for the Ministry.

These Subsections require the establishment of a Quality Organization with the responsibility for the successful and timely implementation of all necessary Quality Control activities. Some positions shown in the Suggested Organization Chart (see Figure 1) may be held by the same individual. For example, the General Manager may also be the Contract Administrative Manager and the Purchasing Manager. The Plant Superintendent may also

MANUFACTURE AND ERECTION OF PRECAST AND PRESTRESSED CONCRETE MEMBERS

be the Receiver and the Structural Supervisor.

415.62 Quality Objectives and Policies

415.62.01 Quality Objectives – The Quality Objectives of the Ministry of Transportation cover all precast concrete bridge components produced under contract to the Ministry, as follows:

- a) Completed products shall conform fully to the governing Codes and Specifications stipulated in the contract document.
- b) The Quality Control Program shall be fully integrated into the ongoing manufacturing activities of the Fabricator.
- c) The operations of the Quality Control Program shall protect the interests of the Ministry with respect to scheduled delivery date and contracted price.

415.62.02 Quality Policy – It is Ministry policy that the interests of the Fabricator and the Ministry coincide when a product meets the Quality requirements of the contract, is delivered on time, and is produced in a cost-effective manner.

The Quality Control Program is an essential part of this policy. It is based on the fact that the best way to do any job is to do it right the first time. This applies to all stages of the design, drafting, procurement, manufacturing and testing of the product.

The Quality Control Program involves all Ministry and Fabricator personnel. Their activities must be consistent with the Quality Objectives of the Ministry.

A Quality Control Manager shall be appointed with defined responsibilities in resolving quality matters and shall report to a senior management level. At each hold point, the Quality Control Manager shall:

- Document the successful completion of each stage as it progresses through fabrication and erection.
- Identify and report nonconforming components.
- Initiate or recommend disposition of nonconforming components.
- Verify corrections.

Any persons assigned to perform quality control inspections shall be other than those performing or directly supervising the work and they shall not report directly to immediate supervisors responsible for producing the work.

The Quality Control Program is not subordinate to any design, drafting, procurement, manufacturing and testing activities, it is an essential part of them.

415.63 Scope of the Quality Control Programs – This Quality Control Program governs the fabrication of precast concrete bridge components for the Ministry of Transportation. The Suggested Organization Chart is shown in Figure 1

SECTION 415

The General Manager shall be responsible for:

- adhering to this Quality Control Program in all respects.
- ensuring that completed bridge components shall conform fully to the applicable design and fabrication codes stipulated in the Contract.
- ensuring that all required documentation is produced according to this Quality Control Program.

415.64 Range of Capability – Within the Company, there shall be the necessary knowledge, skill (in-house or on a contract basis) and equipment to do the following work on precast concrete bridge components:

- Design of lifting and erection devices not shown on drawings
- Preparation of shop fabrication drawings
- Preparation of bills of material
- Preparation of material requisitions and purchase orders
- Receiving, checking and storing materials for bridges
- Layout, form set-up, reinforcing steel, prestressing and post-tensioning
- Mix designs, batching, mixing, placing and curing of concrete
- Sampling, testing, making and breaking of concrete test cylinders
- Dimensional checking and verification
- Resolution of non-conformances
- Documentation of all stages of work with capability of tracing all major components
- Finishing, patching, storing and shipping
- Erection of bridge components

415.65 Drawings and Specifications – The Chief Design Engineer shall be responsible for:

- the design and location of lifthooks and the preparation of stressing sheets for prestressing or post-tensioning; and for the design of the erection procedures and any special erection equipment needed.

The Chief Draftsperson shall be responsible for:

- obtaining the latest revision of the design Drawings and Specifications for the work.
- submitting shop drawings and erection drawings to the Ministry for acceptance before commencement of the work.
- preparing material requisitions containing a full description of the material sizes, material specifications, and certifications required for conformance to the contract.

MANUFACTURE AND ERECTION OF PRECAST AND PRESTRESSED CONCRETE MEMBERS

- delivering the material requisitions to the Purchasing Manager in ample time to permit ordering, delivery and documentation and not delay the progress of the work.
- issuing requisitions for all sub-contracted drafting work and shall ensure that all conditions of the Contract are part of such sub-contracts.

415.66 Material Control – All materials for bridge components shall be ordered by the Purchasing Manager in full conformance with the material requisitions provided by the Chief Draftsperson.

The Purchase Orders shall contain all information necessary to ensure that materials purchased will comply fully with the terms of the Contract. Where mill certificates and test reports are required, it shall be so stated on the Purchase Order. Instructions shall state when the certificates and reports are to be delivered to the Fabricator.

If a supplier proposes a substitute for any material, the Purchasing Manager shall refer the proposed substitution to the Chief Design Engineer for review. If the substitute is acceptable to the Ministry, the Chief Draftsperson shall amend all drawings and requisitions, withdraw old issues and issue the new versions.

The Receiver shall:

- inspect all materials on arrival for conformance with the Purchase Orders.
- confirm that mill certificates and test reports are provided and that they correctly identify the materials delivered.
- arrange with the Plant Superintendent to store all materials for the Contract in segregated areas.
- ensure all materials are clearly identified with the Contract.
- issue a non-conformance report covering overage, shortage or damage to the materials. Copies of the report shall be provided to the Purchasing Manager and the Quality Control Manager.

The Purchasing Manager shall deliver all documentation to the Quality Control Manager for inclusion in the Quality Control file for the Contract.

415.67 Pre-Pour Inspection and Reporting – The Quality Control Manager shall ensure only documented materials are used for the contract.

Forms used in the casting of members shall be inspected prior to use and shall meet all the requirements of the current CSA_A23.4 and the special provisions of the contract Specifications.

Reinforcement shall be fabricated and placed to satisfy the current CSA_A23.4 and the detailed shop drawings for quantity and spacing. Any reinforcement used to anchor

SECTION 415

cast in hardware by being welded to it will require the Fabricator to be certified to CSA W186-M.

All cast in hardware shall be fabricated and placed according to the current CSA_A23.4. Any hardware requiring welding, including stud welding, will require the fabricator to be certified under CSA W47.1 Division 3 and have approved procedures for each weld.

All pre-tensioning operations shall be done according to the current CSA_A23.4. Care shall be taken to properly execute, supervise and record the operations in a clear and legible manner.

The Quality Control Manager shall file a written report of verification with the General Manager and report any non-conformance that may exist on any of the above items in SS 415.67.

415.68 Concrete Control – All materials used in concrete mixes such as cement, fine and coarse aggregates, and admixtures, shall have representative certificates that can verify the quality of them.

Production of concrete shall be done according to the specifications. Records shall be kept of the mix type and quantity used in each pour.

Handling, placing and vibration of freshly mixed concrete shall be done as per specifications. Any variations and interruptions in the process shall be recorded.

The sampling and testing of freshly mixed concrete shall be in accordance with the specifications and procedures laid out in the current CSA_A23.2. Concrete test cylinders shall be made, cured and tested in accordance with the Specifications.

Reports for all concrete testing shall be kept on file and all non-conformities reported.

415.69 Post Pour Inspection and Reporting – Dimensions of all members shall be verified to ensure tolerances are being maintained as per the specifications.

Verification shall be made of finishes, blockouts, keyways, projecting rebar, sole plates and protection of the cut off strands.

Camber shall be monitored at release and 28 days.

Members shall be stored according to the fabricator's documented procedures.

Members shall only be allowed to be shipped out for erection after they have been approved by both Quality Control and Quality Assurance.

Records shall be kept on file for all items in this section.

415.70 Correction of Non-Conformities – When a non-conformance is encountered, the Quality Control Manager shall determine a recommended disposition and submit such disposition to the the Ministry Representative for acceptance as quickly as possible.

MANUFACTURE AND ERECTION OF PRECAST AND PRESTRESSED CONCRETE MEMBERS

If there is non-conformance to the material specification stipulated in the Purchase Order, the Purchasing Manager shall immediately find out the reasons for the delivery of non-conforming materials. If the material is of a grade superior to that ordered, the Quality Control Manager and the Chief Engineer shall be notified. They shall verify that the material is an acceptable alternative in all respects. This verification shall include consultation with the Ministry. If the material is of a grade inferior to that ordered, it shall be rejected and the correct material or a superior material shall be obtained.

If there is non-conformance of material delivery that will delay production, the Contract Administrative Manager and Plant Superintendent shall be notified immediately. They shall be given revised delivery dates for the adjustment of production scheduling. The General Manager shall determine the alternatives available and shall notify the Ministry.

If there are pre-pour non-conformities in form set-up, prestressing, rebar placement, hardware and blockout size and location, the Quality Control Manager and Structural Supervisor shall immediately review the non-conformance and notify the Chief Design Engineer who may require further investigation prior to submitting corrective action to the Ministry for acceptance. If the necessary corrective action will result in delay to production, the General Manager shall be notified for adjustment to the production schedule. The Plant Superintendent shall inform the Quality Control Manager when the corrective actions are being done so that conformance can be verified and the non-conformance report cancelled.

If there are post-pour non-conformities such as honeycombs or large voids after form removal, before de-tensioning the Quality Control Manager shall notify the Chief Design Engineer who will investigate and submit corrective action to the Ministry for acceptance. Other non-conformities such as low concrete strength, dimensional errors due to faulty forms, variations in camber from design and missing hardware shall all be reported by the Quality Control Manager.

415.71 Welding – All welding on structural components shall conform to the Welding Standards of the Contractor as Approved by the Canadian Welding Bureau.

All welding consumables shall conform to the Approved Welding Standards and shall be received, stored and conditioned according to the applicable Welding Standards.

All welders and welding operators on the contract shall be qualified under the requirements of the current CSA W47.1 division 3 or better.

All welding of reinforcing steel, when acceptable to the Ministry, shall be done by fabricators certified under CSA W186.

SECTION 415

415.72 Calibration of Measurement and Test

Equipment – All measurement and testing equipment owned by the Fabricator and used in the Quality Control Program shall be calibrated and re-calibrated at the intervals and in the manner stipulated in the current CSA A23.4.

When the concrete testing services are contracted to a Qualified testing firm according to the latest edition of CSA A283, they shall confirm in writing to the Ministry that all their measurement and test equipment used in the testing is properly calibrated. If requested, they shall furnish copies of the calibration test data for inclusion in the contract documentation.

415.73 Records Retention – The Fabricator's Record File for each Contract shall contain the pertinent drawings, purchase orders, bills of material, material mill certificates, test reports, Quality Control documents, and certificates of compliance.

The Fabricator's Record File shall be made available to the Ministry's Inspectors upon request.

Items in the Fabricator's Record File shall be retained as per company policy.

The Quality Control Manager shall ensure that each file is complete in all respects before it is placed in the Company archives.

415.74 Hold Points – In planning the work flow, it is essential to coordinate with the Ministry Inspector to decide "hold" points for inspection. A list of hold points shall be drawn up by the Fabricator and the Ministry at a prefabrication meeting. The Ministry should be continuously informed of progress so that delays are minimized.

The "hold" points will typically include, but not be limited to, the following:

- verification of form size, quality and layout

MANUFACTURE AND ERECTION OF PRECAST AND PRESTRESSED CONCRETE MEMBERS

- after stressing, rebar and hardware placement
- prior to form close up
- sampling and testing of concrete
- release cylinders
- after patching and finishing
- 28 day cylinder results
- shipping arrangements.

It must be understood that work will not proceed past a "hold" point until it has been signed off by Quality Control and Quality Assurance. Reports must be completed promptly.

(Refer to the the current edition of the PCI Manual – Publication MNL-116 for "Sample Record Forms")

MEASUREMENT

415.81 Precast Concrete Members – Precast Concrete members will be measured by EACH of the type specified.

PAYMENT

415.91 Supply and Fabrication – Payment for supply and fabrication of PRECAST CONCRETE MEMBERS will be made at the lump sum price bid. Payment shall be for quality control, shop drawings, supply and placing of concrete, formwork, reinforcing steel, prestressing strands and any required inserts. Payment shall also cover tensioning, curing, release, stripping of forms, patching as necessary and storage of members.

415.92 Shipping and Erection – Payment for shipping and erection of PRECAST CONCRETE MEMBERS will be made at the lump sum price bid. Payment shall be for quality control, erection drawings, transportation drawings, loading, shipping and unloading of members. Payment shall also cover falsework and erection of members. For box stringers, payment shall also cover the supply and placement of sealing strips between stringers.

FIGURE 1

SUGGESTED ORGANIZATION CHART

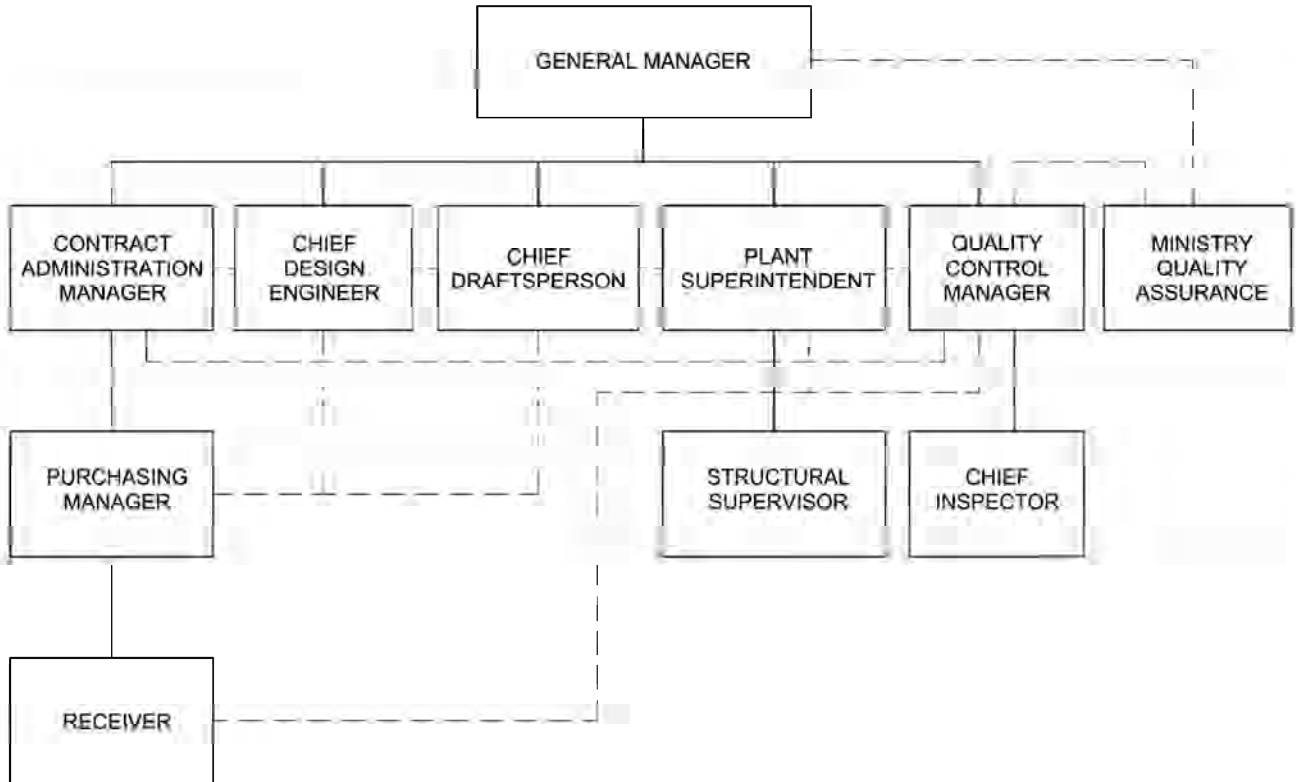

Direct Functional Reporting _____

Quality Control Reporting - - - - -

Signed _____
General Manager

Date: _____

THIS PAGE IS LEFT INTENTIONALLY BLANK

SECTION 416

MANUFACTURE AND INSTALLATION OF POST-TENSIONED CONCRETE MEMBERS

DESCRIPTION

416.01 Scope – This Section covers the manufacture and installation of post-tensioned concrete members.

416.02 General Requirements

416.02.01 The requirements of CAN/CSA-S6-06 and SS 415 shall apply unless specified otherwise herein or in the Contract Documents.

For items not covered in CAN/CSA-S6-06, SS 415 or the Contract Documents, CAN/CSA A23.1, Subsection 6.8, shall apply.

416.02.02 Three weeks before post-tensioning, the Contractor shall submit to the Ministry Representative for review, complete details of the proposed procedure, including jacking sequence and loads, procedure for testing grout cubes, and a list of equipment. This procedure shall be prepared and sealed by a professional engineer registered with the APEGBC.

MATERIALS

416.11 Anchorages – Anchorages tested in an unbonded state shall develop at least 95% of the minimum specified ultimate strength of the prestressing tendons, without exceeding anticipated set and without slippage. Test results or certificates meeting these requirements shall be supplied by the Contractor.

Anchorages shall be able to sustain the loads applied to them without slippage, distortion or other changes that will permit loss of prestress.

The anchorages shall be of such a nature that they will not kink, neck down or otherwise damage the prestressing steel.

416.12 Ducts – The ducts shall be provided with vents at all high points and at the anchorages, so as to facilitate grouting. Drains may be provided at low points. In any case, in cold weather, care shall be taken to prevent water from collecting and freezing in the ducts. The locations of the vents and drains shall be as shown on the drawings.

Cored and external ducts shall be watertight when tested under an internal water pressure of 0.35 MPa.

The vents and drains shall be 13 mm minimum diameter flexible tubes. The connections to the ducts shall be made with metallic structural fasteners.

416.12.01 Internal Tendons – The sheaths for post-tensioning ducts shall be made of galvanized steel or plastic. Galvanizing shall meet the requirements of CAN/CSA G164-M. Plastic sheaths shall meet the

requirements of SS 416.12.02. The sheaths shall be corrugated, and chemically non-reactive with concrete, tendons, or grout. The inside cross-sectional area of the sheaths shall be at least two times the area of the prestressing steel.

Rigid steel sheaths shall have a wall thickness of at least 0.60 mm and shall be capable of bending to an inside radius of 9 m without distress. Semi-rigid steel sheaths shall have a wall thickness of at least 0.25 mm and shall be capable of bending to an inside radius of 3.50 m without distress.

The ducts shall be spliced with telescopic sleeves. The joint lines between the ducts and the sleeves shall be wrapped with tape or heat-shrink material to make the connections mortar-tight.

416.12.02 External Tendons – Unless otherwise specified, sheaths for external post-tensioning shall be made of plastic. Plastic sheaths, including their splices shall be made of high density polyethylene conforming to ASTM Standard D 3350, cell classification 334420C. The polyethylene sheath shall be manufactured in accordance with ASTM Standard D 2239.

Plastic sheaths shall not be used when the radius of curvature of the tendon is less than 10 m. Sheaths and their splices for external post-tensioning shall be smooth, seamless and capable of withstanding a grouting pressure of at least 1 MPa.

416.13 Condition – Tendons, ducts, anchor assemblies and other accessories shall be free of grease, oil and other foreign matter. A light coat of rust will be permissible provided any loose rust is removed and the surface of the steel is not pitted.

416.14 Epoxy – Epoxy applied to match-cast segment ends shall be as specified by AASHTO Standard Specifications for Highway Bridges (2002), Division II, Section 8.13.7.

416.15 Grout – Cement, water and admixtures for grout shall conform to the requirements of CAN/CSA A23.1, Clause 4.2. Unless otherwise specified, grout for post-tensioning shall have a compressive strength of at least 20 MPa at 7 days and 35 MPa at 28 days. The Contractor shall propose a design mix for the grout and submit it for review by the Ministry Representative before grouting may begin.

The Contractor shall supply all materials for the grout.

The grout shall have a maximum water/cement ratio of 0.45. The grout shall consist of a mixture of Type GU (general use) cement, water and an approved admixture to

SECTION 416

control expansion and pumpability. The admixture shall be an aluminum powder base premixed material. Type HE (high early strength) cement may be substituted for Type GU during low temperature periods. The Contractor shall determine the dosage of the admixture by using volume change and bleeding tests conducted before grouting commences. The Contractor shall make test grout cubes and deliver them to a testing agency acceptable to the Ministry.

EQUIPMENT

416.21 Stressing Equipment

416.21.01 Supervision – The Contractor shall provide a supervisor skilled in the use of the system of post-tensioning to be used.

416.21.02 Gauges and Calibration – The tensioning system shall be equipped with gauges that have been calibrated for the specific jacks and controls by an approved testing agency within the last 6 months. The dials of the gauges shall be at least 150 mm in diameter. Before stressing commences, certified calibration curves shall be furnished by the Contractor.

The tensioning system or tensioning devices shall be recalibrated if during the work any gauges give erratic results.

416.22 Grout – The grout shall be mixed in a shear type mixer with sufficient capacity to guarantee a continuous supply of grout to the pump. The accessory equipment to batch all materials shall accurately measure all materials.

The pump shall be a positive-displacement type and shall produce an outlet pressure of at least 1 MPa. The pump shall have seals to prevent introduction of oil, air or other foreign substance into the grout and to prevent loss of grout.

The grouting equipment shall utilize gravity feed to the pump inlet from a hopper attached to and directly over it. The hopper must be kept partially full of grout to prevent air from being drawn into the ducts.

The grouting equipment shall contain a screen having clear openings of 2.5 mm maximum to screen the grout prior to its introduction into the grout pump. A screen opening of 5 mm is satisfactory if a grout with a thixotropic additive is used. This screen shall be readily accessible for inspection and cleaning.

The Contractor shall have on site a pressure gauge with a full-scale of no greater than 2 MPa. The Ministry Representative may request the Contractor to install the gauge in the grout line between the pump outlet and the duct inlets to confirm pumping pressures.

The grouting equipment shall be capable of continuously grouting the largest tendon on the project in 20 minutes.

MANUFACTURE AND INSTALLATION OF POST-TENSIONED CONCRETE MEMBERS

CONSTRUCTION

416.31 Anchorages – The spacing between anchorages shall be sufficient to allow the operation of the stressing jacks to be unimpeded by the adjacent tendons.

The axis of the tendons shall be in line with the anchorages for a minimum of 400 mm.

The load from the anchoring devices shall be effectively distributed to the concrete.

Anchorages shall be rigidly held in position when the concrete in the section is placed. Anchorages shall hold the tensioned tendons without slip of more than 6 mm; otherwise detensioning will be required.

416.32 Ducts – Vents and drains in the ducts shall be mortar-tight, taped as necessary and shall provide means for injection of grout and for sealing. The ends of vents and drains shall be removed 25 mm below the concrete surfaces after grouting has been completed. If drains are used, they shall be vented downward and shall remain open until grouting commences to permit the removal of any water that may be present in the duct.

416.33 Placement and Protection of the Tendons and Other Accessories – The plan and profile location of the ducts shall be as shown on the Drawings. Ducts shall be securely held at intervals of 1000 mm or less to prevent displacement or flotation during the placement of concrete. They shall be placed with a tolerance of ± 6 mm in both the vertical and the horizontal directions. The location of the ducts shall permit the post-tensioning steel to follow the prescribed profiles.

The anchorage assemblies shall be placed so that the bearing surfaces are concentric with and perpendicular to the tendons within $\pm 1^\circ$.

Immediately before concrete is placed, the post-tensioning steel profile and alignment shall be checked and corrected where necessary. The ducts, grout fittings, vents and drains shall be inspected and damage shall be repaired to prevent concrete from leaking into the ducts.

The grout fittings and the ducts shall be adequately protected from collapse and other damage. Grout openings, vents and drains must be securely anchored to prevent displacement during concrete placing operations.

The ends of the ducts shall be covered to prevent the entry of water or debris after the installation in the forms.

The ducts shall be blown out with compressed, oil-free air immediately after the completion of the concrete pour. The compressed air shall be used to the extent necessary to break up and remove any mortar in the ducts before it hardens. The ducts shall be blown out clear of any water or debris again prior to the placing of the tendons.

SECTION 416

Duct ends at match-cast segment ends shall be fitted with gaskets or other sealing devices to prevent infiltration of epoxy during assembly. A uniform pressure of approximately 0.3 MPa shall be applied to the joint during the epoxy curing period. The pressure may be supplied by stressing a cable to a predetermined level, or by other means.

Segmental section joints of 10 mm to 70 mm wide shall be filled with a sand-cement mortar. Joints over 70 mm wide shall be filled with concrete. The strength of the mortar or concrete used in joints shall be at least equal to the parent concrete. The Contractor shall colour the mortar or concrete to match the parent concrete. The Contractor shall submit a trial mix with a proportion of white Portland cement, if necessary, to the Ministry for its review.

All post-tensioning steel shall be installed in the ducts prior to the concreting of the cast-in-place elements.

The concrete shall be vibrated with particular care at each cast-in-place end block (push-through diaphragm) and post-tensioning anchorage location. This will ensure adequate consolidation in the anchorage zones.

The prestressing steel in each tendon shall be pulled immediately after concreting, to ensure that it is free to move and is not bonded by concrete or grout leakage.

416.34 Stressing – The structure shall be stressed only after the concrete has reached its transfer strength as shown on the Drawings. No tendons shall be stressed until authorized by the Ministry Representative.

Tendons shall be stressed from the end as shown on the Drawings.

The supports under the segmental sections shall be able to accommodate horizontal movements caused by the stressing.

The multiple strands composing a tendon in a common duct shall be tensioned simultaneously. Tendons shall be tensioned in sequence as specified in the reviewed procedure. The tendon force at lock-off shall be as shown in the procedure.

Before commencing the stressing operation an initial tensioning force shall be applied to each tendon to equalize stresses and to eliminate slack. This force shall not exceed 10% of maximum jacking force.

After the initial tension forces have been applied, reference points shall be established for each tendon from which elongation by final tensioning forces will be measured.

The specified tensioning force shall be maintained steady in the strands until they are anchored. The sequence of tensioning shall be such that no undue tension stresses occur in the concrete near the ends of the members.

MANUFACTURE AND INSTALLATION OF POST-TENSIONED CONCRETE MEMBERS

The tensioning force shall be determined by the calibrated gauge and by the elongation of the strands. When there is a difference of over 5% between the two means of calculation, the cause of the discrepancy shall be ascertained and corrected.

Tendons shall not be subjected to jacking forces in excess of 85% of their specified ultimate tensile strength. Any tendon subjected to such forces will be rejected.

The required tendon elongation and jacking force shall be computed, based on the required prestressing force and the estimated prestress losses.

The safety of the stressing procedure shall be in accordance with Workers Compensation Act, Occupational Health and Safety Regulation, BC.

Stressing records shall be kept. Stressing records shall clearly identify the tendons that were stressed, the sequence, the final jacking loads, the tendon elongations, the times, the temperatures and the dates. Stressing records shall be signed by the person supervising the stressing and submitted to the Ministry Representative.

416.35 Grouting – The temperature of grout shall be controlled by water temperature. Grout shall not be warmer than 30°C or colder than 5°C at the pump. The grout shall be mixed for a minimum of 2 minutes. The materials shall be charged in this order: water, cement and admixture. The admixture shall be added in accordance with the manufacturer's instructions.

The grout shall be mixed to a uniform consistency of thick cream without lumps or undispersed cement. The grout shall be agitated continuously and shall be recirculated when not injecting from the line.

Water shall not be added to the grout to increase the flowability that was decreased by delayed use of the grout. The grout shall be discarded when flowability has so decreased it cannot be pumped satisfactorily.

The time between the tensioning and grouting of a tendon shall not exceed 4 days.

Cored ducts with concrete walls shall be flushed with clean water to ensure that concrete is thoroughly wetted prior to grout injection. The ducts for external tendons shall be checked for leakage and blockage by flushing with clean water under pressure followed by oil-free compressed air immediately prior to grouting. Metal sheaths for internal ducts shall be flushed to clean out foreign materials, or oil free compressed air shall be used to check for blockages.

All grout and high point vent openings shall be open when grouting starts. Grout shall be allowed to flow from the first vent until any residual flushing water or entrapped air has been removed. The vent shall be capped or otherwise

SECTION 416

closed at that time. The remaining vents shall be closed in sequence in the same manner.

The pumping pressure at the tendon inlets shall be at least 0.7 MPa and shall not exceed 1.5 MPa.

If the pumping pressure exceeds the maximum allowable, grout may be injected at any grouted vent, as long as a one-way flow of grout is maintained. If this procedure is used the vents that are to be used for injection shall be fitted with positive shutoffs.

The grout shall be pumped through the ducts and continuously wasted at the outlet pipes until no visible slugs of water or air are ejected. The efflux rate of the ejected grout shall not be less than the influx rate of the injected grout.

To ensure that the tendons remain filled with grout, the outlets shall be closed and the pressure held for 10 seconds. The grouting ends shall then be plugged. Plugs, caps or valves shall not be removed or opened until the grout has set. Alternatively, the outlets and inlets shall be kept under a 1000 mm head of hydrostatic pressure. The 1000 mm grout head shall be maintained until the grout has hardened.

The grout shall be immediately flushed out of the ducts with water when one-way flow of grout cannot be maintained. Standby water flushing equipment, with its own source of power, shall be available in addition to the grouting equipment. It shall be capable of developing a pressure of 2 MPa, and sufficient capacity to flush out any partially grouted enclosures. After flushing, the ducts shall be blown out with oil-free compressed air and then checked for blockages. The grouting procedure shall be repeated if there are no blockages.

The ducts shall be completely filled with grout. The presence of ungrouted lengths of duct shall be cause for nonacceptance of the members. Members with partially ungrouted duct(s) shall be replaced or repaired to the satisfaction of the Ministry at the contractor's expense.

Great care shall be taken to prevent blockages of the ducts due to grouting of nearby ducts or other causes.

MANUFACTURE AND INSTALLATION OF POST-TENSIONED CONCRETE MEMBERS

All costs for investigations and for remedial measures due to blockages shall be at the Contractor's expense.

The grouting shall not be done when air temperatures are above 32°C or below 5°C, nor when freezing temperatures are predicted within the next 24 hours.

The temperature of the concrete shall be 2°C or higher from the time of grouting until site-cured cubes of grout reach a compressive strength of 6 MPa.

The grouted ducts may be subject to gamma ray radiography inspection. The cost of the inspection will be borne by the Ministry if the inspection indicates that ducts are completely filled with grout. Otherwise, the costs of inspection and the cost of reinspection shall be borne by the Contractor.

416.36 Cropping – The cropping of post-tensioning strand shall be by a cold-cutting procedure. It shall not take place until authorized by the Ministry. Under no circumstances shall heat be applied to post-tensioning strand from cropping or other operations. The cropped strand shall be provided with a minimum concrete cover of 25 mm.

416.37 Anchorage Recesses – The anchorage recesses shall be cleaned and sandblasted after completion of post-tensioning and grouting. The surfaces shall be coated with an epoxy bonding agent conforming to ASTM C 881, Type V, Grade 2. The Class of bonding agent shall be appropriate for the temperature at time of application. The bonding agent shall be applied in accordance with the manufacturer's applications. Wire mesh shall be placed before concreting in recesses larger than 300 mm square.

The Contractor shall fill the recesses flush with adjoining surfaces. All parts of anchorages shall have a minimum cover of 25 mm. All recesses exposed to view shall be filled with concrete coloured to match the parent concrete. If requested, the Contractor shall submit a trial mix with a proportion of white Portland cement to the Ministry Representative for review.

SECTION 418

CONCRETE BRIDGE DECK SEALANTS SILANE SURFACE TREATMENT OF NEW PORTLAND CEMENT CONCRETE

418.01 Scope – This Section describes the treatment of new concrete bridge surfaces with a silane protective solution. The Specification describes surface preparation and application.

418.02 Silane Solution – The silane solution shall be a minimum 40% solution of alkyl trialkoxy silane (isobutyl trimethoxy silane or n-octyl triethoxy silane) dissolved in a maximum of 60% anhydrous alcohol.

418.02.01 Delivery and Storage of Silane Solution – The silane solution shall be delivered to the job site in unopened, sealed containers with original seals intact, also with a manufacturer's label identifying the product (including a batch number). The containers holding silane solution shall be stored in dry, enclosed structures to protect the contents from misuse, weather and excessive heat.

418.02.02 Quality Assurance – Only silane solution from an approved list prepared by the Ministry shall be permitted for use on the job.

Certification shall be required for each batch shipment of silane solution, prior to its use.

418.03 Contractor's Qualification – The applicator shall have a minimum of three years of successful and documented experience in application of liquid water repellents to concrete or masonry substrates, or else the applicator must provide documentation certifying that training approved by the manufacturer and the Ministry for applying silane solution was received.

418.04 Job Site Conditions

418.04.01 Substrate Condition – Prior to silane treatment:

- New concrete shall be cured for a minimum of 28 days.
- All concrete surfaces shall be fully dry.

418.04.02 Weather Limitations – Application of silane solution shall be undertaken only during periods when rain or snow has not occurred during the previous two days and no rain or snow is forecast by the weather office for the next two days.

Application of silane solution shall proceed only when the concrete surface temperature is above 4°C and below 32°C, and windspeed is less than 24 km/hr.

418.05 Surface Preparation – All concrete surfaces prepared for treatment shall be thoroughly cleaned prior to application of the silane solution. The method of cleaning shall be capable of removing loose concrete, curing compounds, laitance, dirt, dust, salt, oil, asphalt or other foreign materials. The cleaning process shall expose

concrete pores and capillaries to readily accommodate silane penetration.

The cleaning process shall not damage the concrete surface, remove or alter the existing surface finish, or expose the coarse aggregate of the concrete. The method of cleaning shall be performed in such a manner as to provide a uniform appearing surface colour.

418.05.01 Pre-Surface Cleaning – If necessary, pre-surface cleaning preparations may include the use of solvent and hand tools to remove materials detrimental to the silane treatment of the concrete surface.

418.05.02 Surface Cleaning – Suitable methods to clean the concrete surface are:

- Sand blasting
- Steel shotblasting
- Hydro blasting
- Steam cleaning
- Water pressure washing using a minimum of 3.5 MPa (500 psi) nozzle pressure.

The cleaning method used shall be capable of cleaning concrete surfaces, as specified.

418.06 Silane Application – Silane application shall proceed only if the condition of the cleaned concrete surface is approved by the Ministry Representative.

418.06.01 Surface Condition – All concrete surfaces shall be fully dry prior to silane solution application. Concrete surfaces previously steam cleaned or water washed must be allowed to dry prior to application of silane solution for:

- Minimum one day during windy or sunny days when air temperatures are over 20°C.
- Minimum two days during calm or cold days when air temperatures are between 4°C to 20°C.

418.06.02 Silane Solution – The silane solution shall be used as supplied by the manufacturer. It shall not be diluted or altered in any way. Water shall not be allowed to contaminate the silane solution.

418.06.03 Application Equipment – The silane solution shall be sprayed on the concrete surface by using low pressure 0.1 MPa – 0.2 MPa (15 – 30 psi) positive displacement airless spray equipment. Suitable equipment is a pressurized garden sprayer or drum mounted pump. Large deck areas over 400 m² shall be sprayed using a spraybar type unit.

All spray equipment shall be fitted with fan spray nozzles and the spray adjusted to a "wet spray" condition (i.e., minimum atomization of silane solution).

i) Cleaning of Application Equipment – All application equipment must be clean and dry prior to use. If equipment is wet, it shall be rinsed with a small amount of methyl hydrate (methanol) prior to commencement of the actual application.

418.06.04 Rate of Application

i) Surfaces Subject to Traffic Wear – Bridge decks and other surfaces subject to traffic wear shall be treated with silane solution at a rate of 0.40 ℓ/m².

ii) Surfaces not Subject to Traffic Wear – Surfaces not subject to traffic wear (parapets, pier caps, sidewalks, etc.) shall be treated with silane solution at a rate of 0.23 ℓ/m².

418.06.05 Method of Application – Silane solution shall be applied at a coverage rate according to this Specification. Horizontal surfaces shall be uniformly sprayed to saturate/flood the surface. Vertical surfaces should be treated from the bottom up and uniformly sprayed to saturate the surface.

If it is not possible to complete the silane treatment in one application, the boundary between the treated and untreated areas shall be clearly marked.

418.06.06 Curing – Following the application, the surface of silane treated concrete shall be cured by mist

spraying with water after:

- 4-6 hrs, during days with temperatures between 25°C – 32°C
- 6-12 hrs, during days with temperatures between 15°C – 25°C
- 12-24 hrs, during days with temperatures between 4°C – 15°C

The traffic may be allowed on silane treated concrete one hour after the water wetting operation.

418.07 Safety and Health Hazards – Personnel exposed to silane solution and methyl hydrate shall wear personal protective equipment such as coveralls, goggles, rubber gloves and proper respirators.

No smoking, open flames, sources of heat or ignition shall be permitted during the construction operation.

Special precautions must be taken during the construction operation to prevent any over spray or spillage of materials on plants and vegetation or into fish-habitat water bodies, (SS 165, Protection of the Environment).

Manufacturer's material safety data and handling instructions shall be followed.

418.08 Measurement and Payment – Payment for the concrete deck sealant will be made at the unit price bid per square metre for the preparation of the concrete surfaces and the supply, application and curing of the deck sealant.

SECTION 419

CONCRETE BRIDGE DECK WATERPROOFING SYSTEM PREFABRICATED MEMBRANE

DESCRIPTION

419.01 Scope – This Section describes the protection of concrete bridge decks with rubberized asphalt prefabricated membrane overlaid with hot mix asphalt pavement. The Section describes materials, surface preparation and application.

NOTE: This Section is not applicable to existing concrete with high levels of chloride contamination. Membrane and pavement overlay shall not be installed on concrete bridge decks contaminated with acid-soluble chloride ion (Cl⁻) in excess of 0.10% by mass of cement.

MATERIALS

419.11 General – The membrane and accessory materials shall be supplied as a package containing:

- a) full-width membrane, self-adhering internally reinforced sheet of rubberized asphalt. Membrane shall have a minimum thickness of 1.6 mm (65 mils) and shall be supplied in rolls in width between 900 mm and 1500 mm (3' to 5').
- b) detailing strip of membrane, self adhering internally reinforced sheet of rubberized asphalt. Membrane shall have thickness between 1.50 and 1.75 mm (60 to 70 mils) and shall be supplied in rolls in width between 200 and 305 mm (8" to 12").
- c) primer, rubberized asphalt dispersed in organic solvent with minimum solids of 45% (by mass), and maximum drying time of one hour.
- d) mastic, single component material, consisting of rubberized asphalt, organic solvent and fillers, supplied in caulking tubes.

419.12 Delivery and Storage – Membrane and accessory materials shall be delivered to the job site in unopened packages and containers with manufacturer's label identifying the product and a batch number.

The packages and containers shall be stored in a dry secured place protected from weather and excessive heat. Specific manufacturer's instructions for storage shall be followed.

419.13 Quality Assurance – Only membranes and materials accessories (supplied as a package) from the Recognized Products list prepared by the Ministry will be permitted for use on the job.

Certification shall be provided for each batch (package) shipment, prior to its use.

CONSTRUCTION

419.31 Applicator's Qualification – The applicator must have a minimum of three years of successful and

documented experience in application of solid membranes to concrete substrates, or else the applicator must provide documentation certifying that training approved by the manufacturer or the Ministry for applying solid membranes has been received.

419.32 Job Site Conditions

419.32.01 Substrate Conditions – Prior to application of membrane, new concrete shall be cured for a minimum of 28 days.

419.32.02 Weather Limitations – Application of primer and installation of membrane and pavement overlay shall be undertaken only during stable weather when precipitation has not occurred during the previous 24 hours and is not imminent, and when the minimum ambient and concrete surface temperature is 5°C and rising.

419.33 Surface Preparation – All concrete surfaces shall be sound, smooth, clean and free from any contamination.

- a) All defects in concrete surfaces, cracks, delamination and spalled areas shall be repaired with a suitable patching material. All patching shall be completely cured.
- b) All protrusions and sharp edges shall be removed by using hand tools or power tools.
- c) New concrete overlays on bridge decks and concrete-filled shear keys between prestressed concrete box stringers shall have smooth finish. Broom finishes are not acceptable.
- d) All loose aggregates, laitance, dust, soil, oil and other debris and contaminations shall be removed from the concrete surface by a combination of the following methods:
 - i) high pressure clean dry air sweeping
 - ii) sand blasting
 - iii) steel shotblasting
 - iv) hydro blasting using a minimum of 3.5 MPa (500 psi) nozzle pressure
 - v) steam cleaning.

The method used shall be capable of removing concrete laitance and cleaning concrete surfaces as specified.

419.34 Priming – All concrete deck surfaces that are to receive membrane must be primed.

419.34.01 Concrete Surfaces – All concrete surfaces shall be fully dry prior to application of primer. Concrete surfaces previously steam cleaned or water washed must be allowed to dry prior to application of primer for:

- minimum 24 hours during windy or sunny days when

SECTION 419

air temperatures are over 20°C.

- minimum 48 hours during calm or cold days when air temperatures are between 5° to 20°C.

419.34.02 Primer Material – Primer shall be used as supplied by the manufacturer. It shall not be diluted or altered in any way.

419.34.03 Primer Application – Primer application shall proceed only if the condition of cleaned and repaired concrete surfaces is approved by the Ministry Representative.

All concrete surfaces to be covered with membrane shall be uniformly treated with primer at the rate of 0.15 to 0.25 ℓ/m² depending on the porosity of the substrate surface.

The primer shall be uniformly applied on substrate surface by roller or brush.

419.34.04 Primer Curing – Only as much surface as will be covered by membrane in the workday shall be primed. Primed concrete surfaces not covered by membrane within the workday must be reprimed immediately prior to membrane installation.

All primed areas must be tack free prior to application of the membrane.

419.35 Membrane Application

419.35.01 Detail Work – Extra attention must be given to all detail work. Detail work shall be performed first, prior to installation of the full-width membrane. The membrane shall be installed as called for on Drawings SP419-01 through SP419-08 and as follows:

i) curb or parapet – inside corners at curbs or parapets shall be covered using a detailing strip of membrane. The uppermost edge of the detailing strip of membrane shall be placed and extended up the face of curb or parapet to 6 mm (1/4") below the finished height of the asphalt pavement overlay. The detailing strip of membrane shall be installed in such a manner to ensure it is smooth and that it adheres strongly to the face of curb or parapet, and bridge deck without any visible defects ("tenting", "fish mouth" or "bubbles"). The first sheet of the full width of membrane shall then be applied as close as possible to the curb or parapet.

ii) bridge deck edge – on bridge decks without curbs or parapets, the full width membrane or detailing strip of membrane shall terminate 6 mm (1/4") from the outer edges of the deck. The membrane shall be heated at the edge of the deck with light flame from a torch or with a hot air gun, followed by pressing the membrane down with a roller.

iii) drains – areas around drains, basins and any other protrusions shall be double covered with membrane. First,

CONCRETE BRIDGE DECK WATERPROOFING SYSTEM PREFABRICATED MEMBRANE

flashing pieces of detailing strip of membrane are applied, followed by the application of the full width membrane. The membrane shall be installed in such a way as not to obstruct openings of drains and basins.

iv) weep holes – do not require detailing strip. The membrane around weep holes shall be heated with light flame from a torch or hot air gun, and pressed down to expose the opening of the hole.

v) joints and cracks – all filled cracks wider than 3 mm (1/8"), and all joints with a gap less than 6 mm (1/4"), shall be covered with a detailing strip of membrane prior to application of a full width membrane. Joints wider than 6 mm (1/4") shall be treated as a standard expansion joint and membrane shall be terminated at expansion joint assembly.

vi) bridge ends – detailing strip of membrane shall be installed over the joint between the existing pavement and the bridge deck. At each end of the bridge deck, a full-width membrane shall extend at least 900 mm (3') over the paved bridge approaches. In the case of new construction, when the existing structure has gravel approaches, the detailing strip of membrane shall be folded over the deck edge and covered with a full width membrane.

419.35.02 Membrane Installation – The full width membrane shall be applied in a longitudinal direction from the low point to the high point so that laps shed water. The area along the lower edge of the deck shall be covered first.

The full width membrane shall be laid flat, avoiding wrinkles and entrapped air. Each succeeding sheet of membrane shall be applied overlapping the side laps a minimum 65 mm (2 1/2") and the end laps a minimum 150 mm (6"). The entire surface of the membrane, especially laps, and all terminations shall then be rolled with sufficient pressure to affect a bond between the membrane and the concrete surface.

419.35.03 Mastic Application – All membrane terminations shall be sealed with a trowelled application of mastic 12 to 25 mm (1/2" to 1") wide and 1.5 to 3.0 mm (1/16" to 1/8") thick. Mastic shall be applied along the edge of the membrane at the face of the curb or parapet, along both sides of the deck joints, around drains and at termination of the membrane on both ends of bridge approaches.

At the end of each working day, or when application is interrupted by a change in construction scheduling, all membrane terminations shall be sealed with the mastic.

419.35.04 Inspection and Repairs – Prior to paving over the membrane, any defective areas of the membrane shall be repaired to the satisfaction of the Ministry Representative, including:

- tears, damaged areas and inadequately lapped seams

SECTION 419

shall be patched;

- fish mouth shall be slit and repaired;
- large blisters shall be punctured and repaired; and
- if water migrates underneath the installed membrane, then the membrane covering the affected area shall be removed and replaced.

419.35.05 Traffic On Membrane – Traffic shall not be permitted on the membrane prior to installation of asphalt overlay with the exception of vehicles and equipment engaged in installing the asphalt overlay. Only vehicles or equipment provided with pneumatic tires or with flat tracks with rubber bonded pads, shall be permitted on the membrane. Any turning or sudden braking on the membrane shall be avoided. Any damage to the membrane resulting from the movement of vehicles or equipment shall be repaired at the Contractor's expense.

419.36 Paving – Asphalt overlay construction shall proceed only when the final condition of the installed waterproofing membrane is accepted by the Ministry Representative.

Prior to commencing asphalt pavement construction, the weight of equipment, including loaded trucks, paver and rollers, and their maximum combined weight must be accepted by the Ministry's responsible Bridge Engineer. Only this accepted equipment and equipment combination shall be permitted on the bridge structure at the time of construction. Asphalt materials, mix design, mix production and hot mix asphalt pavement construction shall meet the requirements of SS 502 and SS 952.

419.36.01 Asphalt Mix and Pavement Design – Asphalt mix shall meet the requirements of SS 502.06 to SS 502.08 for Pavement Class I, Medium Mix and appropriate asphalt binder. The asphalt pavement thickness constructed over the membrane shall be not less than 100 mm and shall be constructed as indicated in SS 502.25.

419.36.02 Placing The Asphalt Mix – In addition to standard paving practice:

- i) no paving shall proceed over wet membrane;
- ii) no primer shall contaminate membrane surface;
- iii) paving operation shall commence as soon as possible after the waterproofing membrane is installed;
- iv) paving shall proceed in the direction of the end laps in the membrane (i.e., from overlap to underlap);
- v) the Contractor shall take due precautions to avoid damage to the waterproofing membrane during the paving operations by the paver and hauling trucks;
- vi) the paver shall move at a constant speed avoiding any unnecessary stopping;

CONCRETE BRIDGE DECK WATERPROOFING SYSTEM PREFABRICATED MEMBRANE

vii) hauling trucks shall maintain a steady supply of asphalt mix to the paver;

viii) excessive accumulation of asphalt mix in the paver hopper and auger shall be avoided;

ix) unloading of the asphalt mix from the hauling trucks onto the membrane surface will not be permitted;

x) paver screed burners shall be set in such a way as to avoid any damage to the membrane from excessive heat;

xi) the path in front of the screed side end plate must be kept continuously free from spilled asphalt mix. The bottom of the side end plate shall slide freely, otherwise the entrapped asphalt mix could damage the underlying membrane;

xii) screed adjustments during paving shall be made in such a way as to achieve a uniform thickness of mat, surface texture, smoothness and designed pavement geometrics;

xiii) the bridge deck joints, drains and other openings (except weep holes) shall be protected to avoid intrusion of asphalt during the paving operation; and

xiv) during a "one lane at a time" construction method, as on bridges partially open to traffic, the constructed pavement mat shall terminate not less than 100 mm (4") from the edge of installed membrane in order to provide a sufficient area for lapping of the next sheet of membrane.

419.36.03 Compaction – In addition to standard compacting practice:

i) drum vibration mode must not be used during compaction.

ii) steel drum shall run as close as possible to the curb or parapet.

iii) compaction along the expansion joints or concrete dams shall be performed transversely.

iv) sudden stops or sharp turns by rollers shall be avoided.

419.36.04 Hand Work – Placing of asphalt mix in areas inaccessible to large paving equipment shall be done by hand or with smaller equipment.

419.37 Protection Of The Environment – The Contractor shall comply with SS 165, appropriate environmental requirements of Fisheries and Oceans Canada, the Ministry of Environment, and any related municipal regulations.

Special precautions shall be taken during the construction operation to prevent spillage of materials into water bodies.

419.38 Safety and Health Hazards – Materials used in the construction of membrane and asphalt pavement overlay are flammable, toxic and hot. Personnel exposed to these materials and operations shall wear all appropriate

SECTION 419

personal protective equipment such as boots, coveralls, goggles, rubber gloves and proper respirators as specified by Workers Compensation Board. Manufacturer's material, data and handling instructions shall be followed.

MEASUREMENT

419.81 General – Rubberized asphalt membrane will be measured in SQUARE METRES installed.

Hot mix asphalt pavement will be measured in TONNES.

CONCRETE BRIDGE DECK WATERPROOFING SYSTEM PREFABRICATED MEMBRANE

PAYMENT

419.91 General – Payment for the MEMBRANE installation will be made at the Contract Unit Price bid per square metre. The Unit Price shall include everything done and furnished for the full completion of the waterproofing membrane installation.

Payment for the HOT MIX ASPHALT PAVEMENT OVERLAY will be made at the contract Unit Price bid per tonne.

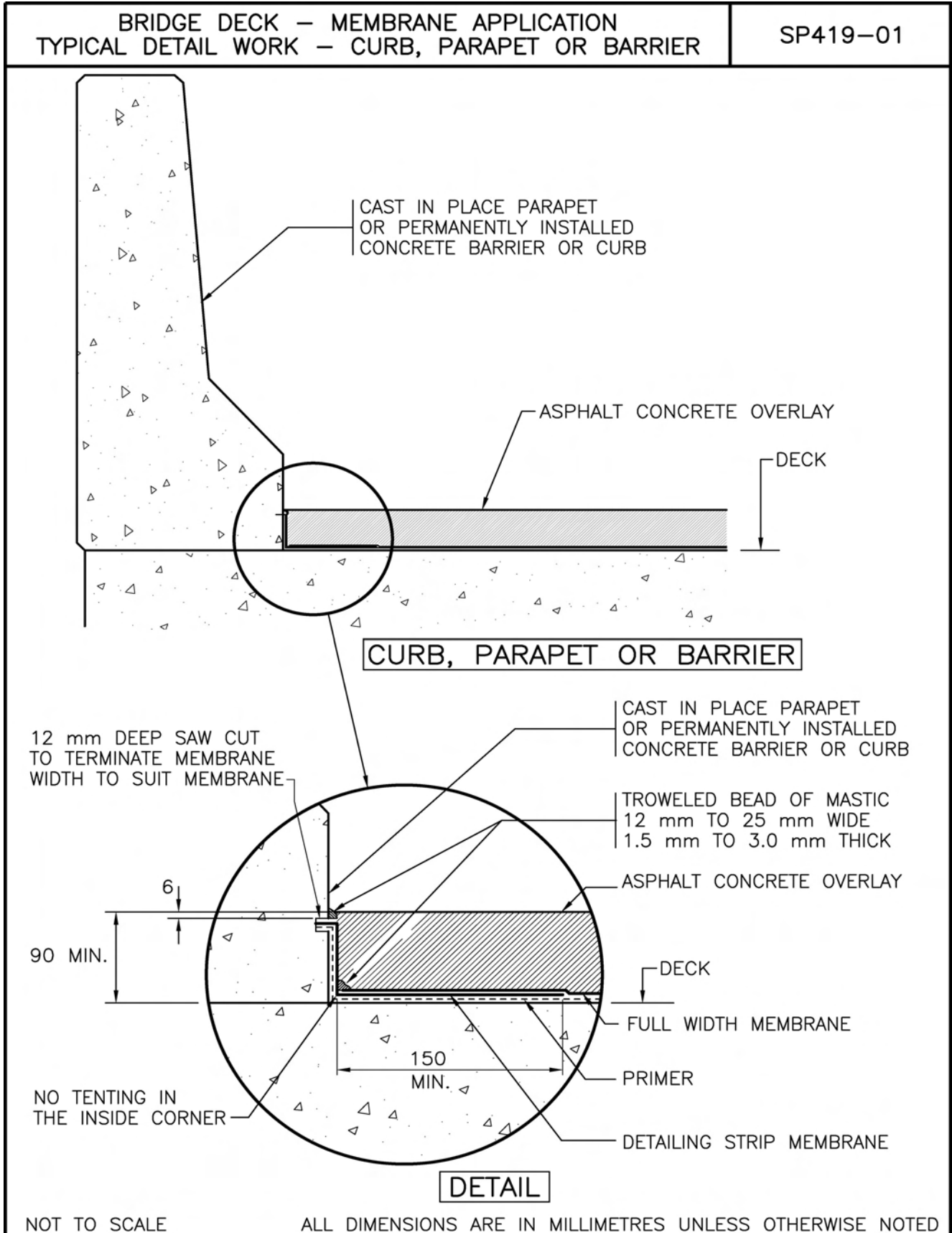

BRIDGE DECK – MEMBRANE APPLICATION
TYPICAL DETAIL WORK – BRIDGE DECK EDGE

SP419-02

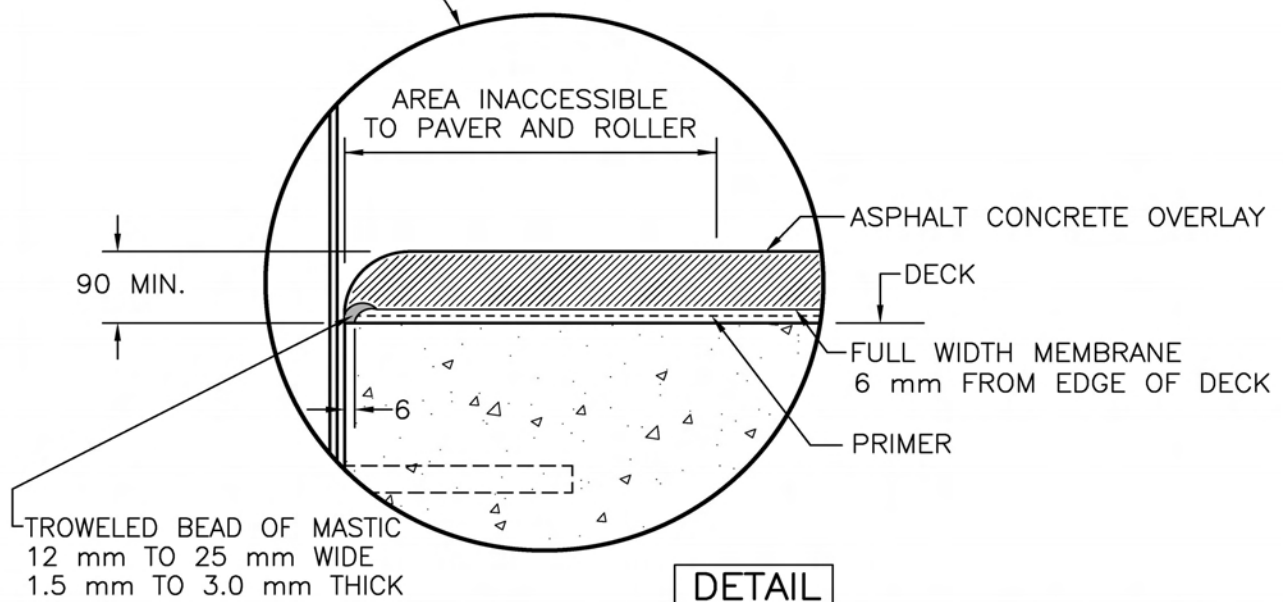
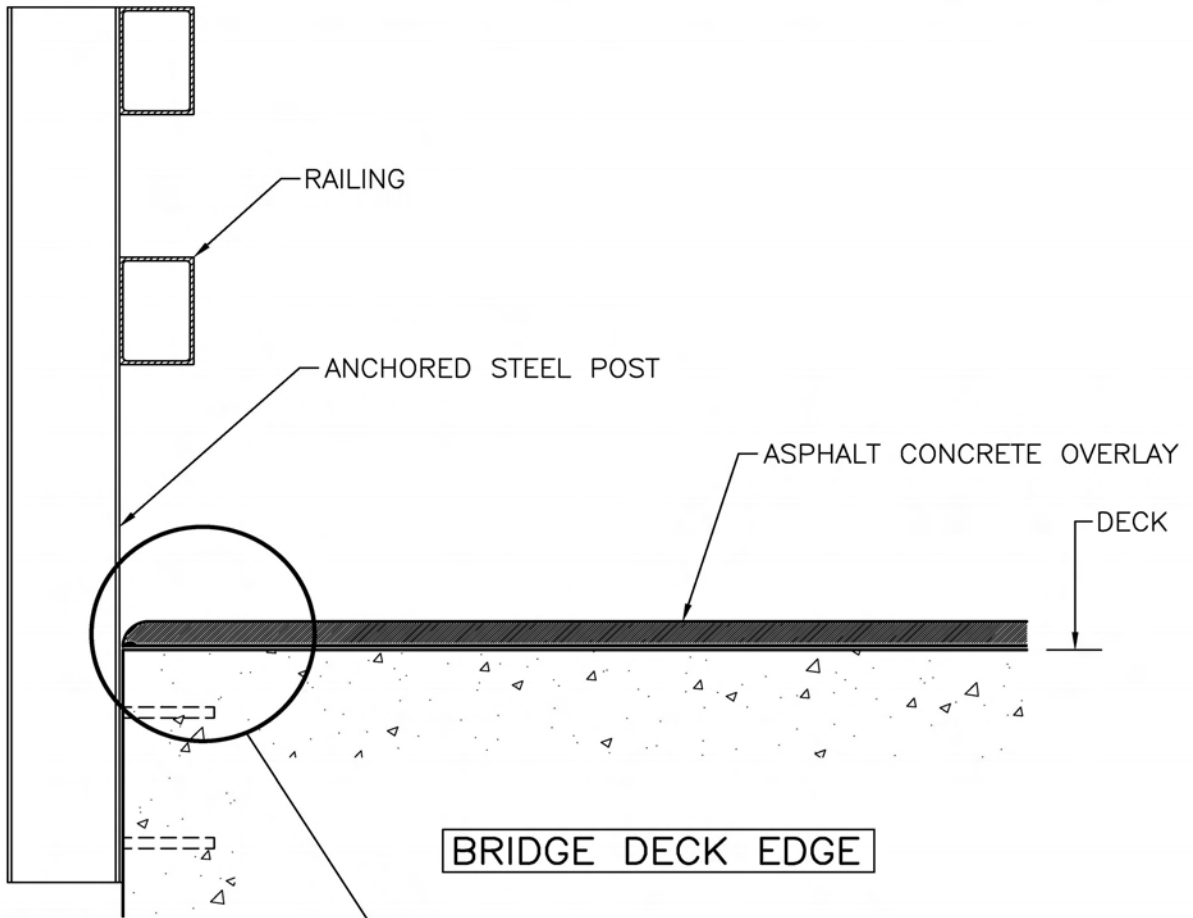

NOT TO SCALE

ALL DIMENSIONS ARE IN MILLIMETRES UNLESS OTHERWISE NOTED

BRIDGE DECK – MEMBRANE APPLICATION
TYPICAL DETAIL WORK – DRAIN AND WEEP HOLE

SP419–03

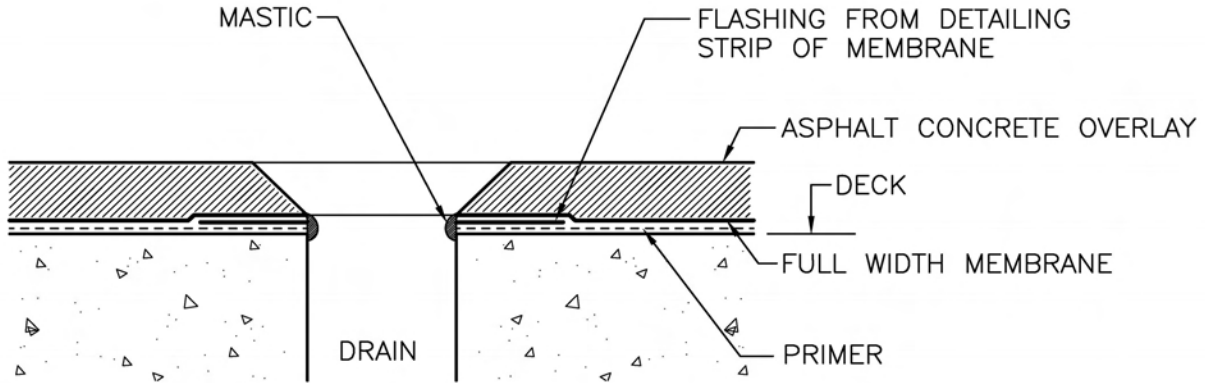

DRAIN

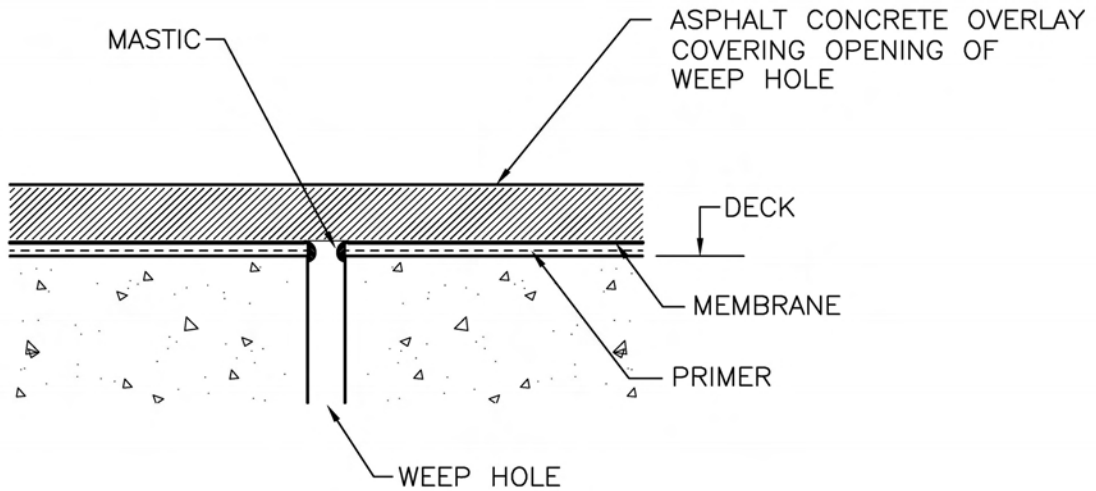

WEEP HOLE

NOT TO SCALE

ALL DIMENSIONS ARE IN MILLIMETRES UNLESS OTHERWISE NOTED

BRIDGE DECK – MEMBRANE APPLICATION
TYPICAL DETAIL WORK – JOINT AND CRACKS

SP419-04

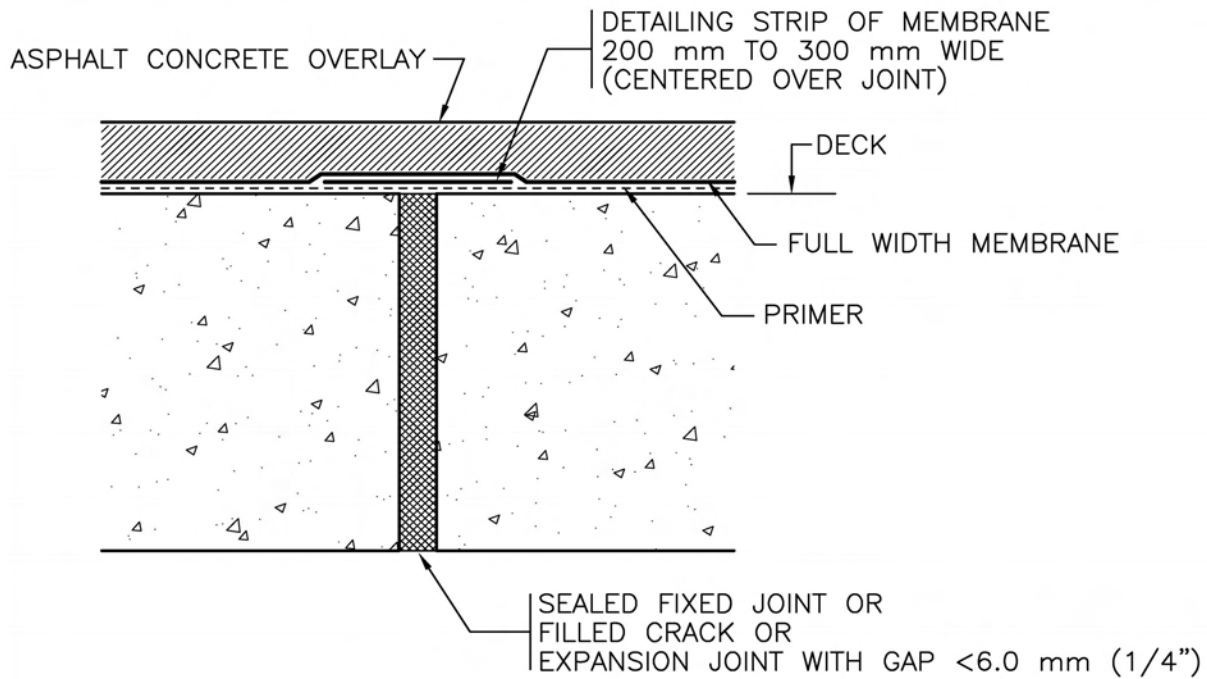

FIXED JOINT OR CRACK

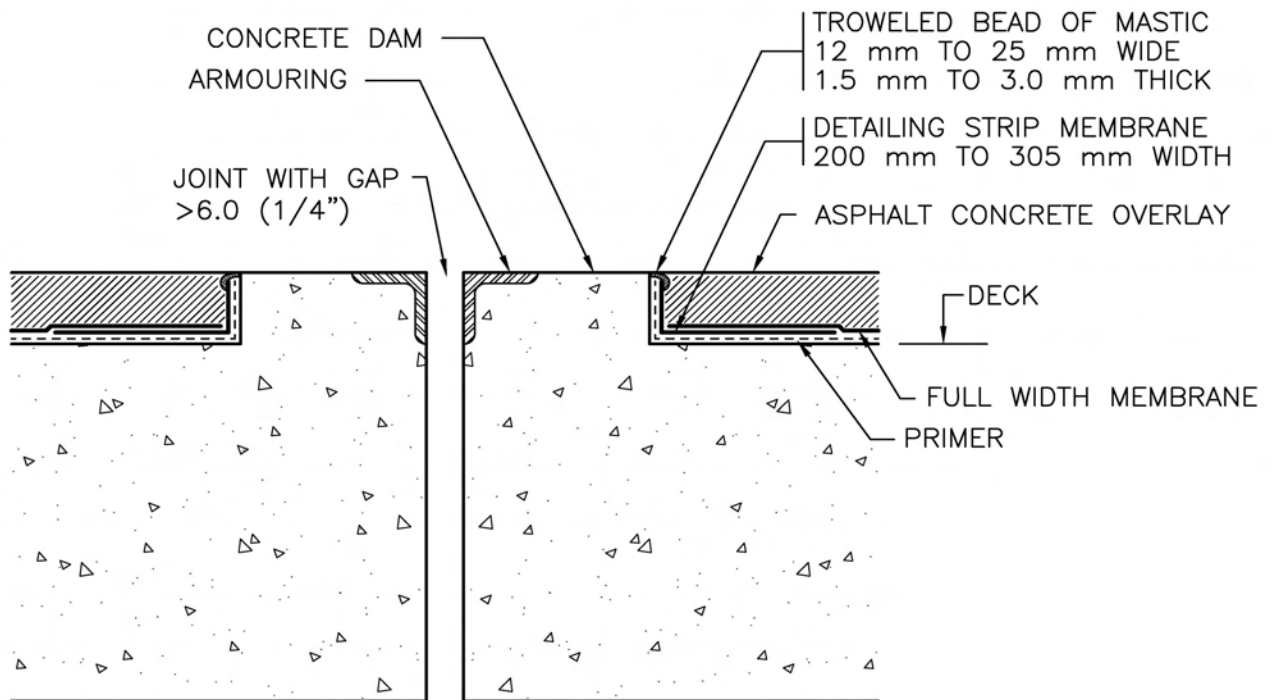

EXPANSION JOINT

NOT TO SCALE

ALL DIMENSIONS ARE IN MILLIMETRES UNLESS OTHERWISE NOTED

BRIDGE DECK – MEMBRANE APPLICATION TYPICAL DETAIL WORK – BRIDGE END	SP419–05
--	----------

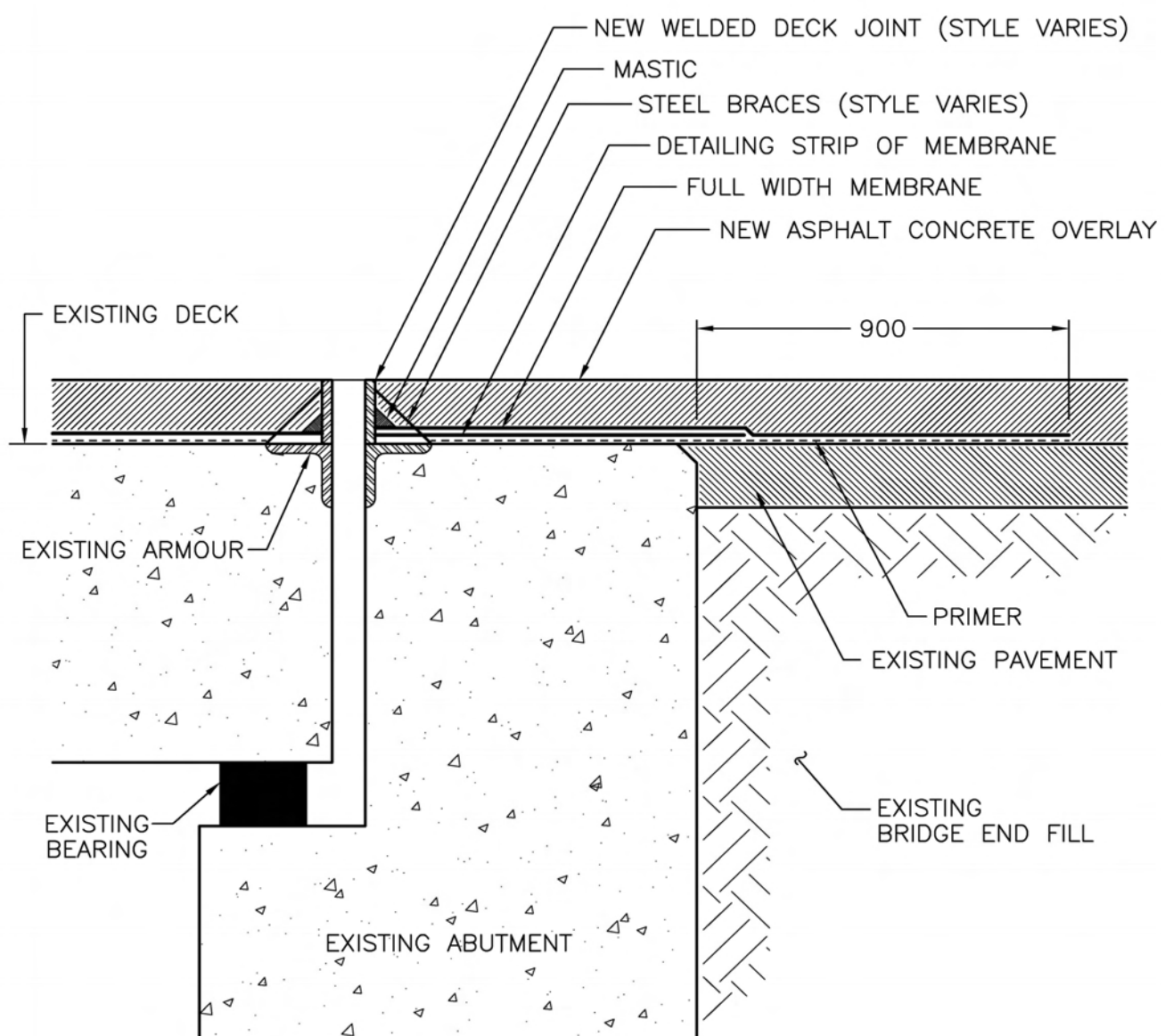

BRIDGE END

(WITH EXPANSION JOINT AND EXISTING PAVED APPROACH)

NOT TO SCALE

ALL DIMENSIONS ARE IN MILLIMETRES UNLESS OTHERWISE NOTED

BRIDGE DECK – MEMBRANE APPLICATION
TYPICAL DETAIL WORK – BRIDGE END

SP419–06

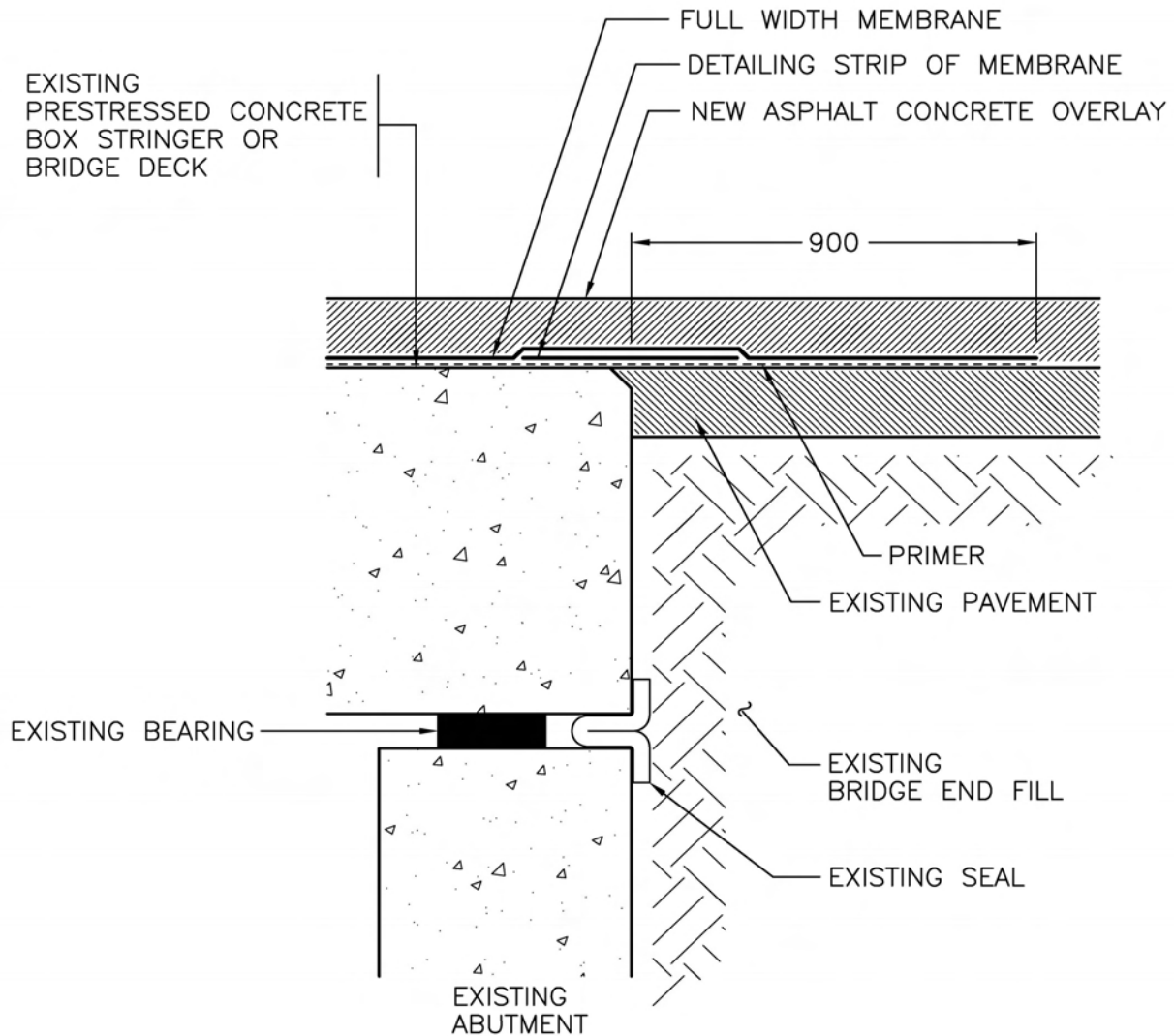

BRIDGE END

(EXISTING PAVED APPROACH WITHOUT EXPANSION JOINT)

NOT TO SCALE

ALL DIMENSIONS ARE IN MILLIMETRES UNLESS OTHERWISE NOTED

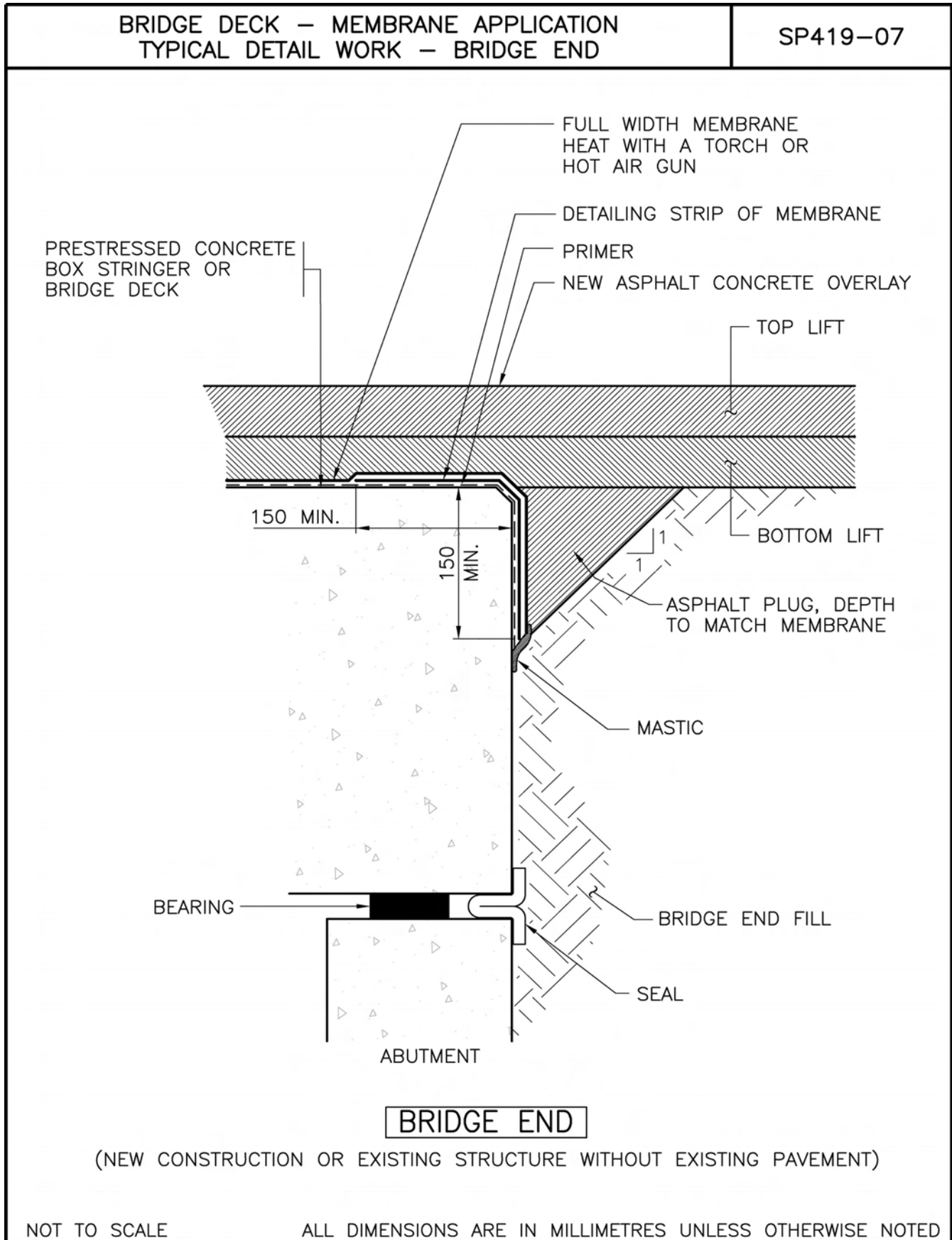

BRIDGE DECK – MEMBRANE APPLICATION
TYPICAL DETAIL WORK – BRIDGE END

SP419-08

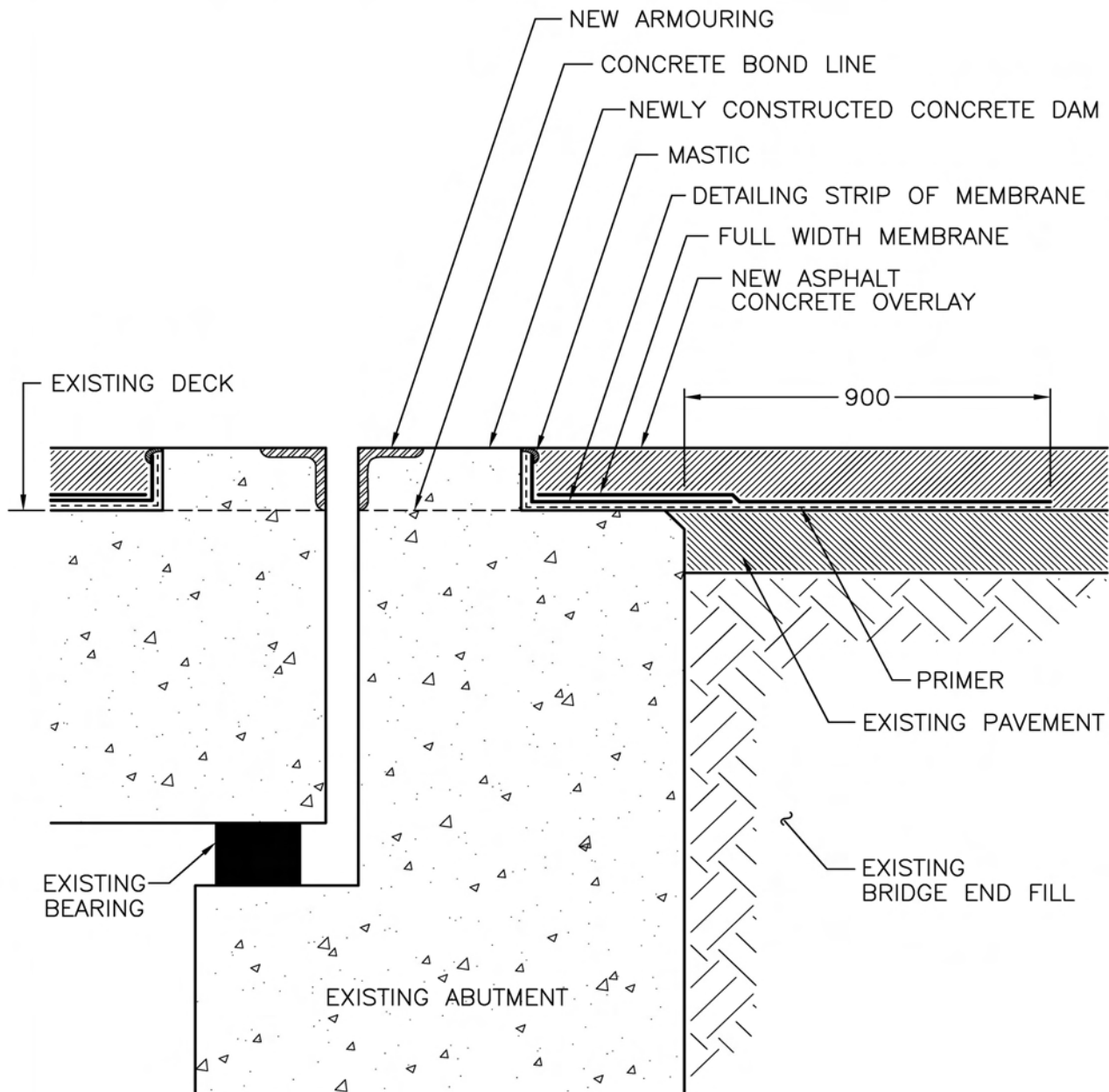

BRIDGE END

(EXISTING PAVED APPROACH WITH EXPANSION JOINT)

NOT TO SCALE

ALL DIMENSIONS ARE IN MILLIMETRES UNLESS OTHERWISE NOTED

SECTION 421

STRUCTURAL STEELWORK

DESCRIPTION

421.01 Scope – This Section covers the supply, fabrication, erection and quality control program of all major structural steel elements.

In general, all shop connections shall be welded, and all field connections high-strength bolted.

Except as otherwise specified herein, steelwork shall be fabricated and erected in accordance with the AASHTO Standard Specifications for Highway Bridges (17th Edition – 2002 including all subsequent interim revisions and updates), Division II, Section 11. Welding and associated work shall be in accordance with the current edition of CAN/CSA W59 – Welded Steel Construction. Fracture control requirements, welding requirements for fracture critical members and welding requirements for primary tension members shall be in accordance with CAN/CSA-S6-06.

421.02 Prefabrication Meeting – The Ministry will convene a prefabrication meeting with the Contractor to review issues such as but not limited to, procedures on quality control, welding procedures, procedures for non-destructive testing, mill certificates and heat numbers, splices, coatings, updated schedule for fabrication, and to confirm the Ministry's requirements.

421.03 Alternative Details – All details shall, in general, conform to those shown on the Drawings. Any proposed variation shall be submitted to the Ministry Representative in writing, with the reason for the variation, and any cost saving or extra cost. The Ministry may require the submission of Drawings prepared and sealed by a professional engineer registered with the Association of Professional Engineers and Geoscientists of British Columbia (APEGBC).

If, in the opinion of the Ministry, the variation represents a clear improvement, it may be accepted without any price adjustment.

If the variation results in a product of equivalent quality, it may be accepted at the discretion of the Ministry. In this case any saving in cost to the Contractor (as determined by the Ministry) shall be passed on as a credit to the Ministry.

421.04 Working Drawings – Working drawings shall consist of the following:

- Shop drawings
- Transportation details and
- Erection drawings

Transportation details and erection drawings shall be prepared and sealed by a professional engineer registered

with the Association of Professional Engineers and Geoscientists of British Columbia (APEGBC).

When the Contractor is responsible for the design of items that are detailed on the shop drawings, the shop drawings shall be prepared and sealed by a professional engineer registered with the Association of Professional Engineers and Geoscientists of British Columbia (APEGBC).

Working drawings shall be in the same system of units as the design drawings.

Working drawings shall be on D size sheets approximately 560 mm (22") by 865 mm (34"), (one drawing per sheet). Lettering for notes and dimensions shall be at least 2.5 mm and 4 mm for headings. Drawings shall be legible when half-sized or microfilmed.

421.04.01 Shop Drawings – Shop drawings shall show all information and details needed for the fabrication of the members including, but not limited to, such items as member shapes and dimensions, connection details, material and product standards, mark numbers and general arrangement of member locations, details of attachments, fastener details, weld details, mass of members, special tolerances, special handling instructions, coating details, lifting details and lifting locations.

421.04.02 Transportation Details – Transportation details shall include such items as:

- Description of hauling and handling equipment
- Weight of members
- Length and height of loads
- Location and method of member support
- Details for handling, storing, and loading of members.

421.04.03 Erection Drawings – Erection drawings shall show in detail the method of erection including, but not limited to, the following:

- Erection procedures
- Procedures for off loading of members upon delivery
- Details for temporary storage and support of members on site prior to erection
- Equipment to be used
- Layout or general arrangement drawing showing the layout of the members, equipment positioning, and access roads
- Crane make, model, and capacity charts, boom length(s), crane placement, and access for transporting of members to crane(s)

- Radii and loads for crane lifts
- Rigging details
- Mass of members , rigging and special installation equipment
- Details for installation and removal of all falsework, temporary supports, temporary bearings, bracing, guys, dead-men, and lifting devices
- Attachments to the bridge members and bridge structure for temporary support and special launching equipment
- Detailed description of sequence of operations
- Details for special installation equipment such as a launching truss, launching nose, head frames, spreader beams and rollers
- Details for installation of members onto the permanent bearings
- Traffic control plan for roadway and rail traffic
- Details for protection of existing utilities affected by the erection procedures
- Layout and details of fall protection and their sequence of installation.

The Contractor shall be responsible for the lateral stability of members and shall design and provide bracing as necessary until completion of the Work.

The erection drawings shall be complete in detail for all anticipated phases and conditions during erection and during the temporary support of members. The Contractor shall submit calculations , upon request, to the Ministry Representative that demonstrate that specified factored demand/capacity ratios or allowable stresses are not exceeded in members, falsework, temporary bracing and temporary supports and that member capacities and final geometry will be correct. The calculations shall be sealed by the professional engineer that sealed the erection drawings.

Falsework, temporary supports and temporary bracing shall meet the requirements of CSA Standard S269.1 – 1975, “Falsework for Construction Purposes” and shall also meet all the requirements for falsework given in Clauses 20.17 to 20.26 inclusive of the WCB Occupational Health and Safety Regulation.

A professional engineer registered with APEGBC shall be responsible for any field designs and any changes made to the erection procedures. Field designs and changes to the erection procedures must be documented and sealed by the responsible professional engineer and must be available at the Site prior to the affected erection work being carried out.

Immediately before placement of loading on falsework, the Contractor must ensure that the falsework is inspected

and a sealed engineering certificate is issued by a professional engineer registered with APEGBC which:

- Indicates the specific areas inspected and
- Certifies that the falsework has been erected in accordance with the latest approved erection drawings and supplementary instructions.

421.04.04 Submittals – The Contractor shall submit to the Ministry Representative three sets of all working drawings. These drawings shall be submitted at least fourteen days prior to the fabrication of the work. Any work done or materials ordered prior to the review of the working drawings shall be at the Contractor's risk. The Ministry will review the drawings for general compliance with the contract requirements.

If modifications to the drawings are required, the Ministry Representative will return one set of drawings, marked up, to the Contractor. The Contractor shall re-submit three sets of the revised drawings to the Ministry Representative.

If no exceptions are taken to the drawings, the Ministry Representative will return one set of reviewed drawings to the Contractor. The Contractor shall forward an additional four sets of the reviewed drawings to the Ministry Representative.

Shop drawings will not be reviewed without the transportation details and erection drawings applicable to the members in question.

Erection will not be allowed to proceed without the Ministry Representative’s review of the method proposed.

Review of working drawings shall not relieve the Contractor of responsibility for carrying out the work in accordance with the contract documents.

421.05 Quality Control – The Contractor shall implement a quality control program to meet the Contract requirements. The quality control plan shall be made available to the Ministry Representative for review.

421.06 Quality Assurance – The Ministry will implement a quality assurance program by auditing the Contractor's quality control program and by inspection at its discretion.

The Contractor shall notify the Ministry Representative at least 14 days before fabrication has commenced. The Contractor shall allow the Ministry's representatives access to all parts of the work, and shall supply such information and assistance as is required. The Contractor shall provide samples of any materials requested by the Ministry. Inspection by the Ministry shall not relieve the Contractor from obligation to perform the work in accordance with the contract.

At its discretion and expense, the Ministry will test any weld by non-destructive testing methods, in accordance with CSA W59. Generally, fillet welds will be tested by

SECTION 421

STRUCTURAL STEELWORK

the dry powder magnetic particle method and butt joints by radiography, or by any other method of testing the Ministry deems necessary, such as ultrasonic and phased array ultrasonic testing methods.

The Ministry will attempt to schedule non-destructive testing operations so as not to interfere with the progress of the work.

The extent of non-destructive testing will usually be as follows:

- | | |
|----------------------------------|------|
| • Butt <u>Joints</u> | 100% |
| • Flange/web fillet welds | 100% |
| • Flange/stiffener fillet welds | 100% |
| • Web/stiffener fillet welds | 25% |
| • Bracing/stiffener fillet welds | 25% |

The inspection of welds shall be carried out as soon as possible after the completion of welding, with the exception that restrained joints shall be inspected in accordance with the requirements of CSA W59 Clause 12. The Contractor shall provide reasonable notice to the Ministry Representative/Inspector regarding requirement for inspection of welds.

The Contractor shall be prepared to move and support the pieces being inspected. In general, inspection shall be done on the flat and a minimum of 1.25 m of headroom shall be available.

The Contractor shall bear the cost of re-inspection of welds after defects are repaired.

The Ministry will inspect bolted connections in accordance with the AASHTO Specifications for Highway Bridges (17th Edition – 2002 including all subsequent interim revisions and updates), Division II, Section 11.

The Ministry Representative shall be notified of any defects found in the work. In general, no repair shall be made until agreed to by the Ministry. In the case of minor corrections, as described by CAN/CSA S6-06 Section 10.23.5.4, approval to proceed may be given either verbally by the Ministry's Inspector, or in advance provided that written repair procedures are submitted for Ministry acceptance prior to the work commencing. In such cases as repair of cracks, or repairs as described by CAN/CSA S6-06 Section 10.23.5.5, or a revised design to compensate for deficiencies, the means of correction shall be prepared and sealed by a professional engineer registered with the Association of Professional Engineers and Geoscientists of BC (APEGBC). It shall be submitted in writing, with adequate sketches, to the Ministry for review.

Each main member shall be audited by a Ministry quality assurance representative before it is shipped from the shop. This audit shall not relieve the Contractor of responsibility for subsequent damage or for defects which

become apparent before the work is finally accepted by the Ministry.

421.07 Quality and Details of Welds – The quality and details of welds shall be in accordance with CSA W59.

421.08 Design Specifications – CAN/CSA-S6-06 shall be used in the design of alternative details and calculating the effect of stresses incurred in fabrication and erection.

No increase in allowable stresses due to vertical loads shall be used for erection conditions.

MATERIALS

421.11 Materials

421.11.01 Structural Steel – Steel shall conform to the requirements of CAN/CSA-G40.20/G40.21-M, and shall be of the grades called for on the Drawings. Plates provided from coils shall not be used. Prior to fabrication, the Contractor shall supply to the Ministry the manufacturer's mill certificates giving details of all chemical and physical properties of steel to be used in the work.

Chemical composition of steel to be galvanized shall be in accordance with SS 421.42.

Steel shall be supplied free of surface defects and internal discontinuities, with due regard for the end use of the steel in the work.

Edges of all plates will be subject to inspection by the Ministry. Any discontinuities will be examined and may be accepted.

The Ministry shall be supplied with a record of all observed discontinuities and repair methods.

Repairs to defective plates shall not proceed until review of the proposed repair method by the Ministry.

421.11.02 Welding Consumables – All electrodes shall match the base metal specified in accordance with CSA W59, Table 12.1. The deposited weld metal shall provide strength, ductility, impact toughness and corrosion resistance equivalent to the base metal.

Welding consumables for all processes shall be certified by the Canadian Welding Bureau (CWB) as complying with the requirements of CSA W48.01.

421.11.03 High-Strength Bolts – Unless otherwise specified on the Drawings, high-strength bolts, nuts and washers shall conform to the requirements of ASTM A 325, and as follows:

- a) for painted steelwork, Type 1, hot-dip galvanized to the requirements of CAN/CSA-G164-M.
- b) or unpainted weathering steel, Type 3.
- c) for painted weathering steel, Type 3 bolts will be acceptable provided that they are painted after installation in accordance with the field painting specifications.

421.11.04 Shear Connector Studs – Shear connector studs shall conform to the requirements of ASTM A 108, Grades 1015, 1018 or 1020.

421.12 Material Storage and Care

421.12.01 Steel – Structural material, either plain or fabricated, shall be stored above the ground in an upright and shored position upon platforms, skids, or other supports. It shall be kept free from dirt and other foreign matter, and shall be protected as far as practical from corrosion. Long members shall be supported on skids placed near enough together to prevent overstress from deflection.

Prior to fabrication, all steel shall be marked for identification by heat number and specification by a marking system approved by the Ministry.

421.12.02 Welding Consumables – Electrodes and fluxes shall be stored and kept in condition as required by CSA W59, Section 5.2.

Gas for welding shall be stored in marked steel bottles and shall not be subjected to temperatures in excess of 50°C or temperatures of less than 0°C.

421.13 Fabrication – Prior to fabrication, the welders and welding operator's qualifications, shop drawings, welding procedures, mill certificates and welding consumable certificates shall be submitted for the Ministry's review.

No fabrication, welding or coating of steelwork shall commence until permission to do so has been received from the Ministry.

421.14 Ministry's Plant Office – The Contractor shall provide in the fabrication plant or nearby a suitable lock-up office for the sole use of the Ministry throughout the period of fabrication.

The office shall be at least 2.5 m x 3 m and shall be weathertight and reasonably soundproof, provided with ample window area and ventilation, furnished with a 0.75 m x 1.2 m desk, a 1 m x 2 m drafting table, a two-drawer filing cabinet, two chairs, a drafting stool and 3 m of shelves, and equipped with a telephone, which shall be operational throughout the period of fabrication. All long distance telephone calls will be paid for by the Ministry.

The Contractor shall clean, heat and light the office throughout the period of fabrication.

EQUIPMENT

421.21 Qualifications and Equipment

421.21.01 Contractor – The Contractor shall produce evidence that the plant is currently fully approved by the CWB to the requirements of CSA W47.1, Division 1 or Division 2 prior to beginning work.

The Fabricator shall also produce evidence of three years of satisfactory experience in the fabrication of bridge

structural steelwork.

The Contractor shall employ or retain a registered professional engineer experienced in steel bridge fabrication, to provide guidance throughout the work.

A qualified welding supervisor shall be employed on each shift where welding is done on the work.

Prior to fabrication, the Contractor shall submit to the Ministry the names of the welding engineer, the engineer experienced in steel bridge fabrication, and the welding supervisors who are to be employed on the work.

421.21.02 Welders and Welding Operators – The Contractor shall produce evidence that all welders and welding operators to be employed on the work are currently qualified by the CWB at the time of fabrication in the processes in which they are to be employed on the work.

The Contractor shall also produce evidence relative to each welder and welding operator, that they have been executing satisfactory welding in the required processes within the six-month period previous to the award of this contract.

421.21.03 Welding Equipment – All equipment to be used in the work shall be in good working order and shall be subject to the inspection of the Ministry.

For any arrangement of automatic welding, the Ministry may require that a preliminary test run of the equipment be made, without welding, over the length of the joint, to prove that the disposition of the equipment and the method and accuracy of travel are satisfactory.

421.22 Welding Procedures – The Fabricator shall submit copies of the proposed welding procedures for review by the Ministry. Gas metal arc welding shall not be used. Where the submerged arc or flux cored arc process is to be used, the Ministry may order that each welder and welding operator make a weld specimen not less than 1 m in length for fillet welds and 150 mm in length for butt joints. Steel of the same specifications and thickness as that to be used in the work shall be used in the specimen welds.

No welding shall be done on the work until the welders' and welding operators' qualifications are established to the satisfaction of the Ministry.

Welding procedures shall be accompanied by documentary proof that they have been qualified previously by the CWB at the plant where the work is to be carried out.

The procedures shall include the following information: joint type, welding process, welding position, base metal specification, welding consumable specification and size, preheat requirements, amperage and voltage requirements, speed, polarity, and welding equipment, including a description of travel for automatic welding. Additional

information, as described in CSA W47.1-03, Appendix C, shall also be included in the procedures.

421.23 Butt Joints – Except as called for on the Drawings, or as reviewed and approved by the Ministry's design engineer, butt joints will not be permitted. Approval must be given prior to fabrication.

The Fabricator may submit an alternative butt joint design, to that shown on the Drawings, or propose a butt joint design if one is not shown on the Drawings, provided that all such designs have been approved by the CWB. Location and details of all butt joints shall be explicitly shown on the shop drawings.

421.24 Assembly and Welding Sequences – If requested by the Ministry, the Contractor shall supply full details of the proposed assembly and welding sequence of any particular weldment.

CONSTRUCTION

421.31 Preparation of Material

421.31.01 Straightening Material – Prior to being used in fabrication, all structural steel shall be straight and free from kinks or bends. The flatness tolerance of plate in excess of 900 mm wide shall be in accordance with the tolerances of the finished product as specified in CSA W59. If straightening is necessary, it shall be done by methods that will not injure the metal. The steel shall not be heated unless permission is given by the Ministry.

In no case shall the temperature of the steel exceed 620°C. After straightening, the surfaces of the metal shall be carefully inspected for evidence of fracture and if necessary, the material shall be replaced or repaired to the satisfaction of the Ministry. Sharp kinks and bends will be cause for rejection of the steel.

421.31.02 Camber – Girders shall be cambered as shown on the Drawings.

421.31.03 Edge Preparation – Steel may be cut to size by sawing, shearing, plasma cutting or flame cutting. All steel before cutting shall be marked by a method agreed to by the Ministry so that its specification may be immediately identified.

All cut edges shall be smooth and regular, free from fins, cracks, tears and notches. Freehand cutting shall be done only where approved by the Ministry. Roughness of cut surfaces shall not exceed the U. S. Standards Institute B46.1 value of 1000. Roughness exceeding this value shall be removed by machining or grinding. Occasional gouges will be tolerated only at the discretion of the Ministry Representative and shall be repaired as instructed.

Sheared edges of plates more than 16 mm in thickness shall be planed to a depth of 6 mm.

Re-entrant flame cuts shall be filleted to a radius of not less than 20 mm.

All exposed sharp corners of members, which are to be painted, shall be ground to a minimum radius of 1.6 mm.

All corners of oxygen-cut edges of main stress-carrying members, except unpainted bearing stiffeners and girder webs, shall be ground to a minimum radius of 1.6 mm.

Special attention shall be given to the cutting of flange plates. All flange plates prepared by flame cutting shall be preheated in accordance with SS 421.34.

The Fabricator will carry out Brinell hardness testing of the edges of flange plates on fracture critical members. The Brinell hardness of the edges of flange plates on fracture critical members shall not exceed 220. If greater hardness is measured, the edges shall be ground by the Fabricator to remove the hard layer. The Ministry may conduct Quality Assurance testing of Brinell hardness once the flanges have been prepared to meet the hardness requirements. The Contractor shall bear all costs for reinspection and retesting.

Surfaces to be welded shall be free from loose scale, slag, rust, grease, moisture or other material that will prevent proper welding. Mill scale that withstands vigorous wire brushing, a light film of drying oil or a thin rust inhibitive coating may remain except that all mill scale shall be removed from the surfaces on which flange-to-web welds are to be made. Surfaces within 55 mm of any weld location shall be free from any paint or other material that would prevent proper welding or produce objectionable fumes while welding.

Edges of material thicker than specified in the following list shall be trimmed if and as required to produce a satisfactory welding edge wherever a weld along the edge is to carry calculated stress:

- a) Sheared edges of material thicker than 12 mm;
- b) Rolled edges of plates (other than Universal Mill Plates) thicker than 10 mm;
- c) Toes of angles or rolled shapes (other than wide flange sections) thicker than 16 mm;
- d) Universal Mill Plates or edges of flanges of wide flange section thicker than 25 mm.

421.31.04 Direction of Rolling – Steel plates for main members and splice plates for flanges and main tension members shall be cut and fabricated so that the direction of rolling is parallel to the direction of the primary stresses.

421.31.05 Bolt Holes – Standard holes for high tensile bolts shall be either punched, sub-punched and reamed, or drilled, and shall be of a nominal diameter not more than 2 mm in excess of the nominal bolt diameter, except that the following bolt/hole combinations will be permitted:

- a) either 3/4 inch or M20 bolts in 22 mm holes;
- b) either 7/8 inch or M22 bolts in 24 mm holes;
- c) either 1 inch or M24 bolts in 27 mm holes.

Oversize or slotted bolt holes will be allowed only in special circumstances.

Punched holes shall be clean cut, without torn or ragged edges. The diameter of the die shall not exceed the diameter of the punch by more than 2 mm. If a punched hole must be enlarged to admit a high tensile bolt, it shall be reamed.

Reamed holes shall be cylindrical and perpendicular to the member. Where practicable, reamers shall be directed by mechanical means. Reaming shall be done with twist drills or reamers.

Drilling shall be done with twist drills or core drills. Burrs on the outside surfaces shall be removed.

Poor matching of holes will be cause for rejection.

421.31.06 Faying Surfaces – All faying surfaces of steelwork shall be cleaned by sand blasting in the shop. Faying surfaces of steelwork to be painted shall be painted only with one coat of inorganic zinc primer. Primer coatings shall meet the Class B coating requirements as specified in CAN/CSA-S6-06. The class of coating shall be determined based on testing in accordance with the “Specifications for Structural Joints Using ASTM A 325 or A 490 Bolts” issued by the Research Council on Structural Connections. Primers shall be supplied with a Class B certificate and be applied and cured at the conditions on the certificate. Over thickness will not be accepted. If over thickness occurs then the surface will be cleaned and recoated at the Contractor’s expense.

421.32 Marking – Prior to fabrication, all steel shall be marked for identification by heat number and specification by a marking system approved by the Ministry. Steel, which is unidentified, shall not be used in the work.

421.33 Assembly of Weldments – The shop assembly of the various components of the weldments shall be executed in accordance with CSA W59.

Tack welding shall be done by qualified welders, using the smallest size weld required to hold the components of the assembly together. Tack welds shall be incorporated in the final weld.

421.34 Preheat and Interpass Temperatures – No welding shall be done when the temperature of the base metal is lower than -18°C. At temperatures below 0°C, the steel shall be preheated to a temperature of at least 10°C in excess of that stated in CSA W59, Table 5.3.

Preheat shall be applied to all steel to be welded so that the steel within the greater of 75 mm of the weld, or the thickness of the thickest part to be welded, is heated to the temperature shown in CSA W59, Table 5.3.

Preheat shall be applied in such a manner that moisture from the heating equipment does not penetrate the joint.

Preheat temperatures above the minimum shown in CSA W59, Table 5.3 may be required for highly restrained

joints if designated by the Ministry.

Preheat and interpass temperatures for repair of fracture critical members shall be in accordance with CSA S6-06 Table 10.15.

Preheat temperature shall in no case exceed 200°C.

Preheat requirements for tack welds shall be as in the above table except that where single pass tack welds are used and are to be incorporated and consumed in a weld made by the submerged arc process, preheat is unnecessary.

421.35 Welding – Welding shall be done by the shielded metal arc, metal-cored arc, flux-cored arc or submerged arc processes in accordance with the reviewed procedures and CSA W59, Section 5.

Any weld between the web and flange of a bending member shall be made by a mechanized submerged arc process, which provides a continuous weld throughout the length of the member.

All welding shall be done under cover and, in the case of flux-cored arc welding, shall be done in an area free from wind or draft.

Where the submerged arc process is to be used, the Contractor shall:

a) Carry out a preliminary test run of the procedure over the length of the joint to prove that the disposition of the equipment, the handling of hoses, and the method and accuracy of travel are satisfactory.

b) Have each operator make a weld specimen not less than 1200 mm in length for fillet welds and 150 mm in length for butt welds. Steel of the same specification and thickness as that to be used in the work shall be used in the specimen welds. No welding shall be done on the work until such a specimen is satisfactory to the Ministry.

Butt welds shall be extended beyond the edges of the parts to be joined by means of start and run-off tabs providing sufficient thickness to avoid the weld burning through and with a joint preparation similar to that on the main material. For manual shielded metal arc welding the width of the tabs shall be not less than the thickness of the thicker part being joined or 75 mm, whichever is greater. For submerged arc, welding the width of the tabs shall be not less than 75 mm. Each weld pass shall be carried far enough beyond the edge of the parts being joined to ensure sound welds in the joint. Tabs shall be removed upon completion, and the weld cooled without damage to the parent plate. The end of the weld shall be made smooth and flush with the edges of the abutting parts.

In flux-cored arc welding the equipment shall be capable of sustaining a gas flow rate of from 0.85 to 1.25 m³/h.

421.36 Shear Connector Studs – Shear connector studs shall be welded in the locations shown on the Drawings, to the requirements of CSA W59, Section 5.5.6. Shear

connectors will be inspected and shall be repaired if necessary in accordance with the same standard.

421.37 High-Strength Bolts – Installation of high-strength bolts shall be in accordance with the AASHTO Specifications for Highway Bridges (17th Edition – 2002 including all subsequent interim revisions and updates), Division II, Section 11.5.6.

Galvanized bolts shall be lubricated with beeswax or other approved lubricant before installation.

Heads of bolts shall be placed on the outsides of girders and box members, and generally on the more conspicuous side, if any, of any connection.

421.38 Bent Plates – When bending plates, the plates shall be so taken from the stock plates that the bend line will be at right angles to the direction of rolling. The radius of the bend measured inside shall be not less than the thickness of the plate. Before bending, the corners of the plate shall be rounded to a radius of 2 mm throughout that portion of the plate at which bending is to occur.

421.39 Shop Assembly of Bolted Connections – Holes in girder and truss field splices shall be drilled while assembled in the shop, or sub-punched or sub-drilled and reamed while assembled. Unless otherwise specified, the structure shall be progressively assembled in accordance with AASHTO Standard Specifications for Highway Bridges (17th Edition – 2002 including all subsequent interim revisions and updates), Division II, Section 11.5.3.1. The Ministry shall be provided sufficient notice by the Fabricator, to allow inspection of any assembly, including camber, alignment and accuracy of holes before drilling or reaming is commenced.

Connecting parts assembled in the shop for the purpose of reaming or drilling holes shall be match-marked by a method agreed to by the Ministry to indicate the location and orientation of all pieces.

Alternatively, the Contractor may drill holes full-size using automatic drilling equipment, as described in AASHTO Standard Specifications for Highway Bridges (17th Edition – 2002 including all subsequent interim revisions and updates), Division II, Section 11.4.8.3. In this case a check assembly will be required for the first of each major structural type, as described in AASHTO Standard Specifications for Highway Bridges (17th Edition – 2002 including all subsequent interim revisions and updates), Division II, Section 11.5.3.3. Reaming of holes shall be as specified in SS 421.47, if the bolt holes do not line up during field assembly.

Progressive assembly in the yard may be allowed, subject to approval by the Ministry, provided the Fabricator can demonstrate that yard assembly will provide as high a quality product as shop assembly.

421.40 Dimensional Tolerances – The dimensions of completed members shall comply with the appropriate

dimensional tolerances as specified in CSA W59.

The maximum deviation from specified length shall be $\pm L/1000$ but not over 20 mm.

Warpage of box members shall be determined by taking measurements at any two cross-sections in a member, at opposite edges of one face of the member. Warpage is defined as the distance by which any point deviates from a plane defined by the other three points. This warpage shall not exceed 1/200 of the width of the member, or 3 mm, whichever is greater.

421.41 Machined Surfaces – Machine-finished surfaces, as designated on the Drawings, shall be coated with an approved protective compound.

421.42 Galvanizing or Metallizing (if required) – All steelwork to be galvanized shall be galvanized after complete fabrication to the requirements of CAN/CSA-G164-M. The galvanizer shall safeguard against embrittlement as required in CAN/CSA-G164-M, Appendix A. Galvanized members shall be subject, at the discretion of the Ministry, to the tests for embrittlement outlined in CAN/CSA-G164-M, Section 5.5.

The chemical composition of steel being galvanized shall be as follows:

- Carbon less than 0.25%
- Phosphorus less than 0.05%
- Manganese less than 1.35%
- Silicon less than 0.03% or between 0.15% and 0.25%

For steel not meeting these chemical composition requirements, special galvanizing techniques shall be developed by the galvanizer to ensure that the specified coating thickness and adherence is achieved. A detailed description of the special techniques shall be submitted to the Ministry Representative for review 2 weeks prior to galvanizing.

All steelwork to be metallized shall, after complete fabrication, be treated in accordance with the current CSA G189. The zinc coating shall not be less than 0.3 mm in thickness.

421.43 Shop Painting – The Drawings or Special Provisions shall specify whether the structure is to be painted, or what parts of a structure are to be painted. This subsection applies to those parts of the steelwork which are to be painted.

For weathering steel bridges, unless specified otherwise, all structural steel shall be painted for the larger of the following two distances from deck joint locations:

- 3000 mm; or
- 1.5 times the superstructure depth (including girder, haunch and slab thickness).

SECTION 421

STRUCTURAL STEELWORK

Coating work shall be in accordance with SS 16 unless noted otherwise in SS 421.

All steelwork, which is to be painted, shall be given three shop coats of paint – primer, stripe coat and midcoat. Paint shall be chosen from SS 308 System SS1. Paint shall be supplied by the Contractor.

The topcoat may be applied in the shop or in the field. The topcoat coat shall be chosen from either SS 308 System SS1 or SF2. If the topcoat is to be applied in the shop, then the Quality Control Program shall specifically address the integrity of the topcoat through to project completion.

Surfaces surrounding bolt holes at connection locations shall receive the prime coat only and shall be masked off so that no stripe coat, midcoat or topcoat paint will be under the bolt heads, washers or nuts. These masked off areas shall have the stripe coat, midcoat and topcoat paint applied in the field after installation of the bolts.

Faying surfaces shall receive the prime coat only, as per SS 421.31.06. Faying surfaces shall not be coated with the stripe coat, midcoat or topcoat paint.

Paint shall be applied in a covered area in accordance with the manufacturer's specifications and SS 216.

All edges, corners, crevices, bolts, nuts, protrusions and welds (unless ground flush) shall be stripe painted by brush for a width of 50 mm with the midcoat paint before the midcoat coat is applied. Stripe coating paint shall be applied as per SSPC-PA1 and may be applied by spray, but shall be brushed in. Stripe painting shall be allowed to cure before the midcoat coat is applied.

Unless a different coating is called for on the Drawings, the exposed steel surfaces of bearings, and bearing assemblies, shall be cleaned and painted as structural steelwork.

Surfaces shall be cleaned to "near-white" per SSPC-SP10 / NACE No. 2 and 50 μm to 75 μm (2 to 3 mils) sharp/angular profile.

The midcoat shall be applied to all surfaces including tops and sides of the top flanges, except faying surfaces and surfaces surrounding bolt holes. The midcoat shall not be applied until the primer and stripe coat are accepted by the Ministry Representative to be sufficiently cured.

Any surfaces inaccessible after erection, except faying surfaces and tops and sides of top flanges, shall be given in addition to the three shop coats, one coat of the topcoat paint appropriate for the paint system being used.

If the topcoat is to be applied in the shop, then the topcoat shall be applied after the midcoat is accepted by the Ministry Representative to be sufficiently cured.

The colour of the topcoat will be selected by the Ministry. For weathering steel, unless noted otherwise, the topcoat colour shall match the expected colour of the oxidized

surfaces. The proposed colour shall be subject to the acceptance of the Ministry Representative.

421.44 Marking and Shipping – Each member shall be marked by a method agreed to by the Ministry with an erection mark, corresponding to the mark shown on the erection diagram. Each member with a mass of over one tonne shall also be marked with the mass.

Members shall be loaded on trucks or cars in such a manner that they can be transported to and unloaded at their destination without being damaged.

After steelwork has been delivered to Site it shall be inspected by the Contractor's quality control inspector. The Contractor shall clean the steelwork after it has arrived at Site of any dirt, road salts, slush or other contaminants accumulated during transport and shall carry out any other surface preparation work necessary to meet the specified surface preparation requirements.

421.45 Field Assembly – The parts shall be accurately assembled as shown on the drawings and any matchmarks shall be followed. Hammering which will injure or distort the members shall not be done. Bearing surfaces and surfaces to be in permanent contact shall be cleaned before the members are assembled. Field connections shall have one half of the holes filled with bolts and cylindrical erection pins (half bolts and half pins) before final bolting. Fitting-up bolts shall be the same nominal diameter as the high tensile bolts, and cylindrical erection pins shall be 1 mm larger.

421.46 Straightening Bent Material after Fabrication – The straightening of plates and angles or other shapes shall be done by methods that will not produce fracture or other injury. Any proposed heating and straightening plan shall be submitted to the Ministry for review prior to commencing with the work. The heating shall not exceed the requirements of CSA W59, Clause 5.15. After heating, the metal shall be cooled as slowly as possible.

Following the straightening of a bend or buckle, the surface of the metal shall be carefully inspected for evidence of fracture, and if necessary, replaced or repaired to the satisfaction of the Ministry.

421.47 Misfits – For all primary connections, and secondary connections having eight or more bolts, 85% of the holes shall accept bolts without reaming. The remaining 15% may be reamed to accept the designed diameter bolts. The diameter of the reamer shall be the same as the drilled hole.

Holes in plates showing more than 5 mm of offset shall be cause for rejection of that plate. New plates, if necessary, shall be field drilled using the hole pattern in the senior member as a template.

421.48 Erection Tolerances – Unless otherwise specified, the misalignment of members after erection shall

be within the dimensional tolerances specified in CSA W59, but not over 50 mm.

Misalignment shall be measured from vertical lines in the case of columns or towers, and from lines joining the ends of any test length of a member.

Joints, which are required on the drawings to be milled to bear, shall have at least 75% of the entire contact area in full bearing. The separations of any remaining portions shall not exceed 0.25 mm except locally at toes of flanges where a separation of 0.60 mm is permissible.

Where joints are not milled, the opening shall not exceed 13 mm.

421.49 Field Painting – This section applies to those parts of the steelwork which are to be painted. Coating work shall be in accordance with SS 216 unless noted otherwise in SS 421. After the completion of all deck and overhead concrete work, steelwork shall be thoroughly cleaned of all rust, dirt, dust, oil and other foreign materials. Non-visible salts shall meet the SSPC-SP12 / NACE No. 5 NV-2 levels. The shop coats of paint shall be touched up as necessary.

421.49.01 Field Touch-up – Bare, rusty or damaged areas shall be cleaned to SSPC-SP11, Power Tool Cleaning to Bare Metal. Feather edges into the existing coating and build the coating as per SS 216. Build the coating using coatings from the specified SS 308 System. Coating system shall be from the same manufacturer as the shop coating system on the steel.

After installation, Type 3 bolts, nuts and washers in the areas to be painted shall be cleaned to SSPC-SP11, Power Tool Cleaning to Bare Metal. These bolts, nuts and washers shall then receive the prime coat, stripe coat, midcoat and topcoat paint.

The masked off surfaces surrounding the bolt holes at connection locations shall be cleaned and shall receive the stripe coat, midcoat and topcoat paint.

421.49.02 Topcoat – The topcoat coat shall be chosen from either SS 308 System SS1 or SF2.

If the topcoat has not been applied in the shop, then the steelwork shall be given one topcoat coat of paint applied in accordance with the manufacturer's specifications and SS 216.

The colour of the finish coat will be selected by the Ministry. For weathering steel, unless noted otherwise, the topcoat colour shall match the expected colour of the oxidized surfaces. The proposed colour shall be subject to the acceptance of the Ministry Representative.

At the completion of the contract, all steelwork, painted or unpainted, shall be cleaned of concrete spatter, mud, oil and other foreign materials.

421.50 Unpainted Weathering Steel – In the case of unpainted weathering steel, the outer faces of the girders

and stringers, which includes the exposed edge of the top flange, the underside of the top flange, the girder web, and the top, bottom and edges of the bottom flange, and any other surfaces mentioned in the Special Provisions shall present a uniform surface free of mill scale and, if necessary, shall be power washed and/or sandblasted per SSPC-SP6 prior to installation. Cleaning shall also include all shop marks located on the exterior faces of the girders, and in all areas of interior girders that are readily visible to the public, as determined by the Ministry Representative. Concrete splatter adhering to the steel surfaces after the construction of the deck shall be removed and the steel surfaces cleaned.

421.51 Touch-up of Galvanizing and Metallizing – All field welds and other damage in galvanized and metallized coatings shall be touched up as follows:

If the Drawings or Special Provisions call for touch-up by metallizing, the damaged areas shall be locally sandblasted to "near white" per SSPC-SP10 / NACE No. 2. All dry abrasive blast cleaned areas shall be metallized in accordance with CSA G189, to provide a zinc coating not less than 0.3 mm in thickness.

Otherwise, the damaged areas shall be thoroughly cleaned and painted with two coats of Ministry-approved organic zinc-rich paint.

QUALITY CONTROL PROGRAM

421.61 Quality Control Program – These Subsections describe the general Quality Control Program required by the Ministry for any Fabricator undertaking the fabrication of permanent steel bridges and steel bridge components.

The term "Quality Control" defines those activities that the Fabricator performs to conform to the contract.

The term "Quality Assurance" defines those activities that the Ministry performs to audit the Contractor's quality control program.

These Subsections contain statements of the Quality Objectives and Policies that the Ministry considers essential for successful and economical quality management. They also outline the Procedures and Documentation to implement and confirm that objectives are met.

The provisions of the Quality Control Program set forth in these Subsections shall apply to all steel bridges and bridge components contracted by or for the Ministry.

These Subsections require the establishment of a Quality Organization with the responsibility for the successful and timely implementation of all necessary Quality Control activities. Some positions shown in the Suggested Organization Chart may be held by the same individual. For example, the General Manager may also be the Contract Administrative Manager and the Purchasing

Manager. The Plant Superintendent may also be the Receiver and the Welding Supervisor.

421.62 Quality Objectives and Policies

421.62.01 Quality Objectives – The Quality Objectives of the Ministry cover all steel bridges and steel bridge components produced under contract to the Ministry, as follows:

- a) Completed products shall conform fully to the governing Codes and Specifications stipulated in the contract document.
- b) The Quality Control Program shall be fully integrated into the ongoing manufacturing activities of the Fabricator.
- c) The operations of the Quality Control Program shall protect the interests of the Ministry with respect to scheduled delivery date and contracted price.

421.62.02 Quality Policy – The Quality Policy ensures that the product meets the Quality requirements of the contract, is delivered on time, and is produced in a cost-effective manner.

The Quality Control Program applies to all stages of the design, drafting, procurement, manufacturing and testing of the product.

A Quality Control Manager shall be appointed with defined responsibilities in resolving quality matters and shall report to a senior management level. At each hold point, the Quality Control Manager shall:

- Document the successful completion of each stage as it progresses through fabrication and erection;
- Identify and report nonconforming components;
- Initiate or recommend disposition of nonconforming components;
- Verify corrections.

Any persons assigned to perform quality control inspections shall be other than those performing or directly supervising the work and they shall not report directly to immediate supervisors responsible for producing the work.

The Quality Control Program is not subordinate to any design, drafting, procurement, manufacturing or testing activities.

421.63 Scope of the Quality Control Program – The Quality Control Program governs the fabrication of steel bridges and bridge components for the Ministry of Transportation.

The General Manager shall be responsible for:

- adhering to the Quality Control Program in all respects.
- ensuring that completed bridges or bridge components shall conform fully to the applicable design, fabrication and welding codes stipulated in the Contract.

- ensuring that all required documentation is produced according to the Quality Control Program.

421.64 Range of Capability – The Fabricator shall provide the necessary knowledge, skill (in-house or on a contract basis) and equipment to perform the following work on steel bridges and bridge components:

- Design of connections and joints not shown on Drawings (if applicable);
- Preparation of shop fabrication drawings (if applicable);
- Preparation of bills of material;
- Preparation of material requisitions and purchase orders;
- Receiving, checking and storing materials for bridges;
- Layout, cutting, forming and fitting of parts;
- Assembly, tacking and welding;
- Dimensional checking and verification;
- Resolution of non-conformances;
- Documentation of all stages of work with capability of tracking all major components;
- Cleaning, painting, storing and shipping;
- Erection of bridges and bridge components (if applicable).

421.65 Drawings and Specifications – The Chief Draftsperson shall:

- obtain the latest revision of the design drawings and Specifications for the work;
- submit shop drawings and erection drawings to the Ministry for acceptance before commencement of the work;
- prepare material requisitions containing a full description of the material sizes, material specifications, and certifications required for conformance to the contract;
- deliver the material requisitions to the Purchasing Manager in ample time to permit ordering, delivery and documentation without delaying the work;
- issue requisitions for all sub-contracted drafting work and shall ensure that all conditions of the Contract are part of such sub-contracts.

The Chief Design Engineer shall be responsible for the design of any connections or joints not shown on the design Drawings; and for the design of the erection procedures and any special erection equipment needed.

421.66 Material Control – All materials for bridges and bridge components shall be ordered by the Purchasing Manager in full conformance with the material requisitions provided by the Chief Draftsperson.

The Purchase Orders shall contain all information necessary to ensure that materials purchased will comply fully with the terms of the Contract. Where mill certificates and test reports are required, it shall be so stated on the Purchase Order. Instructions shall state when the certificates and reports are to be delivered to the Fabricator.

If a supplier proposes a substitute for any material, the Purchasing Manager shall refer the proposed substitution to the Chief Design Engineer for review. If the substitute is acceptable to the Ministry the Chief Draftsperson shall amend all drawings and requisitions, withdraw old issues, and issue the new versions.

The Receiver shall:

- inspect all materials on arrival for conformance with the Purchase Orders;
- confirm that mill certificates and test reports are provided and that they correctly identify the materials delivered;
- arrange with the Plant Superintendent to store all materials for the Contract in segregated areas. Clear identification with the Contract shall be provided;
- issue a non-conformance report covering overage, shortage or damage to the materials, and copies of the report shall be provided to the Purchasing Manager and the Quality Control Manager.

The Purchasing Manager shall deliver all documentation to the Quality Control Manager for inclusion in the Quality Control file for the Contract.

421.67 In-Progress Inspection and Reporting – The Quality Control Manager shall ensure that only documented materials are used for the Contract.

All materials intended for incorporation into bridges, girders or complex parts shall be examined after cutting to size, forming and rolling. The Chief Inspector shall ensure conformance with the detailed shop drawings, shall report any non-conformance to the Quality Control Manager and shall order all work affected by the non-conformance to stop, pending approval of remedial action.

Before assembling any plate girders or complex parts, the surfaces of all materials shall be examined for imperfections revealed during previous fabrication operations. The joint edge preparation for all groove welds shall be verified as conforming to the Fabricator's CWB-approved welding standards and shall be within the acceptable tolerances.

After assembly of any plate girders or complex parts, and before commencing the strength welding, the assembly shall be checked for dimensional conformance. The Welding Supervisor shall ensure that the fit-up of all welded joints conforms to the approved welding standards.

The Quality Control Manager shall file a written report of verification with the General Manager and report any non-conformance.

421.68 Correction of Non-conformance – When a non-conformance is encountered, the Quality Control Manager shall determine a recommended disposition and obtain the Ministry's approval as quickly as possible.

If there is non-conformance to the material specification stipulated in the Purchase Order, the Purchasing Manager shall immediately find out the reasons for the delivery of non-conforming material. If the material is of a grade superior to that ordered, the Quality Control Manager and the Chief Engineer shall be notified. They shall verify that the material is an acceptable alternative in all respects, and this verification shall include consultation with the Ministry. If the material is of a grade inferior to that ordered, it shall be rejected and the correct material or a superior material shall be obtained.

If there is non-conformance of material delivery that will delay production, the Contract Administration Manager and Plant Superintendent shall be notified immediately. They shall be given revised delivery dates for the adjustment of production scheduling. The General Manager shall determine the alternatives available and shall notify the Ministry.

If there are non-conformities in material preparation, assembly, joint edge preparation and fit-up before strength welding, the Quality Control Manager and Welding Supervisor shall immediately review the non-conformance and notify the Chief Design Engineer who may require further investigation prior to submitting corrective action to the Ministry for approval. If the necessary corrective action will result in delay to production, the General Manager shall be notified for adjustment to the production schedule. The Plant Superintendent shall inform the Quality Control Manager when the corrective actions are being done so that conformance can be verified and the non-conformance report cancelled.

421.69 Welding – All welding on structural and mechanical components shall be done by the company certified to CSA W47.1 (Division 1 or 2), W47.2-M (Division 2.1 or better) and W186-M as applicable, and shall be done in accordance with the Fabricator's CWB-approved welding standards.

The edge preparations for all groove welds shall conform to the dimensions established in the approved welding standards.

If the joint is to be welded from one side only without back-gouging, the root gap and root face shall be checked to ensure conformance with the required geometry so that the root pass can be successfully completed.

The strength level and chemical composition of all filler materials used in structural and mechanical assemblies

shall conform to the approved shop drawings.

All welding consumables shall conform to the approved welding standards and shall be received, stored and conditioned according to the applicable welding standards.

Any preheat required before welding shall be according to the approved welding standards.

The welding procedure followed in welding any joint in a structural or mechanical component shall conform to the applicable Data Sheet in the approved welding standards.

All welders and welding operators welding on structural or mechanical contracts shall be qualified under the requirements of the CSA Standard governing certification.

421.70 Heat Treatment – This covers any post-weld heat treatment necessary to conform to the approved welding standards.

The Chief Design Engineer shall:

- decide whether any structural or mechanical components shall receive post-weld heat treatment to conform to the contract conditions or to the applicable Codes and Standards.
- inform the Chief Draftsperson of any such requirements so that they may be incorporated on to the approved shop drawings.

Any heat treatment stipulated on the approved shop drawings or contained in the approved welding standards shall be carried out at the appropriate time and according to the approved documents.

The Plant Superintendent shall ensure that any heat treatment stipulated is done according to the established procedures, shall obtain all documentation and reports, and shall deliver them to the Quality Control Manager.

421.71 Non-destructive Testing – The Ministry will test any weld by non-destructive testing methods, as described in SS 421.06.

The Plant Superintendent shall schedule the manufacturing operation to facilitate non-destructive testing.

If non-destructive testing of welded joints reveals imperfections that are marginally more than the acceptance standards, the Quality Control Manager shall consult with the Ministry regarding the location and nature of the imperfections. The effects of leaving minor defects in place shall be assessed in relationship to the loads carried by the joint and the possible adverse effects of making an unnecessary repair.

Weld repairs shall conform to the approved welding standards.

421.72 Calibration of Measurement and Test Equipment – All measurement and testing equipment owned by the Fabricator and used in the Quality Control Program shall be calibrated and re-calibrated at the

intervals and in the manner stipulated in the Manufacturer's Instruction Manuals. Any adjusting devices shall be sealed or otherwise protected from unauthorized adjustment or tampering.

421.73 Records Retention – The Fabricator's record file for each Contract shall contain the pertinent drawings, purchase orders, bills of material, material mill certificates, test reports, Quality Control documents, NDT reports and certificates of compliance.

The Fabricator's record file shall be made available to the Ministry's Inspectors upon request.

Items in the Fabricator's record file shall be retained as per company policy.

The Quality Control Manager shall ensure that each file is complete in all respects before it is placed in the Company archives.

421.74 Hold Points – In planning the work flow, the Fabricator shall coordinate with the Ministry Inspector to decide "hold" points for inspection or non-destructive testing. A list of hold points shall be drawn up by the Fabricator and the Ministry at a prefabrication meeting. The Ministry shall be informed of progress so that delays are minimized.

The "hold" points will typically include some of, but not be limited to, the following:

- verification of materials
- after plate is prepared for splicing
- after splicing of plates
- after web to flange weld
- after stiffeners are applied
- camber of girders
- shop assembly
- cleaning and coating
- bearing plate attachment
- shipping arrangements
- subassemblies.

Work shall not proceed past a "hold" point until it has been signed off by Quality Control and Quality Assurance. Reports shall be completed promptly.

421.75 Transportation and Installation Procedures – Transportation and installation procedures shall be prepared and submitted for review before any installation takes place on site. The procedures shall be sealed by a professional engineer experienced in bridge erection and registered with the APEGBC. Consideration shall be given to the following items during the preparation of the procedures:

SECTION 421

STRUCTURAL STEELWORK

- a) Girder Transportation
 - i) Brief description of hauling equipment;
 - ii) Location of girder support points;
 - iii) Engineering backup if supports vary from specifications.
 - iv) Details of coating protection during loading transporting and erection.
- b) Installation Drawings
 - i) Bridge site plan showing piers, abutments and access roads;
 - ii) Crane make, crane chart, boom length(s) and crane locations;
 - iii) Mass of girder and access to crane(s);
 - iv) Special installation equipment such as a launching truss, head frames and falsework.
- c) Commentary
 - i) Brief point form description of installation sequence.
- d) Bearings
 - i) Placement procedure for bearings to be included for multiple span continuous girders.
- e) Traffic Control
 - i) Any arrangements that will be made for road and/or rail traffic.

- f) Utilities
 - i) Safety and protection.
- g) Fall Protection
 - i) Method and date of installation as required in specifications.

PAYMENT

421.91 Payment

421.91.01 Supply and Fabrication – Payment for supply and fabrication of structural steelwork will be made at the lump sum price bid. Payment shall be for quality control, shop drawings, the supply, bending, cutting, assembly and welding of steelwork, including any galvanizing or metalizing required. Payment shall also cover trial assembly and storage as necessary.

421.91.02 Shipping and Erection – Payment for shipping and erection of structural steelwork will be made at the lump sum price bid. Payment shall be for quality control, erection drawings and the loading, shipping and unloading of steelwork. Payment shall also cover falsework if necessary and the erection of steelwork.

421.91.03 Painting – Payment for painting of structural steelwork will be made at the lump sum price bid. Payment shall be for the surface preparation and the supply, application and touch-up of paint as required.

FIGURE 1

SUGGESTED ORGANIZATION CHART FOR

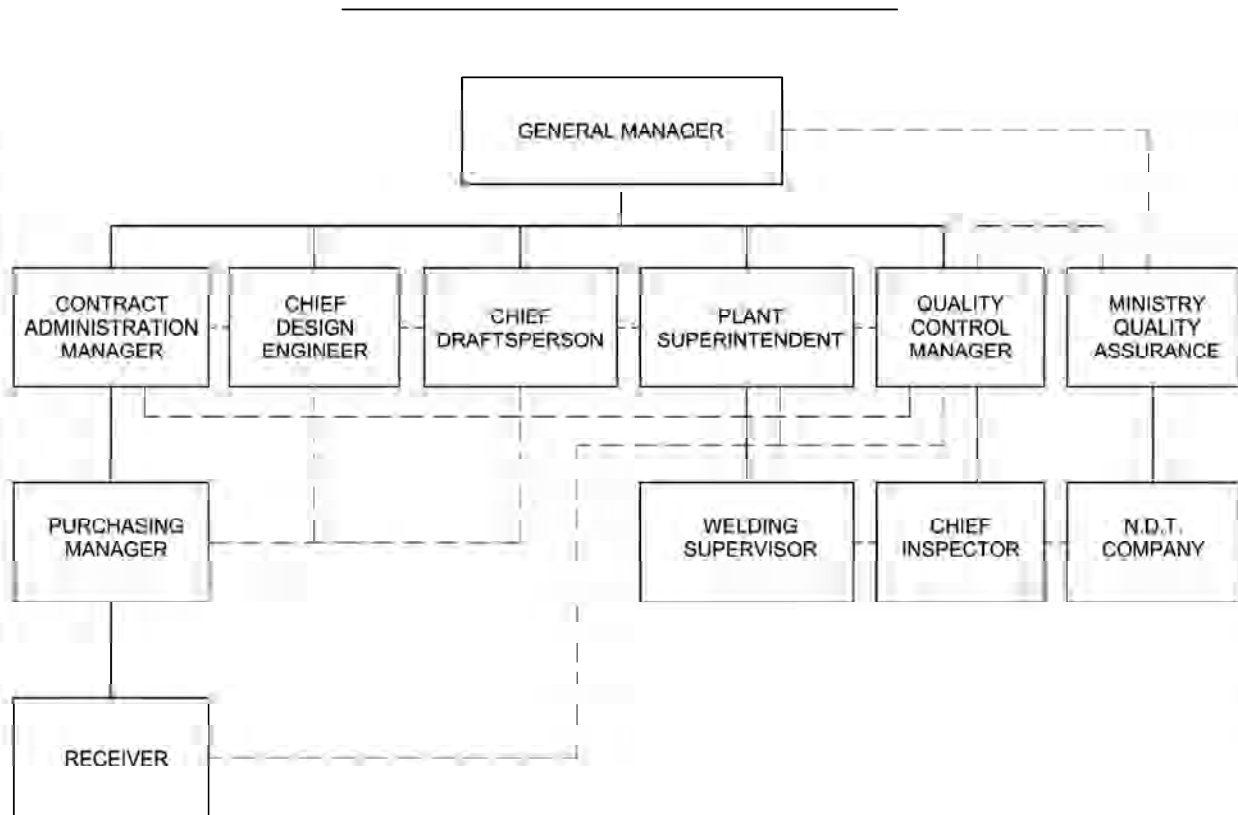

Direct Functional Reporting —————

Quality Control Reporting - - - - -

Signed _____
General Manager

DATE _____

SAMPLE FORM #2

NON-CONFORMANCE REPORT

BRIDGE NAME: _____ BRIDGE NUMBER: _____

JOB NUMBERS: _____

IDENTIFICATION DETAILS: _____

DESCRIPTION OF NON-CONFORMITY:

_____ 20_____
Date Signature

CORRECTIVE ACTION:

ACTION AGREED UPON: _____
Quality Control Supervisor Quality Assurance Inspector

DATE COMPLETED: _____ 20_____
Signature

HOLD REMOVED BY: _____ Date 20____

QUALITY CONTROL SUPERVISOR: _____ Date 20____

QUALITY ASSURANCE INSPECTOR: _____ Date 20____

SAMPLE FORM #3

MoT

Steel Fabrication Compliance Check List

BRIDGE NAME: _____ BRIDGE NO. _____

MARK NUMBER/S: _____

		Q.C.	Q.A.
Material:	Mill Certificates	_____	_____
	(Physicals, Chemicals, Impact Category)	_____	_____
	Identification on materials check	_____	_____
	Heat number transferred and recorded	_____	_____
Welding:	Procedures approved for each process	_____	_____
	Consumables checked	_____	_____
	Date Completed	_____	_____

SAMPLE FORM #4

MoT

Steel Fabrication Compliance Check List

BRIDGE NAME: _____ BRIDGE NO. _____

MARK NUMBER/S: _____

		Q.C.	Q.A.
Welding:	Weld preparation and fit up	_____	_____
	Welding within parameters	_____	_____
	Identification on materials check	_____	_____
	Shear studs	_____	_____
	Visual Inspection	_____	_____
	NDT outside agency results	_____	_____

		Q.C.		Q.A.
		Req'd	Actual	Verified
Dimensions:	Flanges Top Width 1	_____	_____	_____
	Width 2	_____	_____	_____
	Flatness	_____	_____	_____
	Tilt	_____	_____	_____
	Bottom Width 1	_____	_____	_____
	Width 2	_____	_____	_____
	Flatness	_____	_____	_____
	Tilt	_____	_____	_____
	Web Depth	_____	_____	_____
	Section Length	_____	_____	_____
	Bearing Ctr. Length	_____	_____	_____
	Sole Plate Contract	_____	_____	_____
	Camber	_____	_____	_____
	Sweep Tolerance (1/1000)	_____	_____	_____
	Splicing Camber Alignment	_____	_____	_____
	Holes	_____	_____	_____
	Date Completed	_____	_____	_____

SAMPLE FORM #5

MoT

Coating Compliance Check List

BRIDGE NAME: _____ BRIDGE NO. _____

MARK NUMBER/S: _____

		Q.C.	Q.A.
Coating:	WHMIS Safety Data Sheets	_____	_____
	Technical Spec. Sheets	_____	_____
	Surface Preparation	_____	_____
	Ambient Conditions – Req'd	_____	_____
	- Actual	_____	_____
	Application	_____	_____
	Test Results	_____	_____
	Date Completed	_____	_____

SAMPLE TAG #6

(Front Side)

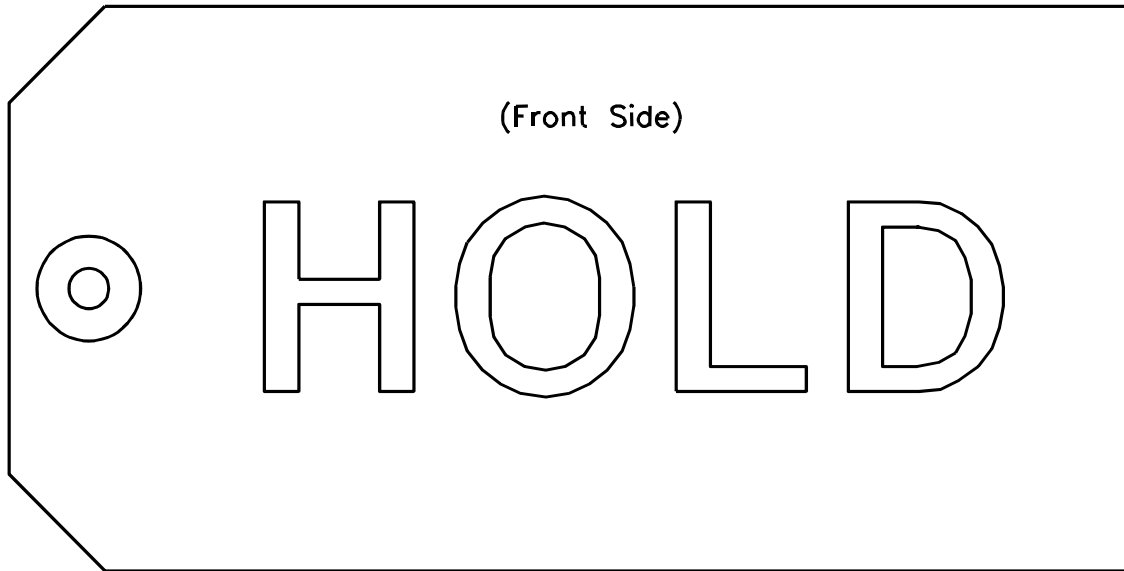

The front side of the sample tag is a rectangular shape with a slanted top-left corner. On the left side, there is a circular symbol consisting of two concentric circles. To the right of this symbol, the word "HOLD" is written in large, bold, outlined capital letters.

(Back Side)

Reason for Hold

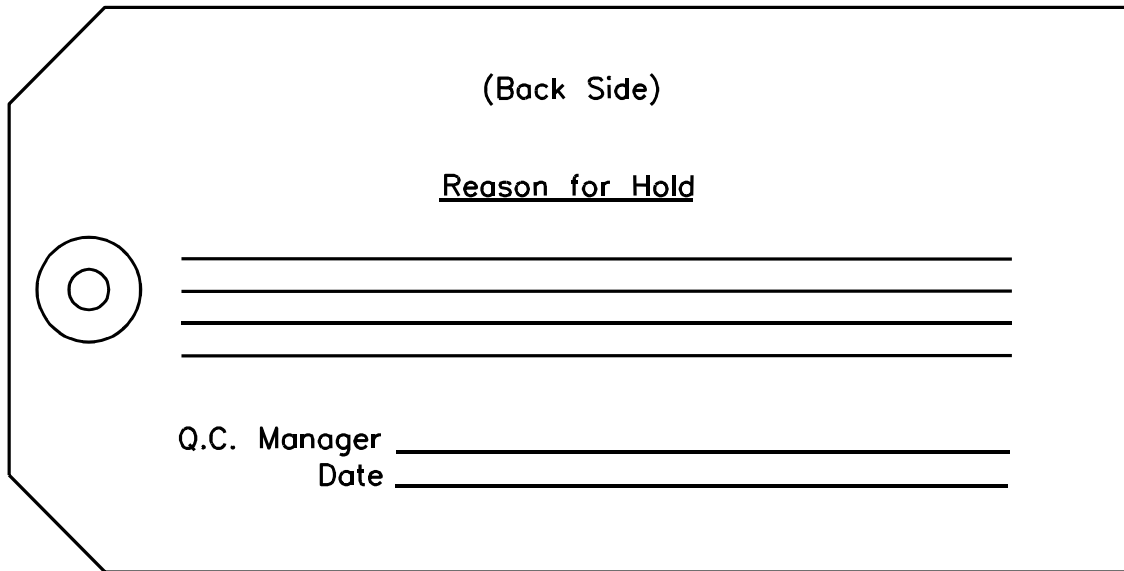

The back side of the sample tag is a rectangular shape with a slanted top-left corner. On the left side, there is a circular symbol consisting of two concentric circles. To the right of this symbol, there are three horizontal lines for writing. Below these lines, there are two lines for "Q.C. Manager" and "Date".

Q.C. Manager _____
Date _____

SECTION 422

MISCELLANEOUS STEELWORK

DESCRIPTION

422.01 Scope – This Section covers steelwork apart from major structural steel elements (see SS 421).

422.02 Adherence to Drawings – Steelwork items shall be fabricated in strict accordance with the Drawings.

422.03 Working Drawings – The working drawings shall show all information necessary for the fabrication of the steelwork.

Working drawings shall be in the same system of units as the design Drawings.

Working drawings shall be on D size sheets approximately 560 mm (22") by 865 mm (34"), (one drawing per sheet). Lettering for notes and dimensions shall be at least 2.5 mm and 4 mm for headings. Drawings shall be legible when half-sized or microfilmed.

In the case of simple items, where the design Drawings are complete enough to be used for fabrication, the Contractor may, with approval of the Ministry, dispense with working drawings. The Contractor shall notify the Ministry Representative of such intention in writing.

The Contractor shall submit to the Ministry Representative four sets of all working drawings, for the Ministry's information only, two weeks prior to the fabrication of the steelwork.

422.04 Inspection – The Contractor shall notify the Ministry Representative at least 14 days before fabrication. The Contractor shall allow the Ministry's representatives access to all parts of the work, and shall supply such information and assistance as is required. The Contractor shall provide samples of any materials, when requested by the Ministry. Inspection by the Ministry shall not relieve the Contractor from obligation to perform the work in accordance with the contract.

Any welding work found to be unacceptable shall be corrected in accordance with CSA W59, Section 5.10.

422.05 Rejections – The Ministry may reject any items which do not comply with the requirements of the contract.

MATERIALS

422.11 Materials – Structural steel, except where shown otherwise on the Drawings, shall conform to CAN/CSA-G.40.21-M, Grade 300 W or better.

Chemical composition of steel to be galvanized shall be in accordance with SS 422.36 – Galvanizing.

The quality and care of electrodes shall conform to the requirements of the latest CSA W59.

422.12 Storage of Materials – Structural material shall be stored above ground. It shall be kept free from dirt and other foreign matter, and shall be protected as far as

practicable from corrosion. Long members shall be supported on skids placed near enough together to prevent injury from deflection.

CONSTRUCTION

422.31 Welding – All welding shall be done in accordance with procedures approved by the Canadian Welding Bureau (CWB) and reviewed by the Ministry.

All welded fabrication shall be done to the requirements of the latest CSA W59.

Welding shall be undertaken by a company approved by the CWB to the requirements of CSA W47.1, Division 3 or better.

422.32 Welders and Welding Operators – The Contractor shall produce evidence that all welders and welding operators to be employed on the work are currently qualified by CWB in the processes in which they are to be employed.

422.33 Flame Cutting – Steel may be flame cut, using a mechanical guide, provided a smooth surface is secured. Flame cutting by hand shall be done only where approved by the Ministry, and the surface shall be made smooth by planing, chipping or grinding. The cutting flame shall be so adjusted and manipulated as to avoid cutting beyond the prescribed lines. Re-entrant cuts shall be filleted to a radius of not less than 10 mm. Edges of tension members shall be ground to a radius of 2 mm.

All exposed corners of members, which are to be painted, shall be ground to a radius of 2 mm.

422.34 Bent Plates – Plates to be bent shall be taken from the stock plates so that the bend line will be at right angles to the direction of rolling. The inside radius of the bend shall not be less than the thickness of the plates. Before bending, the corners of the plate shall be ground to a radius of 2 mm throughout the part to be bent.

422.35 Shop Painting – This subsection applies to those parts of the steelwork which are to be painted.

Coating work shall be in accordance with SS 216 unless noted otherwise in SS 422.

All steelwork, which is to be painted, shall be given three shop coats of paint – primer, stripe coat and midcoat. Paint shall be chosen from SS 308 System SS1. Paint shall be supplied by the Contractor.

The topcoat may be applied in the shop or in the field. The topcoat coat shall be chosen from either SS 308 System SS1 or SF2. If the topcoat is to be applied in the shop, then the Quality Control Program shall specifically address the integrity of the topcoat through to project completion.

Faying surfaces shall receive the prime coat only, as per SS 421.31.06. Faying surfaces shall not be coated with the stripe coat, midcoat or topcoat paint.

SECTION 422

MISCELLANEOUS STEELWORK

Paint shall be applied in a covered area in accordance with the manufacturer's specifications and SS 216.

All edges, corners, crevices, bolts, nuts, protrusions and welds (unless ground flush) shall be stripe painted by brush for a width of 50 mm with the midcoat paint before the midcoat coat is applied. Stripe coating paint shall be applied as per SSPC-PA1 and may be applied by spray, but shall be brushed in. Stripe painting shall be allowed to cure before the midcoat coat is applied.

Surfaces shall be cleaned to "near-white" per SSPC-SP10 / NACE No. 2 and 50 μm to 75 μm (2 to 3 mils) sharp/angular profile.

The midcoat shall be applied to all surfaces including tops and sides of the top flanges, except faying surfaces. The midcoat shall not be applied until the primer and stripe coat are accepted by the Ministry Representative to be sufficiently cured.

Any surfaces inaccessible after erection, except faying surfaces, shall be given, in addition to the three shop coats, one coat of the topcoat paint appropriate for the paint system being used.

If the topcoat is to be applied in the shop, then the topcoat shall be applied after the midcoat is accepted by the Ministry Representative to be sufficiently cured.

The colour of the topcoat will be selected by the Ministry. The proposed colour shall be subject to the acceptance of the Ministry Representative.

422.36 Galvanizing (if required) – All steelwork to be galvanized shall be galvanized after complete fabrication to the requirements of CAN/CSA-G164-M. The galvanizer shall safeguard against embrittlement as required in CAN/CSA-G164-M, Appendix A. Galvanized members shall be subject, at the discretion of the Ministry, to the tests for embrittlement outlined in CAN/CSA-G164-M, Section 5.5.

The chemical composition of steel being galvanized shall be as follows:

- Carbon less than 0.25%
- Phosphorus less than 0.05%
- Manganese less than 1.35%
- Silicon less than 0.03% or between 0.15% and 0.25%

For steel not meeting these chemical composition requirements, special galvanizing techniques shall be developed by the galvanizer to ensure that the specified coating thickness and adherence is achieved. A detailed description of the special techniques shall be submitted to the Ministry Representative for review 2 weeks prior to galvanizing.

422.37 Metallizing (if required) – All surfaces to be metallized shall be treated after complete fabrication in accordance with CSA G189. The zinc coating shall not be less than 0.3 mm in thickness.

422.38 Installation – Steelwork shall be installed as shown on the Drawings.

Railings and fences shall be adjusted to produce uniform height and smooth alignment.

Field welding will be permitted only as shown on the Drawings.

422.39 Field Painting (if required) – This section applies to those parts of the steelwork which are to be painted .

Coating work shall be in accordance with SS 216 unless noted otherwise in SS 422.

All steelwork shall be thoroughly cleaned of all rust, dirt, dust, oil and other foreign materials. Non-visible salts shall meet the SSPC-SP 12 / NACE No. 5 NV-2 levels. The shop coats of paint shall be touched up as necessary.

422.39.01 Field Touch-up – Bare, rusty or damaged areas shall be cleaned to SSPC-SP11, Power Tool Cleaning to Bare Metal. Feather edges into the existing coating and build the coating as per SS 216. Build the coating using coatings from the specified SS 308 System. Coating system shall be from the same manufacturer as the shop coating system on the steel.

422.39.02 Topcoat – The topcoat coat shall be chosen from either SS 308 System SS1 or SF2. If the topcoat has not been applied in the shop, then the steelwork shall be given one topcoat coat of paint applied in accordance with the manufacturer's specifications and SS 216.

The colour of the finish coat will be selected by the Ministry. The proposed colour shall be subject to the acceptance of the Ministry Representative

422.40 Touch-Up of Galvanizing and Metallizing – All field welds and other damage in galvanized and metallized coatings shall be touched up as follows:

If the contract documents call for touch-up by metallizing, the damaged areas shall be locally sandblasted to "near white" per SSPC-SP10. All sandblasted areas shall be metallized in accordance with CSA G189, to provide a zinc coating not less than 0.3 mm in thickness.

Otherwise, the damaged areas shall be thoroughly cleaned, and painted with two coats of Ministry-approved organic zinc-rich paint.

422.41 Clean-up – At the completion of the contract, all miscellaneous steelwork shall be cleaned of concrete spatter, mud, oil, shop markings if visible to the public and other foreign materials.

PAYMENT

422.91 Payment – Payment for miscellaneous steelwork will be made at the lump sum price(s) bid. Payment shall be for shop drawings and the supply, fabrication, galvanizing and/or painting if required and installation of the steelwork.

SECTION 502

ASPHALT PAVEMENT CONSTRUCTION (EPS)

(END PRODUCT SPECIFICATION)

PART A - GENERAL

502.01 Preliminary and General – This Section describes the materials, equipment, professional standards, and end product requirements for the construction of hot mix asphalt pavement and related shouldering operations.

End Product Specifications contain the acceptance and payment criteria based on the results of specified sampling and testing. Payment of the Contract Unit Prices for the asphalt pavement product is contingent on the product meeting the QC Plan, professional standards and quality requirements of this Section and is subject to payment adjustments upward and downward in accordance to the provisions provided in End Product Specifications (EPS).

When used in this Section and subject to the General Conditions:

- “acceptance” means agreement with past actions or decisions made, within the scope of the Contract.
- “authorization” means formal approval for future actions, frequently changing the Contract requirements.

502.02 General Description of the Work – Generally, the work associated with the construction of asphalt pavement and shouldering by EPS consists of the following:

- Preparing a Quality Control Plan for review before commencing the Work and providing at the production site a testing facility to provide the data needed to implement that plan;
- Supplying, screening, crushing, processing and improving aggregate to produce asphalt mix aggregate;
- Supplying and delivering asphalt cement and spray primer meeting the requirements of SS 952;
- Preparing mix designs which, once reviewed and accepted by the Ministry Representative, become the basis for the accepted Job Mix Formula;
- Heating the asphalt mix aggregate and mixing it with asphalt cement to produce asphalt mix that meets the Job Mix Formula;
- Hauling, placing, compacting and finishing the asphalt mix;
- Supplying, hauling, placing and compact shouldering gravels.

The Contractor shall provide an end product

conforming in professional standard, quality and accuracy of detail to the QC Plan and the dimensional and tolerance requirements of the contract. Where no tolerances are specified, the standard of workmanship shall be in accordance with normally accepted good practice and the provisions of this Section. Payment is subject to adjustments based on quality acceptance tests performed by the Ministry Representative and calculations performed by the Contractor with respect to application rate.

502.03 Definitions

Actual Asphalt Content – Actual asphalt content is the amount of asphalt cement in the mix as determined by the Ministry’s Quality Assurance Program.

Additives – solid or liquid materials to enhance the properties of the liquid asphalt cement or mix.

Aggregate – the crushed or screened gravel.

Asphalt Cement (AC) – a bitumen-based liquid binder used in asphalt pavement.

Asphalt Content – Asphalt Content means the quantity of asphalt cement in the mix expressed as a percentage by weight of the total dry aggregate in the mix.

Asphalt Mix (AM) – hot plant mixture of asphalt cement and aggregate.

Asphalt Mix Aggregate (AMA) – the processed crushed aggregate just prior to the addition of asphalt cement.

Asphalt Pavement (AP) – compacted asphalt mix.

Cutback Asphalt – asphalt cement which has been blended with light petroleum distillates.

Design Asphalt Content – The asphalt content upon which the Job Mix Formula is initially established.

Driving Lane – A driving lane shall mean a single lane in any area of the pavement other than a shoulder or a barrier flare.

Emulsified Asphalt – asphalt cement that has been blended with water and emulsifying agents to form aqueous emulsions, including anionic type, cationic type and high float type.

End Product Specification (EPS) – A specification whereby the Contractor is responsible for quality control of the construction processes, and whereby the Ministry reviews the workmanship and may perform

SECTION 502

the specified quality assurance sampling and testing of the end product for the purpose of determining acceptance/rejection and payment.

Job Mix Formula (JMF) – The asphalt mix “recipe”, proposed by the Contractor in accordance with SS 502.08.04 or an accepted variation in accordance with SS 502.08.10 and accepted by the Ministry, establishing the aggregate proportions, gradation, and the asphalt content to be used for production of asphalt mix.

Levelling Course (LC) – asphalt mix used to improve crossfall, level, and strengthen existing pavements.

Lift – A layer of asphalt mix laid in a single application then compacted.

Top Lift – The uppermost Lift, forming the final running surface.

Lower Lift – Any Lift below Top Lift.

Bottom Lift – The lowest Lift (excluding Level Course),

Lot and Sub-Lot – A Lot is a portion of the work being considered for acceptance and for the determination of payment adjustments. For density, AC content, gradation and smoothness, each Lot is comprised of a number of Sub-Lots, each of which is sampled, and then aggregated to determine the acceptability of the Lot. Lot and Sub-Lot sizes are defined in the appropriate payment adjustment provisions of this Section.

Reclaimed Asphalt Pavement (RAP) – Asphalt Pavement that has been removed and processed, for the purpose of recycling.

Recycled Asphalt Mix (RAM) – a carefully controlled hot plant mix of asphalt cement, graded high quality aggregate, and reclaimed asphalt pavement.

Reject Mix – asphalt mix that is deemed unacceptable for use in the project

Sample Mean – the arithmetic mean of a set of test results constituting the sample.

Smoothness – a measure of the longitudinal profile of the pavement surface, measured as International Roughness Index (IRI).

Sub-Lot – See Lot.

Surplus Aggregate – aggregate surplus to the works, in split or un-split stockpiles which singly or combined will meet the asphalt mix aggregate gradation.

Random Sample – a set of test measurements taken, one each from a number of separate areas or Sub-Lots within a Lot, in an unbiased way.

502.04 Quality Control

ASPHALT PAVEMENT CONSTRUCTION (EPS)

502.04.01 General – Quality Control shall be performed by the Contractor in accordance with SS 101 and the requirements of this Section.

502.04.02 Quality Control Plan – The paving component of the Contractor’s Quality Control Plan shall fulfill or exceed the requirements of Appendix 1 and function integrally with any other Quality Management provisions of the Contract.

The QC Plan shall be submitted in accordance with the timelines established in SS 101.02.03(iii).

The Quality Control Plan must include a detailed description of the means by which the Contractor shall use the quality control test results to ensure that the workmanship, asphalt materials, aggregate, mix production, paving and pavement compaction processes will be controlled to keep the product within the specified limits. The Quality Control Plan must clearly show the flow of information from the quality control laboratory to the individuals who shall make the actual adjustments to the processes and equipment to affect this control. The plan will show time allowance for each step, the names and positions of all the people involved, and a clear description of the responsibilities of each.

502.04.03 Quality Control Testing and Inspection – The Contractor shall provide and maintain equipment and qualified personnel to perform all laboratory testing, field testing and inspection necessary to determine and monitor the characteristics and properties of all the materials produced and incorporated into the work. They shall also monitor the workmanship of the final product in accordance with the Quality Control Plan as most recently submitted.

The Contractor shall provide a testing facility(s) that meets the requirements necessary to carry out all the test procedures listed within this Section. The facility(s) must have the equipment specified under the appropriate test designation to perform the tests. The Ministry shall have access at all times to the quality control facility(s).

502.04.04 Quality Control Records – Quality Control inspections shall be recorded on check sheets and/or diaries at the time of inspection.

The results from Quality Control testing shall be reported on test logs and plotted on charts immediately after each test is completed. The Contractor shall report all test results on Ministry-supplied forms (available from the Ministry Representative) or Contractor-supplied forms acceptable to the Ministry Representative.

For the purposes of confirming delivery of asphalt mix and shouldering aggregate to the road and the calculation of material application rates, the Contractor

SECTION 502

shall provide to the Ministry Representative a copy of the Road Checker's Summary and the weigh tickets for each load received at the placement operation at the end of each shift. The Road Checker's Summary shall include, but not be limited to, the following information:

- Truck Number.
- Weigh Ticket Number and Net Weight of load.
- Date, time and location by station of delivery.
- Material Application Rate Dimensions and Calculations. Calculation frequency minimally shall be for every 10 loads.
- Notes pertaining to the paving of any appurtenances (letdowns, intersections, tapers, etc.)

In addition to the equipment calibration requirements of SS 101, for the purpose of obtaining accurate and consistent results between the Contractor's Quality Control testing and the Ministry's Quality Acceptance testing, correlation of the Marshall hammer and ignition ovens to be used on the project shall be performed prior to mix production.

502.04.05 Final Quality Control Testing Reports – Prior to the issuance of a Completion Certificate, the Contractor shall provide the Ministry Representative with:

- a summary of all aggregate quality control test results;
- copies of all quality control test results for asphalt mix properties and compaction; and
- copies of all quality control charts.

PART B – MATERIALS

502.05 Materials Testing

502.05.01 Test Procedures – Where a test is specified to conform to an ASTM procedure, the correspondingly listed AASHTO test may be used, or vice versa. See Table 502-A Standard Sampling and Testing Procedures. **502.05.02 Sieve Sizes** – All aggregate gradation tests shall use the following sieve sizes: 37.5 mm, 25 mm, 19 mm, 16 mm, 12.5 mm, 9.5 mm, 4.75 mm, 2.36 mm, 1.18 mm, 0.600 mm, 0.300 mm, 0.150 mm, and 0.075 mm.

502.06 Aggregates

502.06.01 Aggregates – The Contractor shall supply all aggregates for the Work from sources acceptable to the Ministry Representative.

502.06.02 Work in Ministry Pits or Quarries – Ministry of Transportation pits offered in the Special Provisions as available sources may be used without charge provided they are developed and worked in

ASPHALT PAVEMENT CONSTRUCTION (EPS)

accordance with SS 145.26, SS 202 Part C, and the pit development plan. Deviation from the pit development plan will require the authorization of the Ministry Representative. No guarantee is given or implied that aggregate from Ministry pits will meet the Specification requirements or provide requisite quantities.

Without limitation and unless otherwise specified in the Special Provisions, the following items shall not be left in a Ministry pit:

- surplus milled or rubblized asphalt pavements,
- reject mix,
- fuel contaminated materials, or
- other waste products.

502.06.03 Supply of Aggregates, Aggregate

Production and Characteristics – The Contractor shall not produce aggregate until the Contractor has received written notification that their Quality Control Plan is in accordance with SS 502.04.02, and has in place testing facilities for aggregate production that are in accordance with the Quality Control Plan.

For the production of aggregate within Ministry pits, the Contractor shall follow the Ministry's pit development plan, and provide crushing equipment such that all aggregate which will pass through 375 mm x 450 mm slotted openings shall be used for the production of crushed aggregate. Rocks which will not pass through these openings shall be stockpiled as directed by the Ministry Representative. Crushing and screening equipment shall be provided with adequate facilities and capacity to be able to bleed off reject aggregate and remove any excess fine aggregate, dust or objectionable aggregate coatings, to make it generally acceptable for use. No portion of the products from crushing or screening plants that can be used shall be wasted, but shall be stockpiled or used as directed by the Ministry Representative.

Where the Ministry has available any test result information on the properties shown in Table 502-B, for a Ministry pit or other source, the Ministry Representative will upon request, provide that information to the Contractor. Otherwise, sampling and testing to determine and demonstrate the compliance of aggregate with the requirements of this Section shall be the responsibility of the Contractor.

502.06.04 Shouldering Aggregate – Shouldering Aggregate shall meet the following:

- All requirements of SS 202.04 and SS 202.05,
- Aggregate Properties and Gradation for 25 mm WGB, per SS 202 Table 202-B and Table 202-C, or as otherwise specified in the Contract or with the agreement of the Ministry Representative.

TABLE 502-A – STANDARD SAMPLING AND TESTING PROCEDURES

TEST REF. No.		STANDARD TEST METHOD / PRACTICE
AASHTO	ASTM	
AGGREGATES:		
T 11	C 117	Materials Finer than 75 μm (No. 200) Sieve in Mineral Aggregates by Washing
T 85	C 127	Density, Relative Density (Specific Gravity), and Absorption of Coarse Aggregate
T 84	C 128	Density, Relative Density (Specific Gravity), and Absorption of Fine Aggregate
T 27	C 136	Sieve Analysis of Fine and Coarse Aggregates
T 112	C 142	Clay Lumps and Friable Particles in Aggregates
T 255	C 566	Total Evaporable Moisture Content of Aggregate by Drying
T 2	D 75	Standard Practice for Sampling Aggregates
T 304	C1252	Method "A" Standard Test Methods for Uncompacted Void Content of Fine Aggregate (as Influenced by Particle Shape, Surface Texture, and Grading)
	D 421	Standard Practice for Dry Preparation of Soil Samples for Particle-Size Analysis and Determination of Soil Constants [aka Atterberg Limit]
T 176	D 2419	Standard Test Method for Sand Equivalent Value of Soils and Fine Aggregate
	D 4318	Liquid Limit, Plastic Limit, and Plasticity Index of Soils
	D 5821	Determining the Percentages of Fractured Particles in Coarse Aggregate
T 327	D 6928	Resistance of Coarse Aggregate to Degradation by Abrasion in the Micro-Deval Apparatus
ASPHALT CEMENT:		
T 49	D 5	Penetration of Bituminous Materials
T 202	D 2171	Standard Test Method for Viscosity of Asphalts by Vacuum Capillary Viscometer
ASPHALT MIX AND PAVEMENT:		
T 245		Standard Method of Test for Resistance to Plastic Flow of Bituminous Mixtures Using Marshall Apparatus
	D 979	Standard Practice for Sampling Bituminous Paving Mixtures
T 165	D 1075	Standard Test Method for Effect of Water on Compressive Strength of Compacted Bituminous Mixtures
	D 1188	Standard Test Method for Bulk Specific Gravity and Density of Compacted Bituminous Mixtures Using Paraffin Coated Specimens
	D 2041	Standard Test Method for Theoretical Maximum Specific Gravity and Density of Bituminous Paving Mixtures
	D 2726	Standard Test Method for Bulk Specific Gravity and Density of Non-Absorptive Compacted Bituminous Mixtures
T 269	D 3203	Standard Test Method for Percent Air Voids in Compacted Dense and Open Bituminous Paving Mixtures
	D 4469	Standard Test Method for Calculating Percent Asphalt Absorption by the Aggregate in an Asphalt Pavement Mixture
T-308	D 6307	Standard Test Method for Asphalt Content of Hot-Mix Asphalt by Ignition Method
SHOULDERING:		
	D 698	Standard Test Methods for Laboratory Compaction Characteristics of Soil Using Standard Effort (12,400 ft-lbf/ft ³ (600 kN-m/m ³)) [aka Standard Proctor]
	D 2922	Standard Test Methods for Density of Soil and Soil Aggregate in Place by Nuclear Methods (Shallow Depth)
	D6938-08	Standard Test Method for In-Place Density and Water Content of Soil and Soil- Aggregate by Nuclear Methods (shallow depth)
	D 5220	Standard Test Method for Water Content of Soil and Rock in Place by Neutron Depth Probe Method

502.06.05 Paving Aggregates – Paving aggregates shall meet the following requirements:

- a) Coarse Aggregates
 - i) shall be all mineral matter retained on the sieve designated in the test procedures for each individual test.
 - ii) shall consist of crushed stone, crushed gravel, or combination thereof, or materials naturally occurring in a fractured condition, or materials naturally occurring of highly angular nature or rough texture.
 - iii) shall be free from coating of clay, silt or other deleterious material.
 - iv) shall meet the requirements listed in Table 502-B.

TABLE 502-B – REQUIREMENTS FOR COARSE AGGREGATES

TEST_REF. #		PROCEDURES	Superpave	Class 1	Class 2
AASHTO	ASTM				
T 85	C 127	Maximum Water Absorption, % by mass	2	2	2
T 112	C 142	Maximum % by mass of clay balls and friable particles	1.0	1.0	1.5
	D 5821	2 Fractured Faces, Minimum % by Mass retained on the 4.75 mm sieve	90	85	70
T327	D 6928	Maximum Micro-Deval abrasion loss factor, %	18	15	20

- b) Fine Aggregate
 - i) shall be all mineral matter passing the sieve designated in the test procedure for each individual test.
 - ii) shall be clean, tough, durable, moderately sharp, and free from coatings of clay, silt, or other deleterious material, and shall contain no clay balls or other aggregations of fine material.
 - iii) shall have a sand equivalent of not less than 40 (not less than 45 for Superpave mixes) when tested in accordance with ASTM Test D 2419.

- iv) for Class 1 and Superpave mixes, shall have a minimum value of 45 when tested according the AASHTO Test T 304, Method “A”, - Uncompacted Void Content of Fine Aggregate when determining Fine Aggregate Angularity.
- c) Mineral Filler and Mineral Dust
 - i) Mineral filler shall consist of all matter passing the 0.600 mm sieve and mineral dust shall consist of all mineral matter passing the 0.075 mm sieve.
 - ii) Mineral filler and mineral dust shall be free from organic matter.
 - iii) Mineral filler shall be non-plastic when tested in accordance with ASTM Test D 4318.
- d) Additional requirements for Superpave Aggregates – Aggregates for Superpave mixes shall have properties and the gradation limits as specified below and in accordance with the latest version of the Asphalt Institute’s *Superpave Series Publication – Superpave Mix Design (current version)*. Changes and/or variations from these limits shall be outlined within the Contract Special Provisions.

- i) 90% fractured aggregate with a 12.5 mm nominal maximum size, including sufficient manufactured fines to provide fine aggregate angularity.
- ii) The aggregates must meet all the requirements for angularity, toughness deleterious materials, clay content, and flat and elongated particles.
- iii) Design ESALs will be 10 – 30 million.

502.07 Supply of Asphalt Cement and Primer – The Contractor shall supply the types and grades of asphalt cement and primers as specified in the Special Provisions and in accordance with SS 952. The supply of these materials includes, but is not limited to, ordering, scheduling delivery of, receiving, handling, storing, sampling, and testing of the materials and other related work.

The Contractor shall supply the Ministry Representative with copies of the asphalt supplier’s weigh-bill and records of all asphalt materials received on a daily basis.

502.08 Asphalt Mix

502.08.01 Responsibility for Asphalt Mix Design – Preparation and submission of the project asphalt mix designs for Ministry review is the responsibility of the Contractor. All costs incurred in mix design formulation are the responsibility of the Contractor.

SECTION 502

The Contractor shall utilise a qualified registered member of the Association of Professional Engineers and Geoscientists of British Columbia or a qualified, registered member of the Applied Science Technologists and Technicians of British Columbia who shall sign off the asphalt mix design. The Contractor shall also utilise a testing laboratory meeting the requirements of SS 101 and acceptable to the Ministry, to assess the aggregate material proposed for use and to carry out the asphalt mix designs.

502.08.02 Requirements for Asphalt Mix Design

a) **ALL MIXES** – Asphalt mix designs shall be performed using asphalt cement grade specified in the Special Provisions and which is from the same refinery contracted to supply the asphalt cement for the duration of the project.

Any subsequent change in the asphalt cement supplied by the Contractor will require a new asphalt mix design unless permitted otherwise by the Ministry Representative.

Asphalt mix designs, Job Mix Formulas, and field adjustments made in accordance with SS 502.08.10 must all be based on an aggregate gradation meeting the requirements of Table 502-C-1 and the criteria specified in Table 502-C-2 or Table 502-C-3, as applicable.

b) **MARSHALL MIXES** – The asphalt mix design for Class 1 and Class 2 pavements shall be carried out under Marshall design criteria using the designated equipment and procedures as contained in the Asphalt Institute's *Mix Design Methods for Asphalt Concrete MS-2*, latest edition.

c) **SUPERPAVE MIXES** – The Superpave asphalt mix design shall be carried out in accordance with the latest edition of the Asphalt Institute's *Superpave Mix Design, Superpave Series No. 2(current version)* and these Standard Specifications.

The JMF aggregate gradation shall fall under the maximum density gradation line for the 0.300 mm to 2.36 mm sieves inclusive.

502.08.03 Asphalt Mix Antistrip Additives – For Marshall, the Contractor shall determine the Index of Retained Marshall Stability (IRMS) of each asphalt mix in accordance with ASTM D 1075 "Standard Test Method for Effect of Water on Compressive Strength of Compacted Bituminous Mixtures". For Superpave mix designs, the Contractor shall determine the Tensile Strength Ratio (TSR) of each asphalt mix in accordance with AASHTO T 283-7 "Resistance of Compacted Bituminous Mixture to Moisture Induced Damage".

ASPHALT PAVEMENT CONSTRUCTION (EPS)

An antistrip additive shall be added to the asphalt mix when:

- the Special Provisions so direct;
- the IRMS is less than 85;
- the TSR is less than 80; or
- the Ministry Representative specifically requests it.

The Contractor shall select the antistrip additive from the Ministry's "Recognized Products List" and add it to all asphalt mix used in the Work, at an application rate of 0.3% additive by weight of asphalt cement. The Recognized Products list is available on-line at: http://www.th.gov.bc.ca/publications/eng_publications/geotech/Recognized_Products_Book.pdf

502.08.04 Asphalt Mix Design Submittals - The Contractor shall submit each asphalt mix design to the Ministry Representative for review that it complies with the requirements of the Contract, and shall not proceed until the review is received in writing from the Ministry Representative. The Contractor's submissions shall include the following information:

- The gradation of each aggregate to be used in each mixture.
- The percentage by mass of each aggregate to be used in each mixture.
- The design gradation of the combined aggregate for each mixture for each of the sieve sizes applicable to the mix, per the first column of Table 502-C-1.
- The estimated dry sieve gradation corresponding to the JMF gradation.
- All asphalt mix design data used in arriving at the final mix designs.
- The Design Asphalt Content expressed as a percentage of the dry weight of the aggregate.
- The Design Mix Temperature, which shall be the temperature at which the kinematic viscosity of the asphalt cement is 0.17 Pa•s (170 centistokes) or as per the Asphalt Cement supplier's recommendations.
- The recommended compaction temperature.

502.08.05 Review of Asphalt Mix Design - The Ministry Representative will require up to five (5) calendar days from the time of receipt of the asphalt mix design for review. The mix design must be reviewed prior to commencement of pavement construction.

When the Ministry Representative has confirmed in writing that the Contractor's asphalt mix design has been accepted, that asphalt mix design becomes the tentative Job Mix Formula for ignition oven correlation and the start of mix verification.

TABLE 502-C-1 – ASPHALT MIX AGGREGATE GRADATION LIMITS

SIEVE SIZE (mm)	PERCENTAGE PASSING BY MASS				
	Coarse Mix	Medium Mix		Fine Mix	Superpave ⁽¹⁾
	37.5 mm	19 mm	16 mm	12.5 mm	Nominal 12.5 mm
37.5	100				
25.0	80 – 100				
19.0	60 – 92	100			100
16.0	---	---	100		---
12.5	50 – 85	84 – 95	90 – 100	100	90 – 100
9.50	40 – 80	73 – 90	73 – 90	90 – 100	
4.75	30 – 65	50 – 75	50 – 75	55 – 80	---
2.36	20 – 50	35 – 57	35 – 57	32 – 64	28 – 58
1.18	15 – 35	26 – 45	26 – 45	24 – 51	
0.600	8 – 30	18 – 34	18 – 34	17 – 40	
0.300	6 – 22	10 – 26	10 – 26	13 – 29	
0.150	3 – 15	6 – 17	6 – 17	8 – 18	---
0.075	1 – 7	3 – 7	3 – 7	4 – 10	2 – 10

Note (1): from Appendix B in SuperPave SP-2

TABLE 502-C-2 – MARSHALL DESIGN and PRODUCTION CRITERIA

PROPERTY OF LABORATORY COMPACTED PAVING MIXTURE	PAVEMENT CLASS	
	1	2
Number of blows each face of test specimens	75	75
Minimum % Voids in Asphalt Mix Aggregate for 19 mm Medium Asphalt Mix	14	14
Minimum % Voids in Asphalt Mix Aggregate for 16 mm Medium Asphalt Mix	14.5	14
Minimum % Voids in Asphalt Mix Aggregate for 12.5 mm Fine Asphalt Mix	15	15
% air voids in laboratory compacted mixture for 19 mm Medium Asphalt Mix	2.5 to 4.5	2.5 to 4.5
% air voids in laboratory compacted mixture for 16 mm Asphalt Mix	2.5 to 4.5	2.5 to 4.5
% air voids in laboratory compacted mixture for 12.5 mm Fine Asphalt Mix	4 to 6	4 to 6
Minimum Marshall Load, N @ 60°C for 80 – 100 Pen. and 120 – 150 Pen.	9000	7000
Minimum Marshall Load, N @ 60°C for 150 – 200 and 200 – 300 Pen.	7000	6000
Flow index, units of 0.25 mm	8 to 14	8 to 16
Minimum Asphalt Film Thickness, μm (microns)	8.0	8.0
Minimum Index of Retained Stability after immersion in water at 60°C for 24 hours	85%	75%

TABLE 502-C-3 – SUPERPAVE DESIGN and PRODUCTION CRITERIA

PROPERTY OF LABORATORY COMPACTED PAVING MIXTURE For Design ESALs = 10 - 30 million, at N _{Design} = 100 gyrations	SUPERPAVE
% voids in the Mineral Aggregate, minimum	14
Required density: % of Theoretical Maximum Specific Gravity in a laboratory compacted mix at N _{Design} = 100 gyrations at N _{Initial} = 8 gyrations	95 – 97 ² <89
% voids filled with Asphalt Cement	65 – 75
Dust to Binder ratio ³	0.6 – 1.2

² For design Superpave density shall be 96. ³ Consideration shall be given to increasing the dust to binder ratio to 0.8 – 1.6

Upon acceptance of the tentative JMF, the Contractor shall prepare the laboratory equipment calibration samples, submit them to the Ministry Representative, and participate in the calibration and correlation process described in Appendix 3 Blank Aggregate sample Preparation and Appendix 4 Ignition Oven Correlation Procedure.

502.08.06 Ignition Oven Correlation – After receiving acceptance of the tentative JMF, the Contractor shall prepare blank aggregate samples (aggregate-only samples prepared to match the tentative JMF) for correlation of the Contractor, Ministry and appeal laboratory ignition ovens. Blanks shall be prepared in accordance with SS 502 Appendix 3 Blank Aggregate Samples.

The Ministry Representative shall randomly select which of the individual blanks will be used by each party.

Within 3 working days, and prior to any mix production, the Contractor and the Ministry shall prepare and test asphalt mix samples in accordance with SS 502 Appendix 4 Ignition Oven Correlation.

502.08.07 Use of Calibration Factors in Reporting Asphalt Cement Content – Results from testing of any asphalt mix shall report the measured AC Content and the corrected AC Content after applying the applicable laboratory calibration factor.

502.08.08 Verification of Job Mix Formula - Verification of the tentative Job Mix formula will be carried out by the Contractor during the course of production of the first 1,000 tonnes of mix. The Contractor will provide a tentative Job Mix Formula a minimum of five (5) days prior to production of any mix with supporting verification data, which shall include all the information, but not limited to, the requirements of SS 502.08.02, through SS 502.08.04 inclusive.

During the first 1,000 tonnes of plant production, the Contractor may make any adjustments it chooses to the tentative JMF, testing the mix, and refining the tentative JMF to a state that fully complies with Table 502-C-1 and 502-C-2 (or 502-C-3 as applicable).

All mix laid must be tracked by the Contractor, and reported to the Ministry Representative, as to lay-down location and the tentative JMF values in effect at the time that mix was produced, to ensure appropriate values are used in comparing design to sampled properties.

After production of the first 1,000 tonnes, the Contractor shall declare their production JMF to the Ministry Representative, and provide volumetric properties on the final mix produced. Any adjustments to the production JMF shall comply with all requirements of SS 502.

Where the production JMF varies from the tentative JMF by an amount greater than any tolerance specified in Table 502-D, the Contractor shall do a confirmatory mix design and report the results to the Ministry Representative.

502.08.09 AC Content Bump – Upon receipt of a production Job Mix Formula meeting all Contract requirements, the Ministry may direct the Contractor to increase the asphalt cement content by a “bump” of up to 0.3% by weight of dry aggregate in the mix.

502.08.10 Field Adjustment of Job Mix Formula - A field adjustment to the production Job Mix Formula is defined as a change in the asphalt cement content of the mix, aggregate gradation and/or proportioning of various aggregate sizes, within the specified limits as shown in Table 502-D without review and acceptance of a new asphalt mix design.

The proposed field adjustment shall be submitted in writing together with supporting documentation to the

SECTION 502

Ministry Representative. Within four hours of receipt of the proposed field adjustments, the Ministry Representative will review the field adjustment for conformance with the contract requirements and notify the Contractor whether or not it is acceptable.

TABLE 502-D – FIELD ADJUSTMENT OF JOB MIX FORMULA

Job Mix Formula Property	Maximum Field Adjustment
Percentage Passing by Sieve Size:	
• 37.5, 25.0, 19.0, and 16.0 mm	±2.0%
• 12.5 and 9.5 mm	±2.0%
• 4.75 and 2.36 mm	±1.5%
• 1.18 and 0.600 mm	±1.5%
• 0.300 and 0.150 mm	±1.5%
• 0.075 mm	±0.5%
Asphalt Cement content	±0.2%

The Contractor's field adjustment to the production Job Mix Formula must comply with the Asphalt Mix Design requirements of SS 502.08.02 through SS 502.08.04 inclusive. The Contractor shall provide all supporting verification data.

After the production Job Mix Formula has been established in accordance with SS 502.08.10, no field adjustment to that Job Mix Formula will be permitted without prior written authorization by the Ministry Representative. The Ministry Representative will limit the number of field adjustments to the Job Mix Formula originally derived from the laboratory mix design, to two.

No field adjustment will be acceptable if it results in a change from the Job Mix Formula, for any property, in excess of the maximum adjustment for that property permitted in Table 502-G. All production Mix shall meet either Table 502-C-2 or Table 502-C-3.

PART C – EQUIPMENT AND PLANT

502.15 All equipment and plant shall be in good mechanical condition and be capable of performing the Work in accordance with this section.

PART D - CONSTRUCTION

502.20 Minimum Acceptable Construction

Practices – Professional standards in accordance with the Contractor's QC Plan and construction industry best practices are a core requirement of the Work. Any construction practice or activity that results in an

ASPHALT PAVEMENT CONSTRUCTION (EPS)

obvious defect must be corrected by the Contractor. Construction practices shall include but are not be limited to the following:

502.21 Prime Coat and Tack Coat

Applications of Prime and Tack is required and shall be applied unless otherwise directed by the Ministry Representative.

502.21.01 Surface and Weather Conditions – The liquid asphalt for prime coat or tack coat shall be applied when surface and weather conditions are favourable. The application of prime and tack shall meet manufacturer's requirements.

502.21.02 Spray Temperature – The liquid asphalt shall be sprayed within the temperature range specified by the supplier.

502.21.03 Prepared Granular Bases and Old Pavements – All prepared granular bases or old pavements which are to be paved shall be prime coated or tack coated at specified rates.

502.21.04 Application – The spray bars shall produce double coverage at one pass, with uniform spray and even pressure with application rates controlled to within ±25% of the specified application rate.

Spray bar nozzles shall be of the same type and size, set to produce uniformly fan-shaped sprays without atomization.

502.21.05 Spraying Faults – Any spraying faults shall be corrected by the Contractor.

502.21.06 Excess Liquid Asphalt – Excess liquid asphalt remaining unabsorbed shall be blinded with sand or fine aggregate at no expense to the Ministry.

502.21.07 Surface Condition – The surface to be tack coated shall be cleaned of dirt or other foreign material.

502.21.08 Application – Tack coat shall not be applied on sections of roadway longer than will be covered by one day of asphalt plant production.

502.21.09 Traffic – Traffic shall not be permitted on tack coat until it has cured and on prime coat until the primer has been absorbed into the granular surfacing.

Where it is not possible to keep the traffic off the treated surface, the surface shall be blinded with sand or fine aggregate, at no expense to the Ministry, prior to allowing traffic on same.

502.21.10 Curing – Normally prime coats shall be allowed to cure for a minimum of 24 hours prior to the placing of asphalt mix and tack coats shall be allowed to cure to a state that minimizes tracking prior to the placing of asphalt mix.

SECTION 502

502.21.11 Maintenance - The Contractor shall, at the Contractor's expense, maintain the prime coat and/or tack coat.

502.22 Adjacent Mats, Joints, Edges, and Let-downs

502.22.01 Longitudinal Joints – Longitudinal joints in the Top Lift of asphalt pavement will only be permitted where lane dividing lines are to be painted. Longitudinal joints in a Lift shall be offset within 150 to 300 mm from joints in the underlying Lift. Joints shall be pinched as soon as practicable, using best compaction practices.

502.22.02 Longitudinal Edge – Any longitudinal edge that has been damaged by traffic or equipment shall be trimmed to provide a vertical abutting face. Vertical surfaces of roadway appurtenances shall be tack coated to the top of the new pavement only.

502.22.03 Contact Edge – The contact edge of abutting cooled asphalt pavement shall be thoroughly painted with a uniform coat of emulsified asphalt.

502.22.04 Paving Adjoining Mats – When paving an adjoining parallel mat there shall be at least a 50 mm overlap onto the previously paved surface. This overlap shall be properly constructed to form a homogeneous bond between the two mats.

502.22.05 Disposal of Raking Material – Any raked material from the joint shall not be placed on the new mat or placed in or in front of the paver. The Contractor shall dispose of the material in a manner acceptable to the environmental agencies and the Ministry Representative.

502.22.06 Discontinued Paving – When paving is discontinued in any lane on a traffic bearing roadway, the asphalt pavement shall be tapered down at a minimum slope of 25:1. When paving resumes this letdown shall be cut back so as to form a vertical face that matches the required depth being paved. Material removed from the taper shall be disposed of in a manner acceptable to the environmental agencies and the Ministry Representative.

502.23 Stockpiling Aggregates

502.23.01 Stockpile Construction – Stockpiles shall be constructed as specified in SS 202.21.

502.23.02 Stockpiles for Different Materials – Stockpiles of different types of material shall be located and constructed in such a manner as to prevent intermingling of the types and to prevent segregation.

502.23.03 Stockpile Requirements Prior to Mix Production – Before plant mixing commences, the Contractor shall have in stockpile a minimum of 20,000 tonnes of asphalt mix aggregate or 50% of the total quantity of asphalt aggregate required for the mix,

ASPHALT PAVEMENT CONSTRUCTION (EPS)

whichever quantity is greater. These quantities shall be maintained throughout the crushing period. These requirements may be waived by the Ministry Representative in circumstances where such stockpiles cannot be accommodated, such as where materials are being barged in or are being hauled to the plant from a remote site.

502.24 Mix Production

502.24.01 Mixing Temperature – The temperature of the asphalt mix measured at the plant discharge chute shall be maintained at $\pm 15^{\circ}\text{C}$ of the Design Mixing Temperature designated in the accepted Mix Design, with adjustments within that range made at the Contractor's discretion. Where the Contractor plans to adjust the actual mix temperature to 10°C or more above the Design Mixing Temperature, the Contractor shall notify the Ministry Representative prior to making the adjustment. To optimize mix properties during inclement weather or to address other specific circumstances, the Ministry Representative may agree, in advance, to a higher mixing temperature.

Any mix produced at a temperature above the upper tolerance limit may be deemed Reject Mix by the Ministry Representative.

502.24.02 Residual Moisture Content – The residual moisture content of the asphalt mix prior to compaction shall not exceed 1% by mass. Should foaming or bubbling persist, even below the allowed percentage of moisture, the Contractor shall modify operations accordingly.

502.25 Placing the Asphalt Mix

502.25.01 Surface Condition – Asphalt mix shall only be placed on clean dry surfaces free from all foreign materials, and when weather and conditions are suitable. Normally, asphalt mix is only placed when the ambient air temperature is 5°C and rising and for Top Lift when the average surface temperature is also above 5°C .

502.25.02 Asphalt Levelling Course Requirements – Asphalt Levelling Course shall be placed in one or more Lifts, with a maximum thickness of 75 mm per Lift. The amount of Levelling Course placed shall not exceed the quantity listed in Schedule 7 unless otherwise authorized in writing in advance by the Ministry Representative.

All asphalt mix shall be paver laid, unless otherwise authorized by the Ministry Representative.

Any mix laid prior to the establishment of the production Job Mix Formula (per SS 502.08.10) shall normally be placed in a location where performance of the mix is of lower concern, typically as level course, on a low volume side road, and/or in Bottom Lift. The

SECTION 502

location proposed by the Contractor shall be subject to the authorization of the Ministry Representative.

502.25.03 Lay-Down Operation – Asphalt mix should be delivered to the paver at a constant rate sufficient to allow continuous placement.

502.25.04 Traffic Control Person – A traffic control person shall be provided at each paver during asphalt mix lay-down operations. This individual's sole duty during asphalt mix lay-down operations shall be to ensure safe conditions.

502.25.05 Persons in the Vicinity of the Paver – When in the vicinity of an operating paver and in front of the screed, workers and inspectors shall stand in full view of the paver operator, clear of side arms, wings, and screed, and never directly in front of the machine hopper.

502.25.06 Vibrating Tampers and Hand Rollers – Along curbs, manholes, headers and similar structures which are not accessible to rollers, thorough compaction shall be obtained, by use of vibrating tampers and hand rollers or other suitable methods.

502.25.07 Traffic – Traffic will not be permitted on the finished pavement until it has cooled to such a temperature as to ensure that no deformation or flushing of the surface will occur.

502.25.08 Release Agents – Lubrication of the truck boxes, pavers, rollers or other equipment in contact with asphalt mix with diesel fuel will not be permitted. A list of potential alternative products evaluated by industry is available on the BC Safety network web page, "Resources"- "Diesel Alternative Committee": <http://www.safetynetwork.bc.ca/resources/dieselalt.pdf>

502.25.09 Ponding

Areas of ponding will be noted as an obvious defect and remedial works will be required.

502.26 Shoulder Build-up – Shoulder build-up is typically required where an existing roadway is being overlaid with wider shoulders. It involves construction of base course aggregate (adjacent to a Lift of pavement) which will be overlaid by one or more Lifts of asphalt. Shoulder build-up shall be constructed:

- a) in accordance with the SS 202.26;
- b) to the lines and grades indicated in the Contract, generally to a finished compacted level that matches level and grade of the adjacent asphalt level, and
- c) with cross-fall that matches that of the finished asphalt surface above the shoulder build-up area.

502.27 Shouldering

502.27.01 Shouldering Aggregate – Shouldering aggregate shall be 25 mm Well Graded Base (WGB), in accordance with SS 202, unless otherwise specified

ASPHALT PAVEMENT CONSTRUCTION (EPS)

in the Special Provisions or authorized by the Ministry Representative.

502.27.03 Lines and Grades – The finished surface of the granular shoulder shall be true to grade and cross section, and be free from ruts, segregation or other irregularities.

502.27.04 Aggregate Segregation – All granular shoulder materials shall be handled in such a manner that segregation does not occur.

502.27.05 Moisture Adjustment – If necessary for compacting, the moisture content of the shoulder aggregate shall be adjusted either through drying or applying water. Addition of water is incidental.

502.27.06 Compaction – Shoulders shall be thoroughly compacted to a state that will not rut more than 5 mm under a pick-up truck steering axle wheel load.

Where the base under the shoulder has been constructed as part of the Work, the degree of compaction of the granular shoulder measured in accordance with ASTM D 2922 shall be greater than 98% of the maximum dry density determined in accordance with ASTM D 698.

502.27.07 Adjacent Pavement Damage – If the adjacent asphalt pavement is damaged during the shouldering operation, the damage shall be repaired to the satisfaction of the Ministry Representative, at no expense to the Ministry.

502.27.08 Interim Shouldering – For safety reasons, when a roadway with gravel shoulders is used by the travelling public, an intermediate layer of shouldering aggregate shall be placed following final rolling of levelling course or multiple Lifts of asphalt pavement thicker than 50 mm, in advance of the main shouldering operation.

Should the Work extend past the Completion Date and be carried over to the next paving season suitable interim drainage control measures shall be put in place, all at no cost to the Ministry.

PART E – PAYMENT

502.30 General – Payment at the Unit Prices for the supply of primer/tack coat materials, the application of the spray primer/tack coat, the supply of paving aggregates into stockpile, the construction of asphalt pavement including the supply of asphalt cement, and for shouldering shall be full compensation for completing the supply and installation of asphalt pavement and shouldering on prepared surfaces in accordance with the contract requirements. Applicable payment adjustments (Additions or subtractions as applicable) shall be applied in accordance with Part F of this Section.

SECTION 502

Compensation for Quality Control shall be at the price bid for Quality Control or, in the absence of such a bid Item in Schedule 7 – Approximate Quantities and Unit Prices, incidental to the Work.

502.31 Acceptance at Adjusted Payment –

Acceptance of any Lot at adjusted payment will occur if it complies with the requirements of the QC Plan and Parts C and D of this Section, contains no obvious defects as per SS 502.32, and if:

- the test results for EPS acceptance parameters (density, gradation, asphalt content, smoothness, segregation, and application rate) are such that the Lot meets the requirements for acceptance at a reduced payment;
- the Lot is acceptable in respect of all other requirements; and
- the Contractor has not notified the Ministry Representative in writing that it will exercise its option to either repair or remove and replace the work, at its own cost, with work meeting the requirements for acceptance at full or increased payment.

502.32 Rejection For Workmanship Defects – Work may be rejected if it does not comply with the requirements of the QC Plan and Part D of this Section.

Additionally, the finished surface of any Asphalt Pavement Lift shall have a uniform texture and be free of visible signs of poor workmanship. Any obvious defects as determined by the Ministry Representative such as, but not limited to the following, may be cause for automatic rejection of asphalt pavement regardless of the values of any other acceptance parameter:

- individual bumps and dips that exceed 12 mm over 3 m;
- areas of excess or insufficient asphalt;
- improper matching of longitudinal and transverse joints;
- roller marks or roller pick-ups;
- excess tracking of prime or tack coat;
- areas contaminated by fuel oil or other deleterious materials;
- tire marks; or
- cracking or tearing.

When asphalt pavement is rejected by reason of obvious defects, the minimum area of rejection will be the actual length of the defect for the full width of the driving lane in which the defect exists.

Rejected work shall be promptly repaired, remedied, overlaid, or removed and replaced in a manner

ASPHALT PAVEMENT CONSTRUCTION (EPS)

acceptable to the Ministry Representative. The Contractor shall be responsible for all costs including materials.

No payment will be made for work in any Lot or Sub-Lot, which has been rejected, until the defects have been remedied.

502.33 Partial Payment for Rejected Work – In the Ministry Representative's sole discretion and without setting precedence, where any Work is reject but the Ministry Representative determines that it may be left in place, the Ministry Representative may authorize partial payment to the Contractor as full compensation for any residual value the Work may have. Notwithstanding the foregoing, the Ministry is under no obligation to make any payment for such Work.

502.34 Primer and Tack Coat

502.34.01 Supply of Primer and Tack Coat –

Payment to Supply Primer and Tack Coat shall be at the Unit Price per litre for the quantity of material actually sprayed onto the roadway measured prior to any additional diluting by the Contractor where applicable. The measured quantity shall not be greater than the total of the bills of lading.

Such payment shall be full compensation for supplying, handling, storing, sampling and testing of the material and all other related work.

502.34.02 Application of Primer and Tack Coat –

Payment for the application of Primer and Tack Coat will be at the Unit Price per litre of primer actually sprayed onto the roadway. In the case of an emulsion the payment quantity shall include any water added by the Contractor with the authorization of the Ministry Representative.

Such payment shall be full compensation for diluting the material when required and spraying it on the surfaces to be paved, and for all incidental costs arising from priming and tack coating.

502.35 Paving Aggregate into Stockpile –

Payment for Paving Aggregate into Stockpile shall be at the Unit Price per tonne for the quantity of paving aggregate placed into stockpile accordance with the following.

As the aggregate is crushed into stockpile, progress payments will be made against the bid item, up to the quantity shown in the "Approximate Quantity" column of the Schedule of Approximate Quantities and Unit Prices.

The final payment quantity for paving aggregate quantity will be equal to the corresponding asphalt mix quantity actually laid, without any adjustment for AC or moisture content. As a result, the final quantities and payments may vary from those used in prior

SECTION 502

progress payments; down if the mix quantity underruns and up if it overruns.

Such payment shall be full compensation for all work including but not limited to the production, supply and stockpiling of all paving aggregates.

502.36 Asphalt Pavement – Payment for Asphalt Pavement constructed in place shall be at the Unit Price per tonne for the quantity of mix placed in accordance with the Contract requirements.

Subject to the exception noted below, only acceptable asphalt pavement will be included in the payment quantity.

Where overlays are used as a corrective measure, in accordance with SS 502.58:

- the overlay quantity will not be included in the payment quantity, but
- the quantity of asphalt pavement covered by the overlay will be included in the payment quantity, whether or not it was acceptable.

Such payment shall be compensation in full for all work including but not limited to: loading the aggregate into the feeders; drying the aggregate; supplying, metering, and adding the asphalt cement; mixing, loading, weighing, hauling, dumping, spreading, compacting and finishing the asphalt pavement.

502.37 Asphalt Mix Antistrip Additives

502.37.01 Where Specified in the Special Provisions

– Where the Special Provisions direct the addition of an antistrip additive, all costs associated with supplying, storing, and blending the additive into the asphalt mixes shall be incidental to the prices bid for the varying classes of asphalt mix.

502.37.02 Where Not Specified in the Special Provisions – Where the Special Provisions do not direct the addition of an antistrip additive but the need was identified in accordance with SS 502.08.03, compensation for supplying, storing and blending the additive into the asphalt mixes shall be made at a negotiated price or on a Force Account Basis and any authorized payments will be made from the Provisional Sum for Site Modifications.

502.38 Asphalt Cement “Bump” – The Contractor will be compensated for additional oil ordered by the Ministry Representative in accordance with SS 502.08.09 at the AC cost FOB the asphalt plant, demonstrated by the AC supplier’s invoice, with mark-up on a Force Account Basis for the material only.

Payment will be calculated in accordance with the formula below, on a Lot-by-Lot basis based on the difference in asphalt cement content determined from

ASPHALT PAVEMENT CONSTRUCTION (EPS)

Ministry Quality Assurance (QA) samples and that in the Contractor’s production Job Mix Formula, to a maximum of the bump and a minimum of the Contractor’s proposed Job Mix Formula AC content. No compensation will be made for additional AC in any rejected mix.

$$\$_{Lot\ n} = 110\% \times Cost_{AC} \times t_{Lot\ n} \times \left[\left(\frac{AC_{Burn}}{100 + AC_{Burn}} \right) - \left(\frac{AC_{JMF}}{100 + AC_{JMF}} \right) \right]$$

Where:

$\$_{Lot\ n}$ = Compensation due for additional AC in Lot “n”

$Cost_{AC}$ = Supplier’s invoiced cost for AC, dollars per tonne

$t_{Lot\ n}$ = tonnes of asphalt mix laid and accepted in Lot “n”, including AC

AC_{Burn} = asphalt cement content (% dry mix) of Lot determined from Ministry QA samples, to a maximum of the bumped AC content and a minimum of AC_{JMF}

AC_{JMF} = asphalt cement content (% dry mix) of Contractor’s production Job Mix Formula before the bump

Note: 110% includes the percentage markup for materials paid on Force Account per GC 49.00.

502.39 Payment for Rejected Work Made

Acceptable – When defects have been remedied in Lots or Sub-Lots which had been rejected, payment for the original quantity of material in those Lots or Sub-Lots will be made subject to payment adjustments and penalty assessments and subject to SS 502.58.

No payment will be made for any material used to replace, repair or overlay rejected work and all corrective work shall be performed entirely at the Contractor’s expense.

502.40 Shouldering – Payment for Shouldering will be at the Unit Price bid per tonne or cubic metre (to the neat lines), whichever is specified in the Schedule of Approximate Quantities and Unit Prices. The price bid shall be full compensation for supplying, hauling, placing, moisture adjustment, and compaction of the aggregate to the required grades and crossfall.

502.41 Surplus Aggregate

502.41.01 Surplus Aggregate in Private Pits – At the discretion of the Ministry Representative, the Ministry may or may not purchase surplus aggregate in stockpile in a private pit. Generally the Ministry will provide payment for the processing costs of surplus aggregate in stockpile in Ministry Pits only, and only to a limited quantity. However, should the Contractor

SECTION 502

produce surplus aggregate in a private pit, and the Ministry intends to purchase these surplus aggregates, the Contractor shall be required to provide a written agreement with the owner of the property. This document shall indicate that the Ministry will have free access to and use of the surplus aggregate in stockpile for a period of 12 months after the completion of the contract work. If the Contractor undertakes private work from within the private pit, measurements for surplus aggregate in stockpile will not be taken until the completion of the private work, ensuring that the Ministry does not pay for aggregate used on private works. All surplus aggregate shall be properly stockpiled.

502.41.02 Ministry Purchase of Surplus Aggregate
- Should the Ministry proceed with the purchase of surplus aggregate, upon completion of the contract, the Ministry will purchase surplus paving mix aggregate as indicated herein. Surplus shouldering, surfacing, base and sub-base aggregates will be paid in accordance with SS 202.

If the quantity of Asphalt Pavement actually incorporated into the works is less than the estimated quantity, as stated in the Schedule of Approximate Quantities and Unit Prices, the Ministry will purchase aggregate up to 100% of the quantity required by the contract, to be paid under the appropriate Unit Price Item for Aggregate in Stockpile. The surplus aggregate must, when singly or combined, meet the gradation requirements set out in the Job Mix Formula.

The portion of material remaining in a stockpile eligible for compensation as surplus aggregate shall be the lesser of:

- a) the quantity of mix as stated in the Schedule of Approximate Quantities and Unit Prices minus the quantity of aggregate actually incorporated in the works, and
- b) the volume of the remaining stockpile as determined under SS 502.41.03

No payment shall be made for any surplus shoulder and paving aggregate remaining at contract completion in excess of the contract requirement. Material remaining in a Ministry pit is the property of the Ministry.

502.41.03 Measurement of Surplus Aggregate - The Ministry will determine the volume of aggregate by surveying the stockpile(s) using string-line techniques, and determine volume using prismatic volumes between surfaces. Alternatively, the Ministry Representative may elect to survey using cross-section techniques and/or determine volumes using end-area volumes.

ASPHALT PAVEMENT CONSTRUCTION (EPS)

The base of the pile will be determined from a pre-stockpile survey or, where such a survey is not available, from a surface determined by the Ministry Representative as being a reasonable interpolation from the intersection of the pile sides with the adjacent ground level. Where there are two or more stockpiles of aggregate meeting the same gradation classification, the compensation will be based on the cumulative quantity of those stockpiles.

Where necessary, stockpile volume shall be converted to mass using the conversion factor of 2.0 tonnes per cubic metre.

PART F – PAYMENT ADJUSTMENTS

502.50 Payment Adjustment – Payment adjustments resulting from the application of this Section will be effected on each progress payment as follows.

502.50.01 Density, Asphalt Content, and Gradation
– For each Lot paid for by the tonne (t), the applicable payment adjustment derived from Tables 502-E-1 or Table 502-E-2 (Density), 502-F (Asphalt Content), and 502-G (Gradation), in dollars per tonne, will be expressed as positive in the case of increases and negative in the case of decreases.

The algebraic sum of these unit adjustments will then be applied to the payment quantity for the Lot. The resulting amount, in dollars, will be the net payment adjustment, positive or negative, for that Lot.

502.50.02 Application Rate – Payment Adjustments from Table 502-H (Application Rate) shall be computed for the Lot.

The algebraic sum of the net payment adjustments for all such Lots for which payment is authorized on the current progress payment, computed in dollars, shall be the total payment adjustment for density, asphalt content, aggregate gradation, and material application rate for the current progress payment.

502.50.03 Segregation and Smoothness – For each Lot with payment adjustments based on kilometer (km), the applicable unit adjustment derived from Table 502-I-2 (Segregation) and Table 502-J (Smoothness), in dollars per Lot (\$/lane km), will be expressed as positive in the case of increases and negative in the case of decreases, and will be the payment adjustment, positive or negative, for that Lot.

The algebraic sum of the payment adjustments for all such Lots for which payment is authorized on the current progress payment, computed in dollars, shall be the total payment adjustment for segregation for the current progress payment.

502.50.04 Total Payment Adjustment – The algebraic sum of the total payment adjustments for density, asphalt content, aggregate gradation, material

SECTION 502

application rate, segregation and smoothness, derived in accordance with SS 502.50.01 through SS 502.50.03 above, shall be the total payment adjustment, positive or negative, in dollars, for all attributes for the current progress payment.

The total payment adjustment will be made by a single entry in computing the current progress payment.

502.50.05 Progress Payments – The process set out in SS 502.50.01 through SS 502.50.04 above will be used in computing each progress payment to which it is applicable.

502.51 Initial 1,000 tonnes of Mix

For the first 1,000 tonnes of asphalt mix produced under a Contract, the following provisions take precedence over all other payment and payment adjustment provisions of SS 502.52 through SS 502.57 inclusive, but do not take precedence over the rejection criteria.

502.51.01 Payment Adjustments – Unless requested otherwise by the Contractor in writing in advance of mix production, the first 1,000 tonnes of asphalt mix production and placement shall not be subject to the bonus/penalty payment adjustments for AC content, density and gradation. Payment adjustments will apply to smoothness, segregation and application rate if the mix is applied in a Top Lift location.

502.51.02 Acceptance Limits – Contrary to any other provision of SS 502, any mix produced during the initial 1,000 tonnes will only be considered acceptable if:

- a) the tentative JMF has been accepted by the Ministry Representative in accordance with SS 502.08.05;
- b) aggregate gradation per SS 502.08.02 is within the gradation limits specified in Table 502-C-1 or the banana formed by applying the Table 502-G column 3 variation limits to the JMF gradation;
- c) all other properties fall inside the allowable limits specified, in SS 502 and the Special Provisions, for the mix, including
 - For Marshall mixes, Table 502-C-2,
 - For Superpave mixes, Table 502-C-3; and
- d) AC content of the sample is within $\pm 0.5\%$ of the design value design value for top lift and is within $\pm 0.55\%$ of the design value for the bottom lift.

All values are measured against the tentative JMF value at the time the sampled mix was produced.

Any mix with any characteristic outside the above limits is Reject Mix.

ASPHALT PAVEMENT CONSTRUCTION (EPS)

Additionally, rejection limits for smoothness, segregation, density and application rate shall apply in accordance with SS 502 and the Special Provisions.

TABLE 502-D-2 – TEST SAMPLE SOURCE LOCATIONS

Test	Sample Source:
Density	100 mm dia. road cores; 150 mm dia. road cores for Superpave
AC Content	Loose Mix Samples
Smoothness	Centre of the Lane
Aggregate Gradation	Loose Mix Samples
Segregation	Roadway Pavement

502.52 Density

502.52.01 Lot – A Lot for density shall be one day's scheduled production of at least 7 hours plant production where no changes have occurred to criteria such as but not limited to:

- accepted Job Mix Formula,
- the specific Lift that is being placed,
- the required material application rate.

A change in any above criteria may require a new Lot designation.

Where one day's production is less than 7 hours, the material will be added to the next Lot that has the same criteria, as described above, except that if a test indicates that this production is subject to a payment adjustment or to rejection, or if no further material will be produced with the same criteria, this production will be designated as a separate Lot.

A Lot shall be no more than two days total production even if the above criteria have not changed or been met.

502.52.02 Sub-Lot – For density, a Lot shall be divided into three equal Sub-Lots, defined by lineal metres of production

502.52.03 Coring – The Contractor shall be responsible for providing all core samples for quality assurance and payment adjustment purposes. The randomly selected locations for the cores shall be supplied by the Ministry Representative to the Contractor. The Contractor shall provide 100 mm diameter cores for these purposes. For projects utilizing a Superpave product, 150 mm diameter cores shall be required. The Contractor shall prepare the cores prior to the submission by removing all material not representative of the pavement Lift to be tested.

SECTION 502

The Contractor shall deliver these cores to the Ministry Representative on site, within 24 hours of being provided the locations for the coring.

The Contractor shall fill all core holes before the roadway is re-opened to traffic. Core holes shall be filled by the following method:

- Empty the hole of water and loose material.
- Remove any excess moisture by wiping the inside with a dry towel.
- Tack coat the inside surfaces and the outside perimeter with an emulsified asphalt.
- Place asphalt mix in loosely, so that the compacted Lifts do not exceed 75 mm.
- With a minimum of 20 blows per Lift, compact the loose material using a minimum 2 kg sledge hammer and tamper.
- For additional Lifts repeat Steps (a) to (e).
- The final Lift shall be a minimum thickness of 25 mm, and finished to a level higher but not exceeding 6 mm, than the elevation of the surrounding pavement.

The Contractor may use an alternative method if acceptable to the Ministry Representative.

All costs associated with the obtaining the cores, including the filling and compaction of the core holes are considered incidental to the contract and are the responsibility of the Contractor.

502.52.04 Percent Density – The average in-place density will be determined from core samples of the completed Lift of pavement.

One random core sample will be obtained from each Sub-Lot and the test results for the three Sub-Lots will be averaged to determine the percent density for the Lot.

a) Marshall Mixes – For the determination of Marshall Briquette Density, the Contractor shall obtain the samples as outlined in SS 502 Appendix 2 for each Sub-lot. All costs associated with sampling, shall be the Contractor's responsibility.

From each Sub-lot sample, the Contractor will form three briquettes as per the procedure identified in Table 502-A and tested, and the ASTM D 2726 test results will be averaged to obtain the test value for that sample.

The Marshall Briquette Density for a Lot is the average of the test results from the three Sub-lots. The Marshall Briquette Density value for the Lot shall be provided to the Ministry Representative prior to the provision of the coring locations to the Contractor.

ASPHALT PAVEMENT CONSTRUCTION (EPS)

$$\text{Marshall Percent Density} = \left(\frac{\text{In-place Density of Sample}}{\text{Marshall Briquette Density}} \right) \times 100$$

At the discretion of the Ministry Representative, the Ministry may at any time, perform and use the Ministry results in accordance with procedures as outlined above, to obtain the value for Marshall Briquette Density which will replace the values achieved under the Quality Control Testing.

Should the initial test results in any Sub-Lot be lower than 97.0%, one additional core will be taken and tested, and that result shall replace and be averaged with the initial result to determine the percent density for the Sub-Lot.

In addition, the Contractor shall determine the individual Maximum Theoretical Densities (MTD) per ASTM D 2041 for each of the Sub-Lot samples and average the results of them to obtain the Lot MTD. The Contractor shall report the Lot MTD to the Ministry Representative prior to the provision of the coring locations to the Contractor.

b) Superpave Mixes – The Contractor shall determine the individual Maximum Theoretical Densities (MTD) per ASTM D 2041 for each of the Sub-Lot samples and average the results of them to obtain the Lot MTD. The Contractor shall report the Lot MTD to the Ministry Representative prior to the provision of the coring locations to the Contractor.

At the discretion of the Ministry Representative, the Ministry may at any time use the same procedures to obtain the values for Maximum Theoretical Density which will replace the values determined by the Contractor.

The average in-place density will be determined from 150 mm diameter core samples of the completed Lift of pavement.

$$\text{Superpave Percent Density} = \left(\frac{\text{In-place Density of Sample}}{\text{Lot MTD (ASTM D 2041)}} \right) \times 100$$

The Maximum Theoretical Density for a Lot is the value calculated defined as the average of the test results from the three Sub-Lots. The Maximum Theoretical Density value for the Lot shall be provided to the Ministry Representative prior to the provision of the coring locations to the Contractor.

Should the initial test results in any Sub-Lot be lower than 92.0%, one additional core will be taken and tested, and that result shall replace and be averaged with the initial result to determine the percent density for the Sub-Lot.

SECTION 502

502.52.05 Payment Adjustments – The payment adjustment for percent density will be the amount shown in Table 502-E-1 and 502-E-2 for the Sample Mean of the test results for the Lot.

502.52.06 Rejection Limit – The rejection limit for percent density is the limiting value of the Sample Mean as shown in Table 502-E-1 and 502-E-2. If any Sub-Lot has a value within the reject zone, the Sub-Lot is rejected and not paid for.

TABLE 502-E-1 – PAYMENT ADJUSTMENTS FOR DENSITY – MARSHALL

Marshall % Density Lot Average	Payment Adjustment (\$ per tonne)
≥ 98.5	+\$1.00
≥ 98.0 to < 98.5	+\$0.75
≥ 97.5 to < 98.0	+\$0.50
≥ 97.0 to < 97.5	+\$0.25
≥ 96.5 to < 97.0	-\$0.50
≥ 96.0 to < 96.5	-\$1.00
< 96.0	REJECT

TABLE 502-E-2 – PAYMENT ADJUSTMENTS FOR DENSITY - SUPERPAVE

SUPERPAVE % Density Lot Average	Payment Adjustment (\$ per tonne)
≥ 95.0	+\$1.00
≥ 94.0 to < 95.0	+\$0.75
≥ 93.0 to < 94.0	+\$0.50
≥ 92.0 to < 93.0	+\$0.25
≥ 91.6 to < 92.0	-\$0.50
≥ 91.0 to < 91.6	-\$1.00
< 91.0	REJECT

Acceptance or rejection will be determined for each Sub-Lot. One opportunity will be provided to the Contractor, using non-destructive test methods, to isolate the area of low density and conduct additional compaction providing no damage is incurred to the new pavement. The Contractor shall mark out the extents of the area identified using chalk or other temporary marking acceptable to the Ministry Representative. One additional core will be taken randomly in the area of low density and will replace

ASPHALT PAVEMENT CONSTRUCTION (EPS)

the core with previous low density and a new value will be calculated. The Ministry Representative shall be advised as to the scheduling of the re-compaction effort prior to the work taking place.

Where any Marshall mix core density is less than 96% (91% for Superpave mixes), the Contractor shall either overlay or remove and replace the previously placed area of reject mix. If the test result for density of a Sub-Lot is outside the acceptance limits, the Sub-Lot is rejected automatically regardless of the values of other acceptance parameters. To minimize the cost of rejection to the Contractor, the Contractor will be provided the opportunity to isolate the area of low density within the Sub-lot. The limits of the low density area must be verified and accepted by the Ministry Representative before remedial work proceeds.

502.52.06 Payment Adjustment for Density Rejected Work Made Acceptable – The payment adjustment for density will be based on testing of the replacement or overlay material where applicable. Where replacement or overlay material does not cover the entire Lot or Sub-Lot, prior tests of the uncovered area will be averaged with new tests on the corrective work.

502.53 Asphalt Content

502.53.01 Lot – A Lot for AC content shall be one day's scheduled production of at least 7 hours plant production where no changes have occurred to criteria such as but not limited to:

- accepted Job Mix Formula,
- the specific Lift that is being placed,
- the required material application rate.

A change in any above criteria may require a new Lot designation.

Where one day's production is less than 7 hours the material will be added to the next Lot that has the same criteria, as described above, except that if a test indicates that this production is subject to a payment adjustment or to rejection, or if no further material will be produced with the same criteria, this production will be designated as a separate Lot.

A Lot shall be no more than two days total production even if the above criteria have not changed or been met.

502.53.02 Sub-Lot – For AC content, a Lot shall be divided into three equal Sub-Lots, defined by lineal metres of production.

502.53.03 Determination of Asphalt Content – The asphalt content of the asphalt mix will be determined from loose mix samples obtained from each Sub-Lot (3

SECTION 502

per Lot) and tested in accordance with ASTM D 6307 test procedures listed in Table 502-A.

One random sample will be obtained from each Sub-lot as per SS 502 Appendix 2. The asphalt content of the asphalt mix will be determined using the average of the results obtained from all of the Sub-lot samples. The Actual Asphalt Content of the Lot will be compared to the Job Mix Formula Asphalt Content and the deviation will be used for payment adjustment purposes.

The ignition oven calibration factor will be applied to the AC Content measured by the ignition oven, and the corrected AC Content used to determine acceptability of the mix and any payment adjustments.

502.53.04 Payment Adjustments – The payment adjustment for asphalt content will be the amount shown in Table 502-F, where deviation in AC Content is determined by the percent difference, based on kg of AC per 100 kg of dry aggregate, between the JMF AC content and the actual AC Content.

502.53.05 Rejection Limit – Rejection limits for asphalt content are the limiting values of the Sample Mean as shown in Table 502-F, beyond which the Lot is rejected and not paid for.

If the asphalt content of a Lot is within the reject zone, the Lot is rejected automatically regardless of the values of other acceptance parameters.

For Top Lift deviations of more than 0.50% the Contractor shall either overlay or remove and replace the Lot.

For lower Lift deviations of more than 0.55%, no payment will be made and the Ministry Representative will determine whether removal and replacement is necessary.

502.53.06 Payment Adjustment for Asphalt Cement Content Rejected Work Made Acceptable –

The payment adjustment for Asphalt Content will be based on testing of the replacement or overlay material where applicable. Where replacement or overlay material does not cover the entire Lot or Sub-Lot, prior tests of the uncovered area will be averaged with new tests on the corrective work.

502.54 Aggregate Gradation

502.54.01 Lot – A Lot for aggregate gradation shall be one day's scheduled production of at least 7 hours plant production where no changes have occurred to criteria such as but not limited to:

- accepted Job Mix Formula,
- the specific Lift that is being placed,
- the required material application rate.

ASPHALT PAVEMENT CONSTRUCTION (EPS)

TABLE 502-F – PAYMENT ADJUSTMENTS FOR DEVIATION OF ASPHALT CONTENT (AC)

Differences of Actual AC Content From Designed AC Content Specified in JMF (AC in %)		
Actual AC Content	Payment Adjustment \$ per tonne	
(%) Greater than Specified in JMF	Top Lift	Lower Lifts
≥ 0.00 to ≤ 0.15	\$1.00	\$1.00
> 0.15 to ≤ 0.30	\$0.50	\$0.50
> 0.30 to ≤ 0.35	\$0.00	\$0.00
> 0.35 to ≤ 0.40	-\$2.00	-\$2.00
> 0.40 to ≤ 0.45	-\$3.50	-\$3.50
> 0.45 to ≤ 0.50	-\$5.00	-\$5.00
> 0.50 to ≤ 0.55	REJECT	-\$6.50
> 0.55	REJECT	REJECT
(%) Less than Specified in JMF	Top Lift	Lower Lifts
> 0.00 to ≤ 0.15	+\$0.50	+\$0.50
> 0.15 to ≤ 0.30	\$0.00	\$0.00
> 0.30 to ≤ 0.35	-\$2.00	-\$2.00
> 0.35 to ≤ 0.40	-\$3.50	-\$3.50
> 0.40 to ≤ 0.45	-\$5.00	-\$5.00
> 0.45 to ≤ 0.50	-\$6.50	-\$6.50
> 0.50 to ≤ 0.55	REJECT	-\$8.00
> 0.55	REJECT	REJECT

A change in any above criteria may require a new Lot designation.

Where one day's production is less than 7 hours the material will be added to the next Lot that has the same criteria, as described above, except that if a test indicates that this production is subject to a payment adjustment or to rejection, or if no further material will be produced with the same criteria, this production will be designated as a separate Lot.

A Lot shall be no more than two days total production even if the above criteria have not changed or been met.

502.54.02 Sub-Lot – For aggregate gradation, a Lot shall be divided into three equal Sub-Lots, defined by lineal metres of production.

SECTION 502

ASPHALT PAVEMENT CONSTRUCTION (EPS)

502.54.03 Determination of Aggregate Gradation – Table 502-C-1, Aggregate Gradation Limits, specifies the aggregate gradation limits which asphalt mix design, Job Mix Formulas, and field adjustments made in accordance with SS 502.08.10 must be based.

Table 502-G shows the limiting values for acceptance and for the determination of payment adjustments. These limits are expressed as departures, on each specified sieve size, from the percentage of material passing that sieve according to the Job Mix Formula. Aggregate gradation will be determined for each Lot from loose mix samples of the completed Lift of pavement. One random sample will be obtained from each Sub-lot, and the aggregate gradation for the Lot will be determined by using the average of the 3 Sub-Lot tests to determine the Sample Mean.

Although the JMF design gradation must at all times be maintained within the limits specified in the Aggregate Table 502-C-1, the gradation of the mix may vary outside those limits, subject to SS 502.54.05.

502.54.04 Payment Adjustments – Where the Sample Mean for every specified sieve size falls within the limiting values prescribed in a particular column of Table 502-G, the Lot will be accepted with a payment adjustment as indicated at the bottom of that column.

TABLE 502-G –PAYMENT ADJUSTMENTS FOR AGGREGATE GRADATION

Sieve Size mm	Divergence from JMF grading curve Percentage passing by mass (ASTM C 117 and C 136)		
	Column 1	Column 2	Column 3
12.5	±3.5	±4.5	±7.0
4.75	±3.0	±4.5	±6.0
0.600	±2.0	±3.5	±4.0
0.075	±0.75	±1.0	±1.5
Payment Adjustment \$ per tonne	+\$0.75	\$0.00	-\$1.50

502.54.05 Rejection Limit – Where one or more values of the Sample Mean for the specified sieves falls outside the limiting value specified in Table 502, Column 3, the Lot is reject and the Contractor shall either overlay or, remove and replace the previously placed mix. The Lot will be assessed to determine

whether it may remain in place, with payment made in accordance with SS 502.33.

502.55 Material Application Rate

502.55.01 Lot – A Lot for material application rate shall be one day’s scheduled production of at least 7 hours plant production where no changes have occurred to criteria such as but not limited to:

- the specific Lift that is being placed,
- the required material application rate.

A change in any above criteria may require a new Lot designation.

One day’s production of less than 7 hours will be dealt with as follows:

- the material will be added to the next Lot that has the same criteria, as described above, except that if a test indicates that this production is subject to a payment adjustment or to rejection, or if no further material will be produced with the same criteria, this production will be designated as a separate Lot,

A Lot shall be no more than two days total production even if the above criteria have not changed or been met.

502.55.02 Sub-Lot – Sub-Lots are not used for material application rate.

502.55.03 Determination of Material Application Rate – Asphalt mix shall be applied to the roadway at the rate or rates specified in the Special Provisions, on the Drawings or as otherwise directed by the Ministry Representative. Material Application Rates will be determined by the tonnage delivered to the paver as recorded by weigh tickets generated by automated scales, divided by the area covered by the Lot after allowance has been made for entrance letdowns and/or intersections. The Contractor shall provide the material application rate calculations to the Ministry Representative at the end of each shift.

502.55.04 Payment Adjustments – The payment adjustment for material application rate will be applied as shown in Table 502-H, based on the actual material application rate, expressed as a percentage of the specified material application rate.

502.55.05 Rejection Limits – Where actual application rate for the Lot is within the reject zone as shown in Table 502-H, the Lot is reject.

A Lot rejected for application rate may be corrected by mill-and-fill or rejected with no remedial work required, either subject to the authorization of the Ministry Representative.

SECTION 502

ASPHALT PAVEMENT CONSTRUCTION (EPS)

TABLE 502-H – PAYMENT ADJUSTMENTS FOR MATERIAL APPLICATION RATE

Actual Application Rate (Percent of specified rate)	Payment Adjustment \$ per tonne of material in the Lot (unless otherwise noted)	
	Bottom Lift or Single Lift	Top Lift of Multiple Lifts
≥ 110	-\$6.00 for all material in the Lot up to 110% and no payment for product in excess of 110.0%	-\$6.00 for all material in the Lot up to 106% and no payment for product in excess of 106.0%
≥ 106.0 to <110.0	-\$4.00	-\$4.00
≥ 105.0 to <106.0		
≥ 104.0 to <105.0	\$0.00	-\$2.00
≥ 96.0 to <104.0	+\$0.50	+\$0.50
≥ 94.0 to <96.0	-\$1.00	-\$1.00
≥ 92.0 to <94.0	-\$2.00	-\$2.00
≥ 90.0 to <92.0	-\$3.00	-\$3.00
≥ 85.0 to <90.0	-\$5.00	-\$5.00
<85.0	REJECT	REJECT

The Ministry Representative and the Contractor shall evaluate the first two Lots upon completion of the second Lot, after opening to traffic, to confirm the “agreed to” guidelines. Segregation will then be evaluated only when all paving is complete.

The Ministry Representative, with the Contractor’s Representative, will observe the finished pavement to evaluate the existence, severity and extent of segregation and other surface defects. The evaluation will be completed prior to the issuance of the Completion Certificate

The rating system for categorizing the severity of Top Lift surface segregation, and repair methodology is shown in Table 502-I-1.

502.56.04 Payment Adjustments – The payment adjustment for Top Lift segregation will be the applicable amount shown in Table 502-I-2.

502.56.05 Repair – On Top Lift all segregation, including any in areas outside the driving lanes assessed for the payment adjustment, shall be repaired according to Table 502-I-1.

502.56 Surface Segregation

502.56.01 Lot – A Lot shall be one kilometre length of Top Lift pavement for each driving lane.

502.56.02 Sub-Lot – Sub-Lots are not used for segregation.

502.56.03 Determination of Surface Segregation – The finished pavement shall be homogeneous, free from segregation and shall be uniform with respect to surface texture. A segregated area is defined as an area within the driving lanes of the pavement wherein the texture differs visually from the texture of the surrounding pavement.

Due to the nature of variation in asphalt mixes and their compactive characteristics, the definition of degrees of segregation will be established on a project by project basis. The Contractor and the Ministry Representative shall establish through the use of photographs or other mutually agreed tools, the definition of slight, moderate and severe segregation.

SECTION 502

ASPHALT PAVEMENT CONSTRUCTION (EPS)

TABLE 502-I-1 – SEGREGATION – TOP LIFT ONLY – REMEDIATION METHODOLOGY

Segregation Severity	Visual Appearance	Repair Procedures
None	Completely uniform surface texture.	N/A
Slight	Matrix of asphalt binder, coarse and fine aggregate exists; visually increased presence of stone sizes.	Sand cement slurry.
Moderate	Significantly more stone than surrounding pavement; matrix of asphalt binder and coated sand particles is reduced.	Seal coat or sand cement slurry patch or neat hot mix patch or mill and fill patch.
Severe	Appears as an area of very stony mix - stone against stone - little or no matrix.	Remove and replace or overlay to limits authorized by Ministry Representative.

TABLE 502-I-2 – SEGREGATION – TOP LIFT ONLY – PAYMENT ADJUSTMENTS

Payment Adjustment	Number of Segregated Areas, by Category		
	Slight	Moderate	Severe
+\$1,000 per lane km. <i>(Applies only if the criteria in all three adjacent columns are achieved)</i>	0 to 3	0	0
+\$500 per lane km. <i>(Applies only if the criteria in all three adjacent columns are achieved)</i>	4 to 5	0	0
No payment adjustment	6 to 10	0 to 1	0
-\$500 per lane km. <i>(Applies if the criteria in any one or more of the adjacent columns occurs)</i>	11 to 15	2 to 5	0 to 1
-\$1,000 per lane km. <i>(Applies if the criteria in any one or more of the adjacent columns occurs)</i>	16 or more	6 or more	2 or more

All segregation patch repairs shall be completed to a rectangular shape.

Repair shall be to the neat lines and dimensions of the segregated area using a sand cement slurry or other product acceptable to the Ministry Representative.

An acceptable sand cement slurry can be made as follows, with proportions varied as needed for workability:

- 25 litres of SS-1 (or equivalent) emulsion
- 4 – 5 kg (2 shovels) of ≤3 mm sand
- 2 – 3 kg (1 shovel) Type GU (general use) Portland cement
- Additional water, if needed for workability.
- Or other products approved

After repairs, the Lot will be re-evaluated for acceptance, but not for segregations payment adjustments.

The Contractor shall be responsible for all costs associated with the repair of segregated areas.

SECTION 502

502.57 Smoothness

502.57.01 Lot – A Lot for smoothness shall be one kilometre length of Top Lift pavement for each driving lane.

502.57.02 Sub-Lot – A Sub-Lot for smoothness shall be a 100 metre section of a Lot, or for the last Sub-Lot within a Lot, a section of up to 100 metres.

502.57.03 Traffic Control for Pavement

Smoothness Testing – The Contractor shall provide traffic control for smoothness testing.

The Ministry Representative will provide sufficient notice to the Contractor regarding when the Ministry will perform smoothness testing. As directed by the Ministry Representative, the Contractor will be responsible to schedule and provide traffic control for the Ministry's smoothness testing, including a shadow vehicle and all signage necessary. The Contractor shall also be responsible for sweeping and any other preparation work required for smoothness testing. No extra payment will be made for sweeping or other preparation work and the provision of traffic control for smoothness testing will also be considered incidental and no extra payment will be made.

The Contractor may also be required to provide an additional Shadow Vehicle or traffic control for smoothness testing as determined by the Ministry Representative. Payment for the provisions of an additional Shadow Vehicle or traffic control, if required, will be made under the Provisional Sum Item for Site Modifications.

502.57.04 Determination of Pavement Smoothness

– The finished pavement surface shall be tested by the Ministry using a Class I precision rolling profile measuring instrument, to determine the longitudinal profile and compute the International Roughness Index (IRI) in each driving lane. Profiles shall be measured and the IRI calculated in the centre of the lane for each Sub-Lot.

For any Sub-Lot between 50 m and 100 m in length, the IRI value shall be considered representative of a complete Sub-Lot. For any Sub-Lot less than 50 m in length, the IRI value will be combined with the preceding Sub-Lot IRI value.

The profile shall be measured over the entire length of the pavement exclusive of structures and shoulder areas. Acceleration, deceleration and turning lanes are considered part of the driving lanes and shall be tested in accordance with this provision. For the measuring process, the Contractor shall provide the Ministry Representative a chalk guide line in the centre of the lane immediately prior to measurement.

502.57.05 Auxiliary Lanes – For smoothness testing, sections of the driving lanes that do not fall within the

ASPHALT PAVEMENT CONSTRUCTION (EPS)

continuous through lanes, such as acceleration lanes, deceleration lanes and turning lanes, and lanes which are less than 1 km in length, shall be treated as follows. The ratio of the section length to the standard Lot length of 1 km shall be determined and the payment adjustment shall be pro-rated on this basis as in the following example:

For a segment 565 metres long, the payment adjustment factor is

$$\begin{aligned} &= \text{Length of segment} / \text{Length of standard Lot} \\ &= 565 \text{ m} / 1000 \text{ m} \\ &= 0.565 \end{aligned}$$

Hence the applicable payment adjustment is 0.565 times the payment adjustment for a 1 km Lot as determined from Table 502-J.

502.57.06 Sub-Lot and Lot Acceptance Limits –

The reject limit and payment adjustments applicable to a road for smoothness are specified in Table 502-J. The default values in the "Standard" column shall apply except where the Special Provisions specify that "Alternate" values apply.

The International Roughness Index (IRI) value, calculated for each Sub-Lot, will be used to determine if the Sub-Lot or Lot will be accepted, and if so whether it will be subject to any payment adjustment.

The Lot IRI is the average of the individual IRI values for the Sub-Lots within the Lot.

A Sub-Lot is rejected if:

- it has an IRI within the applicable reject zone shown in Table 502-J, subject to SS 502.57.08;
- for Top Lift only, there are obvious defects per SS 502.32 or it has unrepaired smoothness deficiencies which require remediation in accordance with SS 502.57.09.

A Lot is rejected for Smoothness if any Sub-Lot is rejected.

502.57.07 Payment Adjustments – For Top Lift only, the payment adjustments per the applicable column of Table 502-J shall apply to each Lot.

502.57.08 Remedial Work – If the test results on a Sub-Lot of pavement indicate a payment reduction or rejection because of smoothness, the Contractor may propose remedial work to improve the smoothness. Such proposals are subject to the acceptance of the Ministry Representative, but such acceptance does not imply that the proposed remedy will be successful, and does not reduce the Contractor's responsibility for meeting the acceptance requirements. Grinding may be acceptable, but an overlay may be required. Only one attempt may be made to improve smoothness, and this must be completed within ten (10) calendar days

SECTION 502

from the time the Contractor receives notification from the Ministry Representative of the original smoothness test results for that Sub-Lot.

Following any attempt to improve the smoothness of a Sub-Lot or Sub-Lots, the Ministry Representative will retest the Sub-Lot or Sub-Lots, and the new results will replace the previous data for the purposes of determining acceptance and payment.

No payment will be made for any material, equipment or manpower used to improve, or attempt to improve, smoothness.

TABLE 502-J – PAYMENT ADJUSTMENTS FOR SMOOTHNESS

Lot IRI (m/km)	Payment Adjustment Per Lot	
	Standard	Alternate
≤ 0.80	+\$2,000	+\$2,000
> 0.80 to ≤ 0.90	+\$1,000	+\$2,000
> 0.90 to ≤ 1.00	+\$500	+\$2,000
> 1.00 to ≤ 1.10	+\$200	+\$1,000
> 1.10 to ≤ 1.20	0	+\$500
> 1.20 to ≤ 1.30	-\$100	+\$250
> 1.30 to ≤ 1.40	-\$250	0
> 1.40 to ≤ 1.50	-\$600	-\$300
> 1.50 to ≤ 1.60	-\$1,400	-\$300
> 1.60 to ≤ 1.70	-\$2,000	-\$750
> 1.70 to ≤ 1.80	-\$3,000	-\$750
> 1.80 to ≤ 1.90	REJECT	-\$1,500
> 1.90 to ≤ 2.00	REJECT	-\$2,500
>2.00	REJECT	REJECT

502.57.09 Smoothness Deficiencies – Smoothness deficiencies (bumps and dips) less than 12 mm over 3 m will not have remedial work required. Individual deficiencies between 8 mm and 12 mm over 3 m will result in a \$200.00 penalty for each occurrence. Deficiencies exceeding 12 mm over 3 m will require remedial work.

502.58 Overlays as a Corrective Measure – If an overlay is used as a corrective measure on a defective Lot or Sub-Lot, the overlay thickness will be subject to the acceptance of the Ministry Representative, but shall not be less than 40 mm. In all other respects, the whole overlay will be subject to the same

ASPHALT PAVEMENT CONSTRUCTION (EPS)

specifications as the pavement being overlaid. Where an overlay is used as a corrective measure in any lane, adjacent lanes shall also be overlaid whether acceptable or not.

Whether the overlay is applied as a corrective measure or is placed over otherwise acceptable pavement in order to match an adjacent lane, acceptability and payment will be determined as follows:

- acceptability, and eligibility for either positive or negative payment adjustment, will be determined entirely on the results of testing and observations conducted on the overlay, regardless of test results that have been obtained on the underlying, overlaid Lift of pavement; but

- the payment quantity, for application of the Unit Prices for asphalt pavement, and the quantity, to which any payment adjustment is to be applied, will be derived from the tonnage of mix in the underlying, overlaid Lift.

PART G – APPEAL TESTING

502.60 Time Limits For Appeal of Test Results –

To appeal any test results, the Contractor shall serve written notice of appeal to the Ministry Representative, within the following time period after receipt of the applicable test results:

- For Density, Gradation and Asphalt Content, within two (2) working days; and
- For Segregation, Smoothness and Application Rate, within three (3) working days.

502.61 Appeals of Density, Asphalt Content and Gradation –

The Contractor may appeal the results of acceptance testing for density, asphalt content and/or aggregate gradation for any Lot only once. Appeals will only be considered if quality control results support an appeal and can be presented.

Quality control test results for density which are provided to the Ministry Representative subsequent to the Contractor's receipt of the quality assurance test results for that Lot will not be considered (when evaluating evidence) for an appeal. The appeal shall be for all tests within the Lot, and there will be no appeal allowed for single tests within a Lot.

Any attempt to improve density on the appealed Lot after the Ministry Representative has tested the Lot for acceptance shall void the appeal and the original test results will apply.

The Ministry Representative will arrange for an independent testing laboratory to perform the appeal testing. The personnel employed or testing laboratory retained by the Contractor for quality control testing on the project will not be used for appeal testing.

SECTION 502

The appeal testing laboratory shall hold current certification from the Canadian Council of Independent Laboratories (CCIL) (<http://www.ccil.com/>) under both the Asphalt Laboratory and Aggregate Laboratory Certification Programs, and at least one technician in the asphalt laboratory shall hold current certification under the Asphalt Technician Certification Program.

502.61.01 Density Appeals – For density appeals:

- the Contractor shall, within two (2) working days of filing the appeal and in the presence of the Ministry Representative, take five (5) cores samples from random locations
- the Contractor shall then deliver new core samples to the Ministry Representative;
- the Ministry Representative shall deliver the core samples and the companion loose mix samples from the appealed Sub-Lots to the appeal testing laboratory.
- the appeal agency shall determine the MTD from the companion sample and the densities of the cores and report the results to the Ministry Representative and the Contractor.
- the original core test results will be discarded and a new sample mean will be obtained from 5 random cores. The appeal agency shall prepare new briquette densities from the previously taken companion samples as per Appendix 2.

502.61.02 Asphalt Content and Gradation Appeals

– For asphalt content and gradation appeals

- the party who has possession of the companion loose mix samples shall deliver them to the appeal testing laboratory.
- the appeal agency shall prepare three new samples from the companion sample and determine the AC contents and gradations, average the results, and report all results to the Ministry Representative and the Contractor.

ASPHALT PAVEMENT CONSTRUCTION (EPS)

- the original test results will be discarded. A new sample mean for three new test results will be determined using the companion samples and will be used for acceptance and payment adjustments.

502.62 Smoothness Appeals – The Contractor may appeal acceptance test results of a Lot only once.

The Ministry Representative will perform, and the Contractor will be given the opportunity to witness, the appeal testing and the new results will be binding on the Contractor and the Ministry.

502.63 Segregation Appeals – Appeals of segregation ratings will first be handled by a joint review with the Contractor. If consensus cannot be reached then the Ministry Representative shall engage the Joint Committee, comprised of representatives from the Ministry and B.C. Road Builders, to assess the area(s) in question.

502.64 Application Rate Appeals – Appeals of application rate will be handled by a joint review with the Contractor and Ministry Representative. If the issue cannot be resolved, the issue will be resolved through the dispute resolution provisions of the Contract General Conditions.

502.65 Application of Appeal Testing Results – The appeal test values, thus determined, in all cases, will be binding on the Contractor and the Ministry.

502.66 Payment for Appeal Testing – If the new results indicate a change in the payment adjustment in the Contractor's favour, then sampling and testing costs incurred during the appeal procedures for that Lot will be borne by the Ministry.

If the new results verify that any payment reduction or rejection remains valid for that Lot, then the costs of testing (plus 10% mark-up) incurred during the appeal procedure will be charged to the Contractor.

SS 502 APPENDIX 1

QUALITY CONTROL REQUIREMENTS AND GUIDELINES

1.01 GENERAL

The Contract requirements for preparing, submitting and adhering to the paving components of a Quality Control Plan are specified in SS 502.04. This Appendix titled “Quality Control Requirements and Guidelines” sets out the guidelines for the Contractor’s Quality Control Plan, in addition to those set out in SS 502.04 and the Special Provisions.

1.02 QUALITY CONTROL PLAN

The Contractor shall prepare and submit a Quality Control Plan for review. The Plan may be operated wholly or in part by a qualified Subcontractor or an independent organization/agency. However, the Quality Control Plan, including compliance with the Plan and its modifications, must remain the responsibility of the Contractor.

The Plan shall address all elements that affect the quality of the hot mix, hot laid asphalt pavement, including but not limited to the following:

- Purchased Materials (asphalt cement characteristics, additives, purchased aggregates, etc.)
- Aggregate production (inc. source quality, gradation, fracture, crushing procedures, stockpiling, etc)
- Calibration and Correlation of Testing Equipment (plant sensors, lab equipment, nuclear moisture/density gauges, etc.)
- Mix Design
- Asphalt Plant Mixing procedures (cold feed sampling, AC flow rate, , temperature control, records, weigh scale, etc)
- Product quality (volumetrics, EPS payment elements, etc.)
- Professional standards (joints, placing temperature, rolling procedures, etc.)

The plan shall also include the following:

- The name of the Quality Control testing agency and its proven capability to provide the specific services required for the project.
- The list of dedicated technical staff, if available, (including names, qualifications and relevant experience) and their proposed roles.
- The list of testing equipment available for project work.

The Quality Control Plan shall include the designation of specific personnel to be responsible for specific quality control duties.

- There shall be a Quality Control Manager (QCM) who will be responsible for the development and management of the Quality Control Plan. This person shall be qualified as per the requirements identified in SS 502.04.03. This individual shall also be responsible for the signing off of Quality Control Testing and Inspection records. This individual shall also be responsible for ensuring the qualifications of quality control staff, implementing and documenting any changes or improvements to the Quality Control Plan.

- There should be a designated Process Control Technician (PCT), with 5 years of related experience, who will ensure that laboratory test results and other quality control practices are used to control the quality of aggregates and other mix components, and to adjust and control mix proportions to meet the mix design(s). The PCT is responsible for ensuring that testing equipment, utilized for proportioning and mixing are calibrated and in good working order. The Plan shall describe how the PCT’s duties, including sampling methods and responsibilities are to be accomplished and documented. The Plan should also describe the criteria to be used by the PCT to correct or reject unsatisfactory materials.

- There should also be a Pavement Quality Control Technician (PQT), with 5 years of related experience, who will ensure that delivered materials meet the requirements of the specifications. In addition, the PQT shall be responsible for periodically inspecting all equipment used in placing, finishing, and compacting to assure its proper operating condition and to assure that placing, application rate, finishing, joint construction, and compaction is in conformance with this specification and the contract requirements.

1.03 CONTRACTOR’S RECORD OF QUALITY CONTROL TESTING

Test results should be made on specified forms or charts immediately after completion of each test. These test results are to be made available to the Ministry Representative upon request.

Records of gradation control, both during aggregate production and also during the asphalt mixing operation, should be kept on the form H-295 - Mechanical Analysis of Aggregates.

SECTION 502

1.04 MATERIAL APPLICATION RATE

The Contractor shall control the Material Application Rate by monitoring the amount of asphalt mix delivered to the road against the area covered by checking the application rate minimally every ten loads.

The Contractor shall advise the Ministry Representative in writing on an ongoing basis of the application rate.

1.05 DENSITY

The Contractor should take core samples to determine actual pavement density. At the start of paving, the Contractor should take a minimum of two pavement cores from each Sub-Lot. The Contractor may employ a nuclear densitometer (or moisture/density gauge) to ensure intermediate density control. Two nuclear densities may be determined for each Sub-Lot, based

ASPHALT PAVEMENT CONSTRUCTION (EPS)

on job mix densities obtained from the most recent plant briquettes.

1.06 OTHER QUALITY CONTROL PROCEDURES

The Contractor may initiate other Quality Control procedures as necessary for ensuring production of a quality product and include them in the Quality Control Plan. Procedures may also be introduced after the start of work as necessary as amendments to the Quality Control Plan.

1.07 QUALITY CONTROL TESTING FREQUENCY

Minimum test frequencies Guidelines for Quality Control are described in the following table:

TABLE 502 Appendix 1-1 – GUIDELINES FOR MINIMUM TEST FREQUENCIES

	ASTM Test	*Minimum Frequency
Tests During Aggregate Production	C 136, Dry Sieve Analysis of Aggregate or C 117 Sieve Analysis of Aggregates by Washing (<i>Modified for Field Lab with drying done over a hotplate or similar heating element</i>)	- Split Stockpiles: 1 for each stockpile for every 2 hours of production. - One main stockpile: for every 300 tonnes. - Blend Sand: 1 for every 100 tonnes during stockpiling. - Natural filler: 1 for every 50 tonnes during stockpiling.
	D 5821 Determining the Percentage of Fractured Particles in Coarse Aggregate	Every second coarse aggregate sieve test.
	C 117 Sieve Analysis of Aggregates by Washing (<i>Modified for Field Lab</i>)	1/shift on reduced sample obtained from combined samples from the crusher
Asphalt Products Tests	Tack and Prime	Contractor's option.
Tests During Asphalt Plant Mixing	C 136, Dry Sieve Analysis of Aggregate	1 of combined aggregate (off the belt) every 300 tonnes.
	C 566 & D 2216, Moisture Content	Aggregate: 2 tests/Lot Asphalt mix: 1 on first Sub-Lot and every second day.
	C 117 Sieve Analysis of Aggregates by Washing (<i>Modified for Field Lab</i>)	1/shift on reduced sample obtained from combined samples from the plant cold feed
	D 5581 Resistance to Plastic Flow Using Marshall Apparatus.	One set of three briquettes for 1,200 tonnes or Lot, whichever is less.
	D 6307 Asphalt Extraction, Ignition Method	One/Lot.
	D-5 Penetration of Bituminous Materials	One per Manufacturer's Batch. Samples should be taken for every 3000 tonnes of mix production
	D 2171 Viscosity	Contractor's Option
	D 2041 Maximum Theoretical Density	<u>One per sub-lot</u>
Test During Asphalt Paving for Density Testing	AASHTO T 245-97 Resistance to Plastic Flow Using Marshall Apparatus	One 15 kg sample for every Sub-Lot or minimum 1/day for field testing
	Core Samples	At start, two cores for each Sub-Lot. After rolling pattern established, only one core for each Sub-Lot. All Marshall mix cores to be a minimum of 100 mm diameter; Superpave mixes shall require minimum 150 mm diameter cores

* These are the minimum frequencies and the Contractor is responsible to assess the need to increase testing frequency, where aggregate source is not uniform or any other condition exists that may warrant it. QC frequencies may be reduced below this level, subject to the Ministry Representative's authorization, should the Contractor's QC Plan be proven very effective.

SS 502 APPENDIX 2

OBTAINING AND PREPARING

LOOSE MIX SAMPLES

1. Three (3) samples per Sub-Lot shall be obtained by the Contractor (generally from the paver augers), at locations and times chosen by the Ministry Representative. The first sample shall be used by the Contractor for Quality Control, the second sample by the Ministry for Quality Assurance, with the third retained by the Ministry for potential appeal testing.
2. The samples taken shall meet the requirements of ASTM D 979 Sampling of Bituminous Mixtures, Table 1, Size of Sample.
3. The sample size shall be reduced to required laboratory sample size for Marshall and Superpave gyratory briquettes, asphalt content and hot mix gradation determination as outlined below:
 - a) The sample shall either be reduced using a Riffle splitter or shall be quartered into four approximately equal portions. The two diagonally, opposite quarters shall be combined resulting in two samples. Identify and designate one of the samples as the Quality Companion Sample and set aside. Identify and designate the other resulting sample as the Quality Control Sample. Use the Quality Control Sample for testing.
 - b) The Quality Control Sample shall be weighed to ensure that the sample so obtained meets the minimum mass required for the ignition test. If the sample does not meet the minimum mass requirements, then the additional materials will be obtained and added to the Quality Control Sample from the Companion Sample. This will be achieved by quartering the Quality Companion sample and adding one quarter of the Quality Companion Sample to the Quality Control Sample.
 - c) This process is to be repeated for each sample to provide the Quality Acceptance and Appeal Samples.
4. The third sample for appeal purposes shall be set aside and retained in a Contractor-supplied, suitable container labeled with sample location, date sampled, and project information.
5. The Contractor shall deliver the QA and appeal samples to the Ministry Representative for storing.
6. If a sample is taken from the mat, The areas sampled shall be filled with mix immediately after sampling, and shall receive the same compactive effort as the rest of the mat.

SS 502 APPENDIX 3

BLANK AGGREGATE SAMPLE PREPARATION

1. Blank aggregate samples replicate the Job Mix Formula design aggregate gradation, without asphalt cement and are used to correlate the Ministry, Contractor, and appeal lab ignition ovens.
2. Twenty-four (24) blanks are required, each weighing 1900 ± 1 gram. This size approximates the size of the mix samples, less the asphalt cement, that will be used for the project's daily Quality Assurance testing.
3. The blanks shall be prepared from bulk aggregate samples (i.e. coarse aggregates, fine aggregates, blend sand, etc. samples) that were produced from the same sources and are the same materials as the aggregates that will be used for the project and have been designated in the Mix Design. 50 – 60 kg of material will be required.
4. The bulk aggregate samples shall first be dried, and then thoroughly blended at the design cold feed percentages $\pm 1\%$.
5. The blended material shall then be sieved into each of the individual sieve sizes designated in the Mix Design.
6. The aggregate blanks will then be made up from the sieved material, adding proportions from each individual sieve to conform to the estimated dry aggregate JMF gradation within the tolerances specified below.
7. Masses of aggregate added shall be within the tolerances specified in Table 502 Appendix 3.
8. Samples shall be sealed in cans or bagged in moisture-proof heavy gauge plastic bags, and labeled with the project number, blank number, the preparation date, and a JMF identification number.

Table 502 Appendix 3 Sieve Size

Sieve Size	Cumulative Mass Tolerance (g)
Pan	0.1
0.075	0.1
0.15	0.1
0.3	0.1
0.6	0.1
1.18	0.1
2.36	0.1
4.75	0.1
9.5	0.7
12.5	2
16	3
19	6
25	13
37.5	45

SS 502 APPENDIX 4

IGNITION OVEN CORRELATION PROCEDURE

1. Asphalt Mix samples are prepared and burned to determine the effect each oven has on the mix.
2. The Contractor and the Ministry shall each prepare three (3) Asphalt Mix calibration samples by adding AC (provided by the Contractor from the supplier and batch that will be used on the project) to randomly selected aggregate blanks prepared by the Contractor in accordance with SS 502 Appendix 3.
3. AC shall be added to the blanks at the proportion specified in the accepted JMF, within a tolerance of ± 0.1 g.
4. Each party shall burn their mix calibration samples in their ignition oven in accordance with ASTM D 6307 to determine their calibration factor.
5. The calibration factors determined above shall be compared and the inter-laboratory correlation determined.
6. Correlation between the Contractor's lab and the Ministry lab shall be completed, reviewed and mutually acceptable to the Contractor and the Ministry Representative a minimum of one (1) working day prior to placement of any mix.
7. In the event of an appeal on AC Content, the appeal laboratory shall also prepare and burn calibration samples to determine their oven calibration factor.
8. Results from testing of any asphalt mix shall report the measured AC Content and the corrected AC Content after applying the laboratory calibration factor.

SECTION 503

BASE PREPARATION AND BASE PROCESSING

503.01 Base Preparation - The work shall consist of shaping and compacting the existing granular base course to the designated grade and cross-section.

The existing base course material shall be watered, graded and compacted to provide a non-segregated, tightly-knit surface which conforms to the line, grade and cross sections shown on the Drawings or staked by the Ministry Representative to an accuracy of ± 10 mm.

If necessary, the existing surface shall be scarified and bladed to achieve this. No imported materials are to be incorporated into the work, except where failed areas have to be backfilled.

a) Failed Areas - Where a failed area is present in the existing base, the Contractor shall excavate and dispose of the material, all as directed by the Ministry Representative. The area shall be backfilled using crushed granular base or surfacing aggregate or road-mix as directed by the Ministry Representative and compacted to the same density as the rest of the base course.

b) Compaction - If watering is required to attain compaction or for any other reason, it shall be applied uniformly from a distributor of the pressure type, equipped with a spray bar mounting nozzles similar to those used on asphalt distributors. Splash plate type distributors or those equipped with spray bars that eject fine streams of water will not be permitted. The distributor must be provided with a satisfactory means for accurately measuring the quantity of water sprayed. If the Ministry Representative so requires, the measuring equipment shall be calibrated under the Ministry Representative's inspection.

The final surface of the base course shall be compacted to a minimum 100% of the laboratory density obtained by the current ASTM test method D 698.

c) Surplus Aggregate - All surplus loose aggregate arising from the base preparation shall be bladed clear

into windrows on the shoulder for later incorporation into the shouldering aggregate or bladed to the side slope and trimmed, as directed by the Ministry Representative.

d) Payment - Payment for Base Preparation will be at the unit prices bid in the Schedule of Approximate Quantities and Unit Prices per square metre for the area actually prepared and shall be full compensation for scarifying done to a maximum depth of 40 mm, blading, shaping, trimming, compacting, finishing and maintaining the granular base to the required line, grade, cross-section and density.

Payment for supply of material used for backfilling and compaction of failed areas will be at the unit price bid in the Schedule for the material used. Payment for excavating and disposing of the material from the failed areas will be by Order for Extra Work.

Payment for Water Applied to Roadway will be at the unit price bid per kilolitre for the actual quantity applied to the road and shall be full compensation for everything furnished and done to supply, haul and apply water.

503.02 Base Processing - Where, in the opinion of the Ministry Representative, the base is so deformed, rutted or unsuitable, that it cannot be adequately prepared for priming under the provisions for base preparation, the Ministry Representative shall order in writing how it shall be processed. This work shall be carried out on an Order for Extra Work basis.

Payment will not be made for superintendence, provision or placement of barriers, lights or other equipment which should normally be provided and available for the general performance of the contract.

THIS PAGE IS LEFT INTENTIONALLY BLANK

SECTION 504

PAVEMENT DRAINAGE

DESCRIPTION

504.01 Scope - This Section covers the provision of pavement drainage with the construction of necessary asphalt curbing and drainage outlets using cast iron catch basins or asphalt spillways together with pipe or paved outfalls. Concrete curbs, concrete and corrugated steel catch basins, cast iron grates and frames where applicable are specified by Section 582.

MATERIALS

504.11 Materials

- a) Unless otherwise specified the Ministry will supply f.o.b. the Contractor's job site yard or the Ministry's yard or other location as indicated in the Special Provisions or Purchase Order the following materials:
- Cast Iron Catch Basin Box and Adaptor plate (Drawing SP582-02.05).
 - Cast Iron Catch Basin Grates (Drawing SP582-05.02).
 - 200 mm Nominal diameter Corrugated Galvanized Steel Pipes, Bends and Connectors (Section 320).
- b) The Contractor shall provide and/or fabricate as required:
- i) All strap iron binding hoops, angle iron pipe supports, brackets, bolts and studs or other hardware not provided by the Ministry.
- ii) All other building or construction materials that may be required to construct the outlets according to the intent of this Section.
- iii) Asphalt mix required for the work with payment to be made in accordance with SS 504.93.

CONSTRUCTION

504.31 Asphalt Curbs

504.31.01 Integral Asphalt Curb - Where specified in the Contract Documents, asphalt concrete curb integral with the asphalt concrete highway pavement shall be constructed to the dimensions indicated on Drawing SP504-01.

504.31.02 Machine-Laid Asphalt Curb - Where specified, machine laid (extruded) asphalt concrete curbs shall be constructed in accordance with Drawing SP504-01 and as follows:

- i) The type of curb to be placed (Type "A" or Type "B") will be as specified or as determined by the Ministry Representative.
- ii) Prior to construction of the curb, the affected pavement area shall be dry and cleaned of loose or deleterious materials. A tack coat of liquid or emulsified asphalt determined by the Ministry Representative or specified in

the Special Provisions or Purchase Order shall be uniformly applied at a rate of 0.25 to 0.5 ℓ/m^2 , to a width 0.1 m wider than the proposed curb.

iii) The production and transportation of asphalt mix for curb construction shall be in accordance with SS 501 and SS 951 and shall meet the requirements for Class 1 Fine Mix.

iv) The machine for constructing the curb shall be self-propelled extrusion-type equipment with a material hopper, distributing screw and adjustable curb forming devices capable of placing and compacting the asphalt mix to the required alignment, grade and cross-section in an even homogeneous manner free of surface defects. The asphalt concrete mix shall be handled to provide a curb meeting the applicable density requirements of Section 501 and the curbing equipment shall be operated in a manner that ensures a smooth, uniform finished curb alignment. Where handforming of curb is required, the finished curb shall conform to all dimension, alignment, density and finish requirements for machine-laid curb.

504.32 Location of Drainage Outlets - On completion of pavement and curb construction and in conjunction with the installation of any precast concrete barriers, the Contractor shall install or construct drainage outlets at the low point of curves in the vertical alignment and at such other locations designated by the Ministry Representative.

Note: The exact low point on the pavement may be determined by allowing water to flow along the surface to the actual lowest point on the pavement adjacent to the curb or barrier. This low point shall be clearly marked on the pavement.

504.33 Excavation - At the locations designated by the Ministry Representative, the asphalt pavement and any curbing shall be accurately cut away and the highway shoulder excavated to the dimensions consistent with the installation of Cast Iron Catch Basins (Drawing SP504-03) or the construction of Asphalt Spillways (Drawing SP504-02). The excavation shall, as nearly as possible, have vertical sides and shall be so done as to cause minimum disturbance of the adjacent compacted base and pavement structures. The outside dimensions of the excavation shall be the smallest compatible with the efficient construction of the drainage facility, as any excess or irregular excavation will be required to be repaired with asphalt mix.

Where applicable, appropriate trench excavation shall be performed to permit the installation and embedment of outlet pipe and associated fittings. Excavation for installation and embedment of outlet pipe shall be considered incidental to the rate bid for pipe installation.

504.34 Drainage Outlets

504.34.01 Cast Iron Catch Basins - Bedding and surrounding mortar for catch basins shall be composed of one part Portland cement to three parts clean well-graded fine aggregate mixed to proper consistency.

Bedding shall be a minimum of 125 mm thick to permit accurate setting of the catch basin in mortar at the correct level true to alignment with curbing, barrier or pavement edge as shown on Drawing SP504-03. After securely fixing the adaptor, watertight gasket and connecting pipe, the catch basin shall be surrounded with mortar to the full perimeter of the excavation, and the mortar well tamped and worked around the connecting pipe for 300 mm from the side of the catch basin.

The mortar shall be allowed to set prior to backfilling and further work.

504.34.02 Asphalt Spillways - Asphalt spillways shall be constructed to the general dimensions shown on Drawing SP504-02 with the necessary handforming in accordance with SS 504.31.02 (iv).

504.34.03 Pipe Outfalls General - Except where paved outfalls are specified, corrugated galvanized metal outlet pipes of the required diameter shall be installed, as shown generally on Drawing SP504-03. Should the fill material preclude pipe embedment, the pipe shall be secured to the slope by dual angle iron posts placed at 3 m intervals, as shown. The pipe shall be similarly secured at the bend at the base of the slope and at a point approximately 150 mm from its outlet.

The pipe trench shall be backfilled with excavated material as may be directed by the Ministry Representative and the fill thoroughly compacted.

Riprap of 200 mm minimum dimension shall be placed at the pipe outlet as shown on Drawing SP504-03.

504.35 Dishing, Spillways and Completion - The asphalt pavement adjacent to the drainage outlet shall be constructed to the profile and cross-sections indicated for the type of outlet being installed. The asphalt pavement surface shall be so shaped as to channel all collected water to the outlet orifice and no ridges or other obstructions shall be left which may impede the flow of water to the drainage outlet.

The asphalt paving mix shall be compacted to the density specified by the Ministry Representative to provide an integral and impervious drainage area. Where the asphalt pavement abuts a cast iron catch basin box, the contact face of the box shall be painted with liquid or emulsified asphalt as specified in SS 501.23.15 prior to placing the asphalt concrete.

On completion, the area shall be cleared and cleaned up to the satisfaction of the Ministry Representative.

MEASUREMENT

504.81 Pavement Drainage Outlets - Pavement drainage outlets will be measured per EACH of the type specified.

504.82 Corrugated Metal Pipe - Corrugated metal pipe will be measured by the METRE along its centre line as installed.

504.83 Asphalt Concrete Mix - Unless otherwise specified, asphalt concrete mix used to form drainage aprons, curbs, spillways and outfalls will be measured by the TONNE.

504.84 Asphalt Curb - Asphalt curb will be measured by the METRE.

PAYMENT

504.91 Pavement Drainage Outlets - Payment for the installation of PAVEMENT DRAINAGE OUTLETS will be at the Contract Unit Price for each complete outlet of the type specified. The Contract Unit Price shall be full compensation for taking delivery of cast iron basins, boxes and grates; excavation (see SS 504.33); provision of all materials required for setting basins to correct grade including cement mortar; backfill and compaction; spreading, shaping and compaction of asphalt concrete aprons and spillways; provision and setting of riprap at the outfall and all labour, materials, tools, warning signs, barriers and superintendence required to complete the installation of the drainage outlet.

504.92 Corrugated Metal Pipe - Payment for CORRUGATED METAL PIPE will be at the Contract Unit Price per metre. The Contract Unit Price shall be accepted as full compensation for taking delivery and installation including all necessary transport of components, excavation and backfilling; provision of posts, brackets, hoops and hardware; labour for connecting and securing pipe fittings, compaction, superintendence, lights, warning signs, barriers and all other things or services necessary for the proper installation of the pipe.

504.93 Asphalt Concrete Mix - Unless otherwise specified, payment for ASPHALT CONCRETE MIX used to form drainage aprons, curbs, spillways and outfalls will be at the Contract Unit Price per tonne.

504.94 Asphalt Curb - Payment for ASPHALT CURB will be at the Contract Unit Price per metre of the appropriate curb type placed. The Contract Unit Price shall include the formation of offset curb alignment at drainage outlets in accordance with SS 504.31.

DRAINAGE CURBS
TYPE-A, TYPE-B & INTEGRAL ASPHALT

SP504-01

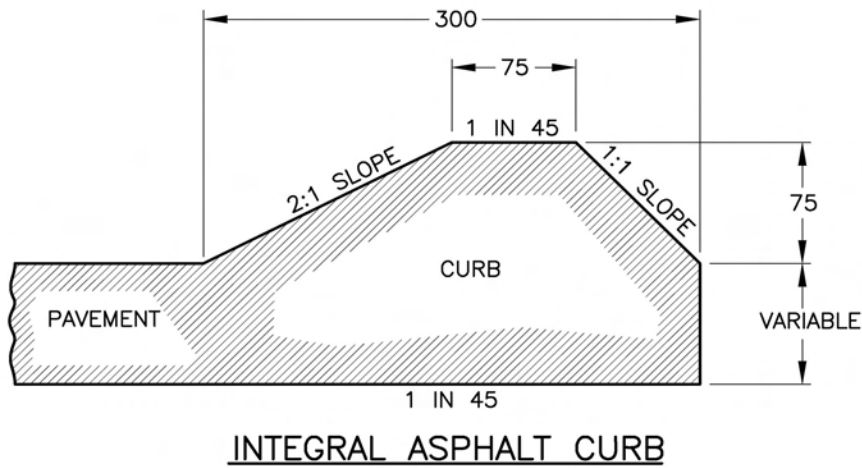
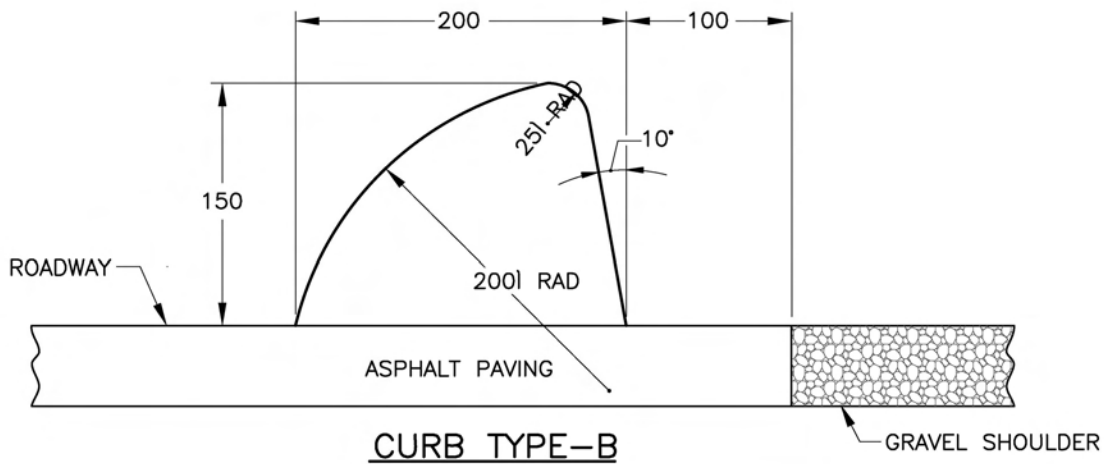
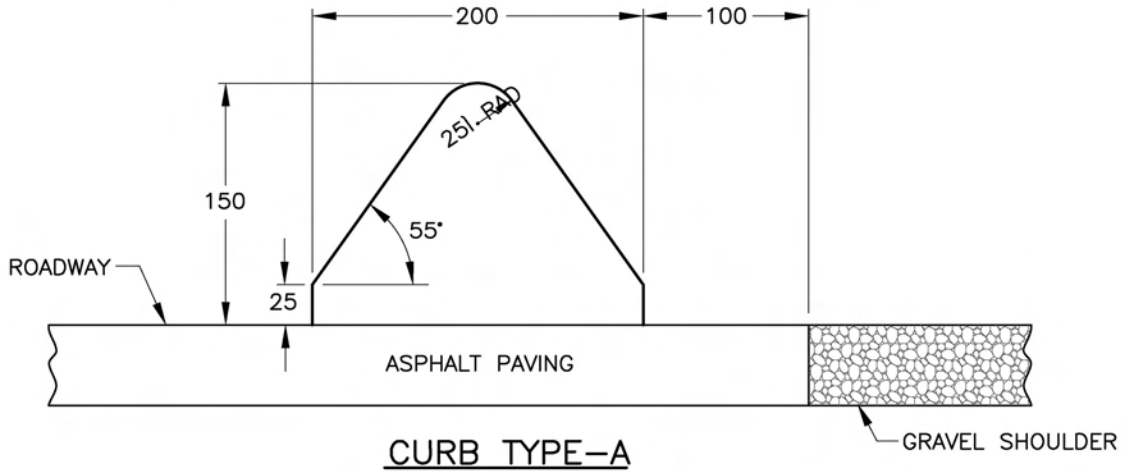

NOT TO SCALE

ALL DIMENSIONS ARE IN MILLIMETRES UNLESS OTHERWISE NOTED

INSTALLATION OF ASPHALT SPILLWAYS

SP504-02

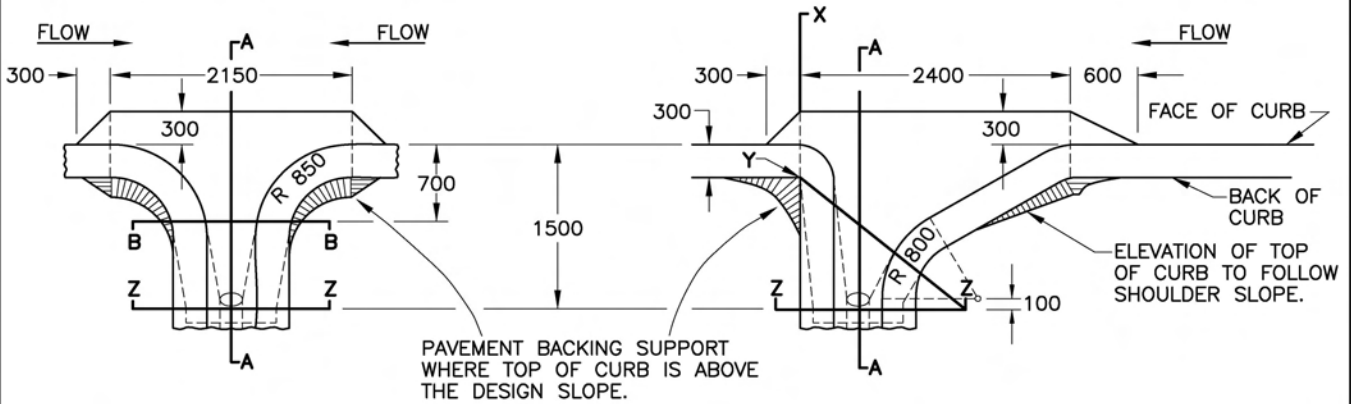

PLAN AT SAG

PLAN ON GRADE

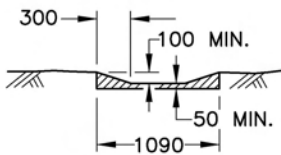

SECTION B-B

COMMON TO PAVED OR PIPED OUTFALL AT "SAG" SPILLWAY

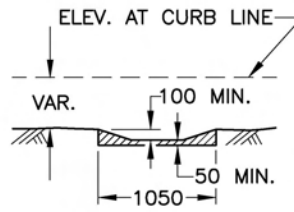

SECTION Z-Z FOR PAVED OUTFALL

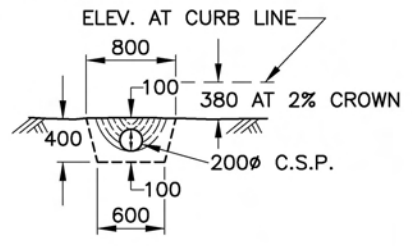

SECTION Z-Z FOR PIPE OUTFALL

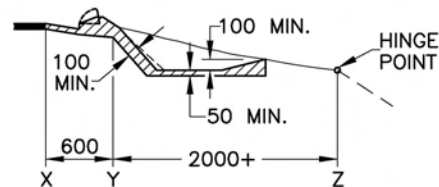
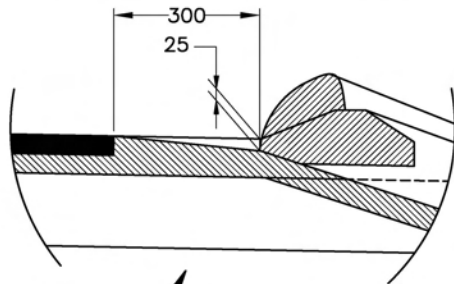

SECTION X-Y-Z

COMMON TO PAVED OR PIPED OUTFALL AT "ON GRADE" SPILLWAY

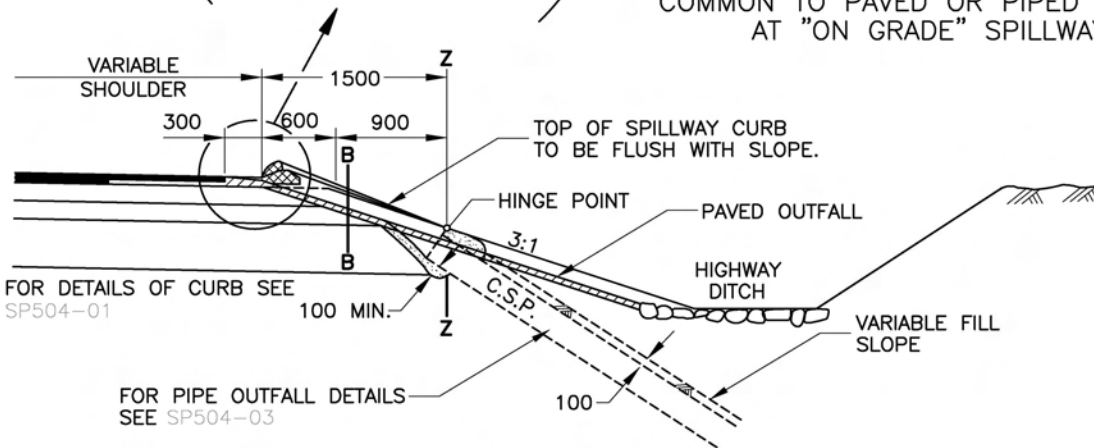

SECTION A-A

NOT TO SCALE

ALL DIMENSIONS ARE IN MILLIMETRES UNLESS OTHERWISE NOTED

INSTALLATION OF CURB, BARRIER AND CAST IRON CATCH BASIN

SP504-03

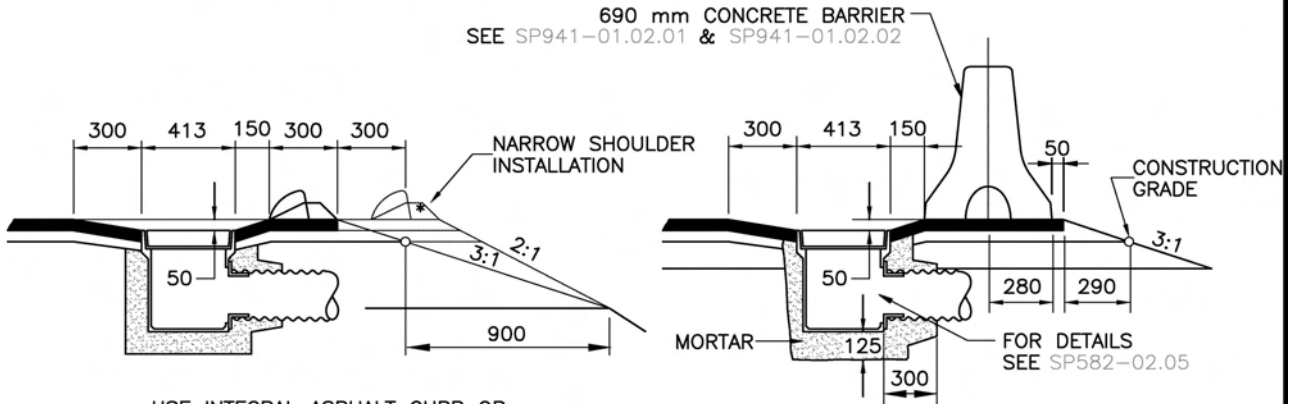

USE INTEGRAL ASPHALT CURB OR TYPE-B CURB (SEE SP504-01)

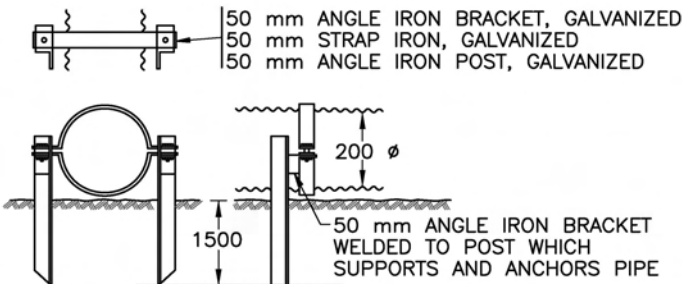
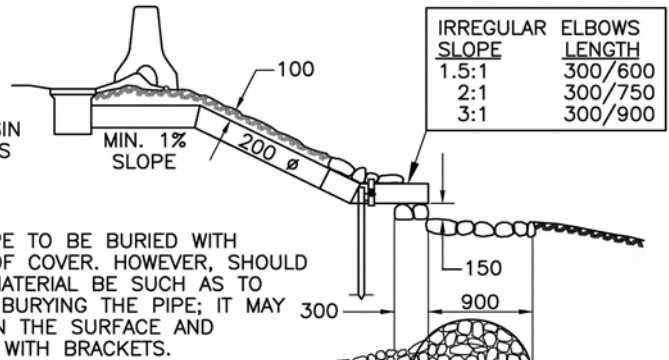
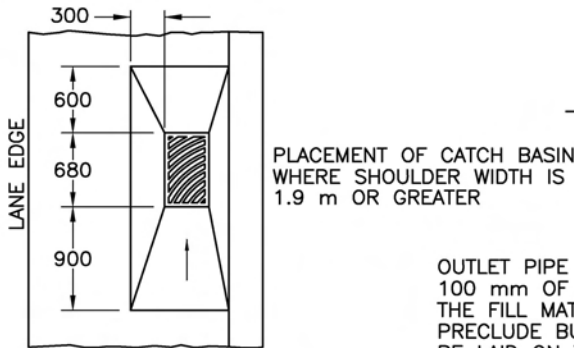
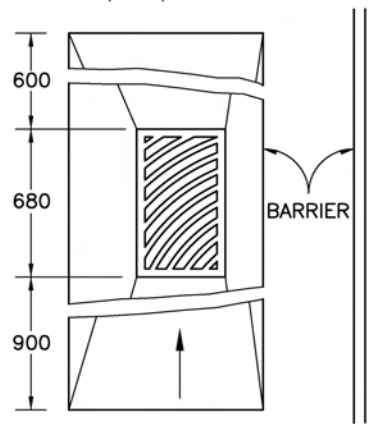
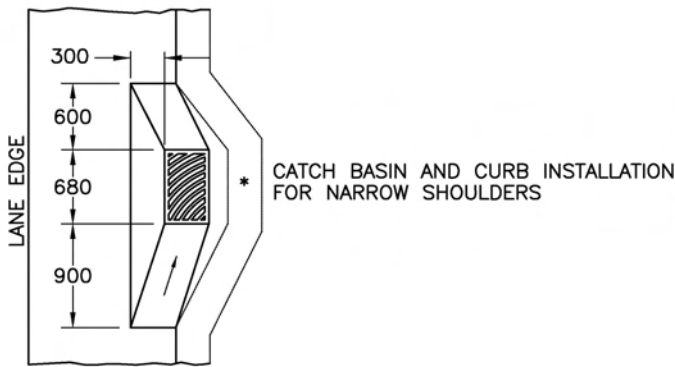

DETAIL OF PIPE, ANCHOR BRACKETS AND POSTS

POST AND BEAM GUIDE RAIL

NOT TO SCALE

ALL DIMENSIONS ARE IN MILLIMETRES UNLESS OTHERWISE NOTED

THIS PAGE IS LEFT INTENTIONALLY BLANK

SECTION 507

PRODUCTION AND STOCKPILING OF ASPHALT MIX

507.01 General - This Section covers the supply of aggregate, mixing it with a specified asphalt material in a central plant and placing the produced mix in a stockpile.

507.02 Aggregate

a) The Contractor shall supply aggregate with gradation wholly within the limits listed in Table 507-A when tested in accordance with ASTM C 117 (Wash Test).

Once a crushed aggregate gradation has been accepted, the maximum permissible variation of the mean of any four consecutive tests from the accepted gradation curve shall be within the limits specified in Table 507-B.

Should there be a substantial change in the type of aggregate exposed as the work proceeds, the Ministry Representative may authorize a change in the mean gradation.

b) A minimum of 50% by count of all aggregate particles retained on the 4.75 mm sieve shall have at least one fractured face or shall be naturally angular with sharp edges (SS 202, Appendix 1). If this requirement cannot be met for a specified crushed aggregate type then the Contractor shall, at no additional charge, crush aggregate to the next smaller size or such intermediate size as the Ministry Representative may direct in order that the crushed granular aggregate shall meet the requirement.

c) All aggregates shall be free from coatings of clay, silt or other objectionable matter and shall contain no clay lumps or other aggregations of fine-grained materials.

d) Crushed aggregate shall conform to the following requirements:

- The sand equivalent value in accordance with ASTM D 2419 shall not be less than 40.
- The degradation factor in accordance with ASTM D 6928 shall be not more than 20
- In the absence of satisfactory performance records for a particular source of aggregate, its soundness shall be tested according to ASTM C 88. Aggregate so tested shall be considered unsatisfactory if the loss after five cycles exceeds 20% for coarse aggregate or 25% for fine aggregate.

e) For testing purposes, fine aggregate shall be all mineral matter passing the 4.75 mm sieve including mineral fillers. It shall consist of natural and/or manufactured material derived by crushing stone, slag or gravel.

f) Mineral filler shall:

- consist of all mineral matter passing the 0.425 mm sieve.

- be dry, free from organic matter, clay particles or lumps.
- be non-plastic when tested in accordance with ASTM D 423 and ASTM D 424.

g) Mineral dust shall consist of all mineral matter passing the 0.075 mm sieve.

507.03 Asphalt Material

- a) The type of asphalt material to be used will be specified in the Contract's Special Provisions.
- b) Normally the Ministry will supply the Liquid Asphalts

TABLE 507-A GRADATION REQUIREMENTS FOR AGGREGATE

SIEVE SIZE (mm)	PERCENT PASSING (BY MASS)	
	PATCH MIX	PAVING MIX
19.0	---	100
16.0	---	100 - 92
13.2	---	100 - 80
9.5	100	90 - 65
4.75	85 - 55	75 - 45
2.36	65 - 40	60 - 30
1.18	50 - 25	45 - 20
0.300	30 - 15	25 - 10
0.150	18 - 8	17 - 5
0.075	12 - 5	9 - 2

TABLE 507-B MAXIMUM PERMISSIBLE VARIATION OF CRUSHED AGGREGATE GRADATION FROM THE GRADATION CURVE

SIEVE SIZE	VARIATION LIMITS % PASSING
4.75 mm and larger	± 5
1.18 mm to 4.75 mm	± 3.5
0.300 mm to 1.18 mm	± 2
0.075 mm to 0.300 mm	± 1

SECTION 507

PRODUCTION AND STOCKPILING OF ASPHALT MIX

or High Float Emulsified Asphalts f.o.b. the Contractor's Plant site.

c) Should the Contractor be required to supply a particular type of asphalt material, such shall meet the requirements of SS 952.

507.04 Mix Design

a) Unless otherwise specified, the Ministry will carry out the Asphalt Mix design with the aggregate supplied by the Contractor.

b) At least seven days prior to commencement of mixing, the Contractor shall submit the following to the Ministry Representative:

- A 50 kg sample of aggregate which is representative of the aggregate to be used on the project.
- If available, a 30 kg sample of plant produced asphalt mix whose gradation is deemed to be representative of the gradation of the aggregate to be used on the project.
- When the Contractor is to supply the asphalt material, a 5 ℓ sample of the type of asphalt to be used on the project.

c) Once the design grading curve is established, the maximum permissible variation will be as specified under SS 507.02(a).

507.05 Mixing Requirements

a) Mixing operations shall be performed in a mixing plant capable of producing the asphalt mix within the required specifications.

b) The maximum moisture content of the aggregate immediately prior to mixing with a liquid asphalt (MC or SC) shall not be over 2% by mass of dry aggregate.

c) Temperatures of the mix shall be generally in accordance with the limits specified in Table 507-C. Mix temperatures may be lowered to reduce the emission of "blue smoke" from the discharge chute.

d) The asphalt content in the mix shall not vary from the design asphalt content by more than 0.3 by mass of total aggregate.

e) The asphalt mix shall not contain more than 1% moisture by mass at the discharge from the plant.

f) The asphalt mix shall be uniform in appearance with all particles thoroughly coated. The mixing time will be increased if the mix is not completely coated with asphalt.

g) The Ministry reserves the right to adjust the asphalt content in the mix up to the maximums listed in Table 507-D.

507.06 Hauling - When the haul distance from the mixing site to the stockpile is greater than 1 km, the hauling vehicles shall be equipped with and use a tarpaulin of such size as to completely protect the asphalt mix from the

weather and inhibit premature curing of the mix by aeration.

The tarpaulin shall be double quilted canvas or other approved material treated to prevent absorption of the asphalt.

507.07 Stockpiling

a) The exact location of the stockpile site will be determined by the Ministry. The Contractor shall place the cold mix within the boundaries of the designated stockpile site.

b) The Contractor shall prepare the stockpile site, which shall be shaped to a uniform smooth surface and graded to ensure good drainage.

c) Temporary stockpiling of the mix on the ground or in storage bins will be allowed, however, the Contractor will be required to minimize the handling of the mix to prevent premature curing of the mix.

d) If conveyor belts are used for temporary stockpiling or final stockpile construction, the free fall distance from the conveyor belt to the stockpile shall not exceed 2 m.

e) If the stockpile is constructed using a front end loader or end dumping by truck, the mix shall be deposited in layers of approximately 1 m in depth.

f) Plank or protected runways shall be provided for

TABLE 507-C MIX TEMPERATURES

TYPE OF ASPHALT	ASPHALT STORAGE TEMPERATURE RANGE °C	MIX TEMPERATURE RANGE °C
SC - 250	65 - 80	60 - 80
MC - 250	65 - 80	60 - 80
HF - 500M	55 - 65	100 - 120*
HF - 1000M	55 - 65	100 - 120*
* High temperatures are used when the mix is hauled directly to the road and when dictated by high moisture in the aggregate.		

TABLE 507-D MAXIMUM PERCENT BY MASS

ASPHALT TYPE	MAXIMUM PERCENT BY MASS OF DRY AGGREGATE
SC - 250	6.0
MC - 250	6.0
HF - 500M	7.3
HG - 1000M	7.3

SECTION 507

PRODUCTION AND STOCKPILING OF ASPHALT MIX

operating equipment on stockpiles when the Ministry Representative deems them necessary to prevent contaminants being tracked onto the stockpile and to minimize consolidation of the mix.

- g)** The final stockpile shall be constructed in such a manner that height is not more than 4 m.
- h)** Mixing, hauling or stockpiling will not be permitted during periods of atmospheric precipitation.

507.08 Measurement - The asphalt mix will be measured in TONNES and the asphalt material(s) in LITRES, corrected to 15°C.

507.09 Payment - Payment for ASPHALT MIX in stockpile will be at the contract unit price per tonne, and per litre of asphalt material(s) added to the asphalt aggregate as specified in the tender form.

The unit price will be full compensation for preparing the stockpile site; supplying and heating the aggregate; heating and storing the asphalt material; mixing, hauling and stockpiling the mix.

THIS PAGE IS LEFT INTENTIONALLY BLANK

SECTION 508

GRADED AGGREGATE SEAL COAT (EPS)

PART A – GENERAL

508.01 Preliminary and General - This section describes the materials, equipment, professional standards and the end product requirements for the construction of graded aggregate seal coats. This section shall be read and construed together with all applicable Standard Specifications for Highway Construction. Should this Section conflict with any other Section, this Section shall be take precedence unless otherwise stated in the Special Provisions.

508.02 General Description of Work - Surface seals shall consist of the application of a selected asphalt emulsion and embedment of the selected aggregate so as to provide a new, uniformly textured surface. This surface shall be impervious to moisture, be skid-resistant and have good riding qualities. There are six classes of Graded Aggregate Seal, as specified in Table 508-A below. These include but are not limited to graded aggregate seals, a coarse or fine sand seal or any other graded aggregate surface treatment outlined in the Special Provisions of the Contract.

TABLE 508-A GRADATION LIMITS FOR GRADED AGGREGATE SEAL

Sieve size (mm)	% PASSING BY MASS by CLASS					
	A	B	C	Mod C	D	E
19	100	-	-	-	-	-
16	-	100	100	100	-	-
12.5 ¹	60-90	60-90	-	-	100	-
9.5	40-80	35-75	30-70	25 -55	30-80	100
4.75	20-60	15-50	25-45	7 - 30	25-45	0-30
0.600	0-25	0-15	5-20	0 -10	5-20	0-10
0.075	0-7	0-5	0-3	0 - 3	0-3	0-3
Ratio ² (9.5/4.75)	-	-	-	1 - 1.5	-	-

Notes:

¹ The Contractor may use either the 12.5 mm or the 13.2 mm sieve, at the Contractor's option.

² The "Ratio" is the ratio of the mass of material retained on the 9.5 mm sieve, divided by the mass of material retained on the 4.75 mm sieve.

508.03 Definitions

a) Coarse Aggregate – Coarse aggregate is defined as all material retained on or above the 4.75 mm sieve.

b) Fine Aggregate – Fine aggregate is defined as all

materials passing the 4.75 mm.

c) Mineral Filler and Mineral Dust – Mineral filler shall consist of all mineral matter passing the 0.600 mm sieve and the mineral dust shall consist of all mineral matter passing the 0.075 mm sieve.

d) Blinding Sand – Fine aggregate used as large aggregate support.

508.04 Graded Aggregate Seal General Usage

- Class A & B - Double seals on gravel highways
- Class B - Low traffic paved roads
- Class C, Mod C, & D - Major Highways
- Class E - Second seals

PART B - SUPPLY OF MATERIALS

508.11 Asphalt Materials - The Contractor shall supply the asphalt emulsion as specified in the Special Provisions which shall meet the requirements of SS 952.

Asphalt(s) to be used on surface seals may be standard rapid curing cutback asphalt; medium curing cutback asphalts; or anionic or cationic emulsions including high float emulsified asphalts. Types and grades of asphalt binder proposed for use on the Project will be specified in the Special Provisions.

The Ministry Representative may require the use of anti-stripping additives or any other materials formulated to improve the coating and adhesive properties of the asphalt binder to the cover aggregate. Instructions concerning the type of additive to be supplied and the method of incorporation with the asphalt binder will be specified in the Special Provisions.

508.12 Aggregates

508.12.01 Mineral Aggregate Supply - Mineral cover aggregate meeting the requirements described hereunder shall be supplied by the Contractor unless specifically described otherwise in the Special Provisions.

The Ministry may supply the aggregates. If the Ministry does supply aggregates, then the Ministry will supply quality control information, if available, to the Contractor. The Contractor must verify and be satisfied that the Ministry supplied aggregates will meet the quantity and quality requirements prior to submitting a bid.

508.12.02 Mineral Aggregate – Test Methods - Mineral Aggregate will be sampled and tested in accordance with the standard ASTM procedures and tests listed in Table 508-B

SECTION 508

GRADED AGGREGATE SEAL COAT (EPS)

TABLE 508-B TEST METHODS FOR MINERAL AGGREGATE

ASTM DESIGNATION	NAME OF TEST
D 75	Sampling stone, slag, gravel, sand, and stone block for use as Highway materials
C 136	Sieve Analysis of Aggregates
C 117	Wash Test of Aggregates
C 142	Clay Lumps and Friable Particles in Aggregates
D 6928	Micro-Deval
D 5821	Fracture Count on Coarse Aggregate
D 4791	Flat and Elongated Particles

508.12.03 Test Requirements - Mineral cover aggregate shall consist of clean, sound, hard, durable particles or fragments of sand, gravel or crushed stones or combination thereof; containing a minimum of thin elongated or flaky pieces. It shall be substantially free from loosely bonded aggregations, clay lumps or other objectionable matter and shall not be markedly hydrophilic in character.

The mineral cover aggregate, when tested by the methods listed in Table 508-B, shall meet the following criteria:

- a) **Clay Lumps** - Coarse aggregate shall not contain more than 0.5% by mass of clay lumps or other aggregation of fine material.
- b) **Micro-Deval** - No individual test shall have a loss factor of more than 20%.
- c) **Flat and Elongated Particles** - The percent flat and or elongated particles must be less than 10% using 4:1 ratio.
- d) **Fracture** - Contrary to ASTM D 5821, only those particles retained on or above the 4.75 mm sieve with two or more fractured faces shall be measured. The minimum % by mass, for coarse aggregate shall be as follows:
 - Classes A & B = 75%
 - Classes C, Mod C, & D = 85%
 - Class E = not applicable

508.12.04 Graded Aggregate Seal Gradation.-

.Gradations shall meet the requirements stated in Table 508-A for each Class of graded aggregate seal.

a) **Variation Limits** – For all Classes of seal except Class E, once the grading curve is established within the above limits, the maximum permissible variation of the mean of any four consecutive tests from the grading curve shall be within the tolerances specified in Table 508-C

TABLE 508-C VARIATION LIMITS

Sieve Size (mm)	Maximum Permissible Tolerance % Passing by Mass
4.75 to 19.0	± 5.0
0.600	± 3.5
0.075	± 1.0

These tolerances do not waive the requirement that the running average of four consecutive tests must be maintained at all times inside the limits specified in Table 508-A. Should the Contractor not be able to maintain the grading within the variation limits specified above they shall be required to construct a second stockpile. This does not alleviate the Contractor from consistently maintaining the grading curve within the tolerances indicated in the gradation curves.

508.12.05 Aggregate Characteristics

a) **Coarse Aggregate** Coarse aggregate shall consist of crushed stone or gravel, or a combination thereof; or materials naturally occurring in a fractured condition; or materials naturally occurring of highly angular nature or rough texture.

b) **Fine Aggregate** Fine aggregate shall be clean, hard, durable, moderately sharp, and free from coatings of clay, silt or other deleterious material and shall contain no clay balls or other aggregations of fine material. All aggregate passing the 4.75 mm sieve shall be non-plastic.

c) **Mineral Filler and Mineral Dust** Mineral filler and mineral dust shall be free from organic matter. Mineral filler shall be non-plastic.

508.12.06 Blinding Sand - The Contractor shall be responsible for the supply of blinding material meeting the requirements of Table 508-D. That portion of blinding sand aggregate passing the 4.75 mm sieve shall be non-plastic.

TABLE 508-D Gradation for Blinding Sand

SIEVE SIZE (mm)	PERCENTAGE PASSING
4.75	100
2.36	50 - 100
1.18	30 - 80
0.300	10 - 55
0.150	3 - 20
0.075	0 - 3

508.13 Graded Aggregate Seal Design - The contractor shall provide a graded aggregate seal coat design, professionally prepared by qualified and experienced

SECTION 508

personnel. For this purpose, the Contractor shall use a qualified registered member of the Association of Professional Engineers and Geoscientists of British Columbia or a qualified registered member of the Applied Science Technologists and Technicians of British Columbia.

This design shall include the asphalt emulsion application rate in litres per square metre, spray temperature and the aggregate spread rate in kilograms per square metre. The design shall be presented to the Ministry Representative for review, at least three (3) days prior to the commencement of work and at any time subsequent changes are made to these rates.

The Contractor shall submit to the Ministry Representative four litres of a representative sample of the emulsion(s) and a twenty kilogram sample of the aggregate(s) intended for use on the project. These samples shall be supplied at least three (3) days prior to the commencement of the work.

PART C – EQUIPMENT

508.20 General The Contractor shall supply plant and equipment necessary for the proper and efficient completion of the work, including clear and effective means of calibration.

508.20.01 The Ministry Representative shall have access at all times to any plant, equipment or machinery to be used on the Project.

508.20.02 If plant or equipment adjustment is necessary, it shall be done by a competent operator or mechanic or instrument repair technician, as required.

508.21 EQUIPMENT GUIDELINES – The following are guidelines and as such are not mandatory.

508.21.01 Pressure Distributor - The pressure distributor used for applying asphalt materials to consist of a fully insulated tank with a minimum capacity of 5000 ℓ, permanently and rigidly mounted on a truck or fifth wheel trailer provided with pneumatic tires and propelled by a power unit capable of maintaining a constant and uniform speed.

The pressure distributor should be provided with the following equipment:

- a) A quick opening gate in the dome.
- b) A dipstick calibrated in 20 mm increments and a calibration chart showing the volume for each 20 mm of depth, or provide the manufacturer dipstick and chart. Readily visible external depth gauge indicating the quantity of asphalt in the tank to the nearest 50 ℓ.
- c) A means of heating the asphalt material uniformly to any temperature up to 125°C and maintaining the contents constantly at any selected temperature without any local overheating.

GRADED AGGREGATE SEAL COAT (EPS)

- d) A heavy duty, industrial-type thermometer and a remote reading dial thermometer.
 - e) Rear-mounted spray bars and nozzles set parallel to the surface to be sprayed and capable of vertical and lateral adjustment. The spray bars to be capable of adjustment to provide a uniformly sprayed surface from a minimum of 0.6 m to at least 4 m width.

The spray bars to be capable of producing up to triple coverage at one pass. The feed to the spray bars must be arranged so that there is a constant circulation of hot asphalt material to the bars to ensure a uniform viscosity and constant pressure of the liquid asphalt at each nozzle both before and during spraying operations.
 - f) The feed manifolds to the spray bars to be provided with positive filtration to prevent clogging of bars and nozzles.
 - g) Rotary adjustable spray bar nozzles to be of the same type, correct size and manufacture; and set to produce uniformly fan-shaped sprays without atomization. Nozzles to be inspected daily and any nozzle having nicked or damaged edges should be replaced.
 - h) Spray nozzles to be provided with valves capable of instant full opening and positive cut-off.
 - i) A connection to a circulating pressure manifold to which a hose may be attached for a single nozzle hand-operated outlet.
 - j) A pressure pump capable of applying the asphalt material at a minimum rate of 180 ℓ per minute, per metre of spray bar.
 - k) A pressure gauge accurate to within 15 kPa and a meter calibrated in litres per minute, should be readily visible.
 - l) A fifth wheel tachometer, calibrated in metres per minute and readily visible to the operator of the distributor.
 - m) Vehicle spring "tie-downs" to prevent the change in height of the spray bars due to the reduction of the asphalt load during spraying.
 - n) Electronic distance measuring device, with print out connected to the transmission, that is capable of measuring each spray length and the total length sprayed during the day.
- 508.21.02 Mechanical Spreader** - Cover aggregate to be spread by means of an efficient, self-propelled spreader mounted on pneumatic tires and capable of continuously and uniformly spreading closely regulated quantities of crushed aggregates at the application rates selected. The loading hopper should be of such a capacity as to ensure continuous operation between dumps of aggregate. Aggregate to be transferred from the loading hopper to the front spreading device in such a manner as to ensure a uniform flow and prevent segregation of particles.

SECTION 508

The spreading mechanism to be so designed as to distribute and spread aggregate across the selected width without segregation. Aggregate to be applied to the freshly sprayed surface by use of a comb screen for Class A and B Graded Aggregate Seals so that the largest particles are first placed on the road with the smaller fractions falling on top. The comb screen is to be mounted beneath the discharge openings of the spreader mechanism in such a manner that the angle of the comb screen relative to the road surface can be easily and quickly changed. Reverse flow aggregate spreaders are exempt from this clause.

Suitable provision to be made to prevent aggregate from rolling on the freshly sprayed surface. The cover aggregate should be applied ahead of the spreader wheels, with sharply defined, straight edges and without any lateral movement of the aggregate after initial application.

The spreader to be designed to apply aggregate at any application width between 2 m and 4.12 m. (Note: a 4.26 m hopper is required).

All joints should be at centreline or lane line.

508.21.03 Rollers - Self-propelled pneumatic tired rollers (minimum mass of 11,000 kg) to be used on the work.

All rollers shall be provided with equipment for spraying water continuously on all tires or wheels, while rolling is in progress, and also be provided with such means as may be required to keep the tires clean and free of adhering asphaltic binder.

508.21.04 Power Brooms - Brooming work to be carried out using rotary power brooms. The brooms to have sufficient width, power and brushing capacity to completely clean the surface of the standard lane to be treated or which has been treated within three coverages.

508.21.05 Water Truck - Water trucks to have a minimum capacity of 9000 ℓ. Water to be applied from a distributor of the pressure type, equipped with a spray bar mounting nozzles similar to those used on asphalt distributors and capable of applying the water accurately and uniformly.

Splash plate type of distributors or those equipped with spray bars that eject fine streams of water will not be permitted.

The distributor to be provided with a satisfactory means for accurately measuring the quantity of water sprayed. Measuring equipment is to be calibrated. The Contractor shall make all necessary arrangements for obtaining water.

508.21.06 Tanks, Mobile Asphalt Heating, & Storage – Insulated liquid asphalt storage tanks should meet the following minimum criteria:

- a) A heating system, capable to heat from 10° to 200°C.
- b) An automated heating and control system with safety shutdown.

GRADED AGGREGATE SEAL COAT (EPS)

PART D – CONSTRUCTION

508.31 Daylight Hours Only – Construction shall be carried out during daylight hours only.

508.32 Traffic Control and Signing – The Contractor shall submit, for the approval of the Ministry Representative, a Traffic Control Plan at least seven days prior to the pre-construction meeting.

Traffic Control on Seal Coat projects shall be in accordance SS 194 as well as the Ministry's publication "Traffic Control for Work on Roadways".

The Traffic Control shall be maintained at all times when in the opinion of the Ministry Representative, the risk of damage to the mat is likely to become a safety issue or to result in unnecessary vehicular damage from loosened rock. Additional traffic control to protect the quality of the product is also the responsibility of the Contractor.

Traffic through the work zone shall be limited to 50 km per hour, or as directed by the District Manager Transportation, until completion of final sweeping.

Extending traffic control beyond the end of the shift, in order to maintain safety and reduce vehicular damage risks, will not preclude the Contractor from providing and applying blinding material to further reduce these risks.

The Contractor shall, after discontinuing the application of product for the day, continue to maintain flag-person assisted traffic control over the extent of the day's production, for a minimum of 24 hours for work on numbered routes, 2 hours on other routes, or as specified in the Special Provisions.

508.33 Temperature and Weather – Air temperature shall be a minimum of 6°C for application of graded aggregate seals, and application shall cease when the temperature falls below that level.

No application shall take place when the weather is misty or rainy.

508.34 Grade Preparation – Immediately prior to the application of the graded aggregate seal coat on a previously constructed granular surface, the surface shall be watered, graded and compacted and/or broomed to provide a non-segregated, tightly knit surface free from loose rock. Cross-fall will be at 3% or as directed by the Ministry Representative and super-elevations developed uniformly and carried consistently through each curve.

508.35 Joints – All joints between adjacent passes of seal shall be at centreline or lane lines.

508.36 Communications – The flagpeople, pilot car or cars, sign truck, spreader and supervisor's vehicle shall have an effective electronic means of communication so that instructions and information can be quickly and accurately relayed over the total length of the control area.

508.37 Sweeping – Sweeping shall meet the requirements

SECTION 508

of SS 145, and SS 165 and the following:

a) Immediately prior to the commencement of the sealing operations, all loose aggregates, dust, dirt, caked clay or foreign materials shall be removed from the width of the surface to be treated by brushing with power brooms supplemented by hand push brooms, shovels or the use of a power grader, and where necessary by flushing.

b) Particular care shall be taken to thoroughly clean to outside edges of the strips to be treated and to ensure that the sweepings are not so deposited on the shoulder as to permit subsequent contamination of the treated surface.

508.38 Repair – Any patching or repair work required, in the opinion of the Ministry Representative, before sealing operations begin, may be done by the Contractor as directed by the Ministry Representative and paid for under as Extra Work.

508.39 Double Seal, Second Pass – Where the design calls for a double seal, the second pass of the surface treatment shall commence not less than 24 hours after completion of the first pass, subject to acceptable weather conditions as detailed in SS 508.33, and as the Ministry Representative may direct.

PART E - QUALITY CONTROL AND QUALITY ASSURANCE

508.41 Quality Control by the Contractor – The contractor shall be responsible for providing all resources required to carry out the quality control on all the constituent materials, processes and products, their testing and inspection, within the construction of the seal coat and the quality of the end product. (See SS 508 Appendix E - Quality Control Requirements and Guidelines).

508.41.01 Quality Control Plan – The Contractor shall prepare and submit a Quality Control Plan, in accordance with the Contract requirements, at least 7 days prior to the pre-construction meeting.

508.41.02 Sampling, Testing and Observing – The contractor shall provide properly maintained equipment, qualified personnel and shall maintain access to a qualified laboratory so that quality control tests and observations are performed and the results must be reported to the Ministry Representative within 48 hours. For asphalt emulsions, the test results must be received within 21 days of sampling.

The Contractor's Quality Control Plan shall provide details of the equipment provided, its calibration, and application methodology to meet the Contract requirements.

508.42 Quality and Quantity Control Records

508.42.01 Emulsion Quality – The Contractor is referred to tests performed on asphalt emulsion (SS 508 Appendix A). Quality control tests results for each batch of emulsion supplied to the job site must be made available to

GRADED AGGREGATE SEAL COAT (EPS)

the Ministry.

508.42.02 Aggregate Quality–

The Contractor shall assess the supplied aggregate to determine and satisfy themselves as to its suitability regarding quantity and quality for the intended application. Any modifications deemed necessary to ensure a quality product shall be made at the Contractor's expense.

508.42.03 Emulsion Usage – Daily emulsion usage shall be made available to the Ministry Representative on the Form "Emulsion Usage" (SS 508 Appendix C). Information shall be made available to the Ministry Representative within 48 hours and prior to demobilization of the storage tanks and pressure distributor from the Site.

Emulsion usage will be reconciled against initial tank volume, delivery records and remaining volume prior to the Contractor demobilizing from the Site.

508.42.04 Aggregate Usage – The Contractor shall monitor the aggregate spread rate on a production day basis and make the results available, in an acceptable format, to the Ministry Representative within 48 hours.

508.42.05 Daily Activity Log – The Contractor's Superintendent or designate shall complete and make available to the Ministry Representative the "Daily Activity Log" (SS 508 Appendix D) within 48 hours. This form shall be completed and submitted for all calendar days from the first day of mobilization to the last day of demobilization, for any day on which work was performed on Site.

508.42.06 Emulsion Sampling

i) The Contractor shall, procure and store a four litre sample of the emulsion from each tanker for use by the Ministry and/or Contractor.

These samples shall be obtained, handled and stored in accordance with ASTM procedure D 140 "Standard Practice for Sampling Bituminous Materials" and also with the manufacturer's recommendations.

ii) The samples shall be identified and retained by the Contractor until demobilization at which time permission may be granted by the Ministry Representative to discard the samples in an environmentally friendly manner.

iii) The Ministry Representative may provide the Contractor with a copy of the test results from the Ministry's Quality Management program. The Contractor shall not utilize these tests in place of their own Quality Control Program.

iv) The absence of Ministry test results shall not relieve the Contractor's obligation to remedy any defect in materials or construction.

508.42.07 Final Quantity Report – The Contractor shall supply to the Ministry Representative, prior to final acceptance of the work, the total amount of emulsion and

SECTION 508

graded aggregate seal aggregate used on the project, and the volume of unused emulsion remaining in the tank(s).

PART F - END PRODUCT ASSESSMENT

508.51 General - The Contractor shall provide an end product conforming in accuracy and detail as specified by the contract. Payment is based on end product assessment by the Ministry Representative.

508.52 Surface Deficiency Definitions – See SS 508 Appendix F “Surface Defects And Photographs” for examples and details of the conditions listed below.

508.52.01 Blackening – Blackening is the emergence of excess asphalt onto the finished surface whereby the finished surface becomes discoloured but the coarse surface texture remains. Under this condition, the effective cover stone can still be seen to protrude above the level of the asphalt binder’s upward migration

508.52.03 Flushing and Bleeding – Flushing and bleeding is the emergence of excess asphalt and fines onto the finished surface and the significant loss of coarse surface texture, leaving little or no effective cover aggregate visible.

508.52.04 Pock Marks – Pock Marks are indentations in the mat texture, normally less than the thickness of the graded seal layer, evidenced by the absence of effective cover aggregate in a small area. (No photograph available)

508.52.05 Pot Holes – Pot Holes are the loss of all cover aggregate and base material(s) into the underlying asphalt or gravel base. Pot Holes may develop because of seal and/or base weakness.

508.52.06 Ravelling – Ravelling is a general term for loss of cover aggregate, which can include numerous pock marks.

508.52.07 Streaking – Streaking is a continuous visible absence of effective cover aggregate often seen paralleling a ‘ridge’ of excess cover aggregate, characterized by the narrowness of its width and the significant extent of its length. Where streaking displays an absence of effective cover aggregate, the condition is unlike ravelling in that there was originally little or no effective aggregate in the area.

508.52.08 Washboard – Washboard is a condition of non-uniform surface texture caused by the buildup of transverse ridges within the graded seal layer itself, and characterized by a very rough, vibratory or chattering ride. (No photograph available)

508.53 End Product Evaluation

508.53.01 Lot Definition – A Lot shall be one lane kilometre of highway sealed. Sections of any road/highway remaining which are less than one-half (0.5) kilometres in length, will be included in the previous Lot. Sections remaining which are 0.5 kilometres or greater,

GRADED AGGREGATE SEAL COAT (EPS)

but less than one kilometre will receive a Lot designation unique for the road/highway.

508.53.02 Rating Time Criteria – The Ministry Representative will rate each Lot, within thirty (30) days of final brooming.

508.53.03 Performance Rating Criteria – Performance rating will be in accordance with the two tables in SS 508 Appendix F: *The Surface Defect Parameters Table* and the *Surface Defects Frequency Definitions*, and the photographs.

508.54 Deficiency Repair and Replacement – Any Lot of sealed surface which is found unacceptable shall be remedied in accordance with the (SS 508 Appendix F) “Surface Treatment Repair/Replacement Criteria”, until the whole project has been repaired or replaced as necessary and accepted by the Ministry Representative.

On double seal applications both the lower and upper lifts must be free of deficiencies prior to being accepted.

The sealing Contractor will not be responsible for deficiencies attributed to base, base failures and base work done by others. These may be repaired under a Provisional Sum Item provided for that purpose, or as ordered by the Ministry Representative.

For any defects being repaired through re-seal, the repair must cover the entire width of the highway (or to a centerline barrier), unless the Contractor can demonstrate that a compliant repair can be achieved at a narrower width without any longitudinal ridging which may adversely affect driver control or trap water adjacent to the edge of the repair.

508.55 Attention to Potential Safety Hazards – If, in the opinion of the Ministry Representative, remedial Work is required to correct a potential safety hazard it shall be undertaken immediately.

PART G - MEASUREMENT AND PAYMENT

508.61 Surface Seals – Surface Seal will be measured and paid by the square metre.

Payment in a double pass application will be for final top lift surface area only.

Payment will be full compensation for pre-cleaning the surface; loading, hauling, placing the asphalt emulsion and aggregate; compaction; brooming the finished surface; quality control and traffic control.

No extra payment will be made for any additional equipment, tools, labour or material used to replace, repair or overlay Unacceptable Work.

No extra payment will be made for any additional equipment, tools or labour employed to satisfy special brooming requirements.

508.62 Asphalt Emulsion – Asphalt emulsion will be measured and paid in litres of emulsion actually sprayed

SECTION 508

on the road, including supply, storage, heating and handling.

508.63 Aggregates - Aggregates will be measured by the cubic metre in stockpile. The volume will be determined by surveying and surface-to-surface volume calculations. Measurement shall be performed by the Contractor at the Contractor's expense using an independent surveying company. Survey results must be verified and signed off by the independent surveying company and survey results must be supplied to the Ministry.

Payment for aggregates will be at the Contract Unit Price per cubic metre in stockpile. Payment for aggregate will be only up to 100% of the Approximate Quantity as stated in Schedule 7.

No payment will be made for the supplying, hauling and placing of blinding sand.

GRADED AGGREGATE SEAL COAT (EPS)

The supply of extra aggregate, required to repair or overlay Unacceptable Work, will be the Contractor's responsibility. Where sufficient aggregate quantities are remaining in stockpile, the Ministry will make these available at no cost to the Contractor.

508.64 Stockpile Bases - The stockpile base must be prepared prior to surveying and stockpiling. No payment will be made for stockpile base preparation work and no payment will be made for materials required for the preparation of stockpile bases.

508.65 Claims for Vehicular Damage - Without in any way limiting the Contractor's obligations or liabilities herein, during construction and up until final acceptance of the whole project by the Ministry Representative, the Contractor shall be fully responsible for all claims for damages caused by the work and shall address and deal with each claim submitted.

APPENDIX A

Quality Control Tests, to be obtained by the Contractor from the Supplier, for High Float Emulsified Asphalts

<u>Test ASTM VERSIONS</u>	
ASTM D 140	Standard Practice for Sampling Bituminous Materials
ASTM D88	Saybolt Furol Viscosity
ASTM D-113	Ductility Test for Polymer Modified Emulsions
ASTM D-244 (CAN2-16.5-M84)	Residue by Distillation
ASTM D-5 (CAN2-16.5-M84)	Penetration of Asphalt Materials
ASTM D 4957 (CAN2-16.5-M84)	Absolute Viscosity of Asphalts
ASTM D-139 (CAN2-16.5-M84)	Method of Float Tests for Bituminous Materials

APPENDIX B

HIGH FLOAT EMULSIFIED ASPHALT REPORT (H-539)

Project No: _____

Refinery: _____

Contract: _____

Asphalt Grade: _____

Location: _____

Batch No: _____

Sampling Date: _____

Testing Date: _____

REQUIREMENTS	RESULTS	SPECIFICATIONS	
		MAXIMUM	MINIMUM
Residue by Distillation % by mass			
Oil Distillation % by volume			
Saybolt Furol Viscosity (SFS) 50°C			
Penetration 5 s/100 g/25° C			
Viscosity, mK or CM (Pa•s) 60° C			
Ductility, at 4°C			
Float Test (s) 60° C			

APPENDIX D

DAILY ACTIVITY LOG

1. **General**

Contractor _____ Address _____

Superintendent _____ Phone _____ Fax _____

Project No. _____ Hwy/Road _____

Project Description _____

Emulsion Manufacturer _____ Emulsion Type _____

Aggregate Source(s) _____ Aggregate Class _____

2. **Equipment** (e.g.: type, make and model of chip spreader)

3. **Weather**

at start-up

at shut-down

Ambient Temperature: _____

Road Surface Temp.: _____

General Conditions: _____

4. **Traffic Control**

Number/Type

Duration (From/to)

Pilot Vehicles _____

T.C.P.'s _____

Signs (specify) _____

5. **General Remarks** (e.g.: weather, dust, traffic volumes, mechanical, materials)

(Contractor's Representative)

(Date)

APPENDIX E

QUALITY CONTROL REQUIREMENTS AND GUIDELINES

1.01 GENERAL

The Contractor's guidelines for preparing, submitting and adhering to a Quality Control Plan are specified in SS 101, SS 508 Part E, the Special Provisions and this Appendix.

The QC Manager shall have at a minimum 5 years related experience in Quality Management.

1.02 QUALITY CONTROL PLAN

The Plan shall address all elements that affect the quality of the materials, end product seal coat, including but not limited to the following:

- Supply of Asphalt Materials
- Identification of source and proof of quality of aggregates to be supplied
- Aggregates production and its gradation control
- Quality of aggregate components during production
- Stockpile management
- Sealcoat Design(s)
- Distributor and spreader calibration
- Process temperature controls
- Material application rates
- Joints and tapers

1.03 CONTRACTOR'S RECORD OF QUALITY CONTROL TESTING

Test results should be made on specified forms or charts immediately after completion of each test. These test results are to be made available to the Ministry Representative upon request.

Records of gradation control during aggregate production should be kept on the form H-295 – Mechanical Analysis of Aggregates, or on a similar gradation analysis form acceptable to the Ministry Representative.

1.04 MATERIAL APPLICATION RATE

The Contractor shall control the Material Application Rate by monitoring the amount of emulsion and aggregate delivered to the road against the area covered by checking the application rates of the distributors and spreader.

1.05 OTHER QUALITY CONTROL PROCEDURES

The Contractor may initiate other Quality Control procedures as necessary for ensuring production of a quality product and include them in a Quality Control Plan. Procedures may also be introduced after the start of work as amendments to the Quality Control Plan.

1.06 QUALITY CONTROL TESTING FREQUENCY

Recommended test frequency requirements for Quality Control are described in Table 1 following:

TABLE 1 – TEST FREQUENCY GUIDELINES

	ASTM Test Designation	*Minimum Frequency
Tests Before Aggregate Production	D-75 Sampling Stone, slag, gravel, sand and stone block for use as Highway Materials	When Required
	C-117 Test for Materials Finer than 75 µm (No.200) Sieve in Mineral Aggregates by Washing	1 test (Representative Sample)
	C -142 Test Method for Clay Lumps and Friable Particles in Aggregates	1 test (Representative Sample)
	D 6928 Micro Deval	1 test (Representative Sample)
	D-5821 Fracture Count on Coarse Aggregate	1 test (Representative Sample)
	D-4791 Test Method for Flat Particles, or Flat and Elongated Particles in Coarse Aggregate	1 test (Representative Sample)
Tests During Aggregate Production	C-136, Standard Test Method for Sieve Analysis of Fine and Coarse Aggregates	- Main Stockpile -1 per each 1.5 hours production.
	D-5821, Determining the Percentage of Fractured Particles in Course Aggregate	- Main Stockpile -1 per each 1.5 hours production.
	C-117 – Test for Materials Finer than 75 µm (No 200) Sieve in Mineral Aggregates by Washing	- 1/shift on reduced sample obtained from combined samples from the crusher.
Tests on Emulsified Asphalt Products	D-244, Residue by Distillation	- minimum 1 per batch
	D-244, Saybolt Furol Viscosity	- minimum 1 per batch
	D-5, Penetration of Bituminous Materials	- minimum 1 per batch
	D-139, Float Test	- minimum 1 per batch
	D-4957, Apparent Viscosity on Residue	- minimum 1 per batch
	D-113, Ductility	- minimum 1 per batch on polymer modified emulsions.
Tests on Application of Sealcoat Materials	Emulsion Pan Test	- 3 per distributor/day. Test procedure, variation limits and actions should be outlined in Contractor's Quality Control Plan.
	Aggregate Pan Test	- 2 per spreader/day. Test procedure, variation limits and actions should be outlined in Contractor's Quality Control Plan.

* These are the recommended minimum frequencies and the contractor is responsible to assess the need to increase testing when required.

APPENDIX F

SURFACE DEFECT AND TREATMENT REPAIR/REPLACEMENT CRITERIA

SURFACE DEFECTS	SEVERITY	RATING PARAMETERS	REPAIR/REPLACEMENT METHOD
Loss of cover aggregate (Ravelling)	Very good	No noticeable aggregate loss	None
	Good	A few pock marks, less than 5 per 0.1 m ²	None
	Fair	Frequent pock marks closely spaced, more than 5 per 0.1 m ²	Reseal of affected area***
	Poor	Extensive pock marks or few surface disintegrations	Reseal of affected area***
	Very poor	Disintegration with potholes	Reseal of affected area***
Potholes	Very good	Few minor potholes, only involves graded aggregate seal	All potholes to be filled with asphaltic patching material at contractor's expense
	Good	Few deep potholes, involves granular base	All potholes to be filled with asphaltic patching material.(see SS 508.54)
	Fair	Intermittent potholes	Patch potholes and reseal affected area*** (see SS 508.54)
	Poor	Frequent potholes	Patch potholes and reseal affected area*** (see SS 508.54)
	Very poor	Extensive or potholes throughout	Patch potholes and reseal affected area*** (see SS 508.54)
Flushing / bleeding	Very good	No/very faint colour change in wheel path	None
	Good	Few sections with asphalt on surface	None
	Fair	Intermittent sections with asphalt on surface	Application of sand blotter
	Poor	Frequent sections with asphalt on surface, has wet look or asphalt on surface throughout	Reseal of affected area. Removal of initial surface treatment at Contractor's option***
	Very poor	Wet look with noise like a wet pavement	Reseal of affected area. Removal of initial surface treatment at Contractor's option***
Total failure	Any	Any condition where the asphalt material softens or disintegrates under traffic and aggregate is picked up or "kicked off" by traffic	Remove and dispose of failed surface treatment in its entirety and apply new surface treatment
Streaking (see raveling)	Any	Absence of cover aggregate caused by too little binder - characterized by long, narrow sections of little or no stone cover	Reseal of affected area
Washboard	Any	Any condition of repetitive build-up across the travel lane	Remove and reseal affected area

*NOTE:*** Reseal for these defects shall consist of a new graded aggregate surface treatment, single pass application. Area of the reseal repair/replacement shall not be less than one lane width, 10 metres in length. If there is less than 10 metres between two sections in the application pass designated for repair/replacement, the repair/replacement shall be continuous.*

APPENDIX F (Continued)

SURFACE DEFECTS FREQUENCY DEFINITIONS

DENSITY OF SURFACE DEFECTS**			
SEVERITY	RAVELLING (% LENGTH)	POTHoles (NUMBER)	FLUSHING/BLEEDING (% LENGTH)
Very Good	<5%	0 - 1	<5%
Good	5% - 20%	2 - 15	5% - 20%
Fair	21% - 50%	16 - 30	21% - 50%
Poor	51% - 80%	31 - 50	51% - 80%
Very Poor	>80%	>50	>80%

Note: ** Based on number of surface defects or percent of surface affected by defect, per Lot as defined in SS 508.53.01.



Blackening





Flushing or Bleeding





Raveling or Stripping



SECTION 511

COLD MILLING

DESCRIPTION

511.01 Scope - This work consists of preparing a foundation for placement of new surfacing by cold milling the existing pavement surface.

EQUIPMENT

511.21 Milling Machine - The milling machine shall be self-propelled and shall be equipped with automatic longitudinal and transverse grade control, which shall be used when directed by the Ministry Representative. A profiling ski or boom of a minimum 4 m length, approved by the Ministry Representative, shall be used. No substitute equipment will be permitted. The cutting drum shall be a minimum of 1.8 m in width, totally enclosed and with replaceable cutting teeth. There shall be an effective means of removing the loosened material from the surface and for preventing dust from escaping into the air.

511.22 "Kill" Switch - All pavement milling machines shall be equipped with a "kill" switch installed or approved by the manufacturer of the milling machine. This "kill" switch shall be automatically actuated whenever the operation of the machine is so impeded that a hazardous situation, such as "kick back", would result were that operation to continue. When so actuated the "kill" switch shall instantly shut down the operation of the milling machine.

511.23 Audible Back Up Warning Device - See Subsection 145.30.04.

CONSTRUCTION

511.31 Traffic Control Person - A haul vehicle traffic control person shall be provided during cold milling operations. This individual's sole duty shall be to signal and direct hauling vehicles to exit, back into and pull away from the milling machine, and to re-enter the traffic stream in a safe manner in accordance with existing requirements.

511.32 Pavement Removal - The existing pavement shall be removed to the depth and width as specified in the Special Provisions, on the drawings or as directed by the Ministry Representative to provide a surface that is free of longitudinal and transverse irregularities. The use of a heating device to soften the pavement will not be permitted.

At all times, during the milling operation, the traveled roadway shall be kept clean of all loose materials.

At the end of the milling shift or at the end of each section to be milled, prior to reopening the road to traffic, the pavement shall be cleaned and swept so that all loose material is removed. Also, the transition from the milled surface to the existing paved surface shall be tapered at a maximum slope of 25:1, or as directed by the Ministry Representative. The Ministry Representative shall indicate

whether the taper is to be milled or a tar paper letdown shall be constructed using asphalt mix.

On extensive milling projects no more than one milling shift shall be carried out in any one lane so as to minimize the length of the grade difference between the lanes. At no time, at the end of a shift, shall there be a grade difference that is not at lane dividing lines, centre line or at locations indicated by the Ministry Representative. When the milling operation traverses intersecting roads or on and off ramps, the transition from the milled surface to the existing pavement shall be at a maximum slope of 25:1 or as directed by the Ministry Representative. This transition can be done with the milling machine or by using tar paper letdowns as approved by the Ministry Representative.

If, due to delays between the milling and paving operations, the milled surface starts to pothole or deteriorate, repairs shall be carried out at once using asphalt mix. At no time shall there be a grade difference between lanes of more than 50 mm at the end of a shift. If the milling is carried out to a depth greater than 50 mm, the full width of the driving surface shall be milled or a lift of leveling course shall be constructed to maintain a maximum depth of 50 mm.

At those locations where milling is conducted the Contractor shall cut drainage channels as required to prevent water from collecting in the milled area.

If washouts occur at any time during the milling operations, they shall be immediately repaired by the Contractor, at the Contractor's own expense, with approved materials and as directed by the Ministry Representative.

511.33 Disposal of Materials - The disposal of materials removed under this section which are not recycled and used on the project shall become the property of the Contractor at the point of removal, unless otherwise specified. Materials shall be disposed of outside the limits of the project in a manner satisfactory to the Ministry Representative and shall meet all environmental requirements. The procurement of a disposal site, if required, shall be the Contractor's responsibility.

MEASUREMENT

511.81 General - Cold Milling will be measured by the SQUARE METRE or the TONNE. The area quantities will be determined by measurement of the actual surface area from which the materials have been removed and computed to the nearest square metre. Measurement of material by mass shall be done in accordance with Subsections 145.18.04 and 145.19 before moving to stockpile.

SECTION 511

COLD MILLING

PAYMENT

511.91 General - Payment for COLD MILLING will be at the unit price bid per square metre or tonne as specified in the Special Provisions. The unit price shall be for all things furnished and done including servicing all equipment, replacing teeth on the cutting drum, performing all work to remove the existing pavement by milling, and the provision for a traffic control person as set out in Subsection 511.31. No additional payment will be made to load, haul and place the material in stockpile.

511.92 Asphalt Mix - Asphalt mix required to repair the milled surface as set out in Subsection 511.32 shall be paid for as set out in the Special Provisions.

511.93 Contractor - The Contractor will be advised of the existence of manholes, catch basins, valves, boxes and other utilities on the project. Care must be taken not to disturb or damage any such structures or devices. Damage to visible, referenced, or plan-indicated manholes, catch basins, valves, valve covers and concrete/asphalt curb, or any other infrastructure shall be repaired at the Contractor's expense. All metal and concrete faces must be cleaned of old pavement and painted with primer, at the Contractor's expense, prior to repaving.

SECTION 514

HOT IN-PLACE RECYCLE

DESCRIPTION

514.01 Scope - This Specification describes the equipment, work practice and materials required for carrying out Hot In-Place Recycle operations.

MATERIALS

514.11 Rejuvenating Agent-Requirements - The Contractor shall supply only a Ministry of Transportation approved rejuvenating agent meeting the requirements as shown in Table 514-A.

514.12 Asphalt Mix - When the Special Provisions require the addition of virgin mix to be incorporated into the recycled asphalt mix, it shall meet the requirements as shown in the Special Provisions. The Ministry Representative shall be advised five working days in advance of commencement of work of the source of Virgin Mix for testing purposes.

When the Contractor is required to supply asphalt mix for repair work, the Ministry Representative is to be advised of the mix source so that it may be tested and approved prior to being required.

EQUIPMENT

514.21 General - All equipment and instrumentation shall be capable of performing the work in accordance with these specifications.

514.22 Processing Equipment - The equipment shall have the capability to process the existing pavement to a minimum depth of 50 mm yielding an average mass of 120 kg/m² of existing pavement being processed.

The equipment shall be capable of heating the existing pavement to a width 100 to 200 mm wider than the width to be processed and to a temperature, behind the screed, of not less than 110°C. The equipment shall be regulated so that excessive heating and burning of the existing asphalt cement does not occur. This will generally require the existing surface to be radiantly heated and no open flame will be permitted.

The scarifying tines or cutting drum(s) shall mill to the specified cross-section and shall be set so as to produce a fully homogenous recycled mixture free of lumps.

The equipment shall have an activated heated screed complete with augers and strike-off device, in accordance with Section 501, capable of distributing and placing the reprocessed mix to the full width of the pavement being recycled.

The equipment shall have a minimum production rate of 500 m² per hour except between June 1st and September 8th when the minimum rate shall be 700 m² per hour.

Rejuvenating agents that contain water will not be permitted.

TABLE 514-A SPECIFICATIONS

ASTM Test	TITLE OF TEST	SPECIFICATION
D 2726	Bulk Relative Density of Compacted Bituminous Mixtures using Saturated Surface Dry Method	
D 1188	Bulk Relative Density of Compacted Mixes Using Paraffin Coated Method	
D 1559	Resistance to Plastic Flow of Bituminous Mixtures Using Marshall Apparatus	
D 2170	Kinematic Viscosity @ 60°C	200-500 mm ² /sec
D 70	Specific Gravity	0.98-1.02
D 92	Flash Point by Cleveland Open Cup	204°C Min.
D 1160 (10 mm Hg)	Volatility - IPB - 2% v. - 6% v.	150°C min. 190°C min. 210°C min.
D 2007	Saturates, % w	28 max.
D 2006-70	Asphaltenes, % w	1.5 max.
D 2006-70	Chemical Composition (PC+A ₁)/(S+A ₂)	0.4-0.8

The hot recycling unit shall be equipped and capable to add and homogeneously blend any specified proportion of virgin Asphalt Mix into the reclaimed material and shall be equipped with a means to introduce a rejuvenating agent homogeneously into the reclaimed mixture.

The Contractor's compaction equipment shall conform to SS 502.15 in its entirety.

Individual pre-heating and reprocessing units shall be equipped in such a way that the operator and other workers are not exposed to any hazardous fumes or gases produced from the equipment operation, the heated pavement or from the addition of the rejuvenating agent, in accordance with all applicable regulations.

514.23 Rejuvenating Agent Equipment - To accurately proportion the rejuvenating agent into the scarified mixture the equipment shall comply with the following requirements:

- a) positive feed and shut off of the rejuvenating agent, governed by the movement of the reprocessing machine
- b) control of the quantity of rejuvenating agent to $\pm 0.05 \ell/m^2$ of surface reprocessed with an agent application range of $0.0 \ell/m^2$ to $1.0 \ell/m^2$
- c) measurement of the rejuvenating agent applied by means of a metering device, which is capable of recording accumulated litres to the accuracy of $\pm 2\%$, and which is fully visible to both the operator and the Ministry Representative
- d) mechanically or electronically controlled application of the rejuvenating agent relative to and variable with the processing rate of the equipment
- e) a mechanical or electronic metering device capable of supplying an accurate indication of the quantity of rejuvenating agent being applied per square metre
- f) a mechanical, electronic or manual method of measuring the quantity of rejuvenating agent in the tank
- g) heating of the agent to within $\pm 5^\circ C$ of the application temperature established by the manufacturer and/or the Ministry Representative.

CONSTRUCTION

514.31 Preliminary - If required, prior to starting work, as directed by the Ministry Representative, the existing paved surface shall be cleaned to avoid contamination of the recycled pavement. It shall be swept back at least 20 cm wider than the area to be processed.

Prior to proceeding with the road work, the Contractor shall ensure that all catch basins and manholes, which are within the operating area of the heating units, are clear of any flammable liquids or otherwise hazardous fumes/gases. The local Fire Authority may be of assistance in this regard.

514.32 Recycling - The existing highway pavement shall

be heated, planed, reprocessed, with or without the addition of a rejuvenating agent or virgin mix as specified, remixed, replaced and compacted using a heater scarification or hot milling process and rollers.

The recycled material shall not be heated over an average of $150^\circ C$ in order to avoid excessive oxidation and hardening of the recycled Asphalt Cement.

At locations where reprocessing operations begin and end, the Contractor shall ensure that the transition between the processed and unprocessed surface is smooth and without irregularities. If any irregularities occur resulting from the reprocessing operation, the Contractor shall repair these areas with fresh asphalt mix and/or additional reprocessing, at the Contractor's own expense, as directed by the Ministry Representative.

At all times the Contractor shall ensure that the appropriate cross slopes for safety and positive pavement drainage are maintained.

The Contractor shall ensure that the longitudinal edges of the recycled pavement are blended to conform in elevation with the adjacent pavement unless this surface is scheduled to be recycled.

Generally, the outer edge of each lane will be tapered to a 12:1 slope.

Excess materials shall be removed and deposited in a location such that they can be reincorporated into the recycled mixture. At no time shall excess material be cast across the newly processed surface or incorporated into the granular shoulders.

514.33 Compaction and Finishing - Immediately behind the reprocessing operation, the Contractor shall supply roller compaction to obtain a minimum of 97% laboratory density. The laboratory density will be the specimen density (Test ASTM D2726 or D 1188) that results from heating a representative sample of the existing pavement, or rejuvenated and blended mixture, as applicable, to a temperature of $130^\circ C$ and producing a compacted laboratory specimen using the procedure for 75 blow Marshall method. (Sample preparation shall be in accordance with applicable portions of Test D 1559).

The mix for compaction testing shall be obtained behind the screed of the laydown machine, and the roadway shall be marked at that location for subsequent drilling of the core. The core shall be cut at the specified heater recycling thickness prior to obtaining its density.

The reprocessed mat shall have a uniform appearance. Any deficiencies shall be corrected, at the Contractor's expense, to the satisfaction of the Ministry Representative.

The completed Hot In-Place Recycled surface shall conform to all requirements of SS 501.10.

MEASUREMENT

514.81 General - Hot In-Place Recycle will be measured

SECTION 514

by the SQUARE METRE of finished product. The area will be determined by measurement of the reprocessed mat and computed to the nearest square metre.

514.82 Rejuvenating Agent - Rejuvenating agent will be measured by the LITRE.

514.83 Additional Virgin Mix - Additional Virgin Mix will be measured by the TONNE.

PAYMENT

514.91 General - Payment for HOT IN-PLACE RECYCLE of asphalt pavement will be at the Contract Unit Price per square metre. The Contract Unit Price shall be for all things furnished and done including sweeping,

HOT IN-PLACE RECYCLE

processing, compacting, and patching as necessary to complete the work. There shall be no additional payment for areas of "overlap" such as at tapers and joints.

514.92 Rejuvenating Agent - Payment for REJUVENATING AGENT will be at the Contract Unit Price per litre. The Contract Unit Price shall be to supply, store, heat, apply and blend with the asphalt pavement mixture reclaimed from the roadway.

514.93 Additional Virgin Mix - Payment for adding VIRGIN MIX at the recycling train will be at the Contract Unit Price per tonne. The Contract Unit Price shall be for all things furnished and done to produce the mix, haul and add the mix to the recycling operation.

THIS PAGE IS LEFT INTENTIONALLY BLANK

SECTION 515

HOT-IN-PLACE RECYCLED ASPHALT PAVEMENT (EPS)

PART A - GENERAL

515.01 General – This Section describes the materials, equipment, professional standards and end product requirements for the construction of Hot In Place Recycled Asphalt Pavement.

End Product Specifications contain the acceptance and payment criteria based on the results of specified sampling and testing. Payment of the contract Unit Prices for the hot in place asphalt pavement product is subject to adjustments upward and downward in accordance to the provisions provided in End Product Specifications (EPS).

515.02 General Description Of Work - The Contractor will be responsible for the following work associated with the construction of hot in place asphalt pavement by EPS:

- Preparing a Quality Control Plan for evaluation before commencing the Work and providing at the production site a testing facility to provide the data needed to implement that plan.
- Supplying, screening, crushing, processing and improving aggregate to produce virgin asphalt mix aggregate.
- Supplying and delivering asphalt cement meeting the requirements of SS 952.
- Supplying and delivering rejuvenating agents meeting the requirements of SS 514.11 and SS 514.23.
- Heating the virgin asphalt mix aggregate and mixing it with asphalt cement to produce asphalt admix that meets the Job Mix Formula.
- Hauling, and adding the asphalt admix into the recycling process.
- Recycling the existing highway pavement by heating, milling, reprocessing, with or without the addition of rejuvenating agents or admix (virgin mix) as specified, re-mixing, replacing and compacting using a multi-stage, hot milling process and rollers.

The Contractor shall provide an end product conforming in quality and accuracy of detail to the dimensional and tolerance requirements of the contract. Where no tolerances are specified, the standard of workmanship shall be in accordance with normally accepted good practice and those identified in SS 514. Payment is subject to adjustments based on quality assurance tests performed by the Ministry Representative.

The Ministry shall provide information pertaining to the gradation of the admix, asphalt content, addition rates for rejuvenating agents and the percentage of admix to be incorporated.

515.03 Definitions Relevant To End Product Specification

515.03.01 End Product Specification (EPS) - A specification whereby the Contractor is entirely responsible for quality control of the construction processes, and whereby the Ministry performs the specified quality assurance sampling and testing of the end product for the purpose of determining acceptance/rejection and payment.

515.03.02 Job Mix Formula - The Job Mix Formula, supplied by the Ministry, establishes the virgin aggregate proportions, gradation, the asphalt content and type of asphalt to be used for production of asphalt admix. The Job Mix Formula is based on an asphalt mix design, in accordance with SS 515.05.06, or on a variation in accordance with SS 515.05.07.

515.03.03 Asphalt Admix - The Asphalt Admix is virgin asphalt mix added to the recycled mix. The Asphalt Admix is project specific designed and is blended homogeneously within the recycling process. The Asphalt Admix becomes an integral component of the recycled pavement structure.

515.03.04 Asphalt Content - Asphalt Content means the quantity of asphalt cement in the virgin admix expressed as a percentage by weight of the total dry aggregate in the mix.

Design Asphalt Content - The asphalt content upon which the Job Mix Formula is initially established.

Approved Asphalt Content - The design asphalt content or subsequent adjustment to it, embodied in a Job Mix Formula or revised Job Mix Formula.

Actual Asphalt Content - Actual asphalt content is the amount of asphalt cement in the admix as determined by the Contractor's Quality Control Testing.

515.03.05 Smoothness - Smoothness is a measure of the longitudinal profile of the pavement surface. The unit for measurement is the International Roughness Index (IRI).

515.03.06 Sample Mean - The Sample Mean is the arithmetic mean of a set of test results constituting the sample.

515.03.07 Stratified Random Sample - A Stratified Random Sample is a set of test measurements taken one each from a number of separate (stratified) areas or Sub-Lots within a Lot in an unbiased way.

515.03.08 Lot - A Lot is a portion of the work being considered for acceptance and for the determination of payment. A Lot is defined as follows.

For the application of the contract requirements for:

- Density,

A Lot shall be one day's scheduled production of at least 7 hours of pavement recycling where no changes have occurred to criteria such as but not limited to:

- approved Job Mix Formula,
- the specific thickness to be processed,
- the required materials addition rate,
- change in the ratio of the components making up the Hot In Place Recycled Pavement.

A change in any above criteria may require a new Lot designation.

One day's production of less than 7 hours will be dealt with as follows:

- the material will be added to the next Lot that has the same criteria, as described above, except that
- if a test indicates that this production is subject to a payment adjustment or to rejection, or if no further material will be produced with the same criteria, this production will be designated as a separate Lot,

A Lot shall be no more than two days total production even if the above criteria have not changed or been met.

For application of the contract requirements for:

- Smoothness,

A Lot shall be one kilometre length of recycled pavement for each driving lane.

515.03.09 Sub-Lots for Density and Smoothness - For the application of the contract requirements for:

- Density, each Lot shall be divided into three equal Sub-Lots.
- Smoothness, each Lot shall be divided into 100 metre Sub-Lots.

515.03.10 Driving Lane - A driving lane shall mean a single lane in any area of the pavement other than a shoulder or a barrier flare.

515.03.11 Surplus Aggregate - Surplus aggregate is aggregate surplus to the works, in split or un-split stockpiles which singly or combined will meet the virgin asphalt mix aggregate gradation. Surplus aggregate will be paid for as indicated in SS 515.32.01. There will be no payment for reject aggregate.

515.03.12 Hot In Place Recycled Pavement - Hot In Place Recycled Pavement shall be the result of the process where recycling, the addition of admix and/or rejuvenating agents, the spreading, compacting and finishing of the asphalt pavement have taken place to form a quality finished product. The Hot In Place Recycled Pavement

may be comprised of the following components: existing asphalt pavement, admix, and/or rejuvenating agents.

515.04 Quality Control

515.04.01 General - Quality Control, by the Contractor, is the sum total of activities by the Contractor to ensure that a product meets contract specification requirements. Quality Control includes material handling and construction procedures, calibration and maintenance of equipment, production process control and any sampling, testing and inspection that is done for these purposes.

The Contractor is responsible for all Quality Control under this specification. The Ministry Representative will audit and monitor the Contractor's operations and the implementation of the Contractor's Quality Control Plan.

The Ministry will not take samples for quality control testing and will in no manner assist in any degree or in any aspect of the Contractor's operation in the production of asphalt pavement, beginning from the production of aggregate through the compaction of asphalt mix. The only exception shall be in accordance with the provisions of SS 515.05.07, where the Ministry shall have the ability to adjust the ratio of the components of the Hot In Place Recycled Pavement based upon the Contractor's Quality Control Results and visual inspections.

The Ministry Representative may issue a Stop Work Order to the Contractor if the Contractor fails to adhere to the Quality Control Plan. The Ministry Representative will not issue a Resume Work Order until the Contractor has given the Ministry Representative satisfactory assurance that it has in place adequate capacity to fulfil the requirements of the Quality Control Plan.

515.04.02 Quality Control Plan - The Contractor shall prepare a detailed, written Quality Control Plan, based on the guidelines as shown in Appendix 1 and functions integrally with any other Quality Management provisions of the Contract. The Contractor's Quality Control Plan shall be submitted to the Ministry Representative not less than five working days before starting the production of paving aggregate. The Ministry Representative will evaluate the Contractor's Quality Control plan and will respond, in writing, within five days. Any subsequent changes to the Contractor's Quality Control Plan must also be submitted to the Ministry Representative for evaluation.

The Contractor's Quality Control Plan shall include a description and schedule of the intended sampling, testing and reporting. The Quality Control Plan must also include a detailed description of the means by which the Contractor shall use the quality control test results to ensure that the asphalt materials, aggregate, mix production, recycling and pavement compaction processes will be controlled to keep the end product within the specified limits. The Quality Control Plan must clearly show the flow of information from the quality control laboratory to the individuals who shall make the actual

adjustments to the processes and equipment to this control. The plan will show time allowance for each step, the names and positions of all the people involved, and a clear description of the responsibilities of each.

515.04.03 Quality Control Testing and Inspection -

The Contractor shall provide and maintain equipment and qualified personnel to perform all laboratory testing, field testing and inspection necessary to determine and monitor the characteristics and properties of all the materials produced and incorporated into the work. They shall also monitor the workmanship of the final product in accordance with the Quality Control Plan as most recently submitted.

The Contractor shall use a qualified registered member of the Association of Professional Engineers and Geoscientists of British Columbia or a qualified, registered member of the Applied Science Technologists and Technicians of British Columbia. This person shall be designated as the Quality Control Manager for the purposes of these specifications. The Quality Control Manager shall be responsible for preparation and sign off of the Quality Control Plan, shall be responsible for all Quality Control testing and inspections and shall be responsible for the signing of all Quality Control testing and inspection records and submissions to the Ministry.

The Contractor shall provide a testing facility(s) that meets the requirements necessary to carry out all the test procedures listed within this Section. The facility(s) must have the equipment specified under the appropriate test designation to perform the tests.

All equipment and the laboratory shall be well maintained and in good working condition. All testing equipment shall be calibrated and evidence of the calibration shall be provided when requested by the Ministry Representative.

515.04.04 Quality Control Records - The results from quality control testing shall be reported on test logs and plotted on charts immediately after each test is completed. These test results, reports and charts shall be available, within 24 hours of the end of each shift, to the Ministry Representative and at all times during the progress of the work.

For the purposes of confirming delivery of asphalt mix to the road and the calculation of material application rates, the Contractor shall prepare and provide to the Ministry Representative, a copy of the Road Checker's Summary and the weigh tickets for each load received at the recycling operation at the end of each shift. The Road Checker's Summary shall include, but not be limited to, the following information:

- a) Truck Number
- b) Weigh Ticket Number and Net Weight of load
- c) Time and location by station of delivery

d) Admix and Rejuvenator Material Application Rate Calculations

e) Processed Depth, Lengths and Widths

f) Temperatures (behind screed, windrow, ambient and admix)

g) Notes pertaining to the paving of any appurtenances (intersections, tapers, etc.)

515.04.05 Final Quality Control Testing Reports -

Prior to the issuance of a Completion Certificate, the Contractor shall provide the Ministry Representative with:

- a summary of all virgin aggregate quality control test results;
- copies of all quality control test results for asphalt admix properties, Hot In Place Recycled Pavement and compaction; and
- copies of all quality control charts.

515.04.06 Minimum Acceptable Construction Practices -

Good construction practices shall be considered as standard construction procedures to be followed and shall include but not be limited to the procedures described below.

Stockpiles – Stockpiles of different types of material shall be located and constructed in such a manner as to prevent intermingling of the types and segregation of material.

Haul Vehicles – Lubrication of the truck boxes with diesel fuel will not be permitted. All vehicles shall have adequately insulated truck boxes and shall be equipped with an insulating tarpaulin of such size as to completely protect the asphalt mix.

Existing Paved Surfaces – Existing paved surfaces shall be clean to avoid contamination of the recycled pavement. The existing surfaces shall be swept back at least 20cm wider than the area to be processed.

Existing Utility Structures – The Contractor shall ensure all catch basins and manholes, which are within the operating area of the heating units are clear of any flammable liquids or otherwise hazardous fumes/gases.

Heating of Recycled Material – The recycled material shall not be heated over an average of 150°C in order to avoid excessive oxidation and hardening of the recycled Asphalt Cement.

Minimum Admix Temperature – Based on the most recent Temperature Viscosity Curve supplied by the Asphalt Cement Supplier. This information will be used to set minimum and maximum mixing temperatures.

Longitudinal Joints – Longitudinal joints in the top lift of asphalt pavement will generally only be permitted where lane dividing lines are to be painted.

TABLE 515-A-1 STANDARD SAMPLING AND TESTING PROCEDURES FOR VIRGIN AGGREGATES

All virgin aggregate tests shall use the following sieve sizes:

37.5 mm, 25 mm, 19 mm, 16 mm, 12.5 mm, 9.5 mm, 4.75 mm, 2.36 mm, 1.18 mm, 0.600 mm, 0.300 mm, 0.150 mm, and 0.075 mm.

Item	Procedure	ASTM Test Reference
1	Sieve Analysis of Fine And Coarse Aggregates	C 136
2	Materials Finer Than 0.075 mm (No. 200) Sieve in Mineral Aggregate by Washing	C 117
3	Specific Gravity and Absorption of Coarse Aggregate	C 127
4	Specific Gravity and Absorption of Fine Aggregate	C 128
5	Determining the Percentage of Fractured Particles in Coarse Aggregate	D 5821
6	Total Moisture Content of Aggregate by Drying	C 566

TABLE 515-A-2 STANDARD SAMPLING AND TESTING PROCEDURES FOR ASPHALT CEMENT

Item	Procedure	ASTM Test Reference.
1	Penetration of Bituminous Materials	D 5
2	Viscosity of Asphalt by Vacuum Capillary Viscometer	D 2171

Minimum Temperature – Minimum Temperature behind the paver screed of the recycled material shall not be less than 110°C.

Metering of Rejuvenating Agents – To accurately proportion the rejuvenating agent into the hot milled material, the equipment shall control the quantity of the rejuvenating agent to $\pm 0.05 \ell/m^2$ of surfaced reprocessed with an agent application range of $0.0 \ell/m^2$ to $1.0 \ell/m^2$. The measurement of the rejuvenating agent applied by means of a metering device shall be capable of recording accumulated litres to the accuracy of $\pm 2\%$, and be fully visible to both the operator and the Ministry Representative.

TABLE 515-A-3 STANDARD SAMPLING AND TESTING PROCEDURES FOR VIRGIN ASPHALT ADMIX AND HOT IN PLACE RECYCLED PAVEMENT

Item	Procedure	ASTM Test Reference
1	Bulk Specific Gravity and Density of Non-Absorptive Compacted Bituminous Mixtures	D 2726
2	Theoretical Maximum Specific Gravity and Density of Bituminous Paving Mixtures	D 2041
3	Sampling Compacted Bituminous Mixtures for Laboratory Testing	D 5361
4	Resistance to Plastic Flow of Bituminous Mixtures Using Marshall Apparatus	D 1559
5	Determining Asphalt Content by Ignition Methods for Admix.	D 6307

TABLE 515-A-4 TEST SAMPLE SOURCE LOCATIONS

Test	Sample Source:
Density	150mm diameter. road cores
Smoothness	Center of Lane

Outer Edges – The outer edge of each lane shall generally be tapered to a 12:1 slope.

Recycling Adjoining Mats – When recycling an adjoining parallel mat there shall be at least a 50-mm overlap onto the previously recycled surface. This overlap shall be properly “raked” to form a homogeneous bond between the two mats.

Raking – Any material that is raked from the joint shall not be placed on the new mat or placed on or in front of the paver. This material may be introduced at a point of the operation where the material shall be reheated and remixed with the Hot In Place Recycled Pavement.

Discontinued Paving - At locations where reprocessing operations begin and end, the Contractor shall ensure that the transition between the processed and unprocessed surface is smooth and without irregularities. If any irregularities occur resulting from the reprocessing operation, the Contractor shall repair these areas with fresh asphalt mix and/or additional reprocessing, at the Contractor’s own expense.

Pavement Drainage – The Contractor shall at all times ensure that the appropriate cross slopes for safety and positive pavement drainage are maintained.

Rollers – Rollers shall normally operate with the drive wheel nearest the paver and at a speed not in excess of 8 km/h. They shall not be allowed to park on the mat prior to complete cooling.

515.05 Supply Of Virgin Aggregates, Asphalt Materials, Asphalt Admix Design And Job Mix Formula

515.05.01 Work in Ministry Pits or Quarries - When operating in a Ministry pit or quarry, the Contractor shall comply with all provisions of SS 145.26.

515.05.02 Supply of Virgin Aggregates, Aggregate Production and Characteristics - The Contractor shall not produce paving aggregate until the Contractor has received written notification that the Quality Control Plan is in accordance with SS 515.04.02, and has in place testing facilities for aggregate production that are in accordance with the Quality Control Plan.

For the production of virgin Asphalt Mix Aggregate, within Ministry pits, the Contractor shall provide crushing equipment that will permit all aggregate, that passes through 375 mm x 450 mm slotted openings, to be used for the production of crushed aggregate. Rocks, which will not pass through these openings, shall be stockpiled or disposed of as directed by the Ministry Representative. Crushing and screening equipment shall be provided with adequate facilities and capacity to be able to bleed off reject aggregate and remove any excess fine aggregate, dust or objectionable aggregate coatings, to make it acceptable for use. All products from crushing or screening plants, that can be used shall not be wasted, and shall be stockpiled or used as directed by the Ministry Representative.

Where the Ministry has available any test result information on the properties shown in Table 515-B, for a Ministry pit or other source, the Ministry Representative will upon request, provide that information to the Contractor. Otherwise, sampling and testing to determine and demonstrate the compliance of paving aggregate with the requirements of this Section shall be the responsibility of the Contractor.

Paving aggregates shall meet the following requirements:

a) Virgin Coarse Aggregates;

- i)** shall be all mineral matter retained on the sieve designated in the test procedures for each individual test.
- ii)** shall consist of crushed stone, crushed gravel, or combination thereof, or materials naturally occurring in a fractured condition, or materials naturally occurring of highly angular nature or rough texture.

iii) shall be free from coating of clay, silt or other deleterious material, and shall meet the requirements listed in Table 515-B.

TABLE 515-B – REQUIREMENTS FOR VIRGIN COARSE AGGREGATES

ASTM Test Reference	Requirements	
C 127	Maximum Water Absorption: % by Mass	2
C 88	Soundness of Aggregate Maximum Loss After 5 Cycles	20
C 142	Maximum % by Mass of Clay Lumps and Friable Particles	1.5
D 6928	Minimum Degradation Factor	35
D 5821	2 Fractured Faces: Minimum % by Mass Retained on the 4.75 mm sieve	85

b) Virgin Fine Aggregate

i) shall be clean, tough, durable, moderately sharp, and free from coatings of clay, silt, or other deleterious material, and shall contain no clay balls or other aggregations of fine material.

ii) shall have a maximum mass loss after five cycles of not more than 23% when tested in accordance with ASTM Test C 88.

iii) shall have a sand equivalent of not less than 40 when tested in accordance with ASTM Test D 2419

iv) shall have a minimum value of 45 when tested according the AASHTO Test T 304, Method “A”, - Uncompacted Void Content of Fine Aggregate when determining Fine Aggregate Angularity.

c) Virgin Mineral Filler and Mineral Dust

i) Mineral filler shall consist of all matter passing the 0.600-mm sieve and mineral dust shall consist of all mineral matter passing the 0.075-mm sieve.

ii) Mineral filler and mineral dust shall be free from organic matter.

iii) Mineral filler shall be non-plastic when tested in accordance with ASTM Test D 4318.

515.05.03 Supply of Asphalt Cement and Rejuvenating Agents - The Contractor shall supply the types and grades of asphalt cement and rejuvenating agents as specified in the Special Provisions. The supply of these materials includes, but is not limited to, ordering, scheduling delivery of, supply of Temperature Viscosity Curve information, receiving, handling, storing, heating,

blending, sampling, and testing of the materials and other related work.

The Contractor shall supply the Ministry Representative with copies of the supplier’s weigh-bill and records of all asphalt and rejuvenating materials received on a daily basis. The amount of asphalt cement used will be calculated based on the Contractor’s Quality Control testing results.

The supply of asphalt cement and rejuvenating agents shall be at the Unit Price bid for asphalt cement and rejuvenating materials.

515.05.04 Responsibility for Asphalt Admix Design - As the Ministry is responsible for all pre-engineering for the project, preparation of the asphalt admix design is the responsibility of the Ministry. The Ministry shall provide to the Contractor, pre-engineering information related to the Asphalt Admix. All costs incurred in admix design formulation are the responsibility of the Ministry.

515.05.05 Evaluation of Asphalt Admix Materials - The Ministry Representative will require up to 5 calendar days upon notification from the Contractor to evaluate the Contractor’s Asphalt Admix materials.

515.05.06 Samples Required for Asphalt Admix Evaluation - At the discretion of the Ministry Representative, the Ministry may request samples of the Admix materials and Quality Control results and documentation for evaluation. Shipping costs for samples delivered to the Ministry Representative are the responsibility of the Contractor.

515.05.07 Field Adjustment of the Job Mix Formula and/or Recycled Pavement - During construction, the Ministry may require field adjustments to the job mix formula and/or recycled pavement. A field adjustment to the Job Mix Formula is defined as a change in the asphalt cement content of the admix, aggregate gradation, rejuvenating agent and/or proportioning of various aggregate sizes.

PART B - PAYMENT ADJUSTMENTS

515.11 Density

515.11.01 Coring - The Contractor shall be responsible for providing all core samples for quality assurance and payment adjustment purposes. The location of the cores shall be randomly selected and provided to the Contractor by the Ministry Representative. The Contractor shall provide 150 mm diameter cores for these purposes. The minimum core thickness shall be 37 mm. The Contractor shall prepare the cores prior to submission by removing all material not representative of the pavement lift to be tested. The Contractor shall deliver these cores to the Ministry Representative on site, within 24 hours of being provided the locations for the coring.

In the case of a core sample location falling in an obvious

non representative area, such as a previously patched area, at the sole discretion of the Ministry Representative, a new random core location will be chosen for that sample.

All costs associated with obtaining the cores, including the filling and compaction of the core holes are considered incidental to the contract and are the responsibility of the Contractor.

515.11.02 Percent Density - One random core sample will be obtained from each Sub-Lot and tested. The test results for the three Sub-Lots will be averaged to determine the percent density for the Lot.

$$\text{Hot-In-Place \% Density} = \frac{\text{In Place Density of Sample}}{\text{Maximum Theoretical Density}} \times 100$$

(ASTM D-2041)

The Maximum Theoretical Density for the lot will be determined by combining the Sub-Lot cores. Prior to testing to determine the maximum theoretical density, the cores should be prepared in accordance with the procedure outlined in Appendix 3.

515.11.03 Payment Adjustments - The payment adjustment for percent density will be the amount shown in Table 515-C for the Sample Mean of the test results for the Lot.

TABLE 515 C PAYMENT ADJUSTMENTS FOR DENSITY

% Maximum theoretical density lot average	payment adjustment (\$ per m²) for design lot
95.6 Plus	+ \$0.25
95.0 – 95.5	+ \$0.15
94.0 – 94.9	+ \$0.10
93.0 – 93.9	0.00
92.6 – 92.9	- \$0.10
92.0 – 92.5	- \$0.25
91.9 or less	Reject

515.11.04 Rejection Limit - The rejection limit for percent density is the limiting value of the Sample Mean as shown in Table 515 C.

If the test result for density of a Sub-lot is outside the acceptance limits, the Sub-lot is rejected automatically regardless of the values of other acceptance parameters. To minimize the cost of rejection to the Contractor, the Contractor shall isolate the area of low density within the Sub-lot and perform the necessary corrective measures to ensure specifications are met. The limits of the low density area must be verified and approved by the Ministry

Representative before remedial work proceeds.

515.11.05 Payment for Rejected Work Made

Acceptable - The payment adjustment for density will be based on testing of the reprocessed, replaced, or overlaid material where applicable. Where replacement or overlay material does not cover the entire Lot or Sub-Lot, prior tests of the uncovered area will be averaged with new tests on the corrective work.

515.12 Smoothness

515.12.01 Determination of Pavement Smoothness -

The finished pavement surface shall be tested by the Ministry using a Class I precision rolling profile measuring instrument, to determine the longitudinal profile and compute the International Roughness Index (IRI) in each driving lane. Profiles shall be measured and the IRI calculated in the centre of the lane for each Sub-Lot. IRI values will be recorded to a precision of 0.01 m/km for each Sub-Lot. The Lot IRI value is the average of the IRI values calculated for the Sub-Lots within the Lot.

For any Sub-Lot between 50 m and 100 m in length, the IRI value shall be considered representative of a complete Sub-Lot. For any Sub-Lot less than 50 m in length, the IRI value will be combined with the proceeding Sub-Lot IRI value.

The profile shall be measured over the entire length of the pavement exclusive of structures and shoulder areas. Acceleration, deceleration and turning lanes are considered part of the driving lanes and shall be tested in accordance with this provision. For the measuring process, the Contractor shall provide the Ministry Representative a chalk guide line in the centre of the lane immediately prior to measurement.

515.12.02 Auxiliary Lanes - For smoothness testing, sections of the driving lanes that do not fall within the continuous through lanes, such as acceleration lanes, deceleration lanes and turning lanes, and lanes which are less than 1 km in length, shall be treated as follows. The ratio of the section length to the standard Lot length of 1 km shall be determined and the payment adjustment shall be pro-rated on this basis as in the following example:

$$\text{Length of segment, } = \frac{0.565 \text{ times the Standard Lot}}{\text{i.e. 565 metres}} = \text{Length of 1000m.}$$

Hence the applicable payment adjustment is 0.565 times the payment adjustment for a 1-km Lot as determined from Table 515-D.

515.12.03 Acceptance Limits - The acceptance limit for smoothness is the limiting value as shown in Table 515-D, beyond which corrective work is required. Payment adjustments are shown in Table 515-D. The International Roughness Index (IRI) value, calculated for each Sub-Lot, will be used to determine if the Lot will be accepted, and if so whether it will be subject to any payment adjustment.

515.12.04 Payment Adjustments for Full or Increased Payment

- Acceptance of any Lot at full or increased payment will occur if it contains no obvious defects as per SS 515.22 and in the case of top lift pavement only, the pavement smoothness, as reported by the International Roughness Index (IRI) meets the following requirements:

- All Sub-Lots shall have an IRI value ≤ 2.0

515.12.05 Rejection Limit - If a Sub-Lot has an IRI >2.0 , the Sub-Lot is rejected.

515.12.06 Remedial Work - If the test results on a Sub-Lot of pavement indicate a payment reduction or rejection because of smoothness, the Contractor may propose remedial work to improve the smoothness. Such proposals are subject to the approval of the Ministry Representative, but such approval does not imply that the proposed remedy will be successful, and does not reduce the Contractor's responsibility for meeting the acceptance requirements. Reprocessing may be acceptable, but cold milling and repaving may be required. Only one attempt may be made to improve smoothness, and this must be completed within ten (10) calendar days from the time the Contractor receives notification from the Ministry Representative of the original smoothness test results for that Sub-Lot.

Following any attempt to improve the smoothness of a Sub-Lot or Sub-Lots, the Ministry Representative will retest the Sub-Lot or Sub-Lots, and the new results will replace the previous data for the purposes of determining acceptance and payment.

TABLE 515-D – LOT ASSESSMENT AND PAYMENT ADJUSTMENTS FOR SMOOTHNESS

For the final surface course only, the following payment adjustments shall apply to each Lot.

<u>Lot IRI (m/km)</u>	<u>Payment Adjustment</u>
≤ 1.00	+\$2,000
>1.00 and ≤ 1.10	+\$1,000
>1.10 and ≤ 1.20	+\$500
>1.20 and ≤ 1.30	+\$250
>1.30 and ≤ 1.40	0
>1.40 and ≤ 1.60	-\$300
>1.60 and ≤ 1.80	-\$750
>1.80 and ≤ 1.90	-\$1,500
>1.90 and ≤ 2.00	-\$2,500
>2.00	REJECT

No payment will be made for any material, equipment or manpower used to improve, or attempt to improve, smoothness.

515.12.07 Smoothness Deficiency Repairs - Smoothness deficiencies (bumps and dips) less than 8 mm over 3 m will not have a fix or remedial work requirement. Individual Smoothness deficiencies between 8 mm and 12 mm over 3 m will result in a \$200.00 penalty per deficiency and Smoothness deficiencies over 12 mm over 3 m will require remedial work. (see Subsection 515.22).

PART C - ACCEPTANCE AND REJECTION

515.21 Acceptance At Reduced Or Adjusted Payment -

Acceptance of any Lot at reduced payment will occur if it contains no obvious defects as per SS 515.22, and if:

- the test results for acceptance parameters are such that the Lot or Sub-Lot meets the requirements for acceptance at a reduced payment; and
- the Lot or Sub-Lot is approved in respect of all other requirements; and if
- the Contractor has not notified the Ministry Representative in writing that it will exercise its option to either repair or remove and replace the work, at its own cost, with work meeting the requirements for acceptance at full or increased payment.

515.22 Rejection For Workmanship Defects - The finished surface of any lift shall have a uniform "closed" texture and be free of visible signs of poor workmanship. Any obvious defects as determined by the Ministry Representative such as, but not limited to the following, will be cause for automatic rejection of asphalt pavement regardless of the values of any other acceptance parameter:

- individual bumps and dips that exceed 12 mm over 3 m.;
- areas of excess or insufficient asphalt;
- improper matching of longitudinal and transverse joints;
- roller marks;
- tire marks; or
- cracking or tearing.

When asphalt pavement is rejected by reason of obvious defects, the minimum area of rejection will be the actual length of the defect for the full width of the driving lane in which the defect exists.

Rejected work shall be promptly repaired, remedied, or removed and replaced in a manner acceptable to the Ministry Representative. The Contractor shall be responsible for all costs including materials.

No payment will be made for work in any Lot or Sub-Lot, which has been rejected, until the defects have been remedied.

515.23 Appeal Testing

515.23.01 Density - The Contractor may appeal the results of acceptance testing for density for any lot only once. Appeals will only be considered if quality control results can be presented to support the appeal.

Quality control test results for density which are provided to the Ministry Representative subsequent to the Contractors receipt of the quality assurance test results for that Lot will not be considered (when evaluating evidence) for an appeal. The appeal shall be for all tests within the Lots, and there will be no appeal allowed for single tests within the Lot.

The following procedures will apply for the appeal:

- The Ministry Representative will arrange for an independent testing laboratory to perform the appeal testing. The personnel employed or testing laboratory retained by the Contractor for quality control testing on the project will not be used for appeal testing.
- The original quality assurance results will not be considered in the appeal. The Contractor will sample the pavement at locations randomly re-selected by the Ministry within three site occupancy days following receipt of the appeal such that a total of (5) new core specimens are extracted throughout the Lot. The Ministry Representative will observe the sampling process. The procedures used to determine the test results shall be consistent with the original acceptance testing methods.

515.23.02 Smoothness - The Contractor may appeal smoothness acceptance test results of any rejected or penalised Lot, once. The appeal shall be in writing and submitted within the next three site occupancy days following receipt of the test results.

Any attempt to improve smoothness on the appealed Sub-Lot after the Ministry Representative has tested the Lot for acceptance shall void the appeal and the original test results will apply.

The Ministry Representative will perform, and the Contractor will be given the opportunity to witness, the appeal testing and the new results will be binding on the Contractor and the Ministry.

515.23.03 Application of Appeal Testing Results - For density appeals, the original test will be discarded. A new Sample Mean for the five new test results will be determined and used for acceptance and payment adjustment.

The new values, thus determined, in all cases, will be binding on the Contractor and the Ministry.

515.23.04 Payment for Appeal Testing - If the new

results indicate a change in the payment adjustment in the Contractor's favour, then sampling and testing costs incurred during the appeal procedures for that Lot will be borne by the Ministry.

If the new results verify that any payment reduction or rejection remains valid for that Lot, then the costs of sampling and testing (plus 10% mark-up) incurred during the appeal procedure will be charged to the Contractor.

515.23.05 Time Limits for Appeals of Test Results - All appeals shall be in writing and submitted within the next three site occupancy days of receipt of the test results.

515.24 Cold Milling And Re-Paving As A Corrective Measure - If cold milling and re-paving is used as a corrective measure on a defective Lot or Sub-Lot, the thickness will be subject to the approval of the Ministry Representative, but shall not be less than 40mm. In all other respects, the re-paving will be subject to the same specifications as the pavement being replaced.

Whether the cold milling and re-paving is applied as a corrective measure, acceptability and payment will be determined as follows:

- acceptability, and eligibility for either positive or negative payment adjustment, will be determined entirely on the results of testing and observations conducted on the re-paving, regardless of test results that have been obtained on the hot-in-place recycled pavement;
- the payment quantity, for application of the Unit Prices for asphalt pavement, and the quantity, to which any payment adjustment is to be applied, will be derived from the square meters of recycled pavement affected by the re-paving.

PART D - PAYMENT

515.31 General - Payment at Unit Prices for the supply of virgin aggregates, the supply of asphalt cement, the supply of rejuvenating agents, the supply of virgin asphalt mix and the Hot In Place recycling construction of asphalt pavement, shall be full compensation for completing the supply and installation of Hot-In-Place asphalt pavement on prepared surfaces in accordance with the contract requirements. Applicable payment adjustments (Additions or subtractions as applicable) shall be applied in accordance with Part B of this Section

The first 4,000 m² of hot in place asphalt pavement recycling production will not be subject to bonus/penalty payment adjustments but will be required to meet minimum Specification requirements for quality and workmanship.

515.31.01 Rejuvenating Agent and Asphalt Cement -

Rejuvenating Agent - Payment to Supply Rejuvenating Agent shall be at the Unit Price per litre for the quantity of material actually metered into the recycling process.

Such payment shall be full compensation for supplying, handling, storing, heating, sampling, testing and blending the material and all other related work.

Asphalt Cement - Payment for Supply of Asphalt Cement for admix shall be at the Unit Price per tonne for the payment quantity determined from:

$$\frac{\text{Payment Quantity of Asphalt Cement} = \text{Av. Actual Asphalt Content} \times \text{Payment Quantity of Asphalt Admix}}{\text{Average Actual Asphalt Content} + 100}$$

Where: **-Payment Quantity of Asphalt Admix** is the quantity determined in accordance with SS 515.31.03,

-Actual Asphalt Content is as defined in SS 515.03.04,

The actual asphalt content shall be determined on a Lot by Lot basis by averaging the values obtained from the Quality Control tests from each Lot. This average will be used to determine the tonnage of Asphalt Cement used for payment purposes for the Asphalt Cement for the Lot.

The quantity of asphalt cement so determined shall be used for payment purposes regardless of any discrepancy that may be noted between it and any quantity calculated using delivery quantities, tank dips, or other data. No payment will be made for asphalt cement used in reject mix.

Such payment shall be full compensation for supplying the material to the project, handling, storing, heating, sampling, and testing of the material, and other related work.

515.31.02 Paving Aggregate into Stockpile – EPS -

Payment for Paving Aggregate into Stockpile - EPS shall be at the Unit Price per tonne for the quantity of paving aggregate placed into stockpile accordance with the following:

- The paving aggregate quantity will be identical to (100%) of the asphalt admixture quantity. As the aggregate is crushed into stockpile, progress payments will be made against the bid item, up to the quantity shown in the "Approximate Quantity" column of the Schedule of Approximate Quantities and Unit Prices. At contract completion, the final payment quantity for asphalt admix aggregate in accordance with the following calculation:

$$\frac{\text{Tonnes of Asphalt Admix Aggregate} = \text{tonnes of mix} \times 100}{100 + \text{actual calculated asphalt content as per SS 515.03.04}}$$

Such payment shall be full compensation for all work including but not limited to the production, supply and stockpiling of all paving aggregates, and shall include all costs of quality control.

515.31.03 Asphalt Admix – EPS - Payment for Asphalt Admix - EPS constructed in place shall be at the Unit Price per tonne for the quantity of admix placed in accordance with the Contract requirements.

SECTION 515

HOT-IN-PLACE RECYCLED ASPHALT PAVEMENT CONSTRUCTION (EPS)

Subject to the exception noted below, only acceptable asphalt admix will be included in the payment quantity.

Where cold milling and re-paving is used as a corrective measure, in accordance with SS 515.24;

- the overlay quantity will not be included in the admix payment quantity, but
- the admix used in quantity of recycled pavement removed by the cold milling and re-paving will be included in the admix payment quantity, whether or not it was acceptable.

Such payment shall be compensation in full for all work including but not limited to: loading the aggregate into the feeders, drying the aggregate, metering and adding the asphalt cement, mixing, loading, weighing, hauling, dumping, spreading, compacting and finishing the asphalt pavement, and shall also include all costs of quality control.

515.31.04 Hot-In-Place Recycled Asphalt Pavement – EPS - Payment for Hot-In-Place Recycled Asphalt Pavement - EPS constructed in place shall be at the Unit Price per square meter for the quantity of recycled pavement in accordance with the Contract requirements.

Subject to the exception noted below, only acceptable recycled asphalt pavement will be included in the payment quantity.

Where cold milling and re-paving is used as a corrective measure, in accordance with SS 515.24;

- the overlay quantity will not be included in the admix payment quantity, but
- the admix used in quantity of recycled pavement removed by the cold milling and re-paving will be included in the admix payment quantity, whether or not it was acceptable.

Such payment shall be compensation in full for all work including but not limited to: recycling, metering adding the rejuvenating agent, adding, spreading, compacting and finishing the asphalt pavement, and shall also include all costs of quality control.

515.31.05 Payment for Acceptable Work - The following end product properties of recycled asphalt pavement will be measured for acceptance:

- Density
- Smoothness

515.31.06 Payment for Rejected Work Made Acceptable - When defects have been remedied in Lots or Sub-Lots which had been rejected, payment for the original quantity of material in those Lots or Sub-Lots will be made subject to payment adjustments and penalty assessments and subject to Subsection 515.24.

No payment will be made for any material used to replace,

repair or overlay rejected work and all corrective work shall be performed entirely at the Contractor's expense.

515.31.07 Payment Adjustment - Payment adjustments resulting from the application of this Section will be effected on each progress payment as follows.

a) For each Lot paid for by the square metre (m²), the applicable payment adjustment derived from Table 515-C (Density), in dollars per square metre will be expressed as positive in the case of increases and negative in the case of decreases. The algebraic sum of these unit adjustments will then be applied to the payment quantity for the Lot. The resulting amount, in dollars, will be the net payment adjustment, positive or negative, for that Lot.

The algebraic sum of the net payment adjustments for all such Lots for which payment is authorized on the current progress payment, computed in dollars, shall be the total payment adjustment for density for the current progress payment.

b) For each Lot, the applicable payment adjustment derived from Table 515-D (Smoothness), in dollars per Lot, will be expressed as positive in the case of increases and negative in the case of decreases, and will be the payment adjustment, positive or negative, for that Lot.

The algebraic sum of the payment adjustments for all such Lots for which payment is authorized on the current progress payment, computed in dollars, shall be the total payment adjustment for smoothness for the current progress payment.

c) The algebraic sum of the total payment adjustments for density and smoothness, derived in accordance with 1 and 2 above, shall be the total payment adjustment, positive or negative, in dollars, for all attributes for the current progress payment. This amount shall be added, if positive, or subtracted, if negative, by a single entry in computing the current progress payment.

d) The process set out in a) to c) above will be used in computing each progress payment to which it is applicable.

515.32 Surplus Aggregate In Stockpile - At the discretion of the Ministry Representative, the Ministry may or may not purchase surplus aggregate in stockpile in a private pit. Generally the Ministry will provide payment for the processing costs of surplus aggregate in stockpile in Ministry Pits only, and only to a limited quantity. However, should the Contractor produce surplus aggregate in a private pit, and the Ministry intends to purchase these surplus aggregates, the Contractor shall be required to provide a written agreement with the owner of the property. This document shall indicate that the Ministry will have free access to and use of the surplus aggregate in stockpile for a period of 12 months after the completion of the contract work. If the Contractor undertakes private work from within the private pit, measurements for surplus

aggregate in stockpile will not be taken until the completion of the private work, ensuring that the Ministry does not pay for aggregate used on private works.

All surplus aggregate shall be properly stockpiled.

515.32.01 Ministry Purchase of Surplus Aggregate -

Should the Ministry proceed with the purchase of surplus aggregate, upon completion of the contract, the Ministry will purchase surplus paving mix aggregate as indicated herein. Surplus crushed base and/or shoulder aggregates shall be paid for according to Section 502.

If the quantity of Asphalt Pavement actually incorporated into the works is less than the estimated quantity, as stated in the Schedule of Approximate Quantities and Unit Prices, the Ministry will purchase surplus aggregate up to

100% of the quantity required by the contract. The surplus aggregate must, when singly or combined, meet the gradation requirements set out in the Job Mix Formula.

The maximum total surplus aggregate to be purchased will be the quantity of aggregate required to produce the quantity of mix as stated in the Schedule of Approximate Quantities and Unit Prices minus the quantity of aggregate actually incorporated in the works.

No payment shall be made for any surplus aggregate remaining at contract completion in excess of the contract requirement. Material remaining in the pit is the property of the Ministry.

APPENDIX 1

QUALITY CONTROL REQUIREMENTS AND GUIDELINES

1.01 GENERAL

The Contractor's responsibilities for preparing, submitting and adhering to a Quality Control Plan are specified in SS 515.04. This Appendix provides requirements and guidelines for the Contractor's Quality Control Plan, in addition to those set out in SS 515.04.

1.02 QUALITY CONTROL PLAN

As a requirement, the Contractor shall prepare and submit a Quality Control Plan for evaluation. The Plan may be operated wholly, or in part by a qualified Subcontractor or an independent organization/agency. However, the Quality Control Plan, including compliance with the Plan and its modifications, is the responsibility of the Contractor.

The Plan shall address all elements that affect the quality of the hot in place recycled asphalt pavement, including but not limited to the following:

- Supply of Asphalt Materials
- Supply of rejuvenating agents
- Identification of source and proof of quality of virgin aggregates to be supplied;
- Virgin aggregate production and its gradation control;
- Quality of virgin aggregate components;
- Stockpile management;
- Asphalt plant calibration and proportioning of aggregate components;
- Mixing including asphalt cement content control;
- Process temperature controls;
- Admix Material and Rejuvenating Agent application rates and processed dimensions, placing and finishing;
- Joints;
- Density;
- Smoothness;
- Segregation;

The plan shall also include the following:

- The name of the Quality Control testing agency and its proven capability to provide the specific services required for the project.
- The list of dedicated technical staff, if available, (including names, qualifications and relevant experience) and their proposed roles.

The list of testing equipment available for project work.

The Quality Control Plan shall include the designation of

specific personnel responsible for specific quality control duties.

- There shall be a designated Quality Control Manager, as per SS 515.04.03. The Quality Control Manager shall be qualified as per SS 515.04.03. The Quality Control Manager shall be responsible for the preparation and sign off of the Quality Control Plan, responsible for all Quality Control testing, and inspections, responsible for the sign off of all quality control testing and inspection records and responsible for all quality control submissions to the Ministry. The individual shall be identified and named in the Quality Control Plan submission. If the Contractor requests a change in the Quality Control Manager, then a formal request to the Ministry Representative shall be made and the Ministry will review the request for approval.
- There may be a designated Process Control Technician (PCT) who would be responsible to ensure that laboratory test results and other quality control practices are used to control the quality of aggregates and other mix components and to adjust and control mix proportions to meet the mix design(s). The PCT is responsible for ensuring that testing equipment, utilized for proportioning and mixing are calibrated and in good working order. The Plan may describe how the PCT's duties, including sampling methods and responsibilities are to be accomplished and documented. The Plan should also describe the criteria to be used by the PCT to correct or reject unsatisfactory materials.
- There may also be a Pavement Quality Control Technician (PQT) who would be responsible to ensure that delivered materials meet the requirements of the specifications. In addition, the PQT shall be responsible for periodically inspecting all equipment used in recycling, placing, finishing, and compacting to assure its proper operating condition and to assure that recycling, placing, application rate, finishing, joint construction, and compaction is in conformance with this specification and the contract requirements.

1.03 CONTRACTOR'S RECORD OF QUALITY CONTROL TESTING

Test results shall be made on specified forms or charts immediately after completion of each test. These test results are to be made available to the Ministry Representative upon request.

Records of gradation control, both during aggregate production and also during the asphalt mixing operation, should be kept on the form H-295 - Mechanical Analysis of Aggregates.

1.04 MATERIALS APPLICATION RATE

The Contractor shall control the Material Application Rate by monitoring the amount of asphalt admix delivered to the road against the area covered by checking the application rate every five loads.

The Contractor shall monitor the addition of rejuvenating agents by calculating the application rate, through comparing the metered amount with the total area processed every one-half hour.

The Contractor is to advise the Ministry Representative on an ongoing basis of the application rates.

1.05 DENSITY

The Contractor shall take core samples to determine actual pavement density. At the start of paving, the Contractor

may take a minimum of two pavement cores from each Sub-Lot. The Contractor may employ a nuclear densometer to ensure intermediate density control.

1.06 OTHER QUALITY CONTROL PROCEDURES

The Contractor may initiate other Quality Control procedures as necessary for ensuring production of a quality product and include them in the Quality Control Plan. Procedures may also be introduced after the start of work as necessary as amendments to the Quality Control Plan.

1.07 QUALITY CONTROL TESTING FREQUENCY GUIDELINES

Test frequency guidelines for Quality Control are described in TABLE 1:

TABLE 1 –TEST FREQUENCY GUIDELINES

	Test	Minimum Frequency
Tests During Crushing (Virgin Aggregate)	ASTM C 136, Dry Sieve Analysis of Aggregate	Split Stockpiles: One for each stockpile for every 2 hours of production. One main stockpile: for every 300 tonnes. Blend Sand: One for every 100 tonnes during stockpiling. Natural filler: One for every 50 tonnes during stockpiling.
	ASTM D 5821 Determining the Percentage of Fractured Particles in Coarse Aggregate	Every second coarse aggregate sieve test.
	ASTM C 117 Sieve Analysis of Aggregates by Washing (Field Lab)	One per day on reduced sample obtained from combined samples from the crusher
Tests During Asphalt Plant Mixing (Admix)	ASTM C 136, Dry Sieve Analysis of Aggregate	One of combined aggregate every 100 tonnes.
	ASTM C 566 & D 2216, Moisture Content	Aggregate: 2 tests/Lot Asphalt mix: 1 on first Sub-Lot and every second day.
	ASTM C 117 Sieve Analysis of Aggregates by Washing (Field Lab)	One per shift on reduced sample obtained from combined samples from the plant cold feed
	Asphalt Extraction Test ASTM D 6307 Ignition Method	One per Lot.
	Penetration of Bituminous Materials ASTM D 5	One per Manufacturer's Batch
	Viscosity ASTM D 2171	Contractor's Option
Rejuvenating Agents Tests	Rejuvenating Agent	Contractor's option.
Test During Asphalt Paving for Density Testing (Hot In Place Recycled Pavement)	ASTM D 1559, Resistance to Plastic Flow of Bituminous Mixtures Using Marshall Apparatus	Contractor's Option
	ASTM D 2726 Bulk Specific Gravity and Density of Non-Absorptive Compacted Bituminous Mixtures (Briquette or Cores)	One per Sub-lot
	ASTM D 2041 Theoretical Maximum Specific Gravity of Bituminous Paving Mixtures	One (see Appendix 3 for Combining Cores)
	Core Samples	One core for each Sub-Lot. All cores to be 150mm diameter.

APPENDIX 2

REQUIREMENT FOR PRODUCTION OF ADMIX AGGREGATES

2.01 GRADATION MAXIMUM PERMISSIBLE VARIATION LIMITS:

Sieve Size	Variation
19.0 mm or 16.0 mm	0%
12.5 mm	+/-3.5%
9.5 mm	+/-3.5%
4.75 mm	+/-3.0%
2.36 mm	+/-3.0%
1.18 mm	+/-2.0%
0.600 mm	+/-2.0%
0.300 mm	+/-1.5%
0.150 mm	+/-1.0%
0.075 mm	+/-0.75%

The variation limits, when applied to the Ministry specified design Admix gradation, shall not result in a gradation that is outside of the limits as specified by the Ministry.

APPENDIX 3

METHOD TO COMBINE ROAD CORES INTO A SINGLE COMBINED SAMPLE FOR THE DETERMINATION OF MAXIMUM THEORETICAL DENSITY.**3.01 INTRODUCTION**

After the individual Density for each core has been determined, the Sub-lot road cores shall be combined into one single sample for the determination of maximum theoretical density.

3.02 SAMPLE PREPARATION

The upper re-cycled portion of the cores shall be separated from other pavement layers by sawing or other effective methods.

The minimum combined sample size required shall be 2000 grams and 2500 grams for 19.0 mm and 25.0 mm maximum aggregate size respectively.

Select a core trimmer to ensure that the minimum sample size is obtained depending on the thickness of the samples. 100 mm, 114 mm, or 127 mm core trimmers may be used.

Place the core samples in a pan and heat to $130^{\circ}\text{C} \pm 5^{\circ}\text{C}$ for about 20 minutes to allow the specimens to be easily trimmed. Do not overheat. The cores can be stacked on top

of each other and trimmed together or individually.

Select a core trimmer to attain the minimum combined sample size. Heat the base of the trimmer by placing on a burner for a few minutes.

Centre the heated trimmer on the heated cores (allow equal clearance on all sides of the core).

Hold the trimmer vertically by its handle, then press it down through the core until it reaches the bottom of the pan. Apply a slight twist if the heated cores(s) are difficult to penetrate.

Remove the outside cut rock mix by means of a spatula spoon and discard.

Thoroughly mix the resultant combined sample prior to testing to ensure uniform aggregate coating.

The complete combined sample must be tested. If the resultant sample size exceeds the available capacity of the container used for vacuum saturation, it may be tested a portion at a time.

SECTION 521

ASPHALT STABILIZED BASE COURSE MIXED IN PLACE

DESCRIPTION

521.01 Scope - This Section describes the materials, plant, equipment and work practice required for the in place stabilization of granular base course material mixed with selected bituminous binder.

EQUIPMENT

521.21 General Condition of Plant and Equipment

521.21.01 The Contractor, when submitting the bid for work under this contract shall at the same time submit a list of equipment available and ready for use on the contract, and shall further certify that the equipment listed meets the requirement of this Section in every respect.

521.21.02 Before any work is permitted to commence, the Contractor's equipment and plant will be carefully inspected; should any of it fail to meet the required standards, work will not be permitted to commence until such deficiency is corrected.

521.21.03 All equipment and plant shall be in good mechanical condition and adjustment and be capable of efficiently performing the work required of it.

521.21.04 Once the Contractor's bid has been accepted, provision and maintenance of all equipment listed shall become an essential part of the contract and no equipment or plant may be released from the contract work for use elsewhere until completion, except by the express written permission of the Ministry Representative.

521.21.05 The Ministry Representative shall have access at all times to any plant, equipment or machinery to be used on this contract in order to check calibration, control or operating adjustments. Where adjustment appears necessary, it shall be done by a competent technician or instrument repair laboratory.

521.21.06 Plant, machinery and equipment specified hereafter shall represent a minimum requirement for the type of machine described and does not represent a comprehensive list of equipment to be supplied by the Contractor, who shall supply whatever plant and equipment may be necessary to the proper and efficient completion of the work.

521.21.07 All plant and equipment shall be under the control of experienced and skilled operators.

521.22 Pressure Distributor - The pressure distributor used for applying bituminous materials shall consist of a fully insulated tank with a minimum capacity of 5000 ℓ permanently and rigidly mounted on a truck or trailer provided with pneumatic tires and propelled by a power unit capable of maintaining a constant and uniform speed. In order to be acceptable, the distributor shall be provided with the following minimum equipment:

a) quick opening gate in the dome.

b) a measuring dipstick calibrated in 100 ℓ increments or in 20 mm gradations and provided with a calibration chart indicating the number of litres for each 20 mm in depth of contained bituminous material for accurate checking of the distributor contents. In addition an external and readily visible depth gauge or levelometer indicating the asphalt content of the tank to the nearest 100 ℓ and having an accuracy of ± 50 ℓ.

c) an efficient and positive means of heating the bituminous contents uniformly to any temperature up to 175°C and maintaining the contents constantly at any selected temperature without any local overheating.

d) an approved industrial type thermometer so situated that its face shall always be readily visible to the spray bar operator. The sensing element of the thermometer shall be placed either directly in contact with the hot bituminous material or enclosed in a thin walled well of approved manufacture, so placed as to accurately measure the temperature of the material in the tank. The thermometer shall have a minimum range of 10° to 175°C subdivided into 1°C gradations and be accurate to ± 0.5 °C

e) rear mounted spray bars and nozzles set parallel to the surface to be sprayed and capable of vertical and lateral adjustment. The spray bars shall be capable of adjustment to provide a minimum spraying width of 1.8 m and a maximum spraying width of 7.5 m.

The feed to the spray bars must be so arranged that there shall be a constant circulation of hot bituminous material to the bars such as will ensure a uniform viscosity and constant pressure of the bituminous material at each nozzle, both before and during spraying operations. Feed manifolds to spray bars shall be provided with strainers to prevent clogging of bars and nozzles.

f) rotary adjustable, spray bar nozzles which shall be so designed and set as to ensure a uniformly fan shaped spray without atomization, overlapping on the surface to be sprayed, such that there shall be produced a uniformly sprayed surface to clearly defined edges of the sprayed lane without any reduction of the rate of application adjacent to the edges of the lane. Spray nozzles shall be provided with valves capable of instant full opening or positive cut-off.

g) a connection to a circulating pressure manifold to which a hose may be attached for a single nozzle, hand operated outlet.

h) a pressure gauge accurate to 15 kPa and calibrated pressure pump, equipped with a tachometer registering litres per minute and driven by an independent mechanically governed power unit, so designed as to be

capable of applying through the spray nozzles fitted, accurately measured quantities of bituminous material at a minimum rate of 900 ℓ per minute.

Both pressure gauge and tachometer shall be mounted so as to be readily visible to the operator.

i) a fifth wheel tachometer, registering metres per minute and so calibrated and mounted as to be readily visible to the driver of the distributor, to enable the operator to maintain the constant speed required for application of bituminous material to the road at the specified rate.

521.23 Blade Graders - Self-propelled blade graders mounted on pneumatic tires shall be of approved modern type, either four wheel drive or tandem type having sufficient capacity to efficiently perform all work that may be required on the contract. Unless otherwise approved by the Ministry Representative, all graders shall meet the criteria listed in Table 521-A.

521.24 Pulverizing and Rotary Mixing Machines - Pulverizing and rotary mixing machines to be used on the work shall be standard machines, factory produced by a reputable manufacturer, so designed and constructed as to satisfactorily break up all base aggregations into constituent particles and capable of thoroughly and uniformly mixing the granular base material and applied asphaltic binder so as to produce a uniformly coated mix free from lumps, balls or segregation. The Contractor may use any machine of the Contractor's choice, subject to the approval of the Ministry Representative.

521.25 Compaction Equipment - Compaction equipment shall consist of approved steel wheel rollers, pneumatic tired rollers, vibrating rollers or tampers.

521.25.01 Self Propelled Steel Rollers - Self propelled steel rollers may be three-wheel rollers or tandem rollers. These rollers shall be equipped with power units of not less than four cylinders unless otherwise approved by the Ministry Representative, and under working conditions shall be capable of developing a compression in the rear wheels of not less than 4.0 kg/mm² over a minimum roller width of 500 mm. At least one roller on each job shall be capable of developing a roll pressure of 4.5 kg/mm² of width. Rollers shall be in good working condition and free from backlash, faulty steering mechanism or worn parts. Rollers shall be equipped with adjustable scrapers to keep the rolls clean and with an efficient means of keeping the wheels wet to prevent mixes from sticking to the rolls. Rolls shall be free of flat areas, dents, openings or projections which will mar the surface of the pavement.

521.25.02 Pneumatic Tire Rollers - Pneumatic tire rollers shall be either self-propelled or towed type, single or double axle, having a minimum effective rolling width of 1.2 m. The rollers shall be equipped with smooth tread pneumatic tires of equal size and diameter. The wheels of the roller shall be so spaced that two passes of a single axle roller or one pass of a two axle roller will accomplish one complete coverage equal to the rolling width of the

TABLE 521-A CRITERIA FOR BLADE GRADERS

Minimum Weight	7.25 t
Minimum Blade Length	3.6 m
Minimum Wheel Base	5.5 m
Minimum Cubic Displacement of Pistons: 4 Cycle Motors	7.0 ℓ
Minimum Cubic Displacement of Pistons: 2 Cycle Motors	4.0 ℓ

machine. There shall be a minimum 6 mm overlap of the tracking wheels of a double axle roller. The wheels of towed rollers to be used on granular base preparation may wobble. The roller shall be so constructed that the contact pressure shall be uniform for all wheels and the tire pressure of the several tires shall not vary more than 35 kPa. Pneumatic tire rollers shall be constructed with ample ballast space to provide an operating weight of 4.5 to 8 kg/mm² of tire track width. The total operating weight of the roller may be varied by the Ministry Representative. The towing vehicle for towed type roller shall be equipped with smooth tread pneumatic tires.

521.25.03 Vibrating Tampers - Vibrating tampers to be used for the compaction of bituminous base in places inaccessible to rollers, shall be of a type suitable for the work to be performed and shall be subject to the approval of the Ministry Representative.

521.25.04 Vibrating Compaction Equipment - The Contractor may use vibrating compaction equipment to compact the stabilized base, provided that such equipment produces compaction and surface finish equal to that obtainable by using a steel wheel finish roller having a minimum compression roll pressure of 4.5 kg/mm².

CONSTRUCTION

521.31 Method I - When the roadway has been completed in its entirety by others, the following method shall apply:

a) The granular base shall be regraded to true line, grade and cross-section; the top 65 mm of the base shall be loosened by means of scarifying. The lumps of bonded material are to be broken to constituent gravel by harrowing, blading or rotary tilling. The loose material is to be bladed into a windrow, approximately 10 cm in height on both sides of the road. This windrow will act as a dam in case of spillage or the occurrence of rain after the spraying has taken place.

b) The prepared gravel surface shall be primed on the side not obstructed by the windrow, to the outside width required at a rate of 1 to 1.5 ℓ/m² or as may be ordered, employing the bituminous binder selected by the Ministry Representative within a spraying temperature range which corresponds to a kinematic viscosity of 150 to 200 mm²/s in the binder.

Priming shall be applied only when the surface is dry or slightly damp, and unless otherwise permitted by the Ministry Representative, when the air temperature in the shade is not less than 10°C rising or 12°C falling. When the prime has been completely absorbed by the prepared surface, blade the windrow of loose surface course onto the primed half of the road and prime the untreated half of the surface in a like manner.

Generally, this work shall be governed by the applicable provisions of SS 502.21.

c) Immediately prior to application of the bituminous binder, the windrow of loose gravel shall be bladed across the road to a full width uniform cross section. If wet or damp, it shall be first bladed back and forth until dry unless an emulsion is to be used. Cutback bituminous binder shall not be applied until the moisture content has been reduced to 1.5%. In the case of emulsions, mixing may commence when the moisture content of the gravel has been reduced to 4%.

No asphaltic binder shall be sprayed on the granular aggregate unless the average temperature of the aggregate on the road is 13°C or higher and such temperature can be maintained in the aggregate until the full mixing cycle has been completed.

Upon the layer of graded aggregate, the bituminous binder shall be applied uniformly at a rate of 1.35 ℓ/m², at application temperature required to produce a kinematic viscosity of 150 to 200 mm²/s in the binder.

A disc harrow or rotary type mixer shall immediately follow the distributor after the application of the bituminous binder and shall continue to operate on the treated strip until all free bituminous material has been mixed into the mineral aggregate. The treated mixture shall then be further mixed with a blade grader until a thoroughly uniform mixture results.

The mixture shall then be spread uniformly across the road once more, a second uniform application of bituminous binder at a rate of 0.9 to 1.8 ℓ/m² as may be directed by the Ministry Representative shall be sprayed at application temperature so as to give a final asphalt content of 4 to 6% of the mix. The second application of bituminous binder shall be mixed with the mineral aggregate in a similar manner to the first application, taking care that during the blade mixing none of the untreated base below the prime or shoulder material is brought into the mix. Blade mixing shall be continued until the bituminous binder and mineral aggregates are thoroughly mixed to uniform colour, free from fat spots, balls and uncoated particles. If the mixture should become wet before the mixing process is complete, the mixing operations shall be continued until it has dried out. After final mixing, the mixture shall be brought to a single windrow.

d) Before the finished mixture is finally spread for compaction, a triangular cut shall be made with a blade at each edge of the base course to provide for a thickened

edge of bituminous mixture. The cut shall be approximately 50 mm deep at the outer edge and slope to zero, 0.6 m in toward the centre. In making the cut, the excavated material shall be thrown to the shoulder in a small windrow against which the mixture shall be spread. The bituminous mixture shall be spread for compaction from the large windrow. It shall be bladed from this windrow in a succession of thin layers to correct thickness and a uniform cross section with a camber of 1 in 45 (except at curves, where the correct superelevation originally set for base shall be followed).

After the mixture has been spread as specified, it shall be compacted by means of rollers, which operation shall begin at the edges of the course and progress toward the centre parallel to the centreline of the roadway, overlapping in successive passes by at least one-half the width of the roller. Initial breakdown compaction may be obtained by use of steel or rubber tired rollers until no appreciable surface movement or roller marks are visible and the surface has been satisfactorily sealed. Final rolling to eliminate rubber tire or other marks and irregularities shall be carried out using an approved steel wheel finish roller or steel wheel vibrating rollers or other satisfactory equipment.

Compaction shall be carried out to the satisfaction of the Ministry Representative.

Should unsatisfactory areas develop during compaction, they shall be corrected as directed by the Ministry Representative.

521.32 Method II - When the granular base and base stabilization are included in the contract, Method II shall apply as described hereunder:

a) The first lift of granular base, 90 mm, shall be hauled to the roadway, spread, graded to line, grade and cross-section, compacted to 100% of the density as obtained in the laboratory following ASTM D 698.

On completion of the above roadways, as described in the foregoing, priming may be commenced.

On completion of priming and curing the second lift, 60 mm of granular base may be hauled to the primed roadway and spread in a uniform windrow and mixing commenced as described in SS 521.31(c).

On completion of base stabilization, the remaining granular base may be applied, i.e., from the edge of the stabilized base to the shoulder.

MEASUREMENT

521.81 Spray Asphalt - Spray asphalt will be measured by the LITRE sprayed on the road.

521.82 Process Base Gravel - Process base gravel will be measured by the SQUARE METRE of completed surface, constructed to dimensions ordered.

PAYMENT

SECTION 521

ASPHALT STABILIZED BASE COURSE MIXED IN PLACE

521.91 Payment - Payment for asphalt stabilizing granular base course in place will be made as follows:

a) Spray Asphalt - Payment for SPRAY ASPHALT will be at the Contract Unit Price per litre for the actual number of litres sprayed on the road converted to its volume at 15.6°C. The rate for spraying asphalt shall cover acceptance of asphalt at points of delivery, storing, heating, transport, spraying, traffic control, labour, superintendence, equipment and machinery required to carry out all asphalt spraying work including priming described in this Section.

b) Process Base Gravel - Payment for PROCESSING BASE GRAVEL will be at the Contract Unit Price per square metre of measured completed surface, constructed to dimensions ordered. Payment will not be made for extra width of surface mixed or compacted beyond the

limits specified.

The rate for processing base gravel shall cover provision of all tools, labour, equipment and services required to cut, shape, dry, pulverize, mix and lay out the base; all compaction; warning signs, barriers, lights, traffic control and superintendence required to thoroughly mix and compact the asphalt and aggregate in place on the road.

Payment of measured quantities at the bid rates for the above two items shall be full compensation for all work and services performed and materials and equipment supplied to complete asphalt stabilization of granular base course material according to the description and intent of this Section.

SECTION 531

ASPHALT SURFACE TREATMENTS

DESCRIPTION

531.01 Scope - This Section specifies the materials, plant, equipment and quality of work required for the construction of asphalt surface treatments with cover aggregates.

531.02 Description of Work - Surface treatment shall consist of the application of a selected asphalt binder material to a previously constructed bituminous pavement, or a well compacted crushed granular surface followed by the application and embedment of a course(s) of selected aggregate to provide a new surface which shall be impervious to moisture, have a non-skid texture, high luminosity and good riding qualities. This normally would be a graded aggregate seal or a coarse sand seal or any other surface treatment outlined in the Special Provisions for the Project work of the Contract.

531.04 Types of Graded Aggregate Seals - There are six types of graded aggregate seals as characterized by the maximum and minimum gradations of the cover aggregate as defined in SS 531.17.

asphalt binder proposed for use on the Project will be specified in the Special Provisions.

531.12 Coating and Anti-Stripping Additives - For general use or for experimental or trial purposes, the Ministry Representative may direct the use of surface active "coating and anti-stripping additives" or any other materials formulated to improve the coating and adhesive properties of the asphalt binder to the selected cover aggregate. In such cases, instructions concerning the type of additive to be supplied and the method of incorporation with the asphalt binder will be specified in the Special Provisions or, if the work has commenced, will be the subject of supplementary written instructions to the Contractor.

531.13 Mineral Aggregate Supply - Mineral cover aggregate meeting the requirements described hereunder shall be supplied by the Contractor unless specifically described otherwise in the Special Provisions.

531.14 Mineral Aggregate - Method of Test - Mineral Aggregate will be tested in accordance with the standard British Columbia Ministry of Transportation (BCH) and ASTM tests listed in Table 531-A.

531.15 Mineral Aggregate - Physical Requirements

531.15.01 Composition - Mineral cover aggregate shall consist of clean, sound, hard, durable particles or fragments of sand, gravel or crushed stones or combination thereof; containing a minimum of thin

MATERIALS

531.11 Asphalt Materials - Asphalt(s) to be used on surface treatment may be standard rapid curing cutback asphalt; medium curing cutback asphalts; or anionic or cationic emulsions including high float emulsified asphalts meeting the requirements of SS 951. Types and grades of

TABLE 531-A TEST METHODS FOR MINERAL AGGREGATE

BCH TEST	ASTM	NAME OF STANDARD TEST METHOD for
	D 75	Sampling stone, slag, gravel, sand, and stone block for use as Highway materials
	C 136	Sieve Analysis of Fine and Coarse Aggregates
	C 117	Materials Finer than 75 μ m (No. 200) Sieve in Mineral Aggregates by Washing
	C 142	Clay Lumps and Friable Particles in Aggregates
	C 127	Bulk Relative Density and Absorption of Coarse Aggregates
	C 128	Bulk Relative Density and Absorption of Fine Aggregates
	C 88	Soundness of Aggregates by use of Magnesium Sulphate
	D 6928	Degradation Test or Resistance of Coarse Aggregate to Degradation by Abrasion in the Micro-Deval Apparatus
SS 202 Appendix 1		Fracture Count on Coarse Aggregate
	C 566	Moisture Content of Aggregate by Drying
	D 4318	Liquid Plastic Limit Determination

SECTION 531

ASPHALT SURFACE TREATMENTS

elongated or flaky pieces such as may cause the height constant of the particles to be less than 0.6 (refer to BC Highways Paving Branch Manual of Test Procedures BCH-VI). It shall be substantially free from loosely bonded aggregations, clay lumps or other objectionable matter and shall not, in the Ministry Representative's opinion, be markedly hydrophilic in character.

531.15.02 Test Requirements - For the purpose of testing, the mineral cover aggregate shall be considered to be divided into coarse and fine (sand) fractions. Fine aggregates shall consist of all material passing through a 4.75 mm standard sieve, unless some other boundary shall be specifically described under the respective Method of Test. The mineral cover aggregate, when tested by the methods listed in SS 531.14, shall meet the following criteria:

- a) **Clay Lumps** - Coarse aggregate shall not contain more than 0.5% by mass of clay lumps or other aggregation of fine material.
- b) **Absorption** - maximum 1.0% by mass for coarse aggregate; maximum 1.5% by mass for fine aggregate.
- c) **Soundness** - When tested for soundness by ASTM C 88, the aggregate shall not show a weighted loss for five cycles in excess of 12% when Magnesium Sulphate is used (or have a satisfactory record of service).
- d) **Degradation** - No individual test shall have a more than 20 when tested in accordance with ASTM D 6928

531.17 Graded Aggregate Seal - Requirements

531.17.01 Gradation - Gradations shall meet the limit stated in Table 531-E for each Class of graded aggregate seal.

- a) **Fracture** - When tested according to SS 202, Appendix 1 fractured faces, the minimum % by mass on course aggregate shall be as follows:
 - Classes A & B = 70%
 - Classes C, D, & E = 85%

b) **Variation Limits** - Once the grading curve is established within the above limits, the maximum permissible variation of the mean of any five consecutive tests from the grading curve shall be within the tolerance specified in Table 531-F

These tolerances do not waive the requirement that the running average of five consecutive tests must be maintained at all times inside the limits specified in SS 531.17.01. Should the Contractor not be able to

maintain the grading within the variation limits specified above they shall be required to construct a second stockpile. This does not alleviate the Contractor from consistently maintaining the grading curve within the tolerances indicated in the gradation curves.

c) General Usage

- Class A & B - Double seals on gravel highways
- Class B - Low traffic paved roads
- Class C & D - Major Highway
- Class E - Residential areas & Second seals

TABLE 531-E GRADATION LIMITS FOR GRADED AGGREGATE SEAL

Sieve size (mm)	CLASS				
	Mass Percent Passing				
	A	B	C	D	E
19	100	-	-	-	-
16	-	100	100	-	-
13.2	60 - 90	60 - 90	-	100	-
9.5	40 - 80	35 - 75	30 - 70	30 - 80	100
4.75	20 - 60	15 - 50	25 - 45	25 - 45	0 - 30
0.600	0 - 25	0 - 15	5 - 20	5 - 20	0 - 10
0.075	0 - 7	0 - 5	0 - 3	0 - 3	0 - 2

TABLE 531-F VARIATION LIMITS

Sieve Size (mm)	Maximum Permissible Tolerance % Passing by Mass (Test B.C.H. I-1 & I-2)
4.75 to 19.0	± 4.5
1.18 and 2.36	± 4.0
0.600	± 3.5
0.300	± 2.5
0.150	± 1.5
0.075	± 1.0

531.17.02 Coarse Aggregate

- a) will be defined as all material retained on the 4.75 mm sieve.

SECTION 531

ASPHALT SURFACE TREATMENTS

b) shall consist of crushed stone or gravel, or a combination thereof; or materials naturally occurring in a fractured condition; or materials naturally occurring of highly angular nature or rough texture with a maximum result of 20 when tested in accordance with ASTM D 6928.

c) shall be free from coating of clay, silt or other deleterious material and shall meet the applicable tests requirements of SS 531.14 and SS 531.15.

531.17.03 Fine Aggregate

a) will be defined as all materials passing the 4.75 mm sieve and shall meet the applicable test requirements of SS 531.14 and SS 531.15.

b) shall be clean, hard, durable, moderately sharp, and free from coatings of clay, silt or other deleterious material and shall contain no clay balls or other aggregations of fine material.

531.17.04 Mineral Filler and Mineral Dust

a) Mineral filler shall consist of all mineral matter passing the 0.600 mm sieve and the mineral dust shall consist of all mineral matter passing the 0.075 mm sieve.

b) Mineral filler and mineral dust shall be free from organic matter.

c) Mineral filler shall be non-plastic when tested in accordance with ASTM D 4318.

531.18 Presealing Sand - Sand required for use as a fine aggregate in connection with presealing operations conducted under SS 531.36 shall meet the physical requirements of SS 531.15, but unless otherwise specified by the Ministry Representative, shall have a grading as specified in Table 531-G.

TABLE 531-G PHYSICAL REQUIREMENTS FOR SAND IN A FINE AGGREGATE

SIEVE SIZE (mm)	PERCENTAGE PASSING
4.75	100
2.36	80 - 100
1.18	60 - 90
0.300	25 - 70
0.150	10 - 40
0.075	2 - 12

All aggregate passing the 0.425 mm sieve shall be non-plastic.

EQUIPMENT

531.21 General

531.21.01 When submitting the bid for work under the Contract, the Contractor shall, at the same time, submit a list of equipment available and ready for use on the Project.

531.21.02 Before any work is permitted to commence, the Contractor's equipment and plant will be carefully inspected and should any of it fail to meet the required standards, work will not be permitted to commence until such deficiency is corrected.

531.21.03 Once the Contractor's bid has been accepted, provision of all equipment listed shall become an essential part of the contract and no equipment or plant may be released from the Project work for use elsewhere until completion, except by the express written permission of the Ministry Representative.

531.21.04 The Ministry inspectors shall have access at all times to any plant, equipment or machinery to be used on the Project in order to check calibration, control or operating adjustments. Where adjustment appears necessary, it shall be done by a competent operator or mechanic or instrument repair technician, as required.

531.21.05 Plant, machinery and equipment specified hereafter shall represent a minimum requirement for the type of machine described and does not represent a comprehensive list of equipment to be supplied by the Contractor who shall supply whatever plant and equipment may be necessary to the proper and efficient completion of

531.21.06 All plant and equipment shall be under the control of experienced and skilled operators.

531.22 Pressure Distributor - The pressure distributor used for applying asphalt materials shall consist of a fully insulated tank with a minimum capacity of 5000 ℓ, permanently and rigidly mounted on a truck or fifth wheel trailer provided with pneumatic tires and propelled by a power unit capable of maintaining a constant and uniform speed.

The pressure distributor, to be acceptable, shall be provided with at least the following equipment:

- a) A quick opening gate in the dome.

SECTION 531

ASPHALT SURFACE TREATMENTS

- b) A dipstick calibrated in 20 mm increments and a calibration chart showing the volume for each 20 mm of depth, or provide the manufacturer dipstick and chart. Readily visible external depth gauge indicating the quantity of asphalt in the tank to the nearest 50 ℓ.
- c) A means of heating the asphalt material uniformly to any temperature up to 175°C and maintaining the contents constantly at any selected temperature without any local overheating.
- d) A heavy duty, industrial-type thermometer and a remote reading dial thermometer.
- e) Rear-mounted spray bars and nozzles set parallel to the surface to be sprayed and capable of vertical and lateral adjustment. The spray bars shall be capable of adjustment to provide a uniformly sprayed surface from a minimum of 0.6 m to at least 4 m width.

The spray bars shall be capable of producing up to triple coverage at one pass. The feed to the spray bars must be arranged so that there is a constant circulation of hot asphalt material to the bars to ensure a uniform viscosity and constant pressure of the liquid asphalt at each nozzle both before and during spraying operations.
- f) The feed manifolds to the spray bars shall be provided with positive filtration to prevent clogging of bars and nozzles.
- g) Rotary adjustable spray bar nozzles shall be of the same type, correct size and manufacture; and set to produce uniformly fan-shaped sprays without atomization. Nozzles shall be inspected daily and any nozzle having nicked or damaged edges shall be replaced.
- h) Spray nozzles shall be provided with valves capable of instant full opening and positive cut-off.
- i) A connection to a circulating pressure manifold to which a hose may be attached for a single nozzle hand-operated outlet.
- j) A pressure pump capable of applying the asphalt material at a minimum rate of 180 ℓ per minute, per metre of spray bar.
- k) A pressure gauge accurate to within 15 kPa and a metre calibrated in litres per minute, shall be readily visible.

- l) A fifth wheel tachometer, calibrated in metres per minute and readily visible to the operator of the distributor.
- m) Vehicle spring "tie-downs" to prevent the change in height of the spray bars due to the reduction of the asphalt load during spraying.
- n) Electronic distance measuring device, with print out connected to the transmission, that is capable of measuring each spray length and the total length sprayed during the day.

531.23 Mechanical Spreader - Cover aggregate shall be spread by means of an efficient, self-propelled spreader mounted on pneumatic tires and capable of continuously and uniformly spreading closely regulated quantities of crushed aggregates at the application rates selected. The loading hopper shall be of such a capacity as to ensure continuous operation between dumps of aggregate. Aggregate shall be transferred from the loading hopper to the front spreading device in such a manner as to ensure a uniform flow and prevent segregation of particles.

The spreading mechanism shall be so designed as to distribute and spread aggregate across the selected width without segregation. Aggregate shall be applied to the freshly sprayed surface by use of a screen so that the largest particles are first placed on the road with the smaller fractions falling on top. The approved screen is to be mounted beneath the discharge openings of the spreader mechanism in such a manner that the angle of the screen relative to the road surface can be easily and quickly changed.

Suitable provision shall be made to prevent aggregate from rolling on the freshly sprayed surface. The cover aggregate shall be applied ahead of the spreader wheels, with sharply defined, straight edges and without any lateral movement of the aggregate after initial application.

A walkway with protective railings, conforming to the applicable W.C.B. Regulations, shall be provided at the front of the spreader so that the hopper operator has safe access to the individual gate control levers.

The spreader shall be designed to apply aggregate at any application width between 2 m and 4.12 m. (Note: a 4.26 m hopper is required.)

531.24 Rollers - Self-propelled pneumatic tired rollers (mass range from 13 600 kg to 19 000 kg) shall be used on the work. The rollers shall have a minimum effective rolling width of 1.83 m. The rollers shall be equipped with smooth, wide-tread compaction tires of equal size and diameter. The wheels of the roller shall be spaced so that one pass of the roller shall accomplish one complete

coverage equal to the rolling width of the machine. There shall be a minimum overlap of 6 mm of the tracking wheels of the roller. The wheels shall be so mounted as to oscillate in pairs. The roller shall be provided with ample ballast space and be so constructed that the specified wheel load can be uniformly applied to all the wheels, to provide similar contact pressure under all wheels when rolling on a level pavement.

The tires shall have a minimum of 16 ply and their inflation pressure shall not normally exceed the specified pressure by more than 35 kPa and shall at no time be less than specified. Inflation pressure of all of the tires shall be controlled from a central location while the machine is in motion and capable of varying the tire pressure from 206 kPa to 827 kPa. Rollers shall be ballasted and operated to the manufacturers recommended specifications.

The Ministry Representative may approve the use of compactors equal to but differing from the above requirements provided the Ministry Representative is satisfied that equally effective compaction will be obtained by use of the alternative equipment.

The Ministry Representative may approve the use of rubber-covered, vibrating drum rollers (minimum width of 1.52 m and mass of 3000 kg) or tandem steel wheel rollers in the static mode provided the drum or drums can contact the road surface over the entire width of the drums (no bridging). On shoulder seals, the use of pulled wobbly wheel rollers may be used at the discretion of the Ministry Representative. They also may be used on graded aggregate seal on gravel surfaces, where the road is wide enough to permit units to turn without damage to the road surface, sealed or otherwise.

All rollers shall be provided with equipment for spraying water continuously on all tires or wheels, while rolling is in progress, and also be provided with such means as may be required to keep the tires clean and free of adhering asphaltic binder.

531.25 Power Brooms - Brooming work shall be carried out using rotary power brooms mounted on self-propelled, pneumatic tired tractor units. The brooms shall be capable of vertical and horizontal angular adjustment and must be provided with equipment for spraying water, as required, on the surface to be broomed while the equipment is in operation. The brooms shall have sufficient power and brushing capacity to completely clean the surface of the standard lane to be treated or which has been treated within three coverages.

This Subsection is to be read in conjunction with SS 145.19 and SS 165.

531.26 Blade Graders - Self-propelled blade graders mounted on pneumatic tires shall be of approved modern type, either four wheel drive or tandem type, having sufficient capacity to efficiently perform all work that may be required on the contract.

531.27 Water Truck - Water trucks shall have a minimum capacity of 9000 ℓ. Water shall be applied from a distributor of the pressure type, equipped with a spray bar mounting nozzles similar to those used on asphalt distributors and capable of applying the water accurately and uniformly. Splash plate type of distributors or those equipped with spray bars that eject fine streams of water will not be permitted.

The distributor must be provided with a satisfactory means for accurately measuring the quantity of water sprayed. If the Ministry Representative so requires, measuring equipment shall be calibrated under the Ministry Representative's inspection. The Contractor shall make all necessary arrangements for obtaining water at the Contractor's own expense. In addition, the water truck shall be equipped so that it may be used as a flush truck with front-mounted, adjustable spray nozzles that produce a fan-shaped spray in the horizontal mode and can be adjusted in vertical or horizontal direction (ball-mounted). The delivery of water should be variable to single or multiple nozzles so that the desired flushing can be achieved. The water truck shall be equipped with a loading pump capable of pumping 1360 ℓ or more of water per minute.

The spraying and flushing controls must be in the cab and accessible to the driver while the unit is in motion. The minimum spray bar width will be 2.40 m. Gravity single jet or drip bar equipment unit will not be permitted.

531.28 Sign Truck - Truck(s) of sufficient capacity to store and transport all necessary signs, stands, barriers, flashing lights, batteries, flood lights, generators, high-level warning devices, project signs, etc., is required.

531.29 Tanks, Mobile Asphalt Heating, & Storage - Insulated liquid asphalt storage tanks should meet the following minimum criteria:

- a) A positive high-low heating system, 10° to 200°C, with a hot oil/steam circulation system.
- b) Automated heating and control system with safety shutdown.
- c) Intake/Outlet, two, each with screens installed.
- d) Positive locking valve on discharge line.

SECTION 531

ASPHALT SURFACE TREATMENTS

- e) Sampling valve or spigot.
- f) Pyrometer; Multi point 20° - 200°C.
- g) Direct reading levelometer.
- h) Manholes, at each end, with ladders.
- i) Tank(s) with sufficient capacity to hold one day's production requirements.

CONSTRUCTION

531.31 Temperature and Weather - Asphalt binder and aggregate shall be applied only during the hours of daylight when the shade air temperature is at least 10°C for graded aggregate seals and is rising; and when the surface of the road is dry and at a minimum temperature of 20°C and rising. Operations shall cease when the temperature falls below 20°C for chip seals and 15°C for graded aggregate seals. No application shall take place when, in the opinion of the Ministry Representative, the weather or roadbed conditions are unfavourable, i.e., weather is misty or rainy, precipitation is predicted for the construction area within 12 hours or the atmospheric temperature at the construction area of less than 12°C is predicted within 24 hours. No chip seal shall be effected before June 1 or after August 15.

531.32 Traffic Control - Traffic control shall meet the requirements of SS 194 and the following:

531.32.01 Signs and Barriers - The Contractor shall provide all warning and instructional signs, barriers, lights, electronic communicating devices and flagpersons required to properly and safely control all traffic around or through the work in accordance with SS 194, and as may be specially required below.

531.32.02 Detours - Where conditions indicate that traffic may be detoured, the Contractor shall arrange to close off the section of road to be sealed and erect detour and route signs. After the completion of the sealing operations traffic shall not be allowed onto the closed sections after the completion of the sealing operations, for the periods specified in SS 531.32.04, SS 531.36.06 and SS 531.37.04, unless otherwise directed by the Ministry Representative.

531.32.03 Shoulder Detours - Where shoulders are wide and firm enough to accommodate traffic that cannot be detoured along an alternative route, the Ministry Representative may direct that traffic be detoured onto the shoulder. If required, and approved by the Ministry Representative, the shoulder shall be made up, rolled and graded on a force account basis. A designated liquid

asphalt shall be sprayed from the edge of the road to the edge of the shoulder, as required, and allowed to cure before traffic is detoured off the road to be sealed and onto the shoulders.

The Contractor shall provide sufficient pilot cars and barriers to maintain traffic movement at a maximum speed of 40 km/h solely on the shoulders, during the course of work. Once a section has been sealed, traffic will be regulated as indicated in SS 531.32.04.

531.32.04 Traffic Through Work - Where it is not possible to detour traffic, sealing work shall normally be carried out in lane widths and traffic shall be regulated by pilot cars on the opposite traffic lane to that on which construction is in progress. Traffic travelling on the old road surface may be permitted to travel up to a maximum speed of 50 km/h consistent with safety requirements. Traffic shall only be allowed to travel on the newly-sealed lane under control of a pilot car or cars which shall enforce a 20 km/h speed limit up to 4 hours and a 30 km/h speed limit for a period of up to 24 hours, as determined by the Ministry Representative, after completion of the sealing operations; except in the case of pre-seal construction when the period of control shall be up to 4 hours after completion of the pre-sealing operation.

In the event of prolonged inclement weather, traffic control will be maintained as long as the Ministry Representative deems necessary to protect newly laid surface seals.

531.32.05 Pilot Cars - Sufficient pilot cars shall be provided so that the delay to traffic shall be no greater than 20 minutes. They shall be equipped in accordance with SS 194.

531.32.06 Communications - The flagpeople, pilot car or cars, sign truck, spreader and supervisor's vehicle shall have an effective electronic means of communication so that instructions and information can be quickly and accurately relayed over the total length of the control area.

531.32.07 Flood Lights - During periods when headlights must be used, including during daytime periods of poor visibility and high dust condition, two self-contained floodlights shall be used to illuminate each of the flagging stations. These floodlights shall be of at least 1000 watts and be complete with reflector, lens and adjustable stand at least 2.15 m high. The light, reflector and lens must be mounted so that they are capable of both vertical and horizontal adjustment. The stands are to be sufficiently sturdy so that they can withstand a 30 km/h wind without the use of ballast. The generators shall have a full capacity sufficient to enable them to run one shift under full load.

SECTION 531

ASPHALT SURFACE TREATMENTS

531.32.08 Flag Personnel - Flag personnel shall be equipped in accordance with SS 194 and provided as required to safely control and conduct traffic through the job.

531.33 Preparation of Roadway - The patching and levelling of the pavement to be sealed may be part of a sealcoating contract or may be effected by others.

531.34 Sweeping - Sweeping shall meet the requirements of SS 145, SS 165, and SS 531.27 regarding equipment for watering and the following:

- Immediately prior to the commencement of the sealing operations, all loose aggregates, dust, dirt, caked clay or foreign materials shall be removed from the width of the surface to be treated by brushing with power brooms supplemented by hand push brooms, shovels or the use of a power grader, and where necessary by flushing.
- Particular care shall be taken to thoroughly clean to outside edges of the strips to be treated and to ensure that the sweepings are not so deposited on the shoulder as to permit subsequent contamination of the treated surface.

531.35 Patching - In order to avoid delays to the Contractor, any patching not done, and in the opinion of the Ministry Representative required before sealing operations begin, may be done by the Contractor as directed by the Ministry Representative with materials supplied by the Ministry and paid for under an Order for Extra Work.

531.36 Pre-Seal Treatment

531.36.01 Description - Wherever the pavement is in a worn, open, dry or porous condition, or on gravel surfaces which, in the opinion of the Ministry Representative, would result in high absorption of the asphalt binder, the surface shall be pre-sealed. All pre-sealing work on a Contract shall, unless otherwise ordered by the Ministry Representative, be fully completed prior to the commencement of seal coat work.

531.36.02 Application of Asphalt Pre-Seal - After the surface has been prepared in accordance with SS 531.33 and SS 531.34, a selected asphalt binder shall be sprayed, at such application rates as directed, so that just sufficient asphalt material shall be applied to the most absorptive sections of the mat, avoiding an excess elsewhere. The asphalt binder shall be applied at the temperature at which the Saybolt-Furol Viscosity of the material is in the range of 50 - 75 seconds.

531.36.03 Application of Sand Cover

a) Application of sand in sufficient quantity to completely blot up all excess unabsorbed asphalt material shall follow within five minutes or as may be directed by the Ministry Representative.

b) At the time of spreading, the sand shall not contain more than 5% moisture by mass.

531.36.04 Rolling - Rolling shall commence immediately after the application of cover sand and shall be completed within 15 minutes. Sufficient pneumatic tired rollers shall be used to ensure that the entire surface of the treated road receives complete coverage within the specified time, at a rolling speed not in excess of 8 km/h.

531.36.05 Bleeding - Bleeding spots or areas shall receive a further application of sand blotter and be re-rolled. This process shall be repeated until no further bleeding occurs.

531.36.06 Traffic - No traffic shall be permitted on pre-sealed sections for up to four hours or as the Ministry Representative may direct.

531.36.07 Curing Time - No seal coating work shall be carried out on the pre-sealed surface until 24 hours after completion of the pre-seal or as the Ministry Representative may direct.

531.36.08 Sweeping - Prior to commencement of the main seal-coat treatment all loose, unbonded sand shall be swept from the pre-sealed surface in accordance with SS 531.34.

531.37 Single Pass Surface Treatment

531.37.01 Application of Asphalt Material - The selected asphalt material shall be uniformly sprayed on the properly prepared surface at a rate of 0.5 to 2.75 ℓ/m^2 , or as may be directed, and at such temperature as shall cause the Saybolt Furol Viscosity of the material to be within 50 - 75 seconds.

Wherever it is possible to detour traffic, the surface may be sprayed full width at one pass of the distributor. Two spreaders must be used.

Normally, where it is not possible to detour traffic only one half of the roadway shall be sprayed at one time, permitting one-way controlled traffic on the other half. In no case shall a longitudinal joint be so placed that it is in a wheel path, the exception being when a double graded seal is being applied.

In order to ensure a uniform distribution of asphalt material and avoid the formation of a lap or ridge at the transverse junction of two successive applications,

SECTION 531

ASPHALT SURFACE TREATMENTS

building paper shall be spread over the treated surface for a sufficient length back so that the spray jets are operating properly (fully open) when the uncovered surface is reached. The building paper shall then be removed and disposed of prior to the application of aggregate. (Refer to SS 165.)

There shall be a maximum 100 mm overlap of sprayed material at the longitudinal joint between sprayed lanes.

The spray shall be cut off before the distributor tank has been completely emptied to ensure that a full application of asphalt material is made up to the point of cut off.

Pressure hand sprays shall be used to properly treat small patches or inaccessible places that have been missed by the distributor. Care shall be taken and building paper shall be used, if necessary, to ensure against staining any curbs, guardrails or faces of any improvements near the work.

The progress of the application of the asphalt material shall be governed by the weather, the curing rate of the asphalt and the rate at which the cover aggregate is applied and rolled. No traffic shall be permitted on the uncovered asphalt material. The Contractor shall organize work so that seal-coating can normally be completed to the full width of the road surface each day.

531.37.02 Application of Cover Aggregate

a) Application - The uniform application of the specified cover aggregate, at the spread rate set by the Ministry Representative, shall immediately follow the application of the asphalt material, before the emulsion breaks or within 2 minutes if a cutback asphalt is sprayed. An approved screen shall be used to place the larger chips or particles of aggregate onto the sprayed asphalt first so that maximum embedment of the larger material is obtained. Any segregation shall be corrected immediately.

b) Moisture Content

Graded Seal Aggregates - At the time of spreading, the moisture content of the aggregates shall be such that the material will flow freely in the hopper without segregation and/or a build up of material on the screen.

c) Prior to and during the rolling operation, any non-uniformity in the distribution of the cover aggregate shall be corrected by spreading additional aggregate and/or by light raking or hand brooming over such sections of the road as the Ministry Representative directs.

TABLE 531-I MAXIMUM MASS PERCENTAGE FOR MOISTURE CONTENT OF COVER AGGREGATE

AGGREGATE TYPES	MAXIMUM ALLOWABLE MOISTURE CONTENT FOR LIQUID CUT BACK AND ASPHALT EMULSIONS
Fine Cover Sand	5%
Coarse Cover Sand	4%
Small Cover Aggregate	3%
Medium Cover Aggregate	2%
Large Cover Aggregate	1%

531.37.03 Rolling - Immediately after the aggregate has been uniformly spread, the road surface shall be rolled sufficiently to embed the aggregate into the asphalt material to the satisfaction of the Ministry Representative.

Sufficient pneumatic tired rollers shall be used to ensure that the entire surface of the aggregate receives at least five complete coverages within 15 minutes of the application of asphalt material; or when asphalt emulsion is used, five complete coverages shall be completed before the emulsion starts to break.

The speed of the rollers shall be such that the suction of the tires shall not displace the aggregate from the road surface or a maximum of 8 km/h, whichever is less.

The completed surface shall present a uniform appearance. Any segregation or non-uniformity in the distribution of the aggregate shall be corrected by spreading additional material over the area and re-rolling with five coverages of the rollers.

531.37.04 Protection of the Surface

a) No traffic shall be permitted on the sealed surface until after the rolling has been completed and when the Ministry Representative is satisfied that the applied aggregate will not be picked up or be displaced under traffic. Generally, traffic shall not be permitted on the sealed roadway until at least 2 hours after the rolling is completed. If traffic must be passed over a sealed surface before 2 hours have passed then they will be kept to a speed of 20 km/h or less. After 2 hours, then the speed may be increased to 30 km/h up to 4 hours and not more than 50 km/h for 24 hours or until the surface has been swept. The curing period shall be increased if so directed by the Ministry Representative.

b) From the completion of rubber tired rolling on any section of sealed surface and for a further continuous

SECTION 531

ASPHALT SURFACE TREATMENTS

period of 3 days or more including weekends and public holidays, the Contractor shall have a vehicle(s) and maintenance crew (a minimum of three employees) immediately available to arrest any tendency of the asphalt binder to bleed through the surface of the cover aggregate and to prevent pickup and blackening of the surface by the action of traffic. All bleeding spots shall be blotted with a sufficient quantity of blinding sand necessary to correct the defect and in such a manner as the Ministry Representative shall direct. No payment will be made for the supplying and placing of the sand.

c) Blinding Sand - In the event of rain, traffic will be kept off a newly sealed surface until sand, provided by the Contractor, has been applied in sufficient quantity to protect the surface of the road from damage. Sanding will continue as long as necessary to protect the freshly laid seal.

Payment for the supply and application of this sand will be by Order for Extra Work.

531.37.05 Removal of Loose Aggregate - To be read in conjunction with SS 145 and SS 165.

a) The Contractor shall, when directed by the Ministry Representative, sweep off all surplus aggregate and spread it neatly along the gravel shoulders. Sweeping of the road surface will normally be completed 48 hours for graded aggregate seals. This operation shall be done while the road surface is cool and care should be exercised not to disturb the aggregate that has been retained in the asphalt. In the event that cover aggregate is being disturbed, brooming will cease until curing is complete and the cover aggregate is firmly held in place. Water shall be used in sufficient quantity to reduce dust hazard and to meet pollution control requirements.

b) Alongside barriers and curbs and where catch basins or drainage outlets are encountered, the Contractor shall pick up and dispose of the surplus aggregate, including any pertinent cleaning of catch basins, behind the barriers or curbs or within the right-of-way, in any manner the Contractor elects, subject to the approval of the Ministry Representative.

531.38 Double Pass Surface Treatment

531.38.01 Preparation of Existing Surface - Existing surface preparation shall be performed in accordance with SS 531.33 through SS 531.36 as applicable and as detailed in the Special Provisions.

531.38.02 Surface Treatment - First Pass - The first pass of the surface treatment shall be performed in accordance with SS 531.37.01 and SS 531.37.02, using the graded seal cover aggregate specified in the Special Provisions. Rolling, Surface Protection and Removal of Loose Aggregate shall conform to SS 531.37.03 through SS 531.37.05.

531.38.03 Surface Treatment - Second Pass - The second pass of the surface treatment shall commence not less than 24 hours after completion of the first pass, subject to acceptable weather conditions as detailed in SS 531.31, and as the Ministry Representative may direct. Asphalt material shall be applied in accordance with SS 531.37.01, followed by an application of graded seal aggregate as specified in the Special Provisions and detailed in SS 531.37.02, and rolling, surface protection and removal of loose aggregate per SS 531.37.03 through SS 531.37.05.

MEASUREMENT

531.81 Surface Treatment - Surface treatment will be measured by the SQUARE METRE.

531.82 Flag Persons - Flag persons will be measured by the HOUR.

531.83 Pilot Cars - Pilot cars will be measured by the HOUR.

531.84 Asphalt Binder - Asphalt binder (100 000 ℓ or less) will be measured by the LITRE.

Asphalt binder (greater than 100 000 ℓ) will be supplied by the Ministry f.o.b. the Contractor's tanks.

531.85 Aggregates - Where the Special Provisions requires the Contractor to supply the aggregate, the aggregate will be measured by the CUBIC METRE in stockpile. The volume will be determined by cross-sectioning and end area volume calculations.

531.86 Stockpile Bases - No measurement will be made for work and materials required for the preparation of stockpile bases, as directed by the Ministry Representative.

PAYMENT

531.91 Surface Treatment - Payment for SURFACE TREATMENT will be at the Contract Unit Price per square metre. The Unit Price shall cover everything done and supplied including ordering, receiving, storing and heating of asphalt materials, traffic control equipment, and all equipment and labour required to complete the work.

531.92 Flag Persons - Payment for FLAG PERSONS

SECTION 531

will be at the Contract Unit Price per hour.

531.93 Pilot Cars - Payment for PILOT CARS will be at the Contract Unit Price per hour.

531.94 Asphalt Binder - Payment for ASPHALT BINDER will be at the Contract Unit Price per litre actually sprayed.

531.95 Aggregates - Payment for AGGREGATE will be

ASPHALT SURFACE TREATMENTS

at the Contract Unit Price per cubic metre in stockpile.

No additional payment will be made for washing when needed in order to meet gradation requirements.

531.96 Stockpile Bases - All work and materials required for the PREPARATION OF STOCKPILE BASES, as directed by the Ministry Representative, will be paid for, on an Order for Extra Work basis from the Provisional Sum included in the Schedule of Approximate Quantities and Unit Prices.

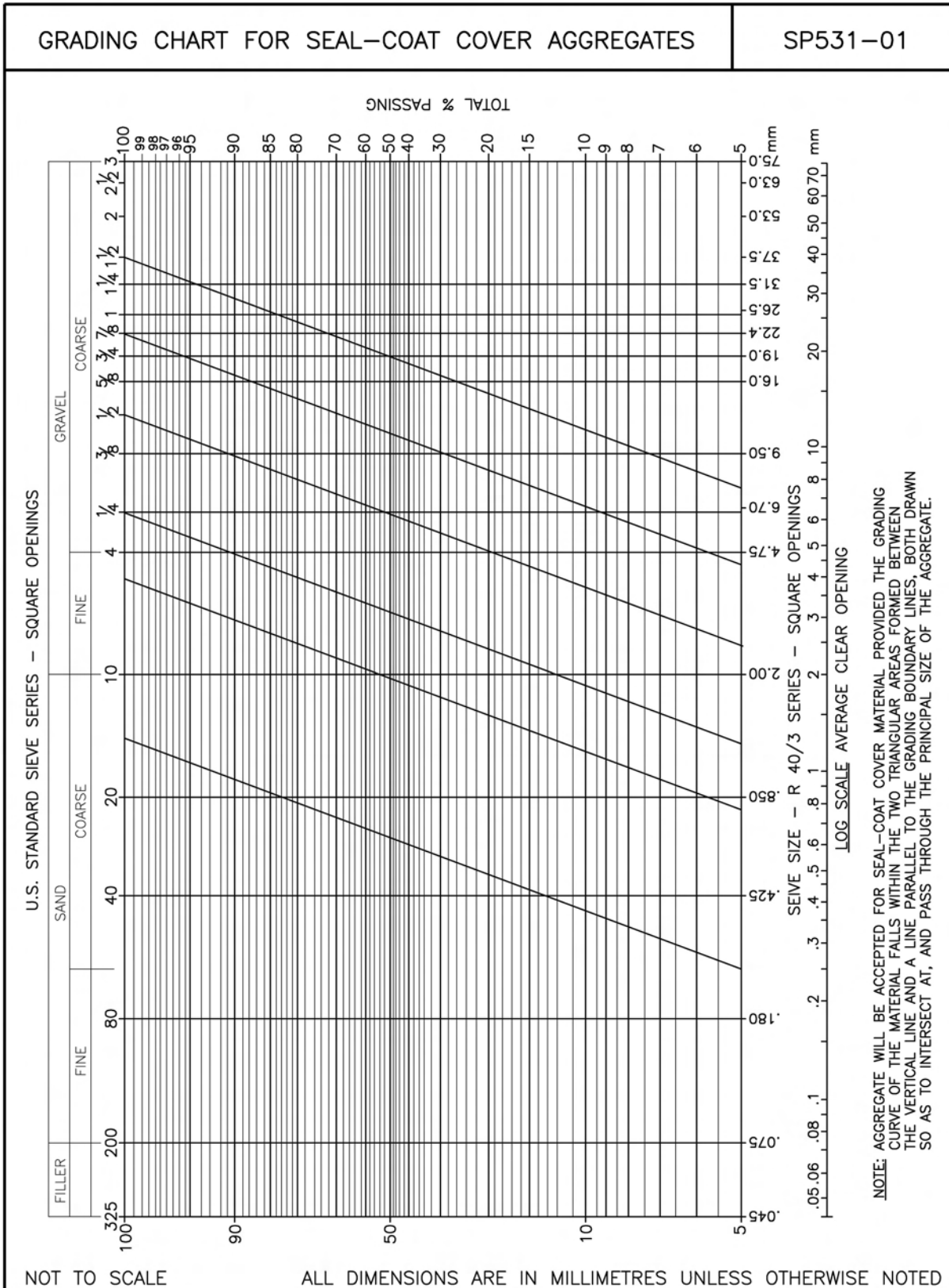

NOTE: AGGREGATE WILL BE ACCEPTED FOR SEAL-COAT COVER MATERIAL PROVIDED THE GRADING CURVE OF THE MATERIAL FALLS WITHIN THE TWO TRIANGULAR AREAS FORMED BETWEEN THE VERTICAL LINE AND A LINE PARALLEL TO THE GRADING BOUNDARY LINES, BOTH DRAWN SO AS TO INTERSECT AT, AND PASS THROUGH THE PRINCIPAL SIZE OF THE AGGREGATE.

THIS PAGE IS LEFT INTENTIONALLY BLANK

SECTION 536

PAVEMENT CRACK SEALING

DESCRIPTION

536.01 Scope - This work consists of restoring the asphalt concrete pavement surface to a less permeable condition. The work includes routing when necessary, cleaning and filling the crack with sealant, and dusting or sanding.

536.02 Purpose - The purpose of crack sealing shall be to prevent moisture from penetrating into the road base through surface cracks and to extend pavement life. This shall be carried out by effectively sealing the cracked surface with a highly rubberized and elasticized or high float asphalt sealant.

MATERIALS

536.11 Asphaltic - The rubberized and elasticized asphalt sealant products shall meet the requirements listed in Table 536-A.

It shall be noted that ASTM D 3405 requirements are not mandatory in the Lower Mainland, Vancouver Island or the Sunshine Coast.

As specified in the Special Provisions the Contractor shall use a Rubberized or High Float Emulsified Asphalt HF150S or equivalent.

TABLE 536-A REQUIREMENTS

ASTM Test	DESCRIPTION
D 3405	Specification for joint sealants, hot poured for concrete and asphalt pavements
D 1190	Specification for concrete joint sealer, hot poured elastic type

536.12 Sand - On pavements that require the use of High Float Emulsified Asphalt, the Contractor shall supply a "blinding sand." The sand, when tested according to ASTM C 117, shall meet the gradation requirements shown in Table 536-B and shall be approved by the Ministry Representative.

536.13 Dust Cover - Pavements that are sealed with rubberized or elasticized sealant shall receive a dust coating with a material such as Portland Cement, talc, lime or the equivalent material approved by the Ministry Representative.

EQUIPMENT

536.21 Router - The Contractor shall provide a vertical router capable of routing asphaltic pavements to a depth of 25 mm and a width of 16 mm. It shall be capable of a minimum production of 200 metres per hour, even when following meandering cracks without unnecessary pavement cutting.

TABLE 536-B GRADATION REQUIREMENTS

Sieve (mm)	% Passing
12.5	100
9.5	80 - 100
4.75	50 - 95
2.36	30 - 80
0.600	10 - 50
0.300	0 - 25
0.075	0 - 6

536.22 Cleaner - The cleaner unit shall be a hot compressed air fed propane fired device capable of cleaning, heating and drying routed cracks with not less than 1.7 m³/min. of compressed air at 690 kPa. It shall have valving/hoses and fittings for the mixture of liquid propane gas and compressed air. The hot air exhaust shall not exceed 315°C.

536.23 Melter - The melting kettle shall be of the double boiler type supplying indirect heating so as to slowly heat the asphaltic material with heat transfer oil. It shall have built in calibrated thermometers for both transfer oil and the sealing compound. The heating of the sealant shall be efficient and thermostatically controlled so as not to exceed the manufacturer's maximum safe heating temperature and shall be such as to maintain a constant temperature once the sealant is heated. The melter shall be capable of constantly agitating the asphaltic material as it is being heated and shall have a pump circulating the sealant from the bottom to the top of the kettle.

The melter must comply with the Gas Safety Act Regulations and Codes and any other applicable acts and regulations.

536.24 Filler Tools - Crack filler devices and strike off tools must be such that successful forming of the bead of sealant over the prepared crack is as specified in this Specification.

CONSTRUCTION

536.31 General - Crack sealing shall only be performed when the pavement surfaces are dry, and the crack and road base are dry or nearly dry (no visible moisture), and the temperature is steady at 10°C or rising.

A random sample of virgin sealant shall be selected from each lot for testing purposes by the Ministry Representative.

Cracks up to 16 mm in width shall be widened by using a router to form a sealant reservoir 16 mm in width and from

SECTION 536

PAVEMENT CRACK SEALING

19 to 25 mm in depth. All routing shall be performed keeping the crack centreline within ± 8 mm of the centre of the rout and shall be cleaned with a hot compressed air lance. Material removed from the cracks shall be disposed of as approved by the Ministry Representative.

The routing speed shall be such that the pavement is carefully cut, not broken or torn out, and the sides of the rout are smooth and uniform. The surface of the pavement and routed crack shall be cleaned of all dust and routing debris.

Routing should not be carried out on pavements that are of such an age that the pavement fractures or spalls occur along the edge of the freshly routed crack. Normally pavement fractures or spalls should not occur unless pavements are in excess of 10 years old. The decision to forgo routing shall be made by the Ministry Representative.

The crack shall be filled with sealant from the bottom to the surface level in such a manner that the sealant does not bridge entrapped air pockets. Material shall be placed to overfill the crack. It will then be struck off to leave a uniform amount of sealant directly over the crack, with the edges of the spread evenly feathered to overlap on the pavement surface from a minimum of 25 mm to a maximum of 40 mm on each side of the crack. The sealant overband shall not be so thick that it can be removed during snow plowing or produce a noticeable bump when traversed by traffic.

Any damage done to the sealant by stones or any other deleterious material being embedded in the sealing compound shall be repaired by the Contractor.

The Contractor shall ensure that traffic is kept off the sealed cracks until such time as the sealant has properly set up and will not be damaged or pulled out by the passage of traffic.

536.32 Rubberized and Elasticized Asphalt Sealants -

These shall be used on pavements that are less than 10 years old and where the majority of cracks are less than 25 mm in width.

The sealant shall be applied to cracks that have been routed to a uniform depth and width.

Cracks having a width greater than 16 mm need not be routed but shall be cleaned to a minimum depth of 25 mm.

Within two minutes of the completion of the cleaning operation the crack shall be filled with sealant from a

melter using a connecting wand or manual applicator (pouring cone) which ensures minimum pour application temperatures for the product are maintained.

Upon completion of the pouring the sealant shall be dusted to prevent the asphalt from tracking. Excess dusting material shall be removed.

536.33 High Float Emulsified Asphalt - High Float Emulsified Asphalt shall be used on pavement where there are depressions or lipping at the cracks, or the majority of cracks are over 25 mm in width.

The cracks shall be cleaned as close to the actual depth as possible and the removed material shall be disposed of as approved by the Ministry Representative. Immediately after cleaning, they shall be filled with sealant from a distributor truck or melter. The distributor truck or melter shall have an efficient means of heating the sealant to any temperature up to 100°C and maintaining it constantly at the manufacturer's prescribed temperature without overheating.

Upon completion of the sealing of the crack, the sealant shall be sanded to prevent the asphalt from tracking. Excess sand shall be removed and disposed of by the Contractor as approved by the Ministry Representative.

536.34 Warranty - The Contractor warrants to the Ministry that for a period of one year following the completion of crack sealing all work shall be free from defect resulting from work done or material supplied, and the Contractor shall rectify any such defects within 21 days from the time first detected by or reported to the Contractor to the satisfaction of the Ministry Representative.

MEASUREMENT

536.81 General - Pavement Crack Sealing will be measured by the LINEAR METRE using a line that is generally representative of the routed and/or cleaned crack..

Measuring will be done using a measuring wheel.

PAYMENT

536.91 General - Payment for PAVEMENT CRACK SEALING will be at the contract unit price bid per linear metre. The unit price shall be full compensation for all labour, equipment and material supplied as required to rout, clean and seal the pavement cracks, as specified.

SECTION 541

RUBBLE MASONRY

DESCRIPTION

541.01 Scope – This Section covers the construction of stone paving for grouted traffic island and median capping, dry-laid and grouted slope protection, culvert and spillway aprons, ditches and other like uses.

Paving rock minimum thickness of 100 to 200 mm will be specified depending upon location, use and setting requirements. Requirements for rock exceeding 200 mm minimum thickness are specified by SS 205 for hand-laid and grouted riprap.

MATERIALS

541.11 Materials

541.11.01 Rock – Rock for stone paving shall generally be obtained from the roadway excavation, stockpiled where designated and selected as necessary for use at the locations indicated on the Drawings, unless the supply of off-site rock is specified.

Rock will be required either as: angular rock as found or blasted, or rounded rock.

All rock shall be sound, durable and clean, relatively flat on the face to be exposed, reasonably consistent in colour tone, of acceptable size (200 to 450 mm across) and of the required thickness range.

541.11.02 Gravel Base – Gravel base shall be 25 mm minus well-graded crushed granular aggregate.

541.11.03 Bedding Mortar – Bedding mortar shall consist of one part Portland cement to three parts clean, well-graded fine aggregate or coarse sand mixed with water to give a 150 mm slump.

541.11.04 Setting and Jointing Mortar – Setting and jointing mortar shall consist of one part Portland cement to three parts clean, well-graded fine aggregate mixed with water to give a 75 mm slump.

CONSTRUCTION

541.31 Preparation – Graded surfaces to receive paving shall be trimmed and well tamped to the lines and grades indicated on the Drawings and to the approval of the Ministry Representative.

Edges of paving shall be constructed of thicker stones to form a stable foundation and protection against any undercutting in waterways.

All paved areas shall receive a minimum 150 mm layer of gravel base, well consolidated.

Gravel level inside curbs shall permit the surface of the jointing mortar to be flush with the top of the curb.

541.32 Construction – Construction shall be carried out with all material, labour, tools, equipment and incidentals supplied by the Contractor as necessary to complete all stone paving work in accordance with good work practice.

Gravel base of grouted stone paving shall be well saturated with bedding mortar slurry.

All rock shall be firmly embedded into the base material so that the voids between stones are of minimal width with the rock surfaces relatively even as indicated on Drawing SP541-01.

Voids of grouted paving rock shall be filled with setting and jointing mortar, 75 mm thick and, after consolidation and any necessary chinking of the larger voids, the mortar surface shall be smooth finished and sloped to drain freely.

Finished stone paving shall show a clean even appearance, free of disfiguring spalls and, where grouted, cleaned of mortar staining.

MEASUREMENT

541.81 General – Stone Paving work will be measured by the SQUARE METRE of stone in place.

PAYMENT

541.91 General – Payment for STONE PAVING work will be at the Contract Unit Price per square metre of stone in place.

The Contract Unit Price shall be accepted as full compensation for the supply of the gravel base, stone and mortar, for complete installation, including trimming and incidental excavation, compaction, finishing, and for all subsidiary work not required to be separately paid for.

TYPICAL SECTION THRU ROCK PAVING

SP541-01

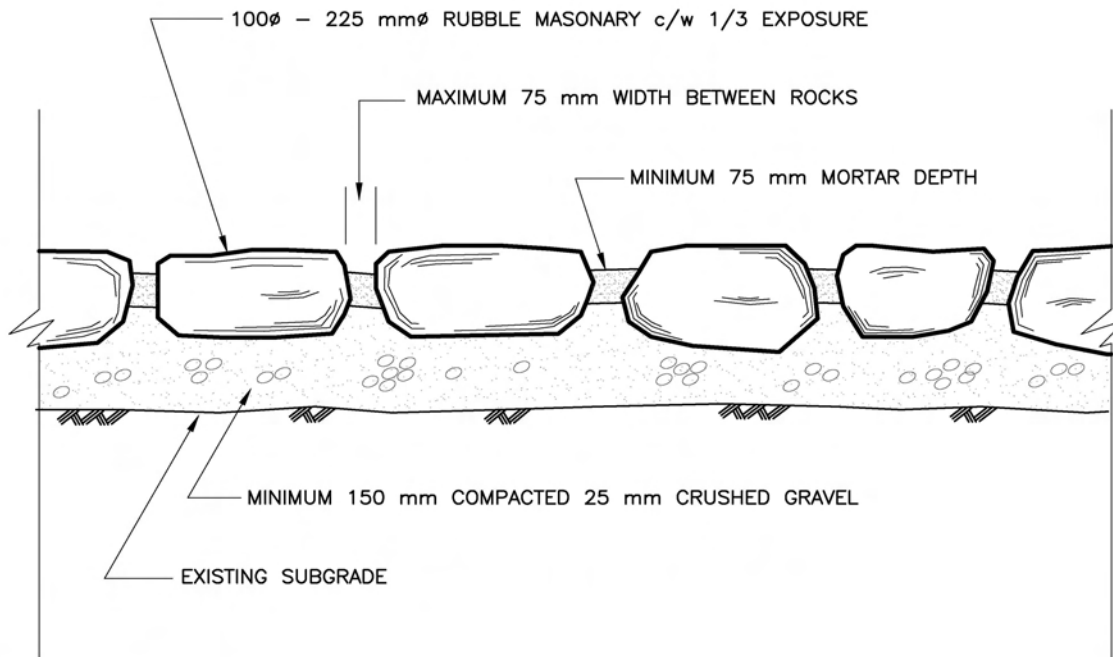

NOT TO SCALE

ALL DIMENSIONS ARE IN MILLIMETRES UNLESS OTHERWISE NOTED

SECTION 582

CONCRETE CURB AND GUTTER AND STORM DRAINAGE

DESCRIPTION

582.01 Scope – This Section describes the requirements for construction of roadside curb and gutter and associated underground drainage systems. Such work shall consist of constructing and/or installing appurtenances shown or indicated on the drawings and Schedule of Approximate Quantities and Unit Prices.

MATERIALS

582.11 Drain Pipe – All drain pipe shall be of first quality, sound, true in form and free from defects of all kinds.

582.12 Salt Glazed Clay Sewer Pipe – Salt glazed clay sewer pipe shall be in accordance with the current ASTM Specifications.

582.13 Concrete Pipe

582.13.01 Reinforced Concrete Pipe – Reinforced concrete pipe shall have joints of the tongue and groove type and shall meet the requirements of the current specification ASTM C 76 Series.

582.13.02 Plain Concrete Pipe – Plain concrete pipe shall meet the requirements of the current specification ASTM C 14 Series.

582.13.03 Requirements – Pipe shall be legibly marked with the date of manufacture, the name or trademark of the manufacturer and by marks denoting plain concrete pipe, reinforced concrete pipe or extra strength reinforced concrete pipe as the case may be. Pipe containing elliptically placed reinforcement shall be marked on the inside of the pipe with the words "Top" or "Bottom" at the correct place to indicate the proper position when laid.

Upon request, the Contractor shall furnish at the Contractor's expense such test and other information as may be required regarding the concrete pipe proposed to be used.

582.14 Corrugated Steel Pipe – Corrugated metal pipe shall conform to the requirements of SS 320.

CONSTRUCTION

582.31 Portland Cement Concrete Curb and Gutter – Combined Portland cement concrete curb and gutter shall be constructed to the line and grade shown on the Drawings or as otherwise directed by the Ministry Representative and will include returns at the intersections if so directed.

The combined curb and gutter shall be constructed to the standard cross-section shown on Drawing SP582-01.01 and to such layout plans as are attached, except where the face of the curb varies and at lanes and driveways where drop curbs are ordered.

Expansion joints 13 mm in thickness cut to the cross-section of the combined curb and gutter, composed of premoulded joint filler shall be installed at approximately 15 m intervals as directed by the Ministry Representative.

582.32 Catch Basins – Catch basins shall be constructed, where shown and as required in the Drawings or as the Ministry Representative may direct, in accordance with the intent of Drawings SP582-02.01 through SP582-02.05.

582.33 Manholes – Manholes shall be constructed at the locations and to invert levels shown in Drawings or as the Ministry Representative may direct in accordance with the intent of Drawings SP582-03.01 through SP582-03.08.

582.34 Storm Drains – Storm drains shall be constructed where shown on Drawings, or as directed by the Ministry Representative, and in accordance with the Drawings and specifications covering the various types and attached herewith. The trench and other preparatory work shall be approved by the Ministry Representative before actual placing starts.

582.35 Placing

582.35.01 Spigot and Bell Pipe – Spigot and bell pipe shall be laid beginning at the lower end with the bell end pointing up-grade. Suitable excavation or bedding must be provided to accommodate the bell so that the pipe is supported along its full length and not at the ends alone.

582.35.02 Concrete Pipe – Concrete pipe shall be laid beginning at the lower end with the groove end pointing up-grade. Pipe with elliptical reinforcement shall be laid with the minor axis of the reinforcement as marked by the manufacturer in a vertical position.

When jointing salt glazed clay and concrete pipes, the trench shall be in a dry condition and the joints shall be cleaned and wetted before sealing with mortar. The mortar shall consist of one part of Portland cement to two parts of fine sand, mixed to the proper consistency. Sealing shall be neatly and thoroughly done and the interior of the pipe cleaned of all surplus mortar. Joints shall be kept damp with burlap or earth for at least three days after sealing.

582.35.03 Corrugated Steel Pipe – Corrugated steel pipe shall be laid beginning at the lower end with the outside laps pointing up-grade and the longitudinal joint on the side. The separate sections shall be firmly jointed together and any metal in joints which is not thoroughly protected by galvanizing shall be coated with a suitable asphaltum paint.

582.35.04 General – The Contractor shall provide and fix at such points, as may be directed, properly painted

substantial sight rails set to correct levels. At least three sight rails shall be in position for each length of sewer. Pipes shall be accurately set and laid to even gradients, concentric and in straight lines between manholes.

582.36 Special Jointing Material – Where pipe trenches are necessarily restricted in width or where unavoidable wet conditions exist, which would prevent proper normal jointing of pipes with Portland cement mortar, special prefabricated joints may be authorized to be used. In such a case, the Ministry will pay the Contractor for providing such jointing material at net cost after deducting all trade discounting and commissions. The Contractor shall install the prefabricated jointing material instead of cement mortar jointing at no extra cost.

582.37 Bedding and Backfilling – The bedding of all concrete pipes shall consist of 19 mm or 25 mm crushed gravel to a minimum depth of 150 mm below the pipe. The backfill shall consist of 19 mm or 25 mm crushed gravel with a minimum cover of 150 mm and in the remainder of the trench shall consist of the natural excavated material unless such material is considered unsuitable by the Ministry Representative. Such natural material shall have a maximum size of 75 mm. All materials shall be compacted in horizontal layers not more than 200 mm.

582.38 Concrete End Walls – See SS 303.31.06.

MEASUREMENT

582.81 Portland Cement Concrete Curb and Gutter – Portland Cement Concrete Curb and Gutter will be measured by the METRE.

582.82 Catch Basins – Catch Basins will be measured per EACH.

582.83 Manholes – Manholes will be measured per EACH.

The Contractor shall allow in the bid price for the construction of manholes having an overall depth of concrete section of 2 m (see dimensions marked "variable"). In addition, the Contractor shall bid a price per 0.3 m of depth of manhole, which shall be added to or subtracted from the bid price for the manhole depending on the actual depth of the manhole to be constructed.

582.84 Storm Drains – Storm drains will be measured by the METRE in place.

582.85 Bedding and Backfill – Bedding and backfill will be measured by the CUBIC METRE in place.

582.86 Concrete End Walls – See SS 303.07.01.

PAYMENT

582.91 Portland Cement Concrete Curb and Gutter – Payment for combined Portland cement CONCRETE CURB AND GUTTER will be at the Contract Unit Price per metre. The Contract Unit Price shall include everything furnished and done in connection with form setting, supply and placing of air entrained concrete; supply and installation of expansion joints; finishing, curing, protection and superintendence.

582.92 Catch Basins – Payment for CATCH BASINS will be at the Contact Unit Price per each. The Contract Unit Price shall include everything furnished and done; excavation, backfilling and tamping around catch basins, formwork, concreting, setting in of pipe drains, setting and securing of cast iron catch basin frames and gratings, steel baffles, reinstatement of surface, cleaning out, protection and superintendence and, all other things necessary.

582.93 Manholes – Payment for MANHOLES will be at the Contract Unit Price per standard 2 m manhole with appropriate depth correction as described in SS 582.83. The Contract Unit Price shall include everything furnished and done; formwork, concreting, setting in of storm drains, construction of smooth invert sections, cement mortar settings, steel ladder rungs, brick construction, setting of manhole frames and covers, cleaning out, protection and superintendence, and all other things necessary.

582.94 Storm Drains – Payment for STORM DRAINS will be at the Contract Unit Price per metre in place. The Contract Unit Price shall be accepted as full compensation for everything furnished and everything done in connection herewith, but shall not include payment for excavation, riprap, paving, concrete cradles, end walls, bedding and backfill. These shall be paid for at their respective prices in the Schedule of Approximate Quantities and Unit Prices.

582.95 Bedding and Backfill – Payment for BEDDING and BACKFILL will be at the Contract Unit Price per cubic metre in place.

582.96 Concrete End Walls – See SS 303.07.02

COMBINED CURB AND GUTTER

SP582-01.01

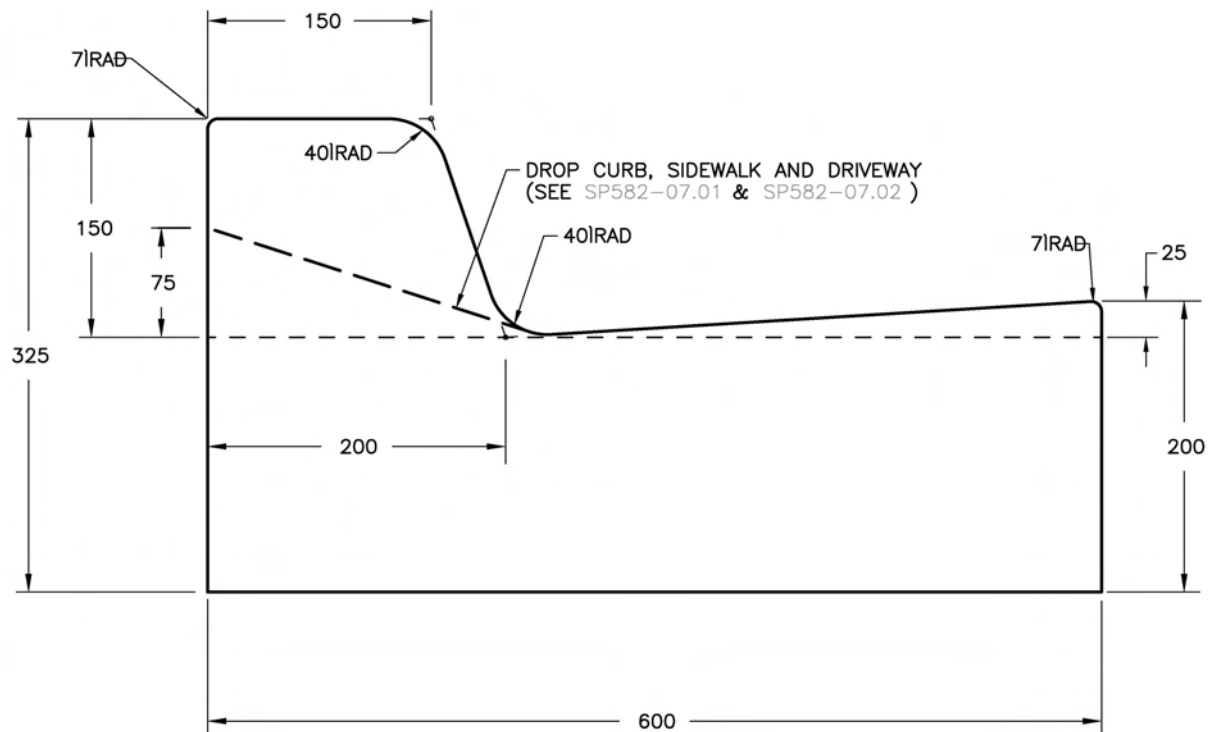
**NOTES:**

1. THE CONCRETE INCORPORATED IN THE CURB SHALL HAVE:
 - MINIMUM COMPRESSIVE STRENGTH OF 30 MPa AT 28 DAYS;
 - COARSE AGGREGATE OF MAXIMUM PARTICLE SIZE NOT EXCEEDING 25 mm;
 - MINIMUM CEMENT CONTENT OF 350 kg/m³;
 - ENTRAINED AIR OF 6 - 8%;
 - SLUMP: BETWEEN 10 mm AND 25 mm FOR EXTRUDED
MAXIMUM 65 mm FOR POURED IN PLACE;
 - MAXIMUM WATER - CEMENT RATIO OF 0.45.
2. CONTRACTION JOINTS SHALL BE CUT AND TOOLED INTO THE CONCRETE TO A DEPTH 60% OF THE THICKNESS OF THE CONCRETE AT INTERVALS OF 3 m.
3. EXPANSION JOINTS 13 mm IN THICKNESS CUT TO THE CROSS-SECTION OF THE COMBINED CURB AND GUTTER, COMPOSED OF PREMOULDED JOINT FILLER SHALL BE INSTALLED AT APPROXIMATELY 15 m INTERVALS AS WELL AS AT CURB RETURNS, EITHER SIDE OF DRIVEWAYS AND OTHER LOCATIONS AS DIRECTED BY THE MINISTRY REPRESENTATIVE.

NOT TO SCALE

ALL DIMENSIONS ARE IN MILLIMETRES UNLESS OTHERWISE NOTED

MOUNTABLE CURB AND GUTTER

SP582-01.02

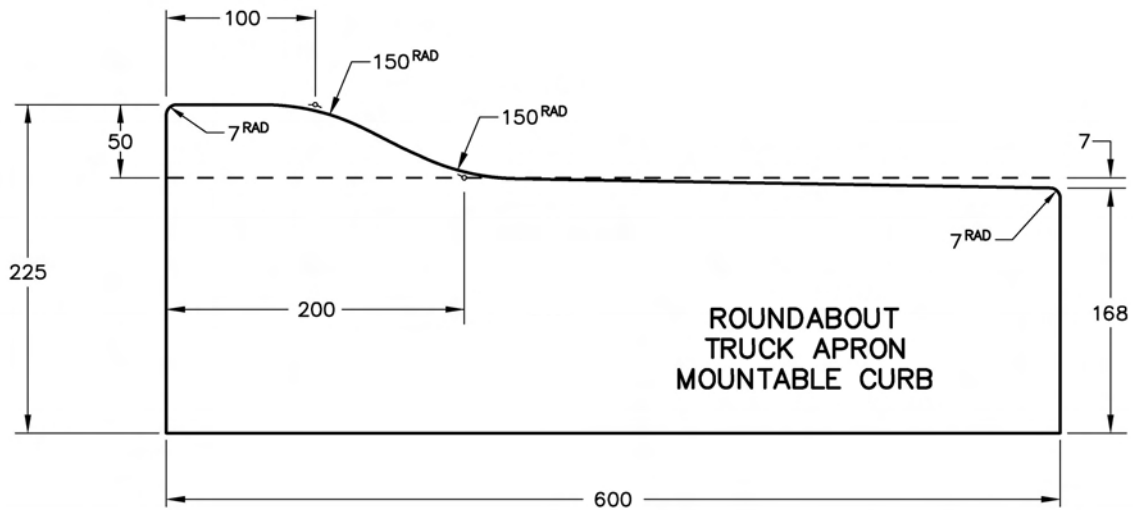
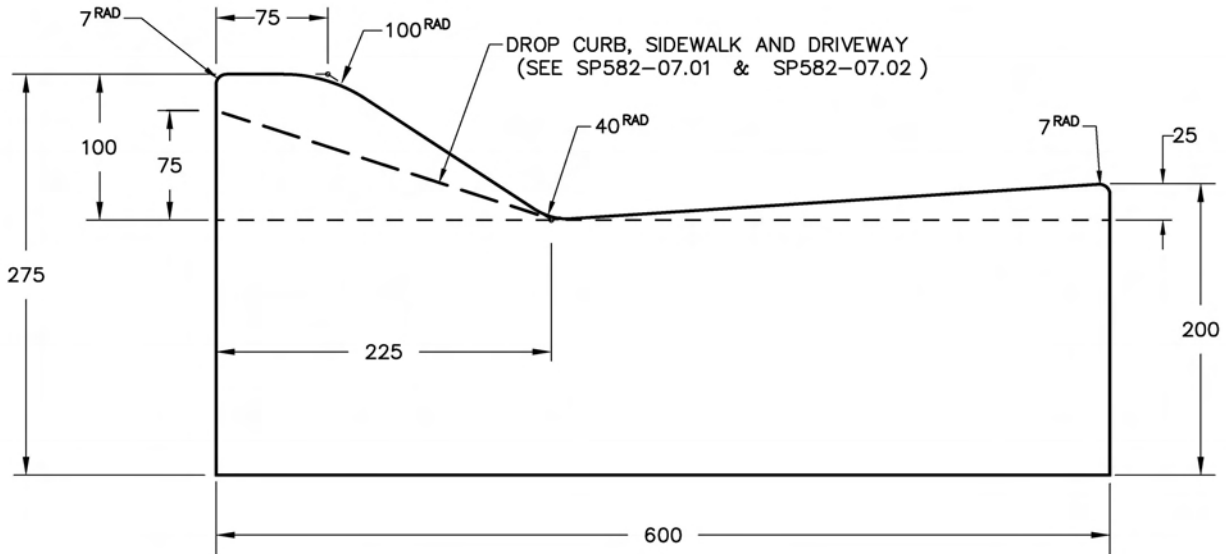

NOTES:

1. THE CONCRETE INCORPORATED IN THE CURB SHALL HAVE:
 - MINIMUM COMPRESSIVE STRENGTH OF 30 MPa AT 28 DAYS;
 - COARSE AGGREGATE OF MAXIMUM PARTICLE SIZE NOT EXCEEDING 25 mm;
 - MINIMUM CEMENT CONTENT OF 350 kg/m³;
 - ENTRAINED AIR OF 6% to 8%;
 - SLUMP: BETWEEN 10 mm AND 25 mm FOR EXTRUDED, MAXIMUM 65 mm FOR POURED IN PLACE;
 - MAXIMUM WATER/CEMENT RATIO OF 0.45.
2. CONTRACTION JOINTS SHALL BE CUT AND TOOLED INTO THE CONCRETE TO A DEPTH 60% OF THE THICKNESS OF THE CONCRETE AT INTERVALS OF 3 m.
3. EXPANSION JOINTS 13 mm IN THICKNESS CUT TO THE CROSS-SECTION OF THE COMBINED CURB AND GUTTER, COMPOSED OF PREMOULDED JOINT FILLER SHALL BE INSTALLED AT APPROXIMATELY 15 m INTERVALS AS WELL AS AT CURB RETURNS, EITHER SIDE OF DRIVEWAYS AND OTHER LOCATIONS AS DIRECTED BY THE MINISTRY REPRESENTATIVE.

NOT TO SCALE

ALL DIMENSIONS ARE IN MILLIMETRES UNLESS OTHERWISE NOTED

VALLEY CURB AND GUTTER

SP582-01.03

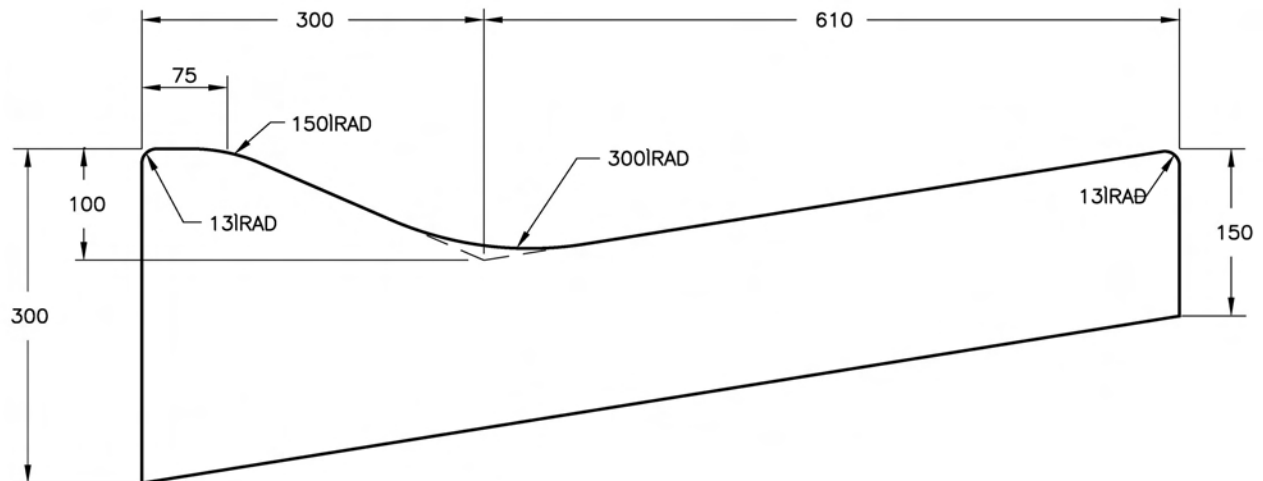
**NOTES:**

1. THE CONCRETE INCORPORATED IN THE CURB SHALL HAVE:
 - MINIMUM COMPRESSIVE STRENGTH OF 30 MPa AT 28 DAYS;
 - COARSE AGGREGATE OF MAXIMUM PARTICLE SIZE NOT EXCEEDING 25 mm;
 - MINIMUM CEMENT CONTENT OF 350 kg/m³;
 - ENTRAINED AIR OF 6 - 8%;
 - SLUMP: BETWEEN 10 mm AND 25 mm FOR EXTRUDED
MAXIMUM 65 mm FOR POURED IN PLACE;
 - MAXIMUM WATER - CEMENT RATIO OF 0.45.
2. CONTRACTION JOINTS SHALL BE CUT AND TOOLED INTO THE CONCRETE TO A DEPTH 60% OF THE THICKNESS OF THE CONCRETE AT INTERVALS OF 3 m.
3. EXPANSION JOINTS 13 mm IN THICKNESS CUT TO THE CROSS-SECTION OF THE COMBINED CURB AND GUTTER, COMPOSED OF PREMOULDED JOINT FILLER SHALL BE INSTALLED AT APPROXIMATELY 15 m INTERVALS AS WELL AS AT CURB RETURNS, EITHER SIDE OF DRIVEWAYS AND OTHER LOCATIONS AS DIRECTED BY THE MINISTRY REPRESENTATIVE.

NOT TO SCALE

ALL DIMENSIONS ARE IN MILLIMETRES UNLESS OTHERWISE NOTED

ISLAND OR MEDIAN CURB

SP582-01.04

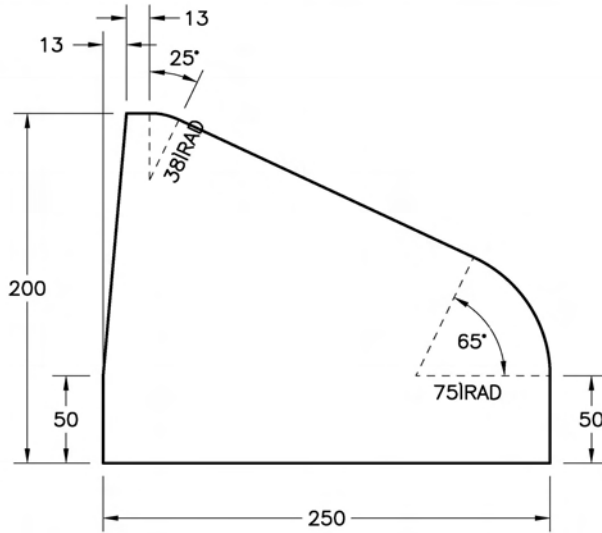

EXTRUDED CONCRETE CURB FOR ISLANDS & MEDIANS

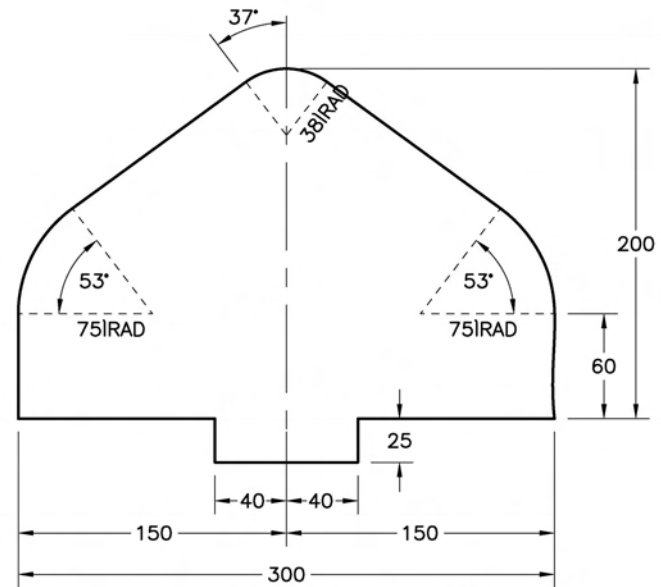

EXTRUDED CONCRETE CURB CENTER DIVIDER

TYPICAL SECTIONS

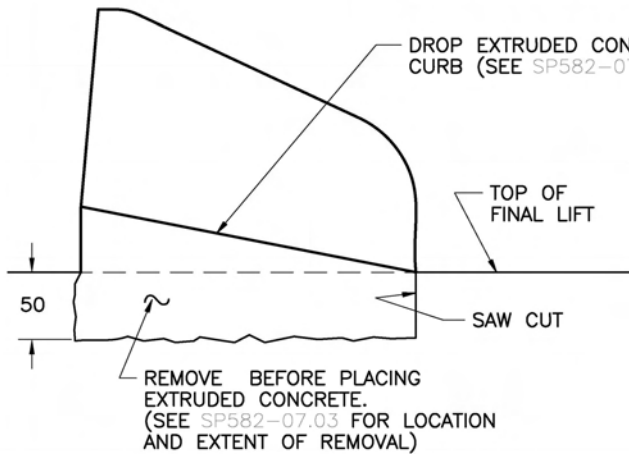

FINAL LIFT IN PLACE

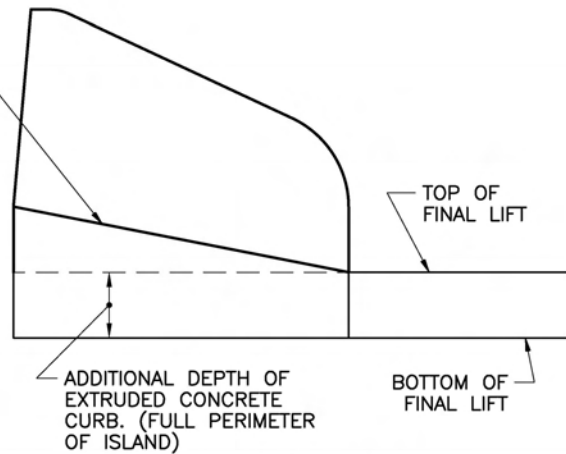

FINAL LIFT NOT IN PLACE

SECTIONS THRU ISLAND RAMP CURBS

NOTES:

- THE CONCRETE INCORPORATED IN THE CURB SHALL HAVE:
 - MINIMUM COMPRESSIVE STRENGTH OF 30 MPa AT 28 DAYS;
 - COARSE AGGREGATE OF MAXIMUM PARTICLE SIZE NOT EXCEEDING 25 mm;
 - MINIMUM CEMENT CONTENT OF 350 kg/m³;
 - ENTRAINED AIR OF 6 - 8%;
 - SLUMP: BETWEEN 10 mm AND 25 mm;
 - MAXIMUM WATER - CEMENT RATIO OF 0.45.

- CONTRACTION JOINTS SHALL BE CUT AND TOOLED INTO THE CONCRETE TO A DEPTH 60% OF THE THICKNESS OF THE CONCRETE AT INTERVALS OF 3 m.

NOT TO SCALE

ALL DIMENSIONS ARE IN MILLIMETRES UNLESS OTHERWISE NOTED

PRECAST REINFORCED CONCRETE CATCH BASIN

SP582-02.01

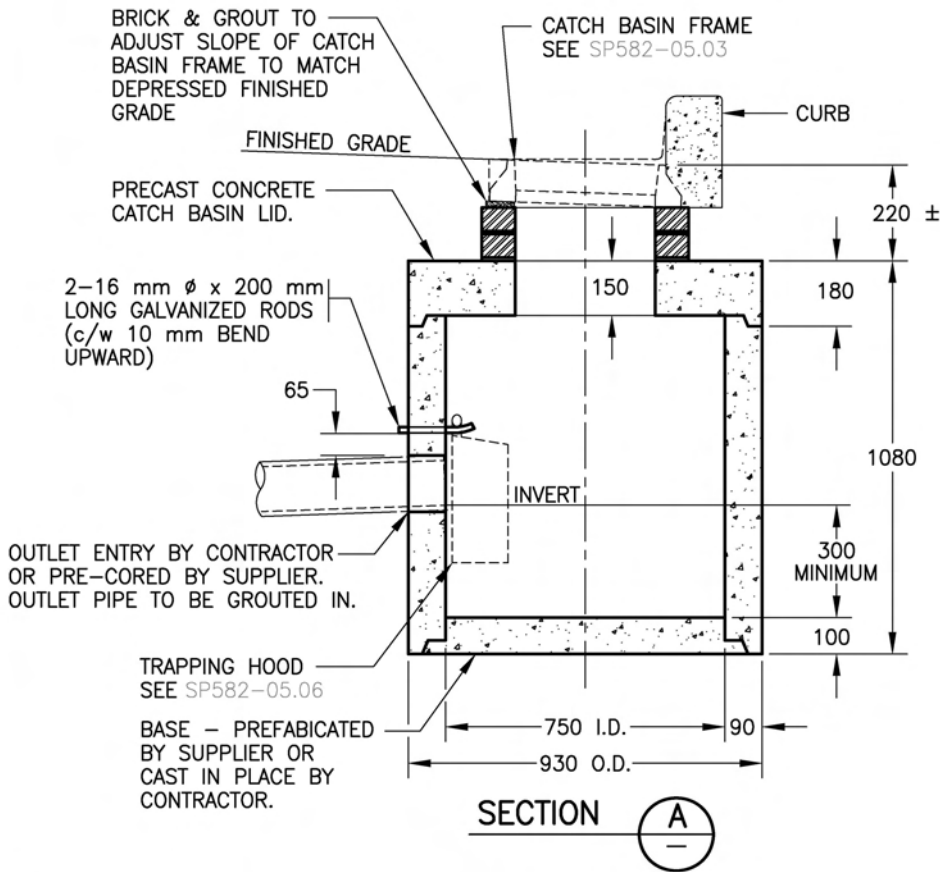
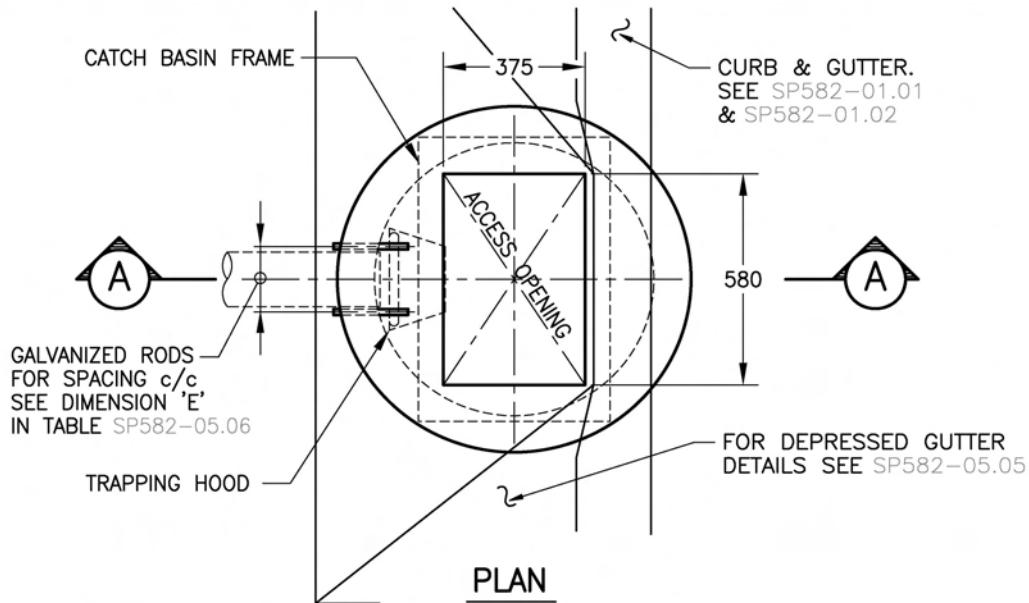

NOTES:

1. ALL CAST IN PLACE CONCRETE TO BE CLASS 'A' (SEE SECTION 218).
2. ALL PRECAST WORK TO CONFORM TO ASTM C 478M.
3. CATCH BASIN LID TO WITHSTAND HS 20 LOADING.

NOT TO SCALE

ALL DIMENSIONS ARE IN MILLIMETRES UNLESS OTHERWISE NOTED

PRECAST REINFORCED CONCRETE
VARIABLE DEPTH CATCH BASIN

SP582-02.02

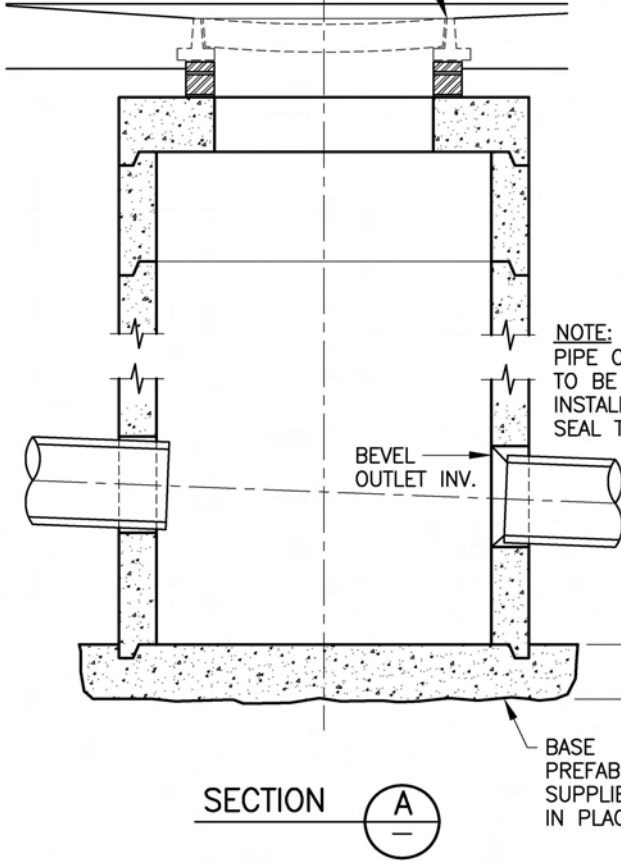
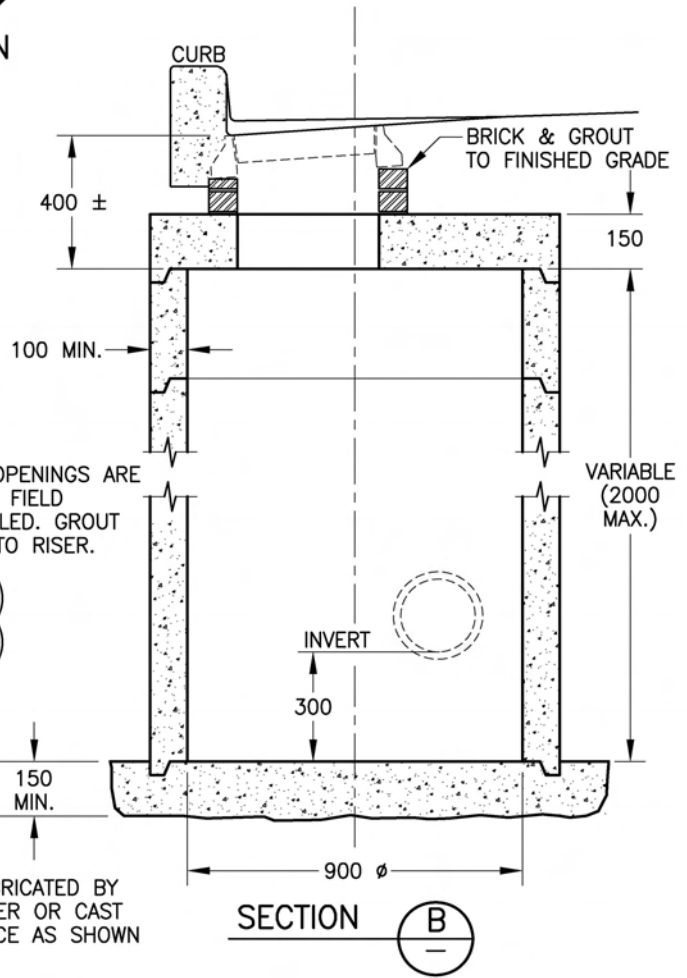
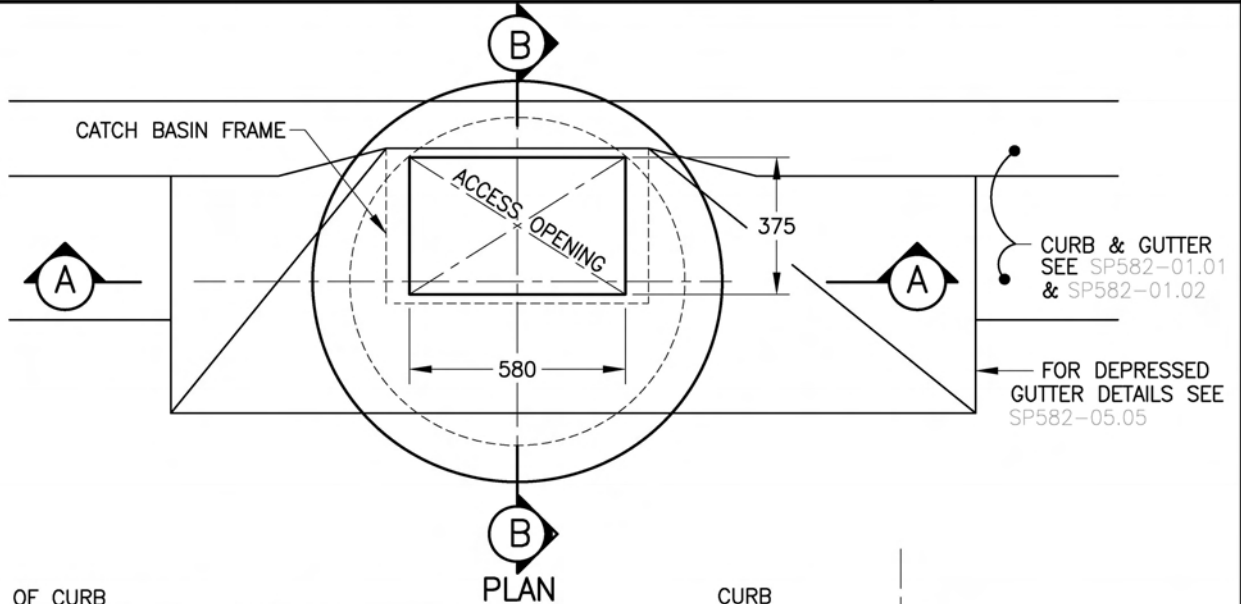

NOTES:

1. ALL CAST IN PLACE CONCRETE TO BE CLASS 'A' (SEE SECTION 218).
2. ALL PRECAST WORK TO CONFORM TO ASTM C 478M.
3. CATCH BASIN LID TO WITHSTAND HS 20 LOADING.

NOT TO SCALE

ALL DIMENSIONS ARE IN MILLIMETRES UNLESS OTHERWISE NOTED

CAST IN PLACE CONCRETE CATCH BASIN

SP582-02.03

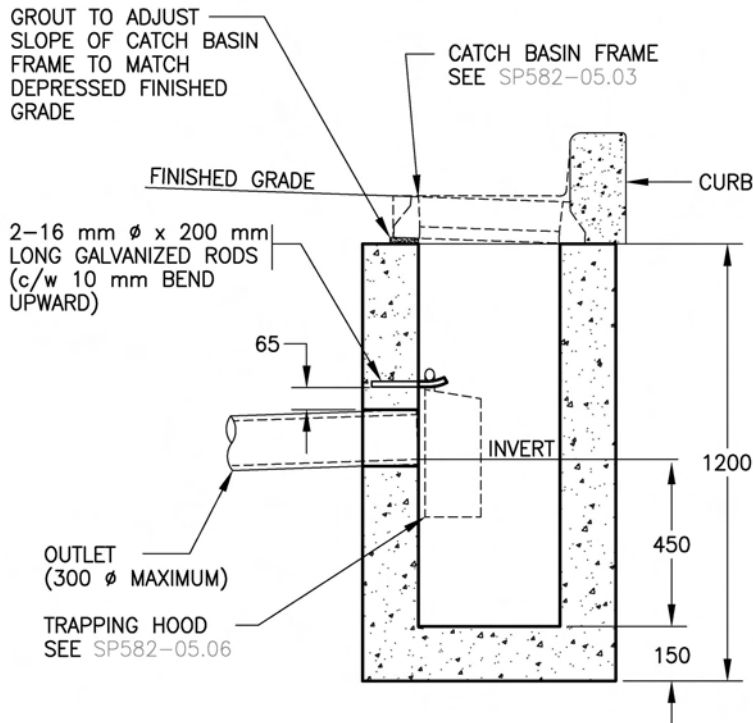
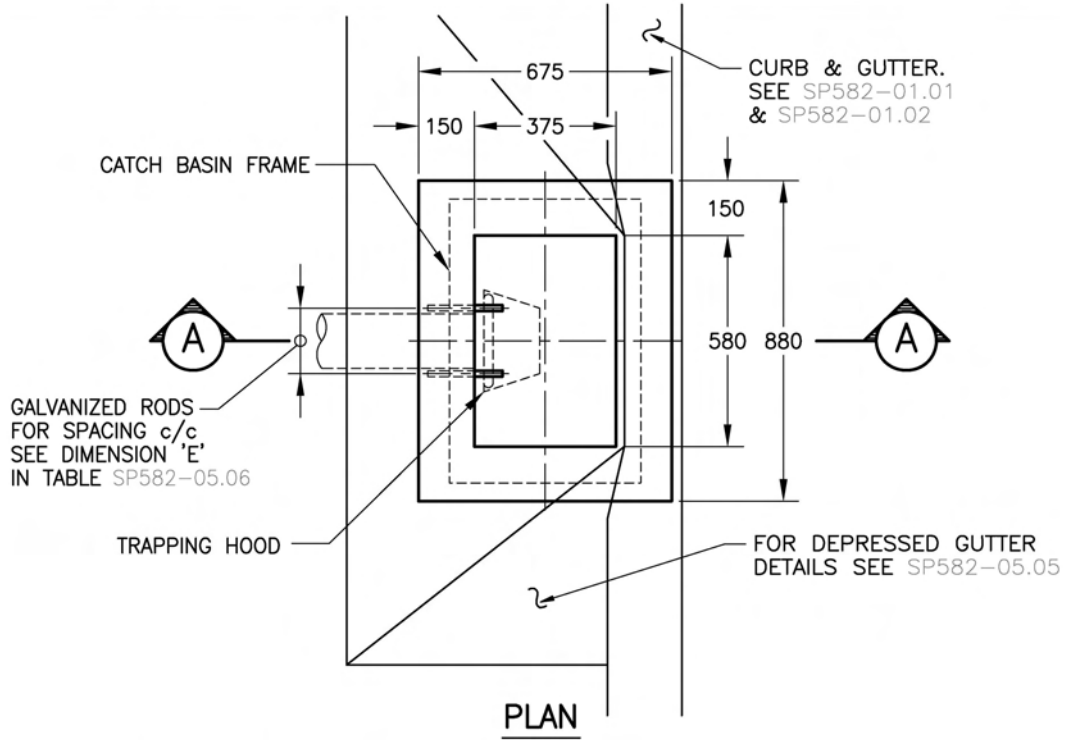

NOTE:
ALL CONCRETE TO BE CLASS 'A'
(SEE SECTION 218).

SECTION A

NOT TO SCALE

ALL DIMENSIONS ARE IN MILLIMETRES UNLESS OTHERWISE NOTED

CORRUGATED STEEL CATCH BASIN

SP582-02.04

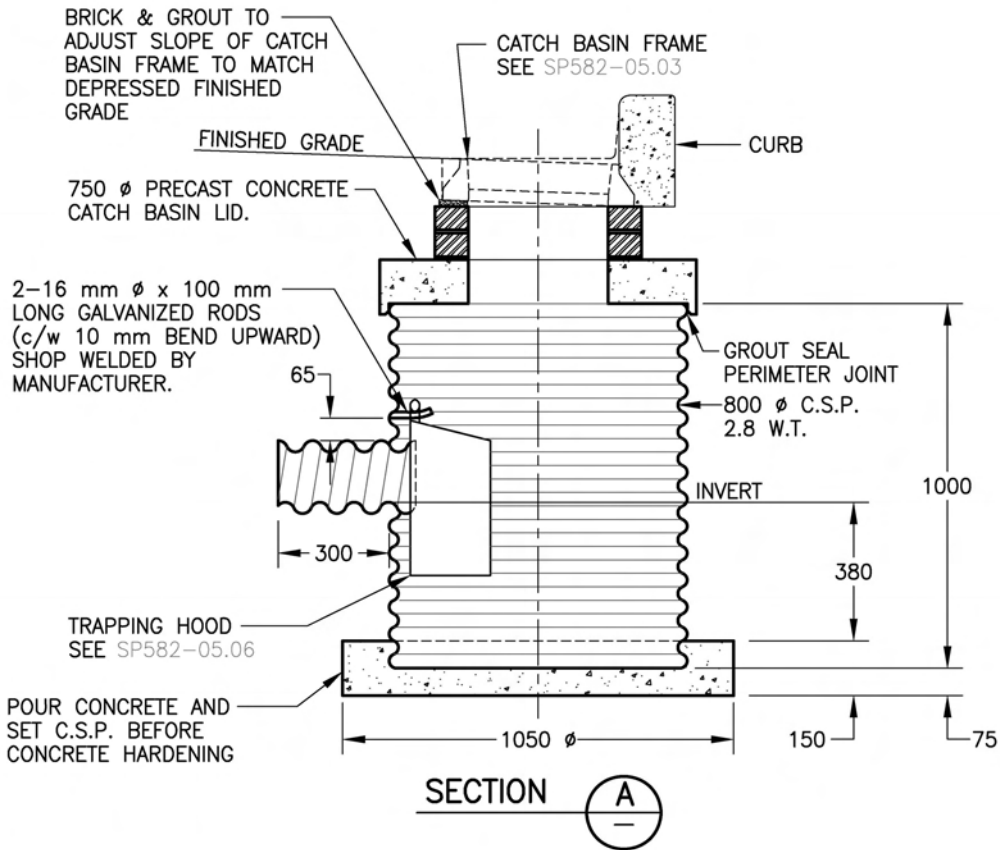
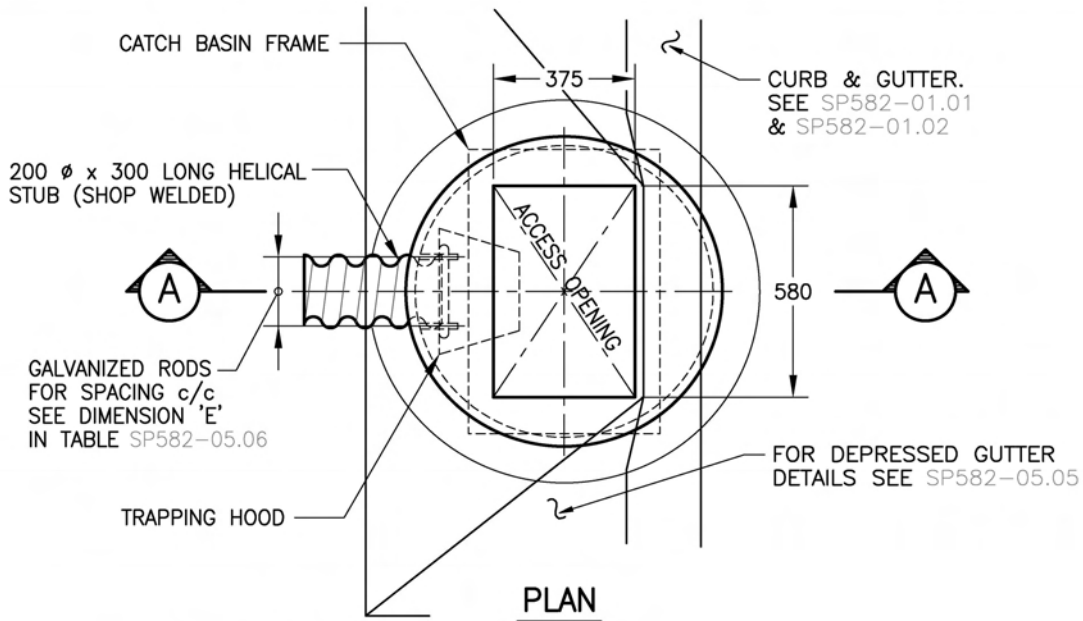

NOTES:

1. ALL CAST IN PLACE CONCRETE TO BE CLASS 'A' (SEE SECTION 218).
2. ALL PRECAST WORK TO CONFORM TO ASTM C 478M.
3. CATCH BASIN LID TO WITHSTAND HS 20 LOADING.

NOT TO SCALE

ALL DIMENSIONS ARE IN MILLIMETRES UNLESS OTHERWISE NOTED

CAST IRON CATCH BASIN BOX AND ADAPTOR PLATE

SP582-02.05

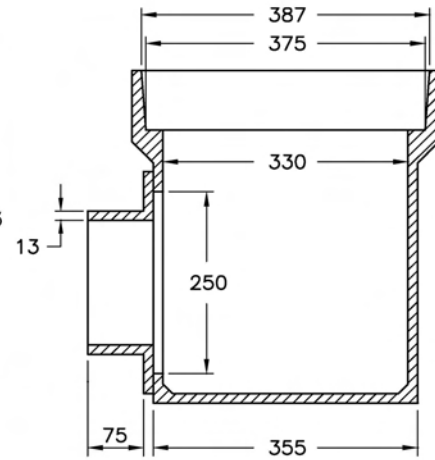
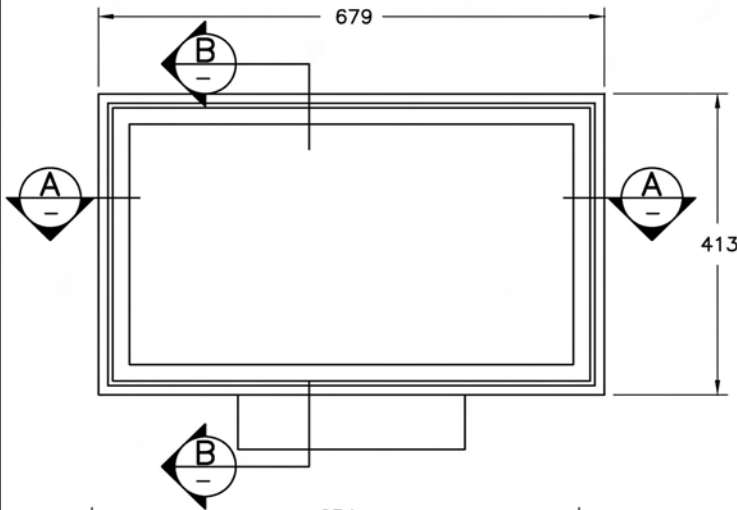

SECTION **B**

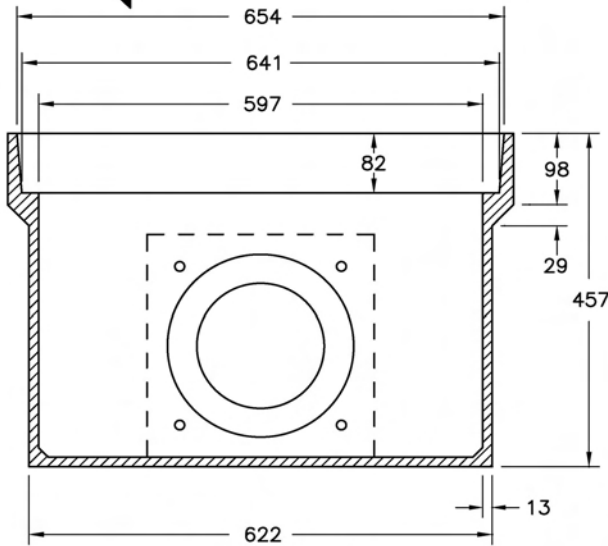

SECTION **A**

NOTE:
 THIS CATCH BASIN BOX IS TO BE USED IN CONJUNCTION WITH A STANDARD CATCH BASIN GRATE (SEE SP582-05.01 OR SP582-05.02). MATERIAL TO BE CAST STEEL OR CAST IRON AS ORDERED. APPROXIMATE WEIGHT 136 kg

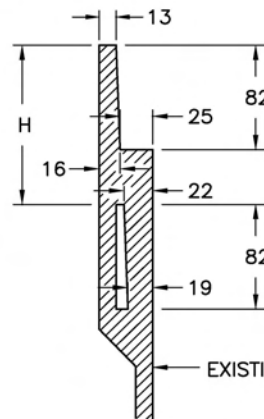

HEIGHT H TYPE A....100
 TYPE B....125
 TYPE C....150

OUTSIDE DIMENSIONS OF CAST IRON EXTENSION ARE 679 x 413

EXISTING CAST IRON CATCH BASIN BOX

EXTENSION FOR CAST IRON CATCH BASIN BOX

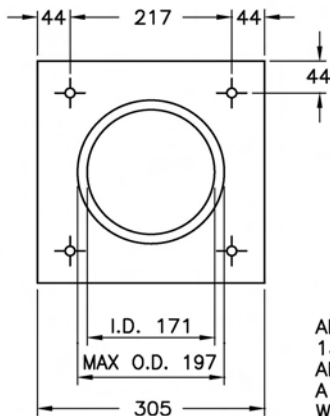

ADAPTOR PLATE

ADAPTOR PLATE TO BE DRILLED TO CLEAR 13 mm STUDS. THE FACE OF THE BOX AND PLATE TO BE GROUND SMOOTH, AND A RUBBER GASKET USED TO ENSURE A WATER TIGHT JOINT.

NOT TO SCALE

ALL DIMENSIONS ARE IN MILLIMETRES UNLESS OTHERWISE NOTED

PRECAST REINFORCED CONCRETE MANHOLE

SP582-03.01

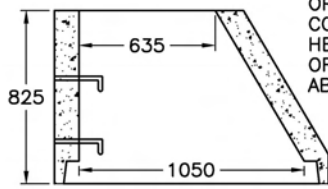

1050 mm TO 625 mm
MANHOLE REDUCING CONE

OPTIONAL BY DESIGNER.
CONSIDERED ONLY WHEN
HEIGHT ALLOWS BOTTOM
OF CONE TO BE 2 m
ABOVE INVERT.

SUPPLIER TO INSTALL
19Ø GALVANIZED LADDER
RUNGS OR PREAPPROVED
ALTERNATIVE AS PER
SUBSECTION 145.15.03
RUNGS TO BE HOOKED
AS SHOWN OR WELDED
TO REINFORCING MESH.

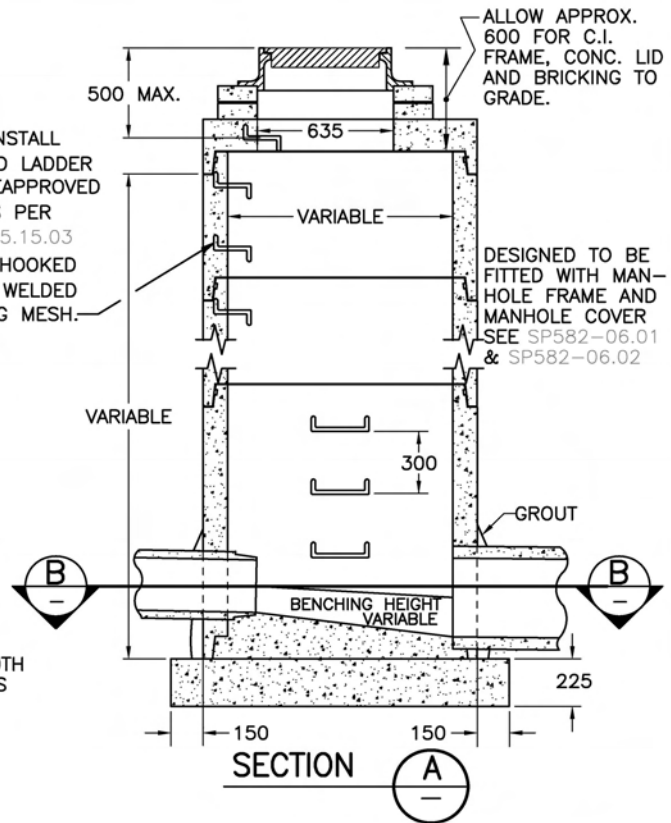
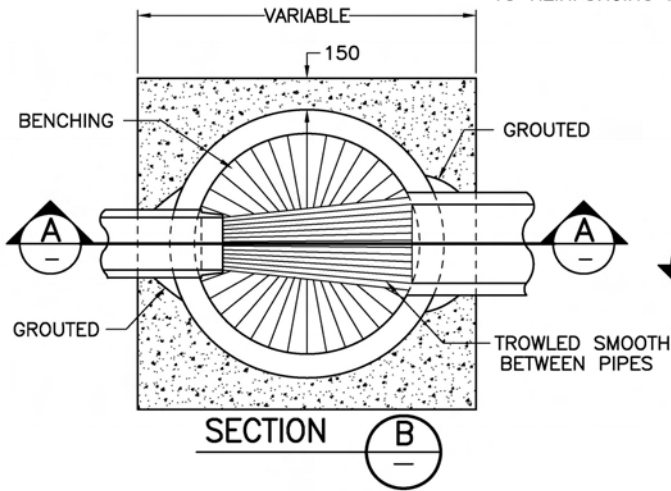

ALLOW APPROX.
600 FOR C.I.
FRAME, CONC. LID
AND BRICKING TO
GRADE.

DESIGNED TO BE
FITTED WITH MAN-
HOLE FRAME AND
MANHOLE COVER
SEE SP582-06.01
& SP582-06.02

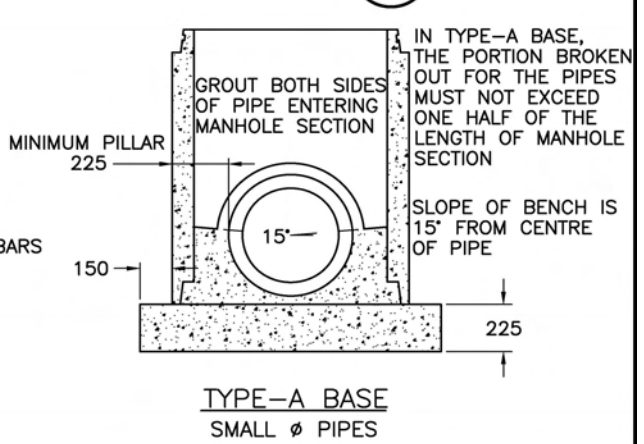
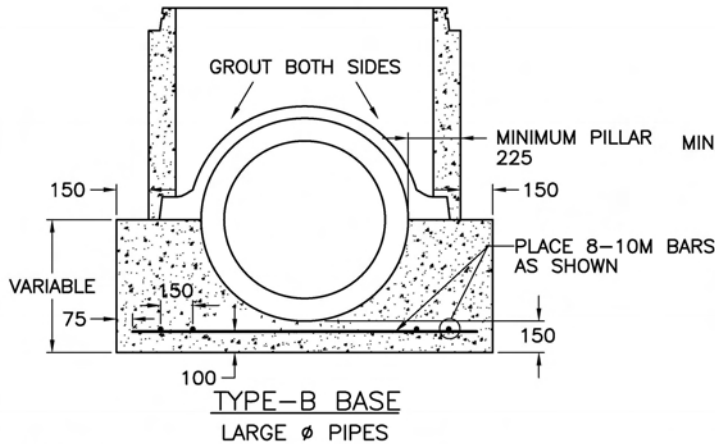

IN TYPE-A BASE,
THE PORTION BROKEN
OUT FOR THE PIPES
MUST NOT EXCEED
ONE HALF OF THE
LENGTH OF MANHOLE
SECTION

SLOPE OF BENCH IS
15° FROM CENTRE
OF PIPE

CONSTRUCTION SEQUENCE

1. POUR A SQUARE CONCRETE BASE 225 mm THICK AND 300 mm WIDER THAN THE OUTSIDE OF THE MANHOLE SECTION.
2. BREAK PIPE ENTRANCES INTO MANHOLE SECTION, SET MANHOLE SECTION OVER THE PIPES ON THE CONCRETE BASE.
3. POUR A CONCRETE BENCH TO THE CENTRE POINT OF THE PIPE AND SLOPE OF 15°.
4. THOROUGHLY GROUT AROUND PIPES ENTERING MANHOLES.

MANHOLE SECTIONS			REINFORCED LIDS		MAX. PIPE	
INSIDE DIA.	MASS	W.T.	THICK	MASS	BASE "A"	BASE "B"
750	630 kg	89	150	170 kg	375	375
900	870 kg	102	150	290 kg	530	530
1050	1115 kg	114	260	475 kg	610	685
1200	1390 kg	127	310	930 kg		760
1350	2010 kg	159	310	1125 kg		915
1500	2370 kg	171	370	1485 kg		1065
1800	3245 kg	197	380	2420 kg		1370

NOTES:

1. ALL CAST IN PLACE CONCRETE TO BE CLASS 'A' (SEE SECTION 218).
2. ALL PRECAST WORK TO CONFORM TO ASTM C 478M.
3. MANHOLE LID TO WITHSTAND HS 20 LOADING.

NOT TO SCALE

ALL DIMENSIONS ARE IN MILLIMETRES UNLESS OTHERWISE NOTED

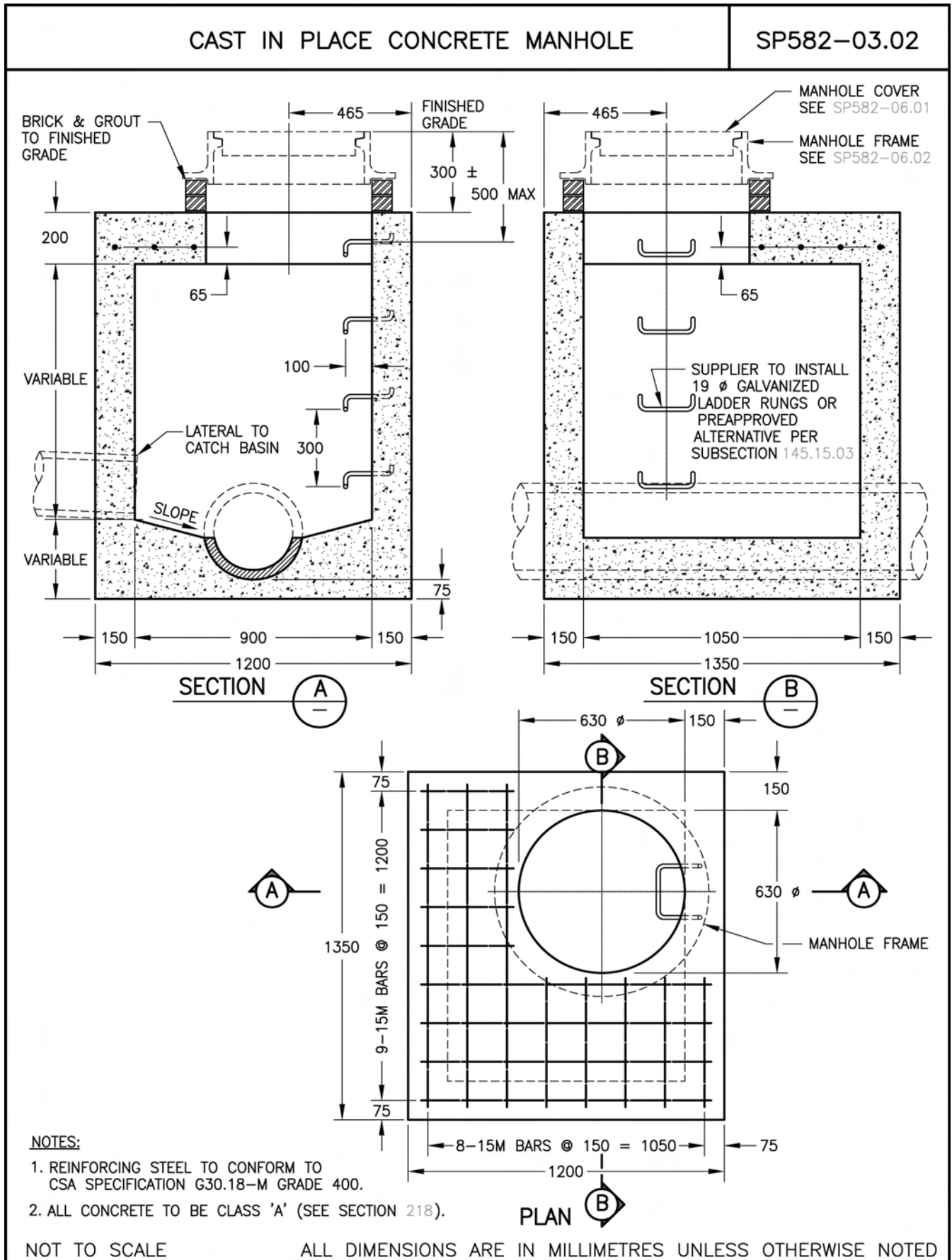

PREFABRICATED CONCRETE TEE MANHOLES
PIPE SIZES – 300 mm TO 675 mm

SP582-03.03

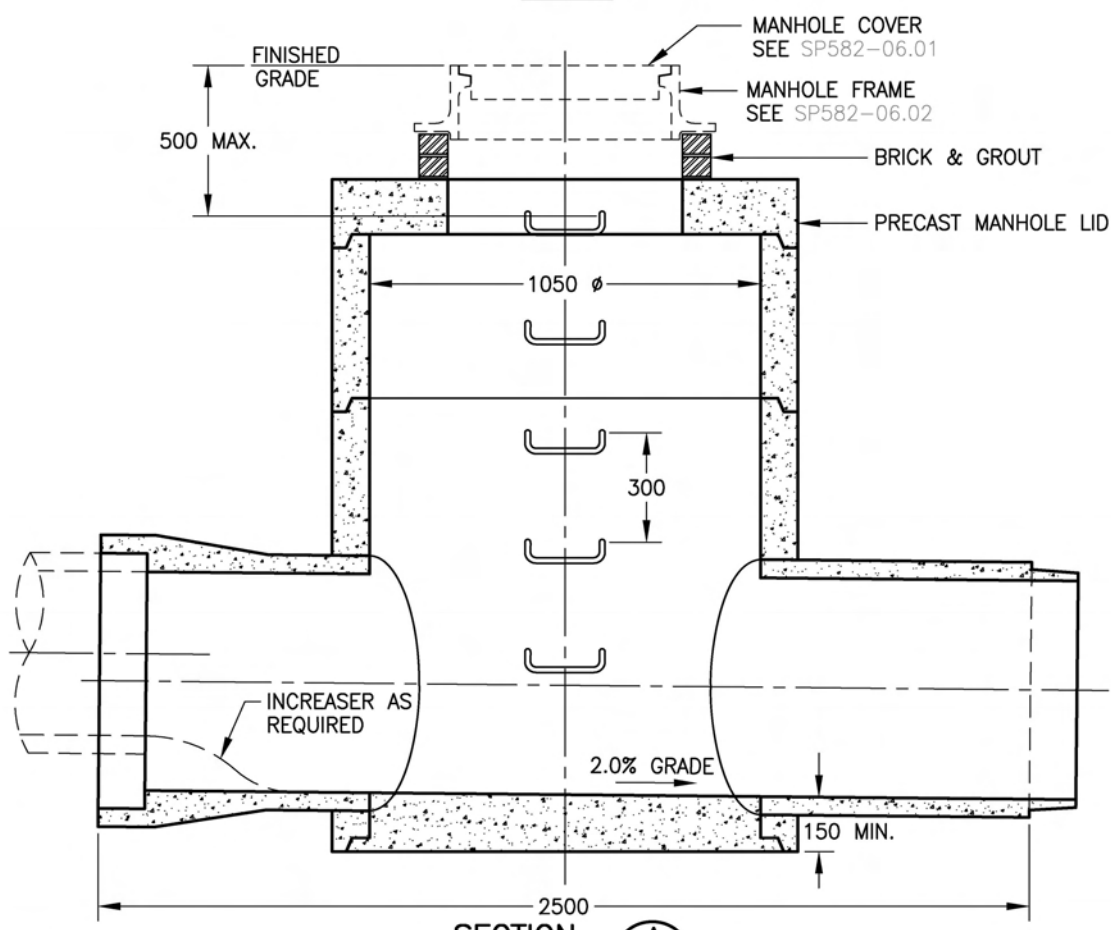
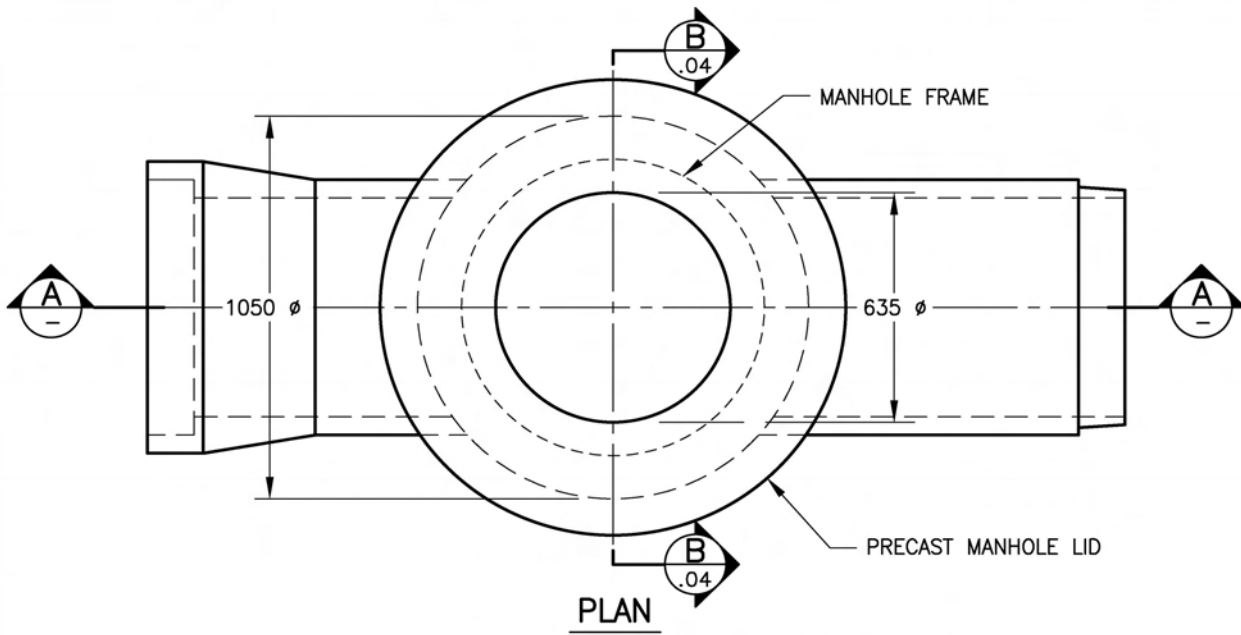

NOTE:
FOR GENERAL NOTES SEE SP582-03.06

SECTION A

NOT TO SCALE

ALL DIMENSIONS ARE IN MILLIMETRES UNLESS OTHERWISE NOTED

PREFABRICATED CONCRETE TEE MANHOLES
PIPE SIZES – 300 mm TO 675 mm

SP582-03.04

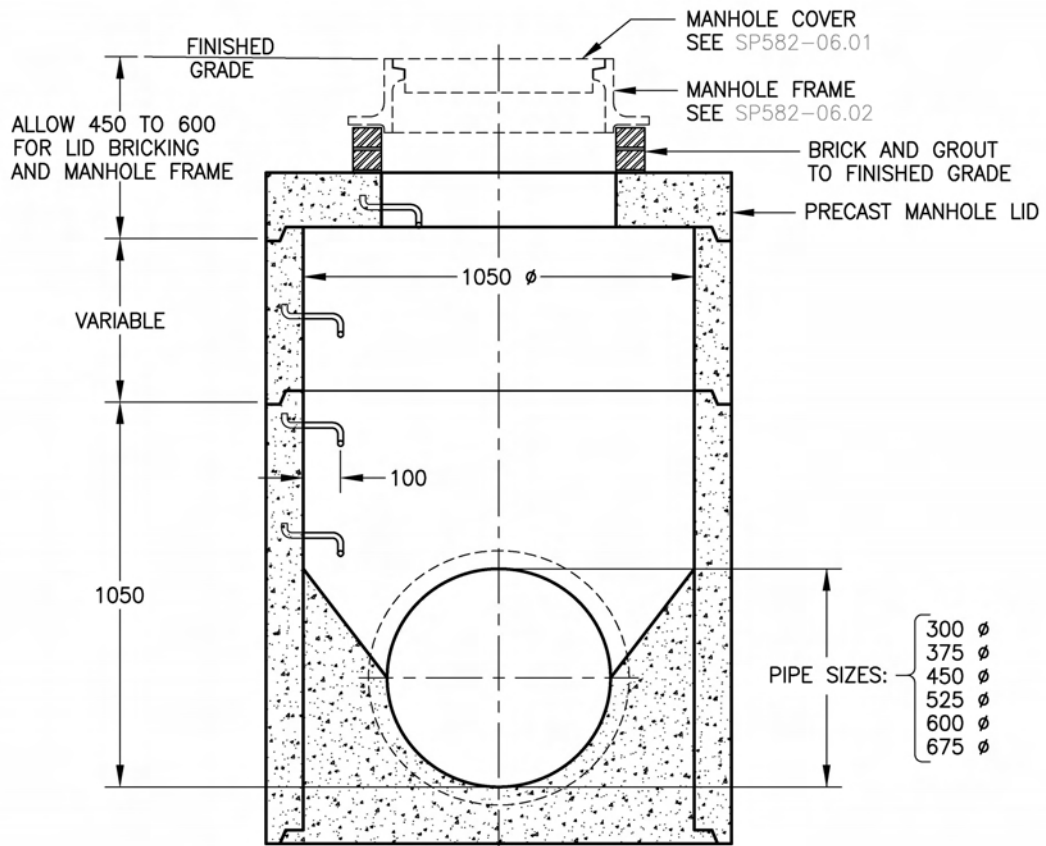

SECTION B
03

NOTE: FOR LOCATION OF SECTION SEE SP582-03.03

NOTE:
FOR GENERAL NOTES SEE SP582-03.06

NOT TO SCALE

ALL DIMENSIONS ARE IN MILLIMETRES UNLESS OTHERWISE NOTED

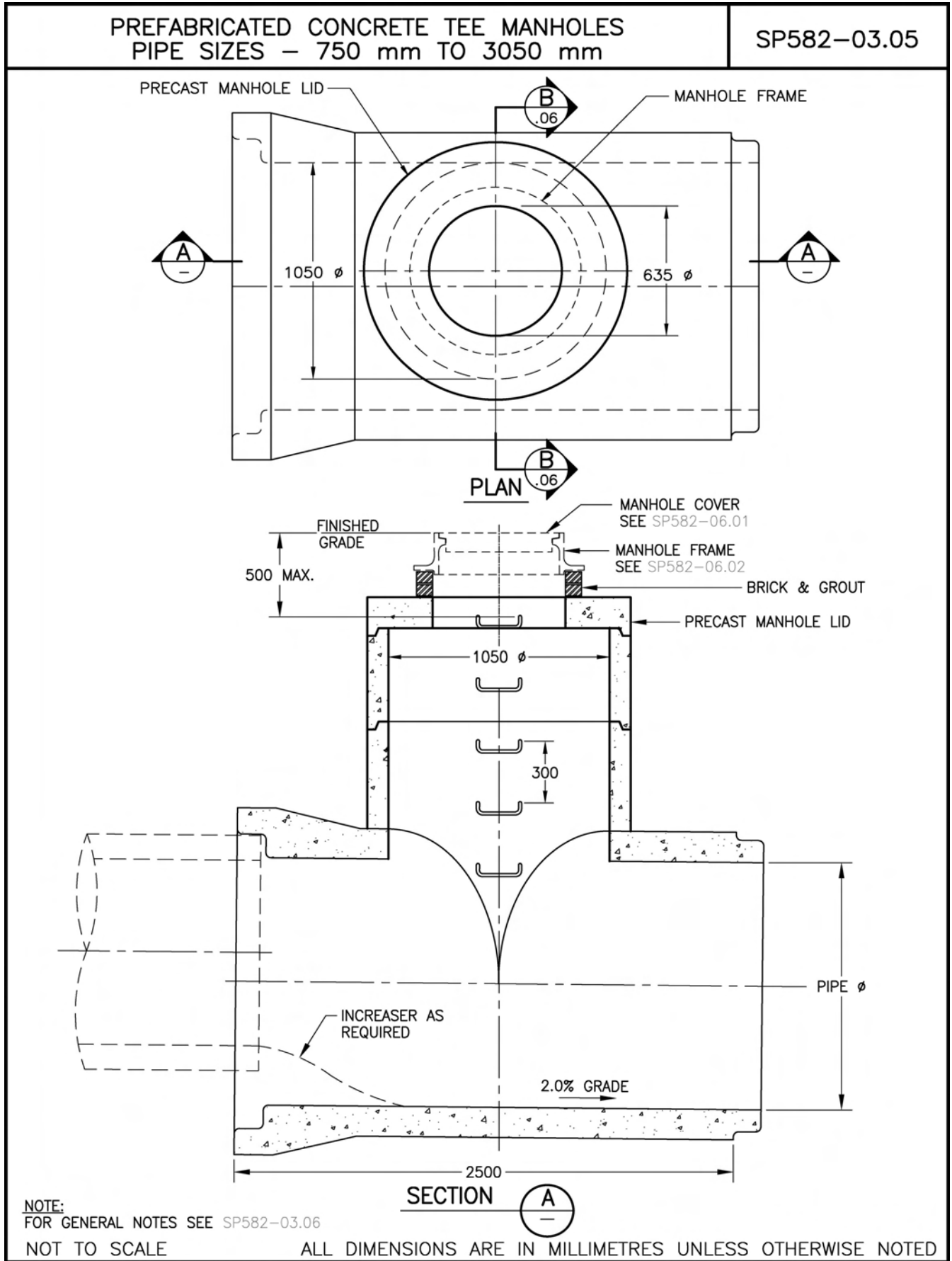

PREFABRICATED CONCRETE TEE MANHOLES
PIPE SIZES – 750 mm TO 3050

SP582-03.06

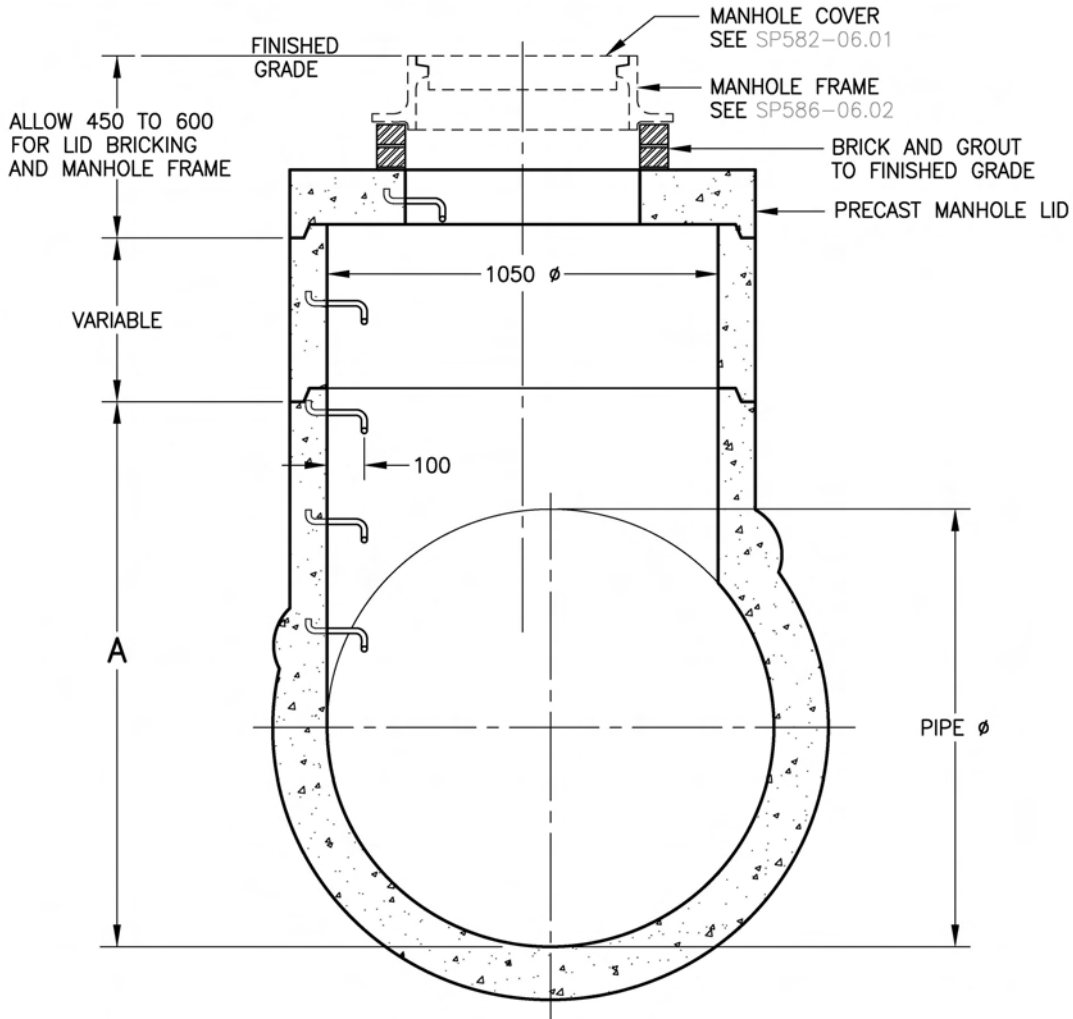

SECTION B
.05

NOTE: FOR LOCATION OF SECTION
SEE SP582-03.05

NOTE:

1. SUPPLIER TO INSTALL 19 ϕ GALVANIZED LADDER RUNGS OR PREAPPROVED ALTERNATIVE AS PER SUBSECTION 145.15.03
2. CONCRETE PIPE TO CONFORM TO ASTM C 76.
3. ALL PRECAST WORK TO CONFORM TO ASTM C 478 M.
4. MANHOLE LID TO WITHSTAND HS 20 LOADING.
5. MANHOLE TEE SECTION SHALL BE BEDDED AS PER SUBSECTION 582.37.
6. MANHOLE TEE SECTIONS MAY BE ORDERED AS INCREASERS ON THE UPSTREAM END TO ALLOW FOR PIPE SIZE CHANGES.

PIPE ϕ	A
750	1270
900	1400
1050	1550
1200	1720
1350	1880
1500	1970
1800	2210

NOT TO SCALE

ALL DIMENSIONS ARE IN MILLIMETRES UNLESS OTHERWISE NOTED

CORRUGATED STEEL MANHOLE MAIN SMALLER THAN RISER

SP582-03.07

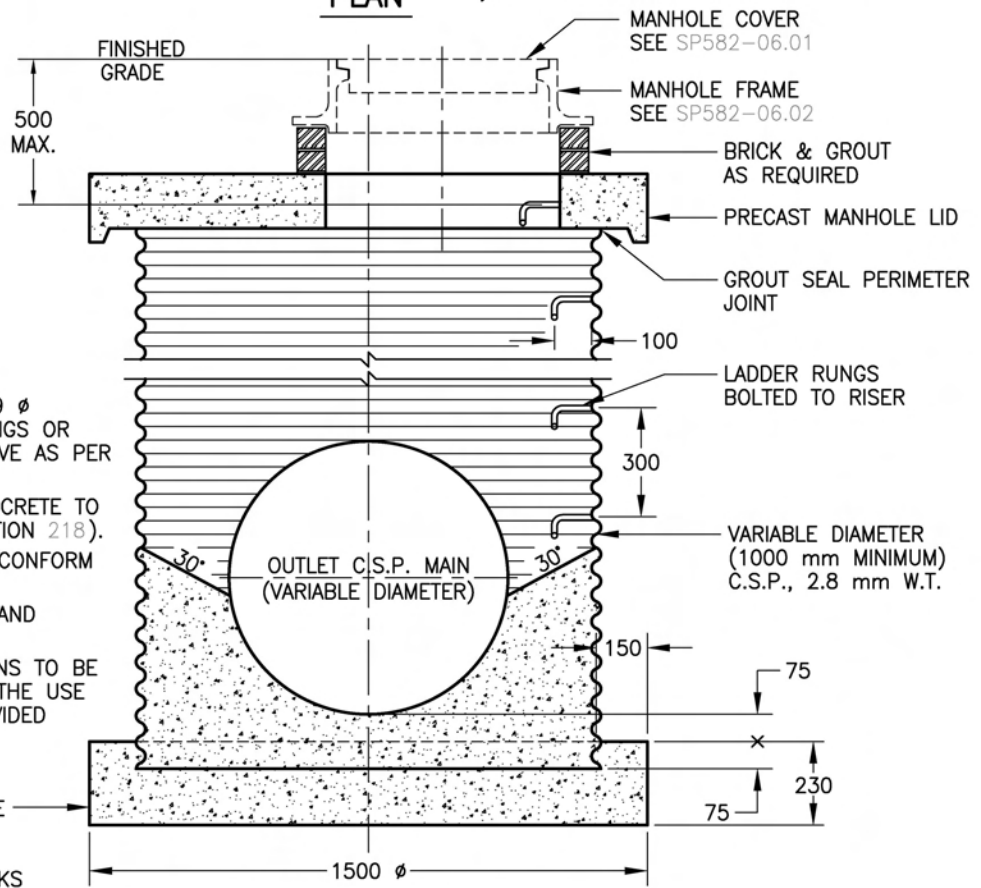
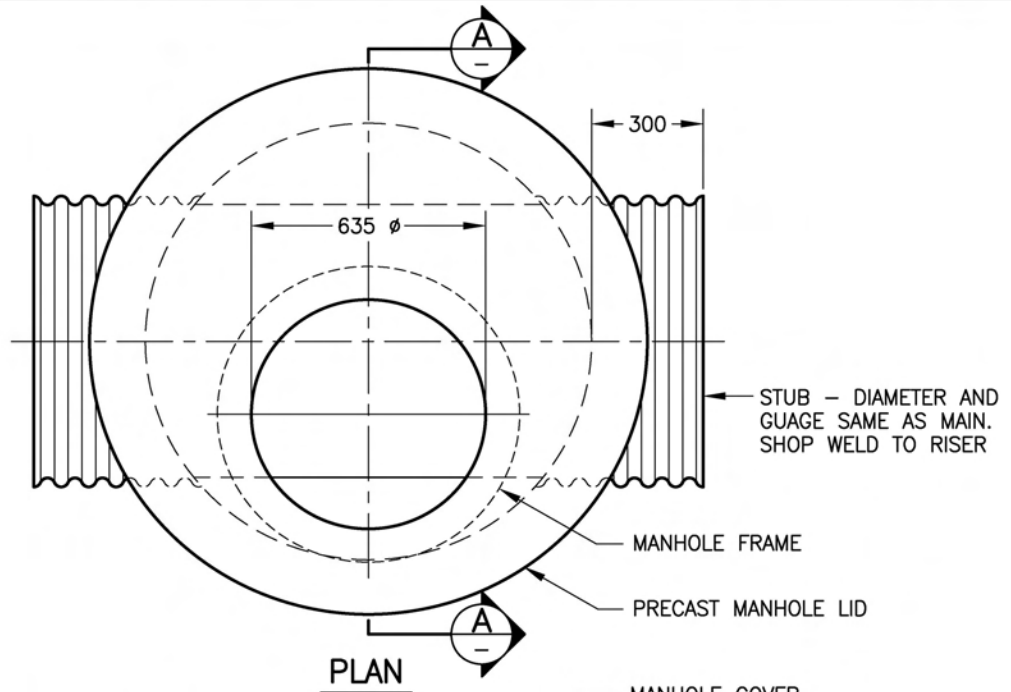

NOTES:

1. SUPPLIER TO INSTALL 19 ϕ GALVANIZED LADDER RUNGS OR PREAPPROVED ALTERNATIVE AS PER SUBSECTION 145.15.03
2. ALL CAST IN PLACE CONCRETE TO BE CLASS 'A' (SEE SECTION 218).
3. ALL PRECAST WORK TO CONFORM TO ASTM C 478 M.
4. MANHOLE LID TO WITHSTAND HS 20 LOADING.
5. ALL LATERAL CONNECTIONS TO BE MADE IN THE FIELD BY THE USE OF APPROPRIATELY PROVIDED SADDLES.

REINFORCED CONC. BASE TO BE POURED DURING THE INSTALLATION. USE BRICKS OR CONC. BLOCKS AS TEMPORARY SUPPORT FOR VERTICAL BARREL.

NOT TO SCALE

ALL DIMENSIONS ARE IN MILLIMETRES UNLESS OTHERWISE NOTED

CORRUGATED STEEL MANHOLE MAIN LARGER THAN RISER

SP582-03.08

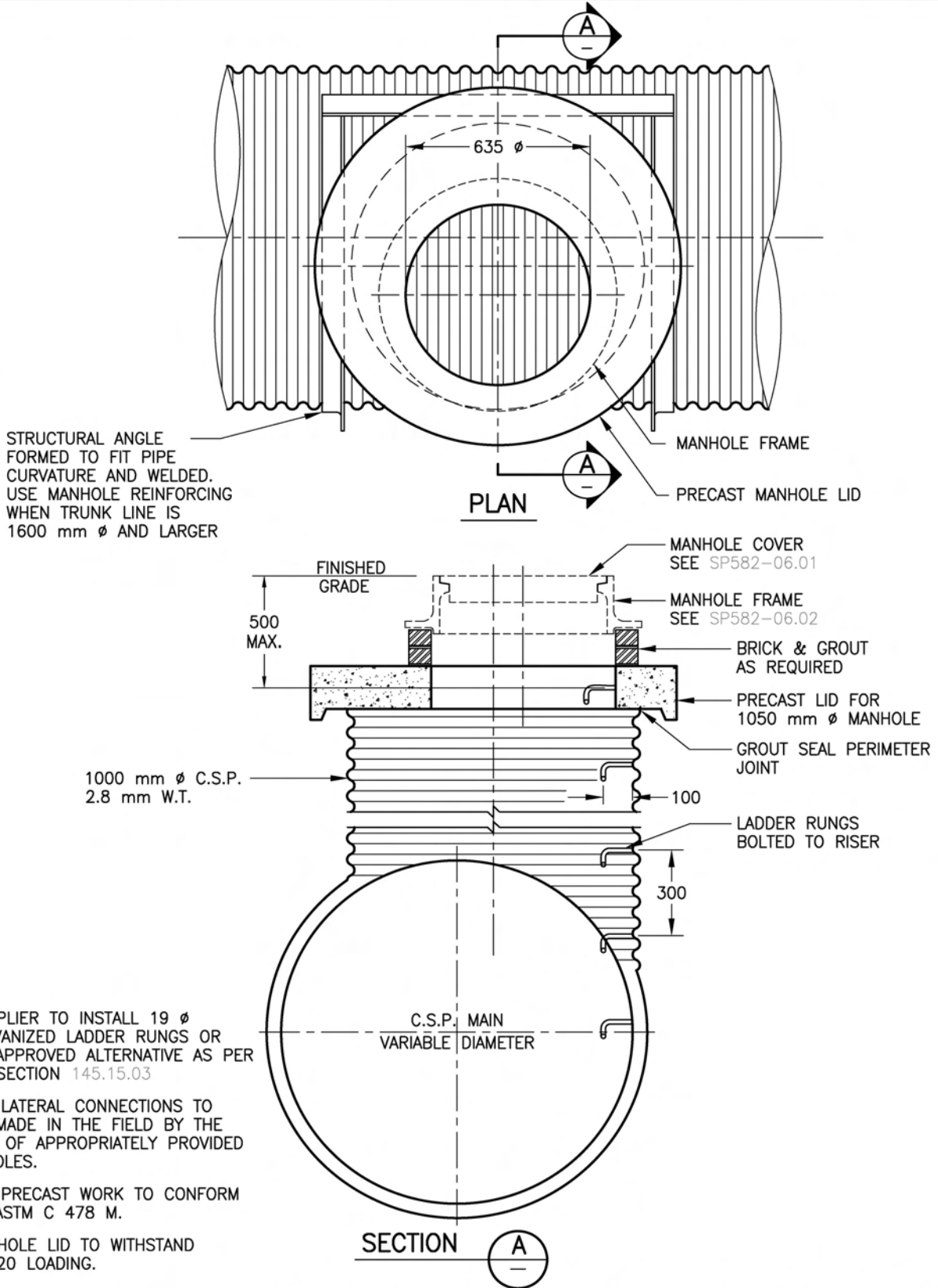

NOTES:

1. SUPPLIER TO INSTALL 19 ϕ GALVANIZED LADDER RUNGS OR PREAPPROVED ALTERNATIVE AS PER SUBSECTION 145.15.03
2. ALL LATERAL CONNECTIONS TO BE MADE IN THE FIELD BY THE USE OF APPROPRIATELY PROVIDED SADDLES.
3. ALL PRECAST WORK TO CONFORM TO ASTM C 478 M.
4. MANHOLE LID TO WITHSTAND HS 20 LOADING.

NOT TO SCALE

ALL DIMENSIONS ARE IN MILLIMETRES UNLESS OTHERWISE NOTED

CAST IN PLACE INLET STRUCTURE

SP582-04.01

WHEN DITCH BOTTOM IS WIDER THAN STRUCTURE, TRANSITION SLOPE SHALL BE PROTECTED WITH CONCRETE FILLED SAND BAGS

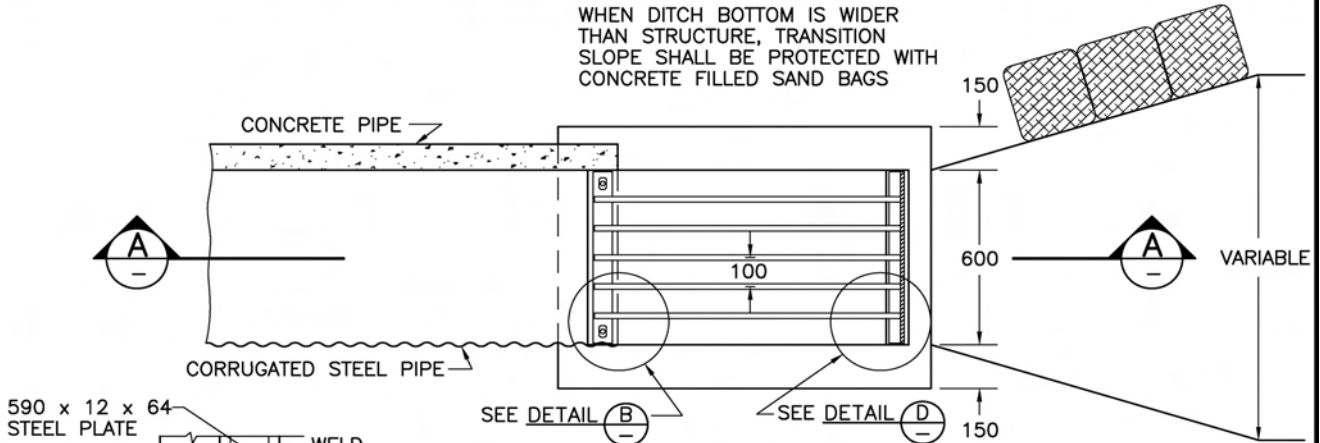

PLAN

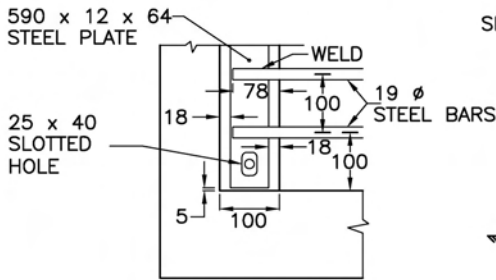

DETAIL B

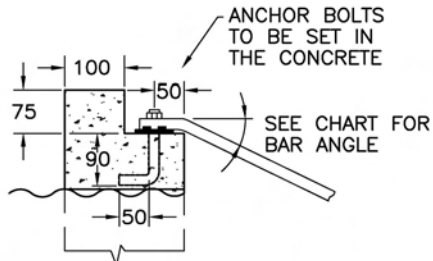

DETAIL C

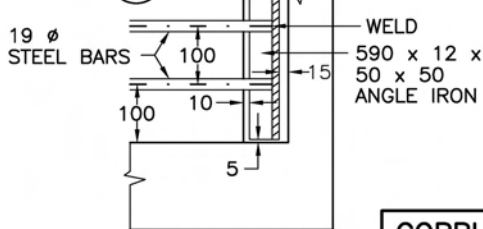

DETAIL D

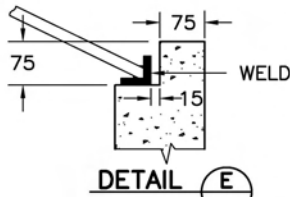

DETAIL E

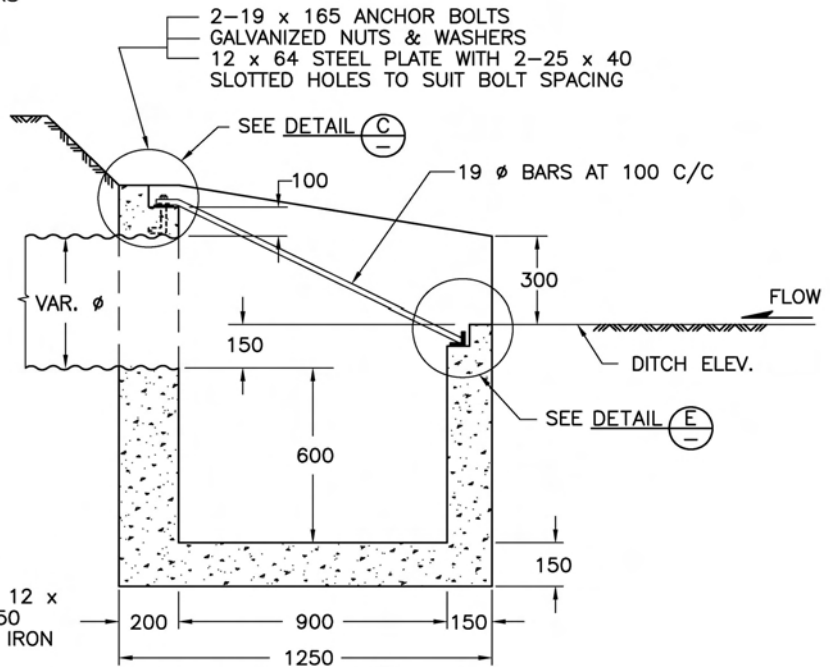

SECTION A

CORRUGATED STEEL PIPE		
PIPE DIAM.	BAR LENGTH	BAR ANGLE
300	1073	19°
400	1112	24°
500	1157	29°
600	1209	34°

CONCRETE PIPE		
PIPE DIAM.	BAR LENGTH	BAR ANGLE
300	1073	19°
375	1101	23°
450	1134	27°
525	1170	30°
600	1209	34°

NOTES:

1. ALL CONCRETE TO BE CLASS 'A' (SEE SECTION 218).
2. ALL STEELWORK TO CONFORM TO CSA SPECIFICATION CAN3-G40.21M GRADE 300W.
3. ALL STEELWORK TO BE GALVANIZED AFTER FABRICATION IN ACCORDANCE WITH CSA SPECIFICATION G164 TABLE 1.

NOT TO SCALE

ALL DIMENSIONS ARE IN MILLIMETRES UNLESS OTHERWISE NOTED

TYPE 'A' CATCH BASIN GRATE (FREEWAY GRATE)

SP582-05.01

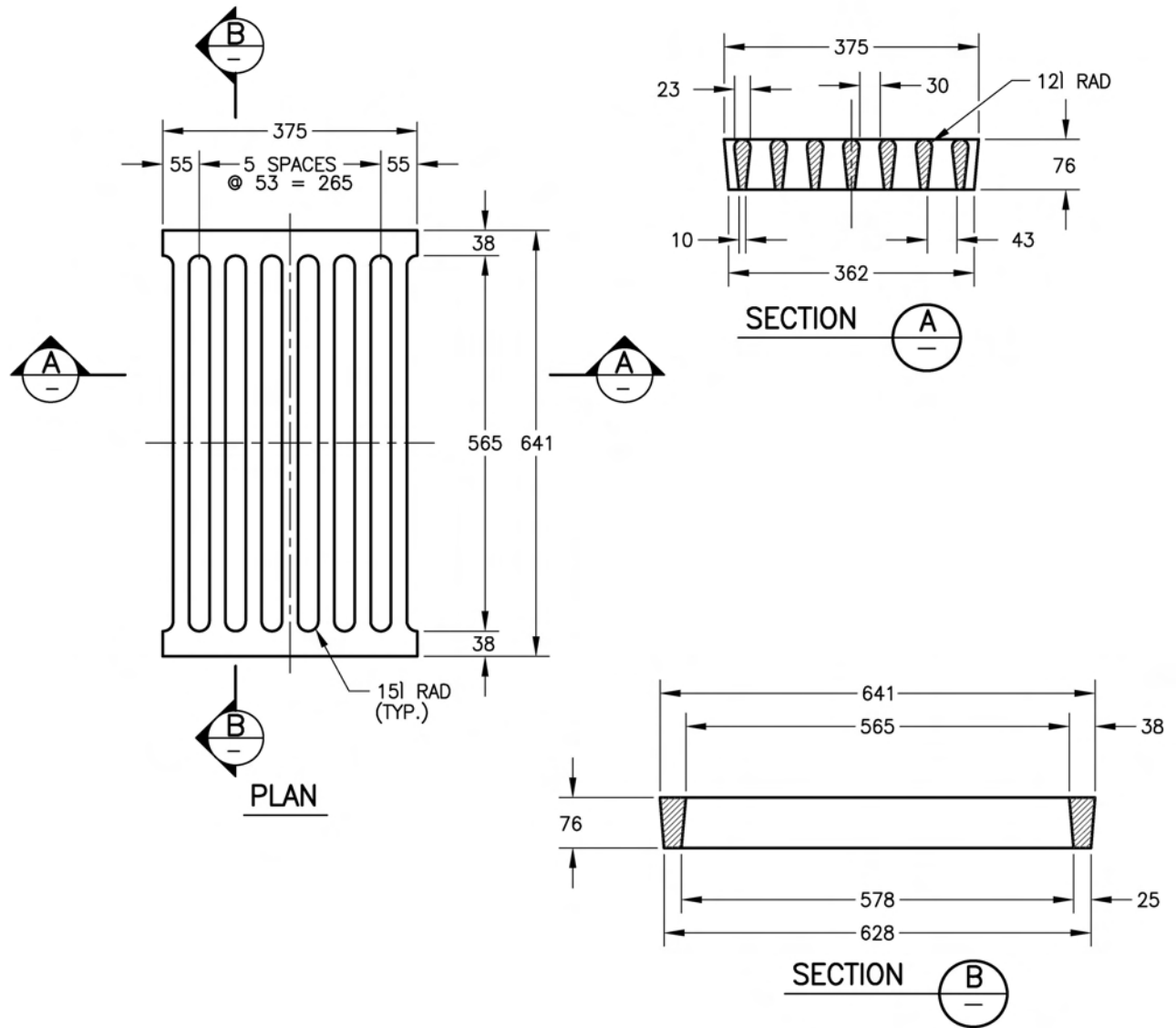

NOTE:

1. GRATES TO FIT CATCH BASIN FRAMES (SEE SP582-05.03 & SP582-05.04).
2. ALL MATERIAL TO BE CAST IRON.

NOT TO SCALE

ALL DIMENSIONS ARE IN MILLIMETRES UNLESS OTHERWISE NOTED

TYPE 'B' CATCH BASIN GRATE (BICYCLE SAFE GRATE)

SP582-05.02

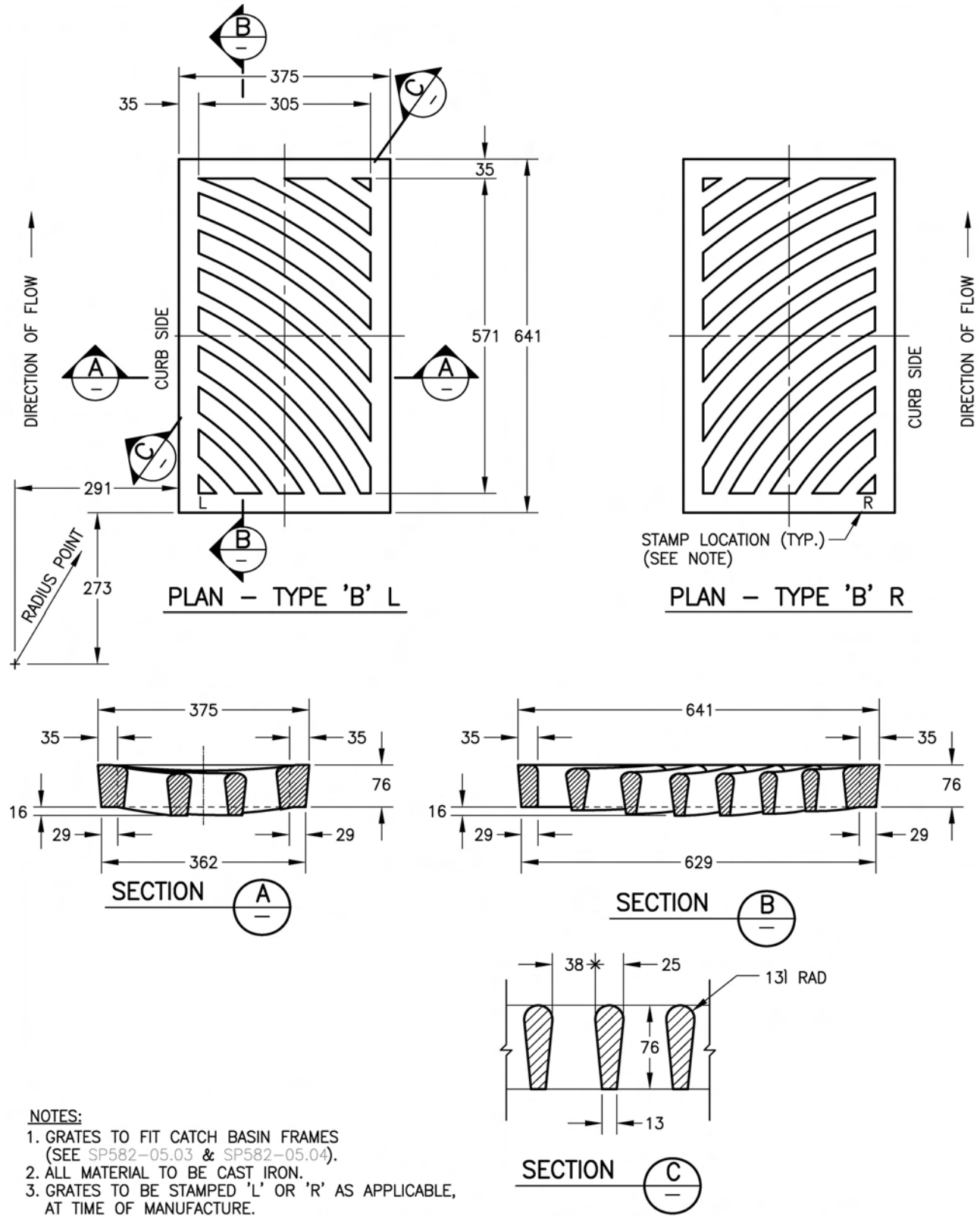

NOT TO SCALE

ALL DIMENSIONS ARE IN MILLIMETRES UNLESS OTHERWISE NOTED

SINGLE INLET CATCH BASIN FRAME

SP582-05.03

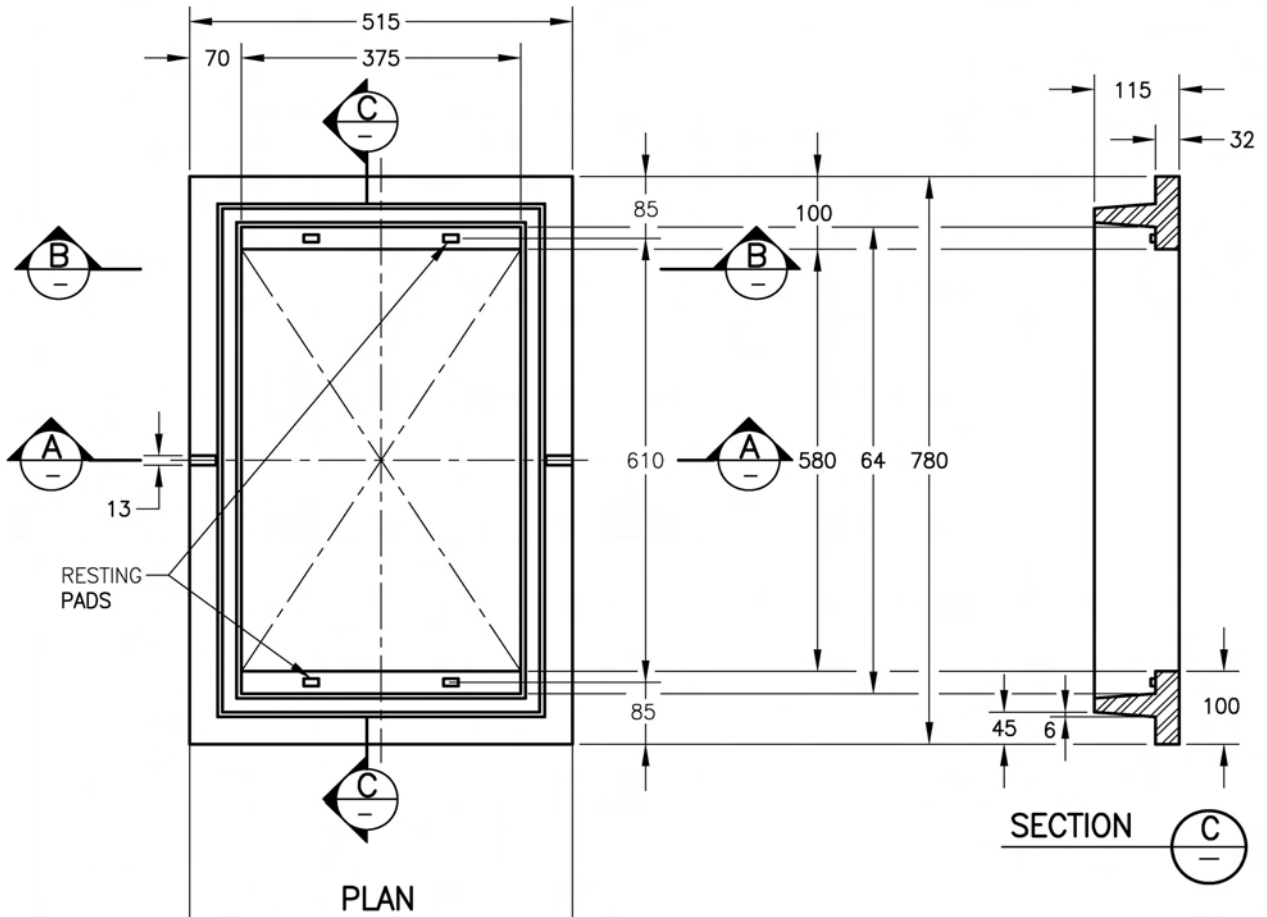

PLAN

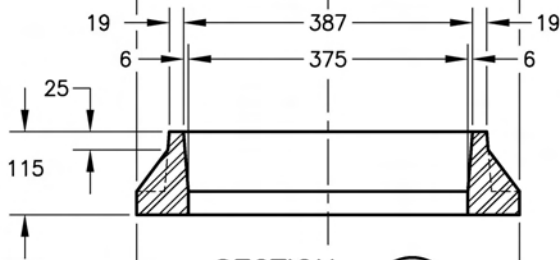

SECTION A

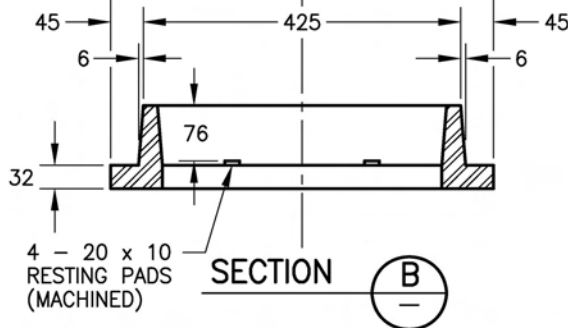

SECTION B

SECTION C

NOTES:

1. FRAME TO FIT CATCH BASIN GRATES (SEE SP582-05.01 & SP582-05.02).
2. ALL MATERIAL TO BE CAST IRON
3. CATCH BASIN FRAME TO BE USED WITH CATCH BASIN LID ACCESS OPENING 375 mm x 580 mm
4. FOR INSTALLATION SEE SP582-05.05

NOT TO SCALE

ALL DIMENSIONS ARE IN MILLIMETRES UNLESS OTHERWISE NOTED

TWIN INLET CATCH BASIN FRAME

SP582-05.04

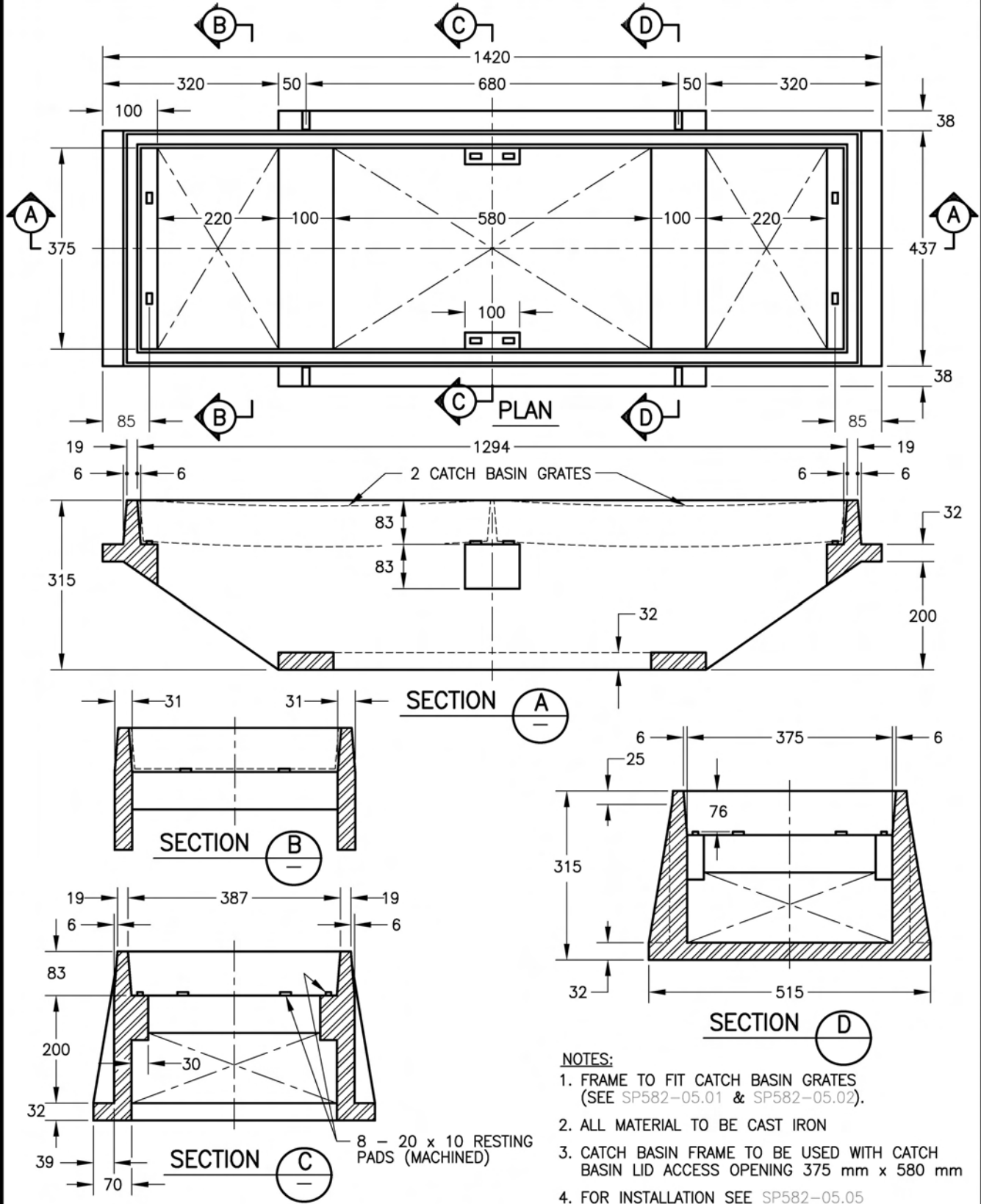

- NOTES:**
1. FRAME TO FIT CATCH BASIN GRATES (SEE SP582-05.01 & SP582-05.02).
 2. ALL MATERIAL TO BE CAST IRON
 3. CATCH BASIN FRAME TO BE USED WITH CATCH BASIN LID ACCESS OPENING 375 mm x 580 mm
 4. FOR INSTALLATION SEE SP582-05.05

NOT TO SCALE ALL DIMENSIONS ARE IN MILLIMETRES UNLESS OTHERWISE NOTED

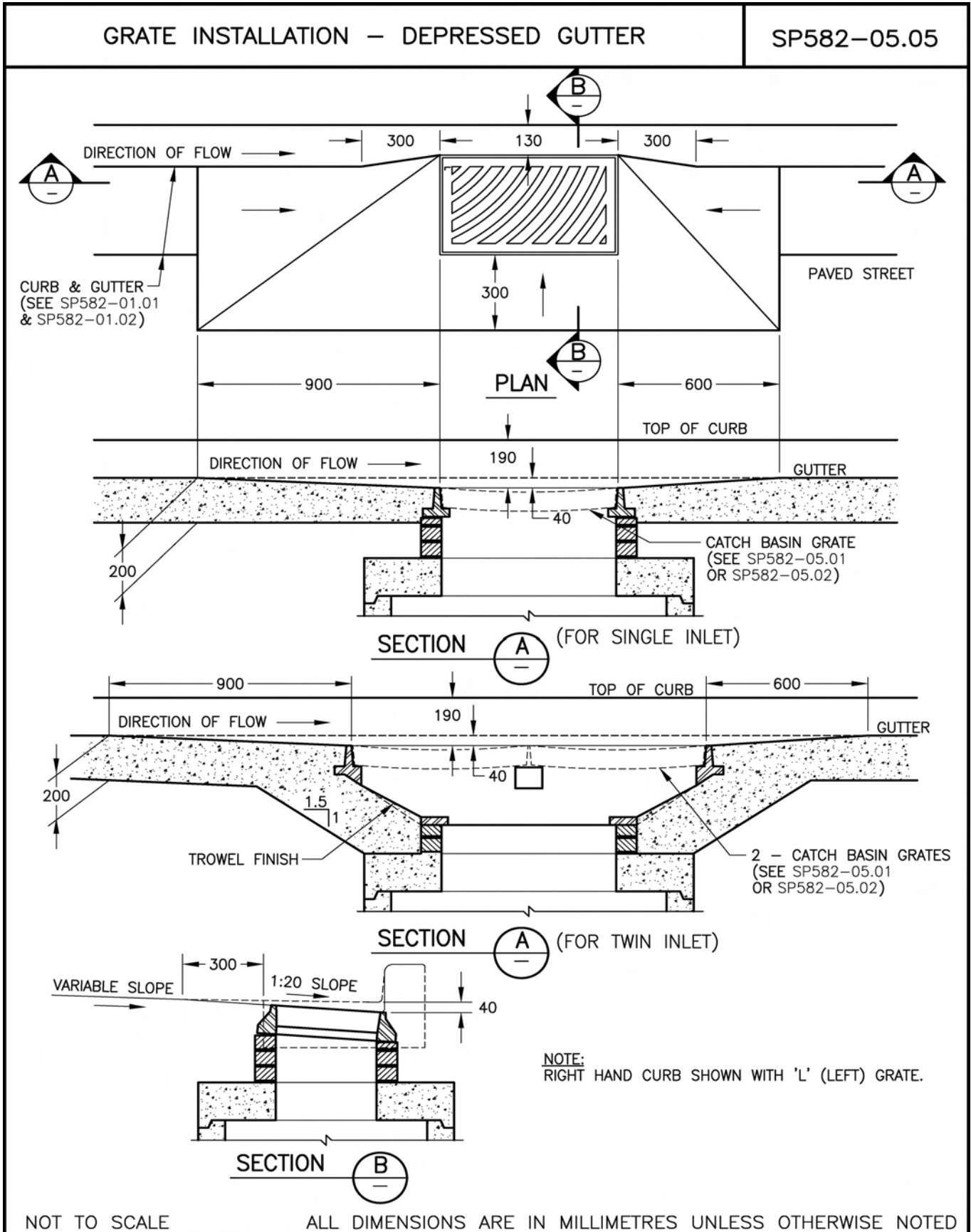

TRAPPING HOOD

SP582-05.06

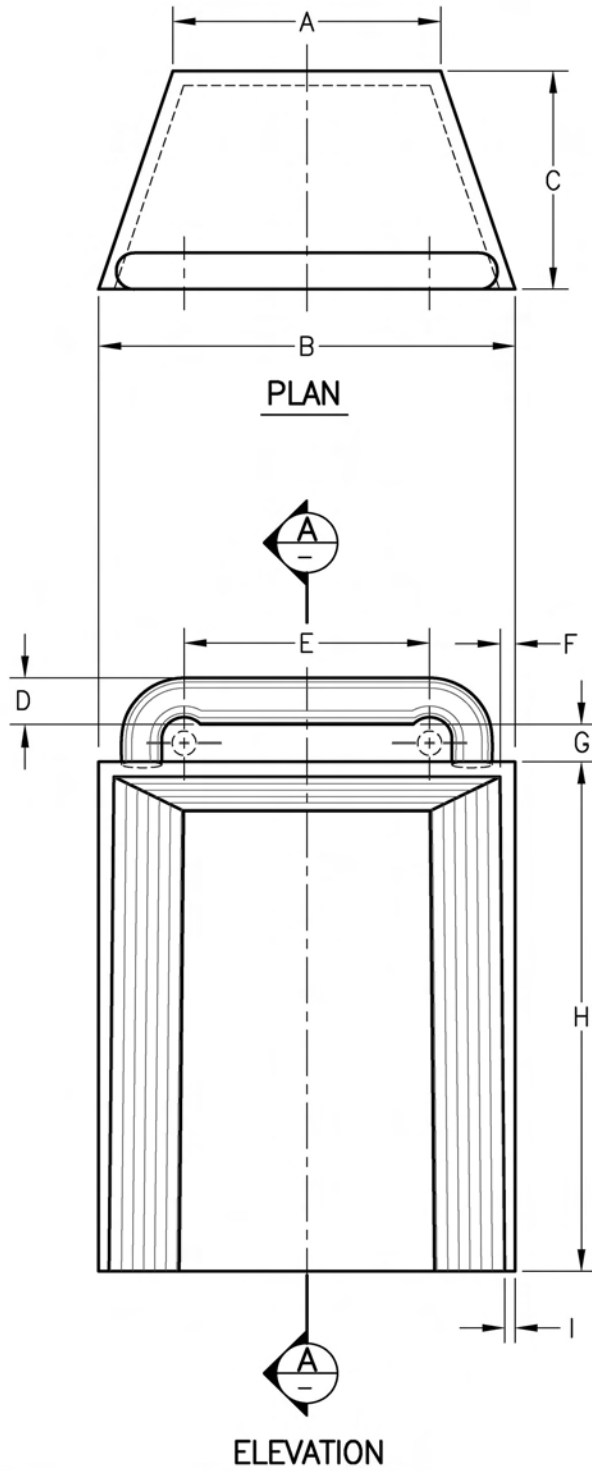

DIM.	1A 150 OUTLET	9 200 OUTLET	9A 300 OUTLET
A	180	215	320
B	280	345	445
C	150	215	255
D	32	32	38
E	165	190	305
F	10	13	13
G	25	25	25
H	350	425	535
I	7	10	10
J	25	29	29
K	325	370	470
MASS	16 kg	25 kg	49 kg

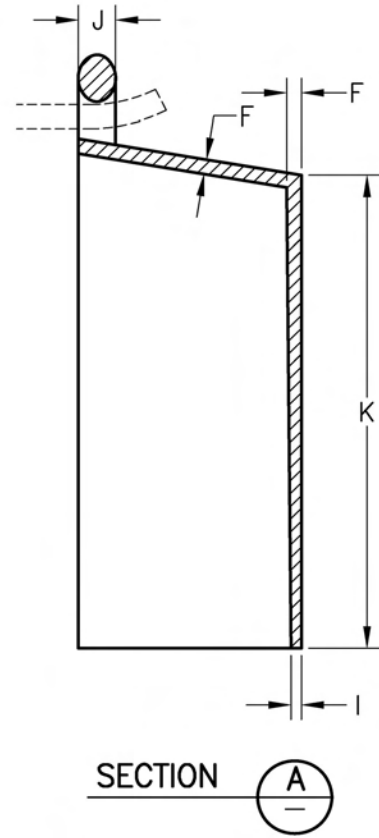

NOTE:
ALL MATERIAL TO BE CAST IRON.

NOT TO SCALE

ALL DIMENSIONS ARE IN MILLIMETRES UNLESS OTHERWISE NOTED

ASPHALT APRON

SP582-05.07

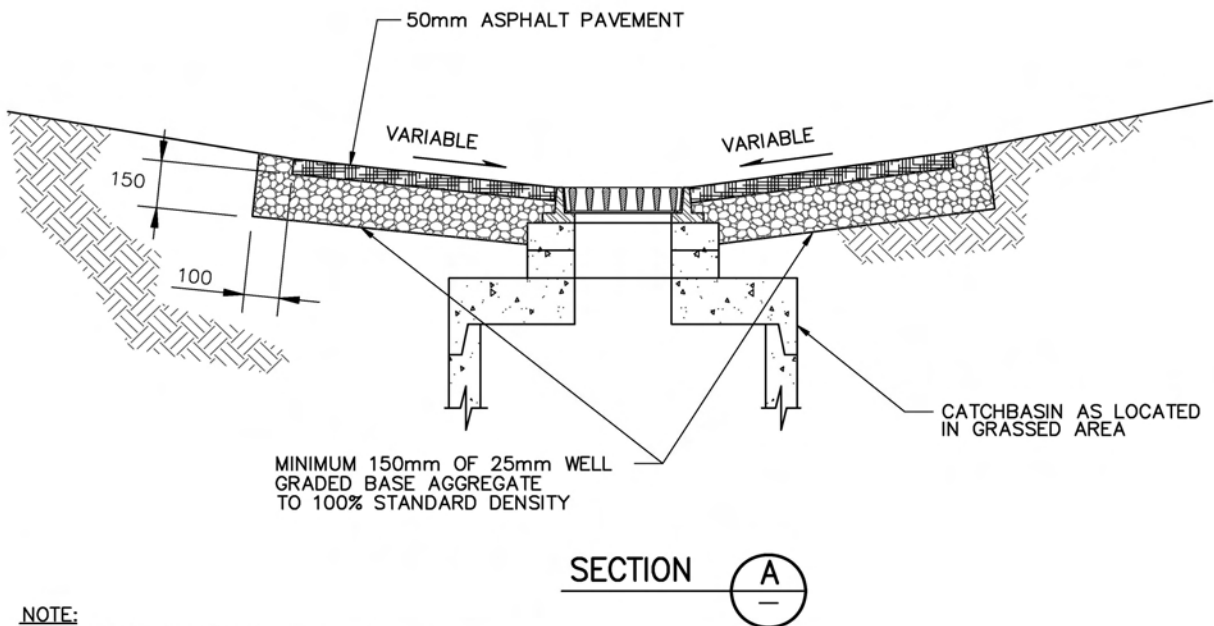
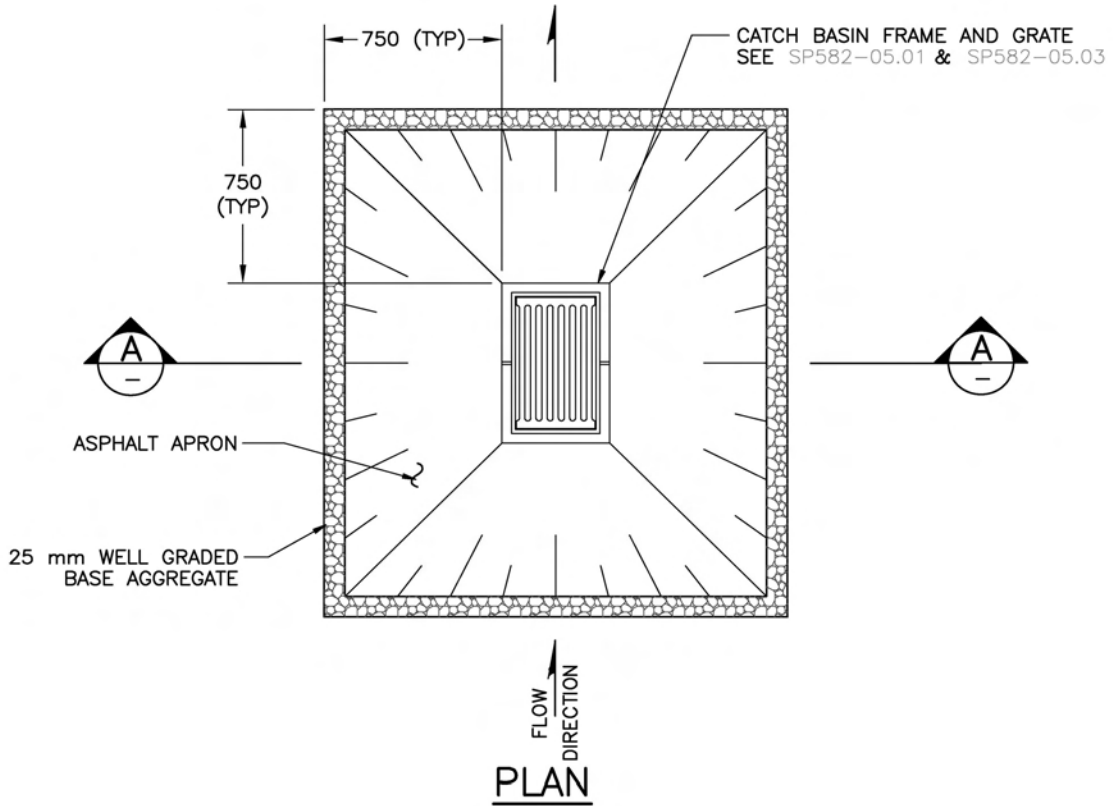

NOTE:
FOR DETAILS OF CATCH BASIN
SEE SP582-02.01 THROUGH SP582-02.05.

NOT TO SCALE

ALL DIMENSIONS ARE IN MILLIMETRES UNLESS OTHERWISE NOTED

MANHOLE COVER

SP582-06.01

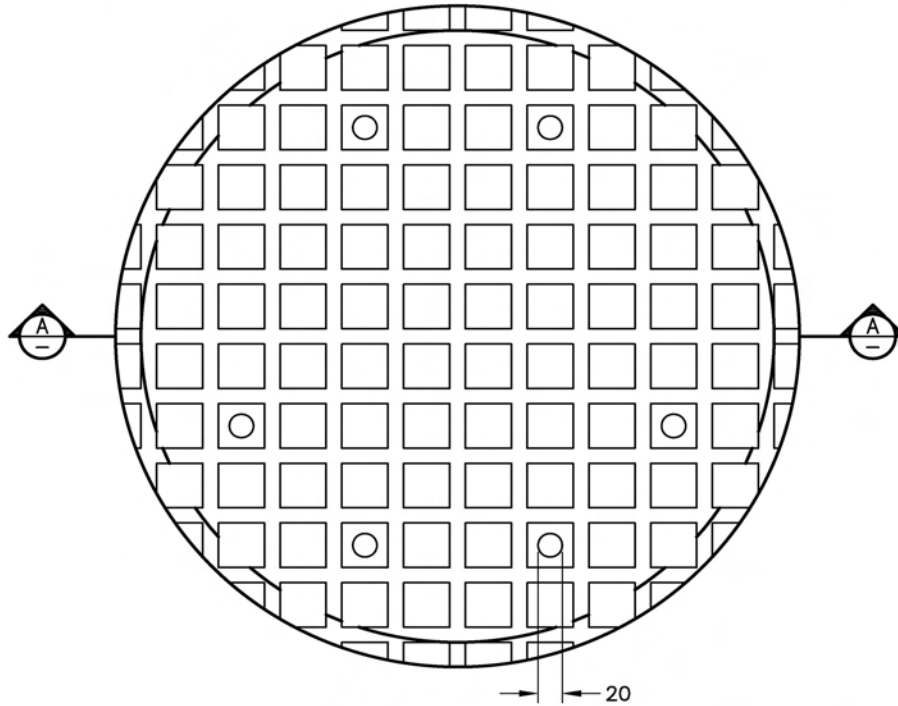

MATERIAL: CAST IRON

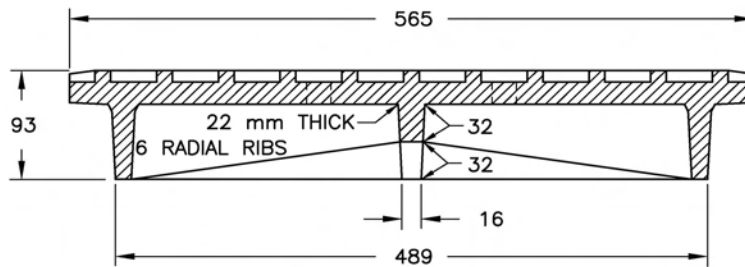

SECTION 

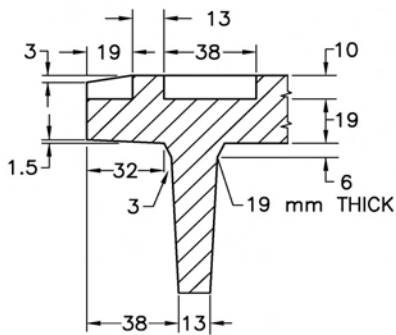

DETAIL OF RIM

NOTE: FOR FRAME SEE SP582-06.02

NOT TO SCALE

ALL DIMENSIONS ARE IN MILLIMETRES UNLESS OTHERWISE NOTED

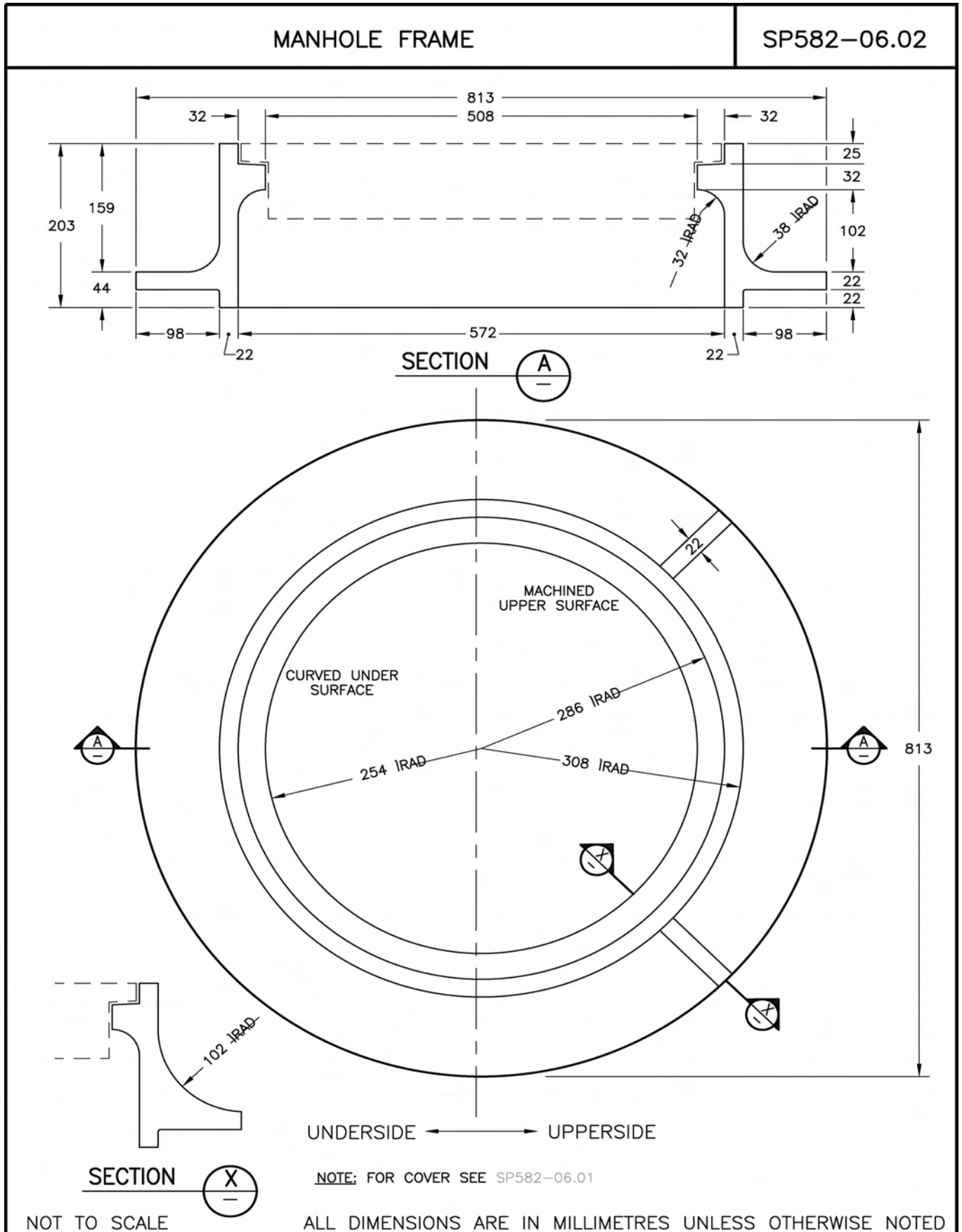

CONCRETE SIDEWALK & DRIVEWAY ENTRANCE

SP582-07.01

EXPANSION JOINTS

- AT 6 m INTERVALS ACROSS SIDEWALK.
- AROUND UTILITY POLES, CONCRETE STRUCTURES AND BUILDINGS.
- AT EACH END OF THICKENED SIDEWALK SECTION AND AT MID-SPAN WHEN THE LENGTH IS GREATER THAN 6 m.

DRIVEWAY WIDTHS

- COMMERCIAL 2 WAY TRAFFIC 7.5 - 15 m
- COMMERCIAL 1 WAY TRAFFIC 6 - 10 m
- RESIDENTIAL.....6 m

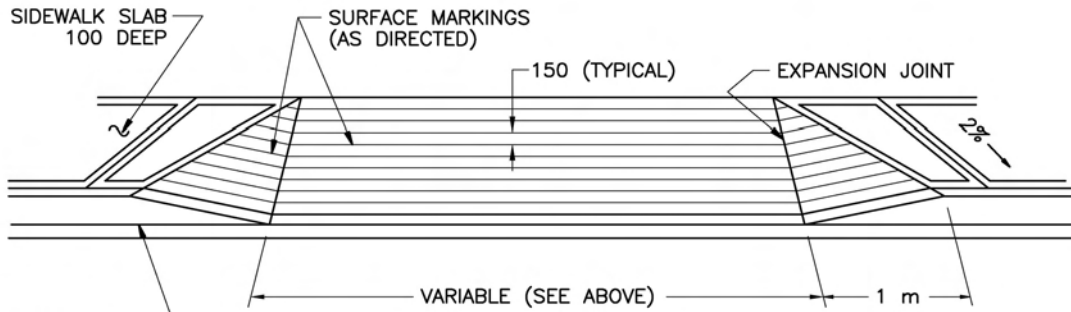
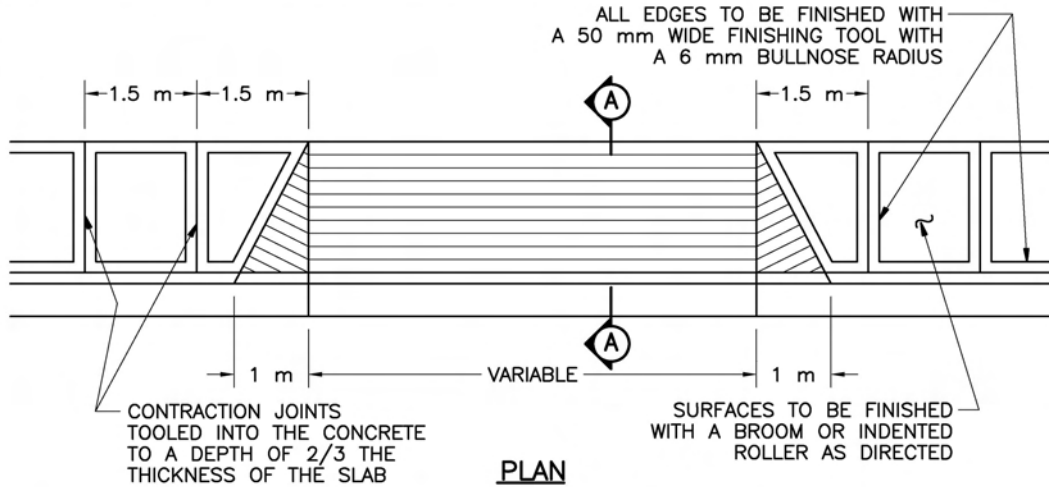

CURB AND GUTTER SEE SP582-01.01 & SP582-01.02

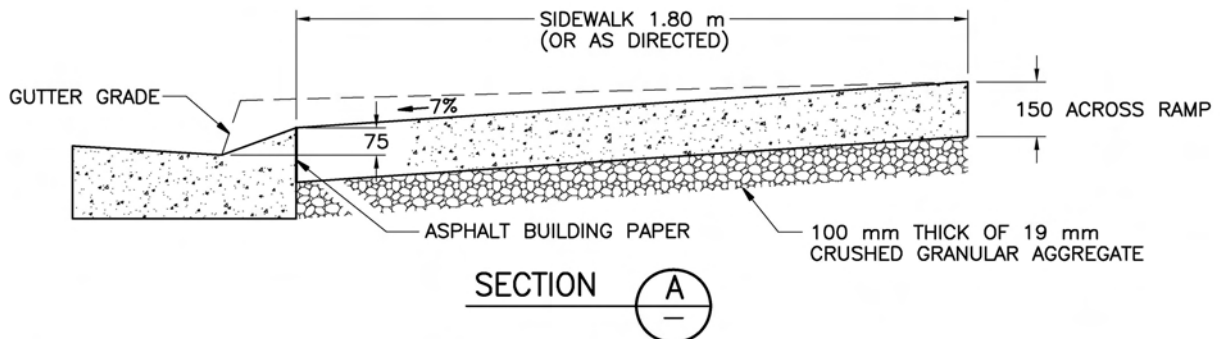

NOTES:

1. FOR OPEN SHOULDER DRIVEWAY DETAIL SEE B.C. SUPPLEMENT TO TAC.
2. ADD 150 mm TO WIDTH WHEN SIDEWALK FENCE IS REQUIRED.
3. ALL CONCRETE TO BE CLASS 'A' (SEE SECTION 218).

NOT TO SCALE

ALL DIMENSIONS ARE IN MILLIMETRES UNLESS OTHERWISE NOTED

SIDEWALK RAMP

SP582-07.02

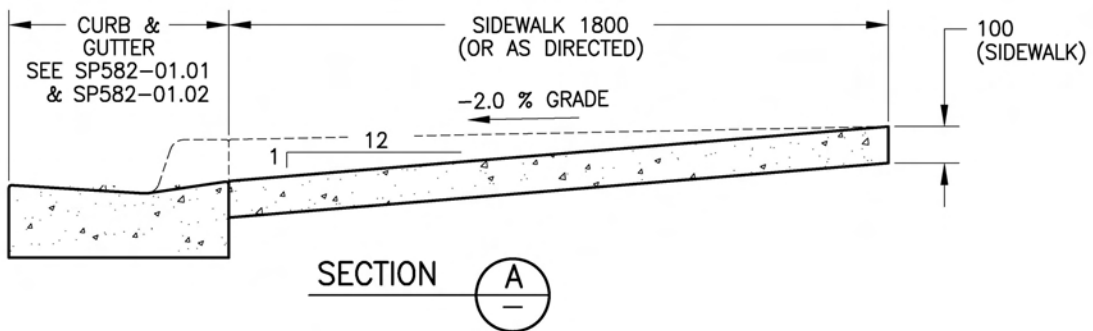
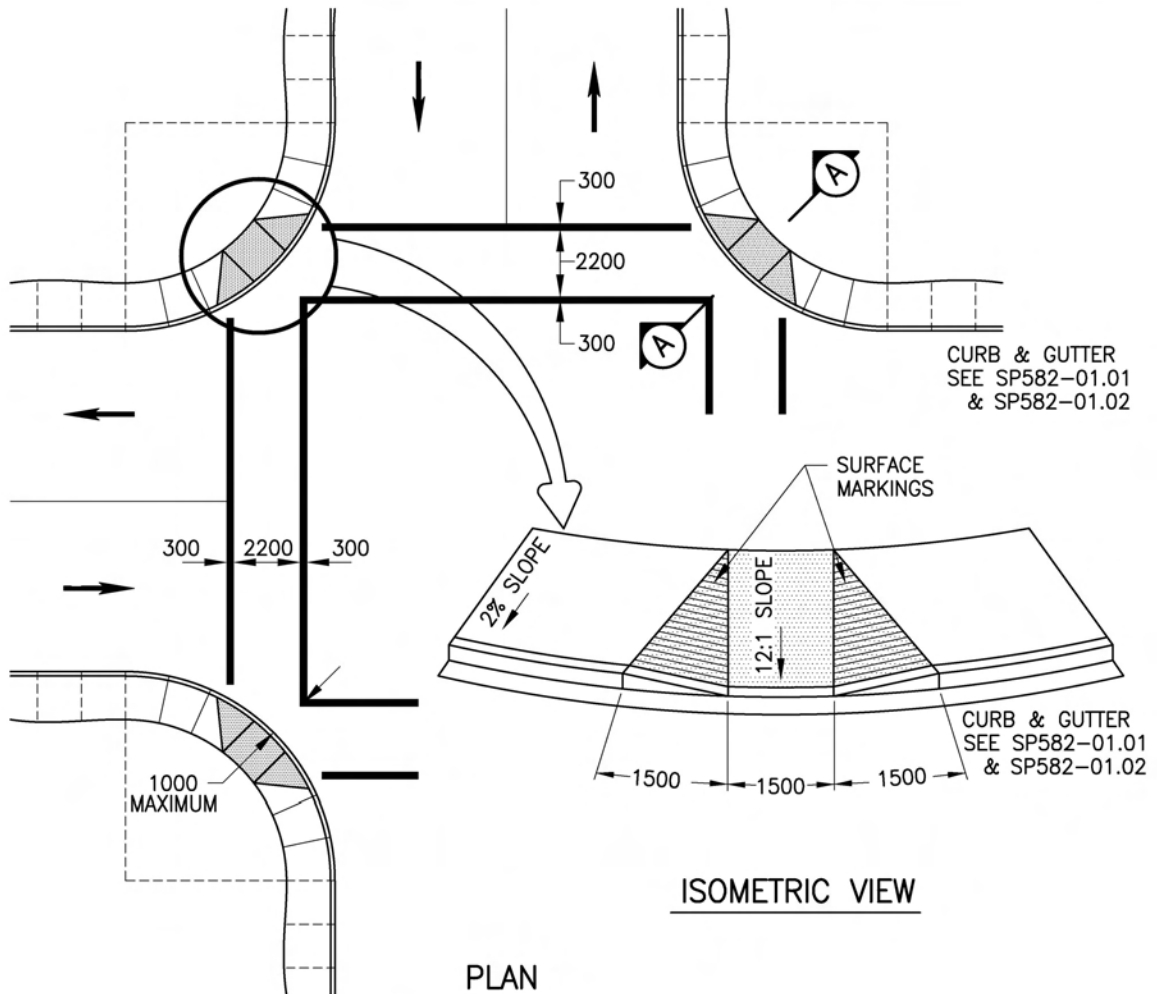

NOTE:

ALL CONCRETE TO BE CLASS 'A' (SEE SECTION 218).

NOT TO SCALE

ALL DIMENSIONS ARE IN MILLIMETRES UNLESS OTHERWISE NOTED

ISLAND RAMP

SP582-07.03

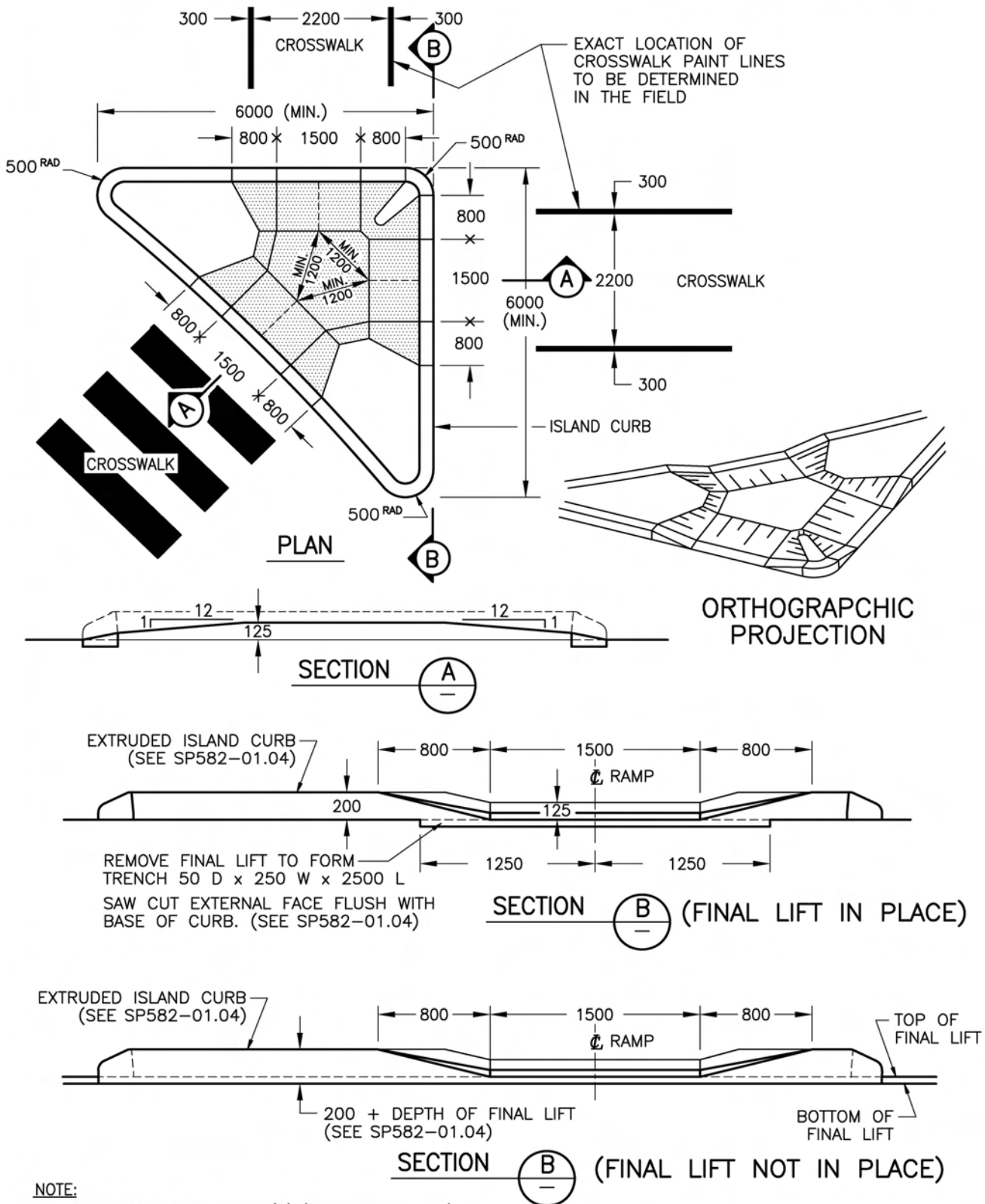

NOT TO SCALE

ALL DIMENSIONS ARE IN MILLIMETRES UNLESS OTHERWISE NOTED

REINFORCED CONCRETE STEPS

SP582-08.01

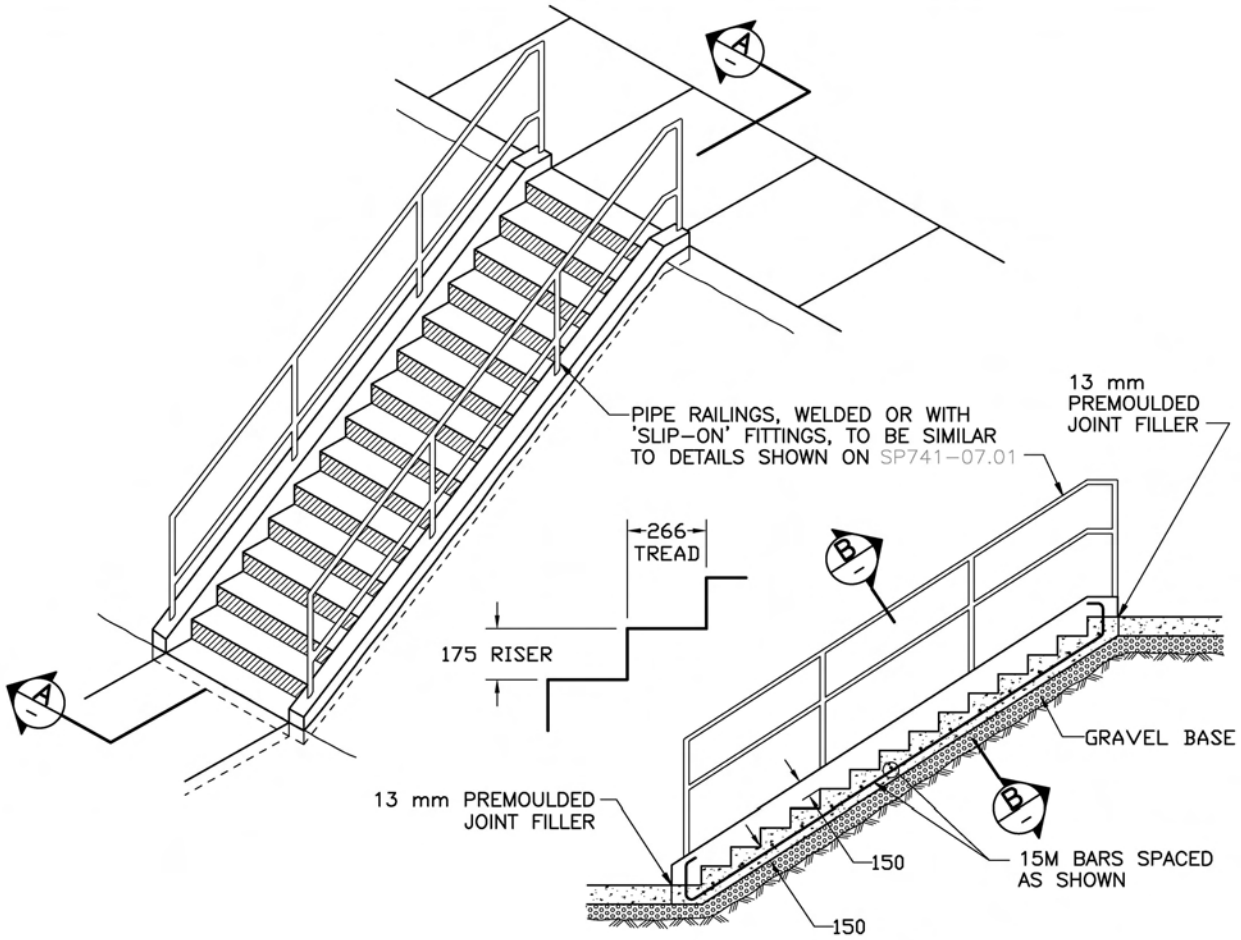

SECTION A

NOTES:

1. ALL CONCRETE TO BE CLASS 'A' (SEE SECTION 218).
2. REINFORCING STEEL TO CONFORM TO CSA SPECIFICATION G30.18-M GRADE 400.
3. ALL EXPOSED EDGES OF CONCRETE TO BE ROUNDED TO 13 mm RADIUS.

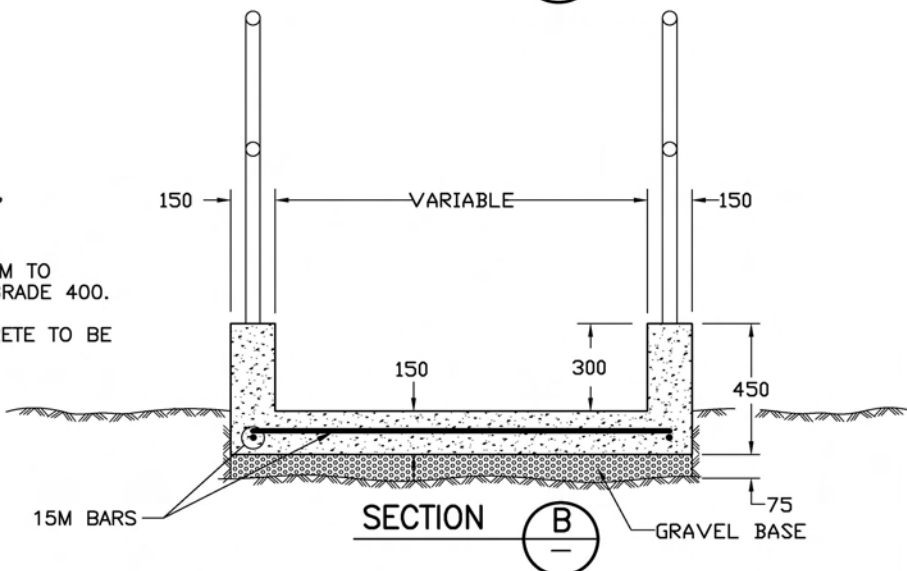

SECTION B

NOT TO SCALE

ALL DIMENSIONS ARE IN MILLIMETRES UNLESS OTHERWISE NOTED

THIS PAGE IS LEFT INTENTIONALLY BLANK

SECTION 586

PLANT MIXED PORTLAND CEMENT TREATED BASE COURSE

DESCRIPTION

586.01 Preliminary and General - This Specification describes the materials, plant equipment and quality of work required for the stabilization of base course material with Portland cement.

586.02 General Description of Work - The cement treated base shall consist of prepared aggregate, Portland cement and water uniformly mixed in the proportions directed, in a central mixing plant of satisfactory type, hauled out and laid on the prepared subgrade and compacted to established line and grade.

MATERIALS

586.11 Cement - Portland cement to be supplied for the work will comply with the requirements and tests of the Canadian Standards Association CAN 3-A5-M86 "Standard Portland Cements" and subsequent revisions thereof.

586.12 Water - The water shall be clean and free from substances deleterious to the hardening of the cement stabilized base course and shall be subject to the approval of the Ministry Representative.

586.13 Aggregate - The aggregate supplied shall be composed of inert durable material uniform in quality and free from organic impurities and soft or disintegrated particles. When tested according to ASTM C 136, the aggregate shall meet the gradation requirements listed in Table 586-A.

TABLE 586-A GRADATION REQUIREMENTS FOR AGGREGATE

SIEVE SIZE (mm)	PERCENT PASSING BY MASS
25	100
19	80 \pm 1000
9.5	50 \pm 100
4.75	35 \pm 70
2.36	25 \pm 50
1.18	15 \pm 35
0.300	5 \pm 20
0.075	0 \pm 5

The material shall have a liquid limit not greater than twenty-five and plasticity index not greater than six.

All aggregate shall be stockpiled in horizontal layers not

more than 1.0 m in thickness. The stockpile area shall be cleared of all vegetation, trees, brush, rock and other debris and a uniform ground surface prepared before the aggregate is deposited on the site. The material shall be loaded from the stockpile into the plant in such a manner as to ensure that a uniform cut of the pile is obtained. Mixing may not commence until a minimum of 30% of the total quantities of aggregate required is in the stockpile. Subsequent addition of prepared aggregate to the pile shall be so organized to ensure continued uniformity of the aggregate supply to the mixing plant.

EQUIPMENT

586.21 Mixing Plant - The Portland cement treated base course shall be mixed in a stationary plant employing either continuous or batch type equipment. The plant shall be equipped with interlocked feeding and metering devices which will add the cement, water and aggregates in proportions established by the Ministry Representative to a tolerance of \pm 3% by weight. The plant shall be capable of mixing the ingredients uniformly. Suitable storage shall be provided for bulk cement, and if required, bulk mineral filler. The capacity of the mixing plant shall be such that a minimum of 0.4 km of full width cement treated base can be laid per daily shift, i.e., sustained mixing capacity shall normally be not less than 250 tonnes per hour. Details of the plant and its operation shall be submitted to the Ministry Representative for approval prior to the commencing construction.

586.22 Cement Treated Base Spreader - The spreading device may be self-propelled, pushed or towed; and shall be so constructed and operated as to produce without segregation or surface tearing, a layer of material which is uniform in thickness and surface contour, either longitudinal or transverse, and free from irregularities in density. Whichever type of spreader may be used, it is mandatory that it be provided with a positive mechanical means for distributing the cement treated base transversely across the front of the cutoff mechanism or screed.

Spreading equipment which rides on the freshly spread material and produces tracks or partially compacted areas behind the cutoff blade will be acceptable provided no displacement of material or filling of the tracks occurs, and provided further that the tracks are not of such depth as to be visible after compaction is completed. The use of a motor grader or any other spreading device, which requires repeated trips over the same area, will not be permitted for spreading.

586.23 Water Distributors - Water distributors shall be the pressure type equipped with a spray bar mounting nozzles similar to those used on asphalt distributors and capable of applying the water in accurate quantities and as

a uniform spray. Splash plate type distributors or those equipped with spray bars that eject fine streams of water will not be permitted. The distributor must be provided with a satisfactory accurate means of measuring the quantity of water sprayed.

CONSTRUCTION

586.31 Mixing - The mix proportions shall be determined by the Ministry Representative from samples taken at the commencement of aggregate production. The approximate estimated mix proportions of aggregate, cement, filler and water will be indicated in the Special Provisions if adequate advance information is available.

The aggregate, mineral filler and cement shall be fed into the pugmill accurately, according to the proportions required, and shall be thoroughly dry mixed. Water shall then be added in the required amount and mixing continued until uniformity is achieved.

586.32 Spreading and Compaction

586.32.01 Surface - The surface of the subgrade shall be thoroughly moistened just prior to placing the cement treated base mixture thereon and shall be kept moist but not excessively wet until covered by the mixture.

586.32.02 Cement Treated Base Mixture - The cement treated base mixture shall be hauled to the roadbed in trucks equipped with protective covers and shall then be laid through a Titan ABG paver or equivalent in a manner to produce a layer of uniform density and cross-section and in sufficient quantity to provide a compacted base conforming to the grade and cross-section set by the Ministry Representative. End dumping on the roadway followed by spreading will not be permitted. Depositing and spreading the material on the roadway shall progress continuously without breaks, except as otherwise directed by the Ministry Representative. At the end of each day's full width construction, a straight transverse construction joint shall be formed by cutting back into the completed work to form a true vertical face and by installing a temporary wooden header, if required by the Ministry Representative.

586.32.03 Compaction - Immediately following spreading, the material shall be compacted to a minimum 100% of the laboratory density obtained by the current ASTM test method D 698.

586.32.04 Compaction Equipment - While the Contractor may be given considerable discretion to select the method of compaction to be employed subject to the approval of the Ministry Representative, the compaction equipment to be used may include at least one three-wheeled tandem self-propelled steel wheel roller, able to exert a minimum pressure of 60 kg/cm per cm width of roller. In addition, the Contractor must be prepared to supply a minimum of one vibratory compaction unit, either steel wheel roller or multiple plate

type, if so required by the Ministry Representative. The use of compacting equipment which marks, ruts, cracks or otherwise loosens or damages the surface of the cement treated base will not be permitted. The compacting equipment shall have sufficient capacity to produce the specified degree of compaction within the time limits specified.

Wherever compaction planes are formed in the cement treated base during spreading, shaping or compaction, they shall be removed by scarifying or tilling the surface to such depth as directed by the Ministry Representative and in such a manner as to thoroughly break up the compaction planes. Scarifying and pulverization may be performed by any suitable equipment - nail drag, weeder, disk harrow or rotary tiller that will satisfactorily perform the work required. The scarified material will be regraded and recompacted, to the satisfaction of the Ministry Representative.

586.32.05 Water - Water shall be applied at the rates and in the quantities directed by the Ministry Representative. The surface of the uncompacted, partially compacted and completely compacted material shall be kept moist at all times. An adequate water supply shall be maintained at the point of compacting.

586.32.06 Speed - The speed of operations shall be such that not more than forty-five minutes shall elapse between the time of starting mixing and the time of starting compaction. Shaping and final compaction shall be completed within two hours of commencement of mixing at the plant.

586.32.07 Finished Surface - The finished surface of the compacted base shall at all points be accurate to ± 15 mm of the grade and shall not, at any point, deviate by more than 10 mm from the bottom of a 3 m straight edge laid in any direction on the surface on either side of the crown of the roadway.

586.32.08 Temperature - No construction shall be undertaken when the temperature is below 4.0°C or when the conditions indicate that the temperature will fall below 4.0°C in the next 24 hours or if the subgrade is frozen.

586.33 Protection and Cover

586.33.01 General - Protection and cover shall be provided by one of the methods, A or B, given below and as directed in the Special Provisions.

a) **Method A - Crushed Gravel Course** - 25 mm crushed gravel shall be laid not more than 24 hours after the treated base is laid. The surface of the treated base and the overlying gravel shall be kept moist by the application of water as directed by the Ministry Representative.

b) **Method B - Bituminous Seal** - As soon as possible after the cement treated base course has been finished, in accordance with preceding subsections, a bituminous seal shall be applied to the surface and sanded to protect the

cement treated base course from drying out during the seven day curing period. The finished base course shall be kept continuously moist until the seal has been applied.

The bituminous sealing material shall be applied at a rate between 0.7 to 1.0 /m² or as directed by the Ministry Representative in order to give complete surface coverage without excessive runoff.

Generally, this work shall be governed by the applicable provisions of SS 502.21 "Spray Primer and Tack Coat". At the time of sealing, the surface of the cement treated base must be dense, free from all loose and extraneous material and shall contain sufficient moisture to prevent penetration of the bituminous material. If needed, water shall be applied in sufficient quantity to fill the surface voids of the soil cement immediately before the bituminous material is applied. The seal cover shall be effectively maintained by the Contractor during the seven day curing period.

586.33.02 Protection - Any finished portion of the base course adjacent to construction, which is travelled by equipment used in constructing an adjoining section, shall be protected in such a manner as to prevent equipment from marring or damaging the completed work.

586.33.03 Temperature - At any time when the air temperature may be expected to fall to the freezing point, during the day or the night, sufficient above protection shall be given to the cement treated base to prevent its freezing for seven days after placement and until the soil cement has hardened.

586.34 Maintenance - The Contractor shall maintain the entire base course in good condition satisfactory to the Ministry Representative from commencement of construction until it has been paved with asphalt concrete. Maintenance shall include immediate repairs to any

defects that may occur and shall be repeated at the Contractor's expense as often as may be necessary to keep the section continuously intact.

MEASUREMENT

586.81 Cement Treated Base - Cement treated base in place will be measured by the TONNE for the total mass actually accepted and incorporated in the base of the road.

586.82 Water - Water applied to the road will be measured by the THOUSAND LITRES for the actual quantity applied to the road.

PAYMENT

586.91 Cement Treated Base - Payment for CEMENT TREATED BASE will be at the Contract Unit Price per tonne for the total mass actually accepted and incorporated in the base of the road. Payment shall provide full compensation for production of aggregate; handling, hauling and storage of bulk cement and filler; provision of mixing water and plant mixing of cement treated base; haulage, spreading, grading and compaction of the base material in place; and for all labour, equipment, plant, tools, superintendence, traffic control and all other incidentals necessary to complete the work in accordance with the specifications.

586.92 Water - Payment for WATER will be at the Contract Unit Price per thousand litres for the actual quantity applied to the road, as directed, and shall be full compensation for furnishing all labour, materials, tools and equipment required, and doing all the work incidental to furnishing, hauling and applying water to the road as specified.

THIS PAGE IS LEFT INTENTIONALLY BLANK