

CHAPTER C

ALIGNMENT

CHAPTER C ALIGNMENT

| | | |
|------------|---|-------------|
| C.1 | INTRODUCTION | C1-1 |
| | C.1.1 DEFINITIONS | C1-1 |
| | C.1.2 COMPONENTS | C1-1 |
| | C.1.3 CONTROLS | C1-1 |
| | C.1.4 DESIGN CONSIDERATIONS | C1-1 |
| | C.1.5 GEOMETRY | C1-2 |
| | | |
| C.2 | SIGHT DISTANCE | C2-1 |
| | C.2.1 POLICY | C2-1 |
| | C.2.2 DEFINITIONS | C2-1 |
| | C.2.3 STOPPING SIGHT DISTANCE | C2-1 |
| | C.2.3.1 Assumed Speed for Design | C2-1 |
| | C.2.3.2 Perception and Brake Reaction Time | C2-1 |
| | C.2.3.3 Braking Distance | C2-2 |
| | C.2.3.4 Design Values | C2-2 |
| | C.2.3.5 Adjustments for Grade | C2-2 |
| | | |
| | C.2.4 PASSING SIGHT DISTANCE | C2-4 |
| | C.2.4.1 Criteria for Design | C2-4 |
| | C.2.4.2 Design Values | C2-5 |
| | | |
| | C.2.5 INTERSECTION SIGHT DISTANCE | C2-5 |
| | | |
| C.3 | HORIZONTAL ALIGNMENT | C3-1 |
| | C.3.1 COMPONENTS | C3-1 |
| | C.3.2 CIRCULAR CURVES | C3-1 |
| | C.3.2.1 Introduction | C3-1 |
| | C.3.2.2 Speed-Radius Relationship | C3-1 |
| | C.3.2.3 Maximum Superelevation | C3-1 |
| | C.3.2.4 Lateral Friction | C3-1 |
| | C.3.2.5 Minimum Radii | C3-3 |
| | C.3.2.6 Distribution of Superelevation | C3-3 |
| | C.3.2.7 Superelevation Transition and Tangent Runout | C3-3 |
| | C.3.2.8 Cross-fall and Superelevation for Resurfacing Projects | C3-3 |
| | | |
| | C.3.3 SPIRAL CURVES | C3-4 |
| | C.3.3.1 Function | C3-4 |
| | C.3.3.2 Form and Properties | C3-4 |
| | C.3.3.3 Designation | C3-4 |
| | C.3.3.4 Basis of Design | C3-4 |
| | C.3.3.5 Design Values | C3-5 |
| | C.3.3.6 Superelevation and Tangent Runout | C3-5 |

CHAPTER C

ALIGNMENT

| | | |
|--------------|--|--------------|
| C.3.4 | DESIGN CONTROLS | C3-13 |
| C.3.4.1 | Sight Distance | C3-13 |
| C.3.4.2 | Minimum Curve Length | C3-13 |
| C.3.4.3 | Intersections | C3-13 |
| C.3.4.4 | Railway Crossings | C3-13 |
| C.3.4.5 | Deviation from Standards | C3-13 |
| | | |
| C.3.5 | DESIGN PRINCIPLES AND APPLICATION | C3-15 |
| C.3.5.1 | Spiraled Circular Curves | C3-15 |
| C.3.5.2 | Segmental Spiral Curves | C3-15 |
| C.3.5.3 | Compound Circular Curves | C3-15 |
| C.3.5.4 | Spiral Curves Only | C3-15 |
| C.3.5.5 | Reverse Spiral Curve (Back to Back) | C3-15 |
| C.3.5.6 | Integration of Design Features | C3-15 |
| | | |
| C.4 | VERTICAL ALIGNMENT | C4-1 |
| | | |
| C.4.1 | COMPONENTS | C4-1 |
| | | |
| C.4.2 | GRADES | C4-1 |
| C.4.2.1 | Maximum Grades | C4-1 |
| C.4.2.2 | Minimum Grades | C4-2 |
| C.4.2.3 | Truck Climbing and Passing Lanes | C4-3 |
| C.4.2.4 | PCL (Microcomputer Program) | C4-3 |
| C.4.2.5 | Truck Escape Ramp | C4-3 |
| | | |
| C.4.3 | VERTICAL CURVES | C4-5 |
| C.4.3.1 | Function | C4-5 |
| C.4.3.2 | Form and Properties | C4-5 |
| C.4.3.3 | Designation | C4-5 |
| C.4.3.4 | Measurement of Stopping Sight Distance On Crest Curves | C4-5 |
| C.4.3.5 | Measurement of Stopping Sight Distance On Sag Curves | C4-7 |
| C.4.3.6 | Measurement of Passing Sight Distance | C4-7 |

CHAPTER C ALIGNMENT

| | | |
|--------------|---|--------------|
| C.4.4 | DESIGN CONTROLS | C4-9 |
| | C.4.4.1 Intersections | C4-9 |
| | C.4.4.2 Railway Crossings | C4-9 |
| | C.4.4.3 Vertical Clearances | C4-9 |
| | C.4.4.3.1 New Bridges Over Roadways | C4-9 |
| | C.4.4.3.2 Existing Bridges over Roadways | C4-9 |
| | C.4.4.3.3 Bridges Over Railways | C4-10 |
| | C.4.4.3.4 Bridges Over Non-Navigable Waterways | C4-10 |
| | C.4.4.3.5 Bridges Over Navigable Waterways | C4-10 |
| | C.4.4.3.6 Hydro, Telephone, and Telegraph Lines Over Roads | C4-10 |
| | C.4.4.3.7 Airways Over Roads | C4-10 |
| | C.4.4.3.8 Construction Clearances | C4-10 |
| | C.4.4.4 Drainage | C4-10 |
| | C.4.4.5 Minimum Curve Length | C4-11 |
| | C.4.4.6 Deviation From Standards | C4-11 |
| | C.4.4.7 Earthworks | C4-11 |
| C.4.5 | DESIGN PRINCIPLES AND APPLICATION. | C4-15 |
| | C.4.5.1 Selection of Elements | C4-15 |
| | C.4.5.2 Integration of Design Features | C4-15 |
| C.4.6 | DESIGN TECHNIQUES | C4-16 |
| | C.4.6.1 Mass-Haul Diagram | C4-16 |
| C.5 | COORDINATION OF HORIZONTAL AND VERTICAL ALIGNMENT | C5-1 |
| | C.5.1 AESTHETIC CONSIDERATIONS | C5-1 |
| | C.5.2 DESIGN PRINCIPLES | C5-1 |
| C.6 | DESIGN AIDS | C6-1 |
| | C.6.1 TEMPLATES | C6-1 |
| | C.6.1.1 Horizontal Curve Templates | C6-1 |
| | C.6.1.2 Vertical Curve Templates | C6-1 |
| | C.6.1.3 Sight Distance Templates and Their Application | C6-1 |
| | C.6.1.4 Design Vehicle Turning Templates | C6-1 |
| | C.6.2 TABLES | C6-3 |
| | C.6.2.1 Horizontal Alignment | C6-3 |
| | C.6.2.2 Vertical Alignment | C6-3 |
| | C.6.3 COMPUTER PROGRAMS (HIGHWAY DESIGN SYSTEMS) | C6-7 |

CHAPTER C ALIGNMENT

LIST OF TABLES

| | | |
|--------------|--|--------------|
| C2-1 | MINIMUM STOPPING SIGHT DISTANCE ON WET PAVEMENTS | C2-2 |
| C2-2 | STOPPING DISTANCE ON DRY PAVEMENTS | C2-3 |
| C2-3 | EFFECT OF GRADE ON STOPPING SIGHT DISTANCE IN WET CONDITIONS | C2-3 |
| C2-4 | MINIMUM PASSING SIGHT DISTANCE FOR DESIGN OF TWO-LANE HIGHWAYS | C2-5 |
| C3-1 | STANDARD CIRCULAR CURVES (radii in metres) | C3-2 |
| C3-2 | MINIMUM RADIUS DETERMINED FOR LIMITING VALUES OF e AND f | C3-2 |
| C3-3 | STANDARD RANGE OF SPIRAL PARAMETERS A (metres) | C3-9 |
| C3-4 | MAXIMUM RELATIVE SLOPE BETWEEN OUTER EDGE OF PAVEMENT AND CENTRELINE FOR TWO-LANE ROADWAY. | C3-9 |
| C3-5 | VALUES OF DESIGN ELEMENTS RELATED TO DESIGN SPEEDS AND CIRCULAR CURVE RADII $e_{max} = 0.06$ | C3-10 |
| C3-6 | VALUES OF DESIGN ELEMENTS RELATED TO DESIGN SPEEDS AND CIRCULAR CURVE RADII $e_{max} = 0.08$. | C3-11 |
| C3-7 | MAXIMUM SPEED (km/h) AT GIVEN SUPERELEVATION FOR RESURFACING PROJECTS | C3-12 |
| C4-1 | MAXIMUM GRADES (PERCENT) FOR RURAL ROADS | C4-1 |
| C4-2 | MAXIMUM GRADES (PERCENT) FOR URBAN ROADS | C4-2 |
| C4-3 | MAXIMUM GRADES (PERCENT) FOR FREEWAYS | C4-2 |
| C4-4 | MINIMUM GRADES | C4-2 |
| C4-5 | K - STANDARD VERTICAL CURVE VALUES | C4-5 |
| C4-6 | CREST CURVATURE | C4-6 |
| C4-7 | SAG CURVATURE, HEADLIGHT. | C4-6 |
| C4-8 | SAG CURVATURE, COMFORT. | C4-8 |
| C4-9 | PASSING SIGHT DISTANCE AND CURVATURE | C4-8 |
| C4-10 | HYDRO LINE CLEARANCE. | C4-12 |
| C4-11 | CLEARANCE* OF TELEGRAPH AND TELEPHONE LINES OVER ROADS | C4-12 |

CHAPTER C ALIGNMENT

LIST OF FIGURES

| | | |
|-------------|---|--------------|
| C2-1 | Passing Manoeuvre | C2-4 |
| C3-1 | Distribution of Superelevation | C3-6 |
| C3-2 | Method of attaining Superelevation for Curves Without Spirals | C3-6 |
| C3-3 | Method of Attaining Superelevation for Spiraled Curves | C3-7 |
| C3-4 | Family of Simple Spiral Curves | C3-8 |
| C3-5 | Segmental Spiral Curve. | C3-8 |
| C3-6 | Spiral Criteria | C3-9 |
| C3-7 | Lateral Clearance for Stopping Sight Distance for Level Condition | C3-14 |
| C4-1 | Properties of Vertical Curves. | C4-4 |
| C4-2 | Vertical Curve Parameter Criteria | C4-6 |
| C4-3 | Vertical Clearance to Airways | C4-13 |
| C4-4 | Adjacent Vertical Curves | C4-14 |
| C4-5 | Determination of Vertical Curve Elevations | C4-14 |
| C5-1 | Illustrations of Good and Poor Visual Quality | C5-2 |
| to | | to |
| C5-9 | | C5-10 |
| C6-1 | Typical Plan and Profile to Determine the Sight Distances Graphically. | C6-2 |

C.1 INTRODUCTION

C.1.1 DEFINITIONS

The horizontal alignment of a roadway is the configuration as seen in plan. The vertical alignment of a roadway is the configuration as seen in longitudinal section.

C.1.2 COMPONENTS

Horizontal alignment consists of tangents, circular curves, and spiral curves. Vertical alignment consists of tangents (usually known as grades) and parabolic curves. Vertical curves are referred to as crest or sag curves to indicate their orientation.

C.1.3 CONTROLS

The location of a roadway in both the horizontal and vertical planes is influenced by a number of controls. The primary determinant is design speed, a speed selected for design purposes to correlate the geometric elements of a roadway. It is the maximum safe speed that can be maintained over a specified section of roadway when traffic and weather conditions are so favourable that the design features of the roadway govern. The selection of design speed is a reflection of topography and cost.

Classification is a control and refers to the category of the road in terms of its environment, namely, rural or urban; its function, namely, a freeway, an arterial, a collector or local road and its design speed. The designation is by letters and figures, for example, a rural collector road of design speed 60 km/h is designated as RC 60.

Topography is an important factor in determining horizontal and vertical alignment, as severe terrain often imposes limitations on location and design elements. Flat terrain might have little influence on geometric design features, but might have significant influence on drainage design.

Climatic conditions might have a bearing on a number of geometric features. In horizontal alignment for example, climate might influence the selection of a route on one or the other side of the valley or ridge. In vertical alignment, the presence of drifting snow suggests a vertical alignment in fill, rather than cut to minimize snow on the pavement.

Traffic is a control which is taken into account in the design and all available information should be

considered. Current and projected traffic volumes are required, usually in terms of annual average daily traffic (AADT) or design hourly volume (DHV). Seasonal variations should be considered, particularly on roads likely to have high proportions of recreational traffic. An understanding of the mix of car and truck traffic is required to consider the need for climbing and passing lanes.

Soil formations might be a control in route selection and design, and the availability of sources and type of material influence route location. Muskeg is an unsatisfactory foundation material and normally has to be removed and replaced with suitable fill. This might incur additional cost compared with another route and therefore should be avoided. Rock excavation is more costly than earth excavation and therefore should be minimized as far as possible.

C.1.4 DESIGN CONSIDERATIONS

In addition to the controls discussed in C.1.3, there are a number of considerations to be taken into account in alignment design.

Safety is a primary consideration and should always be uppermost in the designer's mind. The careful selection and the coordination of the various geometric components can do much to promote safety to the travelling public. Fixed object accidents account for a significant number of injuries and fatalities, and these can be minimized by the judicious location of potentially hazardous objects and by the application of protective devices.

Roadway features should be selected so as to be consistent with driver behaviour. Driver expectations are based on his immediate past experience and on observations of roadway, terrain, environmental and traffic conditions. Designs that fail to meet these expectations, such as abrupt changes in some geometric feature might surprise the driver and precipitate hazardous conditions.

Cost is a significant consideration, and while it is important to minimize construction costs, an understanding of the benefits derived from additional expenditure is required.

Aesthetic considerations and environmental factors play an important part in modern road design. Social and natural environmental features should be clearly defined and understood at the time of the design, and the impact of alternative design features on environmental aspects should be considered. The appearance of the road to driver and passengers has a bearing on their sense of well-being. The factors to be examined for the environmental effects are: presence of historic, heritage or environmentally sensitive streams; agricultural land

capability, impacts and mitigating approaches; groundwater impacts; noise; wetlands, etc.

All proposed work projects must be reviewed and assessed for impact on the environment by Regional Environmental planners.

Drainage requirements have an impact on alignment design, particularly vertical alignment.

Design vehicles are hypothetical vehicles with particular geometric features adopted as representatives of each of the groups of vehicles using roads. A knowledge of the predominant or particular vehicles using any facility might influence the selection of some of the alignment features. Vehicle operating characteristics are also a consideration. The friction between pavement and tire, both laterally and longitudinally, has a bearing on speed-curve relationships and stopping capabilities. These characteristics are reflected in standards and should be understood in the application of standards.

The above design considerations are taken into account in the following sections of this chapter.

C.1.5 GEOMETRY

The horizontal and vertical elements of a road are described in terms of control lines. Control lines are lines mathematically defined in the horizontal and vertical planes. The horizontal control line is referenced to a coordinate grid, or a survey line referenced to known physical features. The vertical control line is referenced to a defined datum, usually sea level. Horizontal and vertical control lines might or might not be coincident. In two-lane roads the horizontal control is usually the centreline of the roadway and the vertical control is the elevation at the centreline of the roadway. In multi-lane divided highways, the horizontal control line might be the centreline of the median or, in some cases, the centreline of the roadway. The vertical control line is usually the inner edge of pavement.

On divided highways the roadways sometimes have independent vertical control lines. Ramp control lines are usually the right edge of pavement.

Chainage (also known as stationing) is the measurement of horizontal alignment from a given origin. It is frequently used as a reference and a means of describing a point on the horizontal control line. Chainage is expressed in linear measurement and the unit of chainage increment is one kilometre. It is expressed in metres and decimals of metres, and to delineate whole stations a plus sign is placed to the left of the third digit of the number in metres. For example, station 2+345.678 is 2.345 678 km or 2345.678 m from the origin.

Roads which are generally east-west in orientation are stationed increasing to the east, and roads which are generally north-south in orientation are stationed increasing to the north. Crossing roads are stationed from left to right looking forward along the mainline stationing.

A chainage equation is two references of chainages to the same point. It is expressed by a statement that the station of a point on one control line is equal to a different value on another control line, for example, 10+000.000 = 2+345.678. It is used to relate two horizontal control lines to each other, for example, where two roads cross or where a ramp departs from a main line.

A chainage equation sometimes occurs on a single control line, for example, where a new origin is adopted at the crossing of a municipal boundary, or where a modification to an alignment has shortened or lengthened it after stationing has been set.

In horizontal control lines, significant points at which different components meet are designated as follows, in each case looking along the alignment in the direction of increasing stationing:

- BC - Beginning of Curve
- EC - End of Curve
- TS - Tangent to Spiral
- ST - Spiral to Tangent
- SC - Spiral to Circular Curve
- CS - Circular Curve to Spiral
- PI - Point of Intersection
- POC - Point of Curve
- PCC - Point of Compound Curve
- SCS - Spiral to Spiral where $R \neq \infty$
- STS - Spiral to Spiral where $R = \infty$

In vertical alignment the points where tangents meet parabolic curves looking in the direction of increasing stationing are described as follows:

- BVC - Beginning of Vertical Curve
- EVC - End of Vertical Curve
- VPI - Vertical Point of Intersection

The following abbreviations are also used:

- HOC - hub on curve
- HOS - hub on spiral
- HOST - hub on subtangent
- HOT - hub on tangent

C.2 SIGHT DISTANCE

C.2.1 POLICY

THE SAFE AND EFFICIENT OPERATION OF A VEHICLE ON A HIGHWAY IS AFFECTED BY THE AVAILABILITY OF A DRIVER TO SEE AHEAD AND IS OF FUNDAMENTAL IMPORTANCE IN THE ROAD SYSTEMS. SUFFICIENT SIGHT DISTANCE MUST BE PROVIDED SO THAT DRIVERS CAN CONTROL THE SPEED OF THEIR VEHICLES TO AVOID STRIKING AN UNEXPECTED OBSTACLE IN THE TRAVELLED WAY.

IN ADDITION, IN THE CASE OF TWO-LANE HIGHWAYS, SUFFICIENT SIGHT DISTANCE FOR SAFE OVERTAKING MUST BE PROVIDED AT ACCEPTABLE INTERVALS, TO PROVIDE A REASONABLY GOOD LEVEL OF SERVICE AND ACCEPTABLE SAFETY TO DRIVERS.

In this section the sight distance required for safe stopping and safe passing is discussed. Criteria for measuring these sight distances and the methods of measuring are discussed in sections C.3.4.1, C.4.3.4, C.4.3.5 and C.4.3.6.

C.2.2 DEFINITIONS

Stopping sight distance is the distance ahead visible to the driver available to bring the vehicle to a stop. Minimum stopping sight distance is the least visible distance required by a driver to bring the vehicle to a stop before reaching an object in his path.

Passing sight distance is the distance ahead visible to the driver available to complete a passing manoeuvre. Minimum passing sight distance is the least visible distance required in order to make a passing manoeuvre safely, based on a given set of circumstances.

Passing opportunity sight distance is the distance ahead that must be visible to a driver in order to initiate a passing manoeuvre. This value is based more on the driver's perception of whether an opportunity to pass exists than on any absolute criteria and is discussed in more detail in Chapter B - Traffic and Capacity, Section B.4.4, Auxiliary Lanes.

C.2.3 STOPPING SIGHT DISTANCE

Stopping sight distance is comprised of three elements, namely:

- perception distance -
the distance travelled during the perception period, that is the time that elapses from the instant an object, for which the driver decides to stop, comes into view to the instant the driver decides to take remedial action.
- reaction distance -
the distance travelled during the reaction period, that is the time that elapses from the instant that the driver decides to take remedial action to the instant that he takes remedial action.
- braking distance -
the distance travelled from the time that braking begins to the time the vehicle comes to a stop.

C.2.3.1 Assumed Speed for Design

Minimum stopping sight distance values are based on wet pavement surface conditions, in recognition of the lower friction values of wet pavements. In adopting assumed speeds for the purpose of calculating minimum stopping sight distance, wet conditions are assumed to prevail.

The assumed speeds for calculating minimum stopping sight distance are based on a study of comparison of wet and dry speeds carried out by the Ministry. From this study, the 85th percentile wet weather speed was derived and was adopted as the assumed speed for calculation. For calculation of stopping distance in dry conditions, for comparison purposes, the design speed is used.

C.2.3.2 Perception and Brake Reaction Time

Perception time is the time elapsed from the instant that a driver observes an object for which it is necessary to stop until the instant that he decides to take remedial action. This is taken to be 1.5 s for all design speeds. Brake reaction time is the time elapsed from the instant the driver decides to take remedial action to the instant that remedial action begins, namely, application of the brake. This is taken to be 1.0 s giving a total perception and brake reaction time of 2.5 s. This value is adopted for all design speeds throughout the range.

C.2.3.3 Braking Distance

Braking distance is the distance travelled from the instant the brakes are applied to the instant a vehicle comes to a stop. Its calculation is based on the laws of motion in which it is assumed that the coefficient is constant throughout the braking period. The formula for calculating it is:

$$d = \frac{v^2}{254f}$$

where d is the braking distance in metres, v is the speed of the vehicle in kilometres per hour, and f is the coefficient of longitudinal friction between vehicle tires and pavement.

In adopting values for the coefficient of friction for minimum stopping sight distance, conditions approaching the worst are assumed, and the values adopted are consistent with the tires in poor condition operating on a pavement in poor condition with a wet surface.

Values for dry conditions, used for comparison purposes are higher than for wet conditions.

C.2.3.4 Design Values

Table C2-1 shows calculations of minimum stopping sight distance and values rounded for design for level conditions.

Table C2-2 shows calculations of stopping sight distances on dry pavements.

C.2.3.5 Adjustments for Grade

When braking occurs on a downgrade, the effect of the grade is to increase the braking distance. Conversely, on an upgrade the effect is to reduce the braking distance. To allow for the effect of grade on minimum stopping sight distance, Table C2-3 should be applied.

**Table C2-1
MINIMUM STOPPING SIGHT DISTANCE ON WET PAVEMENTS**

| Speed v | | Perception and Brake Reaction | | Coefficient of friction wet pav't | Braking distance on level | S-Min. Stopping sight distance | |
|---------|-------------------|-------------------------------|----------|-----------------------------------|---------------------------|--------------------------------|---------|
| Design | Assumed condition | Time | Distance | | | calculated | rounded |
| km/h | km/h | s | m | f | m | m | m |
| 40 | 40 | 2.5 | 28 | 0.380 | 17 | 45 | 45 |
| 50 | 50 | 2.5 | 35 | 0.358 | 27 | 62 | 65 |
| 60 | 60 | 2.5 | 42 | 0.337 | 42 | 84 | 85 |
| 70 | 70 | 2.5 | 49 | 0.323 | 60 | 109 | 110 |
| 80 | 79 | 2.5 | 55 | 0.312 | 79 | 134 | 135 |
| 90 | 87 | 2.5 | 60 | 0.304 | 98 | 158 | 160 |
| 100 | 95 | 2.5 | 66 | 0.296 | 120 | 186 | 185 |
| 110 | 102 | 2.5 | 71 | 0.290 | 141 | 212 | 215 |
| 120 | 109 | 2.5 | 76 | 0.283 | 165 | 241 | 245 |
| 130* | 116 | 2.5 | 81 | 0.279 | 190 | 271 | 275 |
| 140* | 122 | 2.5 | 85 | 0.277 | 211 | 296 | 300 |
| 150* | 127 | 2.5 | 88 | 0.273 | 232 | 320 | 320 |
| 160* | 131 | 2.5 | 91 | 0.269 | 251 | 342 | 345 |

*Design Speeds above 120 km/h are beyond the normal range of application

**Table C2-2
STOPPING DISTANCE ON DRY PAVEMENTS**

| Speed <i>v</i> | | Perception and Brake Reaction | | Coefficient of friction dry pav't | Braking distance on level | Stopping distance (calculated) |
|----------------|-------------------|-------------------------------|----------|-----------------------------------|---------------------------|--------------------------------|
| Design | Assumed condition | Time | Distance | | | |
| km/h | km/h | s | m | <i>f</i> | m | m |
| 40 | 40 | 2.5 | 28 | 0.625 | 10 | 38 |
| 50 | 50 | 2.5 | 35 | 0.618 | 16 | 51 |
| 60 | 60 | 2.5 | 42 | 0.603 | 24 | 66 |
| 70 | 70 | 2.5 | 49 | 0.590 | 33 | 82 |
| 80 | 80 | 2.5 | 56 | 0.580 | 43 | 99 |
| 90 | 90 | 2.5 | 63 | 0.570 | 56 | 119 |
| 100 | 100 | 2.5 | 69 | 0.562 | 70 | 139 |
| 110 | 110 | 2.5 | 76 | 0.553 | 86 | 162 |
| 120 | 120 | 2.5 | 83 | 0.545 | 104 | 187 |
| 130 | 130 | 2.5 | 90 | 0.540 | 123 | 213 |
| 140 | 140 | 2.5 | 97 | 0.535 | 144 | 241 |
| 150 | 150 | 2.5 | 104 | 0.530 | 167 | 271 |
| 160 | 160 | 2.5 | 111 | 0.528 | 191 | 302 |

**Table C2-3
EFFECT OF GRADE ON STOPPING SIGHT DISTANCE
IN WET CONDITIONS**

| Design Speed km/h | Assumed speed for condition km/h | Correction in Stopping Distance - metres | | | | | |
|-------------------|----------------------------------|--|----|----|-------------------------|----|----|
| | | Decrease for upgrades | | | Increase for downgrades | | |
| | | 3% | 6% | 9% | 3% | 6% | 9% |
| 40 | 40 | - | - | 5 | - | - | - |
| 50 | 50 | 5 | 5 | 10 | - | 5 | 10 |
| 60 | 60 | 5 | 5 | 10 | 5 | 10 | 15 |
| 70 | 70 | 5 | 10 | 15 | 5 | 10 | 20 |
| 80 | 79 | 10 | 15 | 20 | 10 | 15 | 30 |
| 90 | 87 | 10 | 20 | 25 | 10 | 20 | 40 |
| 100 | 95 | 10 | 20 | - | 15 | 30 | - |
| 110 | 102 | 15 | 25 | - | 15 | 35 | - |
| 120 | 109 | 20 | 30 | - | 20 | 40 | - |
| 130 | 116 | 25 | - | - | 20 | - | - |
| 140 | 122 | 25 | - | - | 25 | - | - |
| 150 | 127 | 25 | - | - | 25 | - | - |
| 160 | 131 | 30 | - | - | 30 | - | - |

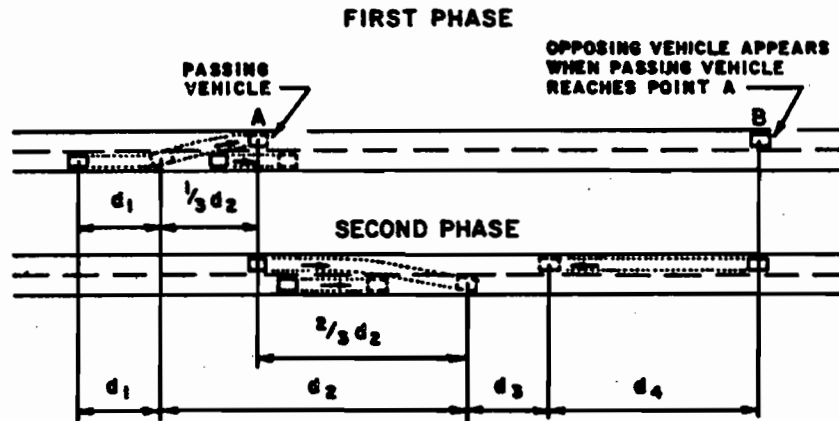

Figure C2-1
PASSING MANOEUVRE

C.2.4 PASSING SIGHT DISTANCE

C.2.4.1 Criteria for Design

To accomplish a passing manoeuvre with safety, the driver should see sufficient distance ahead, clear of traffic, to complete the passing manoeuvre without cutting off the overtaken vehicle before meeting an opposing vehicle which might appear after he has started to pass. To calculate minimum passing sight distance for design purposes, assumptions on traffic behaviour are necessary. These are:

- The overtaken vehicle travels at uniform speed.
- The passing vehicle has reduced speed and trails the overtaken vehicle as it enters the passing section.
- When the passing section is reached, the driver requires a short period of time to perceive the clear passing section and to react to start his manoeuvre.
- Passing is accomplished under a delayed start and a hurried return in the face of opposing traffic. The passing vehicle accelerates during the manoeuvre and the average speed during occupancy of the left lane is 16 km/h higher than that of the overtaken vehicle.

- When the passing vehicle returns to its lane there is a suitable clearance length between it and an oncoming vehicle in the other lane.

Based on these assumptions, the minimum passing sight distance for two-lane highways is determined by adding the following four elements shown in Figure C2-1.

- Distance travelled during perception time, reaction time and the initial acceleration to the point of encroachment on the left lane, d_1
- Distance travelled while the passing vehicle occupies the left lane, d_2
- Distance between the passing vehicle at the end of its manoeuvre and an opposing vehicle, d_3
- Distance travelled by an opposing vehicle for two-thirds of the time the passing vehicle occupies the left lane, d_4

These four elements, when added together, make up minimum passing sight distance.

C.2.4.2 Design Values

Table C2-4 shows minimum passing sight distance for a given range of design values indicating the assumed speeds of the overtaken vehicle and the passing vehicle, and minimum passing sight distance calculated and rounded for design.

C.2.5 INTERSECTION SIGHT DISTANCE

At intersections it is necessary to provide more than simply minimum stopping sight distance, since a vehicle entering an intersection just as another vehicle appears should clear the intersection so as not to impede progress of the vehicle on the through road. This is discussed more fully in Chapter E, At-Grade Intersections, Section E.3.

**Table C2-4
MINIMUM PASSING SIGHT DISTANCE
FOR DESIGN OF TWO-LANE HIGHWAYS**

| Design speed km/h | Assumed Speeds | | Minimum Passing Sight Distance, metres | |
|----------------------|------------------------|-------------------------|--|---------|
| | Passed Vehicle km/h | Passing Vehicle km/h | Calculated | Rounded |
| 50 | 44 | 59 | 350 | 350 |
| 60 | 51 | 67 | 426 | 450 |
| 70 | 58 | 74 | 493 | 500 |
| 80 | 66 | 82 | 559 | 550 |
| 90 | 72 | 88 | 620 | 650 |
| 100 | 78 | 94 | 678 | 700 |
| 110 | 84 | 100 | 734 | 750 |
| 120 | 90 | 106 | 788 | 800 |

C.3 HORIZONTAL ALIGNMENT

C.3.1 COMPONENTS

Horizontal alignment consists of tangents (straight lines), lengths of circular curve and lengths of spiral or transition curves.

C.3.2 CIRCULAR CURVES

C.3.2.1 Introduction

The purpose of a circular curve is to change the travel direction of the highway. Circular rather than any other form of curve is used for the convenience and ease of driver operation, and for consistency and simplicity in design. A circular curve is designated by its radius stated in metres.

Table C3-1 shows the complete set of 77 standard circular curve radii for use in design.

C.3.2.2 Speed-Radius Relationship

When a vehicle is travelling along a circular curve at a constant speed, it is experiencing an acceleration towards the centre of the circle. The centripetal force providing this acceleration is the friction between tire and pavement and if the travelled road is superelevated, the friction force is supplemented by a component of the force of gravity due to the weight of the car. This may be expressed mathematically by the formula:

$$e + f = \frac{v^2}{127R}$$

where e = pavement superelevation (tangent of the angle) the value of e being positive if the pavement slopes toward the centre of the curve

f = coefficient of side friction force between vehicle tire and road pavement

v = speed of the vehicle in kilometres per hour

R = radius of curve in metres

In a condition where $f = 0$, the entire centripetal force is provided by superelevation. This condition might occur on a large radius curve with slow-moving vehicles. If e , v and R are such that f exceeds the value that the pavement and tires can supply, lateral stability is lost and the vehicle will move away from the centre of the curve.

C.3.2.3 Maximum Superelevation

The maximum rate of superelevation that can be applied in highway design is controlled by several factors:

- climate conditions
- terrain
- type of development (rural or urban)
- maintenance

Consideration of these factors has led to the adoption of the following Ministry policy:

POLICY

THE MAXIMUM SUPERELEVATION RATE FOR URBAN FREEWAY INTERCHANGE RAMPS IS 0.08 m/m, WHERE A HIGH LEVEL OF MAINTENANCE PREVAILS, AND LITTLE ICE OR SNOW ACCUMULATION IS ANTICIPATED.

THE MAXIMUM SUPERELEVATION RATE FOR ALL OTHER ROADWAYS IS 0.06 m/m%.

A maximum rate of superelevation of 0.06 m/m is adopted for most roads since ice and snow are present in Ontario and vehicles travelling at slow speeds or moving away from a stopped position might experience side slip on higher superelevations. In the case of urban freeway interchange ramps the higher value of 0.08 m/m is used since this provides additional safety on roadways that tend to be overdriven more often and side slip is less likely to occur since maintenance is better at these locations.

C.3.2.4 Lateral Friction

Lateral friction available to assist a vehicle negotiating a circular curve varies with a number of factors. Among these are quality of tire tread and quality of pavement surface. Wet or icy pavements will provide less friction than dry ones and the presence of oil, mud, tire rubber and grit will have the effect of reducing friction.

On a given curve some vehicles travelling at speeds in excess of design speed can be expected and some vehicles changing lanes and overtaking will be following a path of smaller radius than the control line. These factors indicate that a safety factor incorporated into the lateral friction is appropriate.

Driver comfort is also taken into account in selecting lateral friction values. At higher speeds, if the centripetal force required to maintain the vehicle on the curve were supplied largely by lateral friction rather than superelevation, passengers would experience discomfort. The occupant would begin to feel insecure and the driver would tend to slow down.

**Table C3-1
STANDARD CIRCULAR CURVES**

| Radii in Metres (m) | | | | | | |
|---------------------|-----|-----|-----|------|------|-------|
| 45 | 100 | 180 | 340 | 600 | 1150 | 2500 |
| 50 | 105 | 190 | 350 | 650 | 1200 | 3000 |
| 55 | 110 | 200 | 380 | 700 | 1250 | 3500 |
| 60 | 115 | 210 | 400 | 750 | 1300 | 4000 |
| 65 | 120 | 220 | 420 | 800 | 1400 | 4500 |
| 70 | 125 | 230 | 450 | 850 | 1500 | 5000 |
| 75 | 130 | 240 | 475 | 900 | 1600 | 6000 |
| 80 | 140 | 250 | 500 | 950 | 1700 | 7000 |
| 85 | 150 | 280 | 525 | 1000 | 1800 | 8000 |
| 90 | 160 | 300 | 550 | 1050 | 2000 | 9000 |
| 95 | 170 | 320 | 575 | 1100 | 2200 | 10000 |

**Table C3-2
MINIMUM RADIUS DETERMINED FOR LIMITING VALUES OF e AND f**

| Design speed km/h | *max m/m | Max. f | Total e + f | Min. Radius (calculated) m | Min. Radius (rounded) m |
|----------------------|-------------|-----------|----------------|----------------------------------|-------------------------------|
| 40 | 0.06 | 0.165 | 0.225 | 55.99 | 55 |
| 50 | | 0.159 | 0.219 | 89.89 | 90 |
| 60 | | 0.153 | 0.213 | 133.08 | 130 |
| 70 | | 0.147 | 0.207 | 186.39 | 190 |
| 80 | | 0.140 | 0.200 | 251.97 | 250 |
| 90 | | 0.134 | 0.194 | 328.76 | 340 |
| 100 | | 0.128 | 0.188 | 418.83 | 420 |
| 110 | | 0.122 | 0.182 | 523.49 | 525 |
| 120 | | 0.115 | 0.175 | 647.92 | 650 |
| 130* | | 0.109 | 0.169 | 787.40 | 800 |
| 140* | | 0.103 | 0.163 | 946.81 | 1000 |
| 150* | | 0.098 | 0.158 | 1121.30 | 1150 |
| 160* | | 0.091 | 0.151 | 1334.93 | 1350 |
| 40 | 0.08 | 0.165 | 0.245 | 51.42 | 50 |
| 50 | | 0.159 | 0.239 | 82.36 | 80 |
| 60 | | 0.153 | 0.233 | 121.66 | 120 |
| 70 | | 0.140 | 0.227 | 169.97 | 170 |
| 80 | | 0.140 | 0.220 | 229.06 | 230 |
| 90 | | 0.134 | 0.214 | 298.04 | 300 |
| 100 | | 0.128 | 0.208 | 378.56 | 380 |
| 110* | | 0.122 | 0.202 | 471.66 | 475 |
| 120* | | 0.115 | 0.195 | 581.47 | 600 |
| 130* | | 0.109 | 0.189 | 704.08 | 700 |
| 140* | | 0.103 | 0.183 | 843.34 | 850 |
| 150* | | 0.098 | 0.178 | 995.31 | 1000 |
| 160* | | 0.091 | 0.171 | 1178.80 | 1200 |

*These values are beyond the normal range of application and are for information only.

The wide variation in available lateral friction and the need to meet the requirement discussed above has led to the adoption of friction factor values toward the low end of the range. Values for design are shown in Table C3-2.

C.3.2.5 Minimum Radii

If maximum values of lateral friction and superelevation are known for given speeds, minimum radii can be calculated.

Table C3-2 shows for a range of design speeds from 40 km/h to 160 km/h and for maximum values for superelevation of 0.06 m/m and 0.08 m/m.

Calculated values are derived from the expression

$$R_{\min} = \frac{V^2}{127(e_{\max} + f)}$$

C.3.2.6 Distribution of Superelevation

On a curve of minimum radius for a given design speed the maximum superelevation is applied. On tangent (a curve of $R = \infty$) the normal cross-fall is 0.02 m/m. In the range between tangent and minimum radius, the lateral force to provide centripetal acceleration is supplied by a combination of lateral friction and superelevation. It would be possible to permit an increase in lateral friction with no increase in superelevation until the radius decreases to that at which lateral friction reaches a maximum, and then for further reductions in curve radius superelevation would be increased as illustrated by line 1 in Figure C3-1.

On the other hand it would be possible to increase superelevation as radius decreases with no additional demand on lateral friction to maintain circular motion until maximum superelevation is reached for that particular radius. For further reduction in radius, friction would then be increased until the maximum friction and minimum curve radius were reached, illustrated by line 2 in Figure C3-1.

In practice a strategy between the two is adopted. From 0 to maximum superelevation both

superelevation and friction are increased steadily throughout the range, with superelevation increasing more rapidly on flatter curves and friction more rapidly on sharper curves, illustrated by line 3 in Figure C3-1.

This favours the overdriving characteristics that tend to occur on flat to intermediate curves. Overdriving on such curves is not dangerous since superelevation provides most of the force required to maintain circular motion.

Rates of superelevation for the range of design speeds and radii are shown in Tables C3-5 and C3-6.

C.3.2.7 Superelevation Transition and Tangent Runout

The normal cross-fall on a tangent section is 0.02 m/m and the superelevation on a curve of given radius is that indicated in Tables C3-5 and C3-6. The tangent runout is explained in Section C.3.3.6. In the case of a tangent and an adjacent circular curve without a spiral curve between them, the transition from 0 at the end of the tangent runout to full superelevation should be applied over a length at least equal to the spiral length derived from the tables. The length can be rounded to effect a convenient rate of change of superelevation; 60% of the length of the transition section should be on the tangent and 40% on the circular curve, illustrated in Figure C3-2.

Where a transition occurs near the end of a bridge, the horizontal alignment is usually adjusted if possible to keep the superelevation transition off the bridge and maintain the normal cross-fall or superelevation on the bridge.

C.3.2.8 Cross-fall and Superelevation for Resurfacing Projects

Guidelines for "cross-fall and superelevation for resurfacing projects", are provided in section D.4.3.5 of Chapter D.

Superelevation on curves may be less than design superelevation shown in Tables C3-5 and C3-6. Whenever superelevation is applied which is less than design superelevation, the maximum speed must be based on the acceptable standard for the rate of superelevation and the maximum friction factor 'f' for the range of radii as shown in Table C3-7.

C.3.3 SPIRAL CURVES

C.3.3.1 Function

The purpose of the spiral curve is to provide a transition between tangents and circular curves. It promotes smooth operation in that it follows the path that the driver naturally adopts. A transition curve provides a length over which superelevation can be developed and offers a more pleasing visual appearance to driver and passengers.

C.3.3.2 Form and Properties

The curve most commonly used for spirals in road design is the clothoid which expressed mathematically has the relationship R varies with the reciprocal of L.

$$R \propto \frac{1}{L}$$

$$RL = \text{constant}$$

$$RL = A^2$$

$$L = \text{Length of spiral}$$

In the above expression A is referred to as the spiral parameter and has the units of length. All clothoid spirals are the same shape and vary only in their size. The spiral parameter is simply a measure of the flatness of the spiral, the larger the parameter the flatter the spiral. A spiral in which one end of the spiral has a radius equal to infinity is referred to as a simple spiral and one in which the radii at both ends are less than infinity is referred to as a segmental spiral. Figure C3-4 shows a family of simple spiral curves and figure C3-5 shows a segmental spiral curve.

C.3.3.3 Designation

A simple spiral is designated by its parameter and its end radius. A segmental spiral is designated by its parameter and its two end radii. For design, spirals should always be selected from Table C3-3 of standard spiral parameters.

C.3.3.4 Basis of Design

Spiral design is based on three considerations, namely, comfort, superelevation and aesthetics, illustrated in figure C3-6.

Considering comfort, a vehicle travelling along a transition curve from tangent to the end radius at a constant speed experiences a centripetal force which

varies at a constant rate along the length of the transition. For a given speed and a given end radius, the rate of change of the centripetal force is a function of the length of the spiral, the shorter the spiral the more rapid the rate of change. If it is very short, passengers will experience a jerk. The rate of change of centripetal force is proportional to the rate of change of radial acceleration and this is a measure of the severity of the jerk. Tolerable radial acceleration varies between different drivers. As a basis for design, the value used as a maximum to provide minimum acceptable comfort and safety that will suit most passengers is 0.6 m/s^3 . Using this value for given speeds and end radii, minimum spiral parameters can be calculated using the expression:

$$A = 0.1464 \sqrt{\frac{v^3}{C}}$$

Where

A is spiral parameter, m

v is speed, km/h

C is rate of change of radial acceleration, m/s^3

For superelevation considerations, relative slope is the slope of the outer edge of a pavement in relation to the profile control line. It is dependent on the rate of superelevation being developed, the length over which it is developed and the width of pavement. The maximum permissible value varies with design speed, and is shown in Table C3-4.

The minimum length is given by the equation:

$$L = \frac{100 w e}{2s}$$

Where

w is the width of pavement in metres

e is the superelevation in metres per metre

s is the relative slope, percentage

L and w both being measured in metres. For a given speed and radius, superelevation and relative slope are known and minimum lengths can be calculated. From minimum length and radius, the minimum spiral parameter can be calculated, using the expression

$$A = \sqrt{RL}$$

Short spiral transition curves are visually unpleasant. It is generally accepted that the length of a transition curve should be such that the driving time is at least 2 s.

For a given radius and speed, therefore, the minimum length and minimum spiral parameter can be calculated by using the expression:

$$A \sqrt{Rv/1.8}$$

The three aspects above are illustrated in Figure C3-6 in which spiral parameter requirements are shown against radius. The minimum spiral requirement for design is the highest of the three values and it will be seen that for the smaller radii the comfort criterion controls, for the next larger set of radii relative slope criterion controls, and for the larger radii the aesthetic criterion controls.

C.3.3.5 Design Values

Spiral parameter values for design are shown in Tables C3-5 and C3-6. For each design speed and each radius two parameter values are given and should be regarded as minimum guideline values rather than absolute values, the first being for two-lane highways and the second for four-lane highways. Spiral values are shown rounded to the nearest whole metre. In design, radius and spiral parameter values should be selected so that both radius and spiral parameter are standard values and, if possible, such that A/R is a rational number to be used directly in Table III of "Circular and Spiral Curve Functions", Ministry publication. This allows the designer to use circular curve templates and to read off functions of spirals directly from the table.

Provided the criterion for A/R is met, a spiral parameter that provides a rational length of spiral may be

adopted. A value less than that shown in the tables may be adopted in the upper range where the aesthetic (2 s travel time) criterion governs the value.

C.3.3.6 Superelevation and Tangent Runout

A tangent section of road will normally have a cross-fall of -0.02 m/m and a circular curve has a constant superelevation related to speed and radius. (Cross-fall superelevation are negative where the pavement is falling away from the centreline). Figure C3-3(b) illustrates the development of superelevation by revolving the pavement about the centreline. This is the most common method of developing superelevation and is normally applied to two-lane highways.

The outside edge of the road is transitioned from a cross-fall of -0.02 m/m to full positive superelevation. The cross-fall is transitioned on the tangent runout section to 0 at the beginning of the spiral, using a slope on the outside pavement edge in relation to the centreline of 1:400. It is then transitioned over the length of the spiral from 0 to full superelevation at approximately a uniform rate. For the inside edge of the road, transitioning from -0.02 m/m to negative full superelevation, the normal cross-fall is maintained over the tangent runout section and along the transition until the superelevation in the other direction is equal to the normal cross-fall. It is then transitioned at a uniform rate from normal cross-fall to full superelevation. The length of tangent runout should be such that the rate of change of crossfall is no greater than the rate of change of superelevation on the transition curve.

Figure C3-3 also illustrates methods of attaining superelevation through revolving about the inside and outside edges of the pavement. These techniques are rarely applied to two-lane highways and are usually employed for divided highways.

DESIGN SPEED = 100 km/h
 MAXIMUM SUPERELEVATION = 0.08 m/m

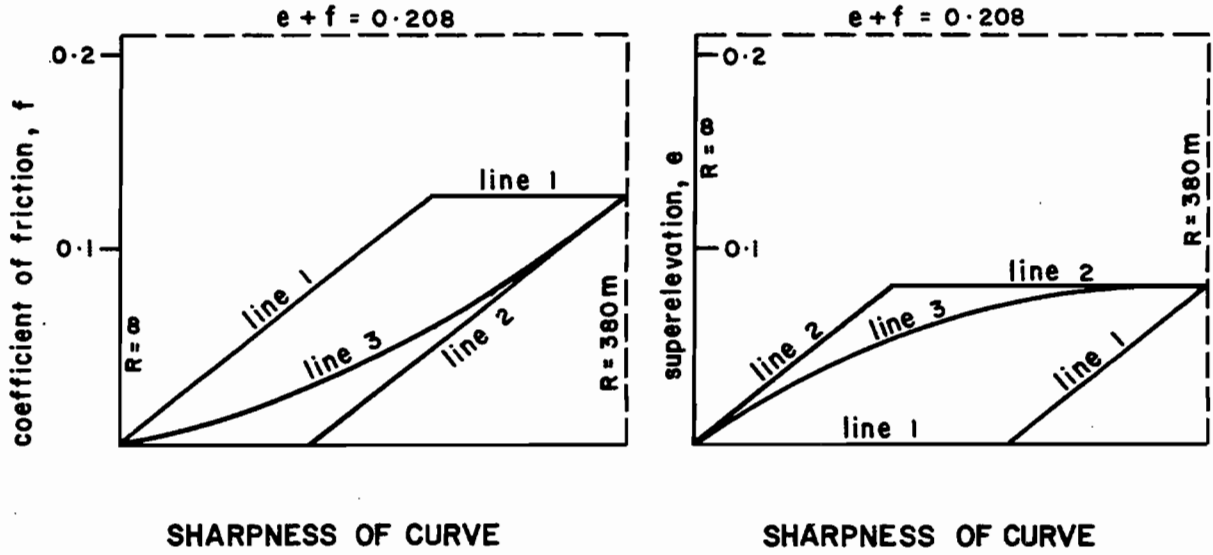

Figure C3-1
 Distribution of Superelevation

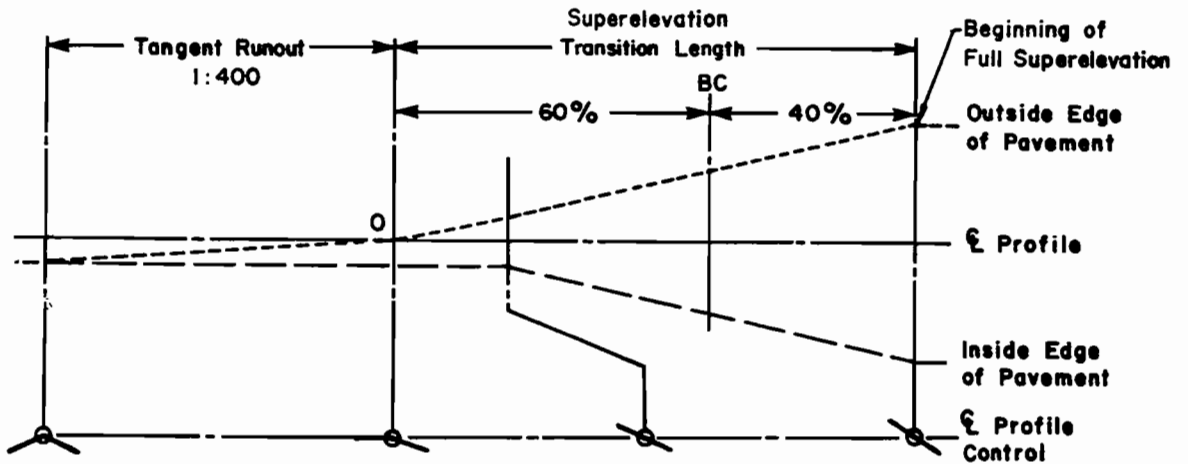
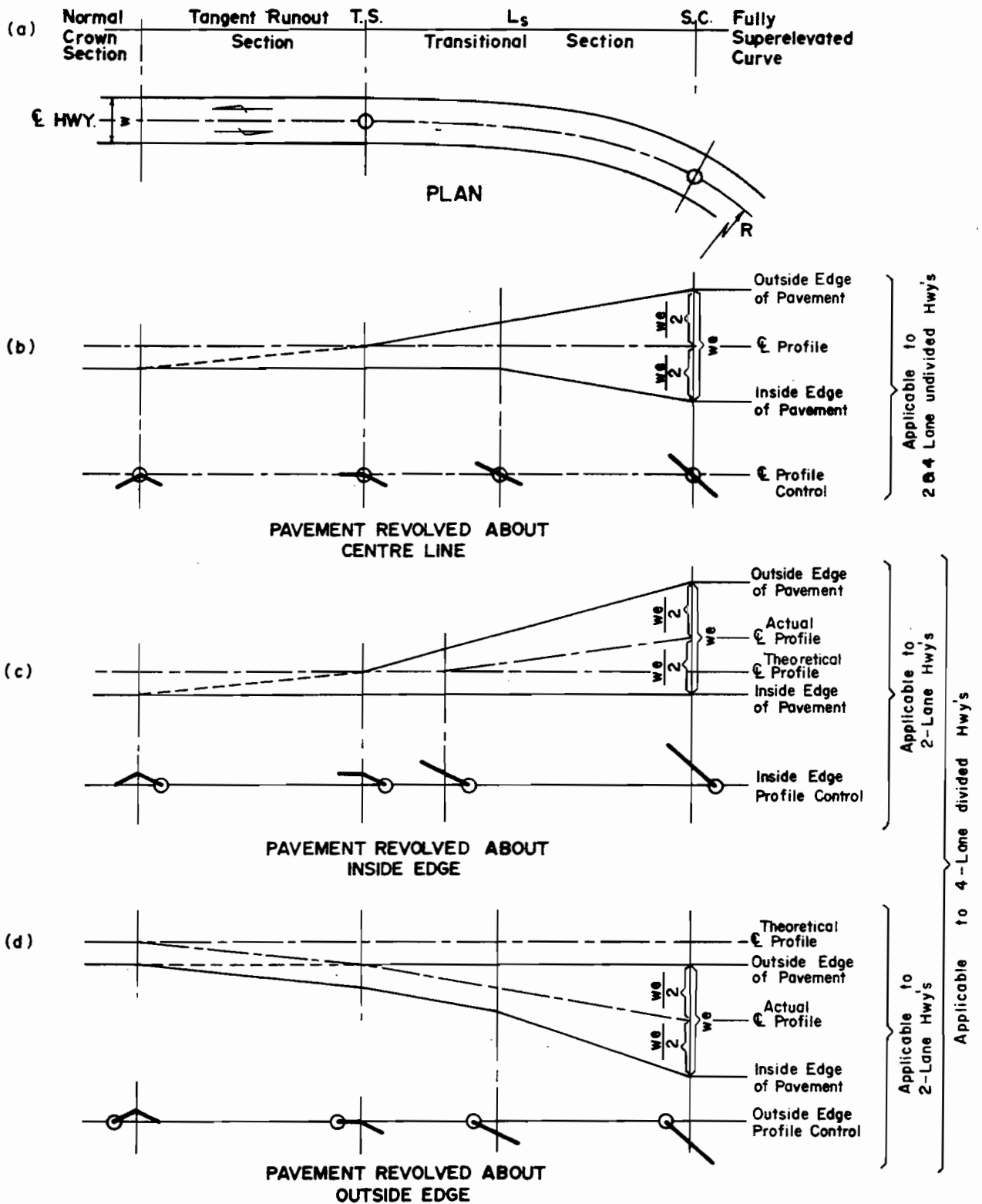

Figure C3-2
 Method of attaining Superelevation for Curves Without Spirals



Where

w is the width of pavement in metres
 e is the superelevation in metre per metre

Figure C3-3
 Method of Attaining Superelevation for Spiraled Curves

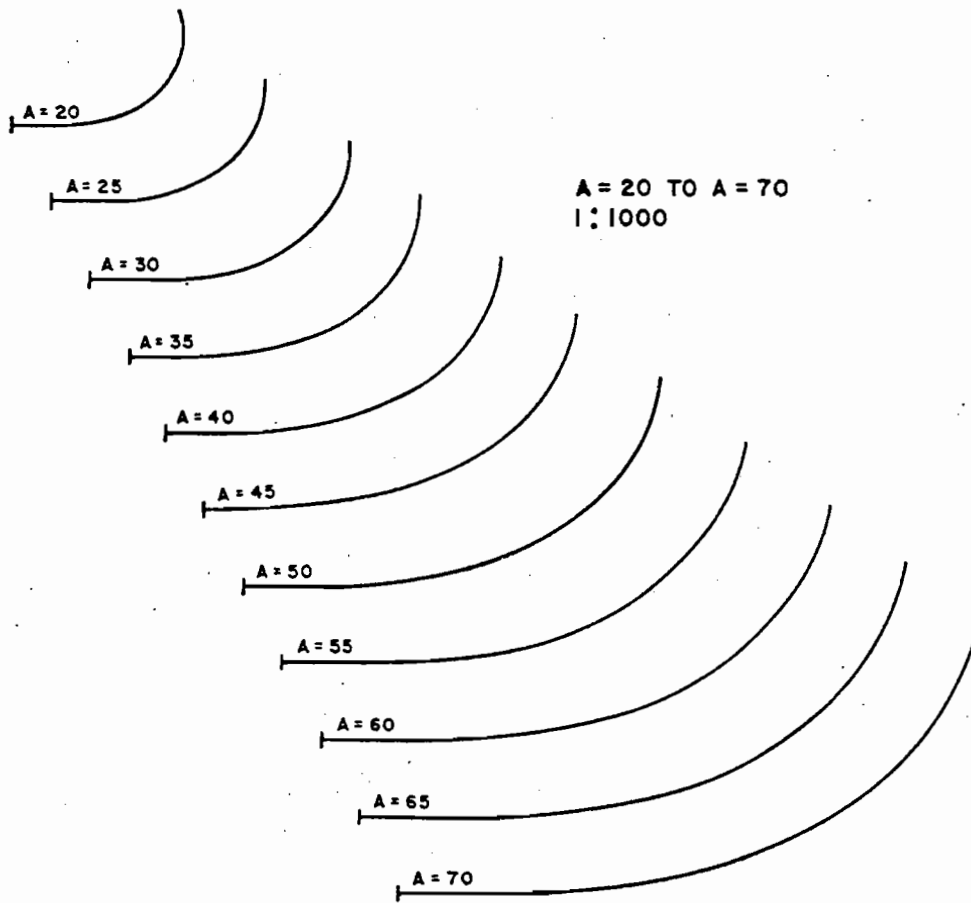

Figure C3-4
Family of Simple Spiral Curves

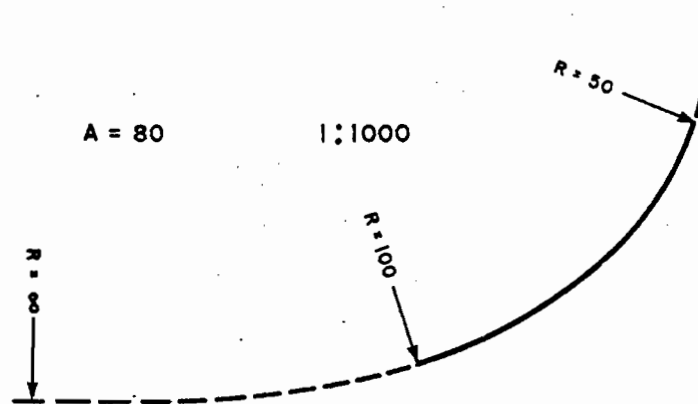

Figure C3-5
Segmental Spiral Curve

Table C3-3
STANDARD RANGE OF SPIRAL PARAMETERS A (metres)

| | | | | | | | |
|----|-----|-----|-----|-----|-----|------|------|
| 25 | 65 | 110 | 175 | 240 | 325 | 550 | 1100 |
| 30 | 70 | 120 | 180 | 250 | 350 | 600 | 1200 |
| 35 | 75 | 125 | 190 | 260 | 375 | 650 | 1300 |
| 40 | 80 | 130 | 200 | 270 | 400 | 700 | 1400 |
| 45 | 85 | 140 | 210 | 275 | 425 | 750 | 1500 |
| 50 | 90 | 150 | 220 | 280 | 450 | 800 | 1600 |
| 55 | 95 | 160 | 225 | 290 | 475 | 900 | 1700 |
| 60 | 100 | 170 | 230 | 300 | 500 | 1000 | 1800 |

Values above 700 are beyond the normal range of application.

Table C3-4
MAXIMUM RELATIVE SLOPE BETWEEN OUTER EDGE OF PAVEMENT AND CENTRELINE FOR TWO-LANE ROADWAY

| Design Speed, km/h | | | | | | | | | | | | |
|--------------------|------|------|------|------|------|------|------|------|------|------|------|------|
| 40 | 50 | 60 | 70 | 80 | 90 | 100 | 110 | 120 | 130 | 140 | 150 | 160 |
| Relative Slope, % | | | | | | | | | | | | |
| 0.70 | 0.65 | 0.60 | 0.55 | 0.51 | 0.47 | 0.44 | 0.41 | 0.38 | 0.36 | 0.34 | 0.32 | 0.30 |

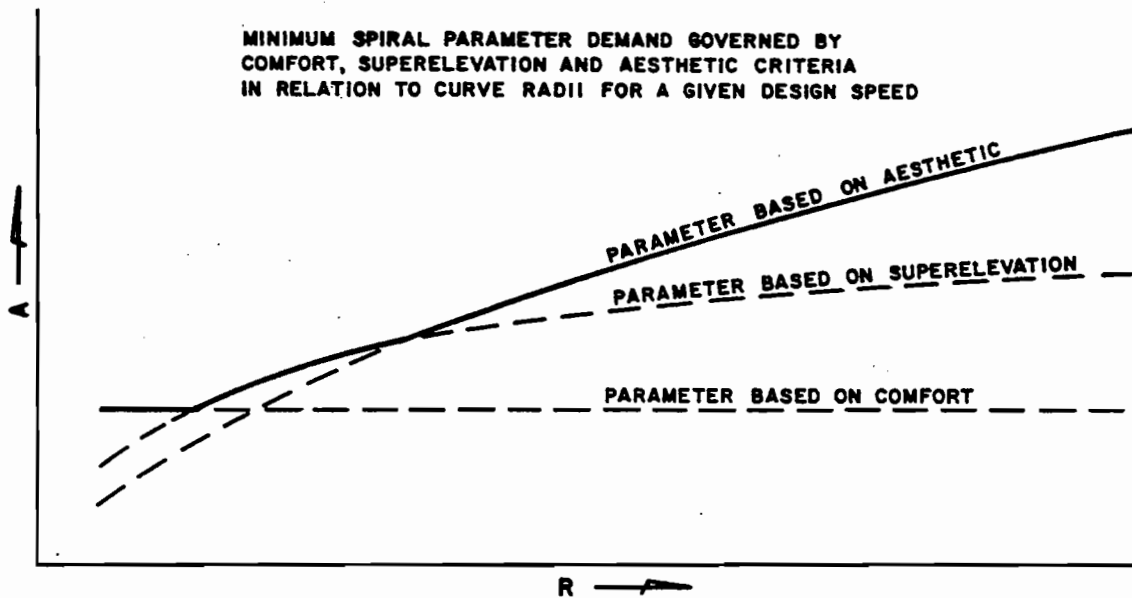

Figure C3-6
Spiral Criteria

Table C3-5
VALUES OF DESIGN ELEMENTS RELATED TO DESIGN SPEEDS AND CIRCULAR CURVE RADII $e_{max} = 0.06$

| V (km/h) A MIN (m) R (m) | 80 | | 70 | | 60 | | 50 | |
|--------------------------------|--------------------------------|--------------------------------|--------------------------------|--------------------------------|--------------------------------|--------------------------------|--------------------------------|--------------------------------|
| | V (km/h) A MIN (m) R (m) | V (km/h) A MIN (m) R (m) | V (km/h) A MIN (m) R (m) | V (km/h) A MIN (m) R (m) | V (km/h) A MIN (m) R (m) | V (km/h) A MIN (m) R (m) | V (km/h) A MIN (m) R (m) | V (km/h) A MIN (m) R (m) |
| 50 | 0.060 | 0.051 | 0.060 | 0.051 | 0.060 | 0.051 | 0.060 | 0.051 |
| 55 | 0.059 | 0.050 | 0.059 | 0.050 | 0.059 | 0.050 | 0.059 | 0.050 |
| 60 | 0.058 | 0.049 | 0.058 | 0.049 | 0.058 | 0.049 | 0.058 | 0.049 |
| 65 | 0.057 | 0.048 | 0.057 | 0.048 | 0.057 | 0.048 | 0.057 | 0.048 |
| 70 | 0.056 | 0.047 | 0.056 | 0.047 | 0.056 | 0.047 | 0.056 | 0.047 |
| 75 | 0.055 | 0.046 | 0.055 | 0.046 | 0.055 | 0.046 | 0.055 | 0.046 |
| 80 | 0.054 | 0.045 | 0.054 | 0.045 | 0.054 | 0.045 | 0.054 | 0.045 |
| 85 | 0.053 | 0.044 | 0.053 | 0.044 | 0.053 | 0.044 | 0.053 | 0.044 |
| 90 | 0.052 | 0.043 | 0.052 | 0.043 | 0.052 | 0.043 | 0.052 | 0.043 |
| 95 | 0.051 | 0.042 | 0.051 | 0.042 | 0.051 | 0.042 | 0.051 | 0.042 |
| 100 | 0.050 | 0.041 | 0.050 | 0.041 | 0.050 | 0.041 | 0.050 | 0.041 |
| 105 | 0.049 | 0.040 | 0.049 | 0.040 | 0.049 | 0.040 | 0.049 | 0.040 |
| 110 | 0.048 | 0.039 | 0.048 | 0.039 | 0.048 | 0.039 | 0.048 | 0.039 |
| 115 | 0.047 | 0.038 | 0.047 | 0.038 | 0.047 | 0.038 | 0.047 | 0.038 |
| 120 | 0.046 | 0.037 | 0.046 | 0.037 | 0.046 | 0.037 | 0.046 | 0.037 |
| 125 | 0.045 | 0.036 | 0.045 | 0.036 | 0.045 | 0.036 | 0.045 | 0.036 |
| 130 | 0.044 | 0.035 | 0.044 | 0.035 | 0.044 | 0.035 | 0.044 | 0.035 |
| 140 | 0.043 | 0.034 | 0.043 | 0.034 | 0.043 | 0.034 | 0.043 | 0.034 |
| 150 | 0.042 | 0.033 | 0.042 | 0.033 | 0.042 | 0.033 | 0.042 | 0.033 |
| 160 | 0.041 | 0.032 | 0.041 | 0.032 | 0.041 | 0.032 | 0.041 | 0.032 |
| 170 | 0.040 | 0.031 | 0.040 | 0.031 | 0.040 | 0.031 | 0.040 | 0.031 |
| 180 | 0.039 | 0.030 | 0.039 | 0.030 | 0.039 | 0.030 | 0.039 | 0.030 |
| 190 | 0.038 | 0.029 | 0.038 | 0.029 | 0.038 | 0.029 | 0.038 | 0.029 |
| 200 | 0.037 | 0.028 | 0.037 | 0.028 | 0.037 | 0.028 | 0.037 | 0.028 |
| 210 | 0.036 | 0.027 | 0.036 | 0.027 | 0.036 | 0.027 | 0.036 | 0.027 |
| 220 | 0.035 | 0.026 | 0.035 | 0.026 | 0.035 | 0.026 | 0.035 | 0.026 |
| 230 | 0.034 | 0.025 | 0.034 | 0.025 | 0.034 | 0.025 | 0.034 | 0.025 |
| 240 | 0.033 | 0.024 | 0.033 | 0.024 | 0.033 | 0.024 | 0.033 | 0.024 |
| 250 | 0.032 | 0.023 | 0.032 | 0.023 | 0.032 | 0.023 | 0.032 | 0.023 |
| 260 | 0.031 | 0.022 | 0.031 | 0.022 | 0.031 | 0.022 | 0.031 | 0.022 |
| 270 | 0.030 | 0.021 | 0.030 | 0.021 | 0.030 | 0.021 | 0.030 | 0.021 |
| 280 | 0.029 | 0.020 | 0.029 | 0.020 | 0.029 | 0.020 | 0.029 | 0.020 |
| 300 | 0.028 | 0.019 | 0.028 | 0.019 | 0.028 | 0.019 | 0.028 | 0.019 |
| 320 | 0.027 | 0.018 | 0.027 | 0.018 | 0.027 | 0.018 | 0.027 | 0.018 |
| 340 | 0.026 | 0.017 | 0.026 | 0.017 | 0.026 | 0.017 | 0.026 | 0.017 |
| 360 | 0.025 | 0.016 | 0.025 | 0.016 | 0.025 | 0.016 | 0.025 | 0.016 |
| 380 | 0.024 | 0.015 | 0.024 | 0.015 | 0.024 | 0.015 | 0.024 | 0.015 |
| 400 | 0.023 | 0.014 | 0.023 | 0.014 | 0.023 | 0.014 | 0.023 | 0.014 |
| 420 | 0.022 | 0.013 | 0.022 | 0.013 | 0.022 | 0.013 | 0.022 | 0.013 |
| 440 | 0.021 | 0.012 | 0.021 | 0.012 | 0.021 | 0.012 | 0.021 | 0.012 |
| 460 | 0.020 | 0.011 | 0.020 | 0.011 | 0.020 | 0.011 | 0.020 | 0.011 |
| 475 | 0.020 | 0.010 | 0.020 | 0.010 | 0.020 | 0.010 | 0.020 | 0.010 |
| 500 | 0.020 | 0.010 | 0.020 | 0.010 | 0.020 | 0.010 | 0.020 | 0.010 |
| 525 | 0.019 | 0.009 | 0.019 | 0.009 | 0.019 | 0.009 | 0.019 | 0.009 |
| 550 | 0.018 | 0.008 | 0.018 | 0.008 | 0.018 | 0.008 | 0.018 | 0.008 |
| 575 | 0.017 | 0.007 | 0.017 | 0.007 | 0.017 | 0.007 | 0.017 | 0.007 |
| 600 | 0.016 | 0.006 | 0.016 | 0.006 | 0.016 | 0.006 | 0.016 | 0.006 |
| 650 | 0.015 | 0.005 | 0.015 | 0.005 | 0.015 | 0.005 | 0.015 | 0.005 |
| 700 | 0.014 | 0.004 | 0.014 | 0.004 | 0.014 | 0.004 | 0.014 | 0.004 |
| 750 | 0.013 | 0.003 | 0.013 | 0.003 | 0.013 | 0.003 | 0.013 | 0.003 |
| 800 | 0.012 | 0.002 | 0.012 | 0.002 | 0.012 | 0.002 | 0.012 | 0.002 |
| 850 | 0.011 | 0.001 | 0.011 | 0.001 | 0.011 | 0.001 | 0.011 | 0.001 |
| 900 | 0.010 | 0.000 | 0.010 | 0.000 | 0.010 | 0.000 | 0.010 | 0.000 |
| 950 | 0.010 | 0.000 | 0.010 | 0.000 | 0.010 | 0.000 | 0.010 | 0.000 |
| 1000 | 0.010 | 0.000 | 0.010 | 0.000 | 0.010 | 0.000 | 0.010 | 0.000 |
| 1050 | 0.010 | 0.000 | 0.010 | 0.000 | 0.010 | 0.000 | 0.010 | 0.000 |
| 1100 | 0.010 | 0.000 | 0.010 | 0.000 | 0.010 | 0.000 | 0.010 | 0.000 |
| 1150 | 0.010 | 0.000 | 0.010 | 0.000 | 0.010 | 0.000 | 0.010 | 0.000 |
| 1200 | 0.010 | 0.000 | 0.010 | 0.000 | 0.010 | 0.000 | 0.010 | 0.000 |
| 1250 | 0.010 | 0.000 | 0.010 | 0.000 | 0.010 | 0.000 | 0.010 | 0.000 |
| 1300 | 0.010 | 0.000 | 0.010 | 0.000 | 0.010 | 0.000 | 0.010 | 0.000 |
| 1400 | 0.010 | 0.000 | 0.010 | 0.000 | 0.010 | 0.000 | 0.010 | 0.000 |
| 1500 | 0.010 | 0.000 | 0.010 | 0.000 | 0.010 | 0.000 | 0.010 | 0.000 |
| 1600 | 0.010 | 0.000 | 0.010 | 0.000 | 0.010 | 0.000 | 0.010 | 0.000 |
| 1700 | 0.010 | 0.000 | 0.010 | 0.000 | 0.010 | 0.000 | 0.010 | 0.000 |
| 1800 | 0.010 | 0.000 | 0.010 | 0.000 | 0.010 | 0.000 | 0.010 | 0.000 |
| 2000 | 0.010 | 0.000 | 0.010 | 0.000 | 0.010 | 0.000 | 0.010 | 0.000 |
| 2200 | 0.010 | 0.000 | 0.010 | 0.000 | 0.010 | 0.000 | 0.010 | 0.000 |
| 2500 | 0.010 | 0.000 | 0.010 | 0.000 | 0.010 | 0.000 | 0.010 | 0.000 |
| 3000 | 0.010 | 0.000 | 0.010 | 0.000 | 0.010 | 0.000 | 0.010 | 0.000 |
| 4000 | 0.010 | 0.000 | 0.010 | 0.000 | 0.010 | 0.000 | 0.010 | 0.000 |
| 4500 | 0.010 | 0.000 | 0.010 | 0.000 | 0.010 | 0.000 | 0.010 | 0.000 |
| 5000 | 0.010 | 0.000 | 0.010 | 0.000 | 0.010 | 0.000 | 0.010 | 0.000 |
| 6000 | 0.010 | 0.000 | 0.010 | 0.000 | 0.010 | 0.000 | 0.010 | 0.000 |
| 7000 | 0.010 | 0.000 | 0.010 | 0.000 | 0.010 | 0.000 | 0.010 | 0.000 |
| 8000 | 0.010 | 0.000 | 0.010 | 0.000 | 0.010 | 0.000 | 0.010 | 0.000 |
| 9000 | 0.010 | 0.000 | 0.010 | 0.000 | 0.010 | 0.000 | 0.010 | 0.000 |
| 10 000 | 0.010 | 0.000 | 0.010 | 0.000 | 0.010 | 0.000 | 0.010 | 0.000 |

$e_{max} = 0.06$

V - ASSUMED DESIGN SPEED
R - RADIUS OF CURVE
A - SPIRAL PARAMETER (MINIMUM VALUES)
e - RATE OF SUPERELEVATION
MC - NORMAL CROWN SECTION
RC - REMOVE CROWN SECTION

BELOW THE HEAVY LINE SPIRALS ARE DESIRABLE BUT MIGHT BE OMITTED UNDER RESTRICTED GEOMETRIC SITUATIONS.

- The indicated parameters are minimum values governed by comfort, superlevation and aesthetic criteria. (R.T.A.C. Manual provides rounded values)

- Wherever possible values in excess of those indicated should be selected such that the ratio A/R is a rational number

- Spiral length is calculated by the equation $L_s = A/R$, this value should also preferably be a rational number

- Indicated parameter for 4-lane highways applies to 2-lane undivided with profile control and 4-lane divided with median edge of pavement as profile control

- Caution should be exercised when utilizing large parameters on flat grades that may produce large pavement areas with little positive drainage

Table C3-7
 MAXIMUM SPEED (km/h) AT GIVEN SUPERELEVATION FOR RESURFACING PROJECTS

| RADIUS m | SUPERELEVATION m/m | | | | | | | | | | |
|-------------|--------------------|-------|-----|------|------|------|------|------|------|------|------|
| | -0.02 | -0.01 | 0 | 0.01 | 0.02 | 0.03 | 0.04 | 0.05 | 0.06 | 0.07 | 0.08 |
| 45 | 29 | 31 | 32 | 32 | 34 | 34 | 35 | 35 | 37 | 37 | 39 |
| 50 | 31 | 32 | 33 | 34 | 35 | 35 | 37 | 37 | 39 | 39 | 41 |
| 55 | 32 | 34 | 34 | 35 | 35 | 37 | 39 | 39 | 40 | 40 | 42 |
| 60 | 34 | 35 | 36 | 37 | 37 | 39 | 40 | 41 | 41 | 42 | 44 |
| 65 | 35 | 37 | 37 | 38 | 39 | 40 | 41 | 42 | 43 | 43 | 46 |
| 70 | 36 | 38 | 38 | 39 | 41 | 41 | 43 | 44 | 45 | 46 | 48 |
| 75 | 37 | 40 | 39 | 40 | 42 | 42 | 44 | 46 | 46 | 48 | 49 |
| 80 | 39 | 41 | 40 | 41 | 43 | 44 | 45 | 47 | 47 | 49 | 50 |
| 85 | 40 | 42 | 41 | 42 | 45 | 46 | 47 | 48 | 48 | 50 | 51 |
| 90 | 41 | 43 | 42 | 43 | 46 | 47 | 49 | 49 | 50 | 51 | 53 |
| 95 | 42 | 43 | 44 | 45 | 47 | 49 | 50 | 50 | 51 | 53 | 55 |
| 100 | 43 | 44 | 45 | 46 | 48 | 51 | 51 | 51 | 52 | 55 | 56 |
| 105 | 44 | 44 | 46 | 47 | 49 | 52 | 53 | 52 | 53 | 56 | 57 |
| 110 | 45 | 45 | 47 | 48 | 50 | 53 | 54 | 53 | 54 | 57 | 58 |
| 115 | 46 | 46 | 48 | 49 | 51 | 54 | 55 | 54 | 56 | 58 | 59 |
| 120 | 47 | 47 | 50 | 50 | 52 | 54 | 56 | 55 | 57 | 59 | 60 |
| 125 | 48 | 48 | 51 | 50 | 53 | 55 | 57 | 54 | 58 | 60 | 61 |
| 130 | 48 | 49 | 52 | 51 | 55 | 56 | 58 | 57 | 60 | 62 | 63 |
| 140 | 50 | 50 | 53 | 52 | 56 | 57 | 59 | 59 | 62 | 63 | 65 |
| 150 | 51 | 51 | 54 | 54 | 57 | 58 | 60 | 61 | 64 | 65 | 67 |
| 160 | 52 | 53 | 56 | 56 | 59 | 60 | 62 | 63 | 66 | 67 | 69 |
| 170 | 54 | 55 | 58 | 57 | 60 | 62 | 64 | 65 | 68 | 69 | 71 |
| 180 | 56 | 57 | 59 | 59 | 62 | 64 | 66 | 67 | 70 | 71 | 73 |
| 190 | 57 | 59 | 60 | 60 | 64 | 65 | 67 | 69 | 71 | 72 | 74 |
| 200 | 58 | 61 | 62 | 61 | 66 | 67 | 69 | 70 | 72 | 73 | 75 |
| 210 | 60 | 62 | 63 | 63 | 67 | 68 | 71 | 72 | 74 | 75 | 77 |
| 220 | 61 | 63 | 64 | 64 | 68 | 69 | 72 | 74 | 76 | 77 | 79 |
| 230 | 62 | 63 | 66 | 66 | 70 | 71 | 74 | 76 | 78 | 79 | 81 |
| 240 | 63 | 65 | 67 | 68 | 71 | 73 | 75 | 78 | 80 | 81 | 83 |
| 250 | 64 | 66 | 68 | 71 | 72 | 74 | 76 | 80 | 82 | 83 | 85 |
| 280 | 68 | 69 | 70 | 73 | 75 | 77 | 79 | 82 | 84 | 86 | 88 |
| 300 | 70 | 72 | 72 | 75 | 77 | 79 | 82 | 84 | 86 | 88 | 90 |
| 320 | 72 | 75 | 74 | 77 | 79 | 81 | 85 | 86 | 88 | 90 | 92 |
| 340 | 74 | 76 | 77 | 80 | 82 | 83 | 87 | 88 | 90 | 92 | 94 |
| 350 | 74 | 77 | 79 | 82 | 84 | 86 | 89 | 90 | 92 | 95 | 97 |
| 380 | 77 | 79 | 82 | 85 | 87 | 89 | 91 | 93 | 95 | 97 | 99 |
| 400 | 78 | 81 | 84 | 87 | 89 | 91 | 93 | 95 | 99 | 99 | 101 |
| 420 | 81 | 83 | 86 | 89 | 91 | 94 | 95 | 98 | 101 | 102 | 104 |
| 450 | 83 | 85 | 88 | 91 | 93 | 96 | 97 | 101 | 104 | 105 | 107 |
| 475 | 84 | 87 | 90 | 93 | 95 | 98 | 101 | 103 | 106 | 108 | 110 |
| 500 | 86 | 89 | 92 | 95 | 97 | 101 | 103 | 105 | 108 | 110 | 113 |
| 525 | 88 | 91 | 94 | 97 | 99 | 103 | 105 | 107 | 110 | 113 | 115 |
| 550 | 90 | 93 | 96 | 98 | 101 | 105 | 107 | 109 | 113 | 115 | 117 |
| 575 | 92 | 94 | 97 | 100 | 103 | 107 | 109 | 111 | 116 | 117 | 119 |
| 600 | 93 | 96 | 99 | 102 | 101 | 109 | 111 | 114 | 118 | 119 | |
| 650 | 96 | 99 | 102 | 105 | 109 | 111 | 114 | 117 | 120 | | |
| 700 | 98 | 102 | 105 | 108 | 111 | 114 | 117 | 121 | | | |
| 750 | 101 | 105 | 107 | 111 | 115 | 116 | 121 | | | | |
| 800 | 104 | 108 | 110 | 114 | 118 | 121 | | | | | |
| 850 | 107 | 110 | 112 | 117 | 121 | | | | | | |
| 900 | 109 | 113 | 116 | 120 | | | | | | | |
| 950 | 111 | 115 | 118 | | | | | | | | |
| 1000 | 113 | 117 | 121 | | | | | | | | |
| 1050 | 115 | 119 | | | | | | | | | |
| 1100 | 117 | 121 | | | | | | | | | |
| 1150 | 118 | | | | | | | | | | |
| 1170 | 119 | | | | | | | | | | |
| 1250 | 122 | | | | | | | | | | |

$$R = \frac{v^2}{127(e+f)}$$

C.3.4 DESIGN CONTROLS

C.3.4.1 Sight Distance

POLICY

MINIMUM STOPPING SIGHT DISTANCE VALUES SHOWN IN TABLE C2-1 SHOULD BE MAINTAINED ON HORIZONTAL CURVES, AND FOR PASSING, THE VALUES IN TABLES C2-4 ARE REQUIRED.

The criteria for measuring sight distance on horizontal curves are that the driver's eye and the object to be seen are in the centre of the inside lane. The sight distance is measured along the centre of the lane and the corresponding minimum lateral clearance at the mid-point can be calculated. Figure C3-7 shows lateral clearance for stopping sight distance, for a range of radii and design speeds. The adjustments for grade must be applied as outlined in Section C.2.3.5.

Where standard typical sections for earth cut are used, minimum stopping sight distance is available even for minimum radii. Remedial action may be required to provide minimum stopping sight distance in the case of rock cut, realigned or reconstructed roads that pass close to buildings, parapets on overpass ramps and closed abutment bridges on underpass ramps.

C.3.4.2 Minimum Curve Length

For deflection angles up to 0° 30' horizontal curves are not necessary. Curves having deflection angles between 0° 30' and 1° should be at least 350 m long. For curves having deflection angles between 1° and 5° the minimum length of curve is given by the expression $L = 400 - 50 \Delta$, where L is minimum length in metres and Δ is in degrees. Curves having a central angle above 5° should not be less than 150 m in length. For the purpose of determining curve length, where spiral curves are applied, 50% of the spiral is regarded as part of the curve.

The above general guidelines apply to rural roads in open country and do not apply to interchange ramps and turning roadways. In urban conditions, the selection of horizontal curves is strongly governed by property, cost and other restrictive constraints, and long curves are often not attainable.

It should be remembered that the longer the distance from which a curve is viewed, the more kinky its appearance and in these cases curves should be lengthened.

C.3.4.3 Intersections

Intersections are points of conflict and potential hazard. The alignment of the intersecting roads, therefore,

should permit drivers to discern and readily make the manoeuvres necessary to pass through the intersection with safety and with a minimum of interference between vehicles. To this end, alignment should be as straight as practicable.

At many places site conditions establish definite alignment and grade limitations on the intersecting roads. But often it is possible to modify alignment and grades to better suit traffic conditions and reduce hazards particularly on rural highways.

Regardless of the type of intersection, it is desirable for safety and economy that intersecting roads meet at or nearly at right angles. The practice of realigning roads to increase the angle of intersection has proved beneficial. While a right-angle crossing is desirable, some deviation is acceptable. Angles less than 70° and greater than 110° are not recommended. For the recommended angle of skew refer to section E.2.5.

Intersection of highways on sharp curves should be avoided wherever possible because of undesirable operational features. This aspect of design is discussed more fully in Chapter E, At-Grade Intersections.

C.3.4.4 Railway Crossings

For information, see Chapter E, Sections E.12 and E.3.6.

C.3.4.5 Deviation from Standards

For the most part in design, standards should be observed and minimum standards should be exceeded. However, in isolated instances where other controls pose a severe restraint in applying minimum standards, substandard horizontal geometry may be tolerated where there is no evidence of any geometric deficiency as indicated by the accident record. In such cases, curves should have radii and superelevations corresponding to speeds normally of not more than 10 km/h less than design speed, and in no case more than 20 km/h less. In assessing the implications of employing substandard curves, the designer should observe the following principles:

- Substandard horizontal curves are potentially serious since limiting values are based on lateral friction values and design speed and, therefore, near-limiting conditions occur frequently.
- Substandard horizontal curves should not be introduced adjacent to areas where speeds might be higher than either posted speed or design speed, for example, following long tangents, or at the bottom of a downgrade.

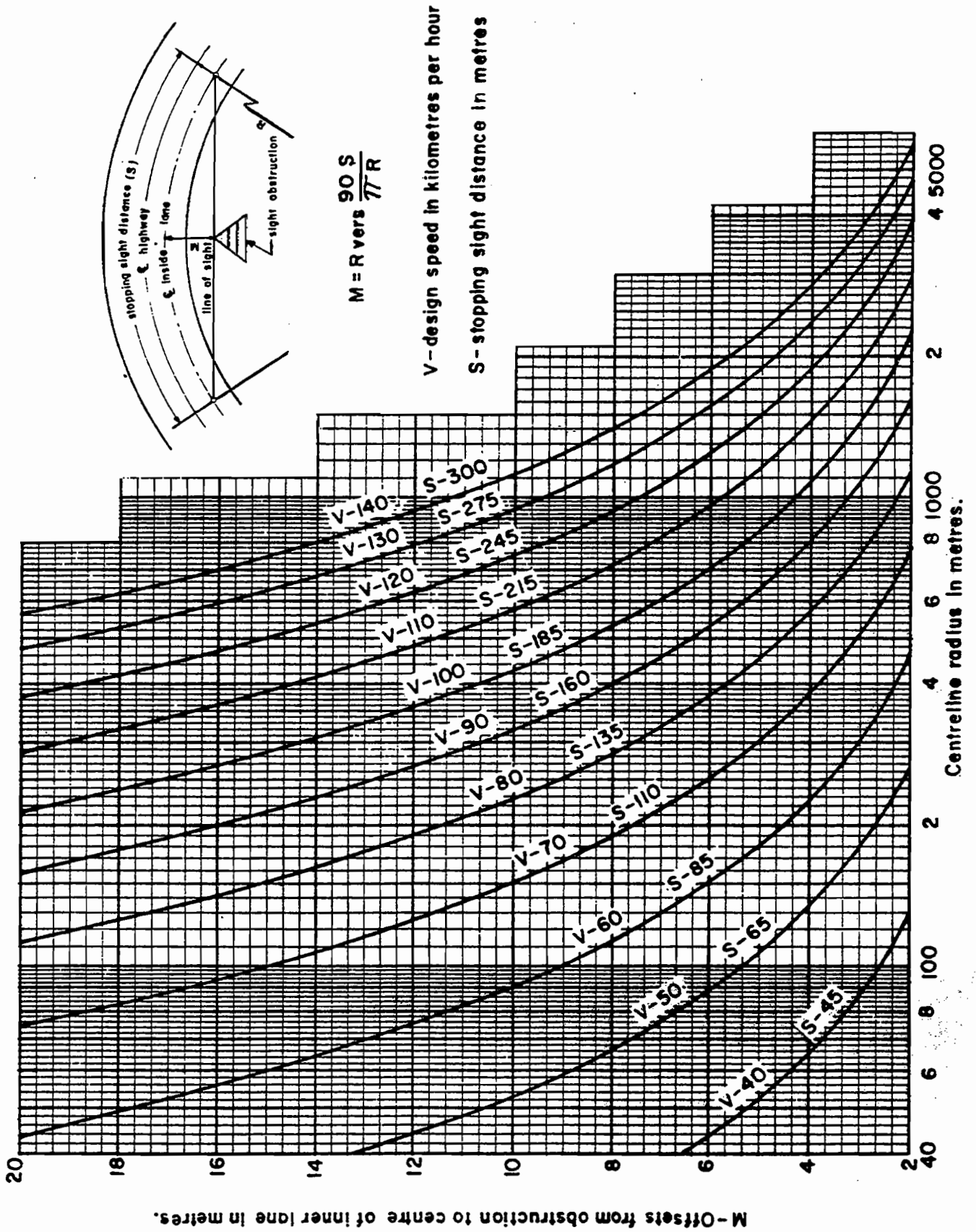

Figure C3-7
Lateral Clearance for Stopping Sight Distance for Level Condition

C.3.5 DESIGN PRINCIPLES AND APPLICATION

C.3.5.1 Spiraled Circular Curves

A circular curve with simple spirals at both ends, having the same parameter value, is referred to as symmetrical. If the spiral parameters have different values, the curve is referred to as unsymmetrical. Spiraled curves are normally symmetrical.

C.3.5.2 Segmental Spiral Curves

Successive circular curves in the same direction are normally joined by a length of spiral curve referred to as a segmental spiral. The minimum spiral parameter to be used is found by referring to Tables C3-5 or C3-6, and using the shorter of the two radii.

C.3.5.3 Compound Circular Curves

Successive circular curves in the same direction may be used and normally have a segmental spiral between them. The spiral may be omitted where the ratio of the longer radius to the shorter radius does not exceed 1.5. Circular curves in the same direction joined by a short length of tangent should be avoided for aesthetic reasons. For this purpose a short length may be regarded as that which allows a driver on the first curve to see at least some part of the following curve. Such a curve is usually referred to as broken-back curve. It would only be justified where some other consideration, for example, property or construction cost outweighs the visual disadvantages.

C.3.5.4 Spiral Curves Only

A change of direction from one tangent to another may be accomplished by successive spiral curves, that is a spiral curve of decreasing radius followed by a spiral of increasing radius without a length of circular curve between them. The transition curve is referred to as symmetrical where the two spiral parameters are the same, and unsymmetrical where they are different. The minimum permissible spiral parameter is the minimum for the design as shown in Tables C3-5 or C3-6.

C.3.5.5 Reverse Spiral Curves (Back-to-Back)

A reversal in curvature direction may be accomplished through successive simple spiral curves in which a spiral curve of increasing radius is followed immediately by a spiral of decreasing radius without a length of tangent between them. The spiral parameters should be at least the minimum for the design speed. However, the alignment will have an improved appearance if the minimum spiral parameter values are exceeded or if a length of tangent is inserted between the two curves.

Superelevation is applied as described in C.3.3.6 and superelevation will be zero where the two spirals meet. Drainage in this vicinity is effected longitudinally, and therefore, a reverse spiral should not coincide with flat longitudinal grades.

C.3.5.6 Integration of Design Features

When selecting the various components of a horizontal alignment design, in addition to respecting the controls noted in Sections C.2, C.3.2, C.3.3 and C.3.4, the designer should consider the integration of the individual components and the relationship of the horizontal alignment with the environment and surrounding terrain. Following are guidelines which should be observed:

- The use of minimum radius should be avoided wherever possible, since this represents the limiting condition.
- A sharp curve should not be introduced at the end of a long tangent.
- Sudden changes from long radius to short radius should be avoided.
- At the end of a long tangent section, a transition of gradually decreasing radius should be introduced to allow the driver to adjust his speed to the new condition. The additional length provides the opportunity for reducing speed safely.
- Sharp curves should not be introduced on high fills. In the absence of physical objects above the roadway, a driver may have difficulty in estimating the extent of the radius and fail to adjust to the conditions.
- Spirals should be used wherever possible rather than compounding circular curves.
- Abrupt reversal in alignment should be avoided. When reverse curves are too close it is difficult to superelevate them adequately, resulting in hazardous and erratic operation. A reversal in alignment can be suitably designed by introducing back-to-back spirals of sufficient length between two circular curves.
- Where it is necessary to change the widths of medians and shoulders, curvilinear tapers rather than tangents should be used to ensure smooth gradual tapers to appear to be a natural transition to the driver.
- Horizontal curves should lead vertical curves.

C.4 VERTICAL ALIGNMENT

- road classification
- traffic operation
- terrain
- costs
- property
- environmental implications

C.4.1 COMPONENTS

Vertical alignment consists of tangents (straight lines) and parabolic curves.

C.4.2 GRADES

The steepness of a gradient on tangent is expressed as a percentage, that is, the number of metres rise or fall over a horizontal length of 100 m. Looking in the direction of increasing stationing, upgrades are regarded as positive and downgrades as negative.

Where possible, it is desirable to use values for grades that are less than those provided in the tables. Alternatively, there may be situations where the maximum values must be exceeded. This should be done with a very careful assessment of all implications as stated.

The following guidelines should be considered when grades are selected from the tables:

C.4.2.1 Maximum Grades**POLICY**

THE STANDARD MAXIMUM GRADES FOR RURAL ROADS, URBAN ROADS AND FREEWAYS ARE GIVEN IN: TABLES C4-1, C4-2 AND C4-3.

A range of values for maximum grades is provided for each combination of design speed and traffic volume. Selection of the appropriate maximum grade from the range provided will depend on such considerations as

- On gradients of 3% or less passenger car operation is affected only to a very small degree and truck operation is affected only on long grades.
- On 5% grades passenger cars generally have no difficulty operating efficiently, but trucks will experience significant loss of speed and may have difficulty when roadways are icy.
- Maintenance and vehicle operating costs increase with steeper gradients.
- On divided highways with independent profiles for each roadway, the maximum values for downgrades can be exceeded by up to 2%.

**Table C4-1
MAXIMUM GRADES (PERCENT) FOR RURAL ROADS**

| DESIGN SPEED km/h | Traffic Volume | | | | | |
|----------------------|----------------|-----------|-----------|-----------|----------|------|
| | AADT | | | | | |
| | >4000 | 3000-4000 | 2000-3000 | 1000-2000 | 400-1000 | <400 |
| | DHV | | | | | |
| | >600 | 450-600 | 300-450 | 150-300 | 60-150 | <60 |
| 120 | 6-7 | - | - | - | - | - |
| 110 | 6-7 | 6-7 | 6-7 | 6-7 | - | - |
| 100 | 6-8 | 6-8 | 6-8 | 6-8 | 6-8 | - |
| 90 | 6-8 | 6-8 | 6-8 | 6-8 | 6-8 | - |
| 80 | 6-8 | 6-8 | 6-8 | 6-8 | 6-8 | 8 |
| 70 | - | 6-12 | 6-12 | 6-12 | 6-12 | 12 |
| 60 | - | - | - | 6-12 | 6-12 | 12 |
| 50 | - | - | - | - | - | 12 |

Table C4-2
MAXIMUM GRADES (PERCENT) FOR URBAN ROADS

| Design Speed km/h | Traffic Volume | | | | |
|----------------------|----------------|-------------|-------------|-------------|--------|
| | AADT | | | | |
| | >6000 | 3000 - 6000 | 2000 - 3000 | 1000 - 2000 | <1000 |
| | DHV | | | | |
| | >600 | 300 - 600 | 200 - 300 | 100 - 200 | <100 |
| 80 | 6 - 8 | 6 - 8 | 6 - 8 | - | - |
| 60 - 70 | 6 - 12 | 6 - 12 | 6 - 12 | 6 - 12 | - |
| 50 | - | - | 8 - 12 | 8 - 12 | - |
| 40 - 50 | - | - | - | - | 8 - 12 |

Table C4-3
MAXIMUM GRADES (PERCENT) FOR FREEWAYS

| Design Speed km/h | Maximum Grade % |
|----------------------|--------------------|
| 120 | 3 |
| 110* | 3 - 4 |
| 100* | 3 - 4 |
| 90* | 4 - 5 |

*Design speeds less than 120 km/h are not normally used for Freeways.

C.4.2.2 Minimum Grades

POLICY

STANDARD MINIMUM GRADIENTS FOR CURBED ROADS AND DITCHES ARE GIVEN IN TABLE C4-4.

On uncurbed roads where snow does not interfere with surface drainage, the road grade may be 0%, provided ditch grades conform to standards shown in Table C4-4.

On roadways with curbs, drainage is generally adjacent to the curb and longitudinal gradients must be set so as to avoid excessive accumulation of water on the pavement. Minimum gradients shown in the table can be used for the normal conditions of rainfall and outlet spacing. In special cases hydraulic analysis should be made to determine where water might spread onto the adjacent travel lane.

Table C4-4
MINIMUM GRADES

| Design Element | Grade | |
|---|-------------------|------------------|
| | Desirable Minimum | Absolute Minimum |
| Curbed Roads | 0.5% | 0.3% |
| Uncurbed Roads with Adequate Cross-Fall | 0.5% | 0.0% |
| Unlined Ditches | 0.5% | 0.1% |

C.4.2.3 Truck Climbing and Passing Lanes

On significant highway upgrades, heavy trucks and recreational vehicles can impede traffic flow and affect the safety of the traffic operation. The recommended safety improvement is the addition of a climbing lane. Passing lanes are introduced on two-lane rural highways where limited passing opportunity causes driver frustration.

Detailed information regarding warrants and design of truck climbing lanes and passing lanes is provided in Chapter B, Section B.4.4 and Chapter J, Section J.2.

C.4.2.4 PCL (Microcomputer Program)

PCL (Passing/Climbing Lane) is, in general, an automated version of the Ministry method described in Chapter B and it uses regression equations to calculate before and after conditions with respect to speed, delay, LOS and accident rates. This program does not provide any means to optimize the placement of the passing lane, the designer must rely on judgement and the guidelines in Chapter B. This program is a time saving tool which enables the designer to evaluate a section of highway quickly.

Input Requirements:

- section length
 - a default exists but any length can be used
- terrain type - hilly, rolling, level
- AADT
- DHV as percentage of AADT
- directional split
- percent truck/RV's
- peak hour factor
- percent no passing zones
- design speed
- posted speed
- grades and lengths of grades
- design truck specification

- 120 or 180 kg/kW

at this time these are the only two selections available although at some time in the future more design trucks may be added

- lane/shoulder width
- average or high platooning
- average accident costs
- average maintenance cost per unit length
- average construction cost per unit length

PCL uses the above specified data to evaluate the warrants and recommend whether passing or climbing lanes are warranted. Should they be, a length and a lane frequency will be recommended for the passing lane or for the climbing lane a length and a required location will be calculated based upon the 15 km/h (or otherwise specified) speed differential. In addition, the program provides LOS, delays, accident rates, construction and maintenance costs. As well, cost benefits are presented to assist the designer in decision making.

This software package is easy to use and can be introduced into the design office with a minimum of instruction. It is recommended that this program be used as a design aid.

The manual method for calculating passing and climbing lane warrants outlined in Chapter B, although quite simple in its calculations, can be tedious and time consuming if the designer is working with several candidate locations. The PCL program provides a speedy evaluation for the design process.

C.4.2.5 Truck Escape Ramps

On steep highway grades where runaway vehicles have been or could be a problem, truck escape ramps with or without truck arrestor beds may be used.

For information refer to 'Roadside Safety Manual' Section 5.4 'Truck Arrestor Beds'.

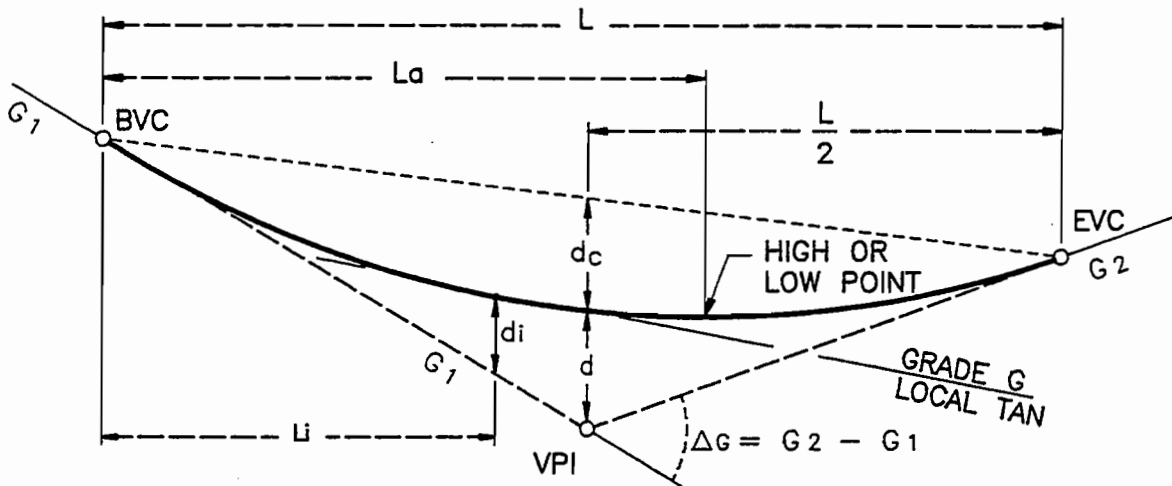

$$\Delta_G = G_2 - G_1 \quad K = \frac{L}{\Delta_G}$$

$$d = d_c = \frac{\Delta_G L}{800} = \frac{K \Delta_G^2}{800}$$

$$d_i = \frac{L_i^2}{\left(\frac{L^2}{2}\right)} \quad d = \frac{\Delta_G L_i^2}{200 L} = \frac{L_i^2}{200 K}$$

$$G = G_1 - \frac{L_i}{K} \quad L_a = G_1 K$$

Note:

Distances L , d , d_c , L_a , L_i , d_i , are in metres

Grades G_1 , G_2 , Δ_G , G are in percent.

Figure C4-1
Properties of Vertical Curves

C.4.3 VERTICAL CURVES

C.4.3.1 Function

The function of a vertical curve is to provide a smooth transition between adjacent grades.

C.4.3.2 Form and Properties

The form of curve used for vertical curves is a parabola positioned so that the axis is vertical. Crest vertical curves are those between two tangent sections in which either a positive grade is followed by a negative grade, a positive grade is followed by a lesser positive grade, or a negative grade is followed by a steeper negative grade. Sag vertical curves are those in which a negative grade is followed by a positive grade, a negative grade is followed by a lesser negative grade, or a positive grade is followed by a steeper grade.

One of the properties of the parabola is that the rate of change of grade with respect to length is constant. For this reason sight distance available to a driver travelling on a crest curve is constant throughout the length of the curve. This is one of the reasons for the use of the parabola for vertical curves. A second advantage of the parabolic curve is that its calculation is much simpler than a circular curve or any other curve that might be considered.

C.4.3.3 Designation

Figure C4-1 shows the basic properties of a vertical curve.

For a given curve K is a constant and is used to designate the size of the curve. K is the length of a section of curve measured horizontally over which there is a 1% change of gradient. K is therefore a measure of the flatness of a curve, the larger the K value the flatter the curve, in the same way that radius is a measure of the flatness of a circular curve. For crest curves K is negative, and for sag curves K is positive. K is equal to L, the length of the curve measured horizontally, divided by, Δ_G the change of gradient over the length of curve; $K = L / \Delta_G$

In design, standard K vertical curves should be selected from one of the values shown in Table C4-5.

C.4.3.4 Measurement of Stopping Sight Distance On Crest Curves

The method of calculating minimum stopping sight distance is discussed in Section C.2.3, and design

values for each of the standard design speeds are shown in Table C2-1. At the instant an object comes into view on a crest curve, the line of sight from the driver's eye to the top of the object is tangential to the curve. To ensure that minimum stopping sight distance is provided, the curve should be sufficiently flat so that the distance from the driver to the object is at least equal to minimum stopping sight distance. The minimum value for K therefore, is a function of minimum stopping sight distance, the height of the driver's eye and the height of the object above the pavement.

The height of the driver's eye above the pavement is dependent on the driver's physique and the car model driven. A Ministry study of cars registered in Canada for the three years 1971, 1972 and 1973 indicated that a value of 1.05 m was representative of passenger vehicles for those model years. A subsequent study carried out by the United States Federal Highway Administration resulted in the same recommendation. This value is adopted, therefore, for design.

The most common object a vehicle has to stop for is another vehicle ahead on the road and, therefore, for a height of object the legislative minimum height of taillight of 0.38 m is adopted.

Figure C4-2 illustrates the relationship between stopping sight distance, S, value for parabolic crest curve, K, height of object, h_2 and height of eye, h_1 .

Where the length of curve exceeds the stopping sight distance, K is given by the expression:

$$K = \frac{S^2}{200h_1(1 + \sqrt{h_2/h_1})^2}$$

Minimum Design values for each of the design speeds are shown in Table C4-6.

Where the stopping sight distance exceeds the length of curve, K is given by the Expression:

$$K = \frac{2S}{\Delta_G} - \frac{200h_1}{\Delta_G^2} (1 + \sqrt{h_2/h_1})^2$$

and the design should be checked by graphical means to ensure that minimum stopping sight distance is maintained. This may be done by use of the sight distance template discussed in Section C.6.1.3.

**Table C4-5
K - STANDARD VERTICAL CURVE VALUES**

| | | | | | | | | | | | | |
|----|----|----|----|----|-----|-----|-----|-----|-----|-----|-----|-----|
| 4 | 5 | 8 | 10 | 12 | 15 | 18 | 20 | 25 | 30 | 35 | 40 | 45 |
| 50 | 60 | 70 | 80 | 90 | 100 | 120 | 150 | 180 | 200 | 230 | 250 | 300 |

**Table C4-6
CREST CURVATURE**

| | | | | | | | | | | | | | |
|-------------------------------------|----|----|----|----|----|----|-----|-----|-----|------|------|------|------|
| Design Speed km/h | 40 | 50 | 60 | 70 | 80 | 90 | 100 | 110 | 120 | 130* | 140* | 150* | 160* |
| Min.(K) Crest Vertical Curve | 4 | 8 | 15 | 25 | 35 | 50 | 70 | 90 | 120 | 150 | 180 | 200 | 230 |

* See Table C3-2

**Table C4-7
SAG CURVATURE, HEADLIGHT**

| | | | | | | | | | | | | | |
|--|----|----|----|----|----|----|-----|-----|-----|------|------|------|------|
| Design Speed km/h | 40 | 50 | 60 | 70 | 80 | 90 | 100 | 110 | 120 | 130* | 140* | 150* | 160* |
| Min. (K) Sag Vertical Curvature Headlight Criterion | 8 | 12 | 18 | 25 | 30 | 40 | 45 | 50 | 60 | 70 | 80 | 90 | 100 |

* See Table C3-2

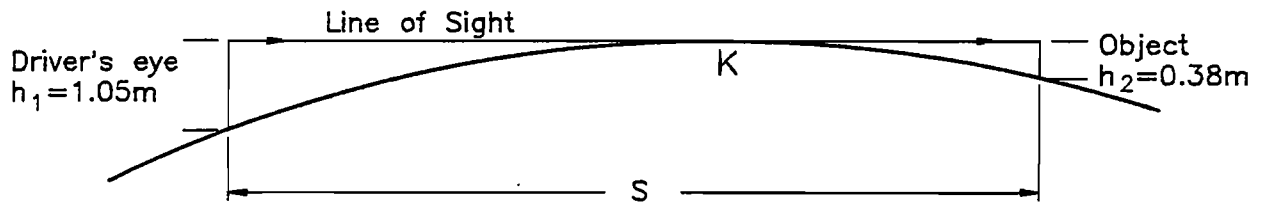

$$K = \frac{S^2}{200 h_1 (1 + \sqrt{h_2/h_1})^2}$$

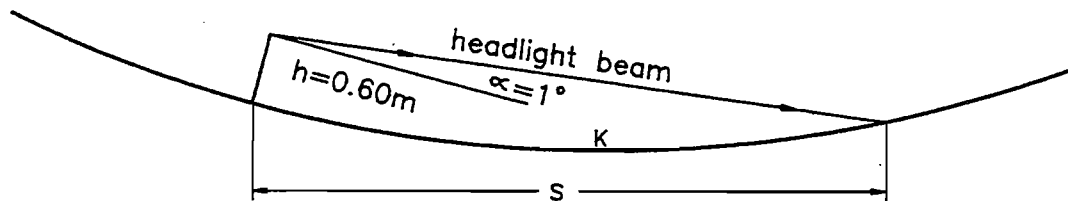

$$K = \frac{S^2}{200 (h + S \tan \alpha)}$$

**Figure C4-2
Vertical Curve Parameter Criteria**

C.4.3.5 Measurement of Stopping Sight Distance On Sag Curves

The method of calculating minimum stopping sight distance is discussed in Section C.2.3, and design values for each of the standard design speeds are shown in Table C2-1.

To provide adequate stopping sight distance on a sag curve, it should be sufficiently flat for a headlight beam to illuminate a distance ahead for a driver, at least equal to the minimum stopping sight distance. The height of the headlight above the pavement is taken to be 0.6 m and the angle of the light beam upward from the plane of the vehicle is taken to be 1°. From these criteria, minimum values corresponding to minimum stopping sight distances can be derived as shown in Figure C4-2. Minimum design values are shown in Table C4-7. Where good streetlighting prevails, normally associated with urban conditions, the headlight criterion does not apply since the driver is able to see further ahead than headlights illuminate. Under these conditions sharper curves can be introduced and comfort is the criterion that limits values. Passenger comfort is expressed mathematically in terms of centripetal acceleration at the bottom of the sag curve. The maximum acceptable centripetal acceleration is taken to be 0.3 m/s². Corresponding minimum K values for each standard design speed are calculated based on the following expression:

$$K = \frac{v^2}{390} \quad \text{where } v \text{ is assumed speed* in km/h}$$

These K values for sag curves are particularly useful in urban situations such as underpasses where it is often necessary for property and access reasons to depart from original ground elevations for as short a length as possible.

Minimum design values for each of the design speeds are shown in Table C4-8.

* See Table C2-1

Where comfort control values are used, minimum stopping sight distance should still be provided throughout the design.

C.4.3.6 Measurement of Passing Sight Distance

For passing sight distance, criteria for design and design values are discussed in Section C.2.4.

For measurement of passing sight distance on a vertical curve, the line of sight is taken to be tangential to the curve from the overtaking vehicle driver's eye to the top of the approaching vehicle. The height of the driver's eye is taken to be 1.05 m and the height of the opposing vehicle is taken to be 1.30 m. K values are calculated using the expression:

$$K = \frac{2S}{\Delta_G} - \frac{200h_1}{\Delta_G^2} (1 + \sqrt{h_2/h_1})^2$$

For crest curves where the length of curve is greater than the passing sight distance, the K value corresponding to the standard design speeds are given in Table C4-9.

In cases where the length of vertical curve is less than passing sight distance the design should be checked by graphical methods. Section C.6.1.3 discusses templates that may be used for this purpose.

Crest curvature K values are very much larger for passing sight distance than stopping sight distance, and it is rarely possible to provide minimum passing sight distance throughout a design. It is important for reasons of safety and service to provide as many passing opportunities as possible in each section of a road. The designer should ensure so far as possible that there is no long stretch where passing opportunity is not available.

**Table C4-8
SAG CURVATURE, COMFORT**

| Design Speed km/h | 40 | 50 | 60 | 70 | 80 | 90 | 100 | 110 | 120 |
|--|----|----|----|----|----|----|-----|-----|-----|
| Minimum sag vertical curvature K, comfort criterion | 4 | 5 | 8 | 12 | 15 | 20 | 25 | 25 | 30 |

**Table C4-9
PASSING SIGHT DISTANCE AND CURVATURE**

| Design Speed km/h | 50 | 60 | 70 | 80 | 90 | 100 | 110 | 120 |
|--|-----|-----|-----|-----|-----|-----|-----|-----|
| Minimum passing sight distance m | 350 | 400 | 475 | 525 | 600 | 650 | 725 | 775 |
| Minimum crest vertical curvature, K | 120 | 180 | 250 | 300 | 400 | 450 | 550 | 650 |

C.4.4 DESIGN CONTROLS**C.4.4.1 Intersections**

Intersections are points of conflict and potential hazard. The grade of the intersecting roads, therefore, should permit drivers to discern and readily make the manoeuvres necessary to pass through the intersection with safety and with a minimum of interference between vehicles. To this end, gradients should be as low as practicable.

Combinations of grade lines that make vehicle control difficult should be avoided at intersections. It is desirable to avoid substantial grade changes at intersections, but it is not always feasible to do so. Adequate sight distance should be provided along both highways and across the corners even where one or both intersecting highways are on vertical curves.

At all intersections where there are "yield" or "stop" signs, the gradients of the intersecting highways should be as flat as practicable on those sections that are to be used as storage space for stopped vehicles. However, a 1% minimum gradient is desirable to allow for reduction in cross-fall without impairing drainage. Intersections controlled by signals or which might be at some future date, should be generally flat.

Most vehicle operators are unable to judge the increase or decrease in stopping or accelerating distance necessary because of steep grades. Their normal deductions and reactions thus may be in error at a critical time. Accordingly, grades in excess of 3% should be avoided, if possible, on intersecting highways.

The grade and cross-sections on the intersection legs should be adjusted for a distance back from the intersection proper to provide a smooth junction and proper drainage. Normally the grade of the major highway should be carried through the intersection and that of the cross-road adjusted to it. This requires transition of the crown of the minor highway to an inclined cross-section at its junction with the major highway. Changes from one cross slope to another should be gradual. Intersections of a minor road crossing a divided highway with a narrow median and superelevated curve should be avoided whenever possible because of the difficulty in adjusting grades to provide a suitable crossing. Grades of separate turning roadways should be designed to suite the cross slopes and grades of the intersection legs.

C.4.4.2 Railway Crossings

For information see Chapter E, Sections E.12 and E.3.6

C.4.4.3 Vertical Clearances**C.4.4.3.1 New Structures Over Roadways****POLICY**

THE MINIMUM VERTICAL CLEARANCE OVER THE ROADWAY FOR NEW STRUCTURES SHALL BE:

- 4.8 m FOR SOLID OR CAST-IN-PLACE CONCRETE SLAB BRIDGES.
- 5.0 m FOR ALL OTHER VEHICULAR BRIDGES.
- 5.3 m FOR PEDESTRIAN AND BICYCLE BRIDGES.
- 4.8 m FOR SMALL LANE DESIGNATION SIGNS PROVIDED WITH A PIVOT MECHANISM WHICH WILL PREVENT DAMAGE TO THE SIGN OR SIGN SUPPORT STRUCTURE.
- 4.8 m FOR RAILWAY BRIDGES OVER ROADWAYS.
- 5.3 m FOR FIXED ATTACHMENTS, SUCH AS SIGN PANELS, OF SIGN SUPPORT STRUCTURES.
- 5.6 m FOR THE LOWEST STRUCTURAL MEMBERS, SUCH AS BOTTOM CHORD, OF SIGN SUPPORT STRUCTURES.

THE MINIMUM VERTICAL CLEARANCE OVER SIDEWALKS, BIKEWAYS AND SNOWMOBILE TRAILS SHALL BE 2.5 m.

Consideration should be given to a higher clearance for snow grooming equipment where required.

These dimensions take into account two resurfacings, live load deflection, foundation settlement, differential heaving of pavement and vehicle bounce.

ALL STRUCTURES HAVING A VERTICAL CLEARANCE LESS THAN THAT SPECIFIED ABOVE, SHALL REQUIRE APPROVAL BY THE JURISDICTIONAL AUTHORITY.

C.4.4.3.2 Existing Structures over Roadways**POLICY**

FOR EXISTING STRUCTURES WHERE THE HIGHWAY IS BEING RESURFACED OR RECONSTRUCTED, THE MINIMUM VERTICAL CLEARANCE OVER THE ROADWAY SHOULD BE:

(A) FOR STRUCTURES WHERE THE EXISTING VERTICAL CLEARANCE IS EQUAL TO OR GREATER THAN THOSE SPECIFIED IN C.4.4.3.1 THE FOLLOWING SHALL APPLY:

- 4.7 m FOR SOLID OR CAST-IN-PLACE CONCRETE SLAB BRIDGES
- 4.9 m FOR ALL OTHER VEHICULAR BRIDGES.
- 5.2 m FOR PEDESTRIAN AND BICYCLE BRIDGES.
- 4.7 m FOR RAILWAY BRIDGES
- 5.2 m FOR FIXED ATTACHMENTS.

(B) FOR STRUCTURES WHERE THE EXISTING CLEARANCE IS EQUAL TO OR LESS THAN THOSE SPECIFIED IN (A), THE EXISTING CLEARANCE SHALL BE MAINTAINED.

NOTE:

ALL EXISTING STRUCTURES WITH A CLEARANCE OF LESS THAN 4.5 m SHALL BE

SIGNED ACCORDINGLY. BRIDGES WITH A CLEARANCE LESS THAN 4.5 m MUST BE RECORDED IN THE ONTARIO STRUCTURE CLEARANCE AND LOAD INVENTORY SYSTEM (OSCLIS).

C.4.4.3.3 Bridges Over Railways

POLICY

MINIMUM VERTICAL CLEARANCE OVER RAILWAYS IS 7.2 m (23.5 feet) measured from the base of rail. Allowance should be made for curvature and superelevation of the track. Temporary clearances during construction, both vertical and horizontal, shall be as specified by the railway or railways having jurisdiction over the tracks.

C.4.4.3.4 Bridges Over Non-Navigable Waterways

POLICY

VERTICAL CLEARANCE BETWEEN THE LOWEST POINT OF THE SOFFIT AND THE DESIGN HIGH WATER LEVEL SHALL BE SUFFICIENT TO PREVENT DAMAGE TO THE STRUCTURE BY THE ACTION OF FLOWING WATER, ICE FLOWS, ICE JAMS OR DEBRIS, AND SHALL NOT BE LESS THAN 1.0 m FOR FREEWAYS, ARTERIAL ROADS AND COLLECTOR ROADS AND NOT LESS THAN 0.3 m FOR LOCAL ROADS. LOWER CLEARANCES OVER NON-NAVIGABLE WATERWAYS MAY BE USED FOR LOW VOLUME ROADS. LOWER CLEARANCES MAY ALSO BE USED, WITH APPROVAL FROM JURISDICTIONAL AUTHORITY, WHERE IT IS PROHIBITIVE TO USE THIS CRITERIA.

The design high water level referred to above includes the amount of backwater created by a bridge or culvert and is the higher of the water level corresponding to the design flood discharge under ice-free conditions and the highest recorded water level created by ice jams.

C.4.4.3.5 Bridges Over Navigable Waterways

POLICY

NAVIGATIONAL VERTICAL CLEARANCE IS DEPENDENT ON THE TYPE OF VESSEL USING THE WATERWAY AND SHOULD BE DETERMINED IN CONSULTATION WITH THE CANADIAN COAST GUARD, DEPARTMENT OF FISHERIES AND OCEANS.

Clearance should also conform to the requirements of the Navigable Waters Protection Act of Canada (NWPAC). The water level used as a basis for measuring navigational clearance should be the maximum likely to occur during the navigation season.

C.4.4.3.6 Approach Grade Elevation

POLICY

WHERE GEOMETRIC AND OTHER NON-HYDRAULIC CONSIDERATIONS PERMIT, FREEBOARD FROM THE EDGE OF THROUGH TRAFFIC LANES TO THE DESIGN HIGH-WATER SHALL BE 1.0 m FOR FREEWAYS, ARTERIAL

AND COLLECTOR ROADS AND 0.3 m FOR OTHER ROADS.

WHERE GEOMETRIC AND OTHER CONDITIONS PERMIT, THE APPROACH ROADWAY SHALL BE PLACED AT AN ELEVATION THAT WILL NOT BE OVERTOPPED DURING THE NORMAL DESIGN FLOOD BUT WILL MAXIMIZE RELIEF OVERFLOW DURING THE REGULATORY OR OTHER EXTREME FLOOD.

FREEBOARD FOR ROUTES UNDER STRUCTURES CROSSING WATER:

Freeboard for highways under bridges that cross water shall be in accordance with the freeboard criteria for the approach grade elevations.

Freeboard for walkways, cycle paths and maintenance access roads under structures crossing water shall be at least 1.0 m above the water level for spans of more than 6.0 m and at least 500 mm for spans of 6.0 m or less. These values shall be increased where high maintenance costs are likely to result from use of the minimum values.

C.4.4.3.7 Minimum Vertical Clearances for Aerial Cable Systems

POLICY

THE MINIMUM VERTICAL CLEARANCES FOR AERIAL CABLE SYSTEMS SHALL BE IN ACCORDANCE WITH THE ONTARIO PROVINCIAL STANDARD DRAWING OPSD – 217.03.

C.4.4.3.8 Airways Over Roads

POLICY

MINIMUM VERTICAL CLEARANCE TO AIRWAYS IS AS INDICATED IN FIGURE C4-3.

The dimensions are a guide only and specific dimensions should be approved by the Regional Superintendent, Airways, Transport Canada.

C.4.4.3.9 Construction Clearances

Construction clearances should conform to the requirements of the agency having jurisdiction over the roadway.

POLICY

THE MINIMUM VERTICAL CLEARANCES TO TEMPORARY FALSEWORK SHALL BE:

- (I) 4.5 M FOR SOLID OR CAST-IN-PLACE CONCRETE SLAB BRIDGES OVER ROADWAYS.**
- (II) 5.0 M FOR ALL GIRDER TYPE VEHICULAR BRIDGES OVER ROADWAYS.**
- (III) 4.7 M FOR PEDESTRIAN OR BICYCLE BRIDGES OVER ROADWAYS.**
- (IV) 4.5 M FOR RAILWAY BRIDGES OVER ROADWAYS.**

C.4.4.4 Drainage

Where uncurbed sections are used and drainage is effected by side ditches, there is no limiting minimum value for gradient or limiting upper value for vertical curves.

On curbed sections where storm water drains longitudinally in gutters and is collected by catch basins, vertical alignment is affected by drainage requirements. Minimum gradients are discussed in Section C.4.2.2.

On flat crest and sag curves, storm water might run sufficiently slowly so as to spread onto the adjacent travelled lane. There is a level point at the crest of a vertical curve, but generally no difficulty with drainage on curbed pavements is experienced if the curve is sharp enough so that the minimum gradient of 0.30% is reached at a point about 15 m from the crest. This corresponds to a K value of 50 m. Where a crest of K value greater than 50 m is used, special attention is needed to assure proper pavement drainage near the apex of the curve, for example, the application of more frequent catch basins.

For sag vertical curves the same criterion for crest curves applies, that is, the minimum grade of 0.30% is reached within 15 m of the level point. For a sag curve value of K greater than 50 m, special attention is required. Sag vertical curves normally occur in fill sections. In general, sag curves should be avoided in cut section since they often present drainage problems. If there are compelling reasons for a sag curve to occur in cut, for example, aesthetic considerations, precautions should be taken to ensure adequate drainage can be effected. This might be regrading the downstream side of a watercourse.

Long spiral curves on low gradient could produce flat areas with correspondingly poor drainage, and should be avoided.

C.4.4.5 Minimum Curve Length**POLICY**

THE MINIMUM LENGTH OF A VERTICAL CURVE IN METRES SHOULD BE NOT LESS THAN THE DESIGN SPEED IN KILOMETRES PER HOUR.

Example;

If the design speed is 100 km/h, the vertical curve length should be at least 100 m, except where drainage is of primary consideration, see Section C.4.4.4. Vertical curves applied to small changes of gradient should have K values significantly greater than the minimum as shown in Tables C4-6 and C4-7.

C.4.4.6 Deviation From Standards

Vertical curves that provide less than minimum stopping sight distance as stated in Table C2-1 are hazardous only if the assumptions upon which the corresponding minimum curvature values were based apply. For example, in the case of a crest curve if the stopping sight distance is less than minimum, but

there is no object in the path of an approaching vehicle, the curve is not hazardous. It is potentially hazardous because an object might be present. On the other hand, a substandard horizontal curve is one in which the lateral friction is insufficient to maintain dynamic equilibrium when driven at design speed. In short, it is hazardous to any vehicle driving at design speed and is not dependent on the presence or absence of any particular variable condition.

Isolated substandard vertical curves might be tolerated where there is no evidence of any geometric deficiency as indicated by the accident record. Such curves should have minimum K values for design speeds preferably not more than 10 km/h less than design speed and, in any case, not more than 20 km/h less.

In assessing the implications of employing substandard curves, the designer should be guided by the following principles:

- Substandard horizontal curves have a greater effect than vertical curves.
- Crest vertical curves are more critical than sag curves.
- Substandard vertical curves are hazardous when all the criteria on which the standards are based prevail.
- Substandard horizontal and vertical curves not be employed together.
- Substandard crest vertical curves should be avoided in the vicinity of intersections or areas where a large number of entrances may generate substantial turning traffic.

C.4.4.7 Earthworks

The extent and nature of earthworks required to construct a road might be a control and could influence the vertical design of a road. The profile should be adjusted to optimize earthwork costs without compromising on geometric and aesthetic quality. This might be achieved by designing for an earthworks balance. However, it might be more economical to design for overall borrow, surplus or even both, depending on availability, cost, and location of surplus and required borrow.

The mass-haul diagram is a technique to determine the quantity and location of excavation and fill in any particular design, and can be used to make adjustments to optimize earthworks cost. It is described in Section C.4.6.1.

System 050 is a program used to calculate earthwork quantities and may be used to generate a mass-haul diagram. See Section C.6.3.6.

Highway Optimization Program System (HOPS) is a package of computer programs capable of optimizing a profile to give the most economical profile based on a given set of controls and parameters. This is described in Section C.6.3.5.

THIS PAGE INTENTIONALLY LEFT BLANK

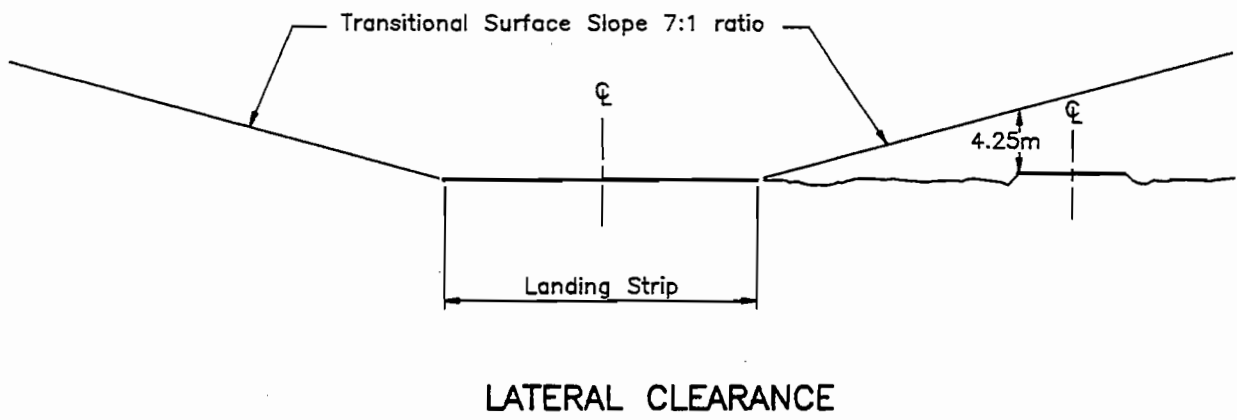
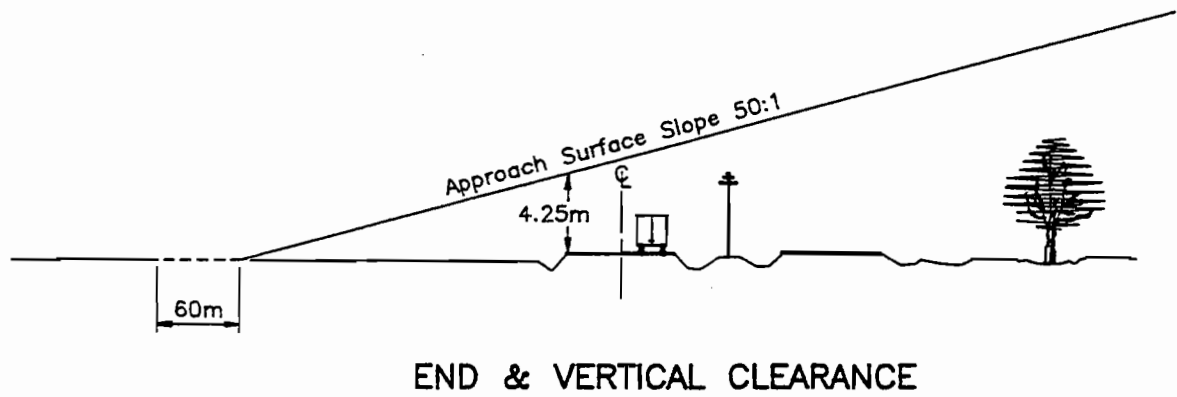

Figure C4-3
Vertical Clearance to Airways

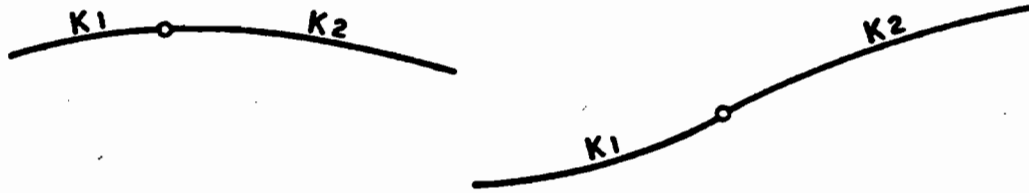

Figure C4-4
Adjacent Vertical Curves

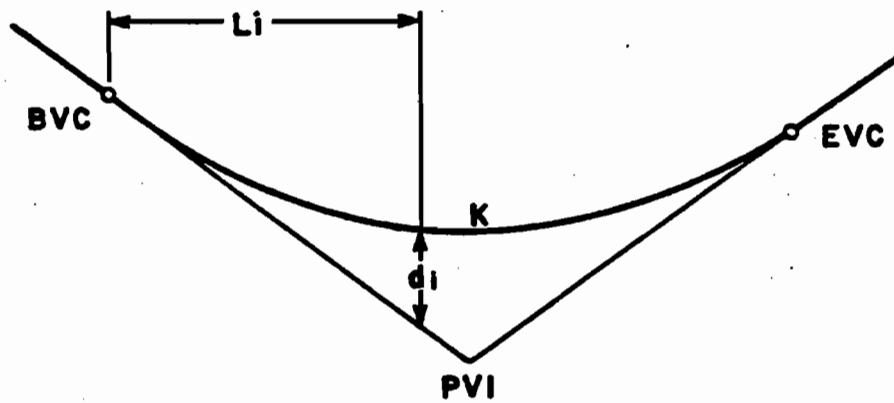

Figure C4-5
Determination of Vertical Curve Elevations

C.4.5 DESIGN PRINCIPLES AND APPLICATION

C.4.5.1 Selection of Elements

In designing vertical alignment the designer should select elements that meet the standards set out in C.4.2 and C.4.3. In general, it is good design to exceed minimum standards as this provides for a safer and usually a more aesthetically pleasing facility, and offers better service to the travelling public. However, higher standards tend to incur higher capital cost and lower standards tend to increase maintenance cost. The objective in design is to arrive at an appropriate blend of safety, service, aesthetic quality and cost.

The design of vertical alignment should not be carried out in isolation but should have a proper relationship with horizontal alignment. This is discussed in Section C.5.

C.4.5.2 Integration of Design Features

Vertical alignment, having a series of successive relatively sharp crest and sag curves giving the impression of a roller coaster, should be avoided even though the minimum values for curvature and grade might be met. Rather, the designer should seek a smooth profile with long vertical curves.

Similarly a vertical alignment in which a short section of roadway is hidden from the driver's view, the so-

called hidden-dip profile, should be avoided. These profiles generally occur on relatively straight horizontal alignment where the roadway profile closely follows a rolling natural ground line. They are aesthetically unpleasant and hazardous. Hidden dips contribute to passing manoeuvre accidents, the passing driver being deceived by the view of the highway beyond the dip free of opposing vehicles. Even with shallow dips this type of profile is disturbing to the driver because he cannot be sure whether there is an oncoming vehicle hidden beyond the rise. This kind of vertical alignment can be avoided by longer and flatter vertical curves, possibly incurring additional cut and fill.

Curves of different K values adjacent to each other without a length of tangent between them as illustrated in Figure C4-4, are acceptable in design provided stopping sight distance requirements are met. Such compound curves in opposite directions are useful where restricted conditions prevail, particularly in urban areas. They would have applications, for example, in overpass and underpass grade separation projects, or urban interchange ramps. Compound curves in the same direction might have an application where it is desirable to maintain vertical curvature over a significant length, although a number of controls, for example, driveway or side-road elevations preclude the application of a single curve. A pair of curves curving in the same direction separated by a short length of tangent is referred to as a broken-back curve and they should be avoided because of their unsatisfactory appearance.

C.4.6 DESIGN TECHNIQUES

C.4.6.1 Mass-Haul Diagram

The mass-haul diagram is a continuous line showing the algebraic sum of earthworks material over a specified length of construction, usually a single design project or single contract. It is a visual tool illustrating the materials movement balance in a diagrammatic form that can be readily understood.

Vertical alignment has an effect on earthworks quantities, earthworks haul distances and type of earth-moving equipment to be used. The mass-haul diagram assists in taking these aspects into account when designing vertical alignment.

The abscissa of the diagram is distance and the ordinate is in units of volume usually cubic metres. The scales can be selected to suit the particular conditions prevailing. It is often convenient to use the same horizontal scale as that used for the profile for simple comparison and direct reference. For the ordinate a scale should be selected to suit the range of earthwork quantities involved.

The volumes shown on the mass-haul diagram represent the algebraic sum, cuts and fills from the beginning of the project. These can be found by listing cuts and fills in a table of algebraic differences, an example of which is shown below:

| Station | Volume m ³ | | Algebraic Sum* of cut and fill |
|---------|-----------------------|---------|-----------------------------------|
| | Cut(+) | Fill(-) | |
| 0+000 | 0 | 0 | 0 |
| 1+000 | 1000 | 500 | + 500 |
| 2+000 | 2000 | 1000 | + 1500 |
| 2+500 | 0 | 1000 | + 500 |
| 3+000 | 100 | 900 | - 300 |
| 4+000 | 0 | 700 | - 1000 |

*Volumes not adjusted to allow for compaction or bulking.

Since compacted earth fill occupies a smaller volume than it does in its natural state, and rock fill occupies a larger volume, adjustment factors for compaction and bulking should be applied.

The column on the left shows stationing. Often this will be an even interval, but not necessarily. The second and third columns show cut and fill to the station shown from the previous station and cut is labelled positive and fill negative. The fourth column shows the algebraic sum of cuts and fills to the station from the beginning. The algebraic sum of cuts and fills are plotted against stationing to give the mass-haul diagram, as illustrated in the sketch.

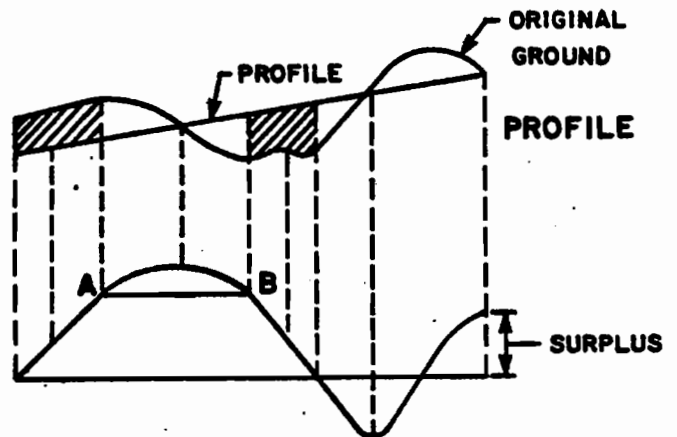

The ordinate at any point on the masshaul diagram represents the accumulated volume to that point from the beginning of the project, cut being regarded as positive and fill negative. At any station where the accumulated volume is above the line there is surplus, and any point below the line there is a deficiency. In cut sections the line is on an upgrade, and in fill sections the line is on a downgrade. Where the line crosses a 0 volume, there is earthworks balance from the beginning to that point on the project.

Any horizontal line that crosses the curve twice, for example, line A-B in the diagram, delineates a local section that is in balance. A crest curve indicates that haul will proceed from left to right, and sag curve indicates that haul will proceed from right to left.

ALIGNMENT

C.5 COORDINATION OF HORIZONTAL AND VERTICAL ALIGNMENT

C.5.1 AESTHETIC CONSIDERATIONS

The visual aspect of the highway as viewed by the motorist should be considered as one of the prime elements in geometric design. The provision of visual comfort will help make driving a more relaxing experience resulting in better and safer traffic operation. Features which are aesthetically disturbing to the motorist should be avoided. An unsightly highway is a blight on the landscape and an aesthetically pleasing facility can become an asset enhancing the area through which it passes.

To produce an aesthetically pleasing facility, the designer should have an appreciation of the relationship between the roadway and its surroundings. Some specific features to be considered include:

- blending of the highway with the surrounding topography;
- developing independent alignments for each roadway of a divided facility when right-of-way permits;
- continuous curvilinear design rather than long tangent, short curve design;
- integration of horizontal and vertical alignment;
- implementation of designs producing visually pleasing structures, retaining walls and landscaping.

In many cases the above principles can be achieved at an acceptable extra cost. In cases where additional cost is a factor, the benefits should be assessed against expenditure.

Example of good and poor application of the above principles are illustrated in Figures C5-1 to C5-9. Each photograph or perspective sketch has a brief comment describing the significant visual qualities.

C.5.2 DESIGN PRINCIPLES

The principal standards for horizontal and vertical alignment are set out in Sections C.2, C.3 and C.4. A section of road might be designed to meet these standards, yet the end result could be a facility exhibiting numerous unsatisfactory or displeasing characteristics. Unfortunately, standards cannot be established for the

HORIZONTAL AND VERTICAL ALIGNMENT

relationship between horizontal and vertical alignment, nor can the subject be dealt with in isolation without reference to the broader subject of highway location. Horizontal and vertical alignments are mutually interrelated and what might be said about one is generally applicable to the other.

In the location stage as well as during the design phase of a facility, one should always try to visualize the finished highway in three dimensions and be aware of the consequences of various combinations of horizontal and vertical alignment on the utility, safety and appearance of the completed project.

To obtain good coordination of horizontal and vertical alignment, the following principles should be used as a guide for engineering study and consideration during the design of a facility:

- curvature and grades should be in proper balance with the terrain and area crossed.
- Superimposing of vertical upon horizontal curvature will generally provide improved appearance. This combination should, however, be analyzed for effect on traffic operations, safety and aesthetics.
- Short vertical curvature should not be introduced on horizontal curves and, when possible, vertical curves should be made long with the mid-points of horizontal and vertical coincident.
- Horizontal curves seen from a distance tend to appear foreshortened and the radius should be made longer to avoid the appearance of a kink.
- On two-lane highways the need for providing adequate safe passing opportunities should not be overlooked. This requirement should supersede and will often limit achievement of some of the other desirable horizontal and vertical alignment combinations.
- On divided highways variable-width medians and use of independent vertical and horizontal alignments for each direction should be considered where such combinations would be of design or operational advantage.
- It should be remembered that horizontal and vertical alignments are the most permanent design elements of a highway, and once a facility is constructed, poorly designed combinations will, in all likelihood, remain in operation and be viewed by road users for many years.



To more fully appreciate the value of good design, it is instructive to observe a few examples of discontinuous alignment where "how it looks" was considered unimportant. A continuous curve, beginning at the bottom of the picture and ending where the right lane disappears, would have been a much superior design.



These contrasting photographs illustrate vividly the difference between long tangent-short curve design vs continuous curvilinear alignment. The top view gives one the impression the designer laid out each segment of highway on a separate sheet of plan paper without regard to the continuity of the entire roadway. The other highway (bottom) flows with the natural contours of the terrain with a minimum of sudden change in alignment or grade.

Figure C5-1

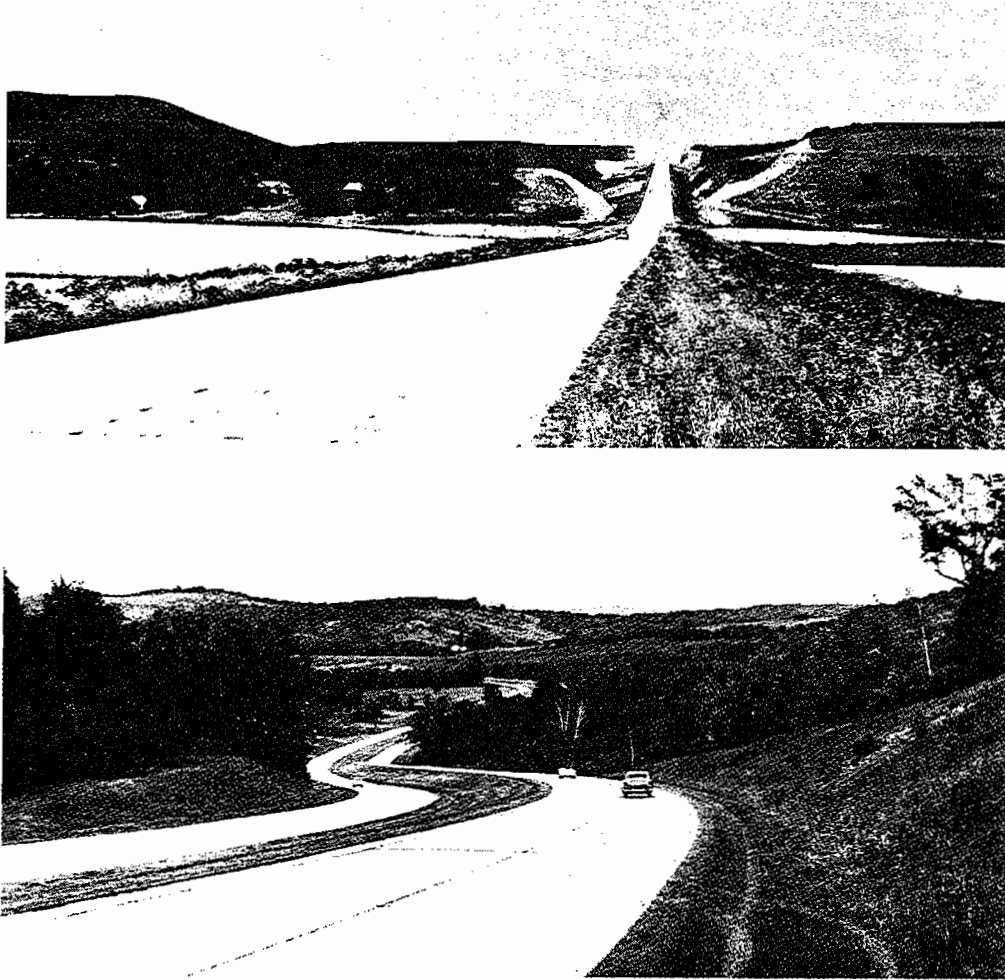

Alignment should be as directional as possible, but should be consistent with the topography. A flowing line that generally conforms to the natural contours is aesthetically preferable to one with long tangents that slashes through the terrain. The construction scars can be kept to a minimum and natural slopes and plant growth can be preserved.

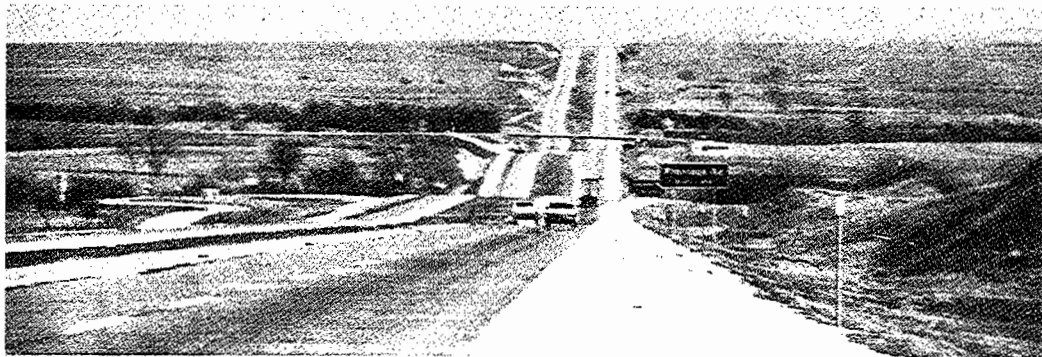

Because of straight alignment, one can often see a long distance ahead. When this happens, it is almost impossible to avoid a roller-coaster appearance. Also, any median width changes are difficult to conceal. Observe the width change just above the grade separation structure.

Figure C5-2

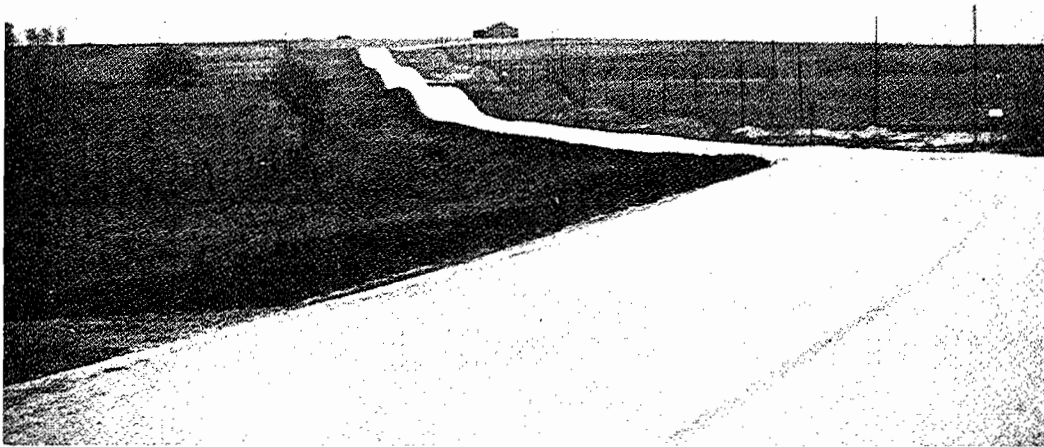

The 'roller-coaster' or the 'hidden-dip' type of profile should be avoided. In general, such profiles occur on relatively straight, horizontal alignment where the roadway profile closely follows a rolling natural ground line. They are unpleasant aesthetically and hazardous.

The vertical alignment, which attempts to match the rather minor "humps and hollows," is not in scale with the more liberal horizontal alignment.

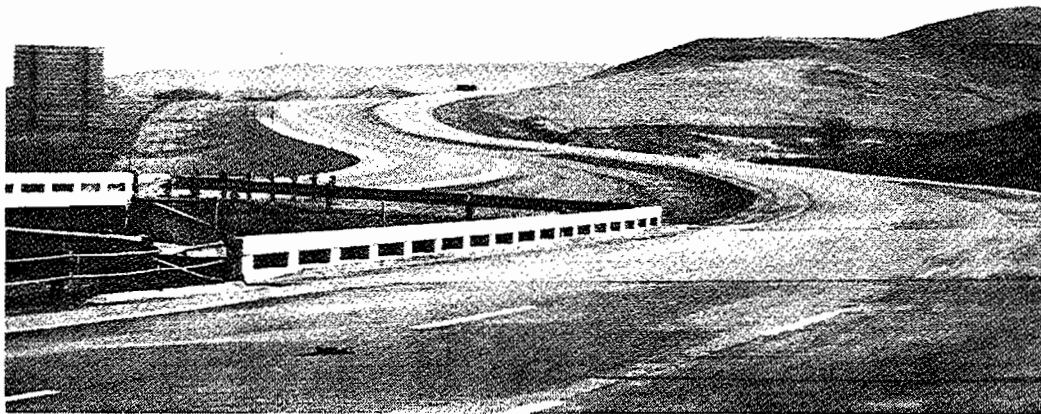

This example of curvilinear alignment enables the driver to scan the surrounding landscape without turning his head for a better view.

Figure C5-3

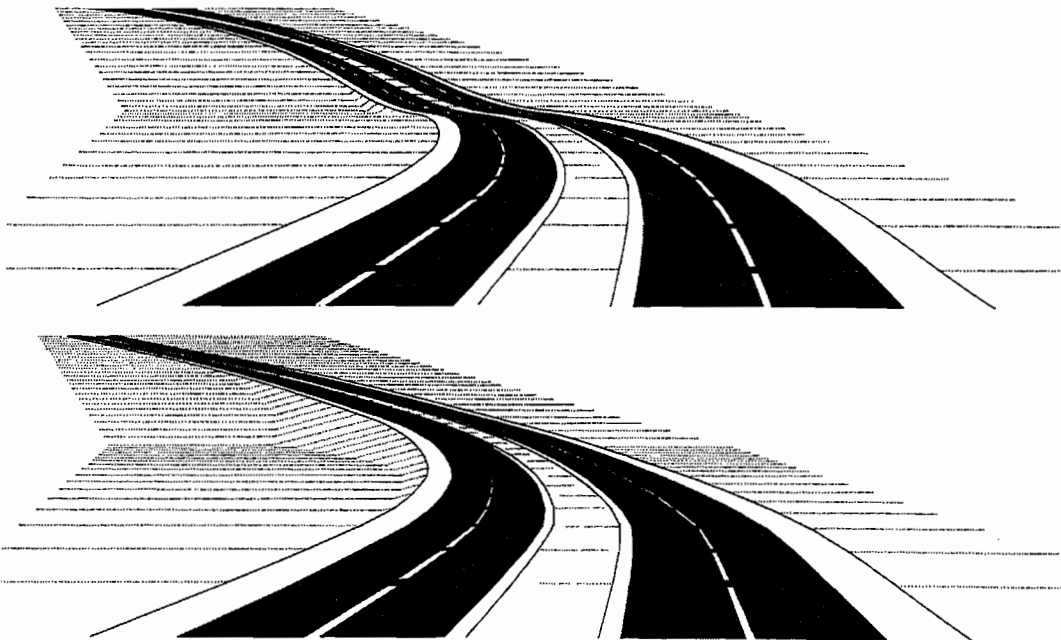

This drawing illustrates the effect of superimposing a short vertical curve on a relatively long horizontal curve. To eliminate the appearance of a settlement of the roadway, it is necessary to increase the length of vertical curve to that nearly of the horizontal curve.



The sagging effect is clearly evident in this picture.

Figure C5-4

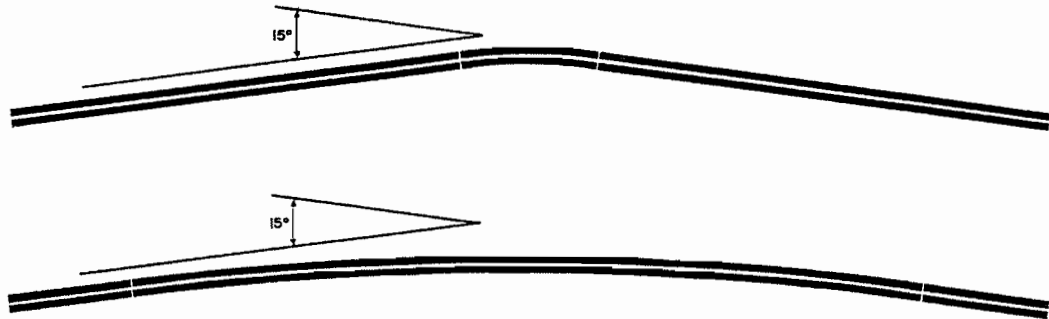

For small deflection angles, curves should be sufficiently long to avoid the appearance of a kink.



This view gives the feeling that the designer changed his mind rather suddenly and did not plan very far ahead. To avoid this, the length of curve should be proportional to the maximum distance from which one views the curve.

Figure C5-5



The horizontal curve does not appear to be tangent to the straight alignment. In fact, it visually jerks away from the tangent alignment. The left-hand roadway does, however, give the driver a good "clue" that the road continues to the left and does not merely "fade away".

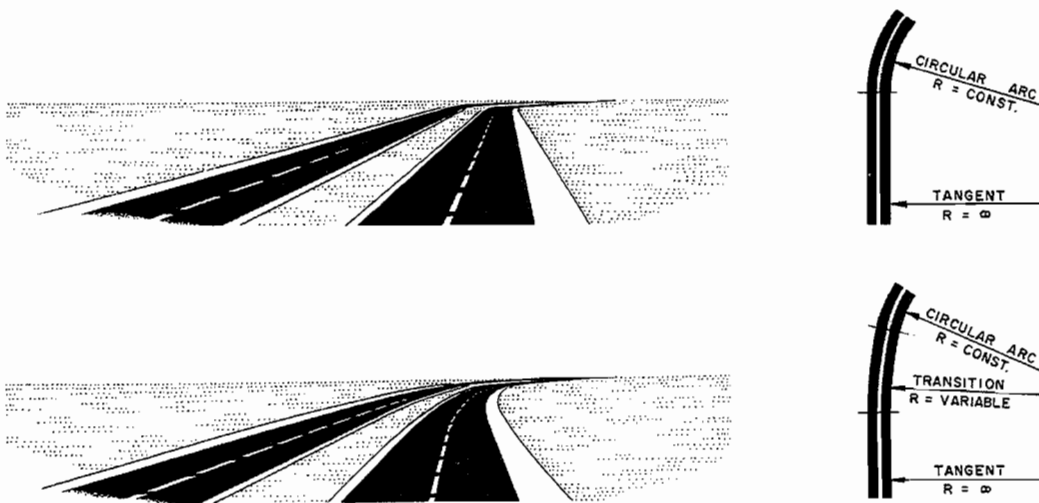

One effect of perspective viewing is that distant objects seem nearer than they really are. The circular curve consequently appears to diverge from the tangent rather rapidly and the curve no longer seems continuous. This gives the impression the designer was unable to make the curve meet the tangent properly. To remedy this situation, the use of long spirals is suggested and is illustrated in the upper picture.

Figure C5-6

ALIGNMENT

HORIZONTAL AND VERTICAL ALIGNMENT

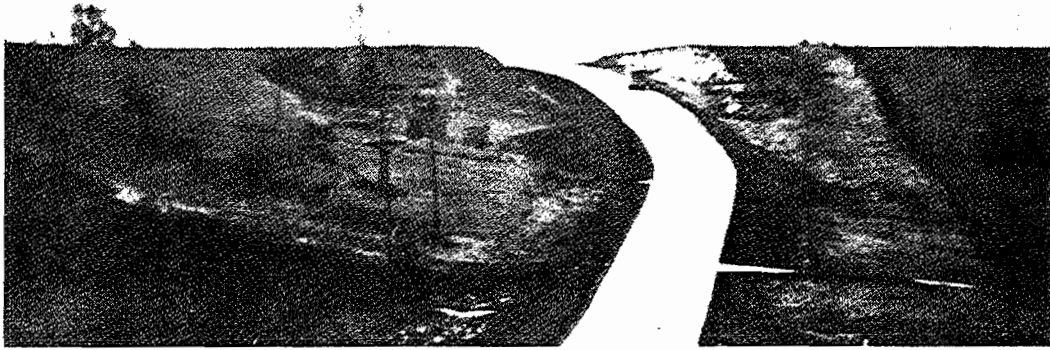

A long spiral beginning at the first entrance at the bottom of the hill and ending near the position of the truck would have improved the appearance of this curve.

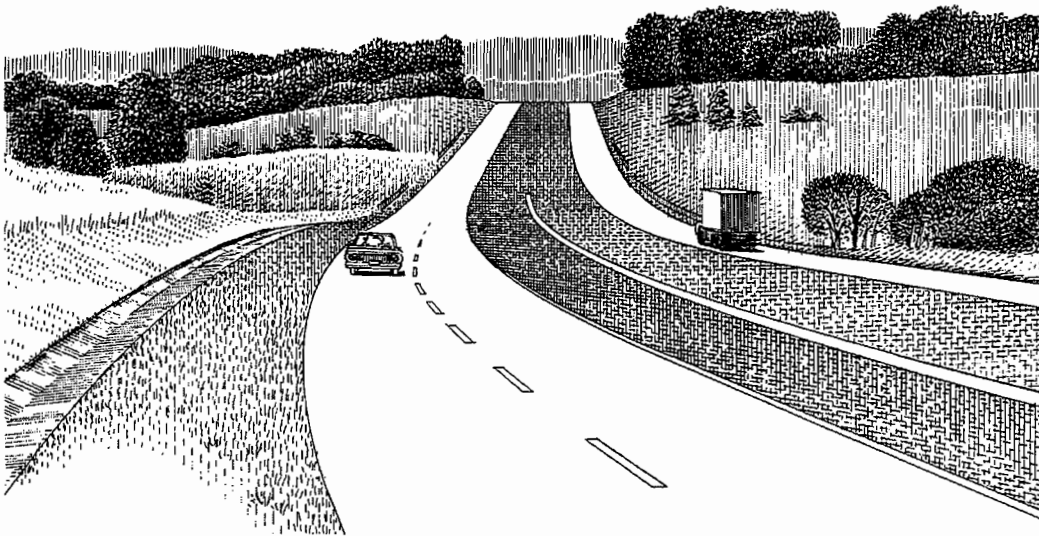
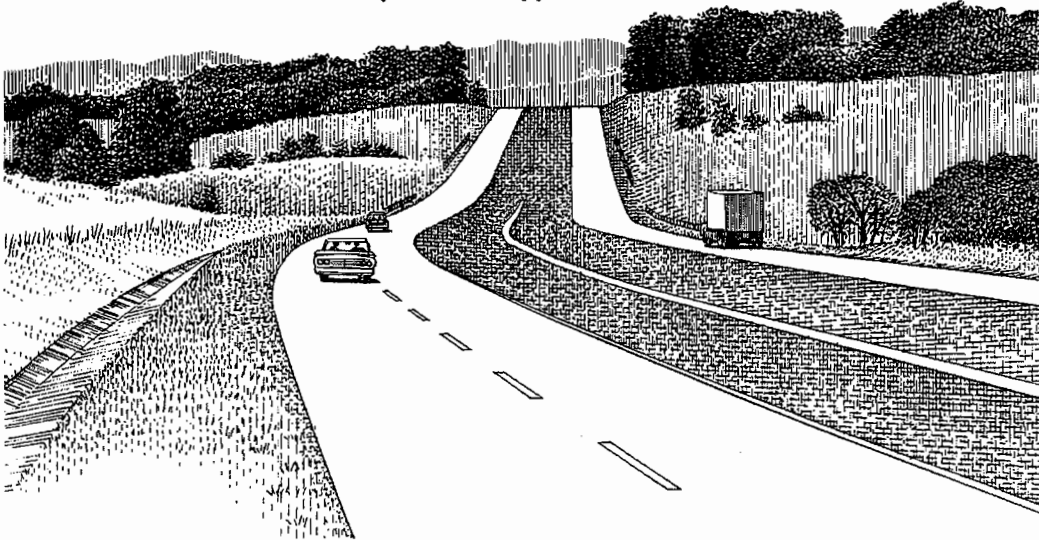

Short vertical curvature at the end of a long horizontal curve will usually produce a warped appearance. This situation can be improved by using a longer vertical curve than otherwise would be needed.

Figure C5-7

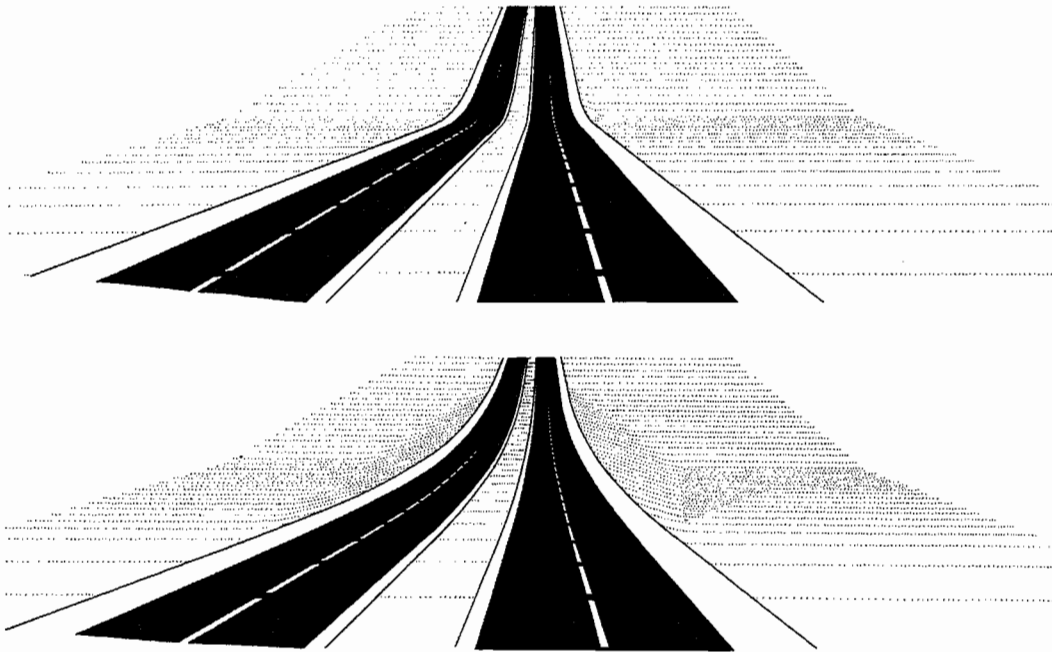

When the relatively-short vertical curve in the upper picture is viewed from some distance, the transition from downgrade to upgrade appears rather abrupt. The alternatives to this design are longer curves and/or curvilinear alignment to shorten the "long look" ahead.



The broken-back vertical alignment with small grade changes. This type of design destroys the flowing continuity of a high-speed highway. Note the jerk in horizontal alignment.

Figure C5-8

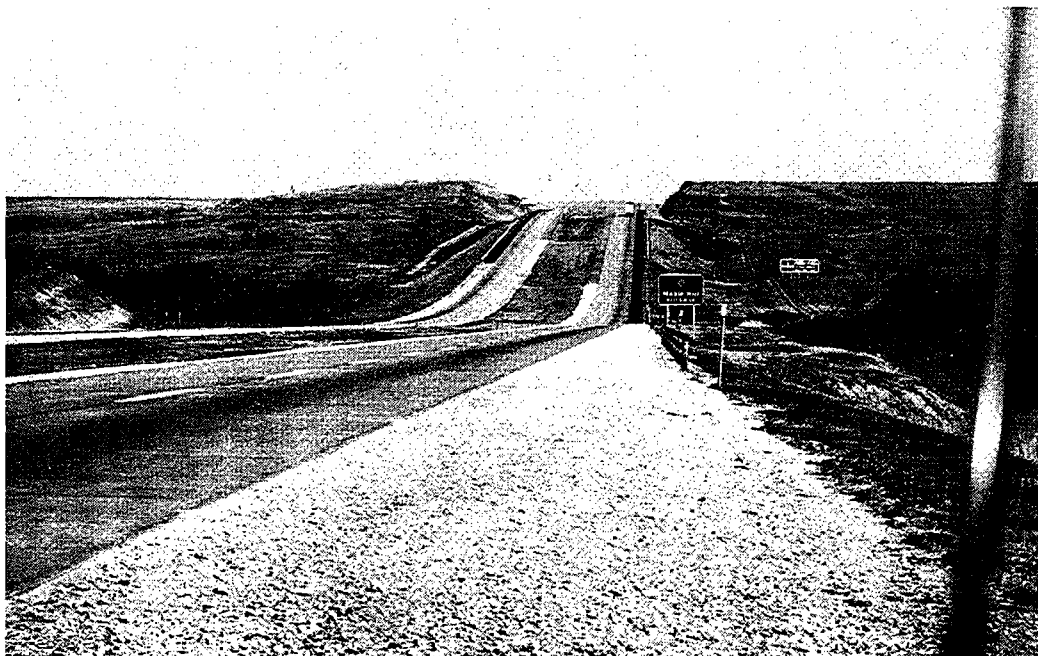

From an intermediate point, the curve is only a little too short.



From this position, the length of vertical curve is about right.

Figure C5-9

C.6 DESIGN AIDS

C.6.1 TEMPLATES

C.6.1.1 Horizontal Curve Templates

Metric circular curve templates are made of clear, semi-rigid plastic and the complete set consists of 102 pieces. The templates are marked with the radii for five standard scales, namely 1:200, 1:500, 1:1,000, 1:2,000, 1:5,000. The set provides for 77 standard radii. The 11 templates for the smallest radii are complete circles and the remaining 91 templates are segments. Radii for each scale are shown on each template unless the value is not a standard one. Templates are graduated on the edge at intervals of 50 m at the scale of 1:1,000.

The range of scales of the semi-rigid horizontal alignment templates from 1:200 to 1:5,000 provides for application to a wide range of highway engineering work from feasibility studies, route location, functional planning, preliminary design to detailed design.

C.6.1.2 Vertical Curve Templates

Vertical curve templates of parabolic form are made of clear, semi-rigid plastic and a complete set consists of 37 pieces. The vertical scale to the horizontal scale has a ratio of 10:1 and the templates are marked for five horizontal scales 1:200, 1:500, 1:1,000, 1:2,000, 1:5,000. K values for each scale are shown on each template, unless the value is not a standard one. Each template has a vertical and horizontal line to orient the template correctly on profile paper. Templates are graduated at horizontal intervals of 100 m at a scale of 1:1,000. The change of grade between successive graduations is 1%.

The vertical curve templates can be used for all phases of highway engineering work from feasibility studies through route location, functional planning, predesign to detailed design.

C.6.1.3 Sight Distance Templates and Their Application

Sight distance templates are used for measuring stopping and passing sight distances on profiles. They are made of transparent film in an overlay strip form at scales of 1:1,000 horizontally and 1:100 vertically and 1:2,000 horizontally and 1:200 vertically.

Each template consists of four parallel horizontal lines, the top line representing the line of sight and the lower three lines representing profile elevations at the object for stopping sight distance the opposing vehicle for passing sight distance and the height of the driver's eye, using the standard dimensions described in Section C.4.3.4 and Section C.4.3.6.

To determine graphically the sight distances on the plan and profile refer to Figure C6-1.

Horizontal sight distance on the inside of a curve may be limited by obstructions such as buildings, hedges, wooded areas, cut slope, or other topographic features or on the outside of the curve by a median barrier wall. The sight distance is measured with a straight edge, as indicated at the upper left in the plan diagram of Figure C6-1. The height of sight line for locating the cut slope is derived as follows:

- for stopping sight distance by averaging the height of driver's eye and height of object.
- for passing sight distance, the height of driver's eye.

The stopping sight distance should be measured between points on the one traffic lane, and passing sight distance from the middle of one lane to the middle of the other.

Vertical sight distance may be scaled from a plotted profile as illustrated in the sketch of Figure C6-1, so that the upper line of the sight distance template is tangential with a crest curve. The location of the intersection of the other lines with the profile represents the position of the driver's eye, opposing vehicle or object, as the case may be. The available stopping sight distance and passing sight distance on crest curves can then be read directly.

These templates are particularly useful for checking stopping and passing sight distance available on existing roads and during design when a profile is being splined. The templates also have an application in sag curvature where the comfort criterion is adopted as a basis for design. The third line from the top may be placed on the pavement, and top line representing the line of vision passed through the corner of a potential obstruction, for example, the underside of an underpass structure. The distance from the driver's eye to the location where the line of sight intersects the profile, represents available stopping sight distance.

C.6.1.4 Design Vehicle Turning Templates

Design vehicle turning templates are used as design aid to establish controls for the layout of the edge of pavement curves at simple open throat intersections.

Refer to section E.5 and E.6 for information.

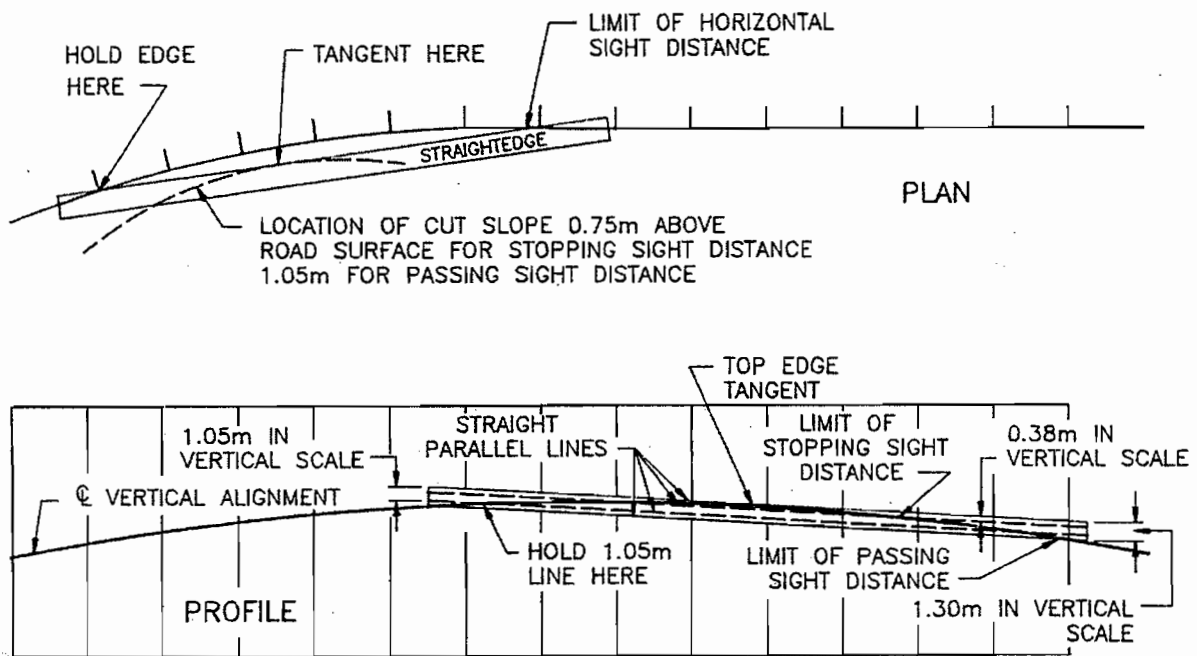

Figure C6-1
Typical Plan and Profile to Determine the Sight Distances Graphically

C.6.2 TABLES**C.6.2.1 Horizontal Alignment**

The publication 'Metric Curve Tables - Circular and Spiral Curve Functions for Layout Purposes' was prepared by the Ministry primarily for the purpose of facilitating field layout work. In addition, some of the tables are useful in planning and design.

Table I is for circular curves. For standard radii it gives deflection angles for arcs of 1 m, 10 m, 20 m, 25 m, and 50 m. The table also gives chord length for arcs of 10 m, 20 m, 25 m and 50 m, and deflection angles for chords of 10 m, 20 m, 25 m and 50 m. Table 1 covers radii from 45 m to 10,000 m.

Table IA gives the same properties as Table 1, but instead of using standard rational radii, the properties are for circular curves designated by degree of curvature. This table has an application for existing roads which were designed using the degree of curvature designation for circular curves.

Table II gives properties of circular curves, namely, tangent, external and length for a curve of 100 m radius and a range of deflection angles from 1' to 123° 20'. This table is used to find properties for other radii by multiplying the property by the particular radius and dividing by 100.

Table III gives functions of the unit radius spiral. This table is used by entering with the ratio A/R or L_s/A and each property of the spiral is given in terms of the unit radius. These values are multiplied by the end radius of the particular spiral.

Table IV gives functions of standard spirals from $A = 25$ m to $A = 1,700$ m. For each standard spiral and for a selected range of radii, tables give A/R and the properties of the spiral directly.

Table Va and Vb give superelevation and spiral parameter requirements for design speed against radius. This information is the same as that of Tables C3-3 and C3-4.

Table VI gives spiral constants K for a range of standard parameters in three forms: degrees, minutes and seconds. This value may be used to determine deflection angle from the beginning of a spiral to any point on the spiral. The deflection angle is equal to K multiplied by the square of the distance measured along the spiral from the beginning of the spiral, reduced by the correction angle given by Table III.

Examples of the application of Tables I, IA, II, III, IV and VI follow.

C.6.2.2 Vertical Alignment

'Vertical Curve Tables' published by the Design and Construction Branch gives ordinates of parabolic curves. For 16 standard K values ranging from 35 to 300 the ordinates between the tangent and the curve may be read off directly by entering in the distance from the beginning of the curve and reading opposite the appropriate K value. The ordinates of a curve of any other K value can be obtained from the same tables by adjusting the ordinate values of a given curve in the ratio of the K values. If the algebraic difference in grades and K values are given, the length of curve may be calculated. If it is then rounded to some convenient value (usually to the nearest metre), the effect is to slightly change the K value. If ordinates are then read from the vertical curve tables, it should be noted that there will be minor errors in the ordinate which might be of negligible significance.

Example from Table I:

For R = 280 m

| <u>for arc of</u> | <u>deflection angle</u> |
|-------------------|-------------------------|
| 1 m | 6.1388' |
| 10 m | 1° 1' 23.30" |
| 20 m | 2° 2' 46.60" |
| 25 m | 2° 33' 28.25" |
| 50 m | 5° 6' 56.50" |

| <u>for arc of</u> | <u>chord length</u> |
|-------------------|---------------------|
| 10 m | .9995 m |
| 20 m | 19.9957 m |
| 25 m | 24.9917 m |
| 50 m | 49.9336 m |

| <u>for chord of</u> | <u>deflection angle</u> |
|---------------------|-------------------------|
| 10 m | 1° 1' 23.50" |
| 20 m | 2° 2' 48.17" |
| 25 m | 2° 33' 31.31" |
| 50 m | 5° 7' 21.06" |

Example from Table IA:

For curvature D = 12° (100' arc definition)
R = 145.5313

| <u>for arc of</u> | <u>deflection angle</u> |
|-------------------|-------------------------|
| 1 m | 11.8110' |
| 10 m | 1° 58' 6.61" |
| 20 m | 3° 56' 13.23" |
| 25 m | 4° 55' 16.54" |
| 50 m | 9° 50' 33.07" |

| <u>for chord of</u> | <u>chord length</u> |
|---------------------|---------------------|
| 10 m | 9.9980 m |
| 20 m | 19.9843 m |
| 25 m | 24.9693 m |
| 50 m | 49.7544 m |

| <u>for chord of</u> | <u>deflection angle</u> |
|---------------------|-------------------------|
| 10 m | 1° 58' 8.01' |
| 20 m | 3° 56' 24.41' |
| 25 m | 4° 55' 38.39' |
| 50 m | 9° 53' 29.70' |

Example from Table II:

$$\text{For } R = 650 \text{ m}$$

$$\text{Deflection angle} = 32^\circ$$

$$\text{Tangent} = 28.67454 \times \frac{650}{100} \text{ m} = 186.38451 \text{ m}$$

$$\text{External} = 4.02994 \times \frac{650}{100} \text{ m} = 26.19461 \text{ m}$$

$$\text{Arc Length} = 55.85054 \times \frac{650}{100} \text{ m} = 363.02851 \text{ m}$$

Example from Table III:

$$A = 225 \text{ m}$$

$$\text{End radius} = 900 \text{ m}$$

$$A/R = 0.25000$$

$$L_s = 0.06250000 \times 900 \text{ m} = 56.2500 \text{ m}$$

$$X = 0.06249390 \times 900 \text{ m} = 56.2445 \text{ m}$$

$$Y = 0.00065100 \times 900 \text{ m} = 0.5859 \text{ m}$$

$$q = 0.03124898 \times 900 \text{ m} = 28.1241 \text{ m}$$

$$p = 0.00016275 \times 900 \text{ m} = 0.1465 \text{ m}$$

$$T_L = 0.04166880 \times 900 \text{ m} = 37.5019 \text{ m}$$

$$T_s = 0.02083527 \times 900 \text{ m} = 18.7517 \text{ m}$$

$$L_c = 0.06249729 \times 900 \text{ m} = 56.2476 \text{ m}$$

$$\theta = 1^\circ 47' 25.8''$$

$$C = 0^\circ 0' 00''$$

$$\phi = 0^\circ 35' 48.6''$$

Example from Table IV:

$$A = 170 \text{ m}$$

$$R = 250 \text{ m}$$

$$A/R = 0.6800$$

$$L_s = 115.600 \text{ m}$$

$$X = 114.984 \text{ m}$$

$$Y = 8.875 \text{ m}$$

$$q = 57.697 \text{ m}$$

$$p = 2.223 \text{ m}$$

$$T_L = 77.284 \text{ m}$$

$$T_s = 38.731 \text{ m}$$

$$L_c = 115.326 \text{ m}$$

$$\theta = 13^\circ 14' 48.4''$$

$$\phi = 4^\circ 24' 48.9''$$

Example from Table VI:

$$A = 140 \text{ m}$$

$$K = 0.00048721^\circ$$

If λ is the distance from the beginning of a spiral to a given point, the spiral deflection angle to the point is given by:

$$\phi_\lambda = K\lambda^2 - C_\lambda$$

$$\text{If } \lambda = 50 \text{ m}$$

$$\phi_\lambda = (0.00048721 \times 50^2)^\circ - (0^\circ 0' 0.2'')$$

$$\phi_\lambda = 1^\circ 13' 04.7''$$

C may be found from Table III for the ratio λ/A (LS/A).

**C.6.3 COMPUTER PROGRAMS (HIGHWAY
DESIGN SYSTEMS)**

Information regarding specific systems/programs applicable to "Geometrics" (horizontal and vertical alignments), may be obtained through the

Manager,
Automated Systems Section
Surveys and Design Office
Transportation Engineering and Standards Branch
Ministry of Transportation
1201 Wilson Avenue,
Downsview, Ontario,
M3M 1J8.

CHAPTER D

CROSS SECTION

ELEMENTS

CHAPTER D
CROSS SECTION ELEMENTS

CONTENTS

| | |
|---|-------------|
| D.1 INTRODUCTION | D1-1 |
| D.1.1 NOMENCLATURE | D1-1 |
| D.1.2 STAGE CONSTRUCTION | D1-4 |
| D.1.3 DIMENSIONING | D1-4 |
| | |
| D.2 LANE WIDTHS | D2-1 |
| D.2.1 INTRODUCTION | D2-1 |
| D.2.2 THROUGH LANES | D2-1 |
| D.2.3 AUXILIARY LANES | D2-4 |
| D.2.4 RAMPS AND TRANSFER LANES | D2-6 |
| D.2.5 PARKING LANES | D2-6 |
| D.2.6 BUS BAYS | D2-6 |
| D.2.7 SUMMARY | D2-6 |
| | |
| D.3 PAVEMENT WIDENING ON CURVES | D3-1 |
| D.3.1 BASIS OF DESIGN | D3-1 |
| D.3.2 DESIGN VALUES | D3-1 |
| D.3.3 WARRANTS | D3-5 |
| D.3.3.1 UNDIVIDED ROADWAYS | D3-5 |
| D.3.3.2 DIVIDED HIGHWAYS | D3-5 |
| D.3.3.3 RAMPS | D3-5 |
| D.3.4 APPLICATION | D3-5 |
| | |
| D.4 PAVEMENT CROSS-FALL AND SUPERELEVATION | D4-1 |
| D.4.1 CROSSFALL REQUIREMENTS | D4-1 |
| D.4.2 SUPERELEVATION REQUIREMENTS | D4-3 |
| D.4.3 APPLICATION OF SUPERELEVATION | D4-4 |
| D.4.3.1 Rate of Change | D4-4 |
| D.4.3.2 Difference in Pavement Crossfall | D4-4 |
| D.4.3.3 Undivided Roadways | D4-4 |
| D.4.3.4 Divided Roadways | D4-8 |
| D.4.3.5 Cross-Fall and Superelevation for Resurfacing Projects | D4-8 |

CHAPTER D
CROSS SECTION ELEMENTS

CONTENTS

| | | |
|----------------|---|--------------|
| D.5 | SHOULDERS | D5-1 |
| D.5.1 | FUNCTION | D5-1 |
| D.5.2 | TREATMENT OF SURFACE | D5-1 |
| D.5.2.1 | Partially Paved Shoulders | D5-1 |
| D.5.2.2 | Fully Paved Shoulders | D5-2 |
| D.5.3 | WIDTH | D5-2 |
| D.5.4 | CROSS-FALL AND SUPERELEVATION | D5-3 |
| D.5.5 | SHOULDER ROUNDING | D5-7 |
| D.5.6 | GUIDELINES FOR SHOULDER DESIGN ON RESURFACING PROJECTS | D5-8 |
| | | |
| D.6 | MEDIANS | D6-1 |
| D.6.1 | GENERAL | D6-1 |
| D.6.2 | FREEWAYS | D6-1 |
| D.6.2.1 | Rural Freeways | D6-1 |
| D.6.2.2 | Staged Freeway Construction | D6-2 |
| D.6.2.3 | Urban Freeways | D6-3 |
| D.6.2.4 | Outer Separations | D6-7 |
| D.6.3 | ARTERIAL HIGHWAYS | D6-8 |
| D.6.3.1 | Rural Arterials | D6-8 |
| D.6.3.2 | Urban Arterials | D6-10 |
| D.6.4 | MEDIAN CROSSOVERS | D6-11 |
| | | |
| D.7 | STRUCTURES AND CLEARANCES | D7-1 |
| D.7.1 | GENERAL | D7-1 |
| | | |
| D.8 | OFF-ROADWAY ELEMENTS | D8-1 |
| D.8.1 | CURB AND GUTTER | D8-1 |
| D.8.2 | TRAFFIC BARRIERS | D8-1 |
| D.8.3 | CRASH CUSHIONS | D8-3 |
| D.8.4 | BOULEVARDS AND SIDEWALKS | D8-3 |
| D.8.5 | ROADSIDE APPURTENANCES | D8-4 |
| D.8.6 | NOISE ATTENUATION | D8-4 |

CHAPTER D
CROSS SECTION ELEMENTS

CONTENTS

| | |
|--|--------------|
| D.9 GRADING AND DRAINAGE CHANNELS | D9-1 |
| D.9.1 SLOPES | D9-1 |
| D.9.2 SNOW IMPACT | D9-1 |
| D.9.2.1 Mitigating Measures | D9-1 |
| D.9.3 CONTOUR DESIGN | D9-2 |
| D.9.4 DRAINAGE CHANNELS | D9-2 |
| | |
| D.10 RIGHT-OF-WAY | D10-1 |
| D.10.1 CRITERIA | D10-1 |
| D.10.2 SELECTION | D10-1 |
| | |
| APPENDIX | DA-1 |
| SUMMARY OF GEOMETRIC DESIGN STANDARDS | DA-1 |

CHAPTER D

CROSS SECTION ELEMENTS

TABLES

| | | |
|------|--|------|
| D2-1 | Lane Width for 2-Lane Rural King's Highways | D2-2 |
| D2-2 | Lane Width for Secondary Highways | D2-2 |
| D2-3 | Lane Width for Undivided and Divided Highways | D2-3 |
| D2-4 | Lane Width for Undivided Urban Roads | D2-3 |
| D2-5 | Auxiliary Lane Widths. | D2-5 |
| D3-1 | Pavement Widening Values on Curves for Single Unit (SU) Vehicles | D3-2 |
| D3-2 | Pavement Widening on Curves for Tractor-Semi-Trailer (WB-15) Vehicles | D3-3 |
| D3-3 | Pavement Widening on Curves for Tractor-Semi-Trailer (WB-17.5) Vehicles | D3-4 |
| D4-1 | Maximum Relative Slope Between Outer Edge of Pavement and Centreline for 2-Lane Roadway | D4-5 |
| D4-2 | Design Values for Rate of Change of Cross-Fall for Single Lane Turning Roadways | D4-5 |
| D4-3 | Maximum Algebraic Difference in Pavement Cross-Fall at Turning Roadway Terminals | D4-7 |
| D4-4 | Pavement Cross-Fall for Resurfacing Projects | D4-9 |
| D5-1 | Shoulder Width for Undivided King's Highways and Secondary Highways | D5-4 |
| D5-2 | Superelevation for Shoulders on High Side of Superelevated Sections | D5-5 |
| DA-1 | Geometric Design Standards for Rural King's Highways | DA-2 |
| DA-2 | Geometric Design Standards for Secondary Highways | DA-3 |
| DA-3 | Geometric Design Standards for Undivided Urban Roads | DA-4 |

CHAPTER D

CROSS SECTION ELEMENTS

FIGURES

| | | |
|------|---|-------|
| D1-1 | Nomenclature for Rural Road Cross Section Elements | D1-2 |
| D1-2 | Nomenclature for Urban Road Cross Section Elements | D1-3 |
| D2-1 | Parallel Parking Dimensions | D2-7 |
| D2-2 | Angle Parking Dimensions | D2-7 |
| D3-1 | Basis for Pavement Widening | D3-1 |
| D4-1 | Application of 2% Cross-Fall on Tangent Section | D4-2 |
| D4-2 | Development of Superelevation at Turning Roadway Exit Terminals | D4-6 |
| D4-3 | Application of Superelevation on Divided Roadways | D4-10 |
| D5-1 | Unpaved Shoulder Cross-Fall | D5-5 |
| D5-2 | Partially Paved Shoulder Cross-Fall. | D5-5 |
| D5-3 | Paved Shoulder Cross-Fall. | D5-6 |
| D5-4 | Paved Shoulder Cross-Fall Superelevated Section - Urban Ramp. | D5-6 |
| D5-5 | Shoulder Rounding | D5-7 |
| D5-6 | Shoulder Treatment on Resurfacing Projects | D5-8 |
| D6-1 | Median Width for Rural Freeways | D6-2 |
| D6-2 | Stage Construction for Freeway Medians | D6-2 |
| D6-3 | Urban Freeway Flush Median Treatment | D6-4 |
| D6-4 | Urban Freeway Flush or Raised Median Treatment with Steel Beam Barrier with or without Bridge Piers | D6-6 |
| D6-5 | Outer Separation Treatment | D6-7 |
| D6-6 | Rural Arterial Flush or Raised Median Treatment | D6-9 |
| D6-7 | Urban and Rural Arterial Flush Median Treatment with Median Concrete Barrier with or without Bridge Piers | D6-10 |
| D6-8 | Urban Arterial Raised Median Treatment | D6-11 |
| D6-9 | Urban Arterial Flush or Raised Median Treatment with Steel Beam Barrier at Bridge Pier | D6-12 |
| D8-1 | Concrete Curb and Gutter Dimensions | D8-2 |

D.1 INTRODUCTION**D.1.1 NOMENCLATURE**

The cross section of a road is the view of a vertical plane perpendicular to the horizontal alignment. It is normally illustrated in the direction of increasing stationing. Only the visible cross section elements are dealt with in this chapter. Non-visible dimensions, such as depths of asphalt and granular base are geotechnical matters and are beyond the scope of this manual. The elements of cross section described in the following paragraphs are illustrated in Figures D1-1 and D1-2.

The term *road* refers to the right-of-way or strip of land reserved for public travel.

The term *roadway* refers to those elements intended for vehicular use, including the shoulders.

Travelled way refers to that part of a roadway intended for vehicular use excluding shoulders. It may have a variety of surfaces but is most commonly hard surfaced with asphalt or concrete or gravel surfaced.

Traffic lane is a through lane or auxiliary lane for the movement of a single line of vehicles.

Through lanes are those lanes intended for normal through travel of vehicles.

Auxiliary lanes are lanes in addition to and placed adjacent to through lanes, intended for specific manoeuvres such as turning, merging, diverging and weaving, or to accommodate slow-moving vehicles, but not parking.

Shoulders are areas of pavement, gravel or hard surface placed adjacent to through or auxiliary lanes. They are intended for emergency stopping and travel by emergency vehicles only. They also provide structural support for the pavement.

A *median* is the area that laterally separates traffic lanes carrying traffic in opposite directions. A median is described as flush, raised or depressed, referring to the general elevation of the median in relation to the adjacent edges of traffic lanes. The terms wide and narrow are often used to distinguish different types of median. A wide median generally refers to depressed medians sufficiently wide to drain the base and subbase into a median drainage channel. Flush and raised medians are usually narrow medians.

An *outer separation* is a reserve which separates traffic travelling in the same direction, and includes shoulders, if any.

A *sidewalk* is a travelled way intended for use by pedestrians only, and normally follows an alignment generally parallel to that of the adjacent roadway.

A *bikeway* is that part of a right-of-way set aside for the preferential treatment of bicycle traffic and is made up of one or more bicycle lanes.

A *boulevard* is a reserve which separates the roadway and sidewalk. It provides some protection to the pedestrian and can accommodate street accessories such as traffic signs and fire hydrants. It is a suitable location for underground utilities and may be used for illumination poles. It also provides 'an area' for snow storage.

Curb and gutter is placed adjacent to an outside lane or shoulder and is intended to control and conduct storm-water and also provides delineation for traffic. In some instances, curb is introduced without a gutter.

A *drainage channel* is placed adjacent to an outside lane or shoulder and is intended to control and conduct storm-water runoff. A shallow drainage channel is sometimes referred to as a *swale*.

A roadway located above the natural ground elevation is said to be in fill, and a roadway located below natural ground elevation is said to be in cut. Where the roadway is in fill, the slope between the roadway and the natural ground is referred to as the *fill side slope* or sometimes the *fill slope*. Where the roadway is in cut there is normally a drainage channel adjacent to the roadway. The slope between the roadway and channel is referred to as a *cut side slope* and the slope between the channel and the natural ground is referred to as a *back slope*.

Traffic barriers are placed adjacent to a roadway to protect traffic from hazardous objects either fixed or moving (other traffic).

Traffic barriers placed in a median are referred to as *median barriers* and may be placed in flush, raised or depressed medians.

Two-lane roads and *four-lane* roads have one and two through lanes of traffic in each direction respectively.

Multi-lane roads have more than two through lanes of traffic in each direction.

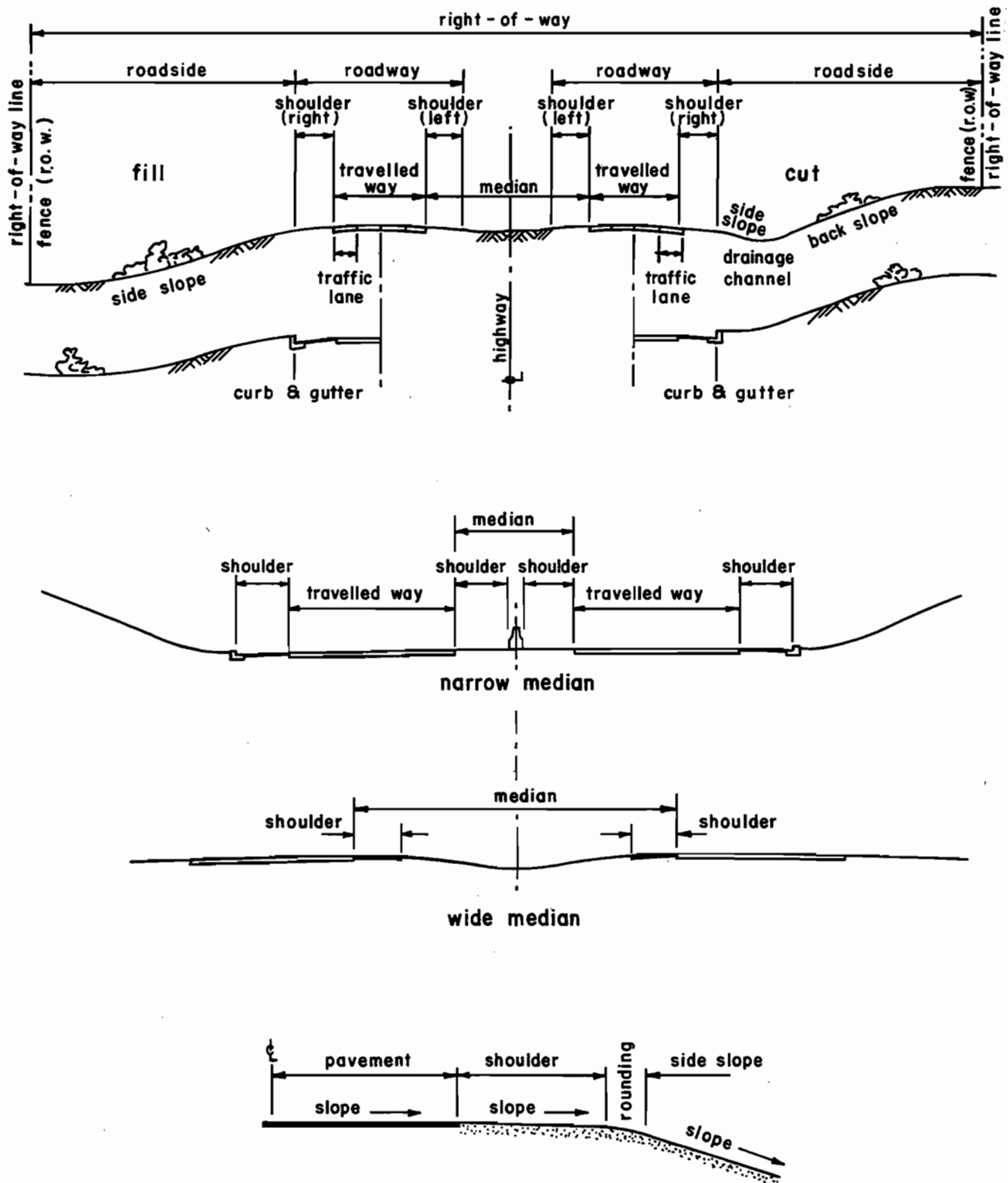

Figure D1-1

Nomenclature for Rural Road Cross Section Elements

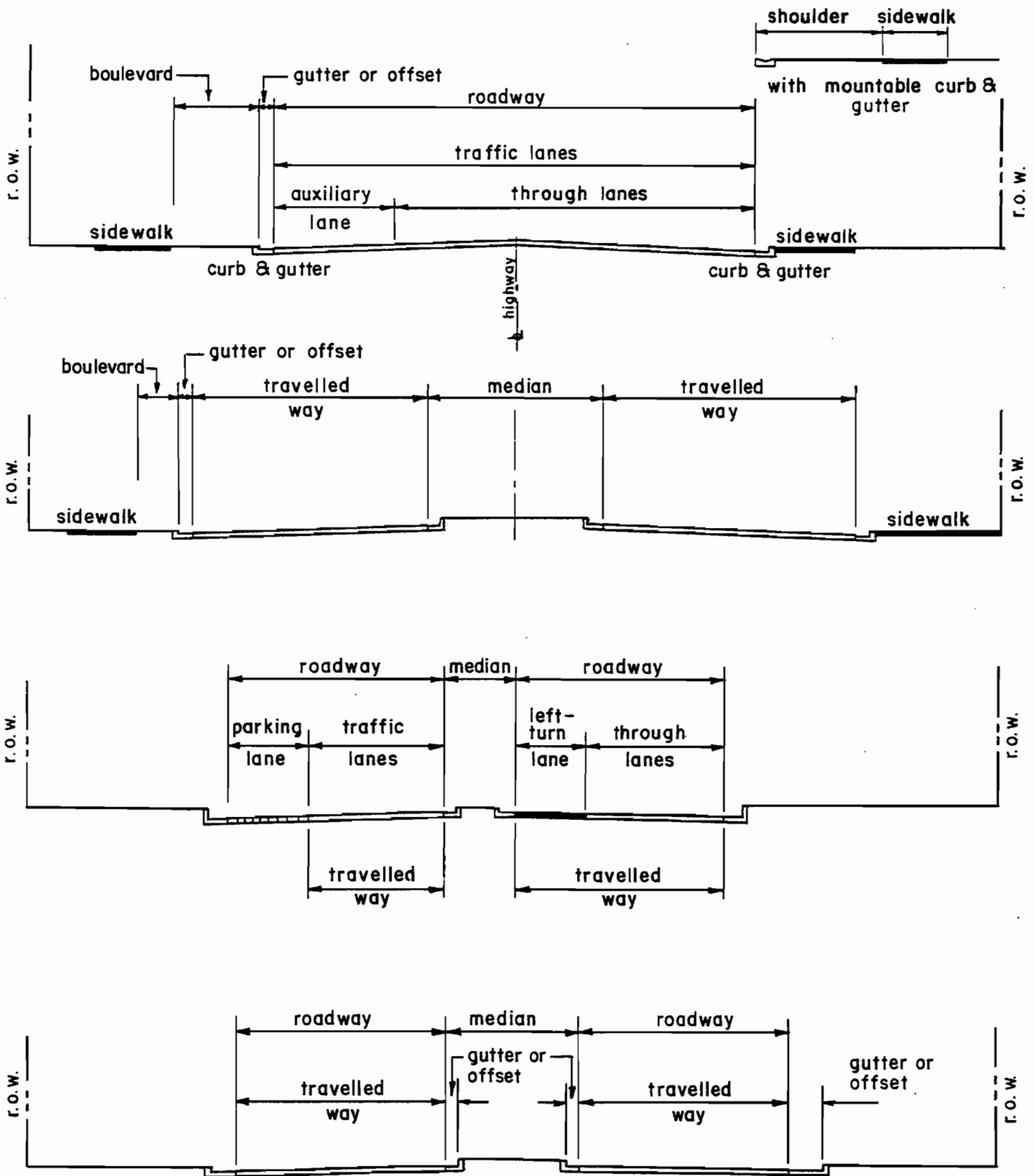

Figure D1-2

Nomenclature for Urban Road Cross Section Elements

D.1.2 STAGE CONSTRUCTION

It is good design practice to consider the need for future expansion of a road facility to provide additional capacity or, perhaps, to convert a road to a different classification. This is particularly important in the design of a cross section and selection of cross section elements and their dimensions.

Recognition should also be given to a change in land use of the area during the foreseeable life of the road, that might affect the classification of a road; for example, a road may be classified as rural initially but may become urban several years later.

In selecting cross section elements it is prudent to approach the design in two ways:

1. Determine the ultimate requirements of the road in terms of classification, design speed, level of service and service volumes, and design a suitable cross section. For the first and any intermediate stages, the cross section consists only of those elements of the cross section that are required to meet immediate needs. Additional elements can then be added in the future as required without wasting capital expenditures made initially.
2. Determine initial requirements and adjust the dimensions so as to allow for future expansion should it be required.

Approach 1 is the better approach, but depends on knowing what the ultimate requirements will be at the outset. This is often not known or may be known in general terms only, in which case the designer should use Approach 2. Often in practice, knowledge of future requirements is limited and the designer may consider both approaches in selecting cross section elements.

To illustrate the above by an example, consider the design of a 4-lane rural freeway. If this road is to be built in an area that is rural and could never conceivably become urban, the appropriate design is a 4-lane rural freeway cross section. Alternatively, if the area is presently rural but is on the fringe of a major metropolitan area, a different planning approach is appropriate. If sufficient right-of-way is being protected for a future urban freeway having six or more lanes, the ultimate design should be that of an urban freeway, providing the appropriate number of lanes for the ultimate requirement. For the first stage all but four lanes are omitted. The first stage design may well be similar to a rural freeway cross section. Cross section considerations for the first and subsequent stages of a

facility are dependent on the expected growth of traffic demands in each time frame.

In some cases it may be economical to provide the earth grading for the ultimate cross section at the first stage of construction.

Most urban freeways will ultimately require six or more lanes and 4-lane urban freeways are rare. Nevertheless, standards for 4-lane urban freeways are shown in this chapter in the event that they will be required.

Widening of 2-lane rural arterial roads to multi-lane undivided or divided highways usually takes place on the outside and culverts are extended at the time of widening. Bridges at underpasses may be built to the ultimate design in the initial stage. Sometimes a 2-lane rural arterial is converted to a 4-lane divided arterial or rural freeway by twinning the existing 2-lane roadway. In this case the dimensions of the future cross section should be determined so that the initial roadway can be properly located within the right-of-way to accommodate future expansion.

Freeways are usually widened in the median so that ramps and bridge structures are unaffected at later stages. This means that the critical dimensions in the cross section in allowing for future expansion are lane width, shoulder width, and median width.

In the case of urban arterial roads, provision for future lanes is usually made in the median. Existing arterial roads for which provision was not made are normally widened on the outsides.

D.1.3 DIMENSIONING

For cross section elements horizontal dimensions are multiples of 0.25 m.

There are some minor exceptions to this practice when using curb with gutter and/or concrete median barriers. Standard gutter widths include 300 mm and 400 mm. The existing concrete median barrier widths are 600 mm and 800 mm; the new 'F' shape standard concrete barrier widths are 630 mm and 820 mm, while the Tall Wall is 800 mm in width. In these cases it is advantageous to select the dimension of an adjacent element so as to make the two added together a multiple of 250 mm. For example, if a curb and gutter having gutter width of 400 mm is used in an urban cross section adjacent to a boulevard, the boulevard dimension could be 1.6 m to make the total width of curb and gutter plus boulevard 2.0 m.

CROSS SECTION ELEMENTS

Horizontal cross section dimensions greater than one metre are stated in metres and decimals of metres. Dimensions less than one metre are stated in millimetres for standard details such as curb and gutter dimensions. Dimensions should be stated to two decimal places unless the second decimal place digit is zero, in which case the second decimal place digit is omitted.

STAGE CONSTRUCTION

Vertical cross section dimensions greater than one metre are stated in metres and those less than one metre are stated in millimetres.

Cross-fall and superelevation are normally stated in terms of vertical rise in metres over a horizontal distance of one metre, for example, 0.02 m/m. However, on Ontario Provincial Standard Drawings (OPSD) and in contract documents, crossfall and superelevation are stated as a percentage, for example, 2%.

D.2 LANE WIDTHS**D.2.1 INTRODUCTION**

Lane width and condition of the road surface have a significant influence on the safety and comfort of the travelling public.

Studies on 2-lane two-way highways have shown that inadequate vehicle lanes less than 3.5 m wide when carrying even moderate volumes of mixed traffic. To provide desirable clearance between trucks, lane widths of 3.75 m may be required. It is generally desirable to maintain this width in higher speed 2-lane roads. Traffic volumes and composition are considerations.

The capacity of a road is markedly affected by lane width. For example, on 2-lane rural roads the capacities of 3.0 m and 3.25 m lanes are reduced to 77% and 83% respectively of the capacity provided by a lane width of 3.75 m. For 4-lane undivided highways these ratios are 88% and 94% respectively. On terms of capacity the effective width is further reduced by lateral obstruction less than 2.0 m from the edge of pavement or narrow shoulders.

D.2.2 THROUGH LANES**POLICY**

STANDARD MINISTRY LANE WIDTHS ARE MULTIPLES OF 0.25 M AND GENERALLY RANGE FROM 3.0 M TO 3.75 M DEPENDING ON A NUMBER OF FACTORS.

Values for lane widths for various classification of roads are set out in the following paragraphs and are also shown together with other cross section elements in A. These are general guidelines to be followed when considering the selection of lane widths. Deviations from desirable design standards may be appropriate as outlined below, particularly for secondary highways. In general, higher design speeds warrant wider lanes. In addition wider lanes are normally appropriate:

- for major highways which typically carry high volumes over long distances between important regional centres;
- where warranted by type, size and volume of commercial traffic.

Narrower lanes are appropriate for minor highways, which are typically local, low volume, short distance roads and provide access to recreational or resource areas.

On new construction and reconstruction projects, lane widths from the tables should be applied.

In rugged terrain narrower lanes may be appropriate by reason of cost and this consideration is reflected in the selection of design speed.

When a highway is to be resurfaced, consideration should be given to retaining the existing cross section dimensions where the dimensions in the tables cannot be accommodated within the existing roadway. Alternatively, standard lane widths may be applied together with reduced shoulder width of 1.0 m gravel or 0.5 m paved is maintained for pavement support. Where the existing pavement is either fully or partially reclaimed and recycled, lane widths are determined as follows:

- reclaimed to full depth and recycled:
 - the new pavement width should be the design standard.
- reclaimed to partial depth and recycled:
 - if the design standard is less than the new existing width, the new pavement width should be identical to the existing width.
 - where partially or fully paved shoulders are required, consider providing the paved portion of the shoulder.
 - if the design standard is greater than the existing width, the design standard should be used. This practice should be applied regardless of shoulder surface treatment.

Where adjacent sections of secondary highways are to be resurfaced and reconstructed, different lane and shoulder widths are acceptable. Transition section may be warranted where changes in width appear to be about.

2-Lane Rural Roads

Lane width for 2-lane King's Highways are shown in Tables D2-1 and D2-2 for a range of traffic volumes stated in terms of Annual Average Daily Traffic (AADT) and Design Hour Volume (DHV). If both are known, DHV should be used for design. Width adjustments for truck percentages are indicated.

The selection of lane width for 2-lane rural roads is dependent primarily in design speed, traffic volume and traffic composition. Service function and topography influence the selection of design speed and therefore have a bearing on lane width.

Lane and shoulder widths may be designated on important long distance highway to ensure continuity, regardless of traffic volumes.

**Table D2-1
LANE WIDTH FOR 2-LANE RURAL KING'S HIGHWAYS**

| Design Speed km/h | Traffic Volume for Design Year | | | | | |
|----------------------|--------------------------------|-----------|-----------|-----------|----------|-------|
| | AADT | | | | | |
| | >4000 | 3000-4000 | 2000-3000 | 1000-2000 | 400-1000 | <400 |
| | DHV | | | | | |
| | >600 | 450-600 | 300-450 | 150-300 | 60-150 | <60 |
| 120 | 3.75 | - | - | - | - | - |
| 110 | 3.75 | 3.75 | 3.75 | 3.5C | - | - |
| 100 | 3.75 | 3.5A | 3.5B | 3.5 | 3.5 | - |
| 90 | 3.5A | 3.5A | 3.5 | 3.25 | 3.25 | - |
| 80 | 3.5 | 3.5 | 3.25 | 3.25 | 3.25 | 3.25D |
| 70 | - | 3.25 | 3.25 | 3.0 | 3.0 | 3.0 |
| 60 | - | - | - | 3.0 | 3.0 | 3.0 |
| 50 | - | - | - | - | - | 2.75 |

Notes:

- Minimum lane width for all paved 2-lane King's Highways is 3.5 m.
- For design use DHV if available.
- Highway 11 in Northern and Northwestern Regions, 3.5 m minimum lane width.
- Highway 17 in Northwestern Regions, 3.75 m minimum lane width.

- A. If truck percentage exceeds 10% increase by one increment.
- B. If truck percentage exceeds 15% increase by one increment.
- C. of truck percentage exceeds 25% increase by one increment.
- D. 3.0 m may be acceptable where the type, size, and volume of trucks ate not significant.

**Table D2-2
LANE WIDTH FOR SECONDARY HIGHWAYS**

| Design Speed km/h | Traffic Volume for Design Year | | |
|----------------------|--------------------------------|----------|-------|
| | AADT | | |
| | >1000 | 400-1000 | <400 |
| | DHV | | |
| | >150 | 60-150 | <60 |
| 100 | 3.5 | - | - |
| 90 | 3.25 | - | - |
| 80 | 3.25 | 3.25* | 3.25* |
| 70 | 3.0 | 3.0 | 3.0 |
| 60 | 3.0 | 3.0 | 3.0 |
| 50 | - | - | 2.75 |

Notes:

- Major secondary highways shall have a minimum lane width of 3.5 mm.
- For design use DHV if available.
- Lane width may be increased by 0.25 m to a maximum of 3.5 m if warranted by type, size and volume of trucks.
- * 3.0 m may be acceptable where the type, size and volume of trucks are not significant.

**Table D2-3
LANE WIDTHS FOR UNDIVIDED & DIVIDED HIGHWAYS**

| | | | | | | | |
|---|--|--------------|------------|-----------|------------|-----------|--|
| <p><u>4-LANE UNDIVIDED AND DIVIDED RURAL ROADS</u></p> <p>Lane widths for 4-lane rural roads depend primarily on design speed and to a small degree on traffic volume or truck percentages. Widths for 4-lane rural roads are:</p> <table border="0"> <tr> <td style="padding-right: 20px;">Design Speed</td> <td>Width</td> </tr> <tr> <td>≥ 100 km/h</td> <td>3.75 m</td> </tr> <tr> <td>< 100 km/h</td> <td>3.50 m</td> </tr> </table> | Design Speed | Width | ≥ 100 km/h | 3.75 m | < 100 km/h | 3.50 m | <p><u>2-LANE AND 4-LANE UNDIVIDED URBAN ROADS</u></p> <p>Lane widths for 2-lane and 4-lane undivided urban roads are shown in Table D2-4 for a range of design speeds from 40 km/h to 80 km/h and for ranges of traffic volumes stated in terms of AADT and DHV. No adjustment for truck percentages is required for the use of this table.</p> |
| Design Speed | Width | | | | | | |
| ≥ 100 km/h | 3.75 m | | | | | | |
| < 100 km/h | 3.50 m | | | | | | |
| <p><u>MULTI-LANE DIVIDED RURAL AND URBAN ROADS</u></p> <p>For multi-lane divided roads the width of the median lane is 3.50 m and all other lanes 3.75 m, to minimize the overall pavement width. The pavement may be striped in equal lane widths.</p> | <p><u>4-LANE DIVIDED URBAN ROADS</u></p> <p>Lane widths for 4-lane divided urban roads depend only on design speed and not on traffic volume or truck percentages. Widths for 4-lane divided roads are:</p> <table border="0"> <tr> <td style="padding-right: 20px;">Design Speed</td> <td>Width</td> </tr> <tr> <td>≥ 80 km/h</td> <td>3.75 m</td> </tr> <tr> <td>< 80 km/h</td> <td>3.50 m</td> </tr> </table> | Design Speed | Width | ≥ 80 km/h | 3.75 m | < 80 km/h | 3.50 m |
| Design Speed | Width | | | | | | |
| ≥ 80 km/h | 3.75 m | | | | | | |
| < 80 km/h | 3.50 m | | | | | | |

**Table D2-4
LANE WIDTH FOR UNDIVIDED URBAN ROADS**

| Design Speed km/h | Traffic Volume for Design Year | | | | |
|----------------------|--------------------------------|-------------|-----------|-----------|-------------|
| | AADT | | | | |
| | >6000 | 3000-6000 | 2000-3000 | 1000-2000 | <1000 |
| | DHV | | | | |
| | >600 | 300-600 | 200-300 | 100-200 | <100 |
| 80 | 3.5 - 3.75* | 3.5 - 3.75* | 3.5 | - | - |
| 60 - 70 | 3.5 | 3.5** | 3.25 | 3.25 | - |
| 50 | - | - | 3.0 | 3.0 | - |
| 40 - 50 | - | - | - | - | 2.75 - 3.0* |
| No. of lanes | 4 | 2 - 4** | 2 | 2 | 2 |

Notes:

Minimum lane width for all paved 2-lane King's Highways is 3.5 m.
For design use DHV if available.

* Upper value is desirable, lower value is acceptable.

** Four lanes are appropriate in the upper part of this traffic range where there is a measurable capacity deficiency with only two lanes.

D.2.3 AUXILIARY LANES

Auxiliary lanes are traffic lanes provided in addition to those which are intended for normal through travel. They are usually relatively short, and each auxiliary lane is introduced for a specific function. Auxiliary lanes may be divided into the following groups:

- right-turn lanes
- left-turn lanes
- continuous left-turn lanes
- acceleration and deceleration lanes
- weaving lanes
- truck-climbing lanes
- passing lanes
- left-turn slip-around lanes

Widths for auxiliary lanes are shown in Table D2-5.

Standard widths for auxiliary lanes are the same for all types of highway and are as follows:

Right-turn lanes - are lanes added to the right of through lanes ahead of intersections to allow right-turning traffic to slow down before making the turn, without interfering with following through traffic, and to provide additional capacity at intersections. The lane may or may not lead directly into an exclusive right-turning roadway.

POLICY

THE WIDTH SHOULD NOT BE LESS THAN 0.25 m LESS THAN THE WIDTH OF THE ADJACENT THROUGH LANE AND IN NO CASE LESS THAN 3.25 m.

Left turn lanes - are lanes added to the left of through traffic lanes to provide a refuge for left-turning traffic waiting to make the turn and to avoid interference with following through traffic. Left-turning traffic typically will move into the left-turning lane, slow down and wait for a suitable gap in oncoming traffic to make the turn. Left-turn lanes are used with and without medians.

POLICY

THE WIDTH OF LEFT-TURN LANES NOT ADJACENT TO A MEDIAN SHOULD NOT BE LESS THAN 0.25 m LESS THAN THE ADJACENT LANE AND IN ANY CASE NOT LESS THAN 3.25 m. LEFT-TURN LANES ADJACENT TO A RAISED MEDIAN WITHOUT A GUTTER SHOULD HAVE THE CURB OFFSET BY 500 mm. LEFT-TURN LANES ADJACENT TO A RAISED OR PAINTED MEDIAN SHOULD BE NOT LESS THAN 3.0 m WIDE.

Continuous left-turn lanes - are introduced between through lanes in both directions to provide storage for left-turning vehicles from either direction and are usually designated for left turns only throughout their length. This form of operation is well suited to 4-lane and multi-lane urban arterial roads where running speeds are relatively low, in the range of 40 km/h to 70 km/h.

POLICY

CONTINUOUS LEFT-TURN LANES SHOULD DESIRABLY BE 4.0 m WIDE. THE ADDITIONAL WIDTH OVER THE ADJACENT THROUGH LANE RECOGNIZES THAT VEHICLES ARE MAKING TURNING MANOEUVRES FROM BOTH DIRECTIONS SIMULTANEOUSLY, AND THE ADDITIONAL WIDTH ADDS A MEASURE OF SAFETY. LESSER WIDTHS TO A MINIMUM OF 3.0 m MAY BE APPLIED WHERE OPERATING SPEEDS ARE LESS THAN 60 km/h.

Acceleration and deceleration lanes - are auxiliary lanes adjacent to through lanes on freeways and arterial roads at interchanges for vehicles changing speed at entrances and exits.

POLICY

THE WIDTH OF THESE AUXILIARY LANES SHOULD BE 0.25 m LESS THAN THE WIDTH OF THE THROUGH LANE, BUT NOT LESS THAN 3.25 m.

Weaving lanes - are auxiliary lanes introduced between an entrance followed by an exit in close succession, usually less than 1000 m, to minimize turbulence in the traffic stream and to maintain adequate capacity.

POLICY

THE WIDTH DESIRABLY SHOULD BE 0.25 m LESS THAN THAT OF THE THROUGH LANE, BUT NOT LESS THAN 3.25 m.

Left-turn slip-around lanes - may be used on 2-lane highways at "T" intersections, where the left-turning traffic volumes do not warrant the standard left-turning treatment, but may pose a threat to the safety of through traffic, and where by-passing vehicles throw gravel from the shoulder onto the highway.

POLICY

THE WIDTH SHOULD BE 0.25 m LESS THAN THE WIDTH OF THE THROUGH LANES BUT NOT LESS THAN 3.25 m.

CROSS SECTION ELEMENTS

LANE WIDTHS

Truck-climbing lanes - are introduced on steep upgrades to provide a lane for trucks and other slow moving vehicles whose speed drops more than 15 km/h because of the grade. The through uphill lanes are kept free for faster traffic. Truck-climbing lanes increase capacity, improve travel times, and reduce accident rates.

Passing lanes - are similar to truck-climbing lanes, but are not necessarily located on upgrades. Passing lanes are applied to 2-lane roads carrying large volumes of slow-moving vehicles (for example, recreational routes). A slow-moving vehicle will cause a queue to form because of lack of passing opportunity, sight distance restrictions or large volumes of opposing traffic. Passing lanes are introduced at intervals to allow following vehicles to overtake.

POLICY

THE WIDTH OF TRUCK-CLIMBING LANES SHOULD BE NOT LESS THAN 0.25 m LESS THAN THE ADJACENT THROUGH LANES, AND IN NO CASE LESS THAN 3.25 m.

POLICY

THE WIDTH OF PASSING LANES SHOULD BE NOT LESS THAN 0.25 m LESS THAN THE ADJACENT THROUGH LANE, AND IN NO CASE LESS THAN 3.25 m.

**Table D2-5
AUXILIARY LANE WIDTHS**

| Auxiliary Lane | Width |
|---|---|
| Right-turn lane | - not less than 0.25 m less than adjacent lane - not less than 3.25 m |
| Left-turn lane not adjacent to a median | - not less than 0.25 m less than adjacent lane - not less than 3.25 m |
| Left-turn lane adjacent to a median | - 3.0 m minimum |
| Continuous left-turn lane | - 4.0 m where design speed is greater than 60 km/h - 3.0 m where design speed is equal to or less than 60 km/h |
| Acceleration and deceleration lanes | - not less than 0.25 m less than adjacent lane - not less than 3.25 m |
| Weaving lane | - not less than 0.25 m less than adjacent lane - not less than 3.25 m |
| Truck-climbing lane | - not less than 0.25 m less than adjacent lane - not less than 3.25 m |
| Passing lane | - not less than 0.25 m less than adjacent lane - not less than 3.25 m |
| Left-turn slip-around lane | - not less than 0.25 m less than adjacent lane - not less than 3.25 m |

D.2.4 RAMPS AND TRANSFER LANES

An interchange is an intersection of two (or more) roadways separated vertically, with at least one roadway for travel between them. These interconnecting roadways are called ramps. A ramp is also applied to separate right turn lanes at channelized at-grade intersections. Transfer lanes are roadways to provide for travel between freeway express lanes and a collector-distributor road or a service road.

POLICY

THE PAVEMENT WIDTH FOR SINGLE-LANE RAMPS AND TRANSFER LANES IS 4.75 m. THE PAVEMENT WIDTH FOR RAMPS AND TRANSFER LANES OF TWO OR MORE LANES SHOULD BE 3.75 m AND ADJUSTED FOR CURVATURE.

The pavement width of 4.75 m is based on the premise that interchanges carry sufficient single unit and semitrailer vehicles to govern design requirements. It also provides for widening on curves of radius greater than 50 m. For 50 m and smaller radii the width should be increased. Refer to Chapter E, Table E8-8 for pavement widths.

D.2.5 PARKING LANES

Cross section design may include provision for parking. This is normally limited to urban roads. Parking facilities should offer safe and convenient access and egress for parking users and at the same time maintain safe and convenient operation for other traffic.

Parking dimensions depend on the vehicle dimensions and steering geometry of vehicles to be parked, and on the form of parking provided. Although there is a marked trend toward smaller cars in recent years which would suggest smaller parking dimensions, parking facilities should be able to accommodate most cars and dimensions should be adequate for all but the larger passenger vehicles.

On-street parking is normally parallel or angled to the alignment of the roadway. Parking at right angles to the alignment offers the most efficient use in terms of parking area, but is seldom considered for on-street parking since it calls for a very wide cross section and is very interruptive to the flow of through traffic.

For parallel parking the parking lane width for design speeds up to 40 km/h should be 2.5 m and for higher design speeds the width should be 3.0 m.

In selecting a suitable stall length for parallel parking, consideration should be given to either individual stalls or to paired parking stalls, as shown in Figure D2-1. The individual stall provides for manoeuvring within its own

length, whereas in the paired stall a manoeuvring area is delineated by paint, and can be used by either of the two vehicles entering or leaving the two adjacent areas.

For individual parking stalls the length should be 7.0 m to 8.0 m to allow for a 6.0 m vehicle. The smaller dimension may be used but may be false economy. Shorter stalls cause drivers to take more time manoeuvring and cause additional delay and turbulence to through traffic.

For paired parking stalls, the stall should be from 5.5 m to 6.0 m and the manoeuvre length from 2.5 m to 3.0 m. Since the manoeuvre area is used for two stalls, the average length of roadway per stall is 6.75 m to 7.5 m, a saving over the individual stall of 3.5% to 6%. Angle parking allows more vehicles to be parked in a given length of roadway than parallel parking; the higher the angle the more vehicles parked. Typical dimensions for angle parking are shown in Figure D2-2.

The choice of angle is usually governed by available width. However, although a higher angle permits more vehicles to be parked in a given length of roadway and reduces wasted area, the higher angle increases manoeuvre time and, consequently, generates more turbulence and delay in the through traffic flow. For in-street angle parking, angles in the 45° to 60° range are normally used.

D.2.6 BUS BAYS

Bus bays have the advantage of separating buses from other traffic during loading and unloading of passengers, however, they sometimes require additional right-of-way.

To be fully effective a bay should include: a deceleration lane or taper to permit convenient entrance to the loading area, a standing space sufficiently long to accommodate the maximum number of buses expected at one time, and a merging lane to provide convenient re-entry into the through traffic lanes. The dimensions of these elements should encourage the bus driver to position the bus completely clear of the through lane of traffic. Ideally the deceleration and acceleration lanes should be sufficiently long so that all acceleration and deceleration is contained within them, however this is normally not feasible.

Taper lengths for deceleration and acceleration should be 25 m each. The loading area should be about 15 m per bus and the width should be 3.0 m to the edge of curb. For details refer to OPSD 501.01.

D.2.7 SUMMARY

Lane widths are summarized in the Appendix to this chapter.

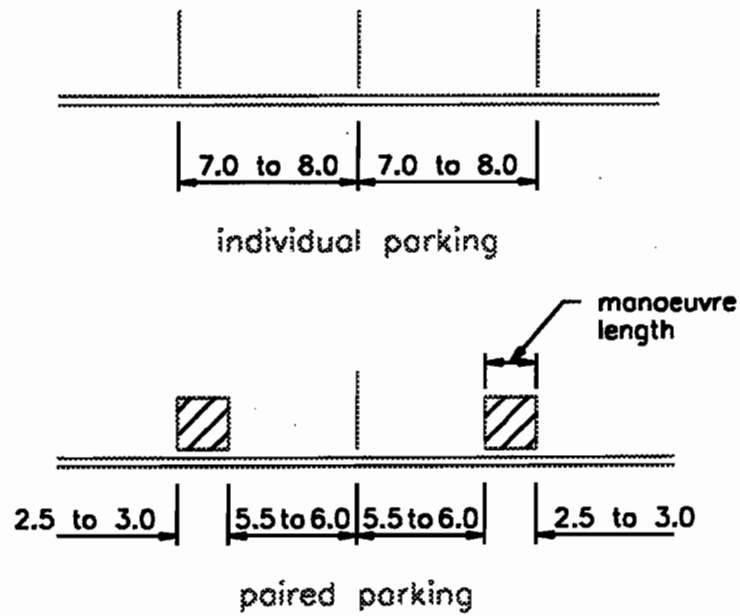

Figure D2-1

Parallel Parking Dimensions

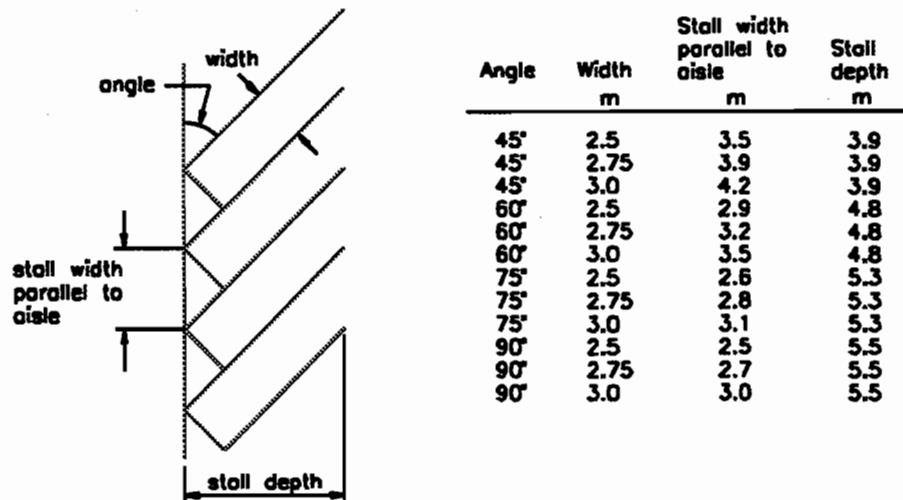

Figure D2-2

Angle Parking Dimensions

D.3 PAVEMENT WIDENING ON CURVES

provided on curves to reduce driver apprehension should a vehicle deviate from the centre of its lane. This amount is dependent on the vehicle speed, as well as curve radius.

D.3.1 BASIS OF DESIGN

Pavement widening on curves is carried out to provide additional load-bearing surface to form part of the traffic lane.

The amount of widening required is the difference between the width required when two trucks meet on the curve and the approach width. The basis of determining the amount of widening is illustrated in Figure D3-1.

Vehicles travelling on a curve occupy a greater width of roadway than they do on tangent sections as a result of the rear wheels tracking inside the front wheel path. The amount of this increase in roadway occupation is dependent on the curve radius and the length and type of vehicle. For the range of radii used on open highways, this additional amount is negligible for passenger cars. However, for trucks it is significant and it is necessary to provide an additional width of pavement to ensure adequate clearance between opposing trucks on curves.

Pavement widening should not be confused with partially paved shoulders which are not intended for normal travel.

D.3.2 DESIGN VALUES

Tables D3-1, D3-2 and D3-3 indicate values of pavement widening for single unit trucks (SU) and semi-trailer combinations (WB-15 and WB-17.5). The range of values for curve widening extends to curve radii corresponding to 30 km/h less than the design speed indicated. This provides widening values for conditions where the overall highway design speed and the operating speed are known to exceed the design speed of an isolated curve.

Maintaining a vehicle centrally located on the lane is more difficult on a curve than on a tangent section. To compensate for this, an additional clearance is

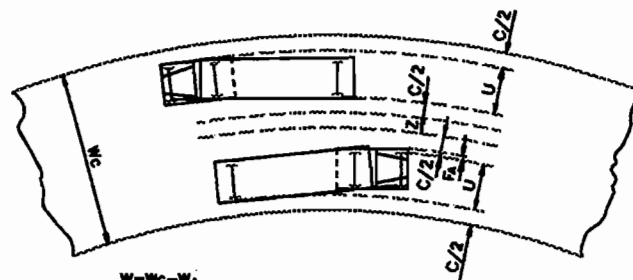

$$W = W_c - W_A$$

where: W = amount of widening
 W_c = pavement width on curve
 W_A = pavement width on tangent

$$W_c = 2(U + C) + F_A + Z$$

where: U = vehicle track width on curve in metres
 C = nominal clearance between vehicles
 0.4572m for 6.0m wide pavements
 0.6096m for 6.5m wide pavements
 0.7620m for 7.0m wide pavements
 0.9144m for 7.5m wide pavements

F_A = front overhang in metres

Z = additional clearance in metres to compensate for difficulty of driving on curves where

$$Z = \frac{0.10456 V}{\sqrt{R}}$$

V = design speed of highway in kilometres per hour
 R = curve radius in metres

Figure D3-1
Basis for Pavement Widening

Table D3-1

PAVEMENT WIDENING VALUES ON CURVES FOR SINGLE UNIT (SU) VEHICLES

| PAVEMENT WIDTH 7.5 m | | | | | | | | |
|----------------------|-----------|-----------|------------|------------|------------|----------|----------|---------|
| Design Speed | | | | | | | | |
| km/h | 50 | 60 | 70 | 80 | 90 | 100 | 110 | 120 |
| W | R | R | R | R | R | R | R | R |
| 1.25 | 50 | 50-55 | 55-65 | | | | | |
| 1.00 | 55-65 | 60-70 | 70-80 | | | | | |
| 0.75 | 70-85 | 75-95 | 85-110 | 90-125 | 130-140 | | | |
| 0.50 | 90-120 | 100-140 | 115-160 | 130-190 | 150-210 | 190-240 | 250-280 | |
| 0.25 | 125-200 | 150-240 | 170-280 | 200-320 | 220-380 | 250-450 | 300-500 | 340-550 |
| PAVEMENT WIDTH 7.0 m | | | | | | | | |
| 1.50 | 50 | 50-55 | 55-60 | | | | | |
| 1.25 | 55-60 | 60-70 | 65-75 | | | | | |
| 1.00 | 65-80 | 75-90 | 80-105 | 90-115 | 130 | | | |
| 0.75 | 85-110 | 95-130 | 110-150 | 120-170 | 140-190 | 190-220 | 250 | |
| 0.50 | 115-170 | 140-200 | 160-240 | 180-280 | 200-320 | 230-380 | 280-420 | |
| 0.25 | 180-350 | 210-450 | 250-500 | 300-650 | 340-750 | 400-900 | 450-1050 | |
| PAVEMENT WIDTH 6.5 m | | | | | | | | |
| 1.75 | | 50 | 55-60 | | | | | |
| 1.50 | 50-55 | 55-65 | 65-75 | | | | | |
| 1.25 | 60-75 | 70-85 | 80-95 | 90-110 | | | | |
| 1.00 | 80-100 | 90-115 | 100-130 | 115-150 | 130-170 | 190-200 | | |
| 0.75 | 105-150 | 120-180 | 140-210 | 160-250 | 180-280 | 210-320 | | |
| 0.50 | 160-280 | 190-350 | 220-420 | 280-500 | 300-600 | 340-700 | | |
| 0.25 | 300-1050 | 380-1300 | 450-1700 | 525-2000 | 650-2500 | 750-2500 | | |
| PAVEMENT WIDTH 6.0 m | | | | | | | | |
| 1.75 | 55 | 55-60 | | | | | | |
| 1.50 | 60-70 | 65-80 | 90 | | | | | |
| 1.25 | 75-95 | 85-110 | 95-125 | 130-140 | | | | |
| 1.00 | 100-140 | 115-160 | 130-190 | 150-220 | 170-250 | | | |
| 0.75 | 150-250 | 170-300 | 200-350 | 230-420 | 280-500 | | | |
| 0.50 | 280-700 | 320-850 | 380-1100 | 450-1300 | 525-1600 | | | |
| 0.25 | 750-10000 | 900-10000 | 1150-10000 | 1400-10000 | 1700-10000 | | | |

Notes:

- W - widening values in metres are based on SU design vehicles travelling at the design speed.
- R - denotes centreline radius in metres.
- For methods of widening see Standards OPSD 213.01 and OPSD 213.02.
- Not to be used for interchanges.

Table D3-2

PAVEMENT WIDENING VALUES ON CURVES FOR TRACTOR-SEMI-TRAILER (WB-15) VEHICLES

| PAVEMENT WIDTH 7.5 m | | | | | | | | |
|----------------------|----------|----------|----------|----------|----------|-----------|----------|---------|
| Design Speed | | | | | | | | |
| km/h | 50 | 60 | 70 | 80 | 90 | 100 | 110 | 120 |
| W | R | R | R | R | R | R | R | R |
| 2.00 | 65-70 | 75 | 75-80 | | | | | |
| 1.75 | 75-80 | 80-85 | 85-90 | 90-95 | | | | |
| 1.50 | 85-90 | 90-95 | 95-105 | 100-110 | | | | |
| 1.25 | 95-105 | 100-115 | 110-125 | 115-130 | 130-140 | | | |
| 1.00 | 110-130 | 120-140 | 130-150 | 140-170 | 150-180 | 190-200 | | |
| 0.75 | 140-170 | 150-180 | 160-200 | 180-220 | 190-240 | 210-250 | 250-280 | |
| 0.50 | 180-230 | 190-250 | 210-280 | 230-300 | 250-340 | 280-380 | 300-400 | 340-450 |
| 0.25 | 240-350 | 280-400 | 300-450 | 320-525 | 350-575 | 400-650 | 420-700 | 475-800 |
| PAVEMENT WIDTH 7.0 m | | | | | | | | |
| 2.00 | 75 | 75-80 | 75-85 | | | | | |
| 1.75 | 80-85 | 85-95 | 90-100 | 90-105 | | | | |
| 1.50 | 90-105 | 100-110 | 105-120 | 110-130 | 130-140 | | | |
| 1.25 | 110-125 | 115-130 | 125-140 | 140-160 | 150-170 | | | |
| 1.00 | 130-160 | 140-170 | 150-190 | 170-210 | 180-230 | 190-240 | 250 | |
| 0.75 | 170-210 | 180-240 | 200-250 | 220-280 | 240-300 | 250-340 | 280-380 | |
| 0.50 | 220-320 | 250-350 | 280-400 | 300-450 | 320-500 | 350-550 | 400-600 | |
| 0.25 | 340-600 | 380-700 | 420-800 | 475-950 | 525-1050 | 575-1200 | 650-1300 | |
| PAVEMENT WIDTH 6.5 m | | | | | | | | |
| 2.00 | 80-85 | 85-90 | 90-95 | 90-105 | | | | |
| 1.75 | 90-100 | 95-105 | 100-115 | 110-125 | 130 | | | |
| 1.50 | 105-120 | 110-130 | 120-140 | 130-150 | 140-160 | | | |
| 1.25 | 125-150 | 140-160 | 150-180 | 160-190 | 170-210 | 190-230 | | |
| 1.00 | 160-200 | 170-220 | 190-240 | 200-250 | 220-280 | 240-320 | | |
| 0.75 | 210-280 | 230-320 | 250-350 | 280-400 | 300-450 | 340-450 | | |
| 0.50 | 300-500 | 340-575 | 380-650 | 420-750 | 475-850 | 475-950 | | |
| 0.25 | 525-1600 | 800-1800 | 700-2200 | 800-2500 | 900-3000 | 1000-3500 | | |

Notes:

- W - widening values in metres are based on WB-15 design vehicles travelling at the design speed.
- R - denotes centreline radius in metres.
- For methods of widening see Standards OPSD 213.01 and OPSD 213.02.
- Not to be used for interchanges.

Table D3-3

PAVEMENT WIDENING VALUES ON CURVES FOR TRACTOR-SEMI-TRAILER (WB-17.5) VEHICLES

| PAVEMENT WIDTH 7.5 m | | | | | | | | |
|----------------------|------------|------------|------------|------------|------------|------------|------------|------------|
| Design Speed | | | | | | | | |
| km/h | 50 | 60 | 70 | 80 | 90 | 100 | 110 | 120 |
| W | R | R | R | R | R | R | R | R |
| 2.00 | 115-125 | 120-130 | 125-140 | 130-150 | 140-150 | 150-160 | 160-170 | 160-180 |
| 1.75 | 130-150 | 140-160 | 150-170 | 160-180 | 170-190 | 170-200 | 180-210 | 190-230 |
| 1.50 | 160-180 | 170-190 | 180-210 | 190-220 | 200-240 | 210-250 | 220-250 | 240-280 |
| 1.25 | 190-240 | 200-250 | 220-250 | 230-300 | 250-320 | 280-340 | 280-300 | 300-380 |
| 1.00 | 250-320 | 280-350 | 280-380 | 320-420 | 340-450 | 350-500 | 380-550 | 400-575 |
| 0.75 | 340-525 | 380-600 | 400-650 | 450-700 | 475-800 | 525-850 | 575-950 | 600-1050 |
| 0.50 | 550-1250 | 150-1400 | 700-1600 | 750-1800 | 850-2000 | 900-2200 | 1000-2500 | 1100-3000 |
| 0.25 | 1300-10000 | 1500-10000 | 1700-10000 | 2000-10000 | 2200-10000 | 2500-10000 | 3000-10000 | 3500-10000 |
| PAVEMENT WIDTH 7.0 m | | | | | | | | |
| 2.00 | 105-120 | 115-125 | 120-130 | 125-140 | 130-140 | 140-150 | 150-160 | |
| 1.75 | 125-140 | 130-140 | 140-150 | 150-160 | 150-170 | 160-180 | 170-200 | |
| 1.50 | 150-170 | 160-180 | 160-190 | 170-200 | 180-220 | 190-230 | 210-240 | |
| 1.25 | 180-210 | 190-230 | 200-240 | 210-250 | 230-280 | 240-300 | 250-320 | |
| 1.00 | 220-280 | 240-300 | 250-340 | 280-350 | 300-380 | 320-420 | 340-450 | |
| 0.75 | 300-420 | 320-475 | 350-525 | 380-575 | 400-600 | 450-650 | 475-750 | |
| 0.50 | 450-800 | 500-900 | 550-1050 | 600-1150 | 650-1300 | 700-1400 | 800-1600 | |
| 0.25 | 850-3500 | 950-4500 | 1100-5000 | 1200-6000 | 1400-7000 | 1500-8000 | 1700-10000 | |
| PAVEMENT WIDTH 6.5 m | | | | | | | | |
| 2.00 | 100-110 | 105-115 | 110-125 | 120-130 | 125-140 | 130-140 | | |
| 1.75 | 115-130 | 120-130 | 130-140 | 140-150 | 150-160 | 150-170 | | |
| 1.50 | 140-150 | 140-160 | 150-170 | 160-180 | 170-200 | 180-210 | | |
| 1.25 | 160-190 | 170-200 | 180-220 | 140-230 | 210-250 | 220-250 | | |
| 1.00 | 200-250 | 210-250 | 230-280 | 240-320 | 280-340 | 280-350 | | |
| 0.75 | 280-350 | 280-380 | 300-420 | 340-450 | 350-500 | 380-550 | | |
| 0.50 | 380-600 | 400-650 | 450-750 | 475-800 | 525-900 | 575-1000 | | |
| 0.25 | 650-1600 | 700-1800 | 800-2200 | 850-2500 | 950-2500 | 1050-3000 | | |

Notes:

- W - widening values in metres are based on WB-17.5 design vehicles travelling at the design speed.
- R - denotes centreline radius in metres.
- For methods of widening see Standards OPSD 213.01 and OPSD 213.02.
- Not to be used for interchanges.

D.3.3 WARRANTS

The necessity of widening the pavement on a curve is dependent upon one truck meeting another on a curve, the frequency of which is dependent on truck volumes and distribution, curve radius and design speed. Failure to provide widening on a curve will result in a higher degree of concentration required by the driver and possible reduction in speed.

On a curvilinear section of road in which the majority of the alignment is on curve, the probability that two trucks will meet on a curve is greater than the case where most of the alignment is on tangent. However, the probability that two trucks will meet on any particular curve is independent of the configuration of the alignment on either side of the curve. The need for pavement widening on a curve is not dependent on the frequency of curves.

D.3.3.1 Undivided Roadways**POLICY**

FOR 2-LANE ROADWAYS WHERE THE NUMBER OF TRUCKS IN BOTH DIRECTION IS LESS THAN 15 PER HOUR, PAVEMENT WIDENING IS NOT REQUIRED. WHERE THE NUMBER OF TRUCKS IS 15 PER HOUR OR MORE PAVEMENT WIDENING SHOULD BE APPLIED AS FOLLOWS:

- **WHERE SU TRUCK VOLUME IS 15 PER HOUR OR MORE, USE TABLE D3-1**
- **WHERE WB-15 TRUCK VOLUME IS 15 PER HOUR OR MORE, USE TABLE D3-2**
- **WHERE WB-17.5 TRUCK VOLUME IS 15 PER HOUR OR MORE, USE TABLE D3-3**

Theoretically widening of a 4-lane undivided roadway should consist of the additional clearance required for the physical occupation of the roadway. Since the additional clearance is required to compensate for opposing vehicles only, this component need not be included twice for a 4-lane highway where some of the vehicles are travelling in the same direction. The possibility of trucks occupying all lanes at a given location on a curve is so remote that the absence of the small amount of widening required to compensate for the physical roadway occupation of the extra vehicles is not significant.

Pavement widening values given in Tables D3-1, D3-2 and D,3-3 should therefore be applied to all undivided roadways regardless of the number of lanes. These values should not be applied to divided highways or interchange ramps. For widths of pavement of interchange ramps refer to Chapter E, Table E8-8.

D.3.3.2 Divided highways

On divided highways vehicles only encounter other vehicles moving in the same direction. The relative speeds are such that the additional clearance (Z) is not required. Furthermore, due to the relatively flat curves utilized on highways of this type, the effects of vehicular off-tracking are usually sufficiently small to be insignificant. Pavement widening on divided highways therefore is not required.

D.3.3.3 Ramps

Ramp pavement widths for channelized intersections and interchange ramps are based on vehicle off-tracking and clearance requirements similar to the pavement widening considerations for open highways. However, due to the relatively small radius curves associated with this type of design the width requirements are considerably larger. Pavement widths of 4.75 m on single lane ramps do not require widening to accommodate off-tracking, providing the radius is greater than 50 m.

Design considerations include provision for passenger cars, single unit and tractor semi-trailer design vehicles, together with operating conditions which assume one-way traffic with provision for passing stalled vehicles and two-way traffic.

Design values for ramps and transfer lanes pavement widths are indicated in Section D2.4 and values for widening are given in Chapter E, Table E8-8.

D.3.4 APPLICATION

The pavement widening values given in Tables D3-1, D3-2 and D3-3 represent the total amount of widening required.

For new construction and reconstruction projects, curve widening should be applied by adding half of the total requirement to each side of the highway. Equal division of the widening is not practical however, with values ending in 0.25 or 0.75. A preferred treatment is to round the total widening value to a higher even digit before dividing in half. The normal shoulder width should be maintained over the length of curve widening.

Curve widening on resurfacing projects should be carried out with a corresponding reduction in shoulder width to maintain the existing subgrade. A minimum shoulder width of 1.0 m gravel, or 0.5 m paved, must be maintained to provide the pavement with adequate lateral support.

An exception to the minimum shoulder width requirement may be considered in the application of resurfacing and curve widening to secondary highways,

particularly those with low traffic volumes. Where the required curve widening closely approaches or exceeds the existing shoulder width, an acceptable and cost-effective design alternative to road widening is to utilize the entire shoulder width to achieve the curve widening.

For resurfacing projects with no recycling, or with partial-depth recycling, widening values of 0.25m may be ignored. If the widening requirement is 0.5m or less, the total widening may be applied to the inside of curve to avoid application of a narrow strip of base pavement to both sides of the highway prior to resurfacing.

For resurfacing projects with full-depth recycling, curve widening should be applied by adding one half of the total requirement to each side. Widening values ending in 0.25 or 0.75 should be rounded to a higher even digit before dividing in half.

Since the amount of pavement widening is a function of the curve radius, the widening should be applied over the length of the spiral curve in such a fashion that a smooth edge of pavement is produced. For

unspiralled curves the widening should be applied over the corresponding spiral length had the spiral been applied. The method of attaining the pavement widening is illustrated in Ontario Provincial Standards Drawings OPSD 213.01 and OPSD 213.02.

Pavement widening may be warranted on several successive horizontal curves so that a significant length of highway has a continuous variation in pavement width. In such a situation of a wider pavement over the total section of highway should be considered. The amount of widening should be representative of the required widening on individual curves and not necessarily the widening required by the smallest radius curve. Alternatively, less widening could be applied over the total section with additional widening on the smaller radius curves.

Each situation should be assessed independently considering how closely the warrants are met, the length of the highway section under consideration, the frequency of curves and the amount of widening required for each curve. A uniform pavement width is desirable but may not always be economically practical.

D.4 PAVEMENT CROSSFALL AND SUPERELEVATION**D.4.1 CROSS-FALL REQUIREMENTS****POLICY**

ON 2-LANE HIGHWAYS THE PAVEMENT IS NORMALLY CROWNED AT THE CENTRELINE AND THE PAVEMENT SLOPES DOWN TO EITHER EDGE AT A CROSS-FALL RATE OF 2%.

ON 4-LANE UNDIVIDED HIGHWAYS AND 4-LANE DIVIDED HIGHWAYS WITH A FLUSH MEDIAN, THE CROWN IS NORMALLY PLACED IN THE CENTRE OF THE PAVEMENT OF MEDIAN, AND CROSS-FALL TO EITHER PAVEMENT EDGE IS 2%.

ON A 4-LANE DIVIDED HIGHWAY WITH A DEPRESSED MEDIAN, THE CROWN IS NORMALLY PLACED AT THE CENTRE OF EACH ROADWAY WITH A CROSS-FALL OF 2% TO EACH EDGE. FOR ROADWAYS ON STRUCTURES, THE CROSS-FALL SHOULD BE A MINIMUM OF 2%.

There are two reasons for this: the first is to permit storm-water to drain to either side of the roadway; the second is to facilitate the treatment of the roadway with de-icing chemicals which are spread in a narrow strip about the crown line, allowing the action of traffic and cross-fall to further spread the chemicals across the entire pavement. If the road eventually requires expansion to six lanes by adding two lanes in the median, the additional lanes will slope toward the median.

If a 4-lane divided highway is to be expanded to six lanes within a short period of time of initial construction, it should be designed for six lanes and built without the median lanes initially, in this case both lanes of each roadway will slope towards the outer edge.

For 6-lane divided highways, the crown for each roadway is applied to the common edge of the centre and median lanes, the two outside lanes having a cross-fall of 2% towards the outside edge, and the median lane having a cross-fall of 2% draining towards the median. If this cross section is expanded to an 8-lane cross section with the additional lanes in the median, the additional lanes have 2% cross-fall applied draining towards the median.

The above cross-fall requirements are illustrated in Figure D4-1.

Cross-fall on auxiliary lanes is the same as that of the adjacent through lane.

At intersections where two roads on tangent intersect, normal cross-fall is maintained on the major road, and cross-fall on the minor road is run out on the approaches to the intersection to match the profile of the major road. This treatment is typical of intersections controlled by a stop sign on the minor road. In the case of an intersection where the two roads are of equal importance, or where the intersection is signalized, the normal cross-fall is run out on all four approaches so that the cross-fall on each road matches the profile of the crossing road. Simply put, the pavements are warped to maintain smooth profiles for traffic on both roads. This topic is dealt with in more detail in Chapter E, Section E.4.

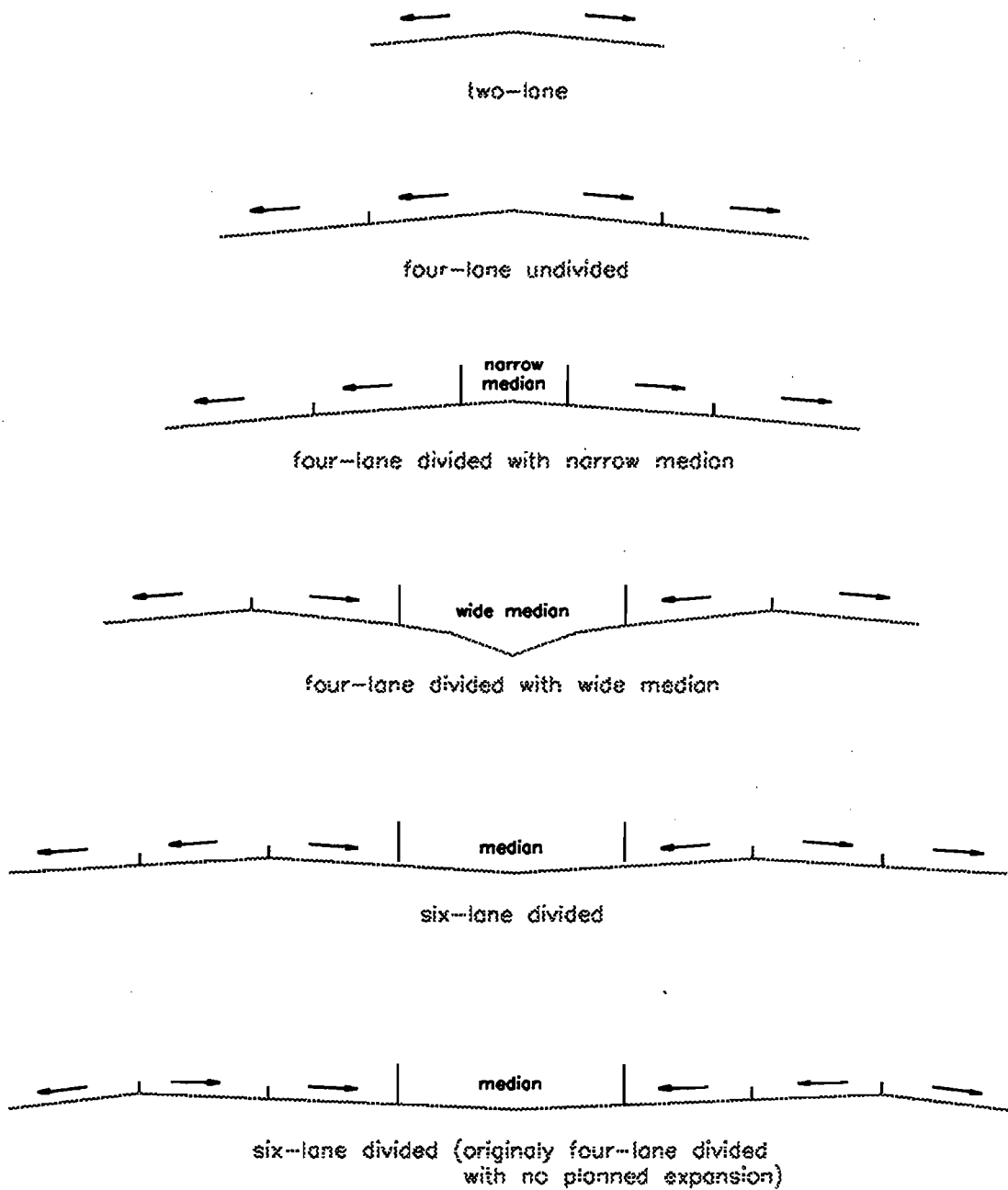

Figure D4-1
Application of 2% Cross-Fall on Tangent Section

D.4.2 SUPERELEVATION REQUIREMENTS

Superelevation is the practice of tilting the pavement on circular curves, such that the pavement drains towards the centre of the curve. The objective is to assist the driver in safely manoeuvring the vehicle through the curve without an undue reduction in speed.

As a vehicle travels along the circular curve it experiences radial acceleration towards the centre of the curve produced by centripetal forces acting on the vehicle. If no superelevation were applied the centripetal force would be supplied solely by friction between pavement and tires. If superelevation is applied, a component of the force of gravity acting on the vehicle will contribute towards the centripetal force reducing reliance on friction and providing a safer condition. The total friction and superelevation requirement to negotiate a curve is a function of speed and radius. This relationship is explained in detail in Chapter C, Alignment, Section C.3.2.2.

POLICY

MAXIMUM SUPERELEVATION RATE FOR DESIGN IS:

- **FOR URBAN FREEWAY INTERCHANGE RAMPS WHERE A HIGH LEVEL OF MAINTENANCE PREVAILS AND LITTLE ICE OR SNOW ACCUMULATION IS ANTICIPATED: 8%.**
- **FOR ALL OTHER ROADWAYS: 6%.**

A more detailed explanation of these values is discussed in Chapter C, Alignment, Section C.3.2.3. Distribution of superelevation for curves of radius

greater than minimum is discussed in Chapter C, Alignment, Section C.3.2.6. Design values for superelevation are given in Chapter C, Alignment, Tables C3-3 and C3-4. The transition from normal cross-fall on a tangent to full superelevation on a circular curve is normally applied over a length referred to as the transition length. Its purpose is to provide a natural manoeuvre between a tangent and circular curve to avoid a rapid change in cross-fall, or a jerk, and to maintain the natural position of the vehicle on the lane. The transition length is normally applied over a spiral on the horizontal alignment. Design values for spiral lengths are explained in Chapter C, Section C.3.3.5 and the basis of spiral design is discussed in Section C.3.3.4. Methods of attaining superelevation between tangent and circular curve are discussed in Chapter C, Alignment, Section C.3.3.6 and are shown in Figure C3-6.

The removal of normal cross-fall before and after superelevated cross section is referred to as tangent runoff. This is explained in Chapter C, Alignment, and is illustrated in Figures C3-2 and C3-6. Tangent runoff is usually a maximum of 1:400.

Where the horizontal alignment does not include a spiral transition curve between tangent and circular curve, transition between normal cross-fall and super-elevation should be applied partly on the tangent and partly on the circular curve. The method of attaining this superelevation transition is described in Chapter C, Alignment, Section C.3.2.7.

On bridge structures the roadway surface standards should match those for the approach roadway.

D.4.3 APPLICATION OF SUPERELEVATION

D.4.3.1 Rate of Change

The basis for acceptable rates of change of superelevation are comfort, safety and convenience of operation. Changes in the rate of superelevation occur on mainline design at the beginning and end of circular curves and other areas where changes in direction of vehicle travel occur; for example, on turning roadways at intersections and at interchanges on ramps and ramp terminals.

Acceptable rates of change are a function of design speed and radius of curve.

(i) Two-lane Roadways

Relative slope is the slope or profile of the outer edge of the pavement in relation to the profile of the centreline. It is dependent on the rate of superelevation being developed, the length over which it is developed, and the width of the pavement. It is therefore an expression of rate of change of superelevation. The maximum permissible relative slope varies with design speed and acceptable values are shown in Table D4-1.

(ii) Turning Roadways

The term turning roadways refers to separate roadways to provide for right-turning traffic at intersections and curvilinear sections of interchange ramps.

The rate of change of cross-fall on intersection curves, ramp curves and ramp terminals varies with the design speed. As the design speed is increased the length over which the change in superelevation can be made is reduced.

Design values for rates of change of cross-fall are shown on Table D4-2. These values are suitable for single-lane ramps. For 2-lane ramps lower values should be used. Theoretically the maximum rate of change for 2-lane roadways should be 50% of that for single lane roadways, however, this may generate transition lengths which cannot be achieved at an acceptable cost and values of 75% are acceptable.

D.4.3.2 Difference in Pavement Cross-Fall

The phenomenon of adjacent traffic lanes having different rates of cross-fall or superelevation gives rise to a ridge at the common edge, referred to as algebraic difference or roll-over.

Where the design of the superelevation meets speed/radius requirements and the minimum design values for rate of change of cross-fall, but exceeds the maximum algebraic differences in pavement cross slope, the alignment design should be re-examined.

Figure D4-2 illustrates the development of superelevation at a turning roadway exit terminal for alternative alignments and auxiliary lane treatments.

Too great a difference in cross-fall may cause vehicles travelling between lanes to sway, giving rise to some discomfort, and possible hazard. Significant differences in cross-fall can occur in the vicinity of ramp exit terminals and ramp entrance terminals. The maximum algebraic difference in the cross-fall between adjacent lanes is given in Table D4-3.

D.4.3.3 Undivided Roadways

On 2-lane highways and 4-lane undivided highways superelevation is normally applied between a tangent section and a fully superelevated curve by revolving the pavement about either the centreline or one of the edges of the roadway. These methods are described in Chapter C, Alignment, Section C.3.3.6 and are illustrated in Figure C3-6.

Table D4-1

MAXIMUM RELATIVE SLOPE BETWEEN OUTER EDGE OF PAVEMENT AND CENTRELINE FOR 2-LANE ROADWAY

| Design Speed, km/h | | | | | | | | |
|--------------------|------|------|------|------|------|------|------|------|
| 40 | 50 | 60 | 70 | 80 | 90 | 100 | 110 | 120 |
| Relative Slope, % | | | | | | | | |
| 0.70 | 0.65 | 0.60 | 0.55 | 0.51 | 0.47 | 0.44 | 0.41 | 0.38 |

The minimum length (L) is given by the equation:

$$L = \frac{100 we}{2s}$$

where w is the width of pavement in metres

e is the superelevation being developed in metres per metre

s is the relative slope, percentage

Table D4-2

DESIGN VALUES FOR RATE OF CHANGE OF CROSS-FALL FOR SINGLE-LANE TURNING ROADWAYS

| Design Speed km/h | | | |
|--|------|------|-------------|
| 25 and 30 | 40 | 50 | 55 and more |
| Rate of Change of Superelevation, %/m length | | | |
| 0.25 | 0.23 | 0.20 | 0.16 |

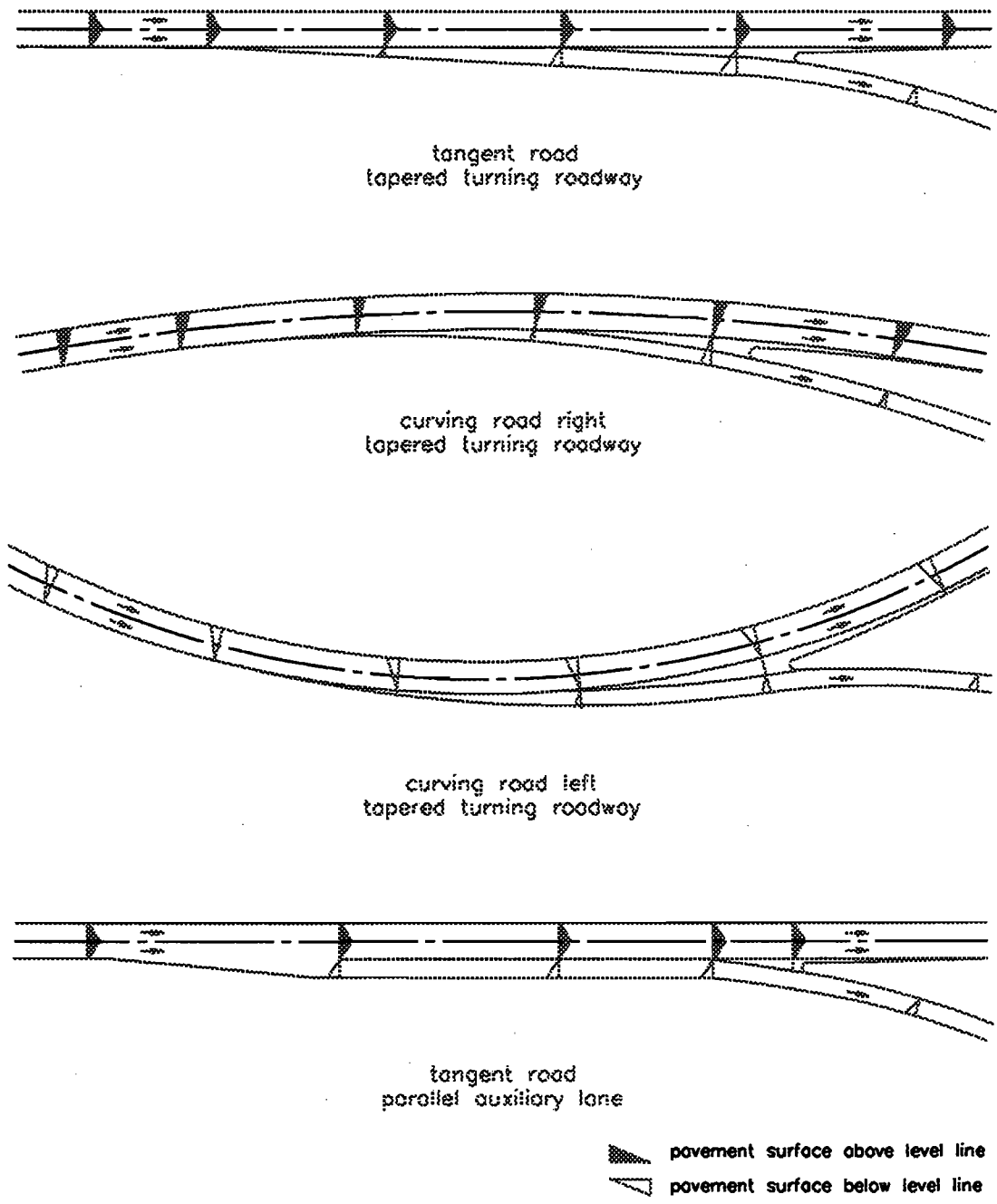
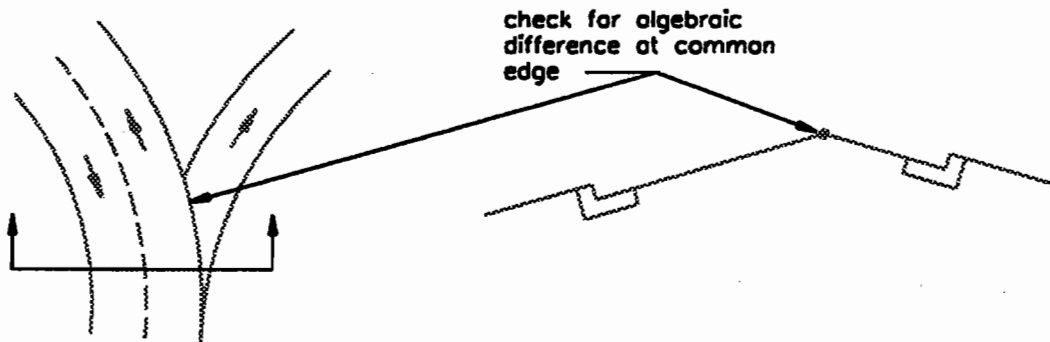

Figure D4-2
Development of Superelevation at Turning Roadway Exit Terminals

TABLE D4-3

**MAXIMUM ALGEBRAIC DIFFERENCE IN PAVEMENT
CROSS-FALL AT TURNING ROADWAY EXIT TERMINALS**



| Design speed of exit or entrance curve km/h | Maximum algebraic difference in cross-fall m/m |
|---|--|
| up to 30 | 0.06 |
| 30 to 50 | 0.05 |
| 50 & over | 0.04 |

D.4.3.4 Divided Roadways

On divided roadways with wide medians, the median pavement edges are usually maintained at the same elevation as shown in Figure D4-3 and, each pavement is revolved about the median edge as illustrated in Chapter C, Alignment, Figure C3-6.

On divided roadways with narrow medians consisting of a median barrier and paved shoulders, the median barrier edges at the two shoulders desirably should be at the same elevation, as shown in Figure D4-3.

On divided roadways where additional lanes are being added to the median and provision for the above treatment was not made in the original design, median shoulder edges will not be at the same elevation. This difference in elevation can be taken up with an asymmetric concrete median barrier, as shown in Figure D4-3.

The use of curb and gutter with any guide rail system is not recommended. Refer to section D.6, Medians and Outer Separations for the recommended procedure.

D.4.3.5 Cross-Fall and Superelevation for Resurfacing Projects

POLICY

ON RESURFACING AND/OR RE-ALIGNMENT PROJECTS, CROSS-FALL AND SUPERELEVATION SHOULD BE RESTORED TO DESIGN STANDARDS.

On resurfacing projects restoration to acceptable standards should only be made if it can be justified. These justifications must be clearly stated in the Design Criteria and documented in detail in the project file.

The following justification guidelines are suggested, but should be used with care and judgement on the part of the designer:

(i) Cross-fall

During the preliminary design stage, the costs to restore a section of pavement to both acceptable tolerances and design cross-fall standards must be determined and carefully assessed.

Resurfacing of a pavement is normally undertaken to strengthen the pavement structure and restore ride and/or skid resistance. This resurfacing can be carried

out by a conventional overlay on the existing surface with some padding, by partial depth removal, or by an in-place recycling process including hot/cold in-place recycling. In conjunction with resurfacing to improve ride and pavement structure, cross-fall and superelevation correction may be incorporated to improve rideability and safety.

Minimum acceptable standards are provided in Table D4-4.

Where a conventional resurfacing or in-place recycling project is undertaken, the conventional or recycled binder course must be thick enough to allow for cross-fall correction to an acceptable tolerance. Where partial depth removal of the pavement is undertaken, milling can be utilized to correct cross-fall or superelevation to an acceptable tolerance. The average cross-fall rate selected for a specific resurfacing project must be reasonably consistent throughout and within the acceptable tolerances outlined above.

Restoration to acceptable standards should be justified in terms of the service to high speed traffic, potential reduction in accident experience and anticipated life expectancy of the project.

For example, resurfacing is occasionally programmed as a short-term improvement with the intention of carrying out more extensive work, such as road widening, in 5-10 years.

Restoration to acceptable standards may also be justified where new procedures with limited correction capabilities are being used.

(ii) Superelevation

In many cases design speed and posted speed are the same, particularly for low volume roads. To determine the need for superelevation correction, the following data should be obtained for each horizontal curve:

- existing superelevation
- accident experience
- 85th percentile average running speed
- maximum safe speed as determined by Table C3-5 of Chapter C.

CROSS SECTION ELEMENTS

PAVEMENT CROSS-FALL AND SUPERELEVATION

The existing superelevation on curves may remain less than that shown in Tables C3-3 and C3-4 of Chapter C, provided the following conditions are met:

- There is no unusual accident experience, such as loss of control type, that can be related to inadequate superelevation.
- The maximum speed given by Table C3-5 of Chapter C based on the prevailing rate of superelevation and the maximum friction factor is at least 10 km/h higher than the 85th percentile operating speed. (Generally the 85th percentile operating speed will be close to the posted speed limit, but can be significantly higher.)

Where the above conditions are not met, corrections should be applied to make the superelevation as shown in Tables C3-3 and C3-4 of Chapter C as follows:

- design standard, based on design speed, or
- acceptable standard, based on posted speed, or the 85th percentile operating speed plus 10 km/h, whichever is greater.

The cost of correction based on design and acceptable standards must be determined and taken into account in selecting the course of action to be followed.

Table D4-4

PAVEMENT CROSS-FALL FOR RESURFACING PROJECTS

| Design Speed km/h | Cross-Fall | | Maximum Algebraic Difference (driving lanes) % |
|--------------------------|-----------------------------|------------------------------|--|
| | Design Standard % | Acceptable Range % | |
| 120 | 2 | 1.5 - 2.5 | 5 |
| 100 | 2 | 1.5 - 3.0 | 6 |
| 80 | 2 | 1.5 - 3.5 | 7 |

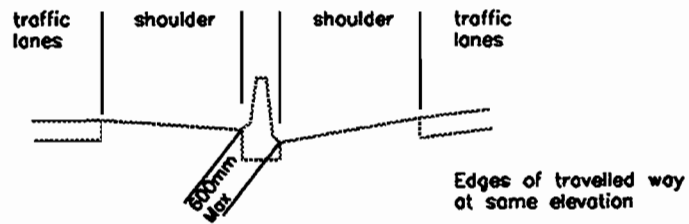
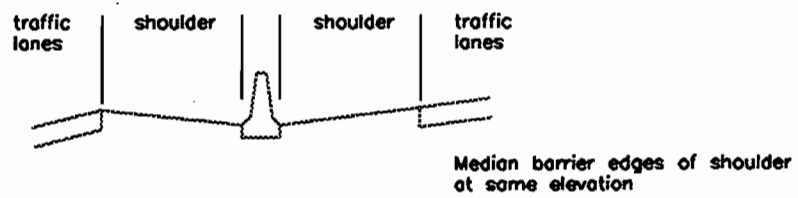
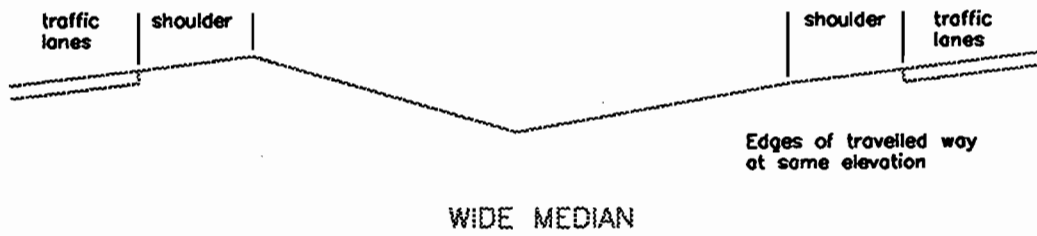

NARROW MEDIAN

Figure D4-3
Application of Superelevation on Divided Roadways

D.5 SHOULDERS**D.5.1 FUNCTION**

A shoulder is the part of the roadway adjacent to traffic lanes provided as refuge for stopped or disabled vehicles, for travel by emergency vehicles and for lateral support for the roadway structure.

Shoulders are normally provided on rural highways, and all freeways.

On highways in urban areas, shoulders are usually omitted, except on freeways, since speeds are lower and it is less hazardous for a stalled vehicle to be on the travelled way. Also, property cost in urban areas is usually too high to justify the provision of shoulders.

Shoulders provide an area that may be used to avoid a potential accident or to minimize the severity of an accident. Shoulders improve highway capacity and provide a storage area for snow removal. Shoulders may also be used for bus bays to allow buses stopping, to load and unload while remaining clear of traffic in the adjacent lane.

Most 2-lane highways have paved traffic lanes and gravel shoulders, in which case the driver recognizes the shoulder for what it is and is not encouraged to treat it as a traffic lane. Where shoulders are paved for reasons such as traffic volume, reduction in shoulder-related accidents, maintenance or drainage, the shoulder can be delineated by means of a contrasting colour and/or texture.

It is important for the operation of the road to make a clear distinction between traffic lanes and shoulders so that the use of a shoulder as a traffic lane is not encouraged. This can be accomplished in a number of ways. The shoulder may be treated with a coarser surface than that of the traffic lane, so that if a vehicle inadvertently leaves the lane and travels onto the shoulder, the change in tone of tire noise will alert the driver.

Pavement edge striping is an important device for delineating the shoulders, particularly where the shoulder is partially paved with the same mix as the through travel lane. Shoulders usually have a steeper cross-fall than the adjacent travel lane and this further assists the driver in distinguishing between the two.

D.5.2 TREATMENT OF SURFACE

Shoulders are gravel surfaced, unless partial paving or full paving is warranted.

D.5.2.1 Partially Paved Shoulders**POLICY**

PARTIALLY PAVED SHOULDERS SHOULD BE INCLUDED ON ALL KING'S HIGHWAYS UNLESS OTHERWISE RECOMMENDED BY THE REGIONAL MANAGER OF ENGINEERING AND RIGHT-OF-WAY.

Partially paved shoulders are not normally used on secondary highways, however, at the discretion of the Regional Manager of Engineering and Right-of-Way, and based on engineering evaluation, they may be provided. Appropriate documentation of the shoulder treatment and rationale should be included in the Design Criteria. Where a shoulder is partially paved, a width of 0.5 m closest to the adjacent travel lane is hard surfaced, usually with asphalt, and the remaining shoulder surface is gravel.

On existing highways having a median shoulder width and/or outside shoulder width ≤ 1.0 m, the full shoulder width should be paved to avoid the existence of a narrow gravel strip which is extremely difficult to maintain.

Partially paved shoulders should preferably be constructed in conjunction with resurfacing, reconstruction or new construction. In order to avoid a joint at the interface, partially paved shoulders are not normally placed adjacent to the existing pavement without resurfacing. A stand-alone partially paved shoulder retrofit may be justified, at the discretion of the District/Region, based on continuity, median safety or maintenance considerations.

Partially paved shoulders should be carried through on passing lanes and truck-climbing lanes.

The beginning and termination points of 0.5 m wide partially paved shoulder sections should be tapered to the through pavement edge over a distance of 10 m. Exceptions to this are at speed-change lanes where the partially paved shoulder should be feathered into the auxiliary lane taper, or where the presence of curves would create discontinuity of the edge of paved surface.

As a general rule, continuous partially paved shoulders should terminate either at an intersection where there is a significant change in traffic volume or at locations where changes in the characteristics of roadside developments occur, such as the beginning of an urban cross section.

D.5.2.2 Fully Paved Shoulders**POLICY****FULL SHOULDER PAVING IS WARRANTED:**

- **ON ALL FREEWAYS HAVING THREE OR MORE LANES IN ONE DIRECTION;**
- **ON 4-LANE DIVIDED HIGHWAYS FOR THE MEDIAN SHOULDER;**
- **IN URBAN AREAS:**

WHERE THE SIDEWALK IS LOCATED 3 m OR LESS FROM THE THROUGH LANES, AND WHERE REVERSE SHOULDERS ARE UTILIZED TO SUIT EXISTING CONDITION;

WHERE THREE OR MORE ADJACENT COMMERCIAL ESTABLISHMENTS ARE PRESENT, OR

WHERE THE TOTAL DENSITY OF ENTRANCES (ALL TYPES) EXCEEDS 10 PER 300 m PER SIDE.

ON 2-LANE HIGHWAY SECTIONS, SHOULDER PAVING SHALL BE APPLIED ON BOTH SIDES OF THE HIGHWAY

ON HIGHWAYS WITH MORE THAN TWO LANES, SHOULDER PAVING SHALL APPLY ONLY TO THE SIDE ON WHICH THE ENTRANCES ARE LOCATED;

- **AS PROTECTION AGAINST SHOULDER EROSION ON GRADIENTS. THE CONDITIONS UNDER WHICH PROTECTIVE MEASURES ARE WARRANTED ARE:**

GRADIENTS LESS THAN 3%; NO TREATMENT IS REQUIRED,

GRADIENTS OF 3% TO 5%; TREATMENT SHOULD BE BASED ON LOCAL CONSIDERATIONS,

GRADIENTS GREATER THAN 5%; TREATMENT ADVISABLE.

To prevent excessive shoulder erosion caused by storm-water, steep grades and superelevation, shoulder paving is an acceptable alternative to the application of curb and gutter. The entire width of shoulder should be paved.

D.5.3 WIDTH**POLICY**

FOR HIGH-SPEED HIGHWAYS THE NORMAL SHOULDER WIDTH IS 3.0 m.

FOR HIGHWAYS OF LOWER SPEED AND/OR LOWER VOLUME, THIS WIDTH OF SHOULDER IS NORMALLY NOT JUSTIFIED AND A NARROWER SHOULDER MAY BE APPLIED.

THE MINIMUM SHOULDER WIDTH ACCEPTABLE FOR PAVEMENT SUPPORT IS 0.5 m IF THE SHOULDER IS PAVED, AND

1.0 m IF THE SHOULDER IS GRAVEL SURFACED.

IT IS DESIRABLE THAT A VEHICLE STOPPED ON A SHOULDER FOR EMERGENCY REASONS BE CLEAR OF THE PAVEMENT BY AT LEAST 0.25 m AND PREFERABLY 0.5 m.

The minimum usable shoulder width required to accommodate a disabled vehicle is 2.0 m.

Where curb and gutter is placed at the outside edge of a shoulder, the gutter width is regarded as part of the usable shoulder width. Where a mountable curb and gutter is placed between the traffic lane and the shoulder, the entire unit is treated as part of the usable shoulder.

Where guide rails, walls or other obstructive elements are introduced adjacent to a shoulder, it is desirable that the shoulder be wide enough to allow for opening of a vehicle door. However, it is not always practical or economical to do so.

Shoulders desirably should be continuous so that at any location along the roadway a driver can leave the traffic lanes to use the shoulder. If the shoulder is intermittent some drivers may find it necessary to stop in the traffic lane, precipitating a hazardous condition. However, it may not always be economical to maintain shoulder width in all cases as for example in deep rock cuts.

Shoulder widths are normally multiples of 0.5 m. Shoulder widths for undivided rural highways are given in Table D5-1. Shoulder widths on bridge decks for various conditions are given in Section D.7.3.2.

For 4-lane divided highways the width of the shoulders are as follows:

- right shoulder is the same as for undivided highways, see Table D5-1.
- left or median shoulder is 1.0 m.

For multi-lane divided highways the width of the shoulders are as follows:

- right shoulder is 3.0 m.
- left or median shoulder is 2.5 m.
Where a median barrier system is placed, the median shoulder width varies according to the type of barrier used, see section D.6.

For all interchange ramps the right shoulder width is 2.5 m.

The right shoulder on a single-lane ramp may be gravel, partially paved, or paved depending on rural or urban locations and maintenance considerations.

The right shoulder of a ramp with two or more lanes is normally paved.

For interchange ramps the left shoulder width is as follows:

- single-lane ramp - 1.0 m
- 2-lane ramp - 1.0 m
- ramps of more than two lanes - 2.5 m

The left shoulder is normally paved.

The shoulder width for collector-distributor roads on urban freeways should be the same as those for express lanes.

The shoulder widths adjacent to acceleration, deceleration and weaving lanes on freeways are the same as those of the adjacent ramps.

For speed-change lanes at entrances and intersections on roads other than freeways, the shoulder width is 1.0 m. The transition in shoulder width should take place over the length of taper of the speed-change lane.

For truck-climbing and passing lanes the shoulder width should be the same as the shoulder width on the typical cross section for the roadway, but may be reduced to not less than 1.0 m where the cost of maintaining the shoulder width is considered prohibitive, in which case the shoulder should be fully paved.

D.5.4 CROSS-FALL AND SUPERELEVATION

Standard values for cross-fall and superelevation of shoulders on undivided and divided highways are listed and illustrated in Figures D5-1, D5-2, and D5-3:

- on tangent, unpaved, partially paved or paved -0.06 m/m
- on the high side of superelevated sections, unpaved, partially paved or paved as noted in Table D5-2
- on paved part of partially paved shoulder on high side of superelevated section same as adjacent superelevation
- on the low side of superelevated sections, unpaved, partially paved or paved - 0.06 m/m

Table D5-1

**SHOULDER WIDTH FOR UNDIVIDED KING'S HIGHWAYS
AND SECONDARY HIGHWAYS**

| Design Speed km/h | Traffic Volume for Design Year | | | | | |
|----------------------|--------------------------------|------------------|------------------|------------------|----------|------------------|
| | AADT | | | | | |
| | >4000 | 3000-4000 | 2000-3000 | 1000-2000 | 400-1000 | <400 |
| | DHV | | | | | |
| | >600 | 450-600 | 300-450 | 150-300 | 60-150 | <60 |
| 120 | 3.0 | - | - | - | - | - |
| 110 | 2.5 ¹ | 2.5 ¹ | 2.5 | 2.5 | - | - |
| 100 | 2.5 ¹ | 2.5 | 2.5 | 2.0 ³ | 1.0 | - |
| 90 | 2.5 | 2.5 | 2.0 ² | 2.0 | 1.0 | - |
| 80 | 2.5 | 2.5 | 2.0 | 2.0 | 1.0 | 1.0 ⁴ |
| 70 | - | 2.0 | 2.0 | 1.0 | 1.0 | 1.0 ⁴ |
| 60 | - | - | - | 1.0 | 1.0 | 1.0 ⁴ |
| 50 | - | - | - | - | - | 1.0 ⁴ |

Notes:

1. If truck percentage exceeds 10% increase by 0.5 m.
2. If truck percentage exceeds 15% increase by 0.5 m.
3. If truck percentage exceeds 25% increase by 0.5 m.
4. Shoulder width of 0.5 m is acceptable on King's Highways where there is no foreseeable possibility of the road being paved within a 20-year period. Where guide rail is installed, shoulder width must be 1.0 m.

Minimum width for pavement support: 0.5 m paved, 1.0 m gravel surfaced.

Minimum usable width for disabled vehicle: 2.0 m.

Highway 11 in Northern and Northwestern Regions, 2.0 m minimum shoulder width.

Highway 17 in Northern and Northwestern Regions, 2.5 m minimum shoulder width.

Table D5-2

**SUPERELEVATION FOR SHOULDERS ON
HIGH SIDE OF SUPERELEVATED SECTIONS**
(For Urban Ramp Design, See Figure D5-4)

| | | | | | | | | | |
|------------------------------|-------|-------|-------|-------|-------|-------|-------|-------|-------|
| Adjacent Traffic Lane | +0.06 | +0.05 | +0.04 | +0.03 | +0.02 | +0.01 | 0.00 | -0.01 | -0.02 |
| Shoulder | -0.02 | -0.02 | -0.02 | -0.03 | -0.03 | -0.03 | -0.04 | -0.05 | -0.06 |

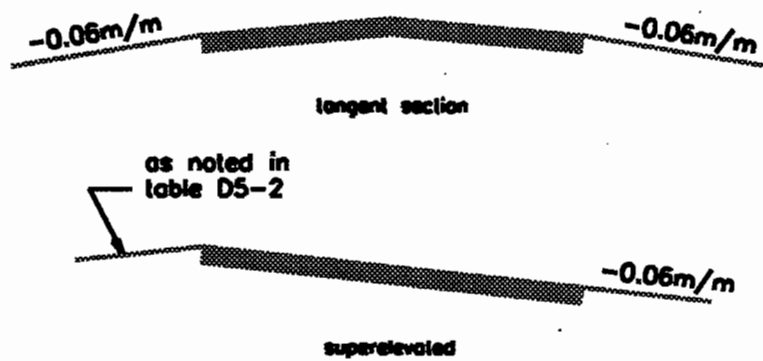

Figure D5-1
Unpaved Shoulder Cross-Fall

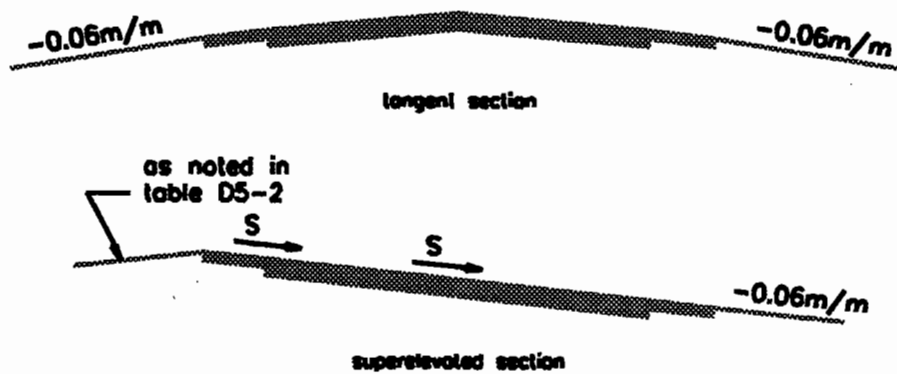

Figure D5-2
Partially Paved Shoulder Cross-Fall

CROSS-SECTION ELEMENTS

SHOULDERS

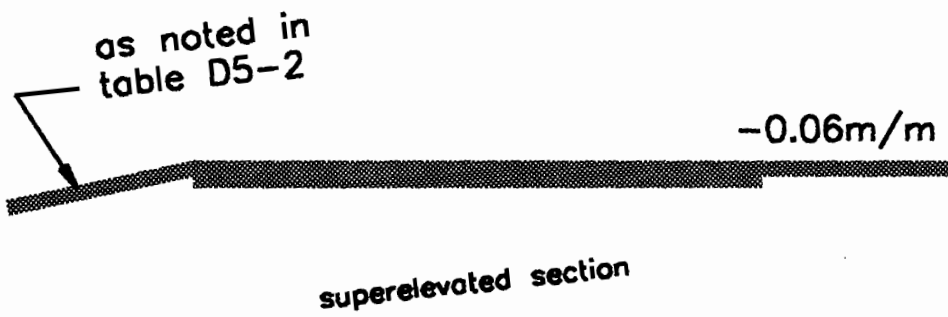

Figure D5-3
Paved Shoulder Cross-Fall

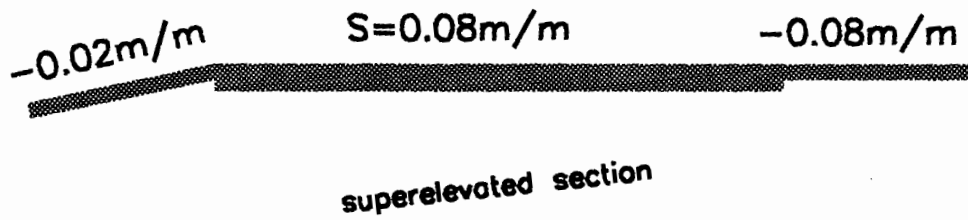

Figure D5-4
Paved Shoulder Cross-Fall
Superelevated Section - Urban Ramp

D.5.5 SHOULDER ROUNDING

Shoulder rounding is a transition between the shoulder cross-fall and the granular side slope. It provides additional material beyond the shoulder for lateral support of the shoulder and provides a smooth transition for control of an errant vehicle leaving the roadway. Therefore, at higher speeds, the transition should be extended over a greater distance.

To provide additional stability for steel beam guiderail, roundings of 1.0 m minimum with 0.5 m from edge of shoulder to rounding breakpoint should be used.

In some conditions the granular material within the rounding transition and on the granular side slope may require a granular sealant treatment to control erosion.

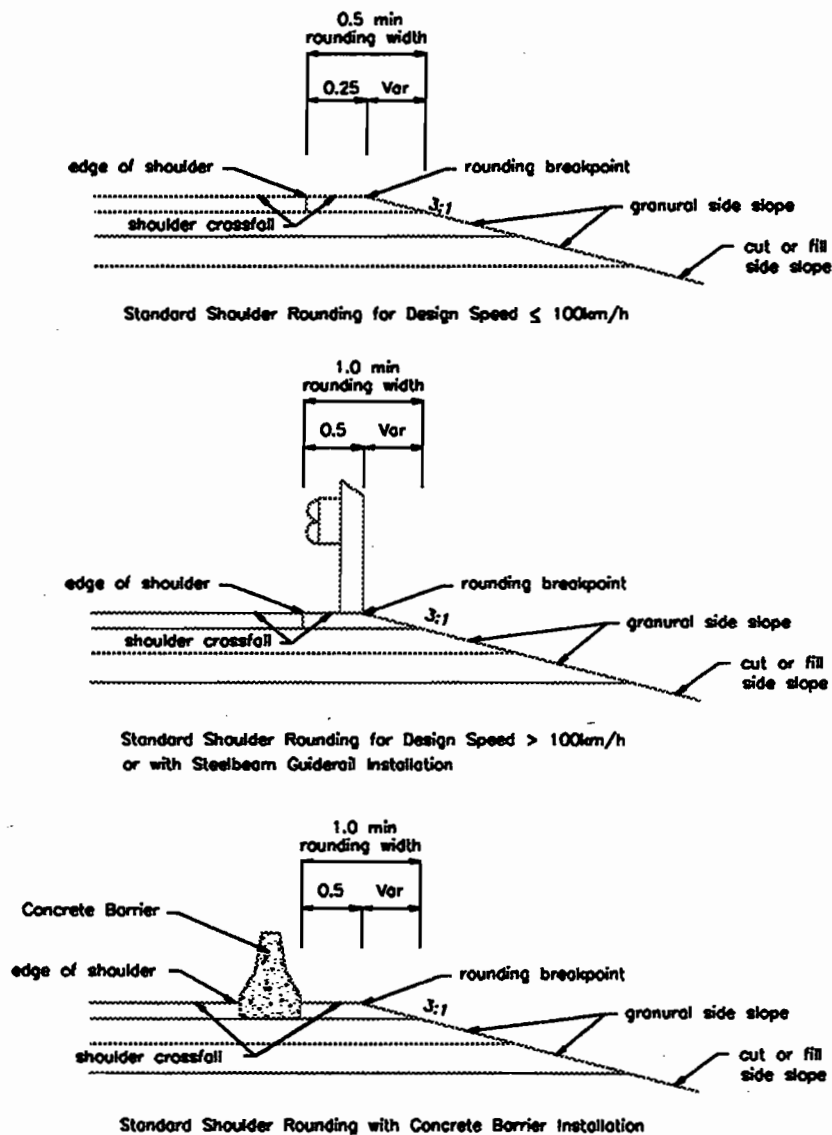

Figure D5-5

Shoulder Rounding

D.5.6 GUIDELINES FOR SHOULDER DESIGN ON RESURFACING PROJECTS

On resurfacing projects, the shoulder cross-fall or superelevation should be improved to the design standard regardless of the treatment of cross-fall and superelevation to the adjacent traffic lanes.

For resurfacing shoulders without adjacent curbs the fill slope or cut side slope should be maintained. The increased depth of shoulder will necessitate a reduction in shoulder width as shown in Figure D5-6.

The resultant reduced shoulder width is acceptable provided both the following guidelines are met:

- the reduction in width is not more than 0.5 m
- the usable shoulder width is not less than 1.0 m

Where these guidelines are not met the shoulder should be widened to provide either:

- an acceptable shoulder width equal to the width occurring on most of the project, or
- the standard width noted in Section D.5.3.

The cost of widening to either of the above criteria should be compared.

If the shoulder requires widening over more than 10% of the project length excluding intersection improvement, application of the standard width should be considered.

Resurfacing of full or partially paved shoulders should be dealt with on a project-specific basis. The cross-fall or superelevation desirably should be as shown in Section D.5.4.

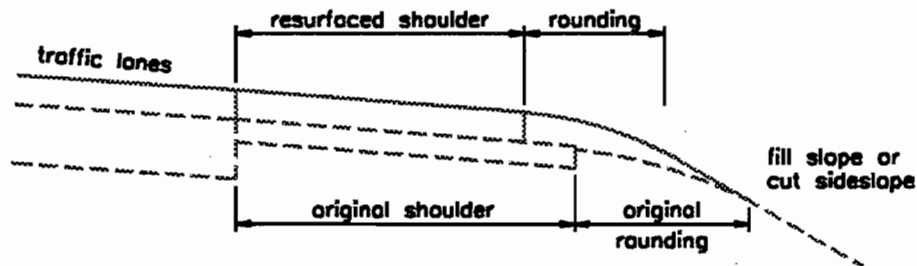

Figure D5-6

Shoulder Treatment on Resurfacing Projects

D.6 MEDIANS**D.6.1 GENERAL**

Where opposing traffic lanes are separated laterally, that part of the cross section between opposing traffic lanes is referred to as the median. A median where uni-directional traffic lanes are separated, is referred to as an outer separation. The median and outer separation generally includes shoulders. The width of the median and outer separation is the distance between the edges of the through traffic lanes.

A median functions as a safety device which provides some measure of freedom from interference of opposing traffic. Medians of sufficient width also provide a recovery area for out-of-control vehicles, storage area for emergencies, speed-change lanes for left-turn and U-turn traffic, and reduction in headlight glare.

Medians should be visible day and night and should be in definite contrast to adjacent traffic lanes. Medians may be flush, raised or depressed in relation to, adjacent traffic lanes.

Medians should be as wide as possible, however, economic conditions may preclude such designs. In any case, the median width should be in balance with the other elements of the cross section and the character of the area.

Median widths may be as narrow as 1 m and as wide as 30 m. Widths above 30 m are usually associated with independent alignments, in which case the roadways are designed separately, and the area between is left in its natural state. A median width between 10 m and 15 m with 10:1 slopes does not usually require a traffic barrier and is considered to be the optimum median concept.

A median separating traffic moving in the same direction, known as an outer separation, forms a physical barrier between adjacent traffic lanes. There is little advantage in wider outer separations. They need only be wide enough to provide for elements such as shoulders, curbs, barriers, bridge piers and lighting poles.

Warrants for median barriers are based on traffic volumes and median widths. They are presented in the "Median Barrier Warrant Guide" of the "Roadside Safety Manual". Refer also to the manual for barrier selection, curb design, etc.

On urban freeways when the capacity of a facility is reached and the freedom to manoeuvre within the traffic stream has become difficult the median shoulder may be replaced with a traffic lane. However, this option is not recommended and each location should be assessed for adverse consequences, such as pavement deterioration, inability of access for police or emergency vehicles and finding a refuge area for disabled vehicles.

D.6.2 FREEWAYS

Median and outer separation characteristics for freeways depend primarily on the basic number of freeway lanes, and whether the freeway is designed with a rural or urban type cross section.

Freeways in an urban environment would normally have:

10 year projected AADT greater than 75,000, 6 lanes or more, multiple interchanges spaced 1 to 2 km apart, freeway to freeway interchanges, urban drainage, complex signing requirements including FTMS, illumination, and a significant requirement for protection other than for medians.

D.6.2.1 Rural Freeways

Rural freeways are usually designed with a depressed median of sufficient width to allow the roadbed to drain into the median and to obviate the need for any form of median barrier. See Figure D6-1.

Median side slopes should not be steeper than 4:1. Flatter slopes are beneficial to safety in that a driver leaving the traffic lanes and travelling in the median is more likely to be able to regain control without incurring vehicle damage or occupant injury. Flatter slopes should be used where feasible in terms of cost and property.

When warranted, an appropriate longitudinal median barrier system shall be selected. The types of traffic barriers used are the concrete or IBC barrier, steel beam, box beam* or six cable guide rail. The median treatment may be sod, stabilized granular or pavement depending on the traffic barrier to be used.

It should be noted that when a barrier is used the median must have side slopes of 10:1 or flatter, or, a barrier may be installed on a 6:1 slope providing the barrier system is located at least 4.5 m from the rounding break point.

* Box beam may be used provided posted speed is less than 80 km/h.

A median width of 22.0 m allows for practical side slopes of 6:1 and normally allows the roadbed to drain without subdrains. It will also permit the addition of future lanes leaving a standard urban multi-lane median width of 7.5 m. See Figure D6-2.

D.6.2.2 Staged Freeway Construction

In urban fringe areas it may be appropriate to build a rural freeway with a depressed median, recognizing that the character of the area will become urban and that the future lanes will be required together with a flush or raised median. In this case the ultimate cross section should be designed and then components removed to give the depressed median width at the initial stage. For example, an ultimate 8-lane cross section may have a 7.5 m median consisting of a 630 mm concrete median barrier and two 3.435 m shoulders. The initial stage could be built as a 4-lane cross section with a 22.0 m depressed median which allows for the future lanes, shoulders and standard or high performance median barrier. The staging for this case is shown in Figure D6-2.

Wider medians may be employed to:

- provide independent roadway alignments in rugged terrain,
- improve aesthetics.

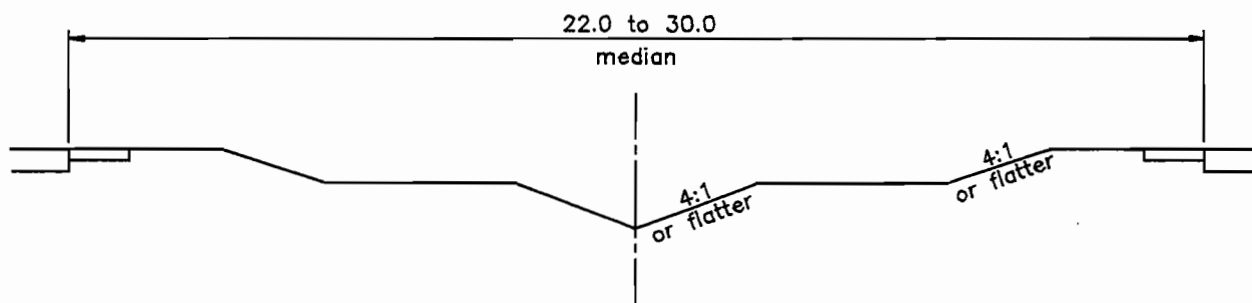

**Figure D6-1
Median Width for Rural Freeways**

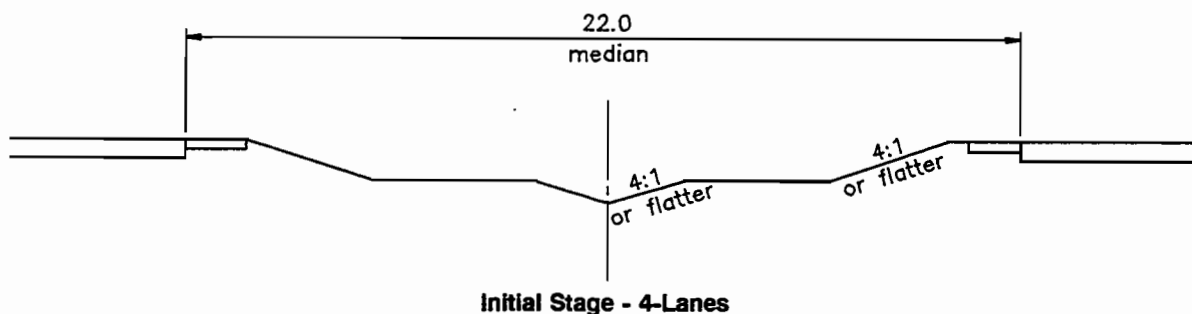

Initial Stage - 4-Lanes

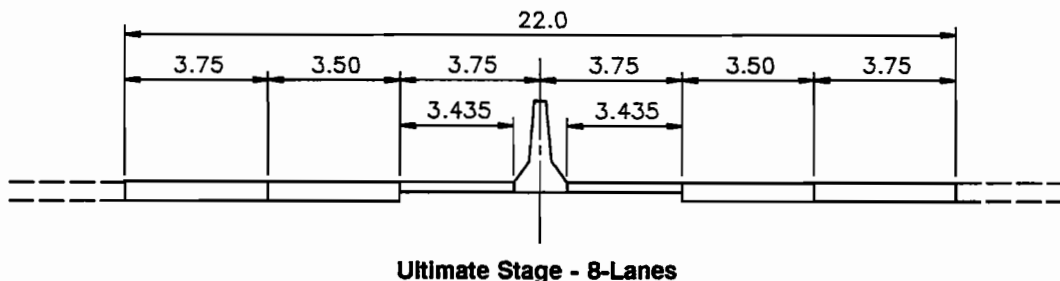

Ultimate Stage - 8-Lanes

**Figure D6-2
Stage Construction for Freeway Medians**

D.6.2.3 Urban Freeways

Medians for urban freeways are either flush or raised with some form of median barrier. Median width is dependent on shoulder width, barrier type, and whether or not there is provision for structure piers.

The standard median width of 6.0 m for a 4-lane urban freeway and 7.5 m for an urban multi-lane freeway should be maintained.

For a 10-lane or more urban freeway the standard median width may be increased to 8.5 m where multiple bridge pier intrusions would not provide for a minimum 3.0 m shoulder width. In isolated locations a smooth lane shift may be appropriate.

For 6 - 8 lane urban freeways the 3.0 m minimum shoulder width is also desirable but may, in isolated locations, such as bridge piers, be reduced to a minimum of 1.5 m.

(i) Flush Median

The 6.0 m median width will accommodate various median traffic barrier systems; however, a minimum shoulder width of 2.5 m should be maintained.

A wider left-hand shoulder width of 3.0 m is required on multi-lane freeways to provide additional safety. When the wider left-hand shoulder is provided on a multi-lane cross-section with three or more lanes in one direction, emergency stops may be facilitated for vehicles travelling in the lane adjacent to the median. In addition the driver's door can be opened without the vehicle encroaching into the adjacent lane.

A concrete barrier is commonly used on multi-lane urban freeways with a flush median. The shoulders are sloped to drain toward the barrier where catch basins are installed to collect the runoff. An IBC Mark VII may be considered as an optional design to a standard concrete median barrier where a minimum 3.0 m clearance is provided between the edge of the travelled lane and the barrier face. See Figure D6-3(a).

Where a Freeway Traffic Management System (FTMS) overhead sign structure, or high mast lighting is to be placed in a newly constructed multi-lane urban freeway median, high performance median barrier special design concrete footings are required. The shoulder thus produced will vary according to the type of barrier used.

Desirably a 3.0 m shoulder width should be maintained throughout. However, on projects where high mast lighting or FTMS overhead sign footings are to be located the minimum shoulder width may be reduced to 2.9 m; consequently the shoulder width varies and becomes narrower at each obstacle.

High Performance Barrier

Where a high performance median barrier is required either the Ontario 'Tall Wall' concrete barrier or an IBC Mark VII HV barrier system shall be placed. In a standard 7.5 m median both Ontario 'Tall Wall' concrete barrier and IBC Mark VII HV allow for an effective shoulder width in excess of 3 m. See Figure D6-3(b).

When applying the Ontario 'Tall Wall' or Mark VII HV barrier system a minimum clear shoulder width of 3.0 m should be provided, therefore, the required minimum median width must be 6.8 m for the Ontario 'Tall Wall' barrier and 7.12 m for the IBC Mark VII HV barrier system. For the application of high performance barriers refer to the Traffic Barrier Manual. The above also applies to staged freeways.

An alternative design utilizing a twin concrete barrier system may be used to provide additional protection for a high mast light standard. The minimum median width required for this installation must be 9.0 m, thus producing a minimum shoulder width of 3.0 m on both sides of the concrete barriers. The twin concrete barrier design may be continuous or tapered at a rate of 40:1, into a single concrete median barrier. See Figure D6-3(c). Half sections next to bridge piers may also be utilized in confined conditions.

Box beam barrier may also be used with the flush median, but its use is restricted; installations are limited to highways where the posted speed is less than 80 km/h; see the Traffic Barrier Manual.

When applying box beam barrier in a flush median, the shoulder should be sloped and a drainage channel created 0.5 m from centreline. The drainage channel may be placed on either side of the centreline. See Figure D6-3(d).

Double steel beam barrier may be used in flush medians where truck volumes are less than 9,000 per day. The shoulder slopes should intersect 0.5 m from the face of the barrier to create a drainage channel. See Figure D6-4 (a).

The steel beam barrier system at bridge piers can also be placed in a flush median with provision of adequate slopes for drainage. See Figure D6-4(b).

On existing facilities, where provision is required in the median for a bridge pier, a reduced shoulder width on the approaches to the pier may be acceptable, in which case the standard median width can be maintained.

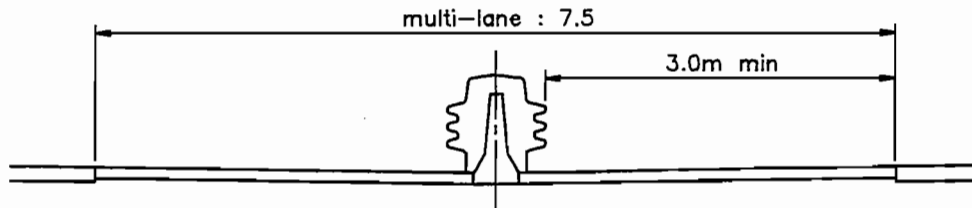

(a) Single Concrete Barrier or I.B.C. Barrier

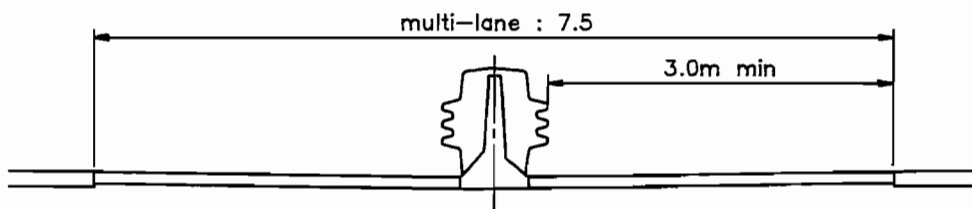

(b) 'Tall Wall' or I.B.C. Barrier

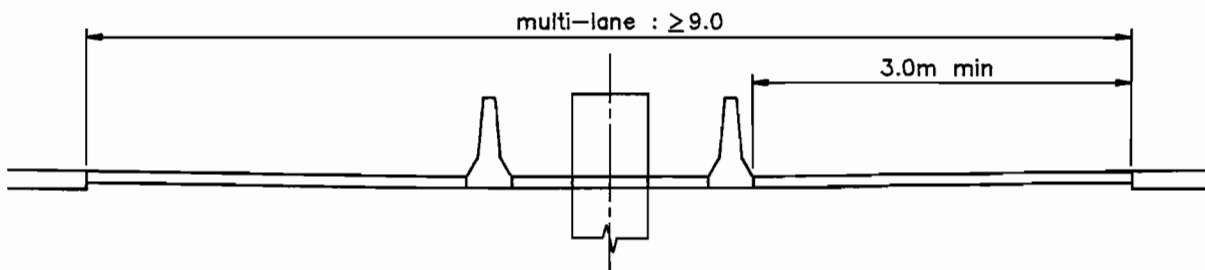

(c) Twin Concrete Barrier

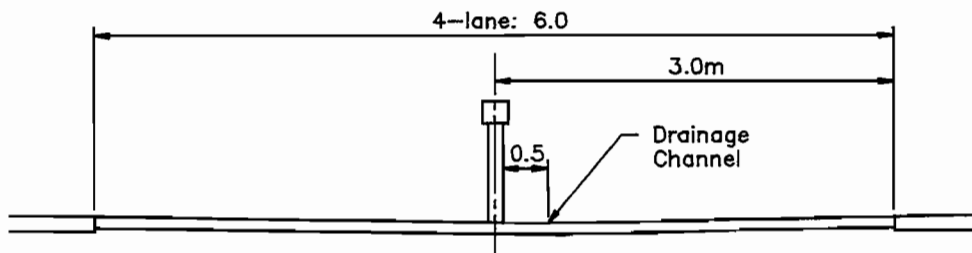

(d) Box Beam Barrier

Figure D6-3
Urban Freeway Flush Median Treatment

On reconstruction projects, at bridge pier locations the median width may be maintained and the shoulder width reduced. The type of barrier protection required is steel beam guide rail with channel. Steel beam barrier systems are desirably offset a minimum of 1 m from the face of the barrier to the pier to allow for barrier deflection. Where limited space precludes offsetting the barrier from the pier, the steel beam guide rail with offset blocks may be anchored directly to the pier. The offset distance 'd' from the bridge pier to the edge of the travelled lane is based on the hazard protection distance warrants for unprotected clearance and is shown in the table with Figure D6-4(b).

Whenever feasible and cost effective, the standard shoulder widths should be maintained.

(ii) Raised Median

Although a raised median design with guide rail is feasible, the performance of the traffic barrier system has proven to be adversely affected by the presence of curb and gutter. For this reason the flush median design is preferred when traffic barriers are required.

Raised medians may be used on urban freeways where double steel beam barrier is applied. A raised median consists of a mountable curb and gutter bordering a level area that is normally surfaced with asphalt or concrete. The standard median width for a 4-lane urban freeway is 6.0 m and 7.5 m for a multi-lane urban freeway.

Double steel beam guide rail with channel shall be used adjacent to mountable or semi-mountable curb with wide gutter in all locations. The face of the steel beam guide rail shall be placed no more than 0.25 m from the face of curb.

The median shoulder width to the edge of curb and gutter shall not be less than 1.5 m for the 4-lane freeway and 2.5 m for the multi-lane freeway. See Figure D6-4(a).

The desirable design is to place double steel beam barriers in a flush median and offset the intersecting slopes of the shoulder 0.5 m from the face of the barrier to create a drainage channel. The drainage channel may be placed on either side of the centreline. See Figure D6-4(a).

Where light poles or sign supports are placed in the median between the two rails, a barrier assembly with additional offset blocks are used to provide sufficient space.

The type of barrier protection required at piers or other median obstacles in raised medians with mountable curb and gutter is steel beam guide rail with channel. The face of the steel beam guide rail shall be placed no more than 0.25 m from the face of curb. The barrier system is desirably offset a minimum of 1.0 m from the face of the barrier to the pier to allow for barrier deflection. Steel beam barrier systems may be anchored directly to the pier where limited space precludes offsetting the barrier. See Figure D6-4(b).

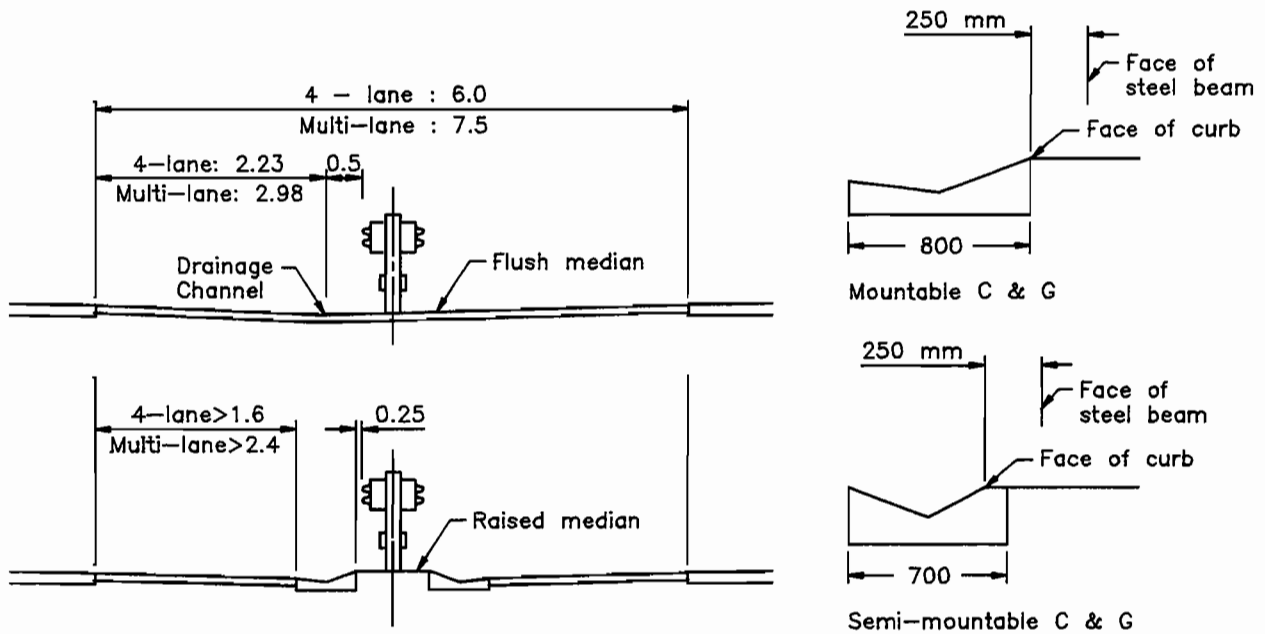

Double Steel Beam Barrier
(a) Without Bridge Pier

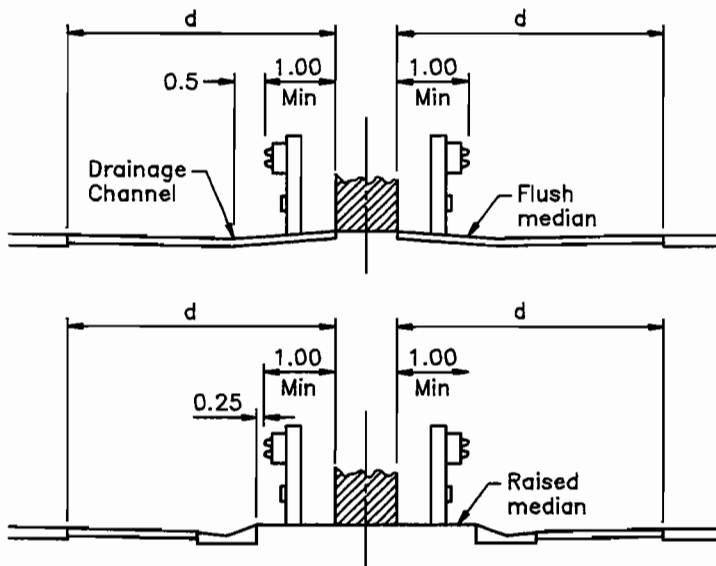

Steel Beam Barrier
(b) With Bridge Pier

Where offset distances are equal to or greater than 'd' barriers are not required

| Design Speed km/h | Offset d m |
|-------------------|------------|
| 120 | 10.0 |
| 110 | 9.0 |
| 100 | 7.0 |

Figure D6-4
Urban Freeway Flush or Raised Median Treatment with Steel Beam Barrier

D.6.2.4 Outer Separations

Outer separations separate express lanes from collector lanes. They usually contain some form of barrier and may accommodate bridge piers and lighting poles.

Viewed in the direction of the traffic, the outer separator consists of the right shoulder of the express lanes and the left shoulder of the collector lanes. Typical outer separations are shown in Figure D6-5.

Where an overhead sign structure for a Freeway Traffic Management System (FTMS) is to be placed in a newly constructed freeway/collector outer separation, this outer separation must be flush, and the FTMS sign structure must be mounted on a footing incorporating the concrete barrier design shape. The minimum width of the outer separation from the centre line of the barrier to the edge of the adjacent express lane is 3.75 m. The minimum width of the outer separation from the centre line of the barrier to the edge of the collector lane is shown below.

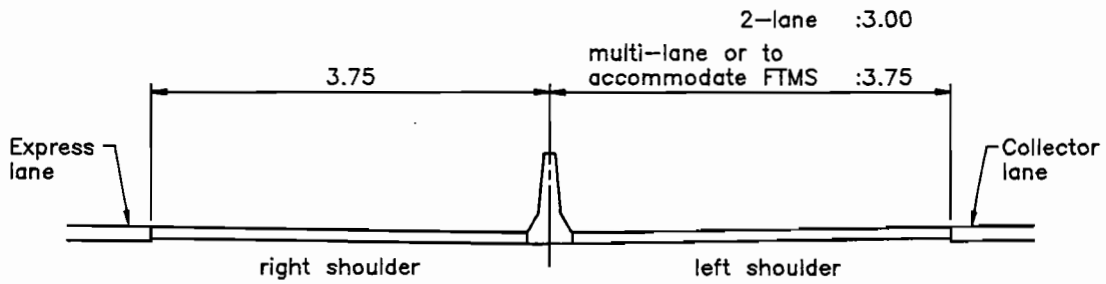

(a) Flush with Concrete Barrier

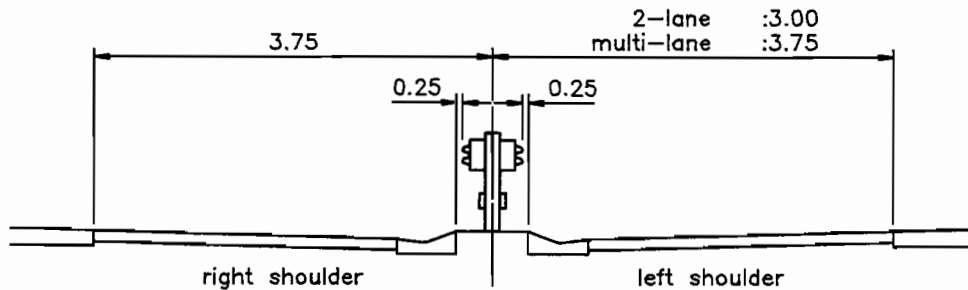

(b) Raised with Steel Beam Guiderail

**Figure D6-5
Outer Separation Treatment**

D.6.3 ARTERIAL HIGHWAYS

Divided arterial highways may have depressed, flush or raised medians. The selection of median type normally depends on whether the highway is urban or rural. Median barrier requirements are based on the Annual Average Daily Traffic (AADT) volumes and the type and width of median.

D.6.3.1 Rural Arterials

Rural arterials have a depressed or a flush median.

(i) Depressed Median

On rural divided arterial roads a depressed median is generally preferred. Design details and dimensions for depressed medians are the same as those for rural freeways presented in Section D.6.2.1.

(ii) Flush Median

Flush medians are usually narrow and used in rural and urban-fringe areas. A flush median without barrier may be appropriate for highways with higher volumes and lower speeds. This median is normally slightly crowned to assist drainage, and is normally paved, often in the same surface material as the adjacent lanes. It is advantageous, however, to surface the median in a contrasting texture and/or colour to alert the errant driver encroaching onto the median. The normal width is 1.0 m. See Figure D6-6(a).

The box beam barrier should be used with the flush median, but its use is restricted; installations are limited to highways where the posted speed is less than 80 km/h. The median width should be at least 3.0 m to allow for deflection of the traffic barrier after being struck without endangering or interrupting the passage of traffic in the opposite direction. The shoulder slopes should intersect 0.5 m from the centreline to create a drainage channel. The drainage channel may be placed on either side of the centreline. See Figure D6-6(b).

The wider flush medians with barriers normally apply to high speed rural arterial roads. In medians with a width less than 7.0 m, it is desirable to construct a concrete barrier, as it performs best at low angle, high speed impacts and requires a minimum of maintenance.

The minimum median treatment with concrete barrier should have a minimum shoulder width of 1.5 m plus the width of concrete barrier. See Figure D6-7(a).

Where provision is required for a bridge pier with concrete barrier, the median width should be 5.0 m plus the width of the pier. See Figure D6-7(b).

The steel beam barrier system may also be used at bridge piers and placed in a flush median with provision of adequate slopes for drainage. Steel beam barrier systems are desirably offset a minimum of 1 m from the face of the barrier to the pier to allow for barrier deflection or may be anchored directly to the pier. See Figure D6-9(a).

The offset distance 'd' from the pier to the edge of travelled lane is based on the hazard protection distance warrants and is shown in the table with Figure D6-9.

Whenever feasible and cost effective, the standard shoulder widths should be maintained.

For barrier selection consult the Traffic Barrier Manual.

(iii) Raised Median

Although a raised median design with guide rail is feasible, the performance of the traffic barrier system has proven to be adversely affected by the presence of curb and gutter. For this reason the flush median design is preferred when traffic barriers are required.

Where a raised median is used on rural arterial highways double steel beam guiderail or box beam barrier is applied. A raised median normally consists of a mountable curb and gutter bordering a level area that is surfaced with asphalt.

Double steel beam guide rail with channel shall be used adjacent to mountable or semi-mountable curb with wide gutter. The face of the steel beam shall be placed no more than 0.250 m from the face of curb. See Figure D6-4(a).

The box beam barrier application requires a mountable curb with wide gutter; however, the use of box beam is restricted to highways where the posted speed is less than 80 km/h. See Figure D6-6(c).

The type of barrier protection required at piers in raised medians with mountable curb and gutter is steel beam guide rail with channel. The barrier system may be anchored directly to the pier but desirably should be offset a minimum of 1.0 m to allow for barrier deflection. The face of the steel beam guide rail shall be placed no more than 0.25 m from the face of curb. See Figure D6-9(b). For detail of curb and gutter refer to Figure D6-4.

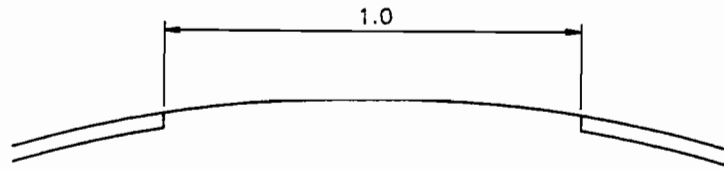

(a) Without Barrier

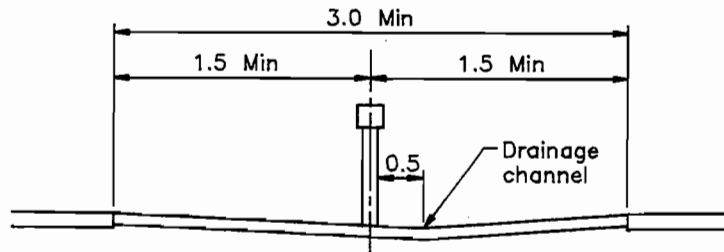

(b) Flush With Box Beam Barrier

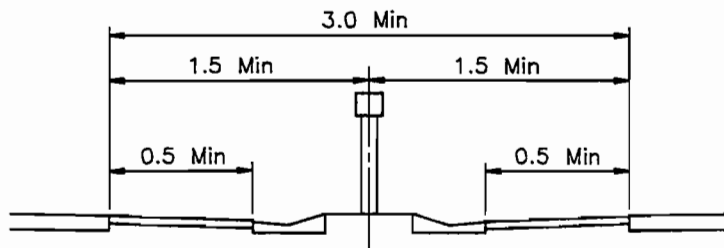

(c) Raised With Box Beam Barrier

Figure D6-6
Rural Arterial Flush or Raised Median Treatment

D.6.3.2 Urban Arterials

Flush or raised medians may be used in urban and urban-fringe conditions.

(i) Flush Median

Design details for the flush median without barrier are given in the preceding subsection.

Where a flush median with barrier is required, it is desirable to construct a concrete type barrier as it performs best for low angle, high speed impacts and requires a minimal amount of maintenance. The minimum median treatment should have a minimum shoulder width of 1.5 m plus the width of the concrete barrier.

With a width of 2.5 m measured from the edge of travelled lane to the centre of the barrier, the median width becomes 5.0 m. See Figure D6-7(a).

Where provision is required for a bridge pier, the median width should be 5.0 m plus the width of the bridge pier. If the bridge pier width is not a multiple of 0.5 m, the shoulder widths should be adjusted to make the median width a standard multiple of 0.5 m. This practice simplifies design and construction.

The steel beam barrier system at bridge piers may also be placed in a flush median with provision of adequate slopes for drainage. See Figure D6-9(a).

Whenever feasible and cost effective, the standard shoulder widths should be maintained.

* When the median width has to be reduced the required width from the edge of travelled lane to the face of the barrier wall is 1.5 m; however, this may be reduced to 0.5 m, subject to approval by the Executive Director, Highway Engineering Division. See Figure D6-7(b).

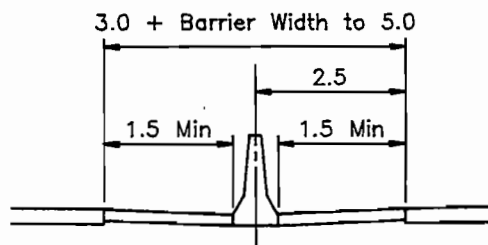

(a) Without Bridge Pier

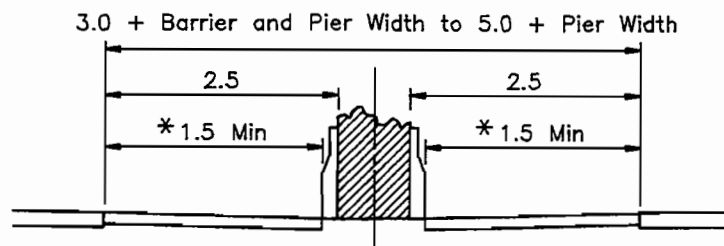

(b) With Bridge Pier

Figure D6-7
Rural and Urban Arterial Flush Median Treatment with Concrete Barrier

(ii) Raised Median

Raised medians are normally applicable to urban areas and may be used on multi-lane urban arterial roads.

Raised medians have application on arterial streets to regulate left-turn movements. They usually include curb and gutter.

On urban arterial roads where a median barrier is not applied, a median width of 2.0 m is sufficient. Barrier curbs with gutter 400 mm wide are normally used, giving a width between faces of curb of 1.2 m. This is sufficient to allow the placement of traffic signs and other features without interference to the normal flow of traffic in adjacent lanes. See Figure D6-8(a).

If provision for a left-turn lane is required, the median width should be increased by the width of the left-turn lane, normally 3.0 m, giving a median width of 5.0 m. See Figure D6-8(b). For detail of left turn lanes see Chapter E, Section E10.1.

Where an arterial passes under a bridge structure, it may be necessary to make provision in the median for a bridge pier with barrier protection. The type of barrier protection required at piers or other median obstacles in raised medians with mountable curb and gutter is steel beam guide rail with channel. Steel beam barrier systems may be bolted directly to the pier but desirably should be offset a minimum of 1.00 m to allow for barrier deflection. The face of the steel beam guide rail shall be placed no more than 0.25 m from the face of curb. See Figure D6-9(b). For detail of curb and gutter refer to Figure D6-4.

Whenever feasible and cost effective, the standard shoulder widths should be maintained.

The offset distance 'd' from the travelled lane to the bridge pier is based on the hazard protection distance warrants for unprotected clearance and is shown in the table with Figure D6-9.

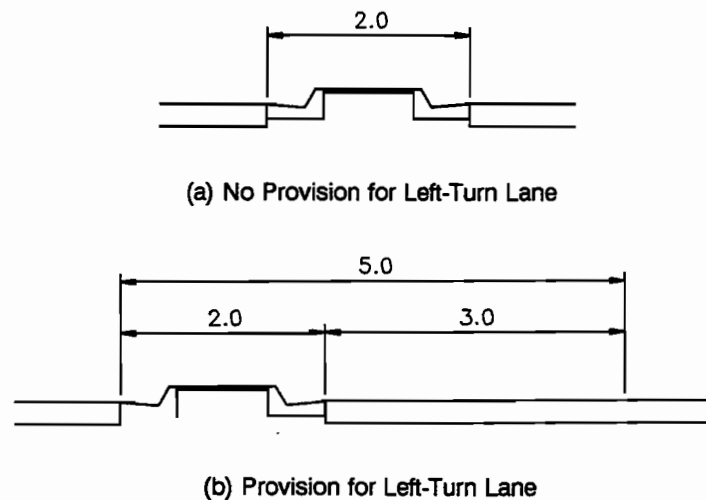

Figure D6-8
Urban Arterial Raised Median Treatment Without Barrier

D.6.4 MEDIAN CROSSOVERS

Median crossovers are unacceptable on highways with median barrier protection.

Median crossovers are acceptable on wide medians where guide rail is not required and are introduced on divided highways to allow police, emergency vehicles and maintenance vehicles to make U-turns to travel in the opposite direction. Their location depends on the distance between adjacent interchanges and the maintenance operation responsibilities. Median crossovers should be located where there is adequate sight distance for through traffic to be aware of accelerating and decelerating traffic using the crossover, as for example, in the vicinity of sag curves.

The design for median crossovers should be in accordance with the current Ontario Provincial Standard adopted by the Ministry.

In the 6m to 20m median width range. It is necessary to widen out the opposite shoulder in order to provide sufficient room for snow plow manoeuvres. All crossovers, regardless of median width, are provided with deceleration tapers. It is important to keep crossovers inconspicuous to avoid their illegal use by motorists. Crossovers for snow plows, including tapers must not be paved.

| Design speed km/h | Offset d m |
|----------------------|------------------|
| 100 | 7.0 |
| 80 | 5.0 |
| 60 | 3.0 |

Where offset distances are equal to or greater than 'd' barriers are not required

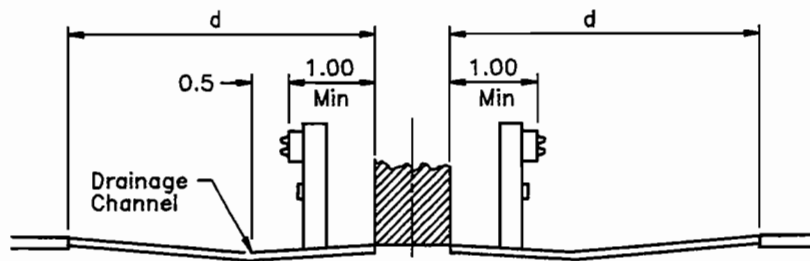

(a) Flush Median

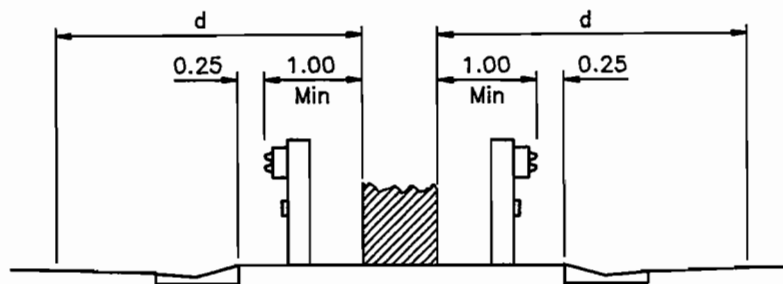

(b) Raised Median

Figure D6-9
Rural and Urban Arterial Flush or Raised Median Treatment with Steel Beam Barrier at Bridge Pier

D.7 STRUCTURES AND CLEARANCES**D.7.1 GENERAL**

The material contained in this section is intended to assist the designer when designing cross sections where bridges, retaining walls or other structures are required. This section gives direction in setting structure dimensions that influence geometric design of horizontal alignment, vertical alignment and cross sections.

In general:

- Bridges should be designed to match the geometric requirements of the roadway.
- Where practicable, the horizontal centreline alignment on bridges should be on tangent or of constant curvature.
- The cross section elements of roads on and under bridges should match those of the approach roadway.
- Sag curves on bridges should be avoided as much as possible.

D.7.2.1 – Deck Width and Traffic Lanes

The number and width of through lanes and auxiliary lanes should be the same on the bridge deck as on the approach roadway. Traffic lane widths should be in accordance with Section D.2.

In general, the minimum acceptable bridge deck roadway width for two way traffic is 8.5 m. Single lane bridges shall be a minimum 5.0 m roadway width except for single lane ramp bridges that shall be a minimum of 4.75 m roadway width.

Provision of narrower or single lane bridges may be permitted on low volume roadways in accordance with the Ministry's Guidelines for the Design of Bridges on Low Volume Roads.

D.7.2.2 – Side Clearances on Bridges

Side clearances on bridge decks, defined as the distance between the edge of the traveled way and the adjacent curb or barrier, should be in accordance with Table D7-1 and Figure D.7-1 for urban and rural structures. Where the side clearances from Table D7-1 are greater than the approach roadway shoulder width/side clearance as specified in D.5, the side clearance should match that of the approach roadway. Provision of wider side clearances may be considered to accommodate future rehabilitation or future widening requirements.

Where the approach roadway has continuous curb or continuous traffic barriers, the side clearances on the bridge deck should match the shoulders on the

approaches but, should not be less than the minimum side clearance per Table D7-1.

On bridges greater than 50 m in length, reduced side clearances may be considered. Before the reductions are applied, the cost savings due to the reduced clearances as well as the implications for future rehabilitation, re-paving or the possible addition of an extra driving lane should be considered.

All clearances should meet requirements for sight distance. Side clearances may be increased to a maximum of 3.00 m where it is necessary to provide for minimum stopping sight distances.

D.7.2.3 – Sidewalks, Bikeways and Curbs

Where required, the widths of sidewalks and bikeways on bridge decks should meet the following requirements:

- The edge of a sidewalk adjacent to the roadway on a bridge should match that of the approach sidewalk.
- Where the approach roadway is not provided with a curb, the sidewalk width should be at least 1.5 m.
- Paved bike lane and bikeway widths should be in accordance with the Ministry's Ontario Bikeways Planning and Design Guidelines. Bikeways should be at least 1.5 m wide for one way traffic.
- The height of curbs should not be less than 150 mm above the adjacent roadway except to match the height of curbs on the approach roadway.
- Curbs should not be used in conjunction with barrier walls except where the curb and the barrier wall are separated by a sidewalk.

D.7.2.4 – Median Widths

The width of a median on a bridge should match that of the approach roadway.

D.7.2.5 – Horizontal Clearances at Underpasses

Where practicable, underpassing roadway cross-sections should match that of the approach roadway.

Horizontal clearances from the edge of the through traveled way to the face of an abutment or pier should meet or exceed the minimum clear zone widths specified in the Ministry's Roadside Safety Manual.

Where auxiliary lanes are present, the horizontal clearances from the edge of the traveled way to the face of an abutment or pier should also meet or exceed the minimum clear zone widths specified in the Ministry's Roadside Safety Manual based on the design speed on the auxiliary lane at the start of the structure.

Additional information on horizontal clearances and

grading at abutments is available in the Ministry's Roadside Safety Manual and Structural Manual.

D.7.2.6 – Vertical Clearances

For vertical clearances refer to section C.4.4.3 of this Manual.

**Table D7-1
Minimum Side Clearances at Bridges**

| | Design Speed (km/h) | Urban Roads | | | Rural Roads | | |
|---------------------------------------|---------------------|-------------|-------------|----------|-------------|-------------|----------|
| | | Left | Right | | Left | Right | |
| | | | No Sidewalk | Sidewalk | | No Sidewalk | Sidewalk |
| FREEWAY 4-LANE DIVIDED | 100 to 120 | 2.5a | 3.0 a | | 2.5a | 3.0 a | |
| FREEWAY MULTI-LANE DIVIDED | 100 to 120 | 2.5 a | 3.0 a | | 2.5 a | 3.0 a | |
| ARTERIAL DIVIDED | 90 to 110 | 2.0 a | 2.5 a | 1.5 | 2.0 | 3.0 a | |
| | 80 | 2.0 a | 2.5 a | 1.5 | 1.5 | 2.5 a | |
| ARTERIAL UNDIVIDED | 90 to 110 | - | 2.0 | 1.5 | - | 3.0 a | 2.5 a |
| | 80 | - | 2.0 | 1.5 | - | 2.5 a | 2.0 b |
| COLLECTOR UNDIVIDED | 90 to 100 | - | 1.25 c | 1.0 | - | 2.5 a | 1.5 c |
| | 70 to 80 | - | 1.25 c | 1.0 | - | 1.5 d | 1.25 |
| | 60 | - | 1.0 | 1.0 | - | 1.5 d | 1.25 |
| LOCAL UNDIVIDED | 60 to 80 | - | 1.0 | 0.5 | - | 1.25 | 0.5 d |

- Notes:
1. If a barrier is to be placed between the sidewalk and roadway, then clearance should be the same as when there are no sidewalks.
 2. All clearance should meet requirements for sight distance.
 3. The width of a median on a bridge should match that of the approach roadway.
 4. L = Length of bridge between centreline of abutment bearings.
 - a - For bridges with L>50 m, consideration can be given to decreasing the clearances to 1.5 m.
 - b - For bridges with L>50 m, consideration can be given to decreasing the clearance by up to 0.5 m.
 - c - For bridges with L>50 m, consideration can be given to decreasing the clearance by 0.25 m.
 - d - For bridges with L>50 m, consideration can be given to increasing the clearance by up to 0.75 m.
 - e – The values of the clearances given above are the minimum values. Consideration may be given to providing more than the minimum if justification is provided.

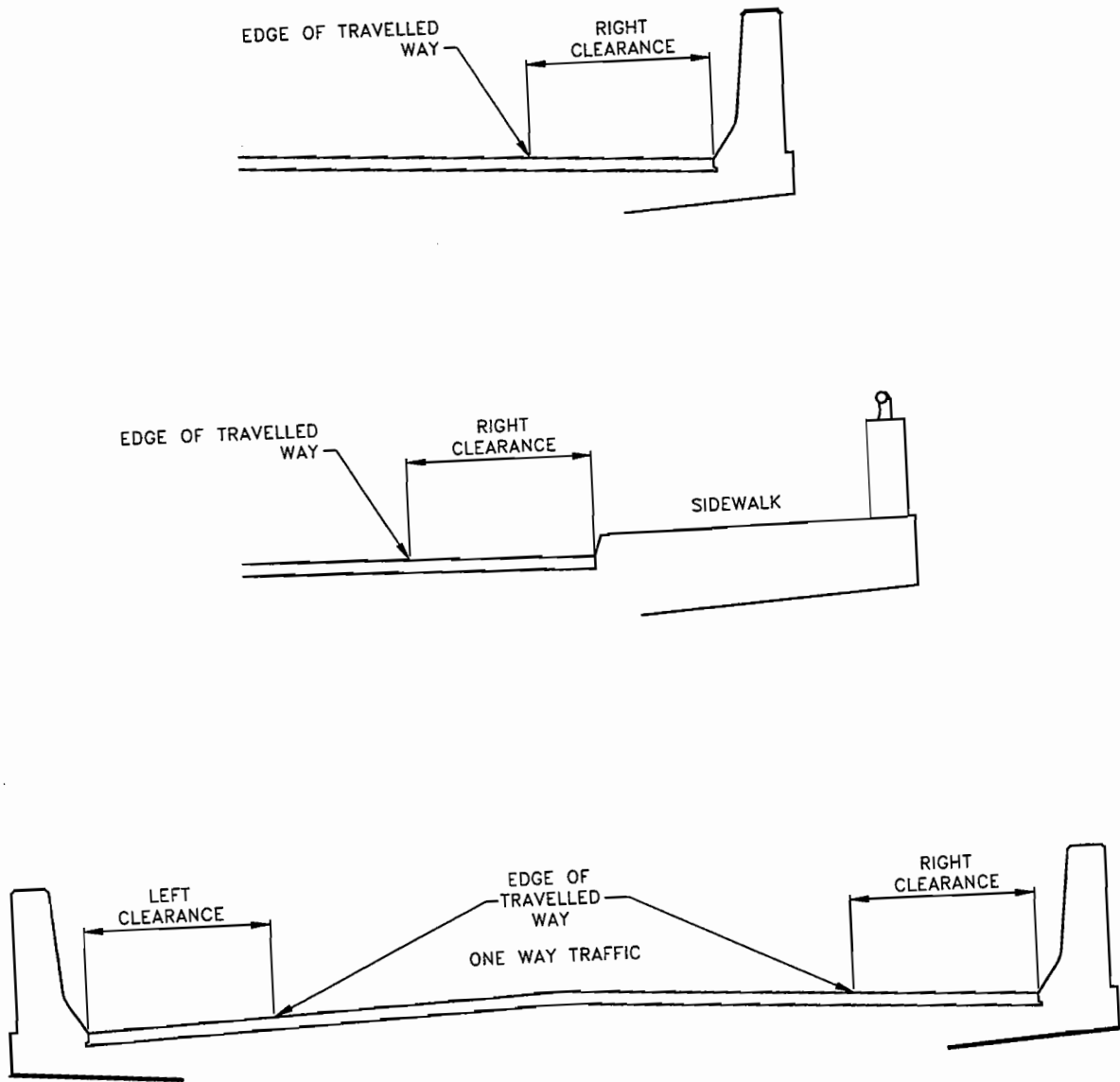

Figure D.7-1
Side Clearance on Bridges

D.8 OFF-ROADWAY ELEMENTS**D.8.1 CURB AND GUTTER**

A curb is a raised element located adjacent to a traffic lane or shoulder. Curbs are normally introduced to control drainage and provide delineation of the pavement edge or pedestrian walkways.

The type and location of curbs can affect driver behaviour and the safety of a highway. Refer to the Roadside Safety Manual. They are extensively used on all types of urban highways, but only to a limited extent on rural highways where drainage is usually controlled by means of drainage channels.

There are two general types of curbs, namely, barrier curbs and mountable curbs, each type having a number of variations in design. Both barrier and mountable curbs may be designed integrally with a gutter to form a single unit. Generally curbs are not to be used in conjunction with traffic barrier systems.

Barrier curbs are relatively steep faced and intended to inhibit or at least to hinder vehicles from leaving the roadway. Typically, the height of the vertical face of the barrier curb is 150 mm. Most barrier curbs are not adequate to prevent a vehicle from leaving the roadway and, where positive containment is required, suitable concrete median barrier or guide rail should be provided. Barrier curbs should not be used adjacent to bridge parapets. A concrete parapet having a profile similar to that of a concrete median barrier is preferred. However, on urban roads where the cross section includes sidewalks on the approaches and the bridge, a barrier curb is carried across the bridge.

Mountable curbs have slightly inclined faces allowing vehicles to cross them readily. Semi-mountable curbs have somewhat steeper faces and are considered to be mountable under emergency conditions. Mountable curbs can be used at median edges. Where a median guide rail is installed, the gutter line of the curbs should be offset minimally from the face of the barrier, to ensure that the traffic barrier will perform properly. This also allows vehicles making emergency stops along the shoulder to do so without suffering body damage. Barrier curbs should not be placed adjacent to high-speed lanes, but may be placed adjacent to shoulders where they serve a definitive purpose.

Gutters may be provided adjacent to a curb to form the principal drainage system for the roadway. Generally the gutter is not considered to be a part of the adjacent traffic lane width, since with any form of curb there is some lateral shy distance accepted by drivers, particularly on their right, which reduces the effective lane width. For this reason, where a curb is provided without a gutter, the curb should be offset from the edge of the through traffic lane, a distance corresponding to a gutter width.

Where curb and gutter is placed at the outside edge of a paved shoulder, the gutter pan is regarded as part of the shoulder width.

Curb and gutter is usually formed with concrete, either precast or cast-in-place. Asphalt curbs are used for local drainage control, normally in rural areas where delineation is not a requirement. Temporary curbs are usually formed of asphalt.

Dimensions for the more commonly used standard ministry curb and gutter cross sections are shown on Figure D8-1. For further information refer to "Ontario Provincial Standards For Road and Municipal Services," Manual, Volume 3; Drawings, Roads-Barriers, Drainage, Sanitary Sewers, Watermains, and Structures.

D.8.2 TRAFFIC BARRIERS

For detailed information regarding traffic barriers refer to the Roadside Safety Manual.

Traffic barriers are used where errant vehicles leaving the roadway would otherwise be subject to undue hazard. Their purpose is to reduce the severity of accidents by restraining and redirecting or decelerating the vehicle without causing hazard to following, adjacent or opposing traffic. Since barriers are hazardous in themselves, emphasis should be placed on minimizing the number of such installations giving consideration to the social, environmental and economic factors as well as to safety.

The primary objective of traffic barriers is to protect the road user from potentially hazardous and not to protect roadway appurtenances from traffic.

A median barrier is used to prevent an errant vehicle from crossing the median of a divided highway and colliding with traffic travelling in the opposite direction. The probability of such a collision is a function of traffic volume, median type and median width. To determine the need for a median barrier, reference should be made to the Roadside Safety Manual.

Since a traffic barrier itself is a hazard, flattening an embankment slope and rounding the shoulder and toe to allow an errant vehicle to safely negotiate the embankment is preferable to installing a barrier. Where flattening the slope is not possible, for example, due to property limitations, a roadside barrier should be provided.

Roadside barriers should be located outside the shoulder so that the full shoulder width remains usable, and should have sufficient fill behind the post to provide lateral support.

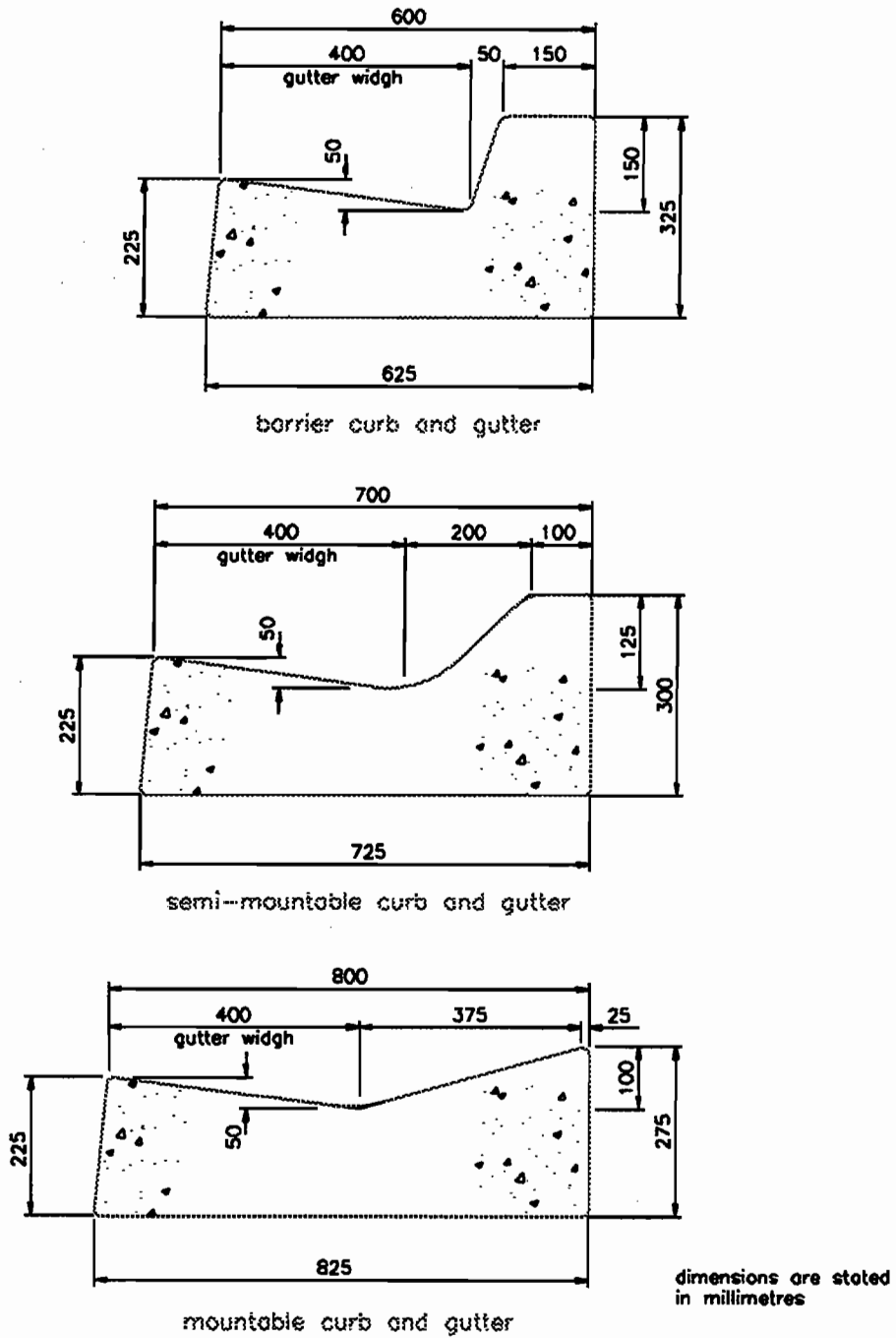

Figure D8-1
Concrete Curb and Gutter Dimensions

Since the end of a barrier facing oncoming traffic is a potential hazard, a series of barrier sections with short gaps between them should be avoided in favour of a single continuous barrier. Judgement is required in each case.

Design details for longitudinal barriers and crash cushions are given in "Ontario Provincial Standards For Road and Municipal Services," Manual, Volume 3; Drawings, Roads-Barriers, Drainage, Sanitary Sewers, Watermains, and Structures."

Traffic barriers are generally denoted as one of three types: flexible, semi-rigid or rigid. The description reflects the degree of barrier deflection that occurs when a barrier is struck.

Flexible

Flexible systems undergo considerable dynamic deflection upon impact and are generally more forgiving than other types, because they impose lower impact forces on the vehicle. The most common forms of flexible barriers used are the cable guide rail and box beam guide rail. These systems are intended to restrain a vehicle rather than redirecting it. They require more lateral clearance from fixed objects due to increased deflection upon impact.

Semi-rigid

In semi-rigid systems the posts near the point of impact are intended to give but not break thereby distributing the impact force by beam action to adjacent posts. Posts outside the impact zone provide the resistance essential to control the deflection of the beam to an acceptable limit and thereby redirect the errant vehicle along the path of the traffic flow.

Rigid

Rigid systems do not deflect upon impact. During a collision energy is dissipated by raising and lowering the vehicle and by deformation of the vehicle. As the angle of impact increases, the barrier becomes less forgiving because of absence of barrier deflection.

D.8.3 CRASH CUSHIONS

Crash cushions are devices placed in front of hazardous objects on the roadside or median to protect the road user, in the event that a vehicle leaves the roadway and strikes the object. Crash cushions reduce the rate of loss of a vehicle's kinetic energy on impact. Crash cushions are typically placed in front of bridge piers and exit signs.

A number of different crash cushions have been designed and evaluated for use. A detailed discussion on their operation is presented in the Roadside Safety Manual.

D.8.4 BOULEVARDS AND SIDEWALKS

The area between the roadway and the sidewalk is referred to as a boulevard. It serves as a safety separation, a location for overhead and underground utility lines and an area for snow storage. The boulevard may also be used to locate traffic signs, fire hydrants and lamp standards. However, it is generally preferred to locate utility poles, lamp standards and other objects potentially hazardous to an errant vehicle as far as possible from the travelled way, as for example, at the back of the sidewalk.

The standard widths for boulevards are:

- . arterial roads 3.0 m
- . collector and local roads 2.0 m

The desirable minimum width for boulevards is 1.5 m.

Where property is limited or where sidewalks have to be wider than usual to accommodate pedestrian traffic, boulevards may be narrower than the standard dimension and in some cases may be omitted entirely. Examples are in downtown areas or in areas fully developed with retail stores and offices.

Boulevards are usually sloped towards the roadway to facilitate drainage. They are normally surfaced with turf, in which case the cross-fall is 0.04 m/m. The area of the boulevard immediately adjacent to the roadway may be finished with a hard surface treatment to avoid deterioration of turf due to winter road clearing operations. This hard surface setback width is normally 0.75 m and is usually only applied to urban conditions where this problem is anticipated.

Materials commonly used for hard surface treatment are:

- . granular
- . asphalt
- . concrete
- . paving stone

In urban areas where the sidewalk is located 3.0 m or less from the traffic lanes and where a reverse shoulder is utilized as a boulevard to suit existing conditions, the shoulder should be fully paved.

Most urban roads other than freeways carry some pedestrian traffic and should be provided with sidewalks unless the pedestrian traffic volume is singularly light. Except for short residential streets, sidewalks should be provided on both sides of the road way unless motor vehicle traffic is expected to be very light.

Normal sidewalk width is 1.5 m and this is generally considered to be a minimum. In high density urban areas it may be necessary to increase the pedestrian capacity by widening sidewalks, using standard widths of 1.75, 2.0, 2.5, or 3.0 m. Where additional width is required and property is restricted, it may be necessary to reduce the boulevard width in favour of a wider sidewalk.

On rural roads sidewalks are usually not required except along sections where there is intensive residential or commercial development. In these cases sidewalks are generally located between the drainage channel and property line. Sidewalks should be provided on both sides of the roadway if motor vehicle traffic is heavy and if the development served is located on both sides of the roadway. Consideration should be given to reclassification of the facility from rural to urban in these cases.

Sidewalks are normally constructed with portland cement or bituminous concrete. The minimum cross-fall for paved surface is 0.02 m/m. Steeper cross-falls may be used but slopes in excess of 0.03 m/m are not desirable except at entrances where 0.05 m/m is acceptable.

Although 1.5 m is a normal width for sidewalks, in residential areas wider sidewalks may be required where the intensity of land use in terms of persons per unit area can cause higher volumes of pedestrian traffic. In determining sidewalk width the following guidelines should be considered:

- Near multiple family dwelling units a width of 1.75 m is adequate unless there is a possibility that the sidewalk may be used for many pedestrians from other sources.
- An extra width of sidewalk should be provided near schools, offices and industrial plants where large pedestrian volumes may occur for short periods.
- Where the adjacent land is used for shopping or entertainment, sidewalks should be at least 2.5 m wide and an additional width might be required.
- In general, pedestrians walk in pairs and in areas of heavy pedestrian traffic, sidewalk widths should permit two pairs to pass without restriction.
- On structures where a barrier wall or guide rail is placed to separate traffic and pedestrians, a 2.0 m sidewalk width is required for maintenance vehicles.

At driveway entrances, barrier or semi-mountable curbs should be replaced by a mountable curb to provide convenient access and egress for vehicle. The length of mountable curb for residential driveways should be equal to the width of driveway plus 1.5 m on either side. For residential parking lots, apartments and institutional developments the length should be the driveway width plus 3.0 m on either side. The slope of the driveway across the boulevard and sidewalk should desirably not exceed 10%. Reference should be made to Ontario Provincial Standard Drawings (OPSD) 300 Series drawing.

When designing an urban highway proper consideration should be given to the requirements of the physically

handicapped. The typical street intersection with a steep-faced curb is one form of obstacle that can be improved to aid the handicapped. Provision of sidewalk ramps of sufficient width for a wheelchair can readily be made at such intersections.

Dimensions of sidewalk ramps are given in Ontario Provincial Standard Drawings (OPSD) 300 Series drawing.

D.8.5 ROADSIDE APPURTENANCES

Attention should be given to safety in the design and location of sign supports adjacent to roadways. Every effort should be made to locate the supports where they are not likely to be struck by out-of-control vehicles. This can be accomplished by locating the support further away from the travelled way. Supports located where they are likely to be struck by an out-of-control vehicle should either be of the breakaway type or should be protected either by a guiderail or some form of impact attenuator.

Illumination poles should be located so as to meet acceptable standards of illumination for the driver while, at the same time, offering minimum potential hazard of equipment supports. Where possible these should be located away from the roadway or be of the breakaway type. Alternatively, some form of protection should be provided for the out-of-control vehicle.

Culvert headwalls and wingwalls that offer additional hazards to vehicles out-of-control on a fill slope should be avoided. Where possible the culvert opening should be flush with the fill slope.

D.8.6 NOISE ATTENUATION

The effect of traffic noise on adjacent existing or planned residential neighbourhoods is an important consideration in planning and designing freeways and limited access arterial roads. Traffic generated noise levels at the source or the receiver are determined by an acoustic study, in which the receiver is considered to be at the outside recreational area adjacent to residential units. The study also predicts the capability of alternative noise control measures to attenuate noise.

Noise control measures are acoustical devices or treatment to any feature of the highway facility intended to lower the impact of highway noise on the adjacent environment. Noise control may be addressed at the noise source, the receiver, and along the noise path. Measures to control noise include corridor location, corridor width, profile location, pavement surface type and acoustical barriers. The selection of the appropriate measure depends on the desired noise level and on the relative cost effectiveness of the alternative noise control measures.

In the design of a new freeway, there may be flexibility to employ any or all of the alternative noise control measures to achieve the most cost-effective design.

CROSS SECTION ELEMENTS

when reconstructing an existing freeway, the practical options for noise control are normally limited to those which can be contained within the existing right-of-way, such as pavement surface type or the introduction of acoustical barriers. Application of noise control measures to an existing freeway, normally referred to as a retrofit, further reduces options to a point where acoustical barriers generally the only practical method.

Acoustical barriers are devices installed between the highway and the residences to reduce sound transmission. Earth berms, walls, or combination berm and wall are the common barrier types. The location, height and material of the barrier is determined by an acoustic analysis.

Berms occupy substantially more right-of-way than barrier walls. Side slopes of berms should be 3:1 or flatter to facilitate maintenance and may be contour graded for aesthetic reasons. Where space in the right-of-way is available, a berm is generally preferred over

OFF-ROADWAY ELEMENTS

a wall for aesthetic reasons and for its longevity. When right-of-way space is limited, for example in urban areas, the barrier wall or combination berm and wall are the most suitable acoustic devices.

Barrier walls are constructed from a variety of materials, the more popular being concrete and steel. Landscaping is normally provided to enhance the appearance of both berms and walls.

Where a noise barrier is installed, provision for access of maintenance vehicle to all areas of the right-of-way is required. Access may be provided by contour grading of berms and by gates or openings in walls.

The interaction of the noise barrier with traffic barriers, structural drainage and illumination facilities must be considered during design.

The mitigating measures described above apply to general cases and solutions to specific problem areas should be found through detailed study.

D.9 GRADING AND DRAINAGE CHANNELS**D.9.1 SLOPES**

Earth cut and fill slopes should be flattened and generally rounded to be consistent with the topography and the type of highway. Effective erosion control maintenance costs and adequate drainage of the subgrade are largely dependent upon proper shaping of the side slopes. Overall economy depends not only on the element of first cost, but also on costs of maintenance of which slope stability is a factor. In addition to these reasons for gentle and rounded slopes on any highway, the proximity of any urban highway to the development and residents of the community call for additional attention to slope treatment and the overall appearance.

On freeways and arterial roads with reasonably wide roadsides, side slopes on embankments and in cuts should be designed to provide a reasonable opportunity for recovery of an out-of-control vehicle. Where the roadside, at the point of departure, is reasonably flat, smooth and clear of fixed objects, many potential accidents can be avoided. Embankments at a slope of 6:1 or flatter can be negotiated by a vehicle with a reasonable chance of recovery and should therefore be provided where feasible. Steeper slopes up to 4:1 may be traversible where the height is moderate and rounding at the bottom is generous. Where the height and slope of roadway embankments are such that an out-of-control vehicle cannot negotiate the slope with minimum hazard, the cross section should be designed for suitable guide rail.

POLICY

MAXIMUM SLOPES ARE DEPENDENT ON THE HEIGHT OF FILL OR DEPTH OF CUT, AND ON THE GRADING MATERIAL.

STANDARD MAXIMUM SLOPES ARE:

- **EARTH GRADING** **2:1**
- **ROCK GRADING:**
 - **FILL SIDE SLOPE** **1.25:1**
 - **CUT-BACK SLOPE** **VERTICAL**

FOR LOWER HEIGHTS OF FILL AND SHALLOWER CUTS, SLOPES SHOULD BE FLATTENED. THE STANDARD MINIMUM SLOPES ARE:

- **EARTH GRADING:**
 - **FILL SIDE SLOPE** **4:1**
 - **CUT-BACK SLOPE** **3:1**
- **ROCK GRADING:**
 - **FILL SIDE SLOPE** **4:1**
 - **CUT-BACK SLOPE** **1:4**

Further flattening of slopes may be considered in view of availability of material and property.

Flat and well-rounded side slopes simplify the establishment of turf and its subsequent maintenance. Usually grass can be readily established on side slopes as steep as 2:1.

In cut sections, side slopes of 6:1 or flatter can usually be negotiated by vehicles leaving the roadway if no obstruction is encountered. Back slopes flatter than 2:1 are desirable in the interest of safety and 3:1 in the interest of maintenance. In rock cut, economy generally requires steep slopes and slopes of 1:4, or vertical faces are commonly used.

D.9.2 SNOW IMPACT

Snow drifts occur where snow particles have been deposited in areas of reduced wind speed. Interruptions to the smooth flow of the wind by features such as changes of grade, fences, landscaping or buildings will cause a disruption of the wind flow and the formation of localized turbulent air zones on the leeward side of the interruption. These zones are usually low velocity regions precipitating snow accumulation. Conversely, less snow is deposited where higher velocities occur. When the low velocity region causing a snow drift has been filled with snow, the snow drift will not continue to increase in size and the depth of the snow draft will not be significantly affected by changes in the wind speed. However, wind speed will affect the rate at which the snow drift will increase.

Roadway cross sections in fill where the prevailing wind is blowing across the roadway will tend to keep reasonably clear of snow. On the other hand, roadway cross sections in cut will tend to precipitate snow drifting on the roadway up to the surrounding ground elevation.

Buildings, dense tree growth and rock faces close to roadways where the prevailing wind is across the road, will tend to generate snow drifting on the leeward side of the obstruction. If these obstructions are close to the road snow drifting may obstruct the roadway itself.

D.9.2.1 Mitigating Measures

Roadways in cut sections that are likely to precipitate snow drifting may be treated in one of two ways to minimize or eliminate the impact. The more desirable treatment is to raise the profile so as to bring the roadway above natural ground elevation. If this is not possible for other reasons, the back slopes of the cut section should be flattened to 7:1 and preferably flatter, so as to eliminate or minimize the area of low wind velocity where snow tends to deposit.

Where snow drifting occurs because of dense tree growth or rock cut, the length of the drift depends on the height of the obstruction. The impact can be minimized by increasing the distance from the obstruction to the roadway and will usually be eliminated by removing the obstruction back to a distance of 15 times the height of the obstruction.

D.9.3 CONTOUR DESIGN

Contour design is usually applied to residual areas of land in interchange areas between ramps, for noise berms and disposal areas. These areas can be graded with varying slopes to give undulating and natural looking appearance. Contour design is carried out in conjunction with drainage design with consideration for safety and, where appropriate in conjunction with landscaping. Residual pockets of land in interchange areas, particularly loop ramps, can be used to dispose of some surplus material and to minimize spoil. Conversely, they may be used to generate additional excavation and to minimize borrow.

D.9.4 DRAINAGE CHANNELS

Drainage channel cross sections must have adequate hydraulic capacity and should be designed to keep water velocities below the scour limits wherever possible. Generally additional capacity should be derived by widening channels. The depth must be a minimum of 0.5 m below the bottom of the subgrade to provide drainage of the pavement structure. The drainage channel therefore should be kept at an adequate depth below the pavement. Channels should have a streamlined cross section for safety, ease of maintenance and to minimize snow drifting. In areas of rock cut where fallen boulders can be expected, it may be desirable to provide a wider drainage channel to collect the boulders. This will reduce the possibility of the boulders resting on the shoulder or roadway, and will facilitate maintenance clean up. The design of drainage channels is dealt with in Chapter C of the Ministry Drainage Manual.

D.10 RIGHT-OF-WAY**D.10.1 CRITERIA**

The right-of-way is that area property established to accommodate a road and its associated features and elements. The right-of-way width required for a facility is determined by establishing dimensions of each element such as roadway width, median sidewalk, boulevard, cut and fill slopes and including such items as provision for landscaping, noise attenuation devices and other environmental features. The dimensions of each of these elements is added together and the next largest right-of-way dimension is selected.

The right-of-way selected applying the above technique may be incompatible with existing property boundaries and may leave some undesirable residual severance, in which case adjustments should be made to the right-of-way and, in turn, this may necessitate some modification of dimensions of the components of the road and associated facilities.

In this way right-of-way becomes a design control and the process of determining cross section elements and right-of-way is iterative.

D.10.2 SELECTION

Standard values for right-of-way widths for urban and rural highways are as follows: 20, 26, 30, 35, 40, 45, 50, 55, 60, 70, 80, 90, and 100 m. The right-of-way for new or improved facilities should be selected from one of the above standard values. On reconstruction projects property acquisition is normally limited to that required for the improvement.

Rural local roads are generally at-grade and would require 20-m right-of-way unless significant cut and fill slopes were required. Rural collector roads would generally require 20-m or 26-m right-of-way and rural arterial roads would require a right-of-way in the range of 26 m to 40 m, plus provision for cut and fill slopes, and median width in the case of divided highways.

APPENDIX A

SUMMARY OF GEOMETRIC DESIGN STANDARDS

This section summarizes the more significant standard dimensions for cross section elements shown in this Chapter together with those for horizontal alignment shown in Chapter C - Alignment.

Standards are given for:

- Rural King's Highways
- Secondary Highways
- Undivided Urban Roads

Table DA-1

GEOMETRIC DESIGN STANDARDS FOR RURAL KING'S HIGHWAYS

| DESIGN YEAR TRAFFIC VOLUME | | DESIGN SPEED | MINIMUM CURVES (m) | | | MINIMUM STOPPING SIGHT DIST. | MAX. GRADE | WIDTH (m) | |
|-------------------------------|------------------------|-----------------|--------------------|----------|-------|---------------------------------------|---------------|--------------|----------|
| | | | HORIZ. | VERTICAL | | | | | |
| AADT | DHV | km/h | Radius | K-Crest | K-Sag | m | % | Lane | Shoulder |
| Greater than 4000 | Greater than 600 | 120 | 650 | 120 | 60 | 245 | 6-7 | 3.75 | 3.00 |
| | | 110 | 525 | 90 | 50 | 215 | 6-7 | 3.75 | 2.50A |
| | | 100 | 420 | 70 | 45 | 185 | 6-8 | 3.75 | 2.50A |
| | | 90 | 340 | 50 | 40 | 160 | 6-8 | 3.50A | 2.50 |
| | | 80 | 250 | 35 | 30 | 135 | 6-8 | 3.50 | 2.50 |
| 4000 to 3000 | 600 to 450 | 110 | 525 | 90 | 50 | 215 | 6-7 | 3.75 | 2.50A |
| | | 100 | 420 | 70 | 45 | 185 | 6-8 | 3.50A | 2.50 |
| | | 90 | 340 | 50 | 40 | 160 | 6-8 | 3.50A | 2.50 |
| | | 80 | 250 | 35 | 30 | 135 | 6-8 | 3.50 | 2.50 |
| | | 70 | 190 | 25 | 25 | 110 | 6-12 | 3.25 | 2.00 |
| 3000 to 2000 | 450 to 300 | 110 | 525 | 90 | 50 | 215 | 6-7 | 3.75 | 2.50 |
| | | 100 | 420 | 70 | 45 | 185 | 6-8 | 3.50B | 2.50 |
| | | 90 | 340 | 50 | 40 | 160 | 6-8 | 3.50 | 2.00B |
| | | 80 | 250 | 35 | 30 | 135 | 6-8 | 3.25 | 2.00 |
| | | 70 | 190 | 25 | 25 | 110 | 6-12 | 3.25 | 2.00 |
| 2000 to 1000 | 300 to 150 | 110 | 525 | 90 | 50 | 215 | 6-7 | 3.50C | 2.50 |
| | | 100 | 420 | 70 | 45 | 185 | 6-8 | 3.50 | 2.00C |
| | | 90 | 340 | 50 | 40 | 160 | 6-8 | 3.25 | 2.00 |
| | | 80 | 250 | 35 | 30 | 135 | 6-8 | 3.25 | 2.00 |
| | | 70 | 190 | 25 | 25 | 110 | 6-12 | 3.00 | 1.00 |
| | | 60 | 130 | 15 | 18 | 85 | 6-12 | 3.00 | 1.00 |
| 1000 to 400 | 150 to 60 | 100 | 420 | 70 | 45 | 185 | 6-8 | 3.50 | 1.00 |
| | | 90 | 340 | 50 | 40 | 160 | 6-8 | 3.25 | 1.00 |
| | | 80 | 250 | 35 | 30 | 135 | 6-8 | 3.25 | 1.00 |
| | | 70 | 190 | 25 | 25 | 110 | 6-12 | 3.00 | 1.00 |
| | | 60 | 130 | 15 | 18 | 85 | 6-12 | 3.00 | 1.00 |
| Less than 400 | Less than 60 | 80 | 250 | 35 | 30 | 135 | 8 | 3.25E | 1.00D |
| | | 70 | 190 | 25 | 25 | 110 | 12 | 3.00 | 1.00D |
| | | 60 | 130 | 15 | 18 | 85 | 12 | 3.00 | 1.00D |
| | | 50 | 90 | 8 | 12 | 65 | 12 | 2.75 | 1.00D |

- A - if number of trucks \geq 10%
- B - if number of trucks \geq 15% increased by one increment
- C - if number of trucks \geq 25%
- D - 0.5 m shoulders will be permitted where there is no foreseeable possibility of the road being paved within a 20-year period.
A minimum of 1.0 m shoulder must be used where guide rail is installed.
- E - A 3.0 m lane width may be acceptable where the type, size and volume of trucks are not significant.

Notes:

- Design Year should reflect the anticipated life span of the proposed improvement. Design Year is normally 10 years beyond the Program Year for resurfacing and reconstruction projects, and 20 years beyond for new construction projects.
- Use DHV if available for selection of design standards.
- Minimum Horizontal Curve Radius based on maximum superelevation of 0.06 m/m.
- Minimum desirable shoulder width for:
 - pavement support - 1.0 m gravel shoulder
 - 0.5 m paved shoulder
 - disabled vehicle - 2.0 m shoulder
- Standard lane width increment - 0.25 m.
- Standard shoulder width increment - 0.5 m.
- Shoulder rounding: 1.0 m for design speed greater than 100 km/h
 0.5 m for design speed less than or equal to 100 km/h.

Table DA-2

GEOMETRIC DESIGN STANDARDS FOR SECONDARY HIGHWAYS

| DESIGN YEAR TRAFFIC VOLUME | | DESIGN SPEED | MINIMUM CURVES (m) | | | MINIMUM STOPPING SIGHT DIST. | MAX. GRADE | WIDTH (m) | |
|----------------------------|------------------|--------------|--------------------|----------|-------|------------------------------|------------|-----------|----------|
| | | | HORIZ. | VERTICAL | | | | | |
| AA DT | DHV | km/h | Radius | K-Crest | K-Sag | m | % | Lane | Shoulder |
| Greater than 1000 | Greater than 150 | 100 | 420 | 70 | 45 | 185 | 6-8 | 3.50 | 2.00 |
| | | 90 | 340 | 50 | 40 | 160 | 6-8 | 3.25 | 2.00 |
| | | 80 | 250 | 35 | 30 | 135 | 6-8 | 3.25 | 2.00 |
| | | 70 | 190 | 25 | 25 | 110 | 6-12 | 3.00 | 1.00 |
| | | 60 | 130 | 15 | 18 | 85 | 6-12 | 3.00 | 1.00 |
| 1000 to 400 | 150 to 60 | 80 | 250 | 35 | 30 | 135 | 6-8 | 3.25* | 1.00 |
| | | 70 | 190 | 25 | 25 | 110 | 6-12 | 3.00 | 1.00 |
| | | 60 | 130 | 15 | 18 | 85 | 6-12 | 3.00 | 1.00 |
| Less than 400 | Less than 60 | 80 | 250 | 35 | 30 | 135 | 8 | 3.25* | 1.00** |
| | | 70 | 190 | 25 | 25 | 110 | 12 | 3.00 | 1.00** |
| | | 60 | 130 | 15 | 18 | 85 | 12 | 3.00 | 1.00** |
| | | 50 | 90 | 8 | 12 | 65 | 12 | 2.75 | 1.00** |

Lane width may be increased by 0.25 m to a maximum of 3.5 m if warranted by type, size and volume of truck traffic.

- * A 3.0 m lane width may be acceptable where the type, size and volume of trucks are not significant.
- ** 0.5 m shoulders will be permitted where there is no foreseeable possibility of the road being paved within a 20-year period. A minimum of 1.0 m shoulder must be used where guide rail is installed.

Notes:

- Design Year should reflect the anticipated life span of the proposed improvement. Design Year is normally 10 years beyond the Program Year for resurfacing and reconstruction projects, and 20 years beyond for new construction projects.
- Use DHV if available for selection of design standards.
- Minimum Horizontal Curve Radius based on maximum superelevation of 0.06 m/m.
- Minimum Vertical Curve Standards based on stopping sight distance.
- Lower value in maximum grade range is desirable. Higher value is acceptable.
- Minimum desirable shoulder width for:
 - pavement support - 1.0 m gravel shoulder
 - 0.5 m paved shoulder
 - disabled vehicle - 2.0 m shoulder
- Desirable Shoulder Rounding - 0.5 m.

Table DA-3

GEOMETRIC DESIGN STANDARDS FOR UNDIVIDED URBAN ROADS

| DESIGN YEAR TRAFFIC VOLUME | | DESIGN SPEED | NO. OF LANES | LANE WIDTH | PARKING LANE WIDTH | MAXIMUM GRADE |
|----------------------------|------------------|--------------|--------------|------------|--------------------|---------------|
| AADT | DHV | km/h | | m | m | % |
| Greater than 6000 | Greater than 600 | 80 | 4 | 3.5 - 3.75 | | 6 - 8 |
| | | 60 - 70 | 4 | 3.5 | | 6 - 12 |
| 6000 to 3000 | 600 to 300 | 60 - 70 | 4* | 3.5 | | 6 - 12 |
| | | 80 | 2 | 3.5 - 3.75 | 2.5 - 3.0 | 6 - 8 |
| | | 60 - 70 | 2 | 3.5 | 2.5 - 3.0 | 6 - 12 |
| 3000 to 2000 | 300 to 200 | 80 | 2 | 3.5 | 2.5 - 3.0 | 6 - 8 |
| | | 60 - 70 | 2 | 3.25 | 2.5 - 3.0 | 6 - 12 |
| | | 50 | 2 | 3.0 | 2.5 - 3.0 | 6 - 12 |
| 2000 to 1000 | 200 to 100 | 60 - 70 | 2 | 3.25 | 2.5 - 3.0 | 6 - 12 |
| | | 50 | 2 | 3.0 | 2.5 - 3.0 | 8 - 12 |
| Less than 1000 | Less than 100 | 40 - 50 | 2 | 2.75 - 3.0 | 2.5 - 3.0 | 8 - 12 |

* Four lanes may be appropriate toward the upper limits of this traffic range when there is a measurable capacity deficiency with only two lanes.

Notes:

- Design Year should reflect the anticipated life span of the proposed improvement. Design Year is normally 10 years beyond the Program Year for resurfacing and reconstruction projects, and 20 years beyond for new construction projects.
- Use DHV if available for selection of design standards.
- Lane widths and parking lane widths do not include width of gutter.